



# Hot Water for your Home



**Residential  
Water Heating Range**

**Current Edition 6.2  
January 2025**

# WHY CHOOSE RHEEM

Since 1958, Rheem has been a trusted name in New Zealand, leading the way in water heating innovation. Starting with gas-fired water heaters, and evolving to cutting-edge heat pump water heating technologies, Rheem continues to set industry standards. As part of a global family of brands, our aim is to make the most energy efficient products that save you money whilst lowering our impact on the environment.

# THE BRAND YOU CAN TRUST

Hot water is one of life's true necessities, and at Rheem, we take pride in producing reliable, high-quality products backed by exceptional award-winning service. With decades of experience and a reputation for innovation, Rheem is a name you can trust for all your water heating needs. Our commitment to excellence ensures you have access to the best water heating solutions available. For more information, please visit our website at [www.rheem.co.nz](http://www.rheem.co.nz) or call our Customer Service specialists at 0800 657 336.

# DESIGNING FOR ZERO WASTE

Since 1958, Rheem has led the way in water heating innovation in New Zealand. We're dedicated to Aotearoa – its land, its people, and its future. Our commitment to zero waste and environmental sustainability drives us to continually improve our products and processes. With intelligent products, responsible practices, and inspired people, we are focused on achieving our bold vision for a sustainable future.



Rheem is a member of the Sustainable Energy Association of New Zealand, SEANZ.



# MAINS PRESSURE CYLINDERS

Vitreous enamel (VE), is a long established and trusted finish for metal. It is entirely inorganic and the enamel coating is fused (i.e. not coated) to the metal substrate of the water heater at temperatures in excess of 900°C. This provides a durable, impervious, hygienic and hard finish to prevent rusting and corrosion.

Rheem Vitreous Enamel water heaters provide the best corrosion resistance to a wide range of water conditions including varying pH levels, high chlorides, hard water and MIC (Microbiological Induced Corrosion) as found in parts of the country and areas with untreated bore water.



## Optima Vitreous Enamel (VE)

Mains Pressure

Colour-bond jacket

Twin element models (300L and 400L)

All VE water heaters are fitted with a sacrificial magnesium anode to provide additional corrosion protection to the cylinder in adverse water conditions

2-7 people	180-400L	Indoor/Outdoor installation
------------	----------	-----------------------------

Refer to page 13 for specifications

### \*Night rates

You may be able to switch to a night rate electricity tariff which could halve your hot water bill. It's not available in all areas of the country though - check with your electricity supplier first.



## Vitreous Enamel (VE)

Mains Pressure

Large range of sizes

Twin & dual element models

Can deliver up to 40 litres of hot water per minute

Suitable for a wide range of water conditions

All VE water heaters are fitted with a sacrificial magnesium anode to provide additional corrosion protection to the cylinder in adverse water conditions

1-7 people	25-300L	Indoor installation
------------	---------	---------------------

Refer to page 13 for specifications

# MAINS PRESSURE STAINLESS STEEL

As older low pressure systems need replacing, the trend is to replace these with mains pressure.

With up to 40 litres per minute flow rate you can have multiple showers and taps running while maintaining a stable shower temperature.

Our stainless steel mains pressure water heaters are generally heated with electricity and most models are also heat pump and solar compatible.

Available in various sizes from 135 to 300 litres.

## Stainless Steel

Heat pump and solar compatible (excludes 135L model)

Suitable for a wide range of water conditions

Colour-bond jacket

Incoloy element (top element kit-set available as spare part for 180, 250 and 300L models)

TPR valve setting: 135 & 180L = 1000 kPa, 250 & 300L = 850kPa

1-7 people	135-300L	Indoor/outdoor installation
------------	----------	-----------------------------

Refer to page 14 for specifications

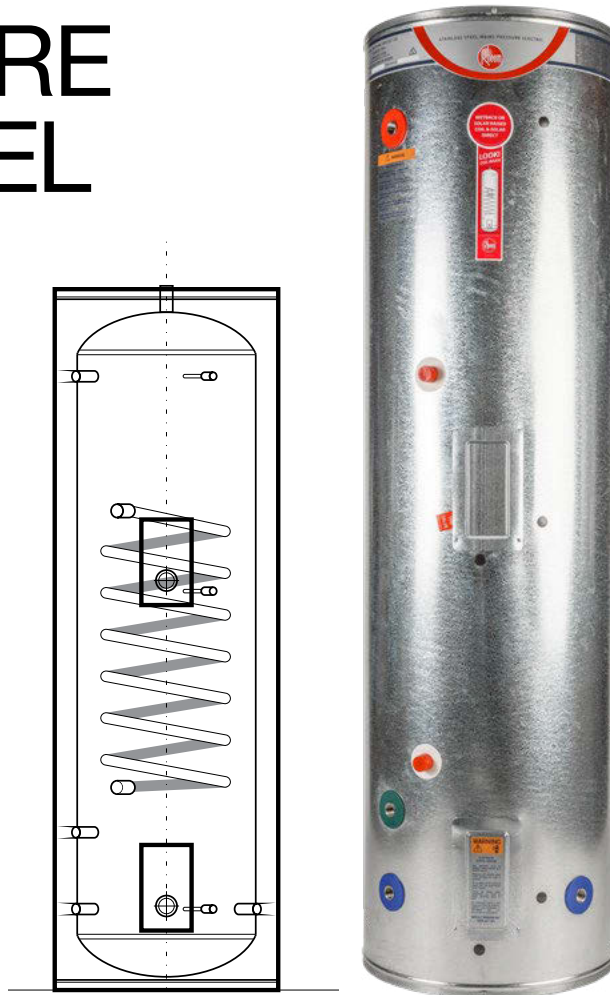

The tried and tested coil heat exchanger system provides an opportunity to future proof your hot water supply. It can be connected to either solar, wetback or heat pump or a combination of these sources.

Each unit comes with a lower element installed and an upper element can also be added to act as a back-up or booster.

## Stainless Steel Coil

Mains Pressure

Designed and engineered in New Zealand

Single or dual coil options

Versatile and economical

Heat pump, solar or wetback compatible

2-7 people	250 & 300L	Indoor installation
------------	------------	---------------------

Refer to page 14 for specifications

# LOW PRESSURE

Low Pressure cylinders were the only option available in New Zealand until the 70's. There are three ways you can identify these water heaters; a copper pipe which protrudes through the roof venting to the atmosphere, a large pressure reducing valve on the inlet or a header tank in the ceiling space.

They are still popular today and a good choice for like-for-like replacement. Rheem also offer low pressure vitreous enamel models which can operate at higher pressure (120kPa) and are ideal for pumped systems and areas where water quality is poor.



## Low Pressure Copper

Choice of 3 inlets (90-180L only)

Tall, medium, short size options

Wetback models available from 135L

1-6 people

15-300L

Indoor installation

Refer to page 15 for specifications



## Low Pressure Vitreous Enamel (VE)

Proven & tested Vitreous Enamel Technology

Built to suit a wide range of water conditions

Designed to operate as Low Pressure Heavy Head - 120 kPa

Triple inlet as standard

1-7 people

90-270L

Indoor installation

Refer to page 15 for specifications



# HEAT PUMP

Rheem Heat Pump water heaters are an energy-efficient, affordable way to heat water. Heat Pumps use the heat from the surrounding air to heat your water and help reduce your water heating energy consumption compared to an electric water heater. They work all year round, day or night, in sunshine or rain and even on cooler days, as there is always heat in the atmosphere which can be used. Heat pumps deliver similar benefits to solar without the need to install roof-mounted solar panels. Environmentally friendly heat pumps are the future of water heating and are available now.



## AMBIPOWER® MDC-180 Heat Pump

Advanced wrap-around microchannel heating technology for uniform and faster water heating

High recovery rate for fast heating and 2.4kW boost element

Suitable for cold climates (-7°C to +43°C)

Suitable for harsh water conditions

LED display for optimum visibility

Timer function

Adjustable temperature function

Up to 4 people	178L
----------------	------

Outdoor Installation

**Refer to page 18 for specifications**



## AMBIPOWER® 280e Heat Pump

Uses R290 refrigerant with ULTRA LOW GWP of <3

Suitable for cold climates (-6°C to +43°C)

Suitable for harsh water conditions

2.4kW boost element

LED touchscreen controller provides optimum visibility

Timer function

Non-adjustable temperature

Up to 6 people	280L
----------------	------

Outdoor Installation

**Refer to page 18 for specifications**



## Ambiheat® HDc-270 Heat Pump

Advanced wrap around microchannel heating technology for uniform and faster water heating

Suitable for cold climates (-5°C to 43°C)

Suitable for harsh water conditions

High recovery rate for fast heating and 2.4kW back-up element for emergency heating

Leading technology with user-friendly touch screen LED display

Variable temp control

Up to 6 people      270L

Outdoor Installation

**Refer to page 18 for specifications**



## ECLIPSE® Electric Continuous Flow

The Rheem 3-phase Continuous Flow Electric Water heater unit delivers hot water with precision, and fast. As well as the increased convenience and greater energy savings, you can ensure you get your requested hot water temperature every time.

Designed for residential apartments and commercial buildings with fast-temperature delivery.

Quick access to pre-set safe bath temperatures with a touchscreen display. Desired temperatures for memory modes can be adjusted via display options.

Both 18kW and 27kW models are available in 50°C and 60°C maximum output temperatures to suit site requirements. These models can be installed without any further tempering in accordance with AS/NZS 3500.4. Includes trade adjustability for desired temperature at the tap in accordance with NZBC G12.



Low activation flow rate to suit low-flow tapware and high ambient temperatures

Flexible installation options with inlet and outlet fittings and electrical connection concealed through the wall or from the bottom of the water heater

Display of water consumption and flow rate on touch screen

Automatic sleep mode for energy savings

Quick access to pre-set child-safe or bath temperatures with touch screen display.

**Refer to page 19 for specifications**

# GAS CONTINUOUS FLOW

Rheem are world leaders when it comes to manufacturing continuous flow gas water heaters. World class Japanese built gas water heaters are sold to multiple countries on a global scale including the USA and Rheem is proud to offer these in New Zealand.

Working differently from traditional storage water heaters, continuous flow water heaters only heat water on demand rather than heating and storing water until needed. Appliances can be conveniently mounted to, or recessed into, your exterior wall, taking up less space. They are ideal for homes with high peak loads or when hot water is required occasionally such as at a holiday home.

Either connected to Natural Gas or to ULPG storage bottles, the water temperature is pre-set on the appliance or is adjustable with optional remote temperature controllers installed indoors.

In homes where there is a high demand for water, or in colder areas where ambient water temperature is low, two appliances can be linked together using the Rheem EZ Link® system to supply twice the flow.



## Outdoor - Rheem 16

1–1.5 Bathrooms | 1–3 people

An ideal solution for compact home sites, baches, cribs or apartments.

## Outdoor - Rheem 20

1.5–2 Bathrooms | 2–4 people

Medium capacity model ideal for small to medium sized homes and apartments.

## Outdoor - Rheem 26

2–3 Bathrooms | 4–6 people

A popular model in more temperate areas, with the capacity to suit most homes.

## Outdoor - Rheem 27

2.5–3 Bathrooms | 4–6 people

Our most popular capacity, ideal for larger families with limited space and high demands for hot water.

## Indoor - Rheem 27

2.5–3 Bathrooms | 4–6 people

The only Rheem indoor continuous flow model (must be flued to the outside of the building).

## Accessories

- Flue Kit (for indoor installation)
- Recess Box
- Pipe Cover
- EZ Link® Kit

## Gas Continuous Flow

Flamesafe overheat protection system

6 star energy rating

Digital display for easy fault diagnosis and service

Frost protection

Can link two units for increased supply with EZ Link®

Indoor and outdoor models

Control your water temperature with remote controllers

16L–27L per minute

Natural Gas or ULPG

Refer to page 17 for specifications

# GAS STORAGE

Rheem Stellar® can only be described as the “King” of gas water heaters. New Zealand’s most efficient domestic gas storage water heater is designed for a long life outdoor installation.

The balanced super-flue design pulls the gas heated hot air through the unit twice to maximise efficiency. The exhaust temperature exits at a very safe temperature through a very modern stylish exterior flue that looks the part.

The Stellar® delivers hot water at up to 40 litres per minute, ideal for the modern home with high delivery tapware, massage showers and multiple bathrooms. If your home uses reticulated natural gas for heating and cooking, then it makes sense to heat your water with gas.

Mains Pressure gas storage water heaters deliver hot water instantly by keeping a generous quantity stored hot and ready for your use.



## Stellar® Outdoor Gas Storage

No electricity required

Suitable for all water pressures

Most efficient domestic gas storage water heater

Advanced SuperFlue Technology

Natural Gas only

2-6 people	130 & 160L	Outdoor installation
------------	------------	----------------------

Refer to page 16 for specifications

## Indoor Gas Storage

Mains Pressure

No electricity required

Advanced SuperFlue Technology

Natural Gas only

2-6 people	130 & 160L	Indoor installation
------------	------------	---------------------

Refer to page 16 for specifications

# LAZER® BOILING WATER

## Energy efficient

The Lazer® Office and Commercial appliances feature a seven-day programmable timer and a selectable sleep mode which will turn the unit off if it has not been used for a set period of time. The Lazer® Eco features an 'Eco Mode' which turns the unit off 2 hours after use to reduce unnecessary power consumption.

## Peak performance

Packed with performance features, the actual unit size of the new Rheem Lazer® range is exceptionally compact and with only two moving parts - one being the tap - they are more reliable than ever.

## Installation

The mounting bracket is easily mounted on the wall above your sink or benchtop. This allows for quick installation and easy removal when service or maintenance is required. Mounting brackets come standard with the Lazer® Office range and is an optional extra for the Lazer®Eco 3L and 5L units.

## Filter

All Rheem Lazer® models can be connected with a remote filter kit for clean, crisp water delivery. Both the Lazer® Office and Lazer® Commercial appliances will alert via the display when the filter needs replacing.



**Lazer® Eco**  
Energy Saving

## Lazer® Eco



Available in 3, 5 and 7.5L capacities

Eco Mode button control

Indicator light changes colour, so you know at a glance when it's heating or in Eco Mode

Optional safety tap available

Easy to clean white powder coat finish

Max 185 cups\* per hour

3L-7.5L

Wall mounted

**Refer to page 21 for specifications**

\*Cup size 170ml

# Lazer® Office



Available in 3 and 5 litre capacities

Delivers up to a maximum of 170 cups\* of boiling water per/hr

Available in powder coat white or brushed stainless steel

Integrated tap

Easy clean

Mounting bracket supplied

Max 170 cups* per hour	3L & 5L	Wall mounted
------------------------	---------	--------------

**Refer to page 21 for specifications**

\*Cup size 170ml



**Lazer® Office**  
Stylish & Efficient



**Lazer® Commercial**  
High Capacity

# Lazer® Commercial



Delivers a maximum of 512 cups\* per hour (depending on model)

Fast flow tap

Available in powder coat white or brushed stainless steel

Easy clean

Large range of capacities available

Safety Tap (optional)

Max 512 cups* per hour	7.5-40L	Wall mounted
------------------------	---------	--------------

**Refer to page 21 for specifications**

\*Cup size 170ml

# Zip® – a Kiwi classic

Rheem New Zealand manufactures manually filled and switched Zip® overbench products. These units have reliably provided boiling water across New Zealand for generations, making them an economical choice for church halls, clubs, factories, and places needing boiling water infrequently.

Sight glass to view water level

Manual fill and boil operation

Optional safety tap available

An economical option when hot water is required infrequently

4.5L – 34L	Wall mounted
------------	--------------

**Refer to page 21 for specifications**



# BOILING WATER

Our boiling, chilled, and filtered water systems cater to homes, offices, and factories. With over 40 years of experience, we offer reliable and sophisticated solutions known for excellence and great customer service. Our functional and cost-effective products reflect our commitment to economic and environmental responsibility.

## On-Tap Plus

### All your water supplied from under the bench

The combination of On-Tap with its matching mixer provides a superior all-in-one underbench solution for your new or existing work or kitchen space.

With the convenience of drawing all your boiling, chilled and mixed water from the compact underbench appliances, this range is easy to install and avoids the costs associated with connecting to your existing hot water system.

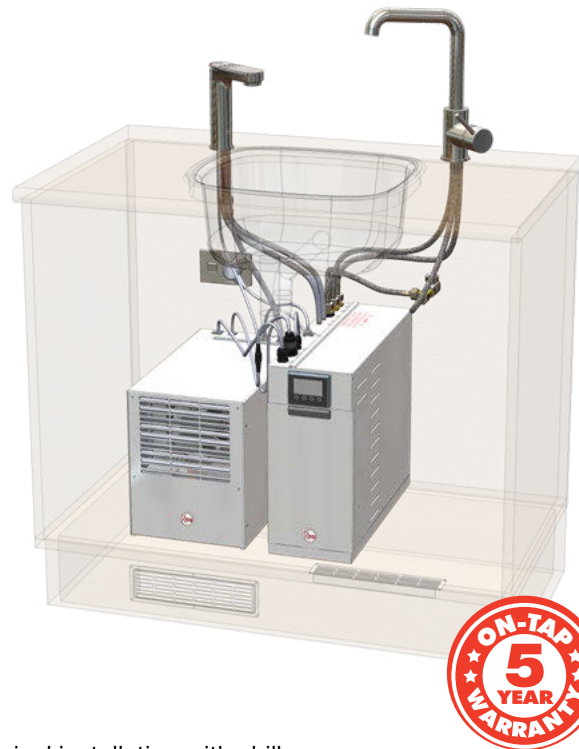

On-Tap Plus with its matching mixer tap is your all-in-one underbench water solution.

Typical installation with chiller (sold separately)

## On-Tap



Available in two stylish tap designs

Sink-free options available

24/7 timer, sleep mode and adjustable delivery temperature for saving energy

Hands-free filling

Safety lock feature

Superior 5 micron filter

Up to 20L boiling water p/hr

Sink or sink-free installation

**Refer to page 20 for specifications**

## On-Tap (tap plus mixer)



Works independently from your existing hot water system - cold water supply only required

Available in two designs with matching mixer tap

Hands-free filling

Safety lock feature

Energy saving - sleep mode and adjustable delivery temperature

Up to 20L boiling water p/hr

Sink installation

**Refer to page 20 for specifications**

# SPECIFICATIONS

## MAINS PRESSURE – VITREOUS ENAMEL (VE)

Product		Models													
Single Element Indoor		31202519V	31204515	31209015	31213513	32213515	31218013		32218015	31225015	31230015				
			31204513	31209013	31213515	32213513	31218015		32218013						
Twin Element (non-simultaneous) Indoor							31218025			31225025					
Dual Element (simultaneous) Indoor												31230033	31230055		
Optima Outdoor/Indoor								91318015							
Optima Twin Element (non-simultaneous) Outdoor/Indoor														91330025	492400G8
Approx. Storage Capacity	Litres	25	45	90	135	135	180	180	180	250	300	300	300	300	400
Boost Capacity (Twin Element)	Litres	-	-	-	-	-	45*	-	-	50**	-	-	-	47	90
Height	A (mm)	398	525	925	1325	935	1710	1720	1165	1555	1815	1815	1815	1820	1840
Width	B (mm)	400	490	490	490	580	490	490	580	580	580	580	580	580	690
	C (mm)	116	120	120	120	120	120	120	120	120	120	120	120	120	120
	D (mm)	32	65	65	65	65	65	-	65	65	-	65	65	-	105
	E (mm)	-	-	-	-	-	-	-	-	-	-	162	162	-	-
	F (mm)	-	-	-	-	-	1182*	-	-	1126**	-	-	-	1298	1323
	G (mm)	246	-	-	-	-	-	1546	-	-	-	-	-	1636	1479
	H (°)	45	45	45	45	45	45	36	45	45	45	45	45	36	97
Approx Weight Empty	Kg	15	26	38	49	54	60-62	64	64	80-82	91	91	91	97	113
TPR Valve Setting	kPa	1000	1000	1000	1000	1000	1000	1000	1000	1000	1000	1000	1000	1000	1000
Water Connections		RP ¾ /20	RP ¾ /20	RP ¾ /20	RP ¾ /20	RP ¾ /20	RP ¾ /20	RP ¾ /20	RP ¾ /20	RP ¾ /20	RP ¾ /20	RP ¾ /20	RP ¾ /20	RP ¾ /20	RP ¾ /20
Element Rating (@230V)	kW	2.0	2.0 or 3.0	2.0 or 3.0	2.0 or 3.0	2.0 or 3.0	2.0 or 3.0	3.0	2.0 or 3.0	3.0	3.0	2 x 3.0kW (or 6.0)	2 x 5.0kW (or 10.0)	3.0	4.8*

\*31218025 only \*\*31225025 only ^ @ 240V

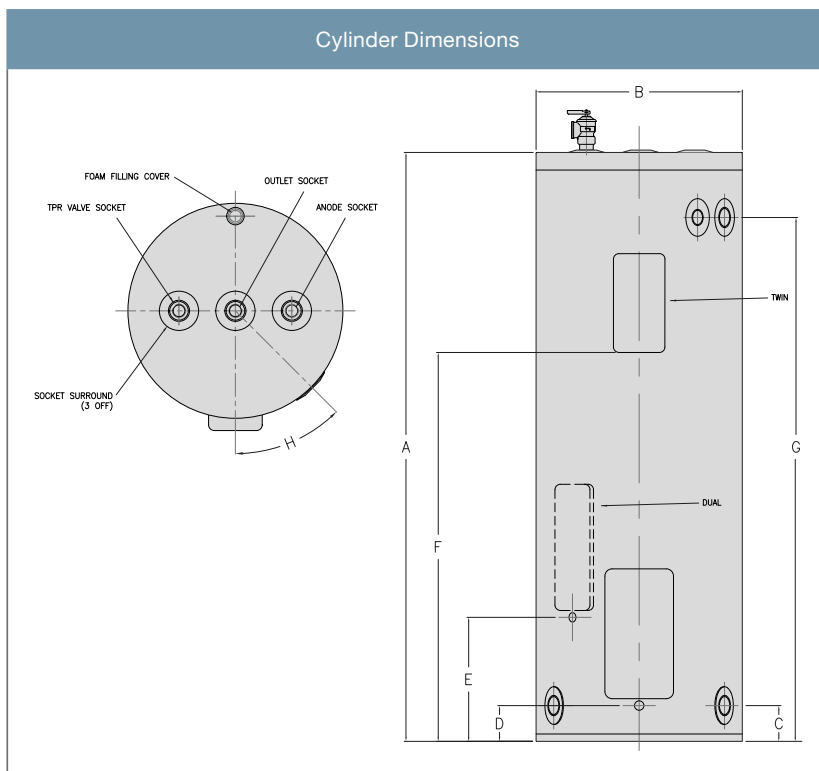

- Inlet/Outlet and tpr valve are side mounted on left-hand side of 31202519V.
- Inlet/outlet and TPR valve are side mounted on right-hand side of 91318015 and 91330025.
- Diagram does not apply to 492400G8. The 400L Optima Cylinder has dual handed fittings.

### Specifications Electric (@230V)

kW	Recovery on a 50°C rise	AMPS
2.0 kW	34 litres per hr	8.7 A
2.4 kW	40 litres per hr	10.4 A
3.0 kW	51 litres per hr	13.1 A
3.6 kW	62 litres per hr	15.7 A
4.8 kW	82 litres per hr	21.0 A
5.0 kW	85 litres per hr	21.8 A
6.0 kW	103 litres per hr	26.1 A
2 x 3.0 kW	103 litres per hr	26.2 A
2 x 5.0 kW	171 litres per hr	43.6 A



# MAINS PRESSURE – STAINLESS STEEL

Rheem Stainless Steel Mains Pressure Electric*					
	Screw-in	32513513 32513515	32518013 32518015	32525015	32530015
Approx. Storage Capacity	Litres	135	180	250	300
Weight Empty	Kg	30	37.5	41	48
Inlet/Outlet Connections				RP 3/4" / 20	
Solar/HP Feed Connection		-		RP 3/4" / 20	
Solar/HP Return Connection		-		RP 3/4" / 20	
TPR Valve Connection				RP 1/2" / 15	
TPR Valve Setting	kPa	1000	1000	850	850
Dimensions:	mm				
A		1350	1770	1620	1910
B		490	490	580	580
C		195	200	205	205
D		1170	1575	1395	1690
E		-	550	605	605
Element Rating	kW	2.0 or 3.0	2.0 or 3.0	3.0	3.0
Top Element Rating (kit-set)	kW	-	2.0	3.0	3.0
Boost Capacity (Twin Element)	Litres	-	60	110	135

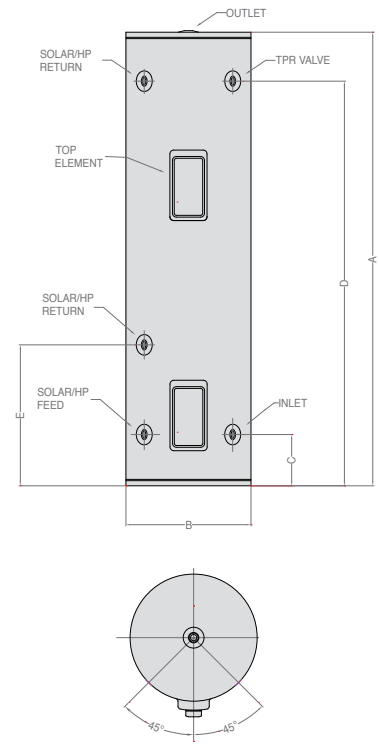

# MAINS PRESSURE – STAINLESS STEEL COIL

Description	Connection	Lower Coil		Mid Coil		Dual Coil	
		35625015LL 35625015LR	35630015LL 35630015LR	35625015ML 35625015MR	35630015ML 35630015MR	35625015DL	35630015DL
Models	L = Left R = Right						
Approx. Storage Capacity		250L	300L	250L	300L	250L	300L
Cylinder Diameter (mm)		560	560	560	560	560	560
Cylinder Height (mm)		1725	2045	1725	2045	1725	2045
A Hot Water Draw-Off	3/4" BSP F	1725*	2045*	1725*	2045*	1725*	2045*
B Right/Left Cold Feed (High Pressure) Inlet	3/4" BSP F	200*	200*	200*	200*	200*	200*
C Left/Right Cold Feed (High Pressure)	3/4" BSP F	200*	200*	200*	200*	-	-
D Safety TPR	3/4" BSP F	1500*	1810*	1500*	1810*	1500*	1810*
E From Solar (Inlet)/Heat Pump Return Kit set	3/4" BSP F	370*	370*	370*	370*	370*	370*
F To Solar/Heat Pump (Direct Outlet)	3/4" BSP F	200*	200*	200*	200*	370*	370*
G Secondary Solar/Wetback Flow (Coil)	3/4" BSP F & 1" BSP M	685*	685*	1285*	1285*	1340*	1340*
H Secondary Solar/Wetback Return (Coil)	3/4" BSP F & 1" BSP M	245*	245*	485*	485*	540*	540*
J Lower Element (3kW)	1 1/4" BSP F	-	-	-	-	-	-
K Upper Element*** (3kW)	1 1/4" BSP F	-	-	-	-	-	-
L Sensor Probe Pocket	Ø8.5mm x 120mm Tube	-	-	-	-	-	-
M1 Coil*		10m	10m	10m	10m	10m	10m
M2 Coil*		-	-	-	-	7.6m	7.6m

F = Female M = Male \*Fitting heights measured from bottom of cylinder (mm).

All measurements are nominal.

\*\*Compressed solar coils require a pumped base system.

\*\*\*Upper element supplied plugged. Element and thermostat kit sold as optional extra (part 417026).

All cylinders supplied with 46kW TPR Valve 850kPa.

^Incoming heat source of 80°C

= nominal 25kW for M1 Coil

= nominal 20kW for M2 Coil

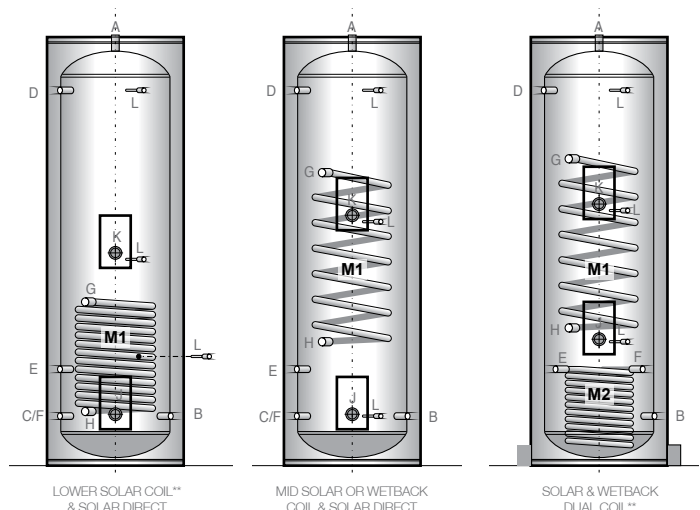

## LOW PRESSURE – VITREOUS ENAMEL (VE)

Models		148 090 **T	148 135 **T	158 135 **T	148 180 **T	158 180 **T	158 270 15T
Approx. Storage Capacity (L)		90	135	135	180	180	270
Height	A (mm)	915	1315	880	1710	1135	1640
Width	B (mm)	490	490	580	490	580	580
	C (mm)	120	120	120	120	120	120
	D (°)	45	45	36	45	36	36
Approx weight Empty (Kg)		29	39	40	51	53	85
Pressure Rating (kPa)		120	120	120	120	120	120
Element Rating (@230v) (kW)		2.0 or 3.0	2.0 or 3.0	2.0 or 3.0	2.0 or 3.0	2.0 or 3.0	3.0

\*\*Add to end of product code: 13T for 2kW; or 15T for 3kW

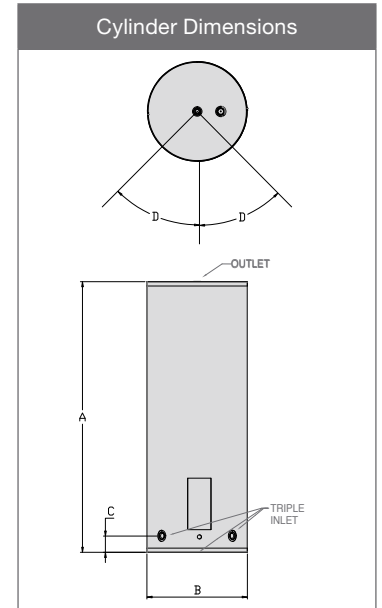

## LOW PRESSURE – COPPER

Model	Cap. (L)	w x h (mm)	ELM. (kW)	Inlet
LP DOMESTIC INDOOR ELECTRIC STORAGE (COPPER)				
149 040 13	40	460 x 490	2	Bottom
14T 090 13	90	510 x 785	2	Triple
14T 110 13	110	510 x 950	2	Triple
12T 135 13	135	610 x 800	2	Triple
14T 135 13	135	560 x 955	2	Triple
16T 135 13	135	510 x 1140	2	Triple
18T 135 13	135	460 x 1465	2	Triple
54T 135 13	135	540 x 1030	2	Triple
12T 180 13	180	610 x 1020	2	Triple
12T 180 15	180	610 x 1020	3	Triple
14T 180 13	180	560 x 1220	2	Triple
14T 180 15	180	560 x 1220	3	Triple
54T 180 13	180	540 x 1355	2	Triple
54T 180 15	180	540 x 1355	3	Triple
16T 180 13	180	510 x 1510	2	Triple
16T 180 15	180	510 x 1510	3	Triple
149 225 15	225	610 x 1250	3	Bottom
169 225 15	225	560 x 1510	3	Bottom
149 270 15	270	610 x 1470	3	Bottom
149 270 25	270	610 x 1470	2 x 3	Twin element (simultaneous)
169 270 15	270	560 x 1800	3	Bottom
169 270 25	270	560 x 1800	2 x 3	Twin element (simultaneous)
149 350 25	350	655 x 1595	2 x 3	Twin element (simultaneous)

### LP DOMESTIC INDOOR ELECTRIC STORAGE (COPPER) UNDERBENCH

Model	Cap. (L)	w x h (mm)	ELM. (kW)	Inlet
199 015 13	15	365 x 370H	2	Top Inlet & Outlet
199 025 13	25	365 x 525H	2	Top Inlet & Outlet
199 040 13	40	460 x 490H	2	Top Inlet & Outlet

Model	Cap. (L)	w x h (mm)	ELM. (kW)	Inlet
LP HEAVY HEAD				
146 180 15	180	560 x 1220H	3	Bottom
166 180 15	180	510 x 1510H	3	Bottom
LP TANK UNITS				
T49 135 13	135	560 x 1260H	2	
T49 180 15	180	560 x 1530H	3	
LP DAIRY				
109 250 1G	250	760 x 1235H	3/3	
109 350 1G	350	760 x 1530H	3/3	
109 450 1G	450	760 x 1835H	3/3	
109 600 1G	600	840 x 1885H	3/3	

1. The Low Pressure Copper cylinders have a Pressure Rating of 76kPa
2. The Heavy Head models in the Low Pressure range are pressure rated to 120kPa

# LOW PRESSURE – COPPER WETBACK

Model	Approx. Storage Capacity	Dimensions w x h (mm)	Element Rating (kW)	Connection
145 135 13	135L	560 × 955H	2	BCRL
165 135 13	135L	510 × 1140H	2	BCRL
185 135 13	135L	460 × 1465H	2	BCRL
125 180 15	180L	610 × 1020H	3	BCRL
143 180 15	180L	560 × 1220H	3	RHSC
144 180 15	180L	560 × 1220H	3	LHSC
145 180 15	180L	560 × 1220H	3	BCRL
545 180 13	180L	540 × 1355H	2	BCRL
545 180 15	180L	540 × 1355H	3	BCRL
165 180 15	180L	510 × 1510H	3	BCRL
145 225 15	225L	610 × 1250H	3	BCRL
165 225 15	225L	560 × 1520H	3	BCRL
145 270 15	270L	610 × 1465H	3	BCRL
165 270 15	270L	560 × 1800H	3	BCRL

# GAS STORAGE

Product		Outdoor Models		Indoor Models	
		850330N0Z	850360N0Z	441135NO	441170NO
Rheem Gas Storage				441135NO	441170NO
Stellar® Gas Storage		850330N0Z	850360N0Z		
Approx. Storage Capacity	Litres	130	160	130	160
Hourly Gas Consumption (Natural Gas)	MJ	42	42	29	33
Height	A (mm)	1600	1900	1555	1855
Width	B (mm)	485	485	430	430
Depth	C (mm)	558	558	515	515
	D (mm)	988	1213	N/A - Outlet on Top	N/A - Outlet on Top
	E (mm)	328	409	332	407
	F (mm)	298	298	300	300
	G (mm)	-	-	1475	1775
	H (mm)	-	-	75	75
Approx Weight Empty	Kg	70	80	50	69
TPR Valve Setting	kPa	1400	1400	1000	1000
Water Connections (LHS)		RP 3/4 /20	RP 3/4 /20	RP 3/4 /20	RP 3/4 /20
Gas Connection		RP 1/2 /15	RP 1/2 /15	RP 1/2 /15	RP 1/2 /15

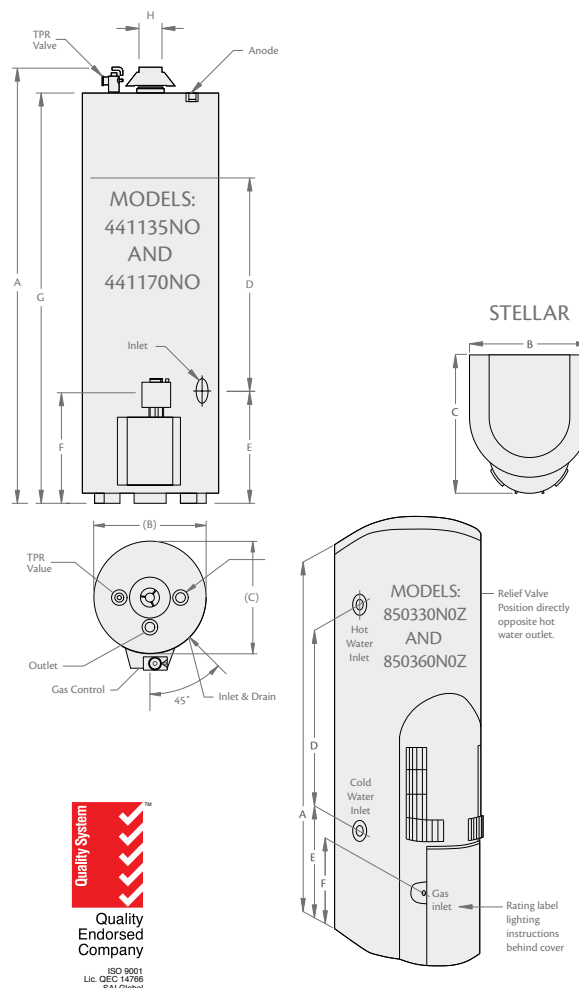

# GAS CONTINUOUS FLOW

	Rheem 16	Rheem 20	Rheem 26	Rheem 27	Indoor 27*
Model Number	874A16NFZ 874A16LFZ	874820LFZ 874A20NFZ	874826LFZ 874A26NFZ	874627NFZ 874627LPZ	864627NFZ 864627LPZ
Nominal L/Min @25°C Rise	16L/Min	20L/Min	26L/Min	27L/Min	27L/Min
Gas Input Max	126 MJ/hr	157 MJ/hr	199 MJ/hr	205 MJ/hr	205 MJ/hr
Gas Type	NG or ULPG	NG or ULPG	NG or ULPG	NG or ULPG	NG or ULPG
Gas Connection	R ¾ / 20	R ¾ / 20	R ¾ / 20	R ¾ / 20	R ¾ / 20
Min Gas Supply Pressure NG/ULPG	1.13 kPa/ 2.75 kPa	1.13 kPa/ 2.75 kPa	1.13 kPa/ 2.75 kPa	1.13 kPa/ 2.75 kPa	1.13 kPa/ 2.75 kPa
Water Pressure (kPa) Min-Max	120-1000	120-1000	120-1000	140-1000	140 - 1000
Minimum Flow Rate	2.0L/Min	2.0L/Min	2.0L/Min	2.0 L/Min	2.0 L/Min
Cold Water Connection	R ¾ / 20	R ¾ / 20	R ¾ / 20	R ¾ / 20	R ¾ / 20
Hot Water Connection	R ¾ / 20	R ¾ / 20	R ¾ / 20	R ¾ / 20	R ¾ / 20
Approx. Weight (empty)	16kg	16kg	16kg	23kg	24kg
Freeze Protection	Yes	Yes	Yes	Yes	Yes
A Unit Height (mm)	520	520	520	601	650
B Unit Width (mm)	355	355	355	351	351
C Unit Depth (mm)	187	187	187	226	240
D Hot Water Outlet (mm)	105	105	105	132	132
E Gas Inlet (mm)	83	83	83	127	127
F Cold Inlet (mm)	10	10	10	28	28
G Gas Inlet (mm)	77	77	77	97	119
H Cold Inlet (mm)	68	68	68	64	86
J Hot Water Outlet (mm)	87	87	87	84	107
Gas Energy Rating	6 Stars	6 Stars	6 Stars	6 Stars	6 Stars

Continuous Flow Accessories	Part Number
Horizontal Flue Kit Side Exit	318278
Horizontal Flue Kit Rear Exit	318279
Vertical Flue Kit	318280
Recess Box - For Rheem 27	320316
Recess Box - For Rheem 16, 20 & 26 874 Series	318994
Pipe Cover - For Rheem 27	320116
Pipe Cover - For Rheem 16, 20 & 26	320117
EZ LINK® Cable	290141
Standard Kitchen Temperature Controller	A299850
Standard Bathroom 1 Temperature Controller	A299851
Standard Bathroom 2 Temperature Controller	A299852
Recess door only 874A Series - 16L, 20L & 26L	320759
Recess Box 874A Series - 16L, 20L & 26L	320758
Flue Divertor (Standard) - Natural Gas only	299336
Flue Divertor (Extended) - Natural Gas only	299334

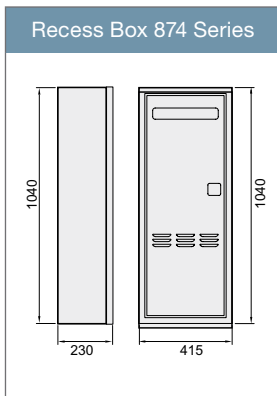
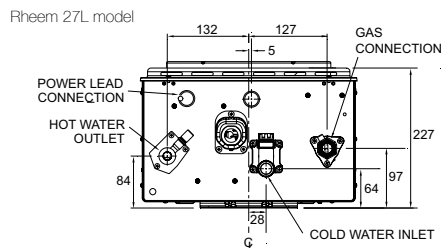
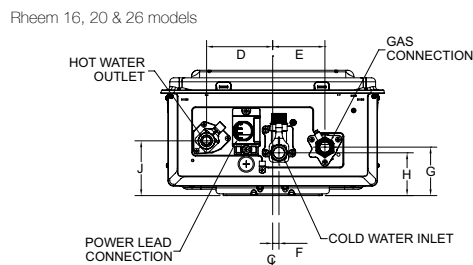
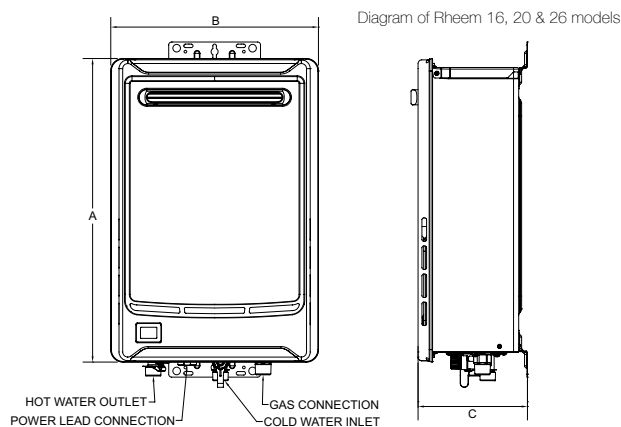

**\*Rheem 27 Indoor Flue System**

A certified Rheem coaxial flue system must be used with all Rheem 27 indoor models. There are three indoor flue kits available:- Horizontal Side Exit, Horizontal Rear Exit and Vertical. Please contact your local plumber, plumbing merchant or Rheem Customer Service on 0800 657 336 to discuss the best solution for your needs. The Rheem flue system uses a twin pipe design (one pipe inside the other) ; an inner pipe of stainless steel for exhaust, and an outer steel pipe for inlet air. This flue system can exhaust either through a roof or wall. (Subject to Building Regulations).

# HEAT PUMP

		AMBIPOWER® 280e	AMBIHEAT® HDC 270	AMBIPOWER® HDC 180
Code		A551E280R5	A55127005	A551180C5
Approx Storage Capacity	Litres	280	270	180
Height	mm	1832	1825	1810
Width	mm	696	690	532
Depth	mm	725	720	576
Approx Weight empty	kg	135kg	135kg	116kg
Litres per hour at 19°C		56	77	60
TPR Valve Setting	kPa	1000	1000	1000
Water Connections		RP ¾	RP ¾	RP ¾
Element Rating	kW	2.4	2.4	2.4
No of People		Up to 6	Up to 6	Up to 4
Installation Location		Outdoors	Outdoors	Outdoors
COP (at 19°C)		5.2	4.4	4.5

Temperature Zones	AMBIPOWER® 280e	AMBIHEAT® HDC 270	AMBIPOWER® HDC 180
Model Code	A551E280R5	A55127005	A551180C5
Outside Operating Temperature range for use	-6°C to +43°C	-5°C to +43°C	-7°C to +43°C
Can be installed in Zone	1 and 2	1 and 2	1 and 2

Zone 1 and 2 includes all areas of New Zealand.

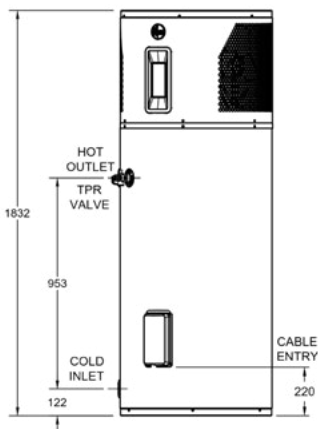
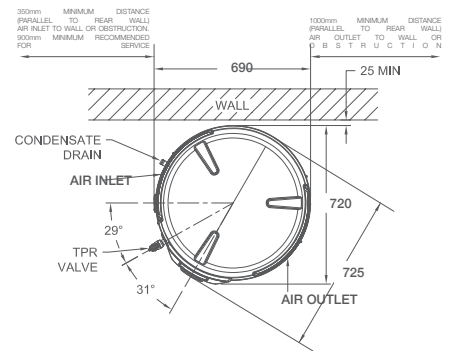
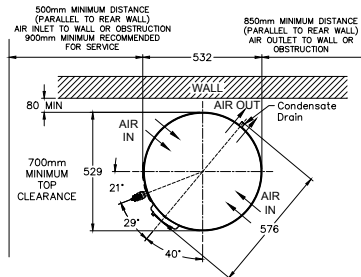
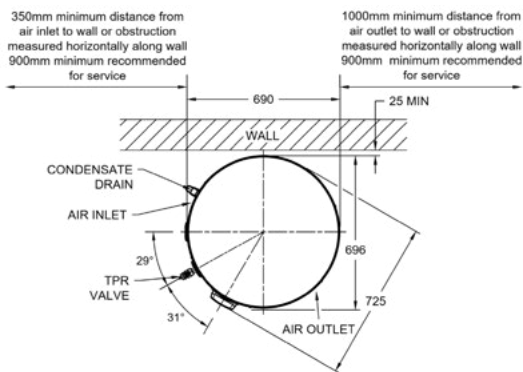

AmbiPower® 280e Dimensions

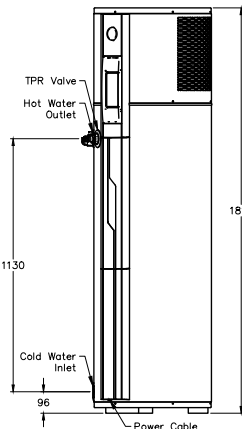

AmbiPower® HDC-180 Dimensions

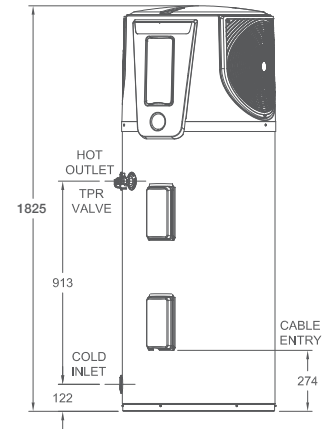

AmbiHeat® HDC-270 Dimensions

# ECLIPSE® ELECTRIC CONTINUOUS FLOW

	18kW 50°C WATER HEATER	18kW 60°C WATER HEATER	27kW 50°C WATER HEATER	27kW 60°C WATER HEATER
Electrical Connection	380 - 415V, AC 3 Phase 3 wire and earth, 50Hz	380 - 415V, AC 3 Phase 3 wire and earth, 50Hz	380 - 415V, AC 3 Phase 3 wire and earth, 50Hz	380 - 415V, AC 3 Phase 3 wire and earth, 50Hz
Rated Power (kW)	18	18	27	27
Amps/phase	26	26	37.6	37.6
Maximum Flow Rate	7.4 – 7.7 L/min1	7.4 – 7.7 L/min1	12 L/min	12 L/min
Water Connection	G1/2 Elbow / R1/2 Straight	G1/2 Elbow / R1/2 Straight	G1/2 Elbow / R1/2 Straight	G1/2 Elbow / R1/2 Straight
Minimum Activation Flow Rate	2.8 L/min	2.8 L/min	2.8 L/min	2.8 L/min
Water Supply Pressure (Min)	100 kPa	100 kPa	100 kPa	100 kPa
Water Supply Pressure (Max)	750 kPa	750 kPa	750 kPa	750 kPa
Pressure Drop at 7 L/min	115 kPa	115 kPa	115 kPa	115 kPa
Pressure Drop at 12 L/min	280 kPa	280 kPa	280 kPa	280 kPa
Minimum Water Resistivity	≥800Ω.cm	≥800Ω.cm	≥800Ω.cm	≥800Ω.cm
Element Nos	3	3	4	4
Element Material	Ni80Cr20	Ni80Cr20	Ni80Cr20	Ni80Cr20
Temperature Control Range	30 – 55°C3	30 – 60°C	30 – 55°C3	30 – 60°C
IP Rating	IP25	IP25	IP25	IP25
Dimensions	470Hx 226Wx95D mm	470Hx 226Wx95D mm	470Hx 226Wx95D mm	470Hx 226Wx95D mm
Weight (empty) Approx	4.5kg	4.5kg	4.5kg	4.5kg
Domestic Warranty	5 years parts and labour	5 years parts and labour	5 years parts and labour	5 years parts and labour
Commercial Warranty	1 year parts and labour	1 year parts and labour	1 year parts and labour	1 year parts and labour

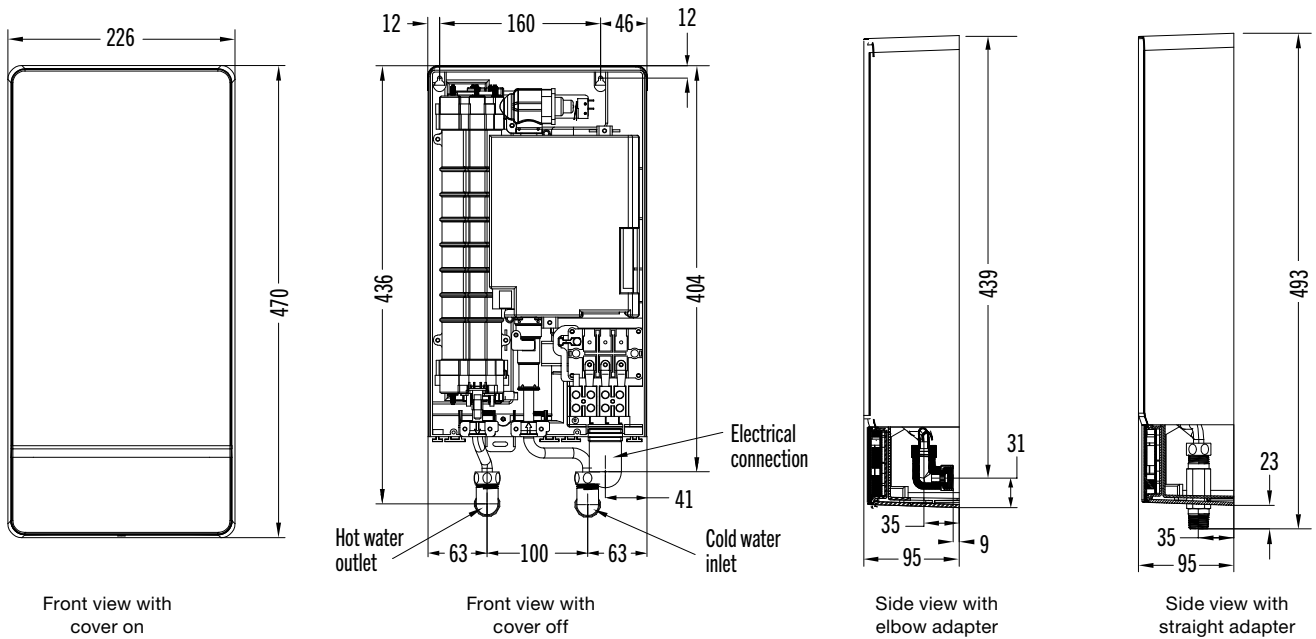

# ON-TAP FILTERED, CHILLED AND BOILING WATER

Rheem On-Tap Series		On-Tap 3L	On-Tap 5L	On-Tap Plus 5L	Push-thru 1.8L Chiller
On-Tap Aqua®		743003F	743005F		318844
On-Tap Azure®		743103F	743105F		
On-Tap Plus Aqua®				7430054SR	
On-Tap Plus Azure®				7431054DR	
Boiling Delivery – p/hr	Litres	16.6	20	20	-
Boiling Delivery – p/hr	Cups*	98	118	118	-
Mixed Delivery – p/hr <sup>^</sup>	Litres	-	-	57	-
Chilled Delivery – p/hr	Litres	-	-	-	12.5
Chilled Delivery – p/hr	Glasses**	-	-	-	63
Weight empty	Kg	12	12	12	12
Weight full	Kg	18	18	18	14
Recommended Min water pressure	kPa	300	300	300	140
Max water pressure	kPa	500	500	500	400
Element	kW	1.5	1.8	1.8	-
Electrical connections		10 amp 3 pin plug and flex			
Plumbing connections		½" BSP			
A Width (mm)		175	175	175	205
B Depth (mm)		460	460	460	408
C Height (mm)		405	405	405	278
Accessories	Part No				
Aqua® Sink Free & Extension Kit	317453	Optional	Optional	Optional	
Azure® Sink Free & Extension Kit	319042	Optional	Optional	Optional	
Azure® Combined Base Sink Free & Extension Kit	319047	Optional	Optional	Optional	

\*Cup size 170ml \*\*Glass size 200ml ^ @ 50°C

Calculations based on incoming water temperature of 17°C

## DISPENSING TAPS

Aqua®

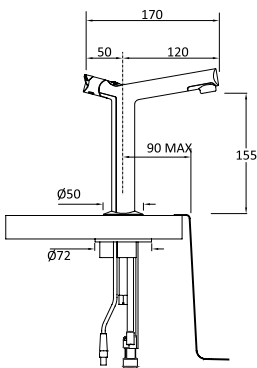

Azure®

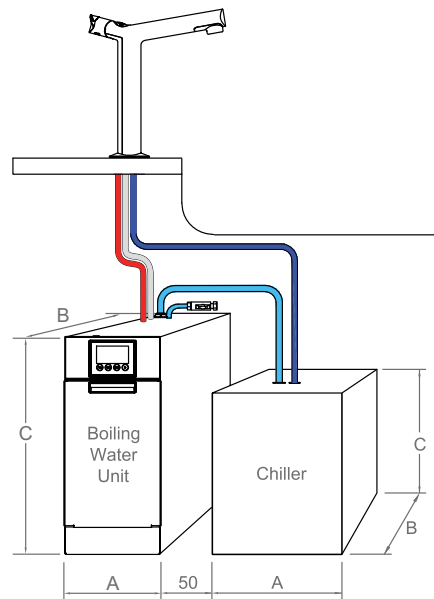
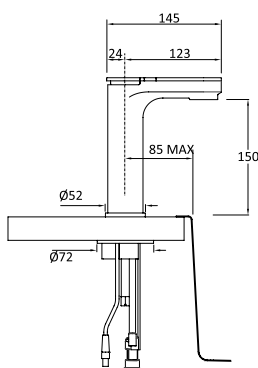

## MIXER TAPS

Aqua®

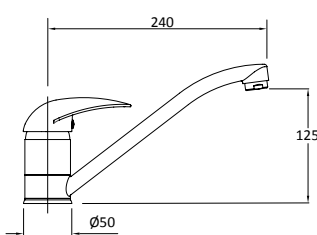

Azure®

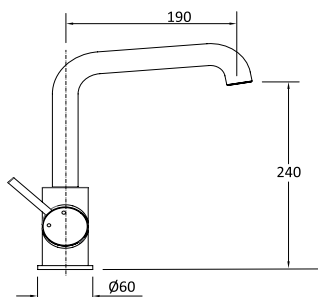

# LAZER® BOILING WATER

Lazer® Boiling Water Unit		Lazer® Office		Lazer®Eco			Lazer® Commercial				
White		70103W-NZ	70105W-NZ	70303W-NZ	70305W-NZ	70307W-NZ	70207W-NZ	70210W-NZ	70215W-NZ	70225W-NZ	70240W-NZ
Stainless Steel		70103S-NZ	70105S-NZ				70207S-NZ	70210S-NZ	70215S-NZ	70225S-NZ	70240S-NZ
Capacity	Litres	3	5	3	5	7.5	7.5	10	15	25	40
Delivery – Initial	Litres	3.5	6	3.5	6	8.5	8.5	11	17	27	42
	Cups*	21	35	21	35	50	50	65	100	159	247
Recovery	L/hr	17.5	23	17.5	23	23	23	23	23	35	45
– Cups per hour	Cups*	103	135	103	135	135	135	135	135	206	265
Weight empty	Kg	6	8	6	8	9	9	10	15	17	19
Weight full	Kg	10	15	10	15	19	19	22	34	47	67
Min water pressure	kPa	50	50	50	50	50	50	50	75	75	100
Max water pressure	kPa	1000	1000	1000	1000	1000	1000	1000	1000	1000	1000
Element Rating @ 240V	kW	1.8	2.4	1.8	2.4	2.4	2.4	2.4	2.4	3.6	4.6
Electrical connections		Supplied with 10 amp 3 pin plug and flex								Hard-wired	
Plumbing connections		G ½ ( ½ BSP)									
A Width		285	334	283	336	336	336	336	336	336	490
B Depth		209**	241**	160	192	192	192	192	299	299	340
C Height		435	465	435	465	515	515	615	515	720	615
D		–	–	280	312	312	312	312	419	419	460
E		65	65	65	65	65	65	65	65	65	65
F		70**	70**	45	45	45	45	45	45	45	45
G		33	33	50	50	50	50	50	50	50	50
H		20	20	23	23	23	23	23	23	23	23
M		142	167	142	168	168	168	168	168	168	245
N		174**	210**	238	270	270	270	270	377	377	418

\*Cup size 170ml \*\*Includes 25mm for supplied backing plate.

Calculations based on incoming water temperature of 18°C

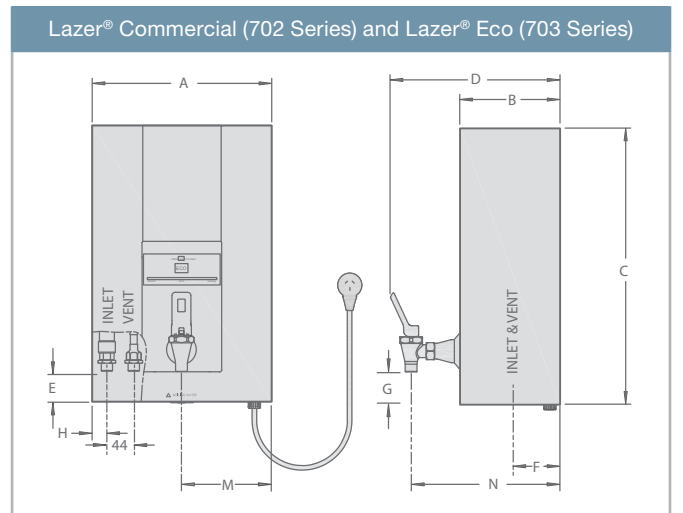
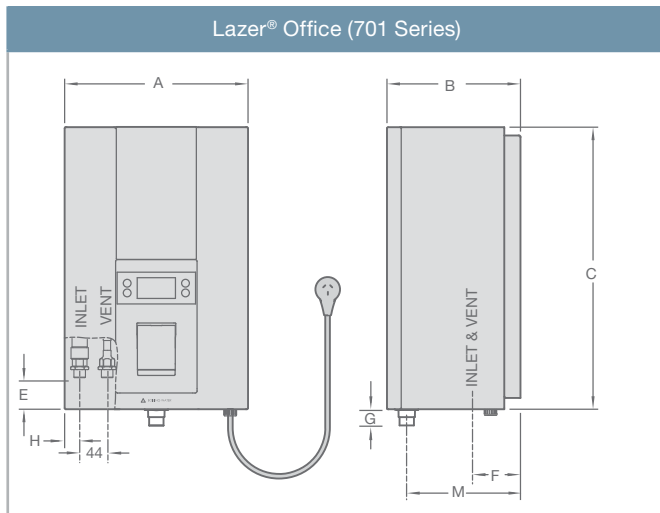

# ZIP® BOILING WATER

Models	83204514	83207014	83215014	83223014	83235014
Delivery Capacity (L)	4.5	7.0	15	23	34
Dimension A mm	340	340	490	490	490
Dimension B mm	180	180	180	235	325
Dimension C mm	430	515	615	615	615
Weight Empty (kg)	9	10	15	17	20
Weight Full (kg)	16	20	35	45	62
Element Rating @ 240V (kW)	2.4	2.4	2.4	2.4	2.4

Approximate Heat Up Times From Cold (18°C)					
Maximum Level (mins)	16	23	46	67	102
Minimum Level (mins)	4	6	14	24	28

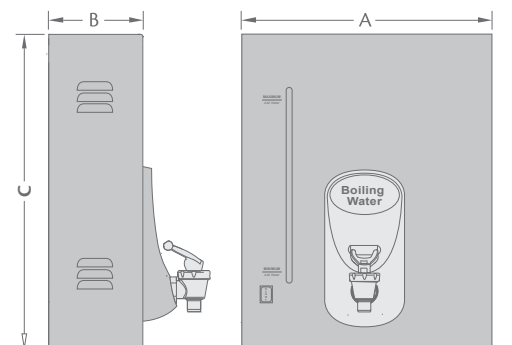

# DOMESTIC WARRANTIES\*

## ELECTRIC

Mains Pressure Electric Vitreous Enamel Indoor  
10 years tank, 5 years tank labour, 1 year parts and labour.

Mains Pressure Electric Vitreous Enamel Optima  
12 years tank, 5 years tank labour, 3 years parts and labour.

Mains Pressure Electric Stainless Steel & Coil  
10 years tank, 3 years tank labour, 1 year parts and labour.

Low Pressure Electric Vitreous Enamel  
10 years tank, 5 years tank labour, 1 year parts and labour.

Low Pressure Electric Copper  
5 years tank, 1 year tank labour, 1 year parts and labour.

Eclipse® Electric Continuous Flow  
5 years unit, 5 years parts and 1 year labour.

## GAS

Gas Continuous Flow  
10 years on heat exchanger, 3 years parts and labour.

Mains Pressure Gas Storage  
5 years tank, 1 year tank labour, 1 year parts and labour.

Stellar® Gas Storage  
10 years tank, 5 years tank labour, 1 year parts and labour.

## HEAT PUMP

Ambiheat® Heat Pump  
7 years tank, 3 years tank labour, 1 year parts and labour.  
3 years sealed system including labour.

AmbiPower® HDC-180 Heat Pump  
7 years tank, 3 years tank labour, 1 year parts and labour.  
3 years sealed system including labour.

Ambiheat® 280e Heat Pump  
7 years tank, 3 years tank labour, 1 year parts and labour.  
3 years sealed system including labour.

## BOILING WATER

Lazer® Office, Eco & Commercial & On-Tap  
Boiling Water Unit  
5 years tank, 2 years tank labour, 2 years parts and labour

Zip® Boiling Water Unit  
5 years tank, 1 year tank labour, 1 year parts and labour

\*The water heater warranties listed on this page are for single family premises in a domestic application. These warranties apply to New Zealand only.  
For Raypak and Rheem Commercial Warranty information, call 0800 667 336 or visit [www.rheem.co.nz](http://www.rheem.co.nz)



## Solar Solutions

The solar revolution has started and we are leading the charge with thoughtful, high-quality solutions.

Our product range is built to withstand New Zealand's ever-changing weather conditions, and we have a smart solar solution for every Kiwi.

Looking for further ways to save on energy bills?

Look no further than Rheem Solar

[rheem.co.nz/solar](http://rheem.co.nz/solar)



# Join the smart energy revolution



**Install a Rheem®**

**Rheem New Zealand Limited**

475 Rosebank Road, Avondale 1026, PO Box 19011, Avondale, Auckland 1746. Freephone 0800 657 336 – [www.rheem.co.nz](http://www.rheem.co.nz)  
All specifications contained in this brochure are subject to change without notice. Please check the specifications are current at the time of ordering. All information is current at the time of publication (January 2025).