

Camlocks

Important Information

The lock end nut, washers and stop plates have been assembled to suit light duty conditions. The maximum tightening torque for lock end nut is 4 Nm (approx 36lb/ins)

EXCESS TORQUE MAY DAMAGE THE BRASS THREADS

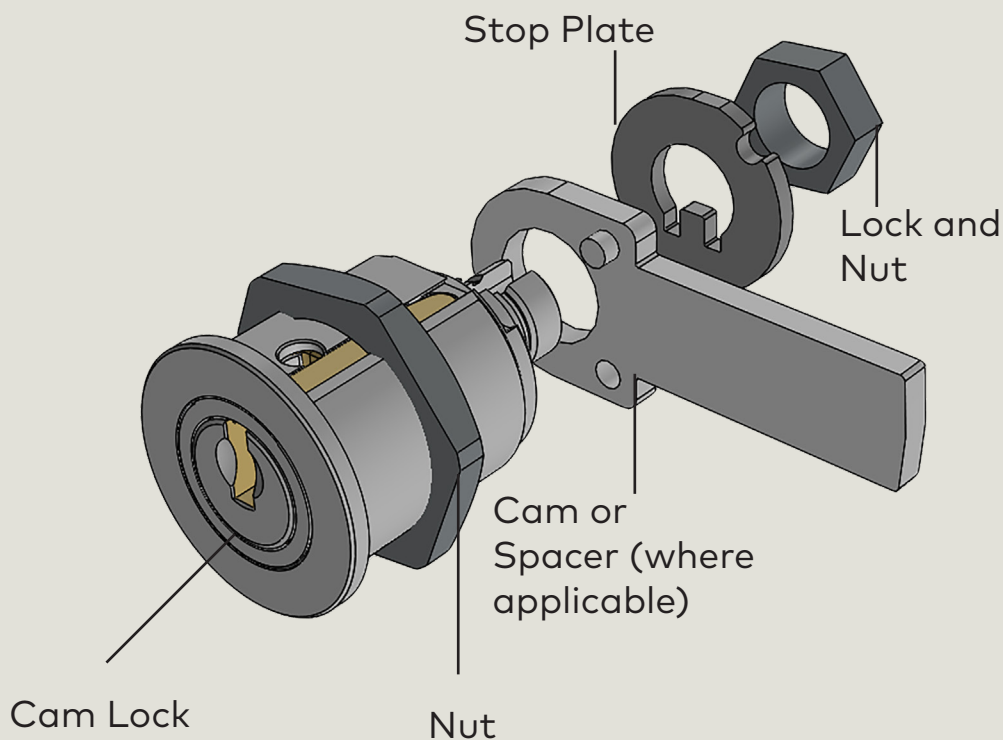

For re-tightening of locknut the use of a torque wrench is recommended.