

Application Guide for MasterBrace FRP Strengthening Systems

MasterBrace Laminate, MasterBrace MBar, MasterBrace Fibre &
MasterBrace Anchor

IMPORTANT: READ THIS FIRST

MB Solutions Australia Pty Ltd does not warrant the performance characteristics of this product unless the instructions of this document and other related MB Solutions Australia Pty Ltd documents are adhered to in all respects.

Table of Contents

General Information	3
System components	
Part A – Preparation	6
A1. Concrete Substrate	
A2. Concrete Flatness	
A3. Levelling of the Substrate	
A4. Environmental Conditions	
A5. Set-out	
A6. Near-Surface Mounted	
Part B- General Application	10
B1. Working with Epoxy Resins	
B2. Priming with MasterBrace P 3500	
Part C - MasterBrace Laminate (and Bar)	11
C1. Handling	
C2. Application of MasterBrace Laminate (summary)	
C3. Preparation of MasterBrace Laminates (and Bar)	
C4. Application of MasterBrace 4000 adhesive	
C5. Application of the MasterBrace Laminate	
C6. Application of the MasterBrace NSM Bar and Laminate	
Part D – MasterBrace Fabric	20
D1. Handling	
D2. Application of MasterBrace Fabric(summary)	
D3. Preparation of MasterBrace Fabric	
D4. Application of the MasterBrace Fabric	
D5. Repair of MasterBrace Fabric	
Part E – MasterBrace Anchor	27
E1. Handling	
D2. Application of the MasterBrace Anchor	
Part F- Other Considerations	28
F1- Quality control	
F2- Repair Techniques	
F3- Heat Protection Measures	
F4- Cold Weather Application/Accelerated Curing	
F5- Hot Weather Application	
Appendix A - General Description of Tensile Adhesion Test	31
Appendix B - Application of Hot Mix Asphalt	33
Appendix C - Procedure for removal of peel-ply	34

General

This application guide applies to the MB Solutions Australia Ltd FRP (Fibre Reinforced Polymer) Composite Strengthening systems, known as **MasterBrace**. It specifically deals with the pre-formed (pultruded), MasterBrace Laminate Plate (and MasterBrace Bar types), as well as the MasterBrace Fabric type FRP systems. This application guide shall be read in conjunction with all project specifications (including drawings), by others, and the current material technical data sheets (TDS) and safety data sheets (SDS).

CARBON FIBRE FABRICS	
supplied in: 25-100m rolls and 500mm wide Strength 4500 MPa, E-Modulus 240 GPa	
MasterBrace FIB [GSM]/50 CFS	
MasterBrace FIB fabrics are available in 200, 230 300, 400, 450, 600 and 900 GSM.	
High Modulus fabrics type CLM are available as made to order and may be subject to minimum order quantities.	
Specially designed fabric style, width and length to meet the specific project requirements are also available upon request.	
Other fabrics such as Aramid (for Impact resistance) as well as Glass (for Siesmic) fibres are available.	

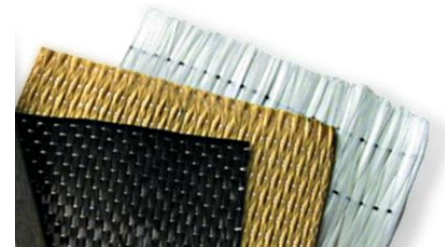

HIGH STRENGTH CARBON LAMINATE		
supplied in: 100m rolls Strength 3000 MPa, E-Modulus 170 GPa		
MasterBrace LAM width/ thickness CLS e.g MasterBrace LAM 120/1.4 CLS	80, 100, 120, 150 mm width	1.4 mm thick W peel ply
MasterBrace LAM 120/2.8 CLS (Surface Mounted)	120 mm width	2.8 mm thick W peel ply
MasterBrace LAM 15/2.5 CLS (Near Surface Mounted)	15 mm width	2.5 mm thick W peel ply
Other widths and thicknesses are available as made to order and subject to minimum order quantity.		
High Modulus laminates type CLM are available in various widths subject to minimum order quantity, and made to order.		



CARBON FIBRE ANCHORS

MasterBrace Anchor 8 CA	Ø8mm
MasterBrace Anchor 9.5 CA	Ø9.5mm
Length pultruded part:	150mm
Length Dry part:	200mm



CARBON FIBRE ROD

supplied in: 100m rolls Strength >2500 MPa, E-Modulus >155GPa

MasterBrace MBAR 8 CR	8 mm diameter W peel ply
MasterBrace MBAR 10 CR	10 mm diameter W peel ply
MasterBrace MBAR 12 CR	12 mm diameter W peel ply

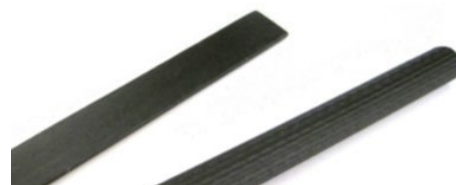

OTHER PART OF MASTERBRACE BUILDUP SYSTEM

MasterBrace P 3500	Epoxy primer	4-5 m ² /lt
MasterBrace 4500	High strength epoxy saturant for Fabric	~0.7-1.0 lt/m ² (depending on fabric)
MasterBrace 4000	Epoxy adhesive for MasterBrace laminates & bar/rod	3.33L ~ 10 m of laminate @3 mm thick

Repairs: Any repairs to the substrate and surface preparation required, shall be done to the satisfaction of the specifying consulting engineer and/or MB Solutions Australia Ltd.

MasterEmaco S 488Cl	High strength cementitious repair mortar
MasterProtect 150/160	UV resistant topcoat
MasterEmaco 2525 MasterBrace 1444 MasterBrace 1446	High build Epoxy adhesive and binders
MasterInject 131l	Low viscosity Crack injection

Application Requirements: All work shall be carried out by adequately trained and skilled sub-contractors, under appropriate supervision.

Safety: Always ensure the appropriate use of adequate PPE (gloves, goggles, long sleeves etc) and comply with all other safety related requirements when applying MasterBrace materials.

Quality Systems: The applicator shall operate under a fully compliant quality system, to ensure the on-site quality of applied material. The applicator shall keep fully documented work records for all works undertaken.

Quality Control: If after application and/or testing, any applied material is deemed as unsatisfactory by the specifying consulting engineer and/or MB Solutions Australia Ltd, it may need to be rectified at the applicator's cost.

Weather: No product application work is to be carried out in temperatures below 5°C or above 35°C, unless special precautions are taken.

Continuity of Process: All applications shall be done in continuous operations, including first primer coat, through to last layer of FRP, without significant delay.

Part A - Preparation

AI. Concrete Substrate

A load-bearing substrate is a pre-requisite for the reinforcement with all FRP systems. All concrete substrate shall be of at least 28 days old. A tensile bond strength of the substrate of > 1.5 MPa is required. Testing of the substrate shall be performed as required utilizing the testing procedure indicated in Appendix A, "General Description of Tensile Pull-Off Test" document. This should be tested prior to work proceeding and to verify the contractor's chosen preparation procedures.

All cement laitance must be removed prior to application. The surface layer of the concrete shall be removed to expose small particles of sound aggregate such that the minimum roughness or surface profile to be achieved is CSP 3, as per ICRI (International Concrete Repair Institute) Technical Guideline No. 310.2R-2013. The optimum mean surface roughness or profile is 0.5 – 1.0 mm, and must expose soundly bonded aggregate with a surface presenting similar to 60-grit sandpaper.

The surface shall not be roughened excessively, or in a manner that will create unnecessary damage to the substrate concrete. Ideal surface preparation methods are grit blasting, shot-peening or grinding. Any additional water must be avoided. Dirt, oil, grease and other contaminants must be removed. Immediately prior to the application of the FRP strengthening system including epoxy primer, levelling mortar and/or adhesive, the surface must be cleaned with a brush or a vacuum cleaner to remove all loose particles and dust.

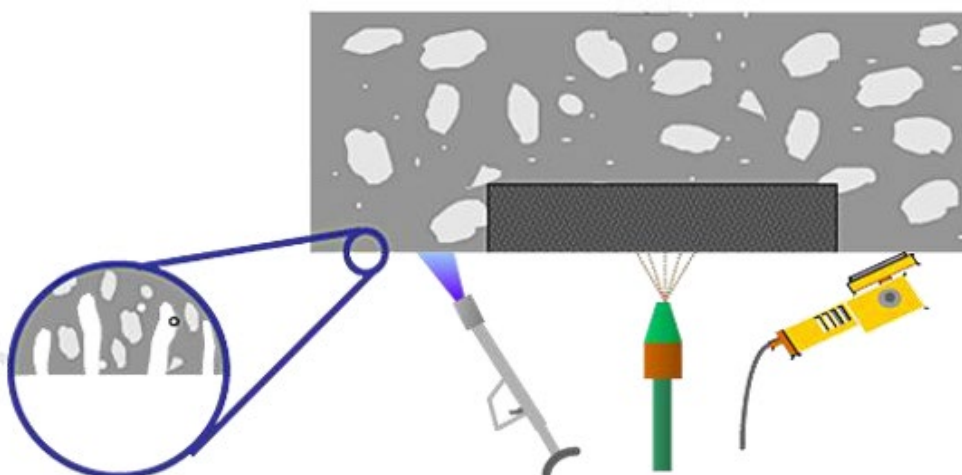
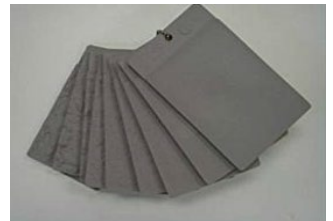

Cracks in the substrate concrete need to be assessed and treated depending on their location and movement characteristics. Cracks parallel to the laminate, generally need no special treatment. All cracks crossing the laminate shall be epoxy injected (high pressure type, using the SCBP system and resins, such as **MasterInject** product).

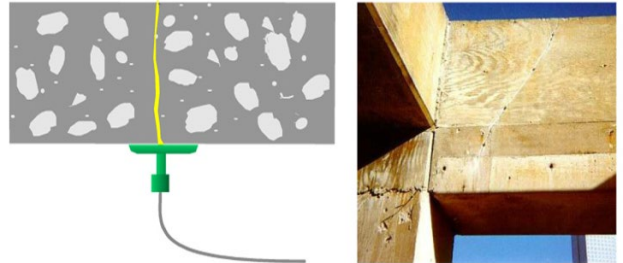

Immediately prior to application, remove all loose dust particles and adopt a visual inspection of the concrete surface.

Measure the moisture content of the concrete substrate. The moisture content of the concrete must be below 4% or its relative humidity less than 70% according to ASI 884-1995.

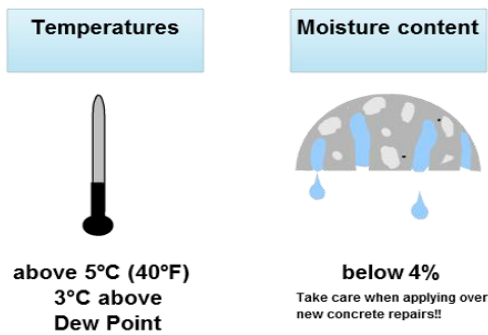

A2. Concrete Flatness

Generally, the FRP shall not be positioned on surfaces that, under load, reverse the curvature that the FRP originally forms on application. That is, for a FRP on the underside of a typical slab or beam, an upward substrate curvature (or hog) is generally unacceptable. A flat or downward substrate curvature (or sag) is required.

The flatness of the concrete substrate surface must be checked by means of a metal straight edge. The surface flatness shall not exceed 5 mm within a substrate length of 2 metres. Furthermore, the general flatness shall not exceed 1 mm in 300 mm for any length of FRP.

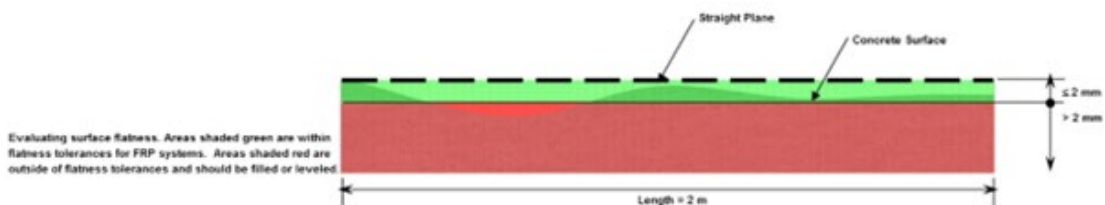

A3. Levelling of the Substrate

Where required, any voids must be levelled, by either grinding the surface flat, or building it up, with a levelling mortar. Local grinding of high points and removal of formwork edges etc is mandatory to achieve the required profile.

Generally, voids are levelled with an epoxy-based levelling mortar (like **MasterBrace 4000**) at least 1 day prior to the application of the laminate. Clean and then prime the surface with **MasterBrace P 3500** prior to application of the levelling mortar. Apply the levelling mortar while the primer is still tacky. If the primer is allowed to dry, the surface must be re-prepared and primed prior to any work proceeding.

- Round edges to 20-mm radius

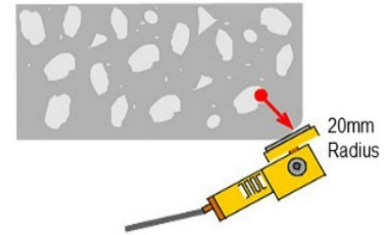

Prepare substrate surface to a clean, contaminant free, dry, open pored and textured to CSP 3-4 condition

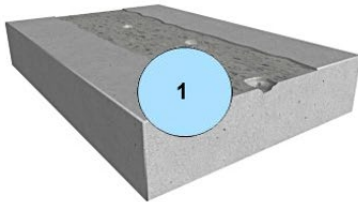

Prime surface with MasterBrace® Primer

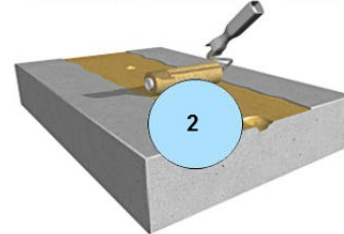

Localized surface preparation of concrete ready to receive MasterBrace®Laminate system

Fill any surface defects with MasterBrace® Putty if needed

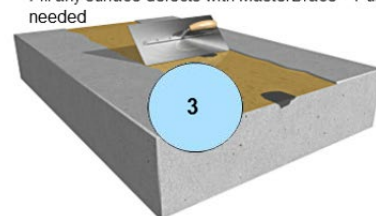

In extreme situations the levelling mortar can be bulked out with **F5** or **F30** filler 1/1 by volume to aid in deep fills, greater than 20 mm. The levelling mortar shall generally be left with a smooth yet open textured, level surface. If the FRP is applied in excess of 24 hrs after levelling, prepare the levelling surface by grinding with a belt sander or similar and wiping the surface with a solvent soaked rag (**MasterSeal 955**).

Alternatively, level voids by use of a cementitious based mortar (**MasterEmaco S5400 CI**). This must be placed at a minimum thickness of 10 mm and cured to a moisture content of <4% prior to application of the FRP material.

When FRP fabric is running perpendicular to an external corner and is to be wrapped around it, the concrete must be rounded to a radius of at least 12 mm. Internal corners must be smoothed by

forming a cove or chamfered detail. No special detailing is required if fabric material is running parallel to the corner.

A4. Environmental Conditions

The presence of moisture may inhibit adhesion of primer and/or resin. Do not apply FRP materials when rainfall or condensation is anticipated.

In general, for application of FRP systems, the ambient temperature must be at least 5°C and may not exceed 35°C. The temperature of the substrate concrete must be higher than 8°C.

Determination of dew point, air and substrate temperatures and of relative humidity of air, immediately prior to the application is required, if the substrate is exposed to the weather or is in an external environment. If the dew-point temperature differs by less than 30°C from the substrate temperature, the substrate must be warmed up, or the relative humidity of the air must be reduced. Application may proceed if “concrete temperature > Dew point + 3°C”.

Under some circumstances, dependant on substrate porosity and environmental factors, out-gassing of air may occur, producing small air-voids under a freshly laid sheet of fabric. If this occurs, pre-priming to seal the surface may be required, as well as application of the fabric on a “falling-thermometer”, to minimize the amount of out-gassing produced. Trialling of the appropriate procedures and tensile bond testing are recommended, prior to moving forward in this situation.

A5. Set-out

Careful set-out and masking of the edges 5 mm beyond the width of the FRP materials, can produce an aesthetic result.

A6. Near-Surface Mounted (NSM)

Under normal conditions, preparation of surfaces for NSM Bars, Laminates) and -sometimes- Anchors requires slots to be cut into the surface according to the depth and widths indicated on the table below. For laminates, the slot width shall be 6 mm wider and at least 6 mm deeper than the laminate, and orientate the laminate in a vertical direction. Check that no reinforcement or other structural elements will be cut or compromised and thoroughly clean the slot prior to application. Ensure moisture content as per clause A1.

FRP diameter or size (mm)	Slot width (mm)	Slot Depth (mm)	Approx length of bar per 5 kg kit of MasterBrace 4000 adhesive
8 (Bar)	14	14	20 m
10 (Bar/Anchor)	16	16	16 m
12 (Bar)	18	18	13 m
16 (Bar)	22	22	10 m
LAM 15/2.5	8.5	21	24 m

Part B – General Application

B1. Working with Epoxy Resins

Do not dilute any epoxy resins used with the MasterBrace FRP systems with solvent.

After any resin has been mixed with hardener, the mixed resin batch must be used within its pot-life. This sometimes referred to as open-time or batch-life. The mixed batch of resin must not be used after expiration of its pot-life, as the adhesion may be affected. In the case of MasterBrace 4500 saturant, an increased resin viscosity will prevent proper impregnation of the FRP fabric materials.

B2. Priming with MasterBrace P 3500

Research has indicated that long term bond strengths to the substrate, especially in wet-dry cycles, will be improved by priming with MasterBrace P 3500.

To comply with AS 5100.8 requirements; priming shall be applied in all FRP applications for laminate, bar and fabric systems, unless directed otherwise.

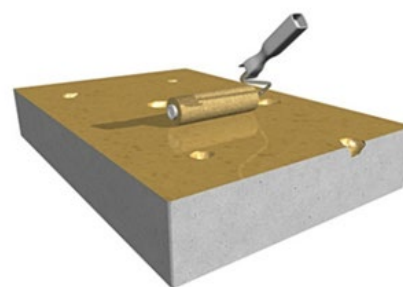

Always apply the next layer of FRP resins onto the primer, whilst it is still tacky. If the primer is allowed to dry, the surface must be re prepared and primed prior to any work proceeding.

When required, grind the hardened primer to give a roughened surface and solvent wipe using MasterSeal 955, allowing the solvent to completely flash off.

DO NOT DILUTE PRIMER OR RESIN WITH SOLVENT. After the resin has been mixed with hardener, the mixed resin batch must be used within its batch-life. The mixed batch resin must not be used after expiration of its batch-life as increased resin viscosity will prevent proper impregnation of the FRP fabric materials.

Part C - MasterBrace Laminate (and MBar)

CI. Handling

- Handle with care: MasterBrace Laminate carbon plates can be fragile if improperly handled. Manual handling should always be with protective gloves to prevent harm from carbon splinters.
- Delivery: MasterBrace Laminate are normally delivered to site in two ways. Both packaging methods, may be handled with a fork-lift on site:
 - In rolls that are packaged into cardboard boxes, loaded on pallets



- In pre-cut lengths, packaged in wooden crates.



- Storage: MasterBrace Laminate requires protection against heat, sun and weather.
- They must be stored on a solid, flat and dry surface, inside a ventilated shelter. If stored in the open, protect with opaque waterproof covers. Rolls must be stored only in the horizontal position.
- Minimum Roll diameter: MasterBrace Laminate rolls are delivered with a specific roll diameter (800 mm in most cases). This specific diameter is the minimum diameter. In case of re-rolling, the minimum diameter must never be reduced.
- Unpacking of rolls: All **MasterBrace Laminate** that are delivered in rolls, are provided with plastic straps. Unrolling should be completed by at least 2 persons. While one maintains the roll in position, the second cuts the plastic straps one by one. The beginning and end on unrolling are the 2 critical phases of unpacking a roll. Alternatively, a simple roller frame may be used to help hold the **MasterBrace Laminate** in position (refer photos below).



- Cutting: **MasterBrace Laminate** plates should be cut with diamond coated tools. The cutting speed should be between 20 and 80m/s. Protection against dust is required. A guillotine saw of proper size (refer photo below) as well as a metallic hand saw are acceptable alternative solutions.



- Drilling: Do not drill **MasterBrace Laminate**, otherwise the mechanical properties will be altered.
- Peel-ply: Most of the **MasterBrace Laminate** are delivered with 2 peel-ply, one on each side of the laminate, which must be removed before bonding.

C2. Application of MasterBrace Laminate (summary)

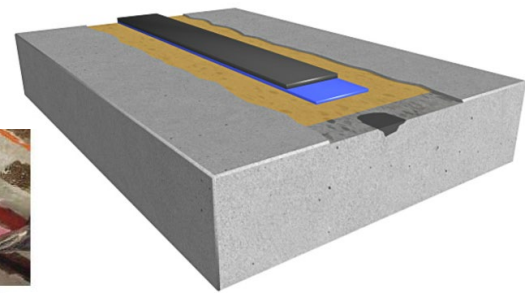

1 Apply MBrace Primer onto prepared concrete substrate (optional)



2 Level prepared concrete substrate with MBrace Putty / Levelling Mortar (optional)



3 Apply MBrace Laminate Adhesive to substrate



4 Remove Peel-Ply from laminate. The easiest way to take off the peel-ply is with a cutter/Stanley knife. Start to lift the peel-ply with the knife (start from the corner as it will be the easiest spot) and move the knife across the sheet. Once the peel-ply has started to lift, pull back by hand the required length of the Laminate.



5 Apply MBrace Laminate Adhesive to Laminate



6 Position MBrace Laminate and apply to substrate



7 Roll MBrace Laminate to secure onto substrate and clean up excess



8 Apply MBrace Topcoat (optional)

C3. Preparation of MasterBrace Laminates (and MBar)

The range of **MasterBrace Laminates** (and **MBar**) come supplied with either protective plastic peel-ply layers (on both sides of the Laminate or wrapped completely around the bar) or as a plain section (with a rougher, matt surface on the one side and smoother, glossy surface on the other).

a) For Laminates (and MBar) supplied with peel-ply:

Once the peel-ply is removed, either side may be used to bond, as the surface has a slightly textured roughness on both sides. Decide which surface you intend to bond to the concrete (or previous Laminate) as this is the surface to which you will apply adhesive. Simply remove the peel-ply from this surface using the following procedure and as per Appendix C:

1. Take a sharp cutting blade and scrape along the width of the laminate, until the peel ply starts to come loose.
2. Working from one corner, lift the peel-ply with the help of the cutter.
3. Using the cutter by running the blade under the peel-ply, lift a small section of the ply, across the whole width of the laminate.
4. When you can grip the peel-ply, gently remove it, pulling at a 45° angle, along the full length of laminate to reveal the clean laminate ready for adhesion. There is no need to use solvent to clean the laminate, unless it gets contaminated.
5. At this stage, it is not necessary to remove the peel-ply from the other side of the laminate. This peel-ply may be left in place, but must be removed prior to painting or subsequent layers of laminate going over.

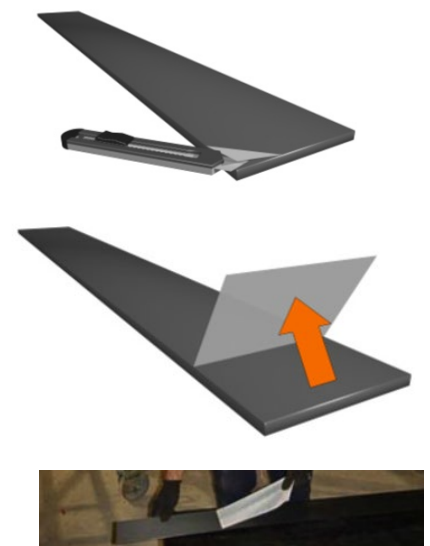

b) For plain Laminates (and MBar), without peel-ply:

The adhesive must be placed on the rougher, matt side of the laminate (sometimes this surface has no marking on it). Thoroughly clean this side first using a white rag soaked in a solvent-based cleaner (**MasterSeal 955**), in order to remove carbon dust and other contaminants. Cleaning must be repeated until the white rag remains free of black carbon dust and the surface is clean of all contaminants.

When cutting the plain type FRP laminate to length, wrap the laminate with masking tape prior to cutting with an angle grinder or similar. Mount laminate securely during this operation to prevent longitudinal splitting.

c) Placing multiple plies (layers) of Laminates.

Normally there is a maximum of two plies (layers) of Laminates placed on one another. When placing multiple plies (layers) of Laminate, ensure the following conditions are satisfied, prior to the placement of adhesive onto the first layer of Laminate:

For Laminates supplied with peel-ply:

Remove the peel-ply from the face of the first Laminate, exposing the rough surface and apply a layer of adhesive to the clean surface. Apply adhesive to the second layer of Laminate in accordance with the instructions A) above, and bring the two together and squeeze out the excess adhesive.



For plain Laminates, without peel-ply:

The smooth glossy surface must be carefully sanded to remove the gloss, taking care to not damage the carbon fibres contained within the first Laminate. Once sanded, completely clean the surface with a solvent soaked rag and allow to dry. Apply a layer of adhesive to the clean surface. Apply the second layer of Laminate in accordance with the instructions A) or B) above, depending upon the type of Laminate used for the second layer.

d) Preparation of Laminates, prior to subsequent materials (eg protective coatings, other FRP fabric, toppings etc)

For Laminates supplied with peel-ply:

Remove the peel-ply from the face of the first Laminate, exposing the rough surface. Apply the subsequent layer of material to the clean surface, according to the relevant instructions. Note that this may involve the use of a primer.

Clean, roughened texture revealed after
peel-ply is removed

Ideal for providing optimum bond strength



For plain Laminates, without peel-ply:

The smooth glossy surface must be carefully sanded to remove the gloss, taking care to not damage the carbon fibres contained within the first Laminate. Once sanded, completely clean the surface with a solvent soaked rag and allow to dry. Apply the subsequent layer of material to the clean surface, according to the relevant instructions. Note that this may involve the use of a primer.

C4. Application of MasterBrace 4000 adhesive

The instructions of the technical data sheet must be followed. In particular, mixing of full kits, correctly proportioned and by a mixing drill with an appropriate paddle, for at least 3 minutes, is required.

MasterBrace 4000 adhesive is generally applied onto both the concrete surface and the back of the laminate, to minimise the air voids in the final adhesive layer.

The homogeneously mixed epoxy adhesive (**MasterBrace 4000**) is applied to the tacky primed concrete surface by means of a notched steel trowel or similar.

In the application area of the laminate, the concrete surface shall be completely covered with adhesive to a nominal thickness of between 1-2 mm.

The cleaned and fully dried FRP laminate is then coated in a "V" profile with the **MasterBrace 4000** by means of a purpose made dispenser box/jig or trowel to give a nominal thickness of 2 mm in the middle of the laminate tapering to 1 mm at the edges.

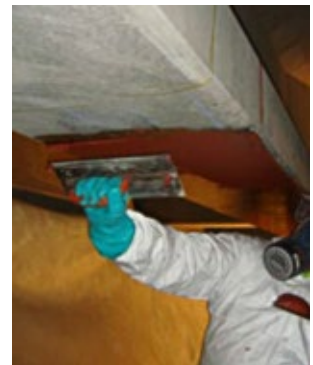
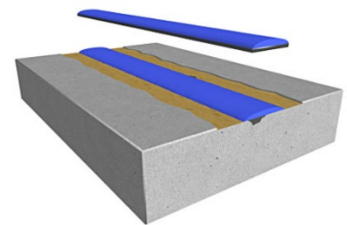

C5. Application of the MasterBrace Laminate

Lightly press the FRP Laminate with the fingers onto the prepared application area. The FRP Laminate is then pressed on with a hard rubber roller until the fresh adhesive exudes from both sides of the laminate. Roll the laminate first in the centre of the strip and then roll each edge. This guarantees that no significant voids exist between the laminate and the substrate surface.

The excess adhesive can be removed by means of a spatula. The mean layer thickness of the final adhesive should be 2mm (min. 1mm – max. 3mm).

If desired, adhesive residues on the laminate surface can be removed with **MasterSeal 955** solvent before hardening. Additional FRP Laminates can be applied in parallel at a minimum distance of 5mm.

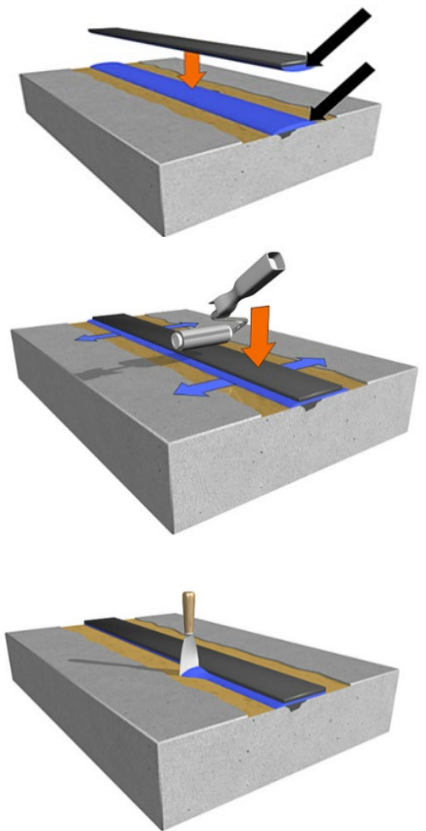

Due to the very high thixotropy of the **MasterBrace 4000**, no support devices are normally required. In certain cases however, some form of temporary fixing may be required. Examples of this include situations where the weight is excessive (eg wide and thick laminates > 1.4 mm) or where the laminate wants to straighten (eg where the substrate changes direction and the laminate has a slight bend in it).

During the application and until hardening of the adhesive (normally after 1-2 days), any vibration that could affect the application area must be avoided.



C6. Application of the MasterBrace MBar and Laminate

- a) Prepare the slots as per clause A6.
- b) Prime the slots with **MasterBrace P 3500** and whilst still tacky,
- c) Apply **MasterBrace 4000** to half fill the slot, via a caulking gun or similar, ensuring no air voids.
- d) Remove the peel ply
- e) Press the **MasterBrace MBar** or **Laminate** into the wet adhesive. If required, immediately apply more adhesive to ensure no air gap exists.

Tool over the surface flush with the surrounding substrate.

- f) Broadcast clean kiln-dried sand onto the wet adhesive surface (similar to clause D4 (i)), if required to assist bonding of subsequent coatings or layers.

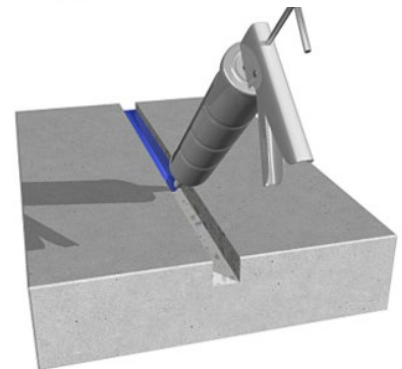
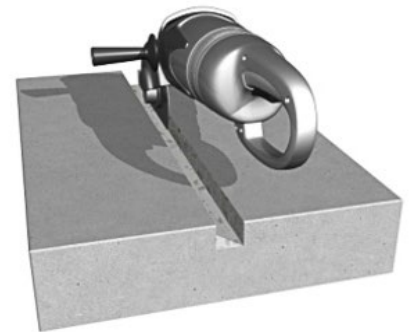

MasterBrace® NSM Bars are produced incorporating a protective peel ply layer which ensures the optimum clean surface for the best bond with the epoxy

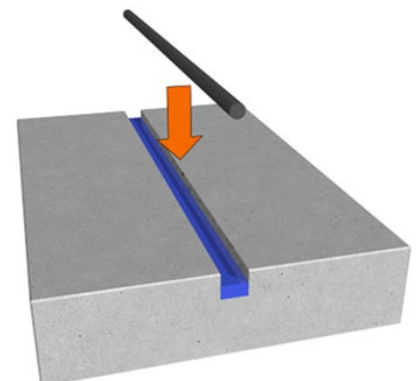
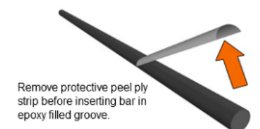

Part D – MasterBrace Fabric

DI. Handling

- Handle with care: **MasterBrace Fabric** can be fragile if improperly handled. Manual handling should always be with protective gloves.
- Delivery: **MasterBrace Fabric** is normally delivered to site in rolls, which are wrapped in plastic and contained within cardboard boxes, loaded onto pallets.



- Storage: **MasterBrace Fabric** requires protection against heat, sun and weather. It must be stored on a solid, flat and dry surface, inside a ventilated shelter. If stored in the open, protect with opaque waterproof covers. Rolls must be stored only in the horizontal position.
- Minimum Roll diameter: **MasterBrace Fibre** rolls are delivered with a specific roll diameter (150 mm in most cases). This specific diameter is the minimum diameter. In case of re-rolling, the minimum diameter must never be reduced.
- Unpacking of rolls: **MasterBrace Fibre** rolls may be delivered with a layer of plastic between successive layers of fibre. This shall be removed prior to bonding.
- Cutting: **MasterBrace Fibre** should be cut with good quality shears (scissors), designed to cut cleanly through the fibre.
- Drilling: Do not drill through **MasterBrace Fibre**, otherwise the mechanical properties will be altered.

D2. Application of MasterBrace Fabric (summary)

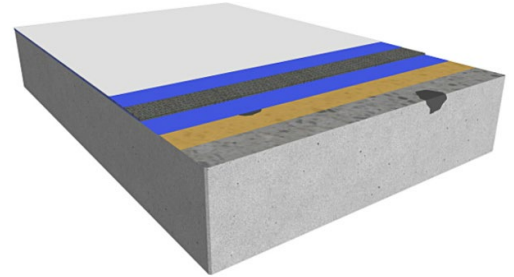

1 Apply MBrace Primer onto prepared concrete substrate (optional)

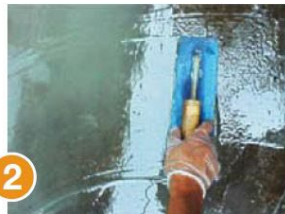

2 Level prepared concrete substrate with MBrace Putty / Levelling Mortar (optional)



3 Apply first coat of MBrace Saturant



4 Apply MBrace Fibre Reinforcement



5 Apply second coat of MBrace Saturant



6 Apply MBrace Topcoat (optional)

access allows.

When multiple lengths of fabric materials are adhered to a concrete surface, a minimum of 150 mm overlapping length must be applied in the longitudinal fibre direction, unless otherwise noted. No overlapping is required in the lateral direction.



D4. Application of MasterBrace Fabric

a) Apply a coat of **MasterBrace 4500** (saturant) to the primed surface using a medium nap roller (approx. 10 mm) to approximately 500 - 750 microns wet film thickness (1.3-2 m² per litre) or sufficient to achieve a wet-out of the FRP Fabric. This value will vary depending on the weight of the FRP Fabric used (in gm/m²) as well as the ambient conditions and wastage. A trial on site prior to full application is advisable to establish actual usage rates and to ensure complete wet out of the FRP fabric.

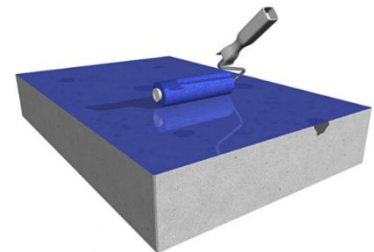

b) The **MasterBrace FRP Fabric** is placed fibre side down onto the concrete surface. Always work in the direction of the fibres and work from the centre of the length of the sheet to the ends, to remove any entrapped air. After smoothing down by hand, a squeegee or hard roller may be used, over the outside surface (or backing plastic/paper if supplied), to enhance the impregnation of the fabric material. If supplied, the backing plastic/paper is then peeled away. The surface of adhered fabric must be squeezed in the fibre longitudinal direction using a ribbed roller in order to impregnate resin into the fabric material and remove any air bubbles. Then go over the surface with a rubber squeegee/spatula to smooth out any remaining imperfections. Finally use a de-foaming roller to de-foam the resin coat if required.

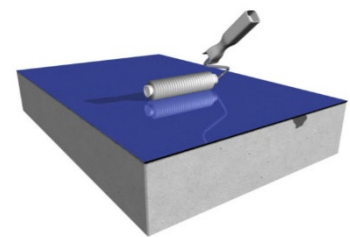
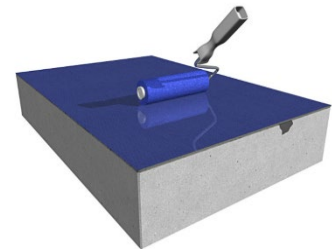
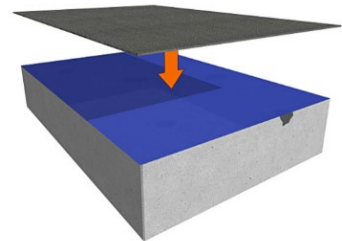

c) For joining strips of FRP Fabric Sheets in the fibre longitudinal direction, a 150 mm overlapping length is required. At the overlapping location, additional resin is applied to the

outer surface of the fabric layer to be overlapped. No lapping is required in the fibre lateral direction.

- d) Minimise the elapsed time between mixing and application of the **MasterBrace 4500** saturant to ensure the material is applied to the fabric at least 15 minutes prior to any thickening or gelling.



- e) Allow sufficient time between the application of FRP Fabric on the first coat of wet saturant and the application of the second coat of saturant. This is to allow for epoxy impregnation and is suggested at around ten minutes (depending on ambient conditions). Any lifting or delamination that may occur during this period, must be corrected by pressing down the FRP using a de-foaming roller or spatula.
- f) The second coat of **MasterBrace 4500** saturant must then be applied onto the surface of the FRP Fabric. Apply the next coat of saturant whilst the first coat is still wet to touch. The surface onto which resin has been applied must be applied in the FRP Fibre longitudinal direction. In order to impregnate and replenish resin into the FRP Fabric, use a medium nap roller and squeegee/spatula, with the same amount of saturant applied to achieve a wet film thickness as per the first coat above.
- g) In the case where more than one layer of FRP Fabric must be applied, the processes as detailed in items a) through f) must be repeated in a “wet-on-wet”, continuous process.

- h) In the case of outdoor applications, the work must be protected from rain, sand, dust, etc. by using protective sheeting and other barriers until fully cured. The curing rate of the adhered FRP is temperature dependent.
- i) If there is to be a top-coat application of a UV-stable acrylic paint (**MasterProtect I 50/I 60**), provide a sand-seeding, broadcast onto the still-wet, last layer of saturant applied to the MasterBrace Fabric. Prior to applying the acrylic top-coat, remove any loose sand from the surface. The acrylic top-coat may be applied after a minimum of 48 hours curing of the last coat of saturant.



D5. Repair of MasterBrace Fabric

This repair technique shall be used to repair large areas of damage to MasterBrace Fabric systems, in accordance with Clause E2. In this section, the material referred to as “putty” could be MasterBrace 1444 or MasterBrace 4000.

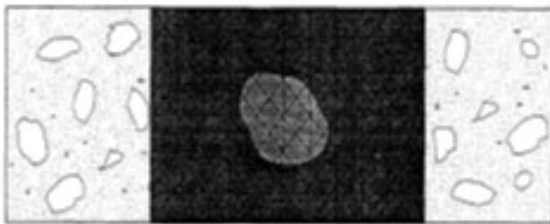

Step 1

- Identify delaminated/unimpregnated/damaged area by tap testing/tensile testing.

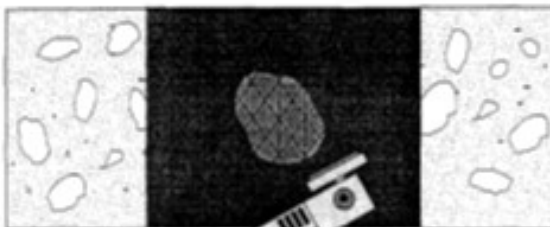

Step 2

- Sawcut/grind perimeter of damaged area and remove composite material.

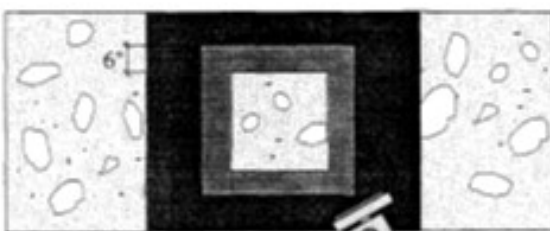

Step 3

- Lightly sand-grind composite repair lap area.
- Minimum repair lap = 6 inches.

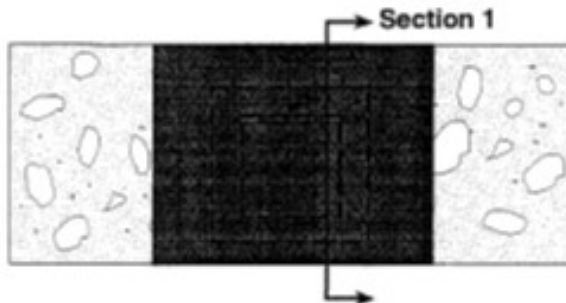

Section 1

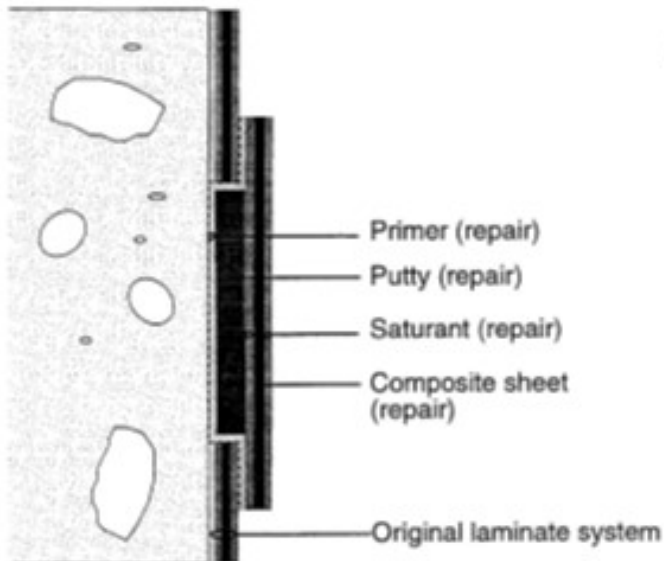

Step 4

- Apply primer.
- Apply putty (as required).
- Apply saturant & composite sheet per application instructions.

Notes:

- 1 Fiber orientation must be in same direction as base composite material.
- 2 For multi-directional applications, the first layer of composite sheet material should match the orientation of the first layer of base composite material. Additional layers of composite sheet repair should be applied in the same orientation as additional layers of base composite material.

Part E – MasterBrace Anchor

E1. Handling

- Handle with care: **MasterBrace Anchor** can be fragile if improperly handled. Manual handling should always be with protective gloves.
- Delivery: **MasterBrace Anchor** is normally delivered to site in cardboard Boxes.
- Storage: **MasterBrace Anchor** requires protection against heat, sun and weather. It must be stored on a solid, flat and dry surface, inside a ventilated shelter. If stored in the open, protect with opaque waterproof covers. Rolls must be stored only in the horizontal position.

E2. Application of MasterBrace Anchor

- a) **MasterBrace Anchor** can be installed either into a hole drilled into the substrate, or into a NSM slotscut into the surface of the substrate (refer to clause A6 of this document) .
- b) To install the **MasterBrace Anchor**, it's necessary to create a hole with a min. 16 mm diameter and a length of the pultruded part (normally min 150mm), unless otherwise specified by the engineer. Depending on the installation type, the hole can also be extended through the substrate.
- c) To prevent any damage to the Anchor's fibers during installation, it's important to round the edges of the hole to a 10mm radius.
- d) When the Anchor is installed through the substrate rather than inserted from one side, the hole must be drilled from both sides. Ensuring the hole's straightness is of utmost importance in this case.
- e) The drilled hole should be thoroughly cleaned to eliminate all traces of dust and loose particles. To achieve this, make use of the blow-out tool and the round brush, alternating between the two tools at least three times.
- f) On the substrate's surface, make eight star-shaped cuts. These cuts should be at least 8-10 mm wide and 5-10 mm deep. Once the cuts are made, it's crucial to remove any dust or residue using pressurized air or a vacuum cleaner.
- g) Apply **MasterBrace P 3500** primer to the prepared cuts and inside the hole and once still tacky:
- h) Apply a coat of **MasterBrace 4500** (saturant) to the primed surface and then fill the hole drilled in the substrate with saturant from the bottom up, using an adhesive gun. If the hole goes through the substrate and to avoid excessive waste of the resin adhesive, the hole can be only partially filled, leaving the “back end”, where the Anchors exits, empty, as resin will be pushed into this area when the Anchor is inserted from the other side, and the hole will still be filled completely. Air enclosures must be avoided.
- i) Insert the dry (pultruded) part of **MasterBrace Anchor** into the hole.

- a) Split the fiber part into the cuts and impregnate them with **MasterBrace 4500** until completely saturated and push them into the cuts.
- b) Fills the cuts with **MasterBrace I444** to level the surface.
- c) Install other **MasterBrace** composite (Fabric or Laminate) on top of the Anchor as described in the relevant parts.

Part F – Other Considerations

FI. Quality Control

After allowing at least 24 hours for initial resin cure to occur, perform a visual and acoustic tap test inspection of the layered surface. Test all the areas where FRP is applied to check for voids, bubbles and delaminations. Repair all voids, bubbles and delaminations by approved methods as per the requirements of the specification and to MB Solutions Australia Ltd's satisfaction.

In addition, the evenness of the FRP surface shall be checked. Deviations within a test length of 300mm may not exceed 1mm. If the test length measures over 2m, the maximum deviation is 5mm.

Direct pull-off tests shall be conducted to verify the tensile bond between the FRP material and the concrete substrate. For further information, refer to Appendix A, "General Description of Tensile Pull-Off Test".

- a) Unless otherwise directed by the project specification, perform a minimum of one pull-off test per 100 m of laminate length or one test per 10 m² of fabric (or a minimum of two per project), to surfaces strengthened with the FRP materials. The test is to be completed prior to the application of finishes on the FRP materials.
- b) An average of 1.5 MPa minimum shall be obtained from these adhesion tests. Inspect the failure surface of the core specimen to ensure that failure is in the concrete substrate. Failure at the bond line at tensile stress below 1.35 MPa is not acceptable.

F2. Repair Techniques

When required, repair of defective works within **MasterBrace FRP** systems may be done by a number of means. The choice will depend on the size and location of defect and the FRP system being used. Repair systems may include:

- a) Small delaminations, less than 25 mm x 25 mm and which are isolated (maximum two (2) defects in a 300 mm x 300 mm area), do not normally require any corrective action. If the size or number of defects is greater than this, corrective action will need to be taken as per below or as otherwise directed.
- b) Corrective Action may consist of two general methods:
 - i. Injection of resin into voids.

This process involves the careful filling, by injection of **MasterBrace P 3500**, into the voids, without causing more damage than exists in the void. The techniques will vary but may include the use of a large needle arrangement, with an inlet and outlet hole, to ensure that any air can escape. Always aim to minimize any damage to the FRP.
 - ii. Cut-out and replacement of defective area.

This method is the preferred method for all repairs.
For extreme cases where option i) is not deemed appropriate, areas of large defects may be cut-out and replaced with new material. The repair procedures should be as per clause D4. In this document, the material referred to as “putty” could be **MasterBrace I 444** or **MasterBrace 4000**.

Repair of all the defective work after the minimum cure time for the FRP. Comply with material and procedural requirements defined in this document and any related specifications. Repair all defects in a manner that will restore the system to the designed level of quality. Repair procedures for conditions that are not specifically addressed in this document or the specification, shall be approved by the Owner’s representative. All repairs and touch ups shall be made to the satisfaction of the Owner's representative.

F3. Heat Protection Measures

Since 2-component epoxy resins withstand temperatures of up to 70°C approximately, special attention may be required for heat protection measures (eg under fire exposure or with application of hot-mix asphalt). For application with hot mix asphalt, refer to Appendix B.

F4. Cold Weather Application/Accelerated Curing

For applications in cold weather or where accelerated curing is required due to time constraints, a number of methods are recommended.

- a) Pre-heat the adhesive at 250°C for 30 mins prior to mixing.
- b) After one hour of placement, maintain an ambient air temperature in the vicinity of the laminate not exceeding 500°C, for an additional hour (minimum). This is usually done by enclosing the structure and heating as required.
- c) Maintain heat in the laminate and adhesive directly, by covering with heating blankets or similar.

F5. Hot Weather Application

For applications in warm weather or where retarded curing is desirable, a number of methods are recommended.

- a) Pre-cool the adhesive in an air-conditioned (or chilled water) environment at 15-200°C for at least 8 hrs prior to mixing.
- b) Work during the cooler parts of the day and shade materials and application surfaces wherever possible.
- c) Minimize heat build up in the epoxy materials by mixing smaller portions and/or spreading mixed material out into smaller volumes prior to use. Discard any material that has changed consistency since first mixing.

This guideline will not cover every project requirement. Therefore a project specific method statement may be required for heat curing, application method, surface preparation, timing of application and hand over periods to mention a few.

Appendix A - General Description of Tensile Adhesion Test

The following is a description of a field test for concrete surface soundness and overlay bond in accordance with AS 1012.24 using 50 mm diameter aluminium dollies only, which have been modified to serve as the in-situ QA/QC test of the **MasterBrace Composite Strengthening System**. The tests are carried out on actual structural members strengthened with the composite FRP system. Although there are variations in the equipment for carrying out pull-off tests, the general procedure can be summarized as follows:

1. After the composite strengthening system has hardened, core drill through the composite material and down 3 – 6 mm into the concrete substrate by means of an electric drill fitted with a carbide-tipped or diamond core bit. The core bit should be of such size as to produce a core the same diameter as the testing dolly, and which will have the appearance of a small island of composite material. The normal size of the dolly is 50 mm diameter. Ensure that the drilling operation does not cause any detrimental effects on the system by using wet drill techniques to minimise heat exposure, and ensure it is perpendicular to the surface.
2. Prepare the top of the core surface to be tested. Preparation includes cleaning of the composite material surface, roughening it with sandpaper, and final cleaning of any dust.
3. Place an aluminum dolly onto the surface of the core with epoxy adhesive (**MasterEmaco 1444** or similar). The bottom surface of the dolly has to be sandblasted or sufficiently roughened with sandpaper, and be cleaned and free from any grease or dust. Mix the epoxy components according to the recommendations just prior to use. Apply a small amount of the mixed adhesive to the core surface and to the bonding (properly prepared) face of the dolly by spatula. Place the dolly on the core. In some cases, a disk is bonded to the composite surface prior to core drilling.
4. Allow epoxy adhesive to cure sufficiently (usually 24 hours or as required).
5. Attach a loading frame (Proseq or similar) to the dolly such that a load can be applied at right angles to the surface. A frame around the test area provides the reaction force to the load. Ensure that the attachment of the loading frame does not induce any lateral sideways force onto the dolly, either prior or during testing.
6. Zero the machine and increase the load until a specified level is reached or the specimen fails.

7. At failure, the maximum pull-force is registered and the pull-off tensile strength is calculated by dividing the force by the cross-sectional area of the core. The mode of failure shall be recorded i.e., within the concrete substrate, within the composite material, between substrate and composite material, between composite material and dolly, or any combination of the above.
8. Pull-off tests shall be carried out on each selected area. The average of the values shall be taken as a pull-off strength result.
9. Unless otherwise indicated by project specification requirements, most composite strengthening applications require minimum tensile strengths of the substrate of:
 - a) 1.0 MPa for fibre fabric sheet material systems.
 - b) 1.5 MPa for laminate material systems.

- ASTM D 7522 Direct tension Pull-off Test
- Provides vital information regarding the quality of a particular installation
 - Surface preparation
 - Correct mixing of epoxy systems
 - Measure bond strength to substrate and
 - Tensile strength of substrate when failure is, as it should be, in substrate itself

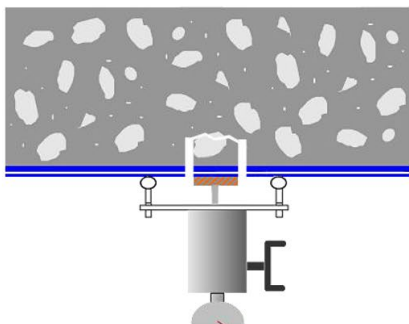

Direct tension loading device



Steel dollies after testing. The rightmost dolly fails and shows insufficient bond. The leftmost dolly passes showing failure in the concrete substrate



More tensile pull off tests showing complete break in concrete substrate. These tests are performed on a sacrificial test piece of FRP laminate



Appendix B - Application of Hot Mix Asphalt

When applying FRP materials and the intention is to overlay with hot-mix asphalt, the following general guidelines need to be addressed. Specific details need to be considered for each particular application, with reference to MB Solutions Australia Ltd once all parameters are known.

1. The temperature of the hot-mix shall be limited whenever possible, to the lowest practical temperature. Generally, temperatures shall not exceed 150° C, at the point of discharge.
2. The FRP materials shall be protected from this temporary temperature rise by one of two methods:
 - a) Near-Surface Mounted (NSM) FRP – As per clause A6, either turn the laminate strip on edge and insert vertically into saw-cuts, pre-cut into the concrete substrate or use FRP Bar installed in pre-cut grooves. Allow for an additional 5 mm depth of cut/groove and place the FRP material within 3 mm of the base concrete. Fill the remainder of the cut/groove with epoxy adhesive and broadcast F5 sand onto the surface of the wet epoxy adhesive.
 - b) Surface mounted (SM) FRP - Provide a protective mortar layer of minimum thickness 20 mm on top of the laminate, extending no less than 50 mm beyond the laminate edge, as per the following procedures:
 - i. Apply the FRP Laminate as per normal practices.
 - ii(a) Remove the protective peel-ply from the laminate surface or
 - ii(b) Lightly sand the top of the laminate without damaging the fibres and solvent wipe to remove any dust.
 - iii. Apply a thin layer of **MasterEmaco 2525** as a primer for the protective mortar layer.
 - iv. Apply a protective mortar layer of **MasterEmaco T920 CI** (or **MasterEmaco S5400 CI**) to the wet primer, to a minimum thickness of 20 mm.
 - v. Apply hot mix asphalt over entire surface no sooner than 7 days after application of mortar layer.

Appendix C - Procedure for removal of peel-ply

For carbon laminates supplied with a peel-ply, please follow the following removal procedure for successful application.

Equipment needed: Cutter blade, two hands and carbon laminate



Prepare the section to be removed:

1	2	3

Aim to loosen edge of peel-ply →



Lift the peel-ply with the edge of the cutter to start removal:

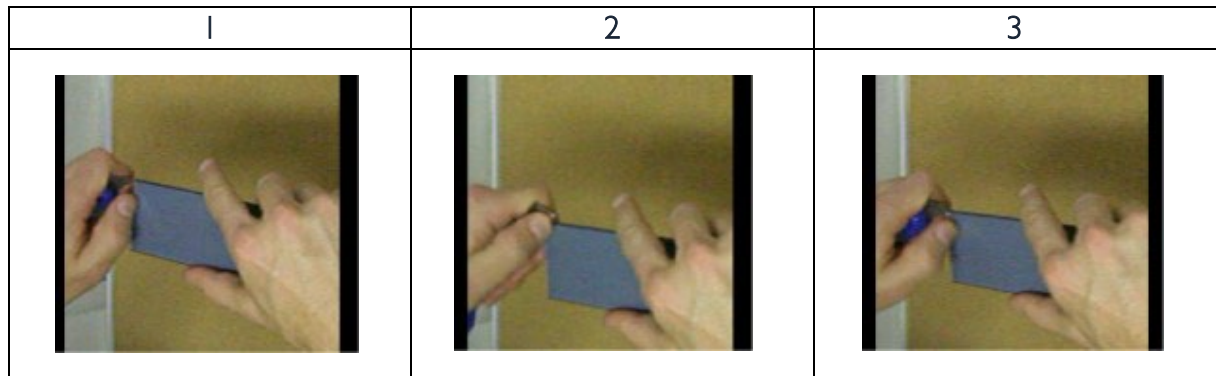

Get cutter blade under peel-ply

Tear off the peel-ply for the full width of the laminate:

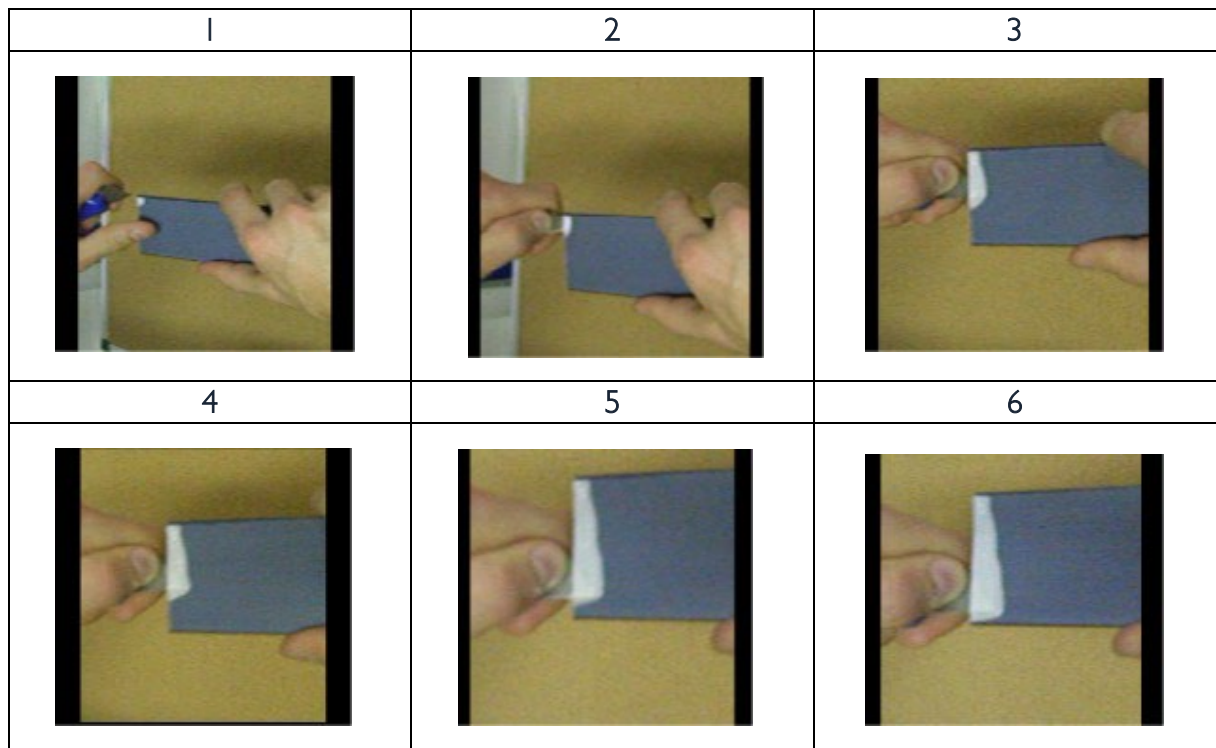

Aim to loosen edge of peel-ply →



Remove the full length of peel-ply on the required length of laminate. Pulling at a 45° angle may also assist with easy removal:



Until you get the clean laminate, without peel-ply.

Disclaimer

Application Guide for MasterBrace FRP V10 0225

STATEMENT OF RESPONSIBILITY

The technical information and application advice given in this MB Solutions Australia Pty Ltd publication are based on the present state of our best scientific and practical knowledge. As the information herein is of a general nature, no assumption can be made as to a product's suitability for a particular use or application and no warranty as to its accuracy, reliability or completeness either expressed or implied is given other than those required by law. The user is responsible for checking the suitability of products for their intended use and for ensuring that the application and use of the product is in accordance with the manufacturer's guidelines and recommendations.

NOTE

Field service where provided does not constitute supervisory responsibility. Suggestions made by MB Solutions Australia Pty Ltd either orally or in writing may be followed, modified or rejected by the owner, engineer or contractor since they, and not MB Solutions Australia Pty Ltd, are responsible for carrying out procedures appropriate to a specific application.

MB Solutions Australia Pty Ltd

ABN 69 634 934 419
 Suite 102, 2 Burbank Place
 Norwest NSW 2153

Freecall: 1300 227 300

www.master-builders-solutions.com/en-au

MB Solutions New Zealand Ltd

45C William Pickering Drive
 Albany, Auckland
 New Zealand

Phone: +64 9 414 7233

Emergency Advice:

1300 954 583 within Australia (24hr)
 0800 001 607 within New Zealand