

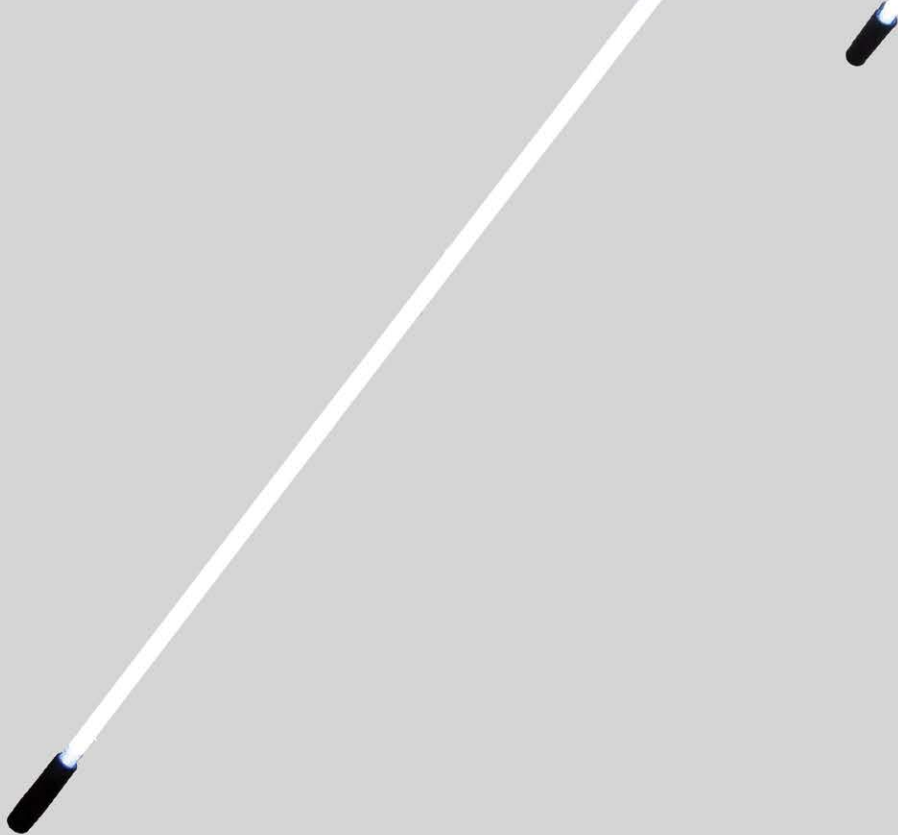

*Enter the Dragon*

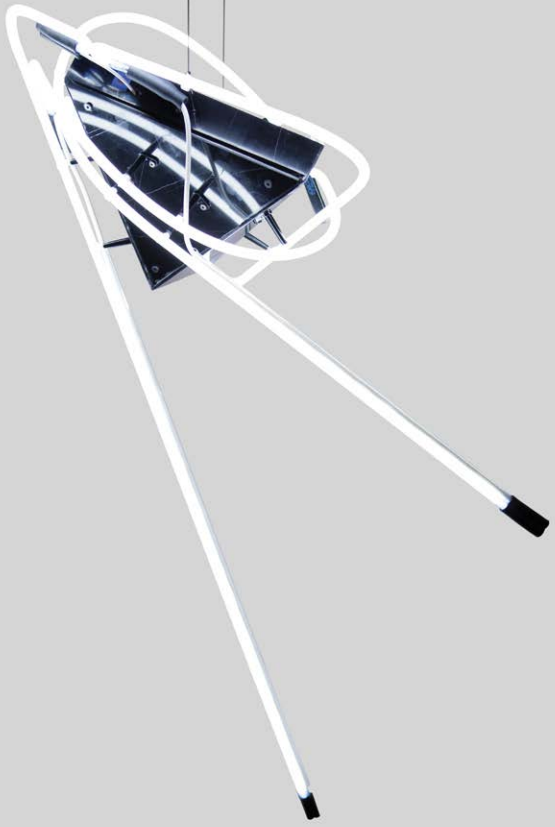

**BUREAU V**



*Enter the dragon consists of a black marble tetrahedral shape wrapped in warm white neon. The project operates as a collage of the formal and material tropes, as classic signifiers of wealth and power (the chandelier, the pyramid, and figured marble) are recontextualized, defaced, and framed by callow squiggles of a pop-commercial material.*

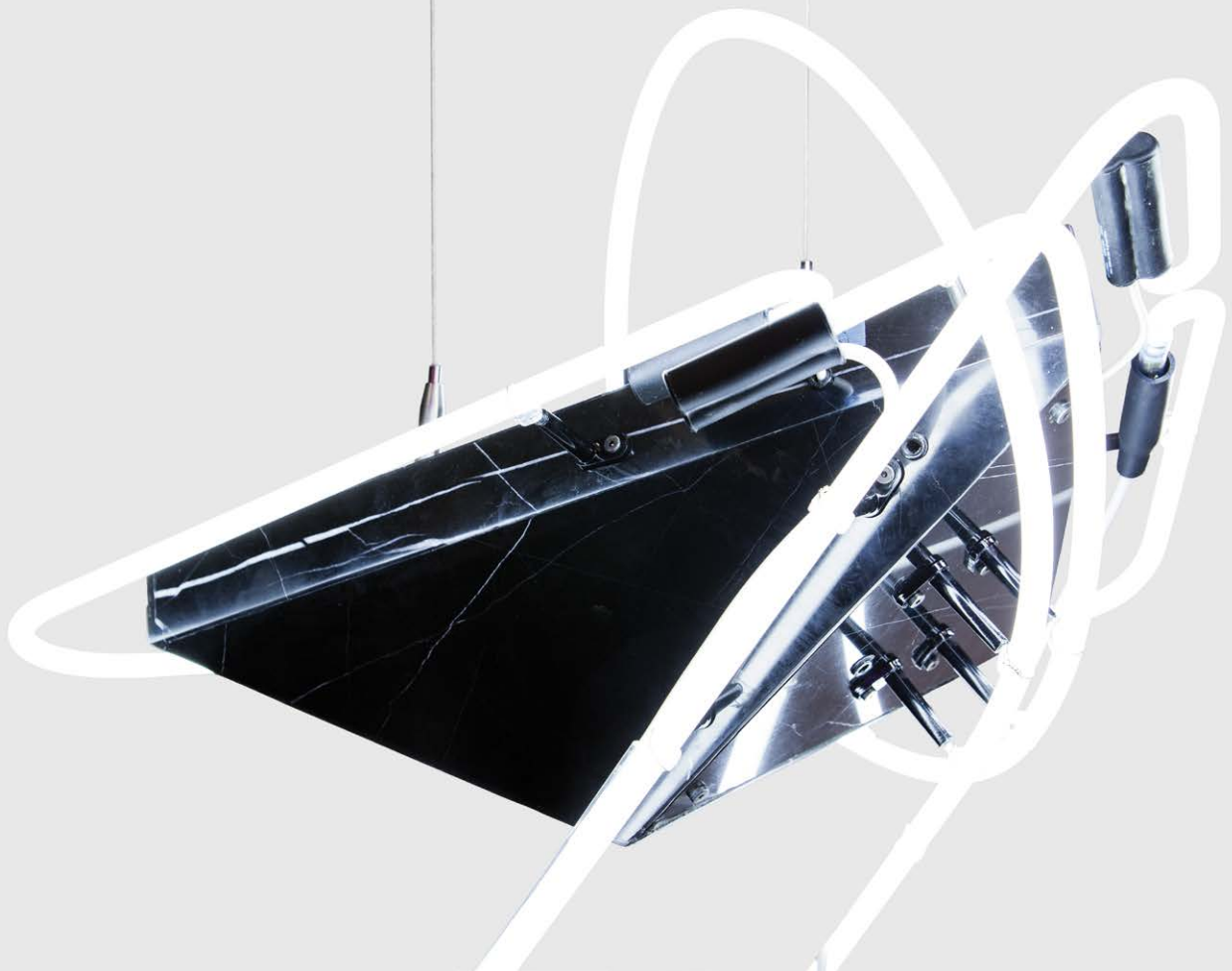

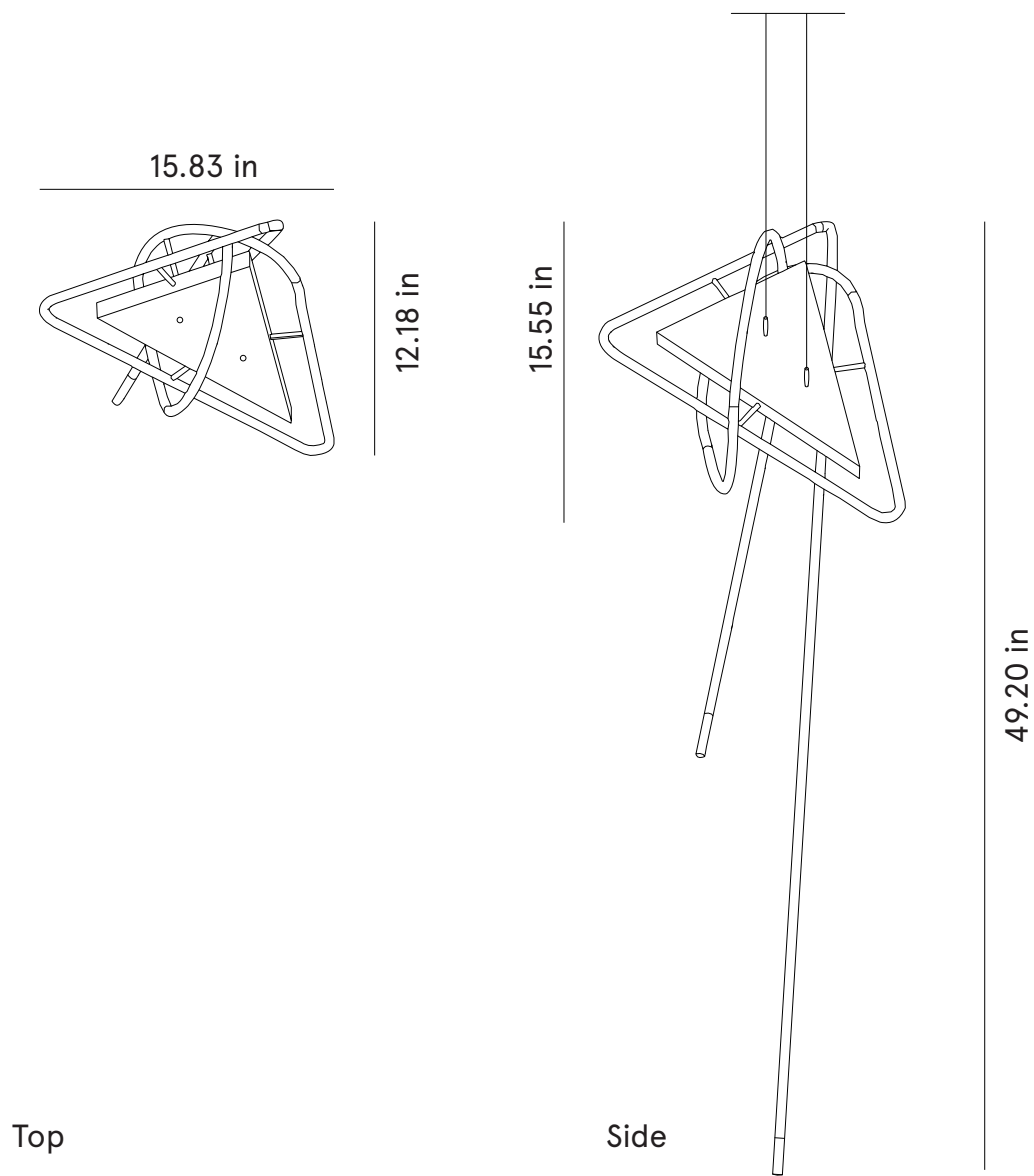

## *Materials*

*marble, neon, glass, steel*

---

## *Lamps*

*8mm cold cathode (neon) tubes, 3500 Kelvin white.*

*Aproximate light output: 3200 lumens*

*Power consumption: 150 watts*

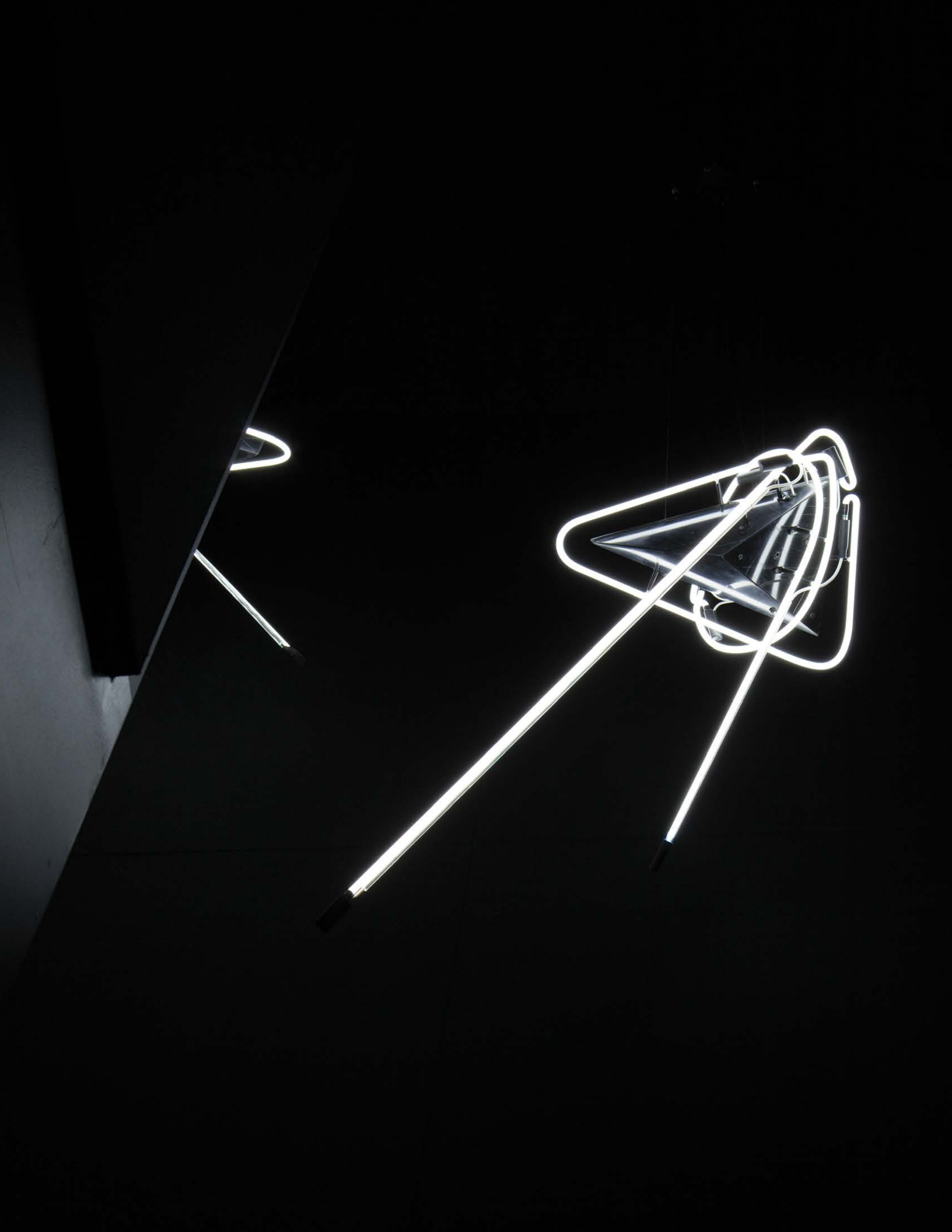



# **BUREAU V**