

## DIRECTIONALS

### CD3794 MegaFlex™ Series

#### Dual-Colour Flexible LED Light



Code 3's MegaFlex™ is a versatile exterior warning light that can be mounted on flat or curved surfaces up to 120° with self-adhesive, very high bond tape. Its 12 dual-colour LEDs provide exceptional output with combinations of amber, white, blue and red colours available. The light heads are protected in a clear, flexible silicone housing made from materials resistant to yellowing and warping. A two-bolt bezel is also included for easy installation on flat surfaces.

#### Models

PART NO.	LED COLOUR	VOLTAGE
CD3794BA		0.8
CD3794BW		0.8
CD3794RA		0.8
CD3794RB		0.8
CD3794RW		0.8
CD3794WM		0.8

#### Features and Benefits

- 12-24 VDC
- 69 flash patterns
- Flexible housing adapts to curved surfaces up to 120°
- Clear silicone lens material prevents yellowing or aging
- VHB tape mount to flat or curved surfaces
- 2-bolt mount with included bezel for flat surfaces
- Temperature range: -30°C to 50°C (-22°F to 122°F)

#### Bezel

2.7cm x 11.2cm

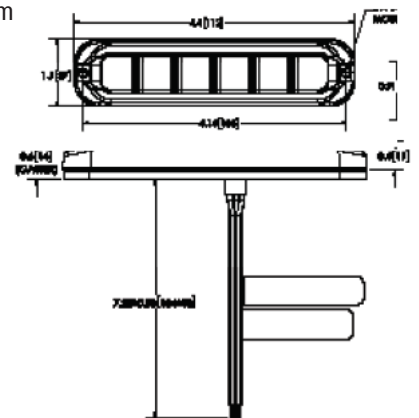

#### No Bezel

2.3cm x 10cm

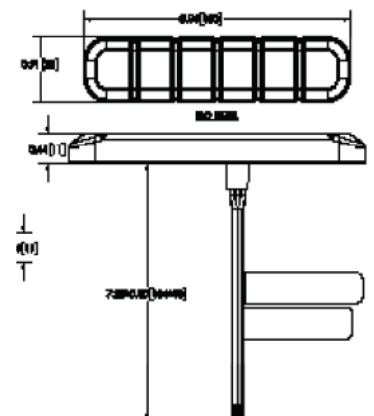

T: 1800 025 921 | E: esgapsales@esg.global