



BEACON CL199™ SERIES

Side & Top LED Lighting



CL199 Series beacons feature a clear polycarbonate lens with 12 LEDs and 12 auxiliary LEDs in the top that provide 360° vertical and horizontal coverage. CL199 beacons are waterproof, shock resistant, and meet a multitude of industry approvals. They are available in a wide range of colors, have 30 built-in flash patterns, and can be mounted with either a 3-bolt or magnetic mount. Available in 36 LED and 24 LED versions.

Specifications

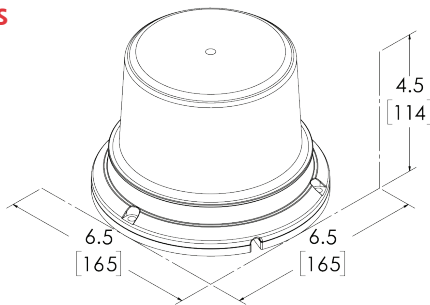

Features

- 12/24VDC, 1.2Amps
- Waterproof
- Shock resistant
- Auxiliary LEDs on top
- 30 flash patterns
- Temperature Range: -22°F to +122°F (-30°C to +50°C)

Models

MODEL	MOUNT	LENS COLOUR	LED COLOUR	MODEL	MOUNT	LENS COLOUR	LED COLOUR
CL199A	3 Bolt/1" Pipe	White	Orange	CL199RR-36	3 Bolt/1" Pipe	Red	Red
CL199A-36	3 Bolt/1" Pipe	White	Orange	CL199W	3 Bolt/1" Pipe	White	Orange
CL199AA	3 Bolt/1" Pipe	Orange	Orange	CL199MA	Magnetic	White	Orange
CL199AA-36	3 Bolt/1" Pipe	Orange	Orange	CL199MA-36	Magnetic	White	Orange
CL199B	3 Bolt/1" Pipe	White	Blue	CL199MAA	Magnetic	Orange	Orange
CL199B-36	3 Bolt/1" Pipe	White	Blue	CL199MAA-36	Magnetic	Orange	Orange
CL199BB	3 Bolt/1" Pipe	Blue	Blue	CL199MB	Magnetic	White	Blue
CL199BB-36	3 Bolt/1" Pipe	Blue	Blue	CL199MBB	Magnetic	Blue	Blue
CL199G	3 Bolt/1" Pipe	White	Green	CL199MG	Magnetic	Green	Green
CL199R	3 Bolt/1" Pipe	White	Red	CL199MR	Magnetic	Red	Red
CL199R-36	3 Bolt/1" Pipe	White	Red	CL199MRB	Magnetic	Red	Blue
CL199RR	3 Bolt/1" Pipe	Red	Red	CL199MRG	Magnetic	Red	Green

P: Emergency Services 1800 644 118 | E: ESGAPSales@eccogroup.com