

C5517 SERIES REFLEX® 17" LED MINIBAR

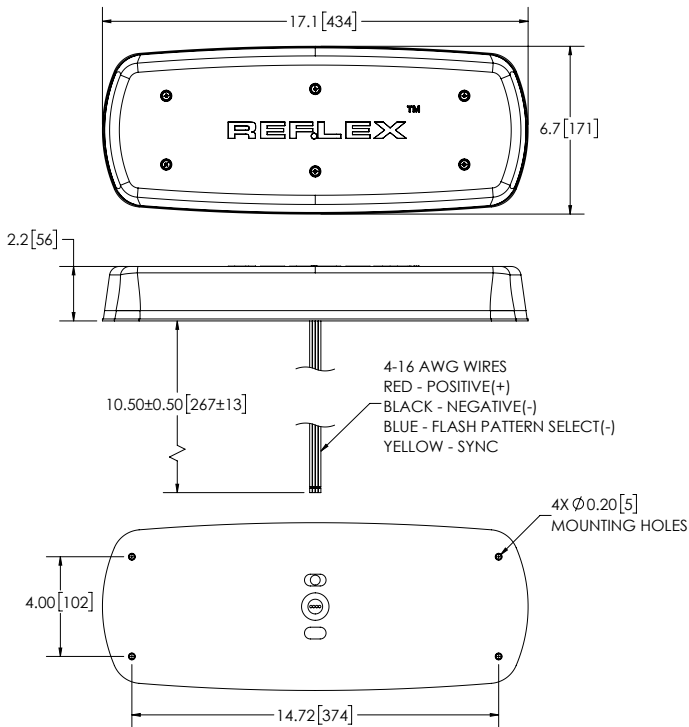

The C5517 Series 17" LED minibar is a compact and powerful warning solution with permanent, vacuum-magnet, and magnet mount options. This minibar, outfitted with 60 (single-color) and 180 (dual-color) high-intensity LEDs, provides full 360-degree lighting to attract the attention of drivers on the road. The C5517 Series 17" LED minibar features 37 single-color and 97 dual-color flash patterns, making it ideal for police, fire, or any other emergency vehicle application. Models with vacuum-magnet mounts include a cigarette plug switch with on/off and flash pattern control.



VOLTS AMPS	12-24V 6.2A
DIMS	2.5" H x 17.0" L x 7.0" D 64mm H x 432mm L x 178mm D
FLASH PATTERNS	37 Flash Patterns (single-color), 97 Flash Patterns (dual-color)
CERTS	CLASS I (SAE J845), CA T13, R10, R65, IP69K, RoHS, REACH
DETAILS	<ul style="list-style-type: none"> 60 LEDs (single-color) or 108 LEDs (dual-color) Sync-capable with existing line of Reflex® minibars Cigarette plug with on/off and flash pattern selection switch (vacuum-magnet only) Polycarbonate base and low-profile lens Temperature Range: -22°F to +122°F (-30°C to +50°C)
REPLACE	"_" with A = Amber, B = Blue, C = Clear, R = Red
ADD	Add "-VM" mounting extension to end of model for vacuum-magnet mount

MODEL	MOUNT	TYPE	LENS	ILLUMINATION COLORS
C5517AA	4 Bolt or VM	Single	A	A
C5517C_	4 Bolt or VM	Single	C	A, B, R
C5517CRB	4 Bolt or VM	Dual	C	RB



EZ5500BKT
Mounting Bracket