



Product Technical Specification

EM929X

Important Notice

Information relating to this product and the application or design described herein is believed to be reliable, however such information is provided as a guide only and Semtech assumes no liability for any errors in this document, or for the application or design described herein.

Semtech reserves the right to make changes to the product or this document at any time without notice. Buyers should obtain the latest relevant information before placing orders and should verify that such information is current and complete. Semtech warrants performance of its products to the specifications applicable at the time of sale, and all sales are made in accordance with Semtech's standard terms and conditions of sale.

SEMTECH PRODUCTS ARE NOT DESIGNED, INTENDED, AUTHORIZED OR WARRANTED TO BE SUITABLE FOR USE IN LIFE-SUPPORT APPLICATIONS, DEVICES OR SYSTEMS, OR IN NUCLEAR APPLICATIONS IN WHICH THE FAILURE COULD BE REASONABLY EXPECTED TO RESULT IN PERSONAL INJURY, LOSS OF LIFE OR SEVERE PROPERTY OR ENVIRONMENTAL DAMAGE. INCLUSION OF SEMTECH PRODUCTS IN SUCH APPLICATIONS IS UNDERSTOOD TO BE UNDERTAKEN SOLELY AT THE CUSTOMER'S OWN RISK. Should a customer purchase or use Semtech products for any such unauthorized application, the customer shall indemnify and hold Semtech and its officers, employees, subsidiaries, affiliates, and distributors harmless against all claims, costs damages and attorney fees which could arise.

The Semtech name and logo are registered trademarks of the Semtech Corporation. All other trademarks and trade names mentioned may be marks and names of Semtech or their respective companies. Semtech reserves the right to make changes to, or discontinue any products described in this document without further notice. Semtech makes no warranty, representation or guarantee, express or implied, regarding the suitability of its products for any particular purpose. All rights reserved.

Wireless Communications

Due to the nature of wireless communications, transmission and reception of data can never be guaranteed. Data may be delayed, corrupted (i.e., have errors) or be totally lost. The Semtech product should not be used in situations where failure to transmit or receive data could result in damage of any kind to the user or any other party, including but not limited to personal injury, death, or loss of property. Semtech accepts no responsibility for damages of any kind resulting from delays or errors in data transmitted or received using the Semtech product, or for failure of the Semtech product to transmit or receive such data.

Safety

Do not operate the Semtech product in areas where blasting is in progress, where explosive atmospheres may be present, near medical equipment, near life support equipment, or near any equipment which may be susceptible to any form of radio interference. In such areas, the Semtech product should be powered off.

Qualcomm licenses

Semtech's cellular modules are sold subject to certain notices and restrictions regarding patent licenses from Qualcomm Incorporated. These notices and restrictions are available at www.sierrawireless.com/qualcomm-notices.

Sierra Wireless

Semtech Corporation purchased Sierra Wireless in January 2023. The Sierra Wireless brand is gradually being phased out. During the phase-out period, references to both “Semtech” and “Sierra Wireless” may appear in product documentation.

Contact Information

Sales information and technical support, including warranty and returns	Web: sierrawireless.com/company/contact-us/ Global toll-free number: 1-877-687-7795 6:00 am to 5:00 pm PST
Corporate and product information	Web: sierrawireless.com

Revision History

For revision history details, see [Appendix H: Revision History](#) on page 100.

Contents

Important Notice	2
Wireless Communications	2
Safety	2
Qualcomm licenses	2
Sierra Wireless	3
Contact Information	3
1: Introduction	10
1.1 Supported RF bands	11
1.2 Mechanical Features	12
1.3 Host Interface Features	12
1.4 Modem Features	13
1.5 5G FR1 Features	13
1.6 LTE Features	14
1.7 WCDMA Features	14
1.8 Short Message Service (SMS) Features	15
1.9 Position Location (GNSS)	15
1.10 Accessories	15
1.11 Required Connectors	16
1.12 Integration Guidance	16
2: Electrical Specifications	17
2.1 M.2 (Host) Interface Pin Assignments	20
2.2 Power Supply	26
2.3 USB Interface	26
2.3.1 USB Host-side Recommendation	27
2.4 PCIe Interface	27
2.4.1 PCIe Host-side Recommendation	28
2.4.2 PCIE_PEWAKE_N	29
2.4.3 PCIE_PERST_N	29
2.5 SIM Interface	30
2.5.1 External SIM Interface Implementation	31
2.6 Control Interface (Signals)	32
2.6.1 WAKE_ON_WAN_N — Wake Host	33
2.6.2 W_DISABLE_N (WWAN Disable) and GPS_DISABLE_N (GNSS Disable)	34
2.6.3 Full_Card_Power_Off_N and RESET_N	35
2.6.4 PLA_S2_N (Power Loss Acknowledge)	36
2.6.5 WWAN_LED_N — LED Output	37
2.7 PCIE_DIS — Interface Selection	37
2.8 Tx Power Control	38

2.9 Antenna Control	38
2.10 Module Configuration	39
3: RF Specifications	40
3.1 Antenna Receptacles	40
3.1.1 5G NR Sub-6 GHz/LTE/WCDMA/GNSS Receptacles	40
3.2 RF Connections	42
3.2.1 5G NR Sub-6 GHz/GNSS Antennas and Cabling	42
3.2.1.1 Choosing the Correct 5G NR Sub-6 GHz/GNSS Antenna and Cabling	42
3.2.1.2 Determining the 5G NR Sub-6 GHz/GNSS Antenna's Location	43
3.2.1.3 Disabling the Diversity Antenna	43
3.3 Shielding	43
3.4 Ground Connection	43
3.5 Interference and Sensitivity	44
3.5.1 Interference from Other Wireless Devices	44
3.5.2 Host-generated RF Interference	44
3.5.3 Device-generated RF Interference	44
3.5.4 Methods to Mitigate Decreased Rx Performance	44
3.5.5 Radiated Spurious Emissions (RSE)	45
3.6 Radiated Sensitivity Measurement	45
3.6.1 Sensitivity vs. Frequency	45
3.7 Sounding Reference Signal	45
3.8 Supported RATs	46
3.8.1 Supported Bands	46
3.8.2 CA/EN-DC Support	50
3.9 Conducted Rx Sensitivity / Tx Power	50
3.10 GNSS Specifications	54
4: Power	55
4.1 Power Consumption	55
4.1.1 Peak Current Mitigation	58
4.2 Module Power States	59
4.2.1 Power State Transitions	59
4.3 Power Interface	61
4.3.1 Power Ramp-up	61
4.3.2 Timing	61
4.3.2.1 Power On/Off Timing for PCIe Interface	61
4.3.2.2 Power On/Off Timing for USB Interface	63
4.3.2.3 Reset Timing	63
4.3.2.4 Required Shutdown Sequence	63
4.3.3 Power Supply Noise	64
4.3.4 SED (Smart Error Detection)	64

5: Software	65
6: Mechanical and Environmental Specifications	66
6.1 Device Views	68
6.2 Product Marking (Labeling)	72
6.3 Electrostatic Discharge (ESD)	72
6.4 Thermal Considerations	73
6.5 Module Integration Testing	74
6.6 Secure Boot/Secure Debug	74
7: Regulatory Compliance and Industry Certifications	75
7.1 Regulatory Compliance	75
7.1.1 Important Compliance Information for Canada	75
7.1.2 Important Compliance Information for the United States	78
7.2 Industry Certifications	81
A: Antenna Specification	82
A.1 Recommended WWAN Antenna Specifications	82
A.2 Recommended GNSS Antenna Specifications	84
A.3 Sub-6 GHz Antenna Tests	84
B: Thermal Testing	86
B.1 Worst Case Testing	86
B.2 Thermal Testing Process	86
C: Production Testing	87
D: Packaging	88
E: Design Checklist	89
F: References	91
F.1 Sierra Wireless Documents	91
F.2 Industry/Other Documents	91
G: Abbreviations	93
H: Revision History	100

List of Figures

Figure 2-1: System Block Diagram	19
Figure 2-2: Recommended Schematic for USB Signals.....	27
Figure 2-3: Recommended Schematic for PCIe Signals	29
Figure 2-4: External SIM Application Interface	31
Figure 2-5: SIM Card Contacts (Contact View).....	31
Figure 2-6: Recommended WAKE_ON_WAN_N Connection.....	33
Figure 2-7: Recommended Wireless Disable Connection.....	35
Figure 2-8: Recommended LED Connection.....	37
Figure 3-1: EM929X Module RF Receptacles.....	40
Figure 4-1: Effect of Supercapacitor on PC1.5 Peak Current.....	58
Figure 4-2: Voltage/Temperature Monitoring State Machines	60
Figure 4-3: Power On/Off Timing — PCIe Interface.....	62
Figure 4-4: Signal Timing (Full_Card_Power_Off_N, and USB Enumeration).....	63
Figure 6-1: EM929X Top View and Bottom View	68
Figure 6-2: EM929X Dimensioned View of Mechanical Outline	69
Figure 6-3: EM929X Dimensioned View of Receptacle Locations	70
Figure 6-4: EM929X Dimensioned View of Pin-out	71
Figure 6-5: EM929X Unit Product Marking Example — Laser-etched, Typical Representation .	72
Figure 6-6: Regions requiring thermal dissipation (Bottom view)	73
Figure 6-7: Regions requiring thermal dissipation (Top View).....	73
Figure D-1: Device Placement in Module Tray	88
Figure D-2: Shipping Package	88

List of Tables

Table 1-1: Module Variants	10
Table 1-2: RF Band Support.....	11
Table 1-3: GNSS Frequency Support.....	11
Table 1-4: Required Host-Module Connectors	16
Table 2-1: Host Interface (75-pin) Connections — Module View	20
Table 2-2: Power Supply Requirements	26
Table 2-3: USB Interface.....	26
Table 2-4: PCIe Interface	28
Table 2-5: Supported SIMs	30
Table 2-6: External SIM Interface Signals	30
Table 2-7: Module Control Signals.....	33
Table 2-8: W_DISABLE_N/GPS_DISABLE_N Usage	34
Table 2-9: Full_Card_Power_Off_N and RESET_N Usage.....	35
Table 2-10: DPR Logic	38
Table 2-11: GPIO Antenna Control Signal	39
Table 2-12: Module Configuration Pins	39
Table 3-1: 5G NR Sub-6 GHz/LTE/WCDMA/GNSS Receptacles	40
Table 3-2: 5G NR Sub-6 GHz/LTE/WCDMA/GNSS Antenna Receptacles — RF Technology Support	41
Table 3-3: !DAGFTMRXAGC <path> to Rx Antenna Connector Mapping (Single Band Operation) ..	42
Table 3-4: SRS 5G NR Sub-6 GHz Band Support.....	45
Table 3-5: Supported Frequency Bands, by RAT (5G NR/LTE/3G)	46
Table 3-6: LTE Bandwidth Support	47
Table 3-7: 5G NR Bandwidth and 5G Architecture Support.....	49
Table 3-8: Typical Conducted Rx Sensitivity — 5G NR Sub-6 GHz Bands	50
Table 3-9: Typical Conducted Rx Sensitivity — LTE Bands at 10 MHz BW	51
Table 3-10: Typical Conducted Rx Sensitivity — UMTS Bands	52
Table 3-11: Conducted Maximum Tx Power Tolerances.....	53
Table 3-12: GNSS Specifications	54

Table 4-1: EM929x— USB Averaged Standby DC Power Consumption	55
Table 4-3: EM9291/EM9291P— Averaged Call Mode DC Power Consumption	56
Table 4-2: EM929x— PCIe Averaged Standby DC Power Consumption	56
Table 4-4: EM9293/EM9293P— Averaged Call Mode DC Power Consumption	57
Table 4-5: Miscellaneous DC Power Consumption	58
Table 4-6: Module Power States	59
Table 4-7: Power State Thresholds	60
Table 4-8: PCIe Timing	62
Table 4-9: USB Power-On/Off Timing Parameters	63
Table 6-1: Mechanical and Environmental Specifications	66
Table 7-1: EM929X ISED Antenna Gain and Collocated Radio Transmitter Specifications	76
Table 7-2: EM929X FCC Antenna Gain and Collocated Radio Transmitter Specifications	79
Table 7-3: Standards Compliance	81
Table G-1: Abbreviations and Definitions	93

1: Introduction

The Sierra Wireless EM929X Embedded Module series (EM9291, EM9291P, EM9293, EM9293P) are FirstNet-ready (LTE B14) M.2 modules that provide 5G NR Sub-6 GHz, 4G LTE Advanced Pro, 3G (HSPA+, UMTS) and GNSS connectivity for a wide range of devices and purposes including business, personal, portable computing and communication devices, IoT devices, M2M applications and industrial use cases.

EM929X modules are available in region-specific and function-specific variants. [Table 1-1](#) indicates RF capabilities supported by each variant.

Table 1-1: Module Variants

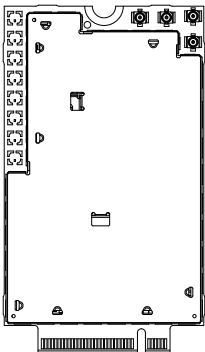
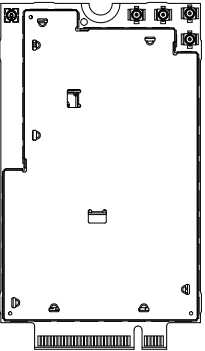
Variant	RF Capabilities (Supported RATs)		
	4G LTE	5G NR Sub-6 GHz	GNSS
EM9291 EM9291P ^a 	Yes	Yes (SA, NSA EN-DC) ^b	Yes (Shared path — ANT1)
EM9293 EM9293P 			Yes (Shared path — ANT1 or Dedicated path — GNSS)

a. Note — EM9291/EM9291P modules include unused solder masks (8) on the top left side of the PCB.

b. "SA" = "Standalone"; "NSA" = "Non-standalone"

Note: Sierra Wireless modules are shipped factory-programmed with industry or mobile operator approved firmware, according to the specific SKU ordered. Periodically, newer firmware versions become available and can include new features, bug fixes, or critical security updates. Sierra Wireless strongly recommends that customers establish their own production capability for updating module firmware on their assembled end platform, in the event that a newer firmware must be installed before deployment. Sierra Wireless also recommends customers design their products to support post-deployment firmware upgrades in the field.

Important: EM929X modules (SKUs with 3V UIM2 support enabled) are not compatible with host platforms that support mmWave — use of these modules will lead to damage on host-side mmWave components due to a voltage mismatch.

1.1 Supported RF bands

The modem supports data operation on 5G NR, 4G LTE and 3G networks over the bands described in [Table 1-2](#), and GNSS operation as described in [Table 1-3](#).

For additional RF details, see [Supported RATs on page 46](#).

Table 1-2: RF Band Support^a

	1	2	3	4	5	6	7	8	12	13	14	17	18	19	20	25	26	28	29	30	32	34	38	39	40	41	42	43	46	48	66	70	71	75	76	77	78	79	106
5G NR Sub-6 GHz	F	F	F	-	F	-	F	F	F	F	F	-	F	-	F	F	F	F	S	F	-	-	T	-	T	T	-	-	-	T	F	F	F	S	S	T	T	T	-
4G LTE	F	F	F	F	F	-	F	F	F	F	F	F	F	F	F	F	F	F	S	F ^b	S	T	T	T	T	T	T	T	T ^c	T	F	-	F	-	-	-	-	-	F
3G	Y	Y	-	Y	Y	Y	-	Y	-	-	-	-	-	Y	-	-	-	-	-	-	-	-	-	-	-	-	-	-	-	-	-	-	-	-	-	-	-	-	-

- a. Supported bands are indicated by:
 - Y=Yes—3G
 - F=FDD band, T=TDD band, S=SDL (Supplementary Downlink) band—5G NR Sub-6 GHz and 4G LTE
- b. Downlink only
- c. Downlink only (LTE-LAA B46)

Table 1-3: GNSS Frequency Support

Supported GNSS Bands	Satellite System Bands within GNSS Bands					EM929X receptacles ^a
	GPS / QZSS	GLONASS	Galileo	BeiDou	NavIC ^b	
L1	L1 (1575.42 MHz)	G1 (1598.0625–1609.3125 MHz)	E1 (1575.42 MHz)	B1I (1561.098 MHz) B1C (1575.42 MHz)	-	ANT1 (All EM929X) GNSS (EM9293/EM9293P only)
L5 ^c	L5 (1176.45 MHz)	-	E5a (1176.45 MHz)	B2a (1176.45 MHz)	L5 (1176.45 MHz)	ANT1 (All EM929X)

- a. See [Figure 3-1, EM929X Module RF Receptacles](#), on page 40.
- b. NavIC is supported only if gpsOneXTRA is used.
- c. The GNSS L1 signal (L1/E1/B1I) must be acquired before L5 acquisition is attempted, since L1 is required for decoding the GNSS L5 signal (L5/E5a/B2a).

1.2 Mechanical Features

- M.2 form factor¹:
 - Type 3052-S3. Socket 2 Configuration State #6 (WWAN Key-B: PCIe, USB3, Port Config 2)
 - Dimensions (Conforms to M.2 form factor width specification): Length — 52 mm; Width — 30 mm; Height — 2.38 mm
- For complete dimensions, see [Mechanical and Environmental Specifications on page 66](#).
- Operating temperature range with host application-appropriate heatsinking, when using a suitable external SIM:
 - Class A (3GPP compliant): -30°C to +70°C
 - Class B (operational, non-3GPP compliant): -40°C to +85°C (reduced operating parameters required)

Note: The optional onboard eSIM is operational between component temperatures of -25°C to +85°C.

Important: For best performance, keep the **internal** module temperature below 100°C (as reported by AT!PCTEMP?). Reduced performance will be experienced above this temperature.
To keep the internal temperature low, proper mounting, heat sinks and active cooling may be required.

1.3 Host Interface Features

EM929X modules support the following host interfaces and features:

- Operating system support:
 - Operating systems:
 - Windows 11 22H2 or later
 - Linux — For Linux version support, refer to [12] *Software Integration and Development Guide for Linux Platforms (Doc# 41113764)* or [13] *Mobile Broadband Package for Linux Release Notes (Doc# 41113802)*.
 - Android — For Android version support, refer to the [14] *Mobile Broadband Package for Android Release Notice (Doc# 41114274)*.
 - Mobile Broadband packages for each system (MBPW, MBPL, MBPA)
To obtain the appropriate mobile broadband package, contact your Sierra Wireless representative.
 - SDK with rich set of APIs and sample applications
- PCIe interface:
 - PCI Gen 3, Single lane
 - Typical PCIe topology:
 - Module is configured as a PCIe End Point (EP).
 - Host is the PCIe root complex (RC) node.
- USB interface:
 - USB 3.2 Gen2x1
 - Configurable USB composite interface — Enable / disable specific interfaces via AT command.
- Debug interface — Diagnostics Monitor (DM) port that generates serial port logs used for debugging
- AT command interface and proprietary extended AT commands.
For details, refer to [1] *EM9 Series AT Command Reference (Doc# 41113480)*.
- SIM support — External SIMs (2) and one embedded SIM

For additional details, refer to [8] *Software Integration and Development Guide for Linux USB Platforms (Doc# 41114212)* and [12] *Software Integration and Development Guide for Linux Platforms (Doc# 41113764)*.

1. Per [20] *PCI Express M.2™ Specification Revision 4.0, Version 1.1*

1.4 Modem Features

- 5G NR Sub-6 GHz, 4G LTE, 3G (DC-HSPA+ / HSPA+ / HSPA / WCDMA) operation
- Multiple (up to 16) cellular packet data profiles
- Multi-SIM support — Two SIMs operating in Dual SIM Single Standby (DSSS) where only one SIM is active at a time:
 - 1 external SIM (UIM1) and 1 internal embedded SIM (UIM2)
 - or*
 - 2 external SIMs (UIM1, UIM2)
- Traditional modem COM port support for AT commands
- Sleep mode for minimum idle power draw
- QoS QCI
- Static and Dynamic IP address. The network may assign a fixed IP address or dynamically assign one using DHCP (Dynamic Host Configuration Protocol).
- PDP context type (IPv4, IPv6, or IPv4v6)
- RFC1144 TCP/IP header compression
- 3GPP R16
- Public Safety 3GPP Features — 3GPP R15 (per 3GPP TS 23.203, TS 29.212): QCI values 65, 66, 69, and 70

1.5 5G FR1 Features

- Supported frequency ranges:
 - FR1 (i.e., 5G NR Sub-6 GHz)
- Carrier aggregation:
 - DL: SA and NSA EN-DC — Up to 3CC intra-band and inter-band CA combinations
 - UL: SA — 2CC inter-band CA combinations
- Network options (applies to all 5G NR bands — see [Table 1-2](#)):
 - DL Standalone (SA) Option 2
 - Non-standalone (NSA) Options 3a/3x. Supports EN-DC for all 5G NR bands — see [CA/EN-DC Support](#).
- Modulation (UL/DL): 256QAM
- 5G MIMO support (for antenna details, see [Table 3-2](#)):

MIMO	Uplink	Downlink
2x2	Bands: n38, n41, n48, n77, n78, n79	Bands: All FR1 bands (Table 1-2)
4x4 ^a	—	Bands: n1, n2, n3, n7, n25, n30, n38, n40, n41, n48, n66, n70, n75, n76, n77, n78, n79

a. 4x4 support is CA combination-dependent. Some combinations are limited to 2x2 MIMO due to hardware limitations.

- HPUE:
 - (All EM929X) PC2 — Bands n41, n77, n78, n79
 - (EM9291P/EM9293P) PC1.5 — Bands n41, n77, n78, n79
- SCS — FDD (15 KHz); TDD (30 KHz)
- Bandwidth:
 - BW per CC — Up to 100 MHz
 - (EM9291 / EM9291P) Maximum aggregate DL BW — ENDC 200 MHz, SA 140 MHz
 - (EM9293 / EM9293P) Maximum aggregate DL BW — ENDC 260 MHz, SA 250 MHz
- Sounding Reference Signal (SRS) — See [Sounding Reference Signal](#).

1.6 LTE Features

- Carrier aggregation:
 - DL: Up to 5CC intra-band and inter-band CA components
 - UL: 2CC intra-band contiguous/non-contiguous and inter-band CA
- LTE MIMO support:

MIMO	Uplink (UL)	Downlink (DL)
2x2	—	Bands: All LTE bands (Table 1-2) Antennas: See Table 3-2.
4x4 ^a	—	Bands: B1, B2, B3, B4, B7, B25, B30, B32, B34, B38, B39, B40, B41, B42, B43, B48, B66

a. 4x4 support is CA combination-dependent. Some combinations are limited to 2x2 MIMO due to hardware limitations.

- HPUE PC2 — Bands B41/B42/B43 standalone mode
- LAA — Band B46
- Modulation:
 - DL modulation: Up to 256QAM
 - UL modulation: Up to 256QAM
- Bandwidth:
 - BW per CC — 20 MHz
 - Maximum aggregate DL BW — (EM9291/EM9291P) 100 MHz; (EM9293/EM9293P) 140 MHz
- CSG support (LTE Femto)
- LTE Advanced receivers (NLIC, eICIC, feICIC)
- Basic cell selection and system acquisition
 - PSS/SSS/MIB decode
 - SIB1–SIB16 decoding
- NAS/AS security procedures
 - Snow 3G/AES/ZUC security
- CQI/RI/PMI reporting
- Paging procedures
 - Paging in Idle and Connected mode
- Dedicated bearer
 - Network-initiated dedicated bearer
 - UE-initiated dedicated bearer
- Multiple PDN connections (IPv4 and IPv6 combinations), subject to operating system support.
- Connected mode intra-LTE mobility
- Idle mode intra-LTE mobility
- iRAT between LTE/3G for idle and connection release with redirection
- Detach procedure
 - Network-initiated detach with reattach required
 - Network-initiated detach followed by connection release
- GNSS L1/L5 reception is maintained in LTE

1.7 WCDMA Features

- Network Assisted Fast Dormancy Release 8
- SRB over HSDPA
- F-DPCH

- CPC
- E-FACH
- HS-FACH
- HS-RACH
- Multi-RAB:
 - Interactive PS
 - Interactive PS/CS
- Discontinuous Transmission (DTX)

1.8 Short Message Service (SMS) Features

- Mobile-originated and mobile-terminated SMS over [IMS](#)
- Mobile-originated and mobile-terminated SMS over SGs

1.9 Position Location (GNSS)

- High-precision GNSS with L1 plus optional L5
- Customizable tracking session
- Automatic tracking session on startup
- Concurrent standalone GNSS (GPS, GLONASS, Galileo, BeiDou, QZSS, NavIC)
- Simultaneous fixes from all GNSS systems
- Assisted GPS (A-GPS)/GLONASS SUPL2.0.4 with configurable aiding refresh rate
- gpsOneXTRA 2.0/3.1
- Antenna receptacles:
 - (All EM929X) ANT1 — Supports L1/L5
 - (EM9293/EM9293P only) GNSS:
 - Supports L1
 - Supports active bias for external LNA

Note: The antenna port (ANT1/GNSS) is software-selectable on EM9293/EM9293P.

1.10 Accessories

A hardware development kit (part #6001349) is available for Sierra Wireless M.2 modules. The kit contains hardware components for evaluating and developing with the module, including:

- Development board
- Cables
- Antennas
- Other accessories

For details, refer to [2] *Sierra Wireless EM919x/EM7690 Development Kit User Guide (Doc# 41113875)*.

Note: The development kit does not include an MHF 7S receptacle to access the EM9293/EM9293P dedicated GNSS antenna (GNSS).

1.11 Required Connectors

Table 1-4 describes the connectors used to integrate the EM929X Embedded Module into your host device.

Table 1-4: Required Host-Module Connectors^a

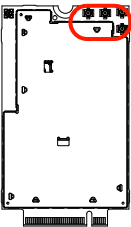
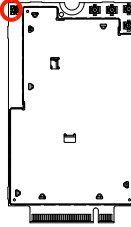
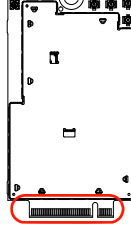
Connector type	Module	Description
MHF 4 RF receptacles ^b — 5G NR Sub-6 GHz/ LTE/GNSS (EM9293/EM9293P shown) 	All EM929X	<ul style="list-style-type: none"> Four MHF 4 receptacles (mate with plugs, e.g., I-PEX 20448-001R-081 or equivalent) To avoid damage when attaching/detaching antenna cables to the receptacles, use an MHF 4 push/pull tool (I-PEX 90435-001 or equivalent). <p><i>Note: 5G NR Sub-6 GHz/LTE is supported on all four receptacles. Only the ANT1 receptacle can be also be used for shared GNSS.</i></p>
MHF 7S RF receptacle ^b — GNSS 	EM9293/ EM9293P only	<ul style="list-style-type: none"> One MHF 7S receptacle (mate with plugs, e.g., I-PEX 20980-001R-13 or equivalent) To avoid damage when attaching/detaching an antenna cable to the receptacle, use an MHF 7S mating/unmating tool (I-PEX 91186-0001 or equivalent). <p><i>Note: Only the EM9293/EM9293P includes the dedicated GNSS receptacle (GNSS). The EM9293/EM9293P can also use ANT1 for shared 5G NR Sub-6 GHz/LTE/GNSS.</i></p>
M.2 (Slot B-compatible) 67-pin edge connector (EM9293/EM9293P shown) 	All EM929X	<ul style="list-style-type: none"> Slot B compatible — Per the M.2 standard ([20] PCI Express M.2™ Specification Revision 4.0, Version 1.1), a generic M.2 Slot B-compatible edge connector on the motherboard uses a mechanical key to mate with the 67-pin notched module connector. Manufacturers include LOTES, Kyocera, JAE, TE Connectivity, and Longwell.

- a. Manufacturers/part numbers are for reference only and are subject to change. Choose connectors that are appropriate for your own design.
- b. MHF 4 and MHF 7S RF receptacles (PCB connectors) are mounted on EM929X modules. The host must mate these with corresponding RF plugs (cable connectors).

1.12 Integration Guidance

When integrating the EM929X Embedded Module, the following items, if applicable, must be considered:

- Mounting** — Effect on temperature, shock, and vibration performance
- Power supply** — Impact on battery drain and possible RF interference
- Antenna location and type** — Impact on RF performance
- Regulatory approvals** — See [Regulatory Compliance and Industry Certifications on page 75](#).
- Service provisioning** — Manufacturing process
- Software** — See [Software on page 65](#).
- Host interface** — Compliance with interface voltage levels

2: Electrical Specifications

The system block diagram in [Figure 2-1](#) represents the EM929X module integrated into a host system.

The module includes the following interfaces to the host:

- Power state signals:
 - Full_Card_Power_Off_N— Active-low input from the host— Low turns the module off, high turns the module on.
 - RESET_N— Active low input from the host— Low resets the module.
 - WAKE_ON_WAN_N— Active low output to the host— Low wakes the host when specific events occur.
- Radio control signals:
 - W_DISABLE_N— Active low input from the host— Low disables the main RF radio or triggers a 'Dying Gasp' SMS, depending on configuration.
 - GPS_DISABLE_N— Active low input from the host— Low disables the GNSS radio receiver.
 - Dynamic power reduction (DPR)— Signal used to adjust Tx power to meet FCC SAR requirements. For details, see [Tx Power Control on page 38.](#)
- Antenna:
 - Antenna Receptacles:

RAT	Receptacle			Populated on Module		Notes
	Qty	Type	Name	EM9291 EM9291P	EM9293 EM9293P ^a	
LTE/ 5G NR Sub-6 GHz/ GNSS	4	MHF 4	ANT0–ANT3	Y	Y	Shared GNSS supported only on ANT1
GNSS	1	MHF 7S	GNSS	—	Y	Dedicated GNSS (L1 only)

- a. Only EM9293/EM9293P modules include the dedicated GNSS receptacle (GNSS), and can use either ANT1 or GNSS (software-selectable) for GNSS.

For details, see [RF Specifications on page 40](#).

Important: *Systems connected to a live network must have all four MHF 4 antennas (ANT0–ANT3) connected. (The dedicated GNSS antenna (GNSS) is only required if the dedicated GNSS antenna path is configured.)*

- Antenna control signals:
 - ANT_CTRL0— GPIO-based external antenna tuner control
 - RFFE— RF Front-End interface for controlling Qualcomm antenna tuners
- SIMs:
 - SIMs— External end embedded SIMs:
 - External SIM(s)— Supports connection to SIM holder(s)/tray(s) mounted on the host platform.
 - Supports two external SIMs (UIM1, UIM2).
 - Embedded SIM (eSIM)— A SIM that is mounted/embedded internal to the module.
 - eSIM support is SKU-dependent.
 - The eSIM is multiplexed with the second external SIM (UIM2).
 - For modules that support UIM2, either the external SIM or the eSIM can be active— the active SIM can be specified through configuration or software control. (i.e., It is not possible to have both the external SIM and eSIM active on UIM2 at the same time.)

-
- The module implements Dual SIM Single Standby (DSSS) to determine the active SIM between the UIM1 (external) and UIM2 (external or eSIM) interfaces. (e.g., UIM1 and UIM2 (eSIM), or UIM1 and UIM2 (external))
 - SIM detect—Internal pull-ups on the module (on SIM1_DETECT and UIM2_PRES signals, see [Table 2-1](#)) detect whether SIMs are present in the external SIM trays:
 - If a SIM is not inserted, the pin will be shorted to ground.
 - If a SIM is present, the pin will be an open circuit.
 - Host interface buses:
 - Supported bus types:
 - PCIe—PCIe Gen3 single lane interface to the host for data, control, debug and status information. (PCIe Gen2 backward-compatible)
 - USB—USB 3.2 Gen2x1 interface to the host for data, control, debug and status information. (USB 2.0 backward-compatible)

Note: USB 2.0 operation is not officially tested or commercially supported.

- Bus selection signal:
 - PCIE_DIS—Host interface selection signal. (High—USB; Low / Hi-Z / Disconnected—PCIe)

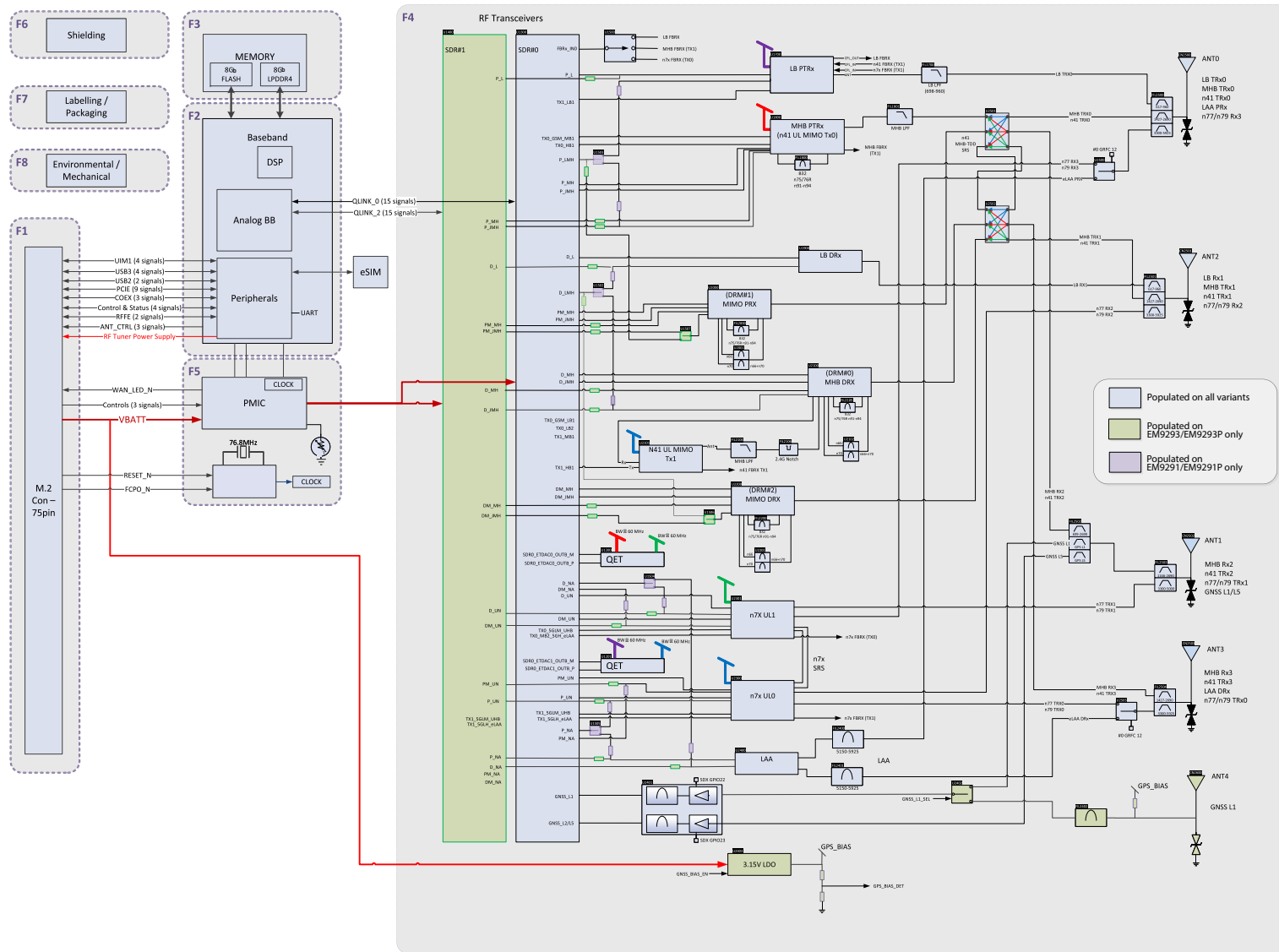

Figure 2-1: System Block Diagram

2.1 M.2 (Host) Interface Pin Assignments

The EM929X module's host I/O connector provides pins for power, serial communications, and control. Pin assignments are listed in [Table 2-1](#).

Refer to the following tables for pin details based on interface types:

- [Table 2-2, Power Supply Requirements](#), on page 26
- [Table 2-3, USB Interface](#), on page 26
- [Table 2-4, PCIe Interface](#), on page 28
- [Table 2-6, External SIM Interface Signals](#), on page 30
- [Table 2-7, Module Control Signals](#), on page 33
- [Table 2-8, W_DISABLE_N/GPS_DISABLE_N Usage](#), on page 34
- [Table 2-9, Full_Card_Power_Off_N and RESET_N Usage](#), on page 35
- [Table 2-12, Module Configuration Pins](#), on page 39

Note: Unless indicated otherwise, leave unused inputs and outputs as no-connects (NC).

Important: *The host must not drive any signals to the module until > 100 ms from the start of the power-on sequence.*

Table 2-1: Host Interface (75-pin) Connections — Module View

Pin	Signal name	Pin type ^a	Description	Signal Direction ^b	Active state	Voltage levels (V)		
						Min	Typ	Max
1	CONFIG_3 ^c		Module identification (Pin is NC) <i>Note: The host must not repurpose this pin.</i>					
2	VCC	V	Power source	Input	Power	3.135	3.3	4.4
3	GND	V	Ground	Input	Power	–	0	–
4	VCC	V	Power source	Input	Power	3.135	3.3	4.4
5	GND	V	Ground	Input	Power	–	0	–
6	Full_Card_Power_Off_N	PD	Turn modem on	Input	High	1.35	–	4.4
			Turn modem off		Low	-0.3	–	0.5
7	USB_D+	I/O	USB data positive	Input/Output	Differential	–	–	–

Table 2-1: Host Interface (75-pin) Connections — Module View (Continued)

Pin	Signal name	Pin type ^a	Description	Signal Direction ^b	Active state	Voltage levels (V)		
						Min	Typ	Max
8	W_DISABLE_N	PU	Wireless Disable (WWAN radio) or Dying Gasp trigger	Input	High	1.1	–	4.4
					Low	–	–	0.4
9	USB_D-	I/O	USB data negative	Input/Output	Differential	–	–	–
10	WWAN_LED_N	OC	LED Driver	Output	Low	0	–	0.15
11	GND	V	Ground	Input	Power	–	0	–
12	Key	Notch location						
13	Key	Notch location						
14	Key	Notch location						
15	Key	Notch location						
16	Key	Notch location						
17	Key	Notch location						
18	Key	Notch location						
19	Key	Notch location						
20	PCI_E_DIS	PD	Host interface selection	Input	High	1.5	1.80	2.10
					Low	-0.3	–	0.5
21	CONFIG_0 ^c		Module identification (Pin is tied to Ground) <i>Note: The host must not repurpose this pin.</i>					
22	VBUS_SENSE	PD	USB Detection	Input	High	1.6	–	5.25
23	WAKE_ON_WAN_N	OC	Wake Host	Output	Low	0	–	0.15
24 ^d	VCC	V	Power source	Input	Power	3.135	3.3	4.4
25	DPR	I	Dynamic power reduction	Input	High	1.17	1.80	2.10
					Low	-0.3	–	0.63

Table 2-1: Host Interface (75-pin) Connections — Module View (Continued)

Pin	Signal name	Pin type ^a	Description	Signal Direction ^b	Active state	Voltage levels (V)		
						Min	Typ	Max
26	GPS_DISABLE_N	PU	Wireless disable (GNSS radio)	Input	High	1.1	–	4.4
					Low	–	–	0.4
27	GND	V	Ground	Input	Power	–	0	–
28	PLA_S2_N	O	Power loss acknowledge	Output	High	1.35	1.80	1.90
					Low	-0.3	–	0.63
29	USB3_TXM	O	USB3 Negative Transmit Data	Output	Differential	0.1	0.56	1.2
30	UIM1_RESET_N	O	SIM Reset (1.8V/3V SIM)	Output	High	2.55 (3V SIM) 1.35 (1.8V SIM)	3.00 (3V SIM) 1.80 (1.8V SIM)	3.10 (3V SIM) 1.90 (1.8V SIM)
					Low	0	–	0.45
31	USB3_TXP	O	USB3 Positive Transmit Data	Output	Differential	0.1	0.56	1.2
32	UIM1_CLK	O	SIM Clock (1.8V/3V SIM)	Output	High	2.55 (3V SIM) 1.35 (1.8V SIM)	3.00 (3V SIM) 1.80 (1.8V SIM)	3.10 (3V SIM) 1.90 (1.8V SIM)
					Low	0	–	0.45
33	GND	V	Ground	Input	Power	–	0	–
34	UIM1_DATA	I/O	SIM I/O pin (1.8V/3V SIM)	Input	High	2.10 (3V SIM) 1.17 (1.8V SIM)	3.00 (3V SIM) 1.80 (1.8V SIM)	3.30 (3V SIM) 2.10 (1.8V SIM)
					Low	-0.30 (3V SIM) -0.30 (1.8V SIM)	–	0.60 (3V SIM) 0.35 (1.8V SIM)
				Output	High	2.55 (3V SIM) 1.35 (1.8V SIM)	3.00 (3V SIM) 1.80 (1.8V SIM)	3.10 (3V SIM) 1.90 (1.8V SIM)
					Low	0	–	0.40
35	USB3_RXM	I	USB3 Negative Receive Data	Input	Differential	0.1	–	1.2

Table 2-1: Host Interface (75-pin) Connections — Module View (Continued)

Pin	Signal name	Pin type ^a	Description	Signal Direction ^b	Active state	Voltage levels (V)		
						Min	Typ	Max
36	UIM1_PWR	V	SIM VCC supply (1.8V/3V SIM)	Output	Power	2.90 (3V SIM) 1.75 (1.8V SIM)	3.00 (3V SIM) 1.80 (1.8V SIM)	3.10 (3V SIM) 1.85 (1.8V SIM)
37	USB3_RXP	I	USB3 Positive Receive Data	Input	Differential	0.1	–	1.2
38 ^d	VCC	V	Power source	Input	Power	3.135	3.3	4.4
39	GND	V	Ground	Input	Power	–	0	–
40	UIM2_PRES	PU	SIM indication ^f	Input	High ^e	0 V — SIM not present Open circuit — SIM present		
41	PCIE_TXM0	O	PCIe Negative Transmit Data	Output	Differential	0.05	0.12	1.2
42	UIM2_DATA	I/O	SIM I/O pin (1.8V/3V SIM) ^f	Input	High	2.10 (3V SIM) 1.17 (1.8V SIM)	3.00 (3V SIM) 1.80 (1.8V SIM)	3.30 (3V SIM) 2.10 (1.8V SIM)
					Low	-0.30 (3V SIM) -0.30 (1.8V SIM)	–	0.60 (3V SIM) 0.35 (1.8V SIM)
				Output	High	2.55 (3V SIM) 1.35 (1.8V SIM)	3.00 (3V SIM) 1.80 (1.8V SIM)	3.10 (3V SIM) 1.90 (1.8V SIM)
					Low	0	–	0.40
43	PCIE_TXP0	O	PCIe Positive Transmit Data0	Output	Differential	0.05	0.12	1.2
44	UIM2_CLK	O	SIM Clock (1.8V/3V SIM) ^f	Output	High	2.55 (3V SIM) 1.35 (1.8V SIM)	3.00 (3V SIM) 1.80 (1.8V SIM)	3.10 (3V SIM) 1.90 (1.8V SIM)
					Low	0	–	0.45
45	GND	V	Ground	Input	Power	–	0	–
46	UIM2_RESET_N	O	SIM Reset (1.8V/3V SIM) ^f	Output	High	2.55 (3V SIM) 1.35 (1.8V SIM)	3.00 (3V SIM) 1.80 (1.8V SIM)	3.10 (3V SIM) 1.90 (1.8V SIM)
					Low	0	–	0.45
47	PCIE_RXM0	I	PCIe Negative Receive Data0	Input	Differential	0.05	–	1.2

Table 2-1: Host Interface (75-pin) Connections — Module View (Continued)

Pin	Signal name	Pin type ^a	Description	Signal Direction ^b	Active state	Voltage levels (V)		
						Min	Typ	Max
48	UIM2_PWR	V	SIM VCC supply (1.8V/3V SIM) ^f	Output	Power	2.90 (3V SIM) 1.75 (1.8V SIM)	3.00 (3V SIM) 1.80 (1.8V SIM)	3.10 (3V SIM) 1.85 (1.8V SIM)
49	PCIE_RXP0	I	PCIe Positive Receive Data0	Input	Differential	0.05	–	1.2
50	PCIE_PERST_N	I	PCIe Reset (Note: This signal is used as one part of the PCIe interface initialization sequence. Do not attempt to use it to reinitialize the PCIe interface. For additional details, see PCIE_PERST_N on page 29.)	Input	High	1.5	–	VCC
					Low	0	–	0.7
51	GND	V	Ground	Input	Power	–	0	–
52	PCIE_CLKREQ_N	OC	PCIe Clock Request	Output	Low	0	–	0.35
53	PCIE_REFCLKM	I	PCIe Negative 100 MHz Reference Clock	Input	Differential	-0.3	0.55	1.15
54	PCIE_PEWAKE_N	OC	PCIe Wake	Output	Low	0	–	0.35
55	PCIE_REFCLKP	I	PCIe Positive 100 MHz Reference Clock	Input	Differential	-0.3	0.55	1.15
56	RFFE_CLK	O	RFFE Clock	Output	High	1.35	1.80	1.90
					Low	0	–	0.45
57	GND	V	Ground	Input	Power	–	0	–
58	RFFE_DATA	I/O	RFFE Data	Input	High	1.17	1.80	2.10
					Low	-0.3	–	0.63
				Output	High	1.35	1.80	1.90
					Low	0	–	0.45
59	ANT_CTRL0	O	External antenna tuner control	Output	High	1.35	1.80	1.90
					Low	0	–	0.45
60	Reserved		Reserved — Host must not repurpose this pin.					
61	NC		Reserved — Host must not repurpose this pin.					

Table 2-1: Host Interface (75-pin) Connections — Module View (Continued)

Pin	Signal name	Pin type ^a	Description	Signal Direction ^b	Active state	Voltage levels (V)		
						Min	Typ	Max
62	Reserved		Reserved — Host must not repurpose this pin.					
63	NC		Reserved — Host must not repurpose this pin.					
64	Reserved		Reserved — Host must not repurpose this pin.					
65	1P8_TUNER_PWR	V	External antenna tuner power supply (2 mA max voltage source)	Output	Power	1.60	1.80	1.90
66	SIM1_DETECT	PU	SIM indication	Input	High ^e	0 V — SIM not present Open circuit — SIM present		
67	RESET_N	PU	Reset module	Input	Low	-0.3	–	0.5
68 ^d	VCC	V	Power source	Input	Power	3.135	3.3	4.4
69	CONFIG_1 ^c		Module identification (Pin is tied to Ground) <i>Note: The host must not repurpose this pin.</i>					
70	VCC	V	Power source	Input	Power	3.135	3.3	4.4
71	GND	V	Ground	Input	Power	–	0	–
72	VCC	V	Power source	Input	Power	3.135	3.3	4.4
73	GND	V	Ground	Input	Power	–	0	–
74	VCC	V	Power source	Input	Power	3.135	3.3	4.4
75	CONFIG_2 ^c		Module identification (Pin is NC) <i>Note: The host must not repurpose this pin.</i>					

- a. Pin types: I — Input; O — Digital output; I/O — Input/Output; OC — Open Collector output; PU — Digital input (internal pull up); PD — Digital input (internal pull down); V — Power or ground
- b. Signal direction: Indicates direction from module’s point of view (e.g. ‘Output’ from module to host, ‘Input’ to module from host.)
- c. CONFIG_0/CONFIG_1/CONFIG_2/CONFIG_3 — The host platform reads these pins to determine that the EM929X module is an M.2 Type 3052-S3 (Socket 2 Configuration State #6 (WWAN Key-B: PCIe, USB3, Port Config 2) device.
- d. VCC pins 24, 38, and 68 — These pins are optional, and can be left as NC.
- e. SIM detect pins (SIM1_DETECT, UIM2_PRES): Active logic state is configurable.
- f. UIM2 support for 3 V SIMs is SKU-specific. **Important:** EM929X modules SKUs with 3V UIM2 support enabled are not compatible with host platforms that support mmWave — use of these modules will lead to damage on host-side mmWave components due to a voltage mismatch.

2.2 Power Supply

The host provides power to the EM929X module through multiple power and ground pins as summarized in [Table 2-2](#).

The host must provide safe and continuous power (via battery or a regulated power supply) at all times; the module does not have an independent power supply, or protection circuits to guard against electrical issues.

Table 2-2: Power Supply Requirements

Name	Pins	Specification	Min	Typ	Max	Units
VCC ^a (3.3V)	2, 4, 24 ^b , 38 ^b , 68 ^b , 70, 72, 74	Voltage range	3.135	3.3	4.4	V
		Ripple voltage	—	—	100	mV _{pp}
GND	3, 5, 11, 27, 33, 39, 45, 51, 57, 71, 73		—	0	—	V

- a. A 1.5 mF supercapacitor connected to VCC is strongly recommended to mitigate the module's peak current. For details, see [Table 4-5, Miscellaneous DC Power Consumption](#), on page 58 and [4.1.1 Peak Current Mitigation on page 58](#).
- b. VCC pins 24, 38, and 68— These pins are optional, and can be left as NC.

2.3 USB Interface

Important: *Host support for USB 3.2 signals is required when USB is selected as the host interface.*

The EM929X module supports a USB 3.2 Gen2x1 interface for communication between the host and module. (USB 2.0 backward-compatible. Note — USB 2.0 operation is not officially tested or commercially supported.)

The USB interface complies with [21] *Universal Serial Bus 3.2 Specification, Revision 1.1* (subject to limitations described below), and the host platform must be designed to the same standards.

Table 2-3: USB Interface

Name	Pin	Description
USB_D+	7	(USB 2 Hi-speed) Data positive
USB_D-	9	(USB 2 Hi-speed) Data negative
VBUS_SENSE	22	USB detection
USB3_TXM ^a	29	(USB 3 Superspeed+) Transmit data negative
USB3_TXP ^a	31	(USB 3 Superspeed+) Transmit data positive
USB3_RXM ^a	35	(USB 3 Superspeed+) Receive data negative
USB3_RXP ^a	37	(USB 3 Superspeed+) Receive data positive

- a. Signal directions (Tx/ Rx) are from the module's point of view.

Note: The USB interface does not activate until VBUS_SENSE is connected.

2.3.1 USB Host-side Recommendation

Series capacitors are recommended on the host side for the EM929X module’s USB3_RXM/USB3_RXP signals, as shown in Figure 2-2.

(No capacitors are required on the host side for the EM929X module’s USB3_TXM/USB3_TXP signals.)

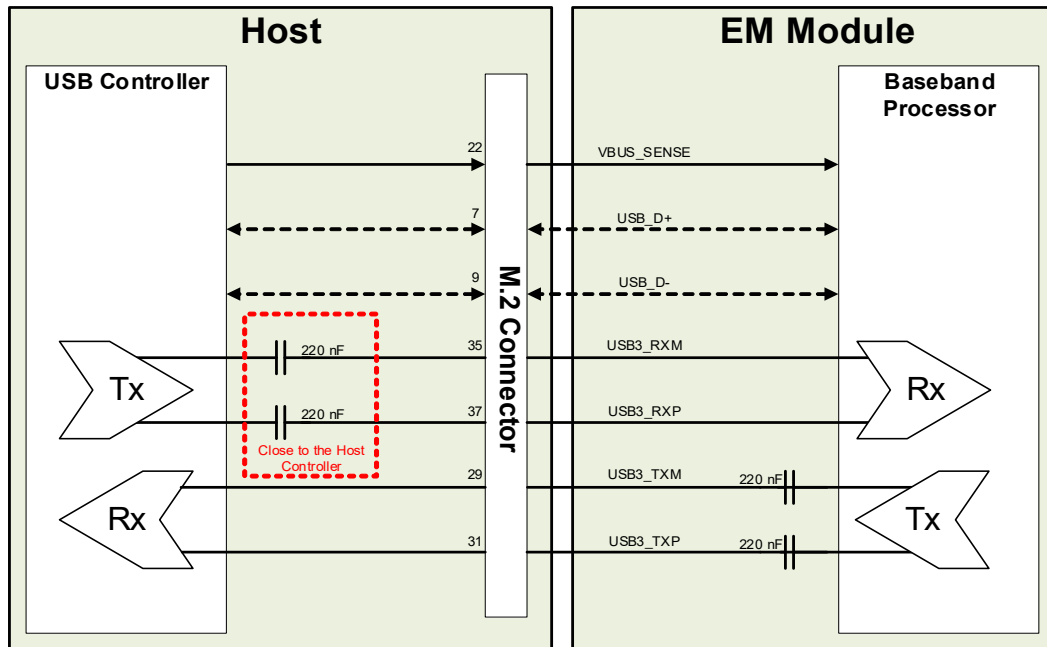

Figure 2-2: Recommended Schematic for USB Signals

2.4 PCIe Interface

Important: For best performance, host support for PCIe Gen3 signals is required when PCIe is selected as the host interface.

The EM929X module supports a PCIe interface for communication between the host and module.

The PCIe interface complies with the PCI Express® Card Electromechanical Specification Revision 3.0.

Note: Per the PCIe specification, PCIe-compliant devices are backward- and forward-compatible with all generations. When connected to a host device, the EM929X module establishes a link at the highest common specification—i.e., PCIe Gen3 when connected to a Gen3-compliant or higher host, or Gen2 when connected to a Gen2-compliant host. If for some reason the host supports only PCIe Gen4 or higher, a PCIe link will not be established with the module.

Table 2-4: PCIe Interface

	Name	Pin	Description
PCIe	PCIE_TXM0 ^a	41	PCIe Negative Transmit Data0
	PCIE_TXP0 ^a	43	PCIe Positive Transmit Data0
	PCIE_RXM0 ^a	47	PCIe Negative Receive Data0
	PCIE_RXP0 ^a	49	PCIe Positive Receive Data0
	PCIE_PERST_N	50	PCIe Reset (Note: This signal is used as one part of the PCIe interface initialization sequence. Do not attempt to use it (solely) to reinitialize the PCIe interface. For additional details, see PCIE_PERST_N on page 29.)
	PCIE_CLKREQ_N	52	PCIe Clock Request
	PCIE_REFCLKM	53	PCIe Negative Reference Clock
	PCIE_PEWAKE_N	54	PCIe Wake
	PCIE_REFCLKP	55	PCIe Positive Reference Clock

a. Signal directions (Tx/Rx) are from the module's point of view.

Note: EM929X modules support Active State Power Management (ASPM) L1 and L0s (PCIE_CLKREQ_N is required to support Clock Power Management in ASPM L1).

Note: EM929X modules do not have Optimized Buffer Flush/Fill (OBFF) support.

2.4.1 PCIe Host-side Recommendation

Series capacitors are required on the host side for the EM929X module's PCIE_RXM0/PCIE_RXP0 signals (per [20] *PCI Express M.2™ Specification Revision 4.0, Version 1.1*). Also, pull-ups are recommended on the PCIE_PEWAKE_N and PCIE_CLKREQ_N signals, as shown below.

(No capacitors are required on the host side for the EM929X module's PCIE_TXM0/PCIE_TXP0 signals.)

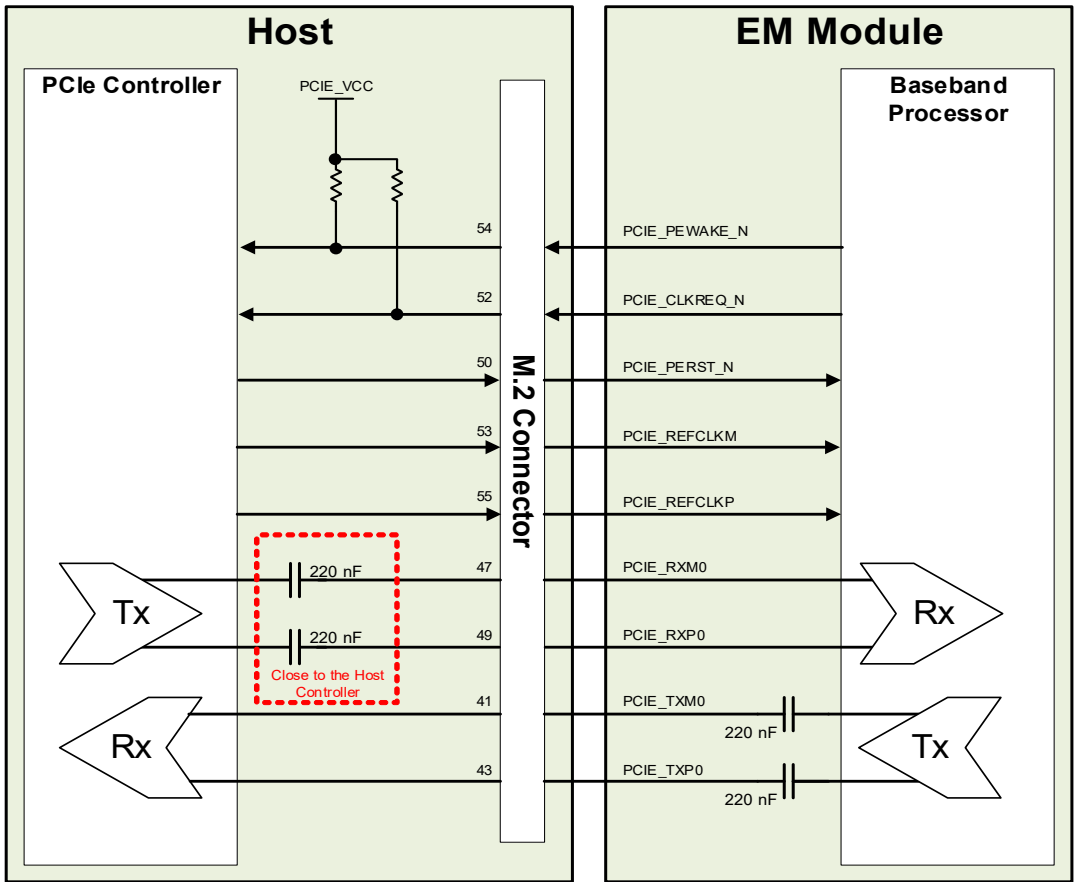

Figure 2-3: Recommended Schematic for PCIe Signals

2.4.2 PCIE_PE_WAKE_N

Depending on the host platform’s configuration, PCIE_PE_WAKE_N can be used by the module to wake the host when the PCIe link is in a power saving state.

EM929X and EM91XX modules support the same PCIe functionality. For details, refer to [7] *EM919x/EM7690 PCIe Integration Guide (Doc# 41114276)*.

2.4.3 PCIE_PERST_N

PCIE_PERST_N (PCIe Reset) is used as part of the PCIe interface initialization sequence during power-on, and in the power-off sequence (see [Power On/Off Timing for PCIe Interface on page 61](#)).

Important: If the PCIe interface has stalled, this signal cannot be used to reinitialize it—the interface is not hot-plug compatible, so PCIe link training must be restarted using an appropriate method:

- If the host is designed to restart PCIe link training—the [Required Shutdown Sequence on page 63](#) can be used to properly power-off the module. Then the module can be powered-on and the host platform can restart the link training.
- If the host is not designed to restart PCIe link training—Perform a complete system reset (i.e., reset the host platform).

2.5 SIM Interface

Note: Host support for SIM interface signals is required.

The EM929X supports the following SIMs (Subscriber Identity Module):

Table 2-5: Supported SIMs

SIM port	SIM Type	Operating voltage	Details
UIM1	External SIM	1.8 V / 3 V	Dedicated SIM port
UIM2	External SIM	1.8 V / 3 V ^a	Shared (multiplexed) SIM port Only one of the two UIM2 SIMs (external or eSIM) will be active at any time. The active SIM is set through configuration or software control.
	Embedded SIM (eSIM) ^b		

- a. UIM2 support for 3 V SIMs is SKU-specific. **Important:** EM929X modules SKUs with 3V UIM2 support enabled are not compatible with host platforms that support mmWave — use of these modules will lead to damage on host-side mmWave components due to a voltage mismatch.
- b. Consumer-eUICC embedded SIM that is internal to the module (SKU-dependent).

The SIM pins (Table 2-6 on page 30) provide the connections necessary to interface to external SIM sockets located on the host platform as shown in Figure 2-4 on page 31. Voltage levels over this interface comply with 3GPP standards.

The SIM connector types used depend on how the host platform exposes the SIM sockets.

Table 2-6: External SIM Interface Signals

SIM	Name	Pin	Description	SIM contact ^a	Notes
Primary	UIM1_RESET	30	Reset	2	Active low SIM reset
	UIM1_CLK	32	Serial clock	3	Serial clock for SIM data
	UIM1_DATA	34	Data I/O	7	Bi-directional SIM data line
	UIM1_PWR	36	SIM voltage	1	Power supply for SIM
	SIM1_DETECT	66	SIM indication	–	Input from host indicating whether SIM is present or not <ul style="list-style-type: none"> ▪ Grounded if no SIM is present ▪ No-connect (floating) if SIM is inserted
Secondary	UIM2_RESET_N	46	Reset	2	Active low SIM reset
	UIM2_CLK	44	Serial clock	3	Serial clock for SIM data
	UIM2_DATA	42	Data I/O	7	Bi-directional SIM data line
	UIM2_PWR	48	SIM voltage	1	Power supply for SIM
	UIM2_PRES	40	SIM indication	–	Input from host indicating whether SIM is present or not <ul style="list-style-type: none"> ▪ Grounded if no SIM is present ▪ No-connect (floating) if SIM is inserted

- a. See Figure 2-5 on page 31 for SIM card contacts.

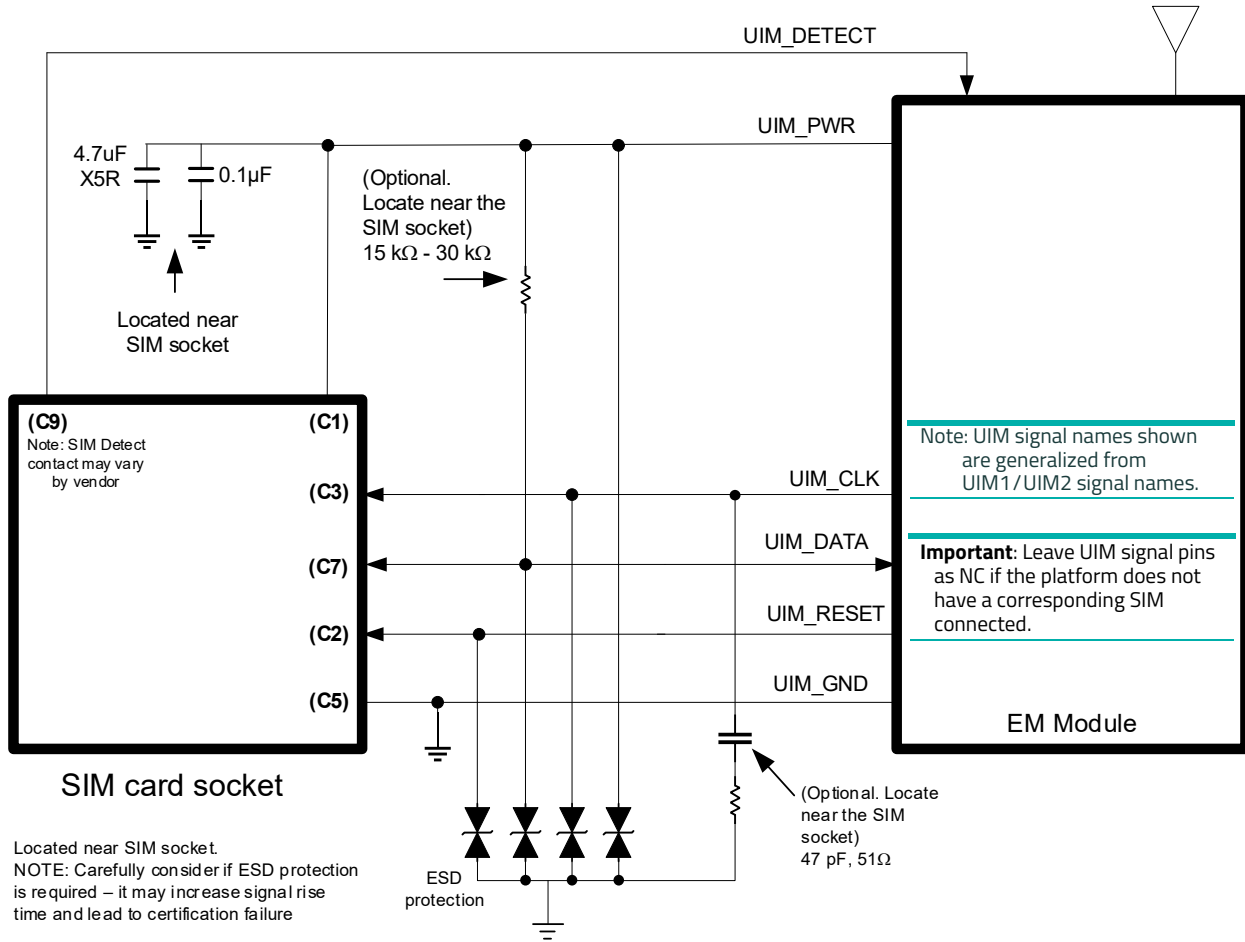

Figure 2-4: External SIM Application Interface

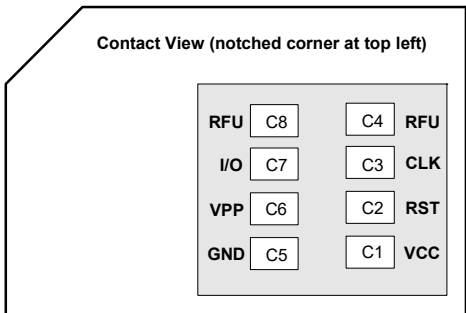

Figure 2-5: SIM Card Contacts (Contact View)

2.5.1 External SIM Interface Implementation

Note: For interface design requirements, refer to ETSI TS 102 230 V5.5.0, section 5.2.

When designing the external SIM interface, you must make sure that SIM signal integrity is not compromised.

Some design recommendations include:

- EM929X modules (SKUs with 3V UIM2 support enabled) are not compatible with host platforms that support mmWave — use of these modules will lead to damage on host-side mmWave components due to a voltage mismatch.
- Total impedance of the VCC and GND connections to the SIM, measured at the module connector, should be less than 1 Ω to minimize voltage drop (includes any trace impedance and lumped element components — inductors, filters, etc.).
- Position the SIM connector ≤ 10 cm from the module. If a longer distance is required because of the host platform design, use a shielded wire assembly — connect one end as close as possible to the SIM connector and the other end as close as possible to the module connector. The shielded assembly may help shield the SIM interface from system noise.
- Avoid routing the clock and data lines (UIM1_CLK, UIM1_DATA, UIM2_CLK, UIM2_DATA) in parallel over distances > 2 cm — cross-coupling of a clock and data line pair can cause failures.
- 3GPP has stringent requirements for I/O rise time (< 1 μ s), signal level limits, and noise immunity — consider this carefully when developing your PCB layout.
 - Keep signal rise time < 1 μ s — keep SIM signals as short as possible, and keep very low capacitance traces on the data and clock signals (UIM1_CLK, UIM1_DATA, UIM2_CLK, UIM2_DATA). High capacitance increases signal rise time, potentially causing your device to fail certification tests.
- Add external pull-up resistors (15 k Ω –30 k Ω), if required, between the data and power lines (UIM1_DATA, UIM1_PWR, UIM2_DATA, UIM2_PWR) to optimize the signal rise time.
- VCC line should be decoupled close to the SIM socket.
- Make sure that placement and routing of SIM signals and connectors supports SIM clock rates up to 5 MHz (per 3GPP specification).
- You must decide whether additional ESD protection is required for your product, as it is dependent on the platform, mechanical enclosure, and SIM connector design. The SIM pins will require additional ESD protection if they are exposed to high ESD levels (i.e. can be touched by a user).
- Putting optional decoupling capacitors on the SIM power line (UIM1_PWR, UIM2_PWR) near the SIM socket is recommended — the longer the trace length (impedance) from the socket to the module, the greater the capacitance requirement to meet compliance tests.
- Putting an optional series capacitor and resistor termination (to ground) on the clock line (UIM1_CLK, UIM2_CLK) at the SIM socket to reduce EMI and increase signal integrity is recommended if the trace length between the SIM socket and module is long — a 47 pF capacitor and 50 Ω resistor are recommended.
- If you wish to perform pre-compliance testing of your prototype host hardware, consider testing it with a Compron IT³ SIM test device at a suitable testing facility.

2.6 Control Interface (Signals)

The EM929X module provides signals for:

- Waking the host when specific events occur
- Host platform control of the module's radios
- Host platform control of module power
- Module status indication to host
- Host interface selection (i.e. PCIe, USB)

Note: Host support for Full_Card_Power_Off_N is required, and support for other signals in Table 2-7 is optional.

These signals are summarized in [Table 2-7](#).

Table 2-7: Module Control Signals

Name	Pin	Description	Type ^a
Full_Card_Power_Off_N	6	On/off control	PD
W_DISABLE_N	8	Wireless disable (Main RF) or Dying Gasp trigger	PU
WWAN_LED_N	10	LED driver	OC
PCIE_DIS	20	Host interface selection	PD
WAKE_ON_WAN_N	23	Wake host	O
GPS_DISABLE_N	26	Wireless disable (GNSS)	PU
PLA_S2_N	28	Power loss acknowledge	O
RESET_N	67	Reset module	PU

a. O— Digital pin Output; OC— Open Collector output; PD— Digital pin Input, internal pull down; PU— Digital pin Input, internal pull up

2.6.1 WAKE_ON_WAN_N — Wake Host

Note: Host support for WAKE_ON_WAN_N is optional.

The EM929X module uses WAKE_ON_WAN_N to wake the host when specific events occur.

The host must provide a 5kΩ–100kΩ pull-up resistor that considers total line capacitance (including parasitic capacitance) such that when WAKE_ON_WAN_N is deasserted, the line will rise to 3.3 V (Host power rail) in < 100 ns.

See [Figure 2-6 on page 33](#) for a recommended implementation.

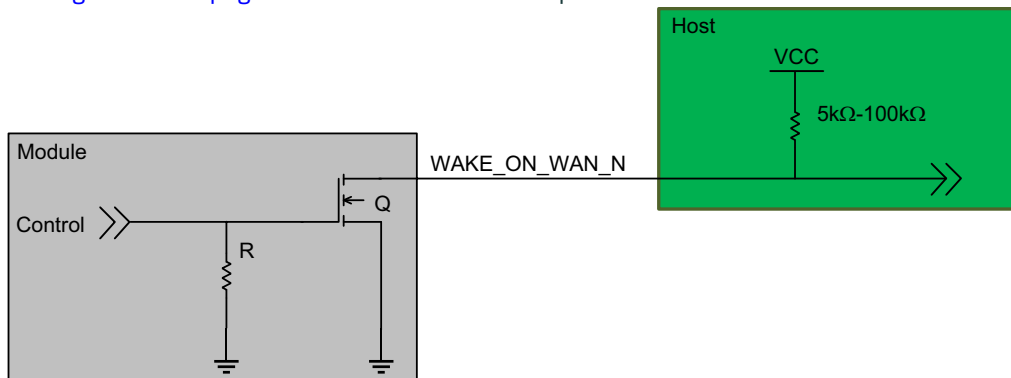

Figure 2-6: Recommended WAKE_ON_WAN_N Connection

2.6.2 W_DISABLE_N (WWAN Disable) and GPS_DISABLE_N (GNSS Disable)

Note: Host support for WWAN/GNSS disable signals is optional.

The host platform can use W_DISABLE_N and GPS_DISABLE_N as follows:

- W_DISABLE_N — Control the radio state (enable/disable the WWAN or radio modem), or trigger a 'Dying Gasp' SMS when the platform is about to lose power.

Note: When the 'Dying Gasp' feature is enabled, W_DISABLE_N cannot be used to control the radio state. For details, refer to [1] EM9 Series AT Command Reference (Doc# 41113480) topics for !CUSTOM="DGENABLE", !WDISABLE, and !PCINFO.

- GPS_DISABLE_N — Enable/disable GNSS functionality.

Letting these signals float high allows the module to operate normally. These pins have 470kΩ pull-up resistors. See Figure 2-7 for a recommended implementation.

When integrating with your host platform, keep the following in mind:

- The signal is an input to the module and should be driven LOW to turn the radio off, or HIGH or floating to keep it on.
- If the host never needs to assert this power state control to the module, leave this signal unconnected from the host interface.

Table 2-8: W_DISABLE_N / GPS_DISABLE_N Usage

Name	Pin	Description / notes
W_DISABLE_N	8	Feature configuration (Dying Gasp)-dependent behavior: <ul style="list-style-type: none"> Enable/disable the WWAN or radio modem^a. When disabled, the modem cannot transmit or receive. <ul style="list-style-type: none"> Keep modem always on — Leave as not connected or drive HIGH. Turn modem off — Drive LOW. or <ul style="list-style-type: none"> If the Dying Gasp feature is enabled, trigger a 'Dying Gasp' SMS.
GPS_DISABLE_N	26	Enable/disable GNSS functionality ^a <ul style="list-style-type: none"> Enable GNSS functionality — Leave as not connected or drive HIGH. Disable GNSS functionality — Drive LOW. For details on enabling/disabling GNSS functionality, refer to the AT!CUSTOM="GPSENABLE" command in [1] EM9 Series AT Command Reference (Doc# 41113480).

a. The host must implement an open collector driver where a Low signal turns off the modem or disables GNSS functionality, and a high signal turns on the modem or enables GNSS functionality.

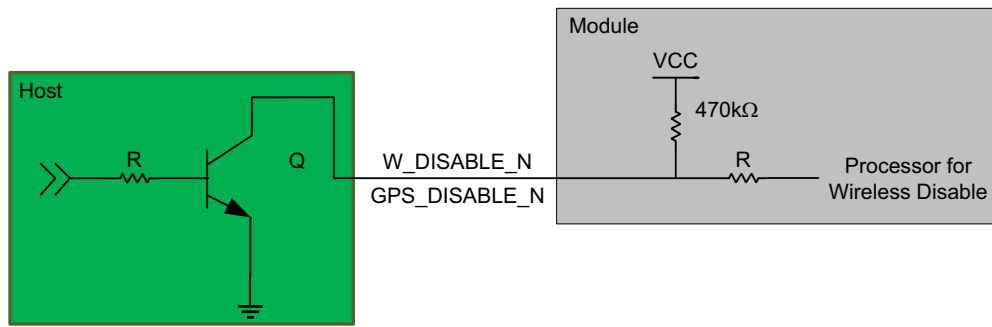

Figure 2-7: Recommended Wireless Disable Connection

2.6.3 Full_Card_Power_Off_N and RESET_N

Note: Host support for Full_Card_Power_Off_N is required, and support for RESET_N is optional.

Full_Card_Power_Off_N and RESET_N are inputs to the module that the host uses as described in Table 2-9.

Table 2-9: Full_Card_Power_Off_N and RESET_N Usage

Name	Pin	Description / notes
Full_Card_Power_Off_N	6	<p>Power the module on/off</p> <ul style="list-style-type: none"> ▪ Signal is required. ▪ Pull HIGH to keep the module on. <p>To keep the module always on, use either of the following methods:</p> <ul style="list-style-type: none"> • Tie the pin directly to a host GPIO (1.8V) • Use an external pull-up to pull the signal high (10kΩ–20kΩ for 1.8V, 75kΩ–100kΩ for VCC rail). Note that a larger-value resistor will reduce leakage current. <ul style="list-style-type: none"> ▪ To power off the module, see Required Shutdown Sequence on page 63. <p><i>Note: The Required Shutdown Sequence on page 63 or the Power On/Off Timing for PCIe Interface on page 61 can be used if the PCIe interface needs to be reinitialized (e.g., because the interface has stalled) and if the host platform is designed to restart PCIe link training. However, if the host platform cannot restart link training or is not responding to Full_Card_Power_Off_N, perform a complete system reset (i.e., reset the host platform). For additional details, see PCIE_PERST_N on page 29.</i></p>

Table 2-9: Full_Card_Power_Off_N and RESET_N Usage (Continued)

Name	Pin	Description / notes
RESET_N	67	<p>Reset the module</p> <p>Note: This signal is required or optional, depending on the power supply:</p> <ul style="list-style-type: none"> Required, if the power supply is not capable of power-cycling the module Optional, if the power supply is capable of power-cycling the module. <p>If the pin is left disconnected on the host, the module will operate correctly since the signal is internally biased.</p> <p>If this signal is connected to the host:</p> <ul style="list-style-type: none"> This is a 'hard' reset, similar to a power cycle. Hard resets should be used only if the host cannot communicate with the module via the PCIe or USB interface and after a reasonable time-out. (If the interface is not working, the module may have locked up or crashed.) To trigger the module reset, assert the RESET_N pin with a logic low signal for a minimum of 450 ms to guarantee a module reset and then release (releasing the signal allows the module to boot). If RESET_N is not released (i.e., it continues to be asserted), the module will remain in the reset state. <p>Note — Sierra Wireless does <u>not</u> recommend using RESET_N to keep the module in the reset state for an extended time period, since the module will continue to draw power while in reset state. Instead, use Full_Card_Power_Off_N to power off the module and then power it back on when needed.</p> <div data-bbox="548 940 1424 1108" style="border: 1px solid black; padding: 5px;"> </div> <ul style="list-style-type: none"> The signal requires an open collector input from the host. <hr/> <p>Caution: RESET_N should not be driven or pulled to a logic high level by the host, as this may cause damage to the module.</p> <hr/> <p>Note: Do not use RESET_N to attempt to reinitialize the PCIe interface (e.g., if the PCIe interface has stalled)—the interface is not hot-plug compatible, so PCIe link training must be restarted, which will not happen with a RESET_N reset. The Required Shutdown Sequence on page 63 or the Power On/Off Timing for PCIe Interface on page 61 can be used if the host platform is designed to restart PCIe link training. However, if the host platform cannot restart link training or is not responding to Full_Card_Power_Off_N, perform a complete system reset (i.e., reset the host platform). For additional details, see PCIE_PERST_N on page 29.</p>

2.6.4 PLA_S2_N (Power Loss Acknowledge)

Note: Host support for PLA_S2_N is optional but highly recommended.

The PLA signal is asserted by the module when it has completed its power down operation. Once asserted, the host can safely remove power to the module.

For timing details, refer to [Timing on page 61](#).

2.6.5 WWAN_LED_N — LED Output

Note: Host support for WWAN_LED_N is optional.

The LED shown in Figure 2-8 flashes in preconfigured on/off patterns to indicate different WWAN states.

WWAN_LED_N supports up to 10 mA current sink.

Contact your Sierra Wireless account representative for details.

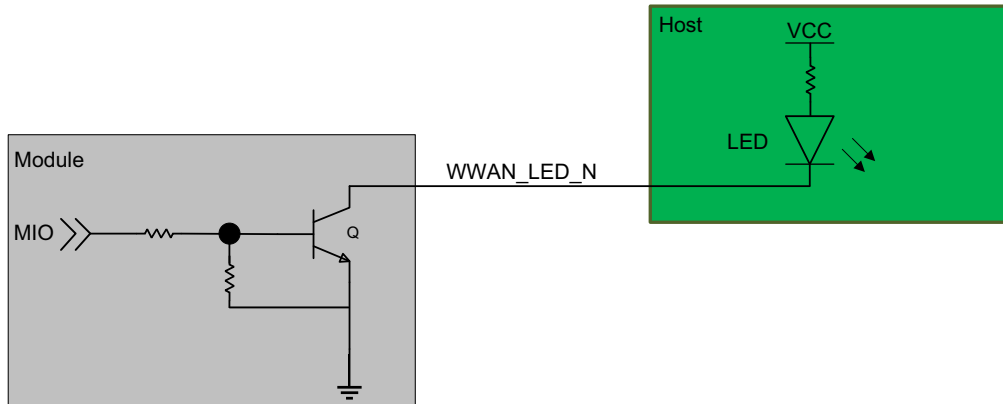

Figure 2-8: Recommended LED Connection

2.7 PCIE_DIS — Interface Selection

Note: Host support for PCIE_DIS is optional — if not connected, the PCIe interface is automatically selected.

The PCIE_DIS signal enables the host platform to select the appropriate host interface (PCIe or USB) and, optionally, to switch between interfaces:

- PCIe single lane interface — Leave the signal unconnected (low) or tie to GND.
- USB interface — Drive the signal high (1.8V).

Switching Interfaces

Typically, a host platform will be designed to use only one of the supported interfaces — PCIe *or* USB (but not both), and will use PCIE_DIS to configure the module as required.

However, if the platform must be able to switch between interfaces (e.g. a development kit that will be used to test both interfaces), the module must be power-cycled or reset to do the switch, because the interfaces are mutually-exclusive.

For example:

- If PCIE_DIS is high ('logic high') when the module boots, the USB interface will be active.
To switch from the USB interface to the PCIe interface:
 - a. While the module is on, set PCIE_DIS low.
At this point, the module continues to use the USB interface.
 - b. While keeping PCIE_DIS low, power cycle the module.
When the module boots, the PCIe interface will be active.

- If PCIE_DIS is low ('logic low') when the module boots, the PCIe interface will be active.
To switch from the PCIe interface to the ISB interface:
 - a. While the module is on, drive PCIE_DIS high.
At this point, the module continues to use the PCIE_DIS interface.
 - b. While keeping PCIE_DIS high, power cycle the module.
When the module boots, the USB interface will be active.

2.8 Tx Power Control

The module's Smart Transmit (ST) exposure scenario (Device State Index (DSI)) may be configured using either of the following methods (selected using the **ICUSTOM** GPIOAREENABLE customization):

- Configure via AT command:
 - !SARSTATE — Set (or report) the current DSI. This setting is non-persistent across power cycles.
 - The module can be set to any defined DSI.
 - For details, refer to [1] *EM9 Series AT Command Reference (Doc# 41113480)*.
- Configure via the DPR (Dynamic Power Reduction) GPIO:
 - The module's firmware monitors DPR (pin 25) with logic as detailed in Table 2-10, and adjusts the RF Tx power for the indicated DSI (exposure scenario). For general details, refer to [11] *EM929x Smart Transmit (Doc# 2174327)*.
 - The module can be set to DSIO or DSI1 via GPIO.
(As noted above, to set to any defined DSI, use the !SARSTATE command.)
 - Note — Change the DSI state away from default (DSIO) only if matching Smart Transmit configuration files are loaded.

Table 2-10: DPR Logic

!SARINTGPIOMODE ^a	DPR Internal Pull	DPR Pin	ST DSI State
0 (default)	Pull-up	High ^b	DSIO
		Low (Active)	DSI1
1	Pull-down	Low	DSIO
		High (Active)	DSI1

a. !SARINTGPIOMODE=1 inverts the DPR logic.

b. The host can implement an open collector drive for the DPR pin (if a 1.8V-compatible driver is not available).

2.9 Antenna Control

Note: Host support for the antenna control signal is optional.

The EM929X module provides the ANT_CTRL0 output GPIO signal (Table 2-11) for use as an indication of B71/n71 usage by host products incorporating a tunable low-band (< 1000 MHz) antenna.

Table 2-11: GPIO Antenna Control Signal

Name	Pin	Description
ANT_CTRL0	59	<p>Output signal indicating B71/n71 use.</p> <p>This signal is asserted (and remains asserted) while any of the following conditions are met:</p> <ul style="list-style-type: none"> ▪ A B71 channel is assigned for Tx ▪ A B71 channel is assigned for Rx (PCC or SCC) ▪ An n71 channel is assigned for Tx ▪ An n71 channel is assigned for Rx (PCC or SCC)

2.10 Module Configuration

The EM929X is an M.2 form factor module configured to Type 3052-S3 (Socket 2 Configuration State #6 (WWAN Key-B: PCIe, USB3, Port Config 2)). This configuration is identified by the pins listed in [Table 2-12](#).

If a host connects these pins to GPIOs on the platform, the pin states (high — NC, low — ground) can be checked to identify the socket configuration.

Table 2-12: Module Configuration Pins

Name	Pin	Description	Type
CONFIG_3	1	Module identification	NC
CONFIG_0	21		Ground
CONFIG_1	69		Ground
CONFIG_2	75		NC

3: RF Specifications

3.1 Antenna Receptacles

EM929X modules include [5G NR Sub-6 GHz/LTE/WCDMA/GNSS Receptacles](#) and (EM9293/EM9293P only) a dedicated GNSS receptacle for use with host-supplied antennas:

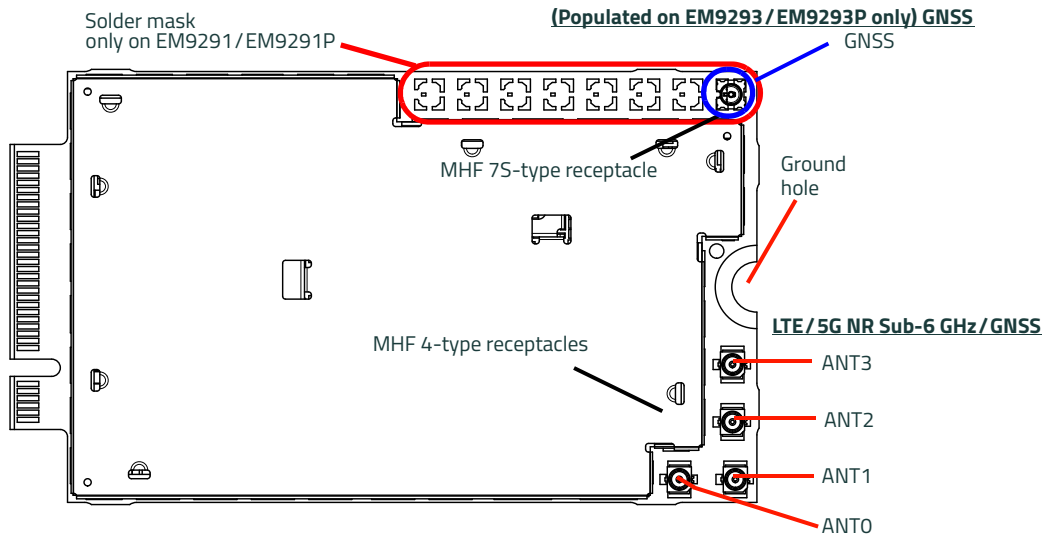

Figure 3-1: EM929X Module RF Receptacles

3.1.1 5G NR Sub-6 GHz/LTE/WCDMA/GNSS Receptacles

The number of 5G NR Sub-6 GHz/LTE/WCDMA/GNSS receptacles is module-dependent.

Table 3-1: 5G NR Sub-6 GHz / LTE/WCDMA / GNSS Receptacles

Module	Receptacles		RATs ^a	Receptacle type ^b
	Qty	Designators		
EM9291	4	ANT0–ANT3	<ul style="list-style-type: none"> 5G NR Sub-6 GHz/LTE/WCDMA on all receptacles ANT1 also supports GNSS 	MHF 4
EM9293	4	ANT0–ANT3	<ul style="list-style-type: none"> 5G NR Sub-6 GHz/LTE/WCDMA on all receptacles ANT1 also supports GNSS 	MHF 4
	1	GNSS	Dedicated GNSS	MHF 7S

a. Refer to [Table 3-2](#) for specific Antenna assignments.

b. To avoid damage when attaching/detaching antenna cables, make sure to use the correct tool for the specific receptacle type (different tools are used for MHF 4 and MHF 7S receptacles) — refer to [Table 1-4](#) for details.

[Table 3-2](#) and [Table 3-3](#) detail the Tx and Rx antenna assignments for 5G NR Sub-6 GHz/LTE/WCDMA/GNSS bands. (Note — The listed Tx antenna assignments are for SA mode.)

Table 3-2: 5G NR Sub-6 GHz / LTE/WCDMA / GNSS Antenna Receptacles — RF Technology Support

RAT ^a	Bands	Tx Antennas ^{b,c,d,e}		Rx Antennas ^f				GNSS Antenna
		Default	Alternate Path ^g	ANT0	ANT1	ANT2	ANT3	(EM9293 / EM9293P only) GNSS
5G NR Sub-6 GHz	29 ⁱ	—	—	Y	—	Y	—	—
	38, 41	ANT2	ANT0	Y	Y	Y	Y	—
	48	ANT3	ANT1	Y	Y	Y	Y	—
	75 ⁱ , 76 ^j	—	—	Y	Y	Y	Y	—
	77, 78	ANT3	ANT1 ANT2	Y	Y	Y	Y	—
	79	ANT3	ANT1	Y	Y	Y	Y	—
LB LTE / 5G NR Sub-6 GHz	5, 8, 12, 13, 14, 17, 18, 19, 20, 26, 28, 71, 106	ANT0	—	Y	—	Y	—	—
MB LTE / 5G NR Sub-6 GHz	1, 2, 3, 4, 7, 25, 30 ^h , 39, 40, 66, 70	ANT0	—	Y	Y	Y	Y	—
LTE	29 ⁱ	—	—	Y	—	Y	—	—
	34 ^j	ANT0	—	Y	—	Y	—	—
	46 ⁱ	—	—	Y	—	—	Y	—
	32 ⁱ	—	—	Y	Y	Y	Y	—
	38, 41	ANT0	—	Y	Y	Y	Y	—
	42, 43	ANT3	—	Y	Y	Y	Y	—
	48	ANT3	ANT1	Y	Y	Y	Y	—
WCDMA	1, 2, 4, 5, 6, 8, 19	ANT0	—	Y	—	Y	—	—
GNSS	L1 ^k /L5	—	—	—	L1 ^k /L5	—	—	L1 ^k

- a. LB=Low Band (<1 GHz), MB=Mid Band (1–2.2 GHz), HB=High Band (2.2–3. GHz), UHB (3–6 GHz)
- b. The indicated Tx antenna is used to carry the Tx PUSCH channel.
- c. SRS antenna switching is supported on certain bands (see [Table 3-4 on page 45](#)).
- d. Tx antenna assignments are for SA mode. For NSA mode, the antenna depends on the RAT, bands and resource allocation, and the device firmware dynamically assigns the antenna based on those factors.
- e. In NSA and ULCA/MIMO modes, a maximum of two Tx antennas can transmit at the same time.
- f. The !DAGFTMRXAGC <path> argument specifies an Rx path (PRx, DRx, MIMO1, MIMO2). See [Table 3-3](#) below for the specific antenna used for the <path> for each band.
- g. Alternate Tx path is used only in ENDC and CA modes. For ENDC and CA, the module firmware chooses the Tx chain (antenna) based on resource allocation.
- h. LTE B30 DL only; n30 DL/UL
- i. DL only band
- j. B34 is restricted to 2x2 by FW (not HW)
- k. GNSS is populated on EM9293/EM9293P only—the EM9293/EM9293P can use either ANT1 or GNSS (software-selectable, ANT1 by default). Note that GNSS is used for GNSS L1 only.

Table 3-3: !DAGFTMRXAGC <path> to Rx Antenna Connector Mapping (Single Band Operation)

!DAGFTMRXAGC <path> value	Antenna function	Band-specific ^{ab} Connector Use (ANT0–ANT3)		
		LB / MB bands		UHB bands
		(All except n38 / n41)	(n38, n41)	(All)
0	PRx	ANT0	ANT2	ANT3
1	MIMO1	ANT1	ANT3	ANT2
2	MIMO2	ANT3	ANT1	ANT1
3	DRx	ANT2	ANT0	ANT0

a. Per [Table 3-2](#).

b. LB=Low Band (<1 GHz), MB=Mid Band (1–2.2 GHz), HB=High Band (2.2–3. GHz), UHB (3–6 GHz)

3.2 RF Connections

When attaching antennas to the module:

- LTE/5G NR Sub-6 GHz/GNSS receptacles (ANT0–ANT3):
 - Use RF plugs that are compatible with I-PEX (20449-001E (MHF 4)) RF receptacles.
 - Match coaxial connections between the module and the antenna to 50 Ω.
 - Minimize RF cable losses to the antenna; the recommended maximum cable loss for antenna cabling is 0.5 dB.
- (EM9293/EM9293P only) Dedicated GNSS receptacle (GNSS):
 - Use only an RF plug connector that is compatible with I-PEX (20981-001E-02 (MHF 7S)) RF receptacles.
- To ensure best thermal performance, use the ground hole (if possible) to attach (ground) the device to a metal chassis.

Important: *Systems connected to a live network must have all four MHF 4 antennas (ANT0–ANT3) connected. (The dedicated GNSS antenna (GNSS) is only required if the dedicated GNSS antenna path is configured.)*

Note: If an antenna connection is shorted or open, the modem will not sustain permanent damage.

3.2.1 5G NR Sub-6 GHz/GNSS Antennas and Cabling

When selecting 5G NR Sub-6 GHz/GNSS antennas and cables, it is critical to RF performance to match antenna gain and cable loss.

Note: There is no explicit list of antennas required in the host platform. The PWB-6-60-RSMAP Wide Band 4G/5G Terminal Paddle Antenna has been verified as a reference. For detailed electrical performance criteria, see [Appendix A: Antenna Specification](#) on page 82.

3.2.1.1 Choosing the Correct 5G NR Sub-6 GHz/GNSS Antenna and Cabling

When matching antennas and cabling:

- The antenna (and associated circuitry) should have a nominal impedance of 50 Ω with a return loss of better than 10 dB across each frequency band of operation.
- The system gain value affects both radiated power and regulatory (FCC, IC, CE, etc.) test results.

3.2.1.2 Determining the 5G NR Sub-6 GHz / GNSS Antenna's Location

When deciding where to put the antennas:

- Antenna location may affect RF performance. Although the module is shielded to prevent interference in most host platforms, the placement of the antenna is still very important — if the host platform is insufficiently shielded, high levels of broadband or spurious noise can degrade the module's performance.
- Connecting cables between the module and the antenna must have 50 Ω impedance. If the impedance of the module is mismatched, RF performance is reduced significantly.
- Antenna cables should be routed, if possible, away from noise sources (switching power supplies, LCD assemblies, etc.). If the cables are near the noise sources, the noise may be coupled into the RF cable and into the antenna. See [Interference from Other Wireless Devices on page 44](#).

3.2.1.3 Disabling the Diversity Antenna

Certification testing of a device with an integrated EM929X module may require the module's main and diversity antennas to be tested separately.

Note: For WCDMA, the diversity antenna is ANT2. For LTE and 5G, the diversity antenna will be ANTO–ANT3, dependent on the band combination. For example, some combinations may use ANTO, some may use ANT1, etc.

To facilitate this testing, receive diversity can be enabled / disabled using the following AT command:

- `!RXDEN` — Used to enable / disable diversity for single-cell call (no carrier aggregation).
For details, refer to [1] *EM9 Series AT Command Reference (Doc# 41113480)*.

Important: *Systems connected to a live network must have all four MHF 4 antennas (ANTO–ANT3) connected. (The dedicated GNSS antenna (GNSS) is only required if the dedicated GNSS antenna path is configured.)*

Note: A diversity antenna is used to improve connection quality and reliability through redundancy. Because two antennas may experience different interference effects (signal distortion, delay, etc.), when one antenna receives a degraded signal, the other may not be similarly affected.

3.3 Shielding

The module is fully shielded to protect against EMI. The shield must not be removed.

3.4 Ground Connection

When connecting the module to system ground:

- Prevent noise leakage by establishing a very good ground connection to the module through the host connector.
- Connect to system ground using the ground hole shown in [Figure 3-1 on page 40](#).
- Minimize ground noise leakage into the RF.
Depending on the host board design, noise could potentially be coupled to the module from the host board. This is mainly an issue for host designs that have signals traveling along the length of the module, or circuitry operating at both ends of the module interconnects.

3.5 Interference and Sensitivity

Several interference sources can affect the module's RF performance (RF desense). Common sources include power supply noise and device-generated RF.

RF desense can be addressed through a combination of mitigation techniques ([Methods to Mitigate Decreased Rx Performance on page 44](#)) and radiated sensitivity measurement ([Radiated Sensitivity Measurement on page 45](#)).

3.5.1 Interference from Other Wireless Devices

Wireless devices operating inside the host device can cause interference that affects the module.

To determine the most suitable locations for antennas on your host device, evaluate each wireless device's radio system, considering the following:

- Any harmonics, sub-harmonics, or cross-products of signals generated by wireless devices that fall in the module's Rx range may cause spurious response, resulting in decreased Rx performance.
- The Tx power and corresponding broadband noise of other wireless devices may overload or increase the noise floor of the module's receiver, resulting in Rx desense.

The severity of this interference depends on the closeness of the other antennas to the module's antenna. To determine suitable locations for each wireless device's antenna, thoroughly evaluate your host device's design.

3.5.2 Host-generated RF Interference

All electronic computing devices generate RF interference that can negatively affect the receive sensitivity of the module.

Proximity of host electronics to the antenna in wireless devices can contribute to decreased Rx performance. Components that are most likely to cause this include:

- Microprocessor and memory
- Display panel and display drivers
- Switching-mode power supplies

3.5.3 Device-generated RF Interference

The module can cause interference with other devices. Wireless devices such as Sierra Wireless embedded modules transmit in bursts (pulse transients) for set durations (RF burst frequencies). Hearing aids and speakers convert these burst frequencies into audible frequencies, resulting in audible noise.

3.5.4 Methods to Mitigate Decreased Rx Performance

It is important to investigate sources of localized interference early in the design cycle. To reduce the effect of device-generated RF on Rx performance:

- Put the antenna as far as possible from sources of interference. The drawback is that the module may be less convenient to use.
- Shield the host device. The module itself is well shielded to avoid external interference. However, the antenna cannot be shielded for obvious reasons. In most instances, it is necessary to employ shielding on the components of the host device (such as the main processor and parallel bus) that have the highest RF emissions.
- Filter out unwanted high-order harmonic energy by using discrete filtering on low frequency lines.
- Form shielding layers around high-speed clock traces by using multi-layer PCBs.
- Route antenna cables away from noise sources.

3.5.5 Radiated Spurious Emissions (RSE)

When designing an antenna for use with Sierra Wireless embedded modules, the host device with an Sierra Wireless embedded module must satisfy any applicable standards/local regulatory bodies for radiated spurious emission (RSE) for receive-only mode and for transmit mode (transmitter is operating).

Note that antenna impedance affects radiated emissions, which must be compared against the conducted 50 Ω emissions baseline. (Sierra Wireless embedded modules meet the 50 Ω conducted emissions requirement.)

3.6 Radiated Sensitivity Measurement

A wireless host device contains many noise sources that contribute to a reduction in Rx performance.

Over-the-air (OTA) or radiated testing is done to determine the extent of any receiver performance desensitization due to self-generated noise in the host device. Receiver desensitization can show up as lower than expected radiated resistivity measurements.

3.6.1 Sensitivity vs. Frequency

Sensitivity definitions for supported RATs:

- UMTS bands — Sensitivity is defined as the input power level in dBm that produces a BER (Bit Error Rate) of 0.1%. Sensitivity should be measured at all UMTS frequencies across each band.
- LTE bands — Sensitivity is defined as the RF level at which throughput is 95% of maximum.
- 5G NR Sub-6 GHz bands — Sensitivity is defined as the RF level at which throughput is 95% of maximum.

3.7 Sounding Reference Signal

The EM929X implements a Sounding Reference Signal (SRS) on specific 5G NR Sub-6 GHz bands ([Table 3-4](#)).

An SRS is an uplink reference signal that the UE transmits to the base station. This signal provides channel 'sounding' information (details about the uplink signal) that the base station uses to estimate the combined effect on uplink channel quality, including multipath fading, scattering, Doppler, and power loss.

Based on the channel quality, the base station can manage resource scheduling, beam management, and signal power control.

SRS can also implement antenna switching on the EM929X by sending sequential SRS bursts on different device antennas. The base station analyzes the bursts, then indicates to the module which antennas are providing the best channel quality, and system performance is adjusted appropriately.

Table 3-4: SRS 5G NR Sub-6 GHz Band Support

SRS type	Band							Notes
	n38	n40	n41	n48	n77	n78	n79	
SRS_T1_R4 ^a	Y	Y	Y	Y	Y	Y	Y	T1_R4 is supported only on single UL combinations.
SRS_T2_R4 ^b	Y	—	Y	Y	Y	Y	Y	On UL MIMO combinations with two ULs, only T2_R4 will be signaled.

a. 1 Tx + 4 Rx

b. 2 Tx + 4 Rx

3.8 Supported RATs

The EM929X module supports:

- 5G:
 - Multiple-band 5G — See [Table 3-5](#) (supported bands) and [Table 3-7](#) (5G NR bandwidth support).
 - 5G NR Carrier aggregation:
 - 5G NR Sub-6 GHz DLCA (SA and NSA EN-DC) — Up to 3CC intra-band and inter-band CA combinations
 - 5G NR Sub-6 GHz ULCA (SA) — Specific 2CC inter-band CA combinations (n78+n1, n78+n3, n78+n5, n78+n8, n79+n28; n41+n28 (TBC)) where the PC1.5-capable component (band) is limited to PC2 operation. ULCA SA does not support PC1.5 operation.
 - For comprehensive details including supported CA combinations, refer to *[15] EM9 Carrier Aggregations and EN-DC (Doc# 2174317)*.
- LTE:
 - Multiple-band LTE — See [Table 3-5](#) (supported bands) and [Table 3-6 on page 47](#) (LTE bandwidth support).
 - LTE Advanced carrier aggregation:
 - Intra-band contiguous and non-contiguous ULCA
 - Inter-band ULCA — Low band and mid-high band combinations.
 - For comprehensive details including supported CA combinations, refer to *[15] EM9 Carrier Aggregations and EN-DC (Doc# 2174317)*.
- WCDMA:
 - Multiple-band WCDMA/HSPA/HSPA+/DC-HSPA+ — See [Table 3-5](#).
 - Multiple-band WCDMA receive diversity
- [inter-RAT](#) and inter-frequency cell reselection and handover between supported frequency bands
- GNSS:
 - GPS, GLONASS, BeiDou, Galileo, QZSS, NavIC — See [Table 3-12 on page 54](#).

3.8.1 Supported Bands

Table 3-5: Supported Frequency Bands, by RAT (5G NR/LTE/3G)

Band#	Mode	5G (n<band#)	LTE (B<band#>)	3G (Band<band#)	Frequency (Tx)	Frequency (Rx)
1	FDD	Y	Y	Y	1920–1980 MHz	2110–2170 MHz
2	FDD	Y	Y	Y	1850–1910 MHz	1930–1990 MHz
3	FDD	Y	Y	—	1710–1785 MHz	1805–1880 MHz
4	FDD	—	Y	Y	1710–1755 MHz	2110–2155 MHz
5	FDD	Y	Y	Y	824–849 MHz	869–894 MHz
6	FDD	—	—	Y	830–840 MHz	875–885 MHz
7	FDD	Y	Y	—	2500–2570 MHz	2620–2690 MHz
8	FDD	Y	Y	Y	880–915 MHz	925–960 MHz
12	FDD	Y	Y	—	699–716 MHz	729–746 MHz
13	FDD	Y	Y	—	777–787 MHz	746–756 MHz
14	FDD	Y	Y	—	788–798 MHz	758–768 MHz
17	FDD	—	Y	—	704–716 MHz	734–746 MHz
18	FDD	Y	Y	—	815–830 MHz	860–875 MHz

Table 3-5: Supported Frequency Bands, by RAT (5G NR/LTE/3G) (Continued)

Band#	Mode	5G (n<band#)	LTE (B<band#>)	3G (Band<band#)	Frequency (Tx)	Frequency (Rx)
19	FDD	—	Y	Y	830–845 MHz	875–890 MHz
20	FDD	Y	Y	—	832–862 MHz	791–821 MHz
25	FDD	Y	Y	—	1850–1915 MHz	1930–1995 MHz
26	FDD	Y	Y	—	814–849 MHz	859–894 MHz
28	FDD	Y	Y	—	703–748 MHz	758–803 MHz
29	SDL	Y	Y	—	n/a	717–728 MHz
30	FDD	Y	Y	—	n30: 2305–2315 MHz B30: n/a ^a	2350–2360 MHz
32	SDL	—	Y	—	n/a	1452–1496 MHz
34	TDD	—	Y	—	2010–2025 MHz (TDD)	
38	TDD	Y	Y	—	2570–2620 MHz (TDD)	
39	TDD	—	Y	—	1880–1920 MHz (TDD)	
40	TDD	Y	Y	—	2300–2400 MHz (TDD)	
41	TDD	Y	Y	—	2496–2690 MHz (TDD)	
42	TDD	—	Y	—	3400–3600 MHz (TDD)	
43	TDD	—	Y	—	3600–3800 MHz (TDD)	
46 ^b	TDD	—	Y	—	n/a	5150–5925 MHz (TDD)
48	TDD	Y	Y	—	3550–3700 MHz (TDD)	
66	FDD	Y	Y	—	1710–1780 MHz	2110–2200 MHz
70	FDD	Y	—	—	1695–1710 MHz	1995–2020 MHz
71	FDD	Y	Y	—	663–698 MHz	617–652 MHz
75	SDL	Y	—	—	n/a	1432–1517 MHz
76	SDL	Y	—	—	n/a	1427–1432 MHz
77	TDD	Y	—	—	3300–4200 MHz (TDD)	
78	TDD	Y	—	—	3300–3800 MHz (TDD)	
79	TDD	Y	—	—	4400–5000 MHz (TDD)	
106	FDD	—	Y	—	896–901 MHz	935–940 MHz

a. LTE B30 downlink only

b. LTE-LAA B46 (downlink only)

Table 3-6: LTE Bandwidth Support^{ab}

Band	1.4 MHz	3 MHz	5 MHz	10 MHz	15 MHz	20 MHz
B1	—	—	Y	Y	Y	Y
B2	Y	Y	Y	Y	Y ^c	Y ^c

Table 3-6: LTE Bandwidth Support^{ab} (Continued)

Band	1.4 MHz	3 MHz	5 MHz	10 MHz	15 MHz	20 MHz
B3	Y	Y	Y	Y	Y ^c	Y ^c
B4	Y	Y	Y	Y	Y	Y
B5	Y	Y	Y	Y ^c	—	—
B7	—	—	Y	Y	Y ^d	Y ^{c,d}
B8	Y	Y	Y	Y ^c	—	—
B12	Y	Y	Y ^c	Y ^c	—	—
B13	—	—	Y ^c	Y ^c	—	—
B14	—	—	Y ^c	Y ^c	—	—
B17	—	—	Y ^c	Y ^c	—	—
B18	—	—	Y	Y ^c	Y ^c	—
B19	—	—	Y	Y ^c	Y ^c	—
B20	—	—	Y	Y ^c	Y ^c	Y ^c
B25	Y	Y	Y	Y	Y ^c	Y ^c
B26	Y	Y	Y	Y ^c	Y ^c	—
B28	—	Y	Y	Y ^c	Y ^c	Y ^{c,e}
B29	—	Y	Y	Y ^c	—	—
B30 ^f	—	—	Y	Y ^c	—	—
B32	—	—	Y	Y	Y	Y
B34	—	—	Y	Y	Y	—
B38	—	—	Y	Y	Y ^d	Y ^d
B39	—	—	Y	Y	Y ^d	Y ^d
B40	—	—	Y	Y	Y	Y
B41	—	—	Y	Y	Y	Y
B42	—	—	Y	Y	Y	Y
B43	—	—	Y	Y	Y	Y
B46 ^g	—	—	—	Y	—	Y
B48	—	—	Y	Y	Y	Y
B66	Y	Y	Y	Y	Y	Y
B71	—	—	Y	Y ^c	Y ^c	Y ^{c,h}
B106	Y	Y	—	—	—	—

- a. Support provided by module hardware/firmware. Carrier PRI configurations and regulatory body requirements may limit the supported bandwidths in customer applications.
- b. Table contents are derived from 3GPP TS 36.521-1 v15.5.0, table 5.4.2.1-1.
- c. Bandwidth for which a relaxation of the specified UE receiver sensitivity requirement (Clause 7.3 of 3GPP TS 36.521-1 v15.5.0) is allowed.

- d. Bandwidth for which uplink transmission bandwidth can be restricted by the network for some channel assignments in FDD/TDD co-existence scenarios in order to meet unwanted emissions requirements (Clause 6.6.3.2 of 3GPP TS 36.521-1 v15.5.0).
- e. For the 20 MHz bandwidth, the minimum requirements are specified for EUTRA UL carrier frequencies confined to either 713–723 MHz or 728–738 MHz.
- f. DL only
- g. LTE-LAA B46 (downlink only), used only in LTE CA
- h. For the 20 MHz bandwidth, the minimum requirements are specified for EUTRA UL carrier frequencies confined to either 673–678 MHz or 683–688 MHz.

Table 3-7: 5G NR Bandwidth and 5G Architecture Support

Band	SCS	Bandwidth (MHz) (Default architecture support: N — Non-Standalone; S — Standalone; B — Both (N+S))													
		5	10	15	20	25	30	35	40	50	60	70	80	90	100
n1	15	B	B	B	B	B	B	—	B	—	—	—	—	—	—
n2	15	B	B	B	B	—	—	—	—	—	—	—	—	—	—
n3	15	B	B	B	B	B	B	—	B ^a	—	—	—	—	—	—
n5	15	B	B	B	B	B ^b	—	—	—	—	—	—	—	—	—
n7	15	B	B	B	B	B	B	—	B	—	—	—	—	—	—
n8	15	B	B	B	B	—	—	B ^b	—	—	—	—	—	—	—
n12	15	B	B	B	—	—	—	—	—	—	—	—	—	—	—
n13	15	S	S	—	—	—	—	—	—	—	—	—	—	—	—
n14	15	B	B	—	—	—	—	—	—	—	—	—	—	—	—
n18	15	S	S	S	—	—	—	—	—	—	—	—	—	—	—
n20	15	B	B	B	B	—	—	—	—	—	—	—	—	—	—
n25	15	B	B	B	B	B	B	—	B	—	—	—	—	—	—
n26	15	S	S	S	S	—	—	—	—	—	—	—	—	—	—
n28	15	B	B	B	B	—	B	—	—	—	—	—	—	—	—
n29	15	B ^b	B ^b	—	—	—	—	—	—	—	—	—	—	—	—
n30	15	B	B	—	—	—	—	—	—	—	—	—	—	—	—
n38	30	—	B	B	B	—	B	—	B	—	—	—	—	—	—
n40	30	—	B	B	B	—	B	—	B	B	B	—	B	B ^b	B ^b
n41 ^c	30	—	B	B	B	—	B	—	B	$\begin{matrix} S \\ N^d \end{matrix}$	$\begin{matrix} S \\ N^d \end{matrix}$	—	$\begin{matrix} S \\ N^d \end{matrix}$	$\begin{matrix} S \\ N^d \end{matrix}$	$\begin{matrix} S \\ N^d \end{matrix}$
n48	30	—	B	B	B	—	B	—	B	B ^b	B ^b	—	B ^b	B ^b	B ^b
n66	15	B	B	B	B	B	B	—	B	—	—	—	—	—	—
n70	15	S	S	S	S ^b	S ^b	—	—	—	—	—	—	—	—	—
n71	15	B	B	B	B	B ^b	B ^b	B ^b	—	—	—	—	—	—	—
n75	15	B ^b	B ^b	B ^b	B ^b	B ^{b,a}	B ^{b,a}	—	—	—	—	—	—	—	—
n76	15	B ^b	—	—	—	—	—	—	—	—	—	—	—	—	—
n77	30	—	B	B	B	—	B	—	B	B	B	B	B	B	B
n78	30	—	B	B	B	—	B	—	B	B	B	B	B	B	B

Table 3-7: 5G NR Bandwidth and 5G Architecture Support (Continued)

Band	SCS	Bandwidth (MHz) (Default architecture support: N — Non-Standalone; S — Standalone; B — Both (N+S))													
		5	10	15	20	25	30	35	40	50	60	70	80	90	100
n79	30	—	—	—	—	—	—	—	B	B	B	—	B	—	B

- a. non-3GPP BW (3GPP TS 38.521-1 V17.4.0 (2022-03))
- b. DL only
- c. n41 BW support:
 - UL — Up to 40 MHz (ENDC/UL MIMO mode) or 100 MHz (5G NR SA mode)
 - DL — Up to 100 MHz
- d. DL only in ENDC/UL MIMO mode

3.8.2 CA/EN-DC Support

For comprehensive LTE CA and 5G NR EN-DC support details (including UL and DL combinations), refer to [15] *EM9 Carrier Aggregations and EN-DC (Doc# 2174317)*.

Note — 5G NR Inter-band UL CA is not currently supported.

3.9 Conducted Rx Sensitivity / Tx Power

Table 3-8: Typical Conducted Rx Sensitivity — 5G NR Sub-6 GHz Bands

Band	Duplex Mode	SCS (KHz)	BW (MHz)	Antennas for RX0-RX3	Typical Conducted Rx Sensitivity (dBm) ^{ab}						Worst Case (dBm) ^c			
					RX0	RX1	RX2	RX3	2 Rx	4 Rx	2 Rx Limit	2 Rx Margin	4 Rx Limit	4 Rx Margin
n1	FDD	15	20	0,2,1,3	-95.7	-95.4	-97.0	-96.6	-98.0	-100.5	-93.1	4.9	-95.8	4.7
n2	FDD	15	20	0,2,1,3	-96.3	-95.4	-96.4	-97.0	-99.0	-101.0	-91.1	7.9	-93.8	7.2
n3	FDD	15	20	0,2,1,3	-96.5	-96.2	-96.9	-97.5	-99.0	-101.5	-90.1	8.9	-92.8	8.7
n5	FDD	15	20	0,2,-,-	-97.5	-99.0	-	-	-99.5	-	-90.1	9.4	-	-
n7	FDD	15	20	0,2,1,3	-96.1	-94.0	-95.7	-95.3	-98.5	-99.5	-91.1	7.4	-93.8	5.7
n8	FDD	15	20	0,2,-,-	-97.5	-98.9	-	-	-99.5	-	-89.3	10.2	-	-
n12	FDD	15	15	0,2,-,-	-98.9	-100.5	-	-	-101.0	-	-83.3	17.7	-	-
n13	FDD	15	5	0,2,-,-	-103.6	-104.8	-	-	-107.3	-	-96.3	11.0	-	-
n14	FDD	15	5	0,2,-,-	-103.9	-104.8	-	-	-106.5	-	-96.3	10.2	-	-
n18	FDD	15	15	0,2,-,-	-100.5	-102.0	-	-	-102.5	-	-94.3	8.2	-	-
n20	FDD	15	20	0,2,-,-	-97.6	-99.2	-	-	-99.5	-	-89.1	10.4	-	-
n25	FDD	15	20	0,2,1,3	-96.2	-95.3	-96.3	-96.9	-99.0	-100.5	-89.6	9.4	-92.3 ^d	8.2
n26	FDD	15	20	0,2,-,-	-97.7	-99.0	-	-	-100.0	-	-86.9	13.1	-	-
n28	FDD	15	20	0,2,-,-	-97.4	-99.0	-	-	-99.5	-	-90.1	9.4	-	-
n29	SDL	15	5	0,2,-,-	-103.6	-104.6	-	-	-107.1	-	-97.0	10.1	-	-
n30	FDD	15	5	0,2,1,3	-99.3	-101.5	-100.4	-101.3	-102.3	-105.8	-98.3	4.0	-101.0	4.8

Table 3-8: Typical Conducted Rx Sensitivity — 5G NR Sub-6 GHz Bands (Continued)

Band	Duplex Mode	SCS (KHz)	BW (MHz)	Antennas for RX0–RX3	Typical Conducted Rx Sensitivity (dBm) ^{ab}						Worst Case (dBm) ^c			
					RX0	RX1	RX2	RX3	2 Rx	4 Rx	2 Rx Limit	2 Rx Margin	4 Rx Limit	4 Rx Margin
n38	TDD	30	20	2,0,3,1	-94.2	-95.7	-95.7	-93.6	-96.4	-98.9	-93.1	3.3	-96.0	2.9
n40	TDD	30	20	0,2,1,3	-96.9	-95.2	-96.4	-96.3	-99.1	-102.3	-93.3	5.8	-96.0	6.3
n41	TDD	30	20	2,0,3,1	-93.7	-95.3	-95.2	-93.5	-95.8	-98.6	-91.3	4.5	-94.0	4.6
n48	TDD	30	20	3,0,2,1	-97.4	-92.5	-95.5	-95.6	-92.4	-99.1	-91.9	0.5	-94.1	5.0
n66	FDD	15	20	0,2,1,3	-95.5	-95.3	-96.7	-96.2	-98.0	-100.5	-92.6	5.4	-95.3	5.2
n70	FDD	15	5	0,2,1,3	-102.3	-100.9	-101.7	-102.4	-104.6	-107.9	-99.3	5.3	-102.0	5.9
n71	FDD	15	20	0,2,-,-	-97.3	-98.6	-	-	-99.5	-	-85.3	14.2	-	-
n75	SDL	15	10	0,2,1,3	-95.9	-97.4	-99.2	-99.7	-99.7	-104.3	-96.8	2.9	-99.5	4.8
n76	SDL	15	5	0,2,1,3	-98.6	-99.6	-101.7	-102.4	-102.1	-106.9	-100.0	2.1	-102.7	4.2
n77	TDD	30	100	3,0,2,1	-89.7	-85.6	-88.2	-88.2	-86.1	-90.1	-84.5	1.5	-86.7	3.3
n78	TDD	30	100	3,0,2,1	-89.9	-85.8	-88.5	-87.9	-86.3	-90.1	-84.5	1.8	-86.7	3.4
n79	TDD	30	100	3,0,2,1	-87.4	-86.9	-88.2	-89.5	-89.6	-90.8	-84.5	5.0	-86.7	4.0

- a. Results at room temperature. Based on Lab test result and Call box only in a shielded test environment. There might be MSD for the cases which has harmonic and IMD exceptions, we guarantee better performance than the level that 3GPP defined.
- b. RX0–RX3 values are SISO measurements. 2Rx and 4Rx values are derived from the RX0–RX3 SISO measurements.
- c. Per 3GPP specification
- d. 3GPP does not specify a 4 Rx limit for band n25. The suggested limit applies the reference sensitivity allowance (-2.7) specified for band n2.

Table 3-9: Typical Conducted Rx Sensitivity — LTE Bands at 10 MHz BW^{a b}

Band	Antennas for RX0–RX3	Typical Conducted Rx sensitivity (dBm) ^{c d}						3GPP Limit (dBm)		Margin
		RX0	RX1	RX2	RX3	PRx+DRx	4 Rx	PRx+DRx	4 Rx	
B1	0,2,1,3	-97.6	-97.8	-99.5	-99.1	-	-104.0	-	-99.0	5.0
B2	0,2,1,3	-98.4	-96.9	-98.5	-99.0	-	-103.6	-	-97.0	6.6
B3	0,2,1,3	-98.5	-97.5	-99.1	-99.5	-	-104.2	-	-96.0	8.2
B4	0,2,1,3	-97.8	-97.5	-98.8	-98.9	-	-103.8	-	-99.0	4.8
B5	0,2,-,-	-99.8	-101.2	-	-	-103.3	-	-94.3	-	9.0
B7	0,2,1,3	-97.6	-95.7	-97.9	-97.6	-	-102.5	-	-97.0	5.5
B8	0,2,-,-	-99.2	-100.6	-	-	-102.6	-	-93.3	-	9.3
B12	0,2,-,-	-99.9	-101.4	-	-	-103.4	-	-93.3	-	10.1
B13	0,2,-,-	-100.0	-101.2	-	-	-103.5	-	-93.3	-	10.2
B14	0,2,-,-	-100.1	-101.0	-	-	-103.4	-	-93.3	-	10.1
B17	0,2,-,-	-99.9	-101.4	-	-	-103.4	-	-93.3	-	10.1
B18	0,2,-,-	-99.7	-101.4	-	-	-103.3	-	-96.3	-	7.0

Table 3-9: Typical Conducted Rx Sensitivity — LTE Bands at 10 MHz BW^{a,b} (Continued)

Band	Antennas for RX0–RX3	Typical Conducted Rx sensitivity (dBm) ^{c,d}						3GPP Limit (dBm)		Margin
		RX0	RX1	RX2	RX3	PRx+DRx	4 Rx	PRx+DRx	4 Rx	
B19	0,2,-,-	-99.9	-101.1	-	-	-103.3	-	-96.3	-	7.0
B20	0,2,-,-	-99.5	-101.0	-	-	-103.1	—	-96.3 ^e	—	6.8
B25	0,2,1,3	-98.4	-96.7	-98.4	-98.9	-	-103.6	-	-95.5	8.1
B26	0,2,-,-	-99.8	-101.3	-	-	-103.3	-	-94.5	-	9.0
B28	0,2,-,-	-99.4	-100.9	-	-	-103.0	-	-94.8	-	8.2
B29	0,2,-,-	-100.5	-101.0	-	-	-103.5	-	-93.3	-	10.2
B30	0,2,1,3	-96.1	-98.5	-	-	-103.1	-	-95.3	-	7.8
B32	0,2,1,3	-97.0	-98.7	-100.5	-101.0	-	-104.5	-96.3	-	8.2
B34	0,2,-,-	-99.1	-99.2	-	-	-101.8	-	-96.3	-	5.5
B38	0,2,1,3	-98.0	-95.8	-98.2	-97.8	-	-102.2	-	-99.0 ^f	3.2
B39	0,2,1,3	-98.4	-97.8	-99.5	-99.9	-	-103.9	-	-99.0	4.9
B40	0,2,1,3	-102.5	-100.7	-102.2	-101.1	-	-106.8	-	-99.0	7.8
B41	0,2,1,3	-97.5	-95.3	-97.5	-97.0	-	-101.6	-	-97.0	4.6
B42	3,0,2,1	-98.7	-98.7	-99.4	-99.3	-	-104.0	-	-97.2	6.8
B43	3,0,2,1	-98.3	-99.0	-99.8	-99.1	-	-103.8	-	-97.7 ^f	6.6
B46 ^a	0,3,-,-	-94.0	-94.5	-	-	-96.5	-	-91.5	-	5.0
B48	3,0,2,1	-98.7	-99.1	-100.1	-99.3	-	-104.4	-	-98.0 ^f	7.2
B66	0,2,1,3	-97.7	-97.6	-99.3	-98.8	-	-103.8	-	-98.5	5.3
B71	0,2,-,-	-99.7	-101.2	-	-	-103.3	-	-93.5	-	9.8
B106 ^b	0,2,-,-	-104.2	-105.5	-	-	-107.5	-	-99.2	-	8.3

- a. B46 BW=20 MHz
- b. B106 BW=3 MHz
- c. Sensitivity values scale with bandwidth: $x_MHz_Sensitivity = 10_MHz_Sensitivity - 10 \cdot \log(10\text{ MHz}/x_MHz)$ Note: Bandwidth support is dependent on firmware version.
- d. Results at room temperature. Based on Lab test result and Call box only in a shielded test environment, and the test is based on standalone mode only.
- e. B20—3GPP 4Rx limit used for PRx+DRx, since 4 Rx is not supported by the EM929X.
- f. 3GPP does not specify 4 Rx limits for bands B38, B43, and B48. The suggested limit applies the reference sensitivity allowance from 2 Rx to 4 Rx of -2.7 dB.

Table 3-10: Typical^a Conducted Rx Sensitivity — UMTS Bands

UMTS bands ^b	Conducted Rx sensitivity (dBm)			3GPP Limit (dB)	Margin (dB)
	ANT0 (PRx)	ANT2 (DRx)	PRx+DRx		
Band 1	-109.6	-109.6	-112.4	-106.0	6.4
Band 2	-110.9	-110.8	-112.6	-104.0	8.6

Table 3-10: Typical^a Conducted Rx Sensitivity — UMTS Bands (Continued)

UMTS bands ^b	Conducted Rx sensitivity (dBm)			3GPP Limit (dB)	Margin (dB)
	ANT0 (PRx)	ANT2 (DRx)	PRx+DRx		
Band 4	-111.1	-111.3	-114.5	-106.0	8.5
Band 5	-112.3	-112.4	-116.0	-104.0	12.0
Band 6	-112.3	-112.4	-116.0	-106.0	10
Band 8	-114.7	-114.5	-115.9	-103.0	12.9
Band 19	-112.3	-112.4	-116.0	-106.0	10

- a. The typical result is at room temperature and based on Lab test result and Call box only at a shielded test environment.
- b. Measurement at 0.1% BER, 12.2 kbps

Table 3-11: Conducted Maximum Tx Power Tolerances

Bands	Conducted Tx Power ^{a,b,c}	Notes
5G		
n41, n77, n78, n79	+29 dBm ±1.5 dB	(EM9291P/EM9293P only) Power Class 1.5 (HPUE) operation
	+26 dBm +1.5/-2.0 dB	Power Class 2 (HPUE) operation
	+24 dBm +1.5/-2.0 dB	Power Class 3 operation
n1, n2, n3, n5, n7, n8, n12, n13, n14, n18, n20, n25, n26, n28, n30, n38, n40, n48, n66, n70, n71	+24 dBm +1.5/-2.0 dB	Power Class 3 ^d
LTE		
B41 HPUE B42 HPUE B43 HPUE	+25 dBm ± 1.0 dB	<ul style="list-style-type: none"> ▪ Power Class 2 (HPUE) in LTE-only mode <i>Note: For B41 ULCA combinations, only B41C and B41D support power class 2. All other B41 ULCA combinations are power class 3.</i> ▪ Power Class 3 in NSA mode (i.e, when the band is part of an ENDC combination)
B41	+23 dBm ± 1.0 dB	Power Class 3 <i>Note: B41C and B41D ULCA combinations are power class 2 (see the row above). All other B41 ULCA combinations are power class 3.</i>
B2, B4, B5, B13, B66	+23.5 dBm ± 1.0 dB	Power Class 3 Max Power provides additional margin for Verizon Lab Conformance testing.
All other LTE bands	+23 dBm ± 1.0 dB	Power Class 3 ^d
UMTS		
All UMTS bands (12.2 kbps)	+23.5 dBm ± 1 dB	Power Class 3

- a. Tx Power is based on no maximum power reduction (MPR) configuration as 3GPP defined. For configurations that require MPR or additional MPR, refer to 3GPP for the power reduction.

- b. For EN-DC and 5G NR UL CA, the maximum power is the maximum of the component carriers (i.e., CC1 and CC2). For example, if CC1 is power class 3 and CC2 is power class 2, the maximum will be power class 2.
- c. For intra-band contiguous LTE UL CA bandwidth class C with non-contiguous resource block (RB) allocation, a maximum power reduction (MPR) of up to 8.5 dB is applied, per 3GPP TS 36.521-1 section 6.2.3A.1.
- d. Depending on the host platform antenna design, the maximum Tx power of bands B48, n30 and n48 may need to be reduced by the platform vendor to meet FCC EIRP limits.

3.10 GNSS Specifications

Note: For detailed electrical performance criteria, see [Recommended GNSS Antenna Specifications on page 84](#).

Table 3-12: GNSS Specifications

Parameter/feature		Description
Satellite channels		Support all in-view satellites (L1 + L5) for simultaneous tracking
TTFF ^a		Hot start: ≤1 s Warm start: ≤20 s Cold start: ≤28 s
Accuracy ^a		Horizontal: < 2 m (50%); < 4 m (95%) Altitude: < 2 m (50%); < 4 m (95%) Velocity: < 0.2 m/s
Sensitivity ^b	Shared GNSS path (Antenna: ANTO; GNSS L1+L5) Dedicated GNSS path (Antenna: GNSS; GNSS L1) <i>Note: The dedicated GNSS path has similar sensitivity values to the shared GNSS path.</i>	Tracking ^c : <ul style="list-style-type: none"> • GPS: -160 dBm • GLONASS: -158 dBm Reacquisition ^d : <ul style="list-style-type: none"> • GPS: -157 dBm • GLONASS: -156 dBm Cold start (autonomous) acquisition ^d : <ul style="list-style-type: none"> • GPS: -148 dBm • GLONASS: -140 dBm Hot start acquisition ^d : <ul style="list-style-type: none"> • GPS: -155 dBm • GLONASS: -147 dBm
Operational Limits		Altitude <6000 m or velocity <100 m/s (Either limit may be exceeded, but not both.)

- a. TTFF (without AGNSS) and accuracy are measured under open sky conditions with signal strength of -135 dBm.
- b. Performance is tested in conducted mode with GNSS signal simulator is tested under room temperature and without external GNSS LNAs as the module includes internal LNAs for both L1 and L5.
- c. Tracking sensitivity is the lowest GNSS signal level in which the device can still detect in-view satellites and get fixed at least 50% of the time when in sequential tracking mode.
- d. Acquisition sensitivity is the lowest GNSS signal strength for which the device can still detect in-view satellites and get fixed at least 50% of the time.

4: Power

4.1 Power Consumption

Note: Power consumption data is measured with typical EM929X use cases.

The module does not have its own power source and depends on the host device for power. For a description of input voltage requirements, see [Power Supply on page 26](#).

Important: Sierra Wireless strongly recommends that the host platform's power supply be able to meet the stated maximum power consumption plus a 50% margin.

Table 4-1: EM929x — USB^a Averaged Standby DC Power Consumption

Signal	Description	Bands ^b	Current ^c		Notes / configuration
			Typ	Unit	
VCC	Standby Mode (Host interface in low power state)				
	5G	NR bands	6.2	mA	DRX cycle = 1.28 s
	LTE	LTE bands	5.7	mA	DRX cycle = 1.28 s
	HSPA / WCDMA	UMTS bands	5.4	mA	DRX cycle = 2.56 s
	Standby Mode (Host interface in operational state)				
	5G	NR bands	62.0	mA	DRX cycle = 1.28 s
	LTE	LTE bands	61.9	mA	DRX cycle = 1.28 s
	HSPA / WCDMA	UMTS bands	60.5	mA	DRX cycle = 2.56 s
	Low Power Mode (LPM)/Offline Mode (Host interface in low power state)				
	RF disabled, but module is operational			4.7	mA
Low Power Mode (LPM)/Offline Mode (Host interface in operational state)					
RF disabled, but module is operational			60.4	mA	

a. USB 3.2 Gen2x1 (Superspeed+) interface

b. For supported bands, see [Table 3-5, Supported Frequency Bands, by RAT \(5G NR/LTE/3G\)](#), on page 46.

c. Measured at 25°C/nominal 3.3 V voltage.

Table 4-2: EM929x — PCIe^a Averaged Standby DC Power Consumption

Signal	Description	Bands ^b	Current ^c		Notes / configuration	
			Typ	Unit		
VCC	Standby Mode (Host interface in low power state)					
	5G	NR bands	4.2	mA	DRX cycle = 1.28 s	
	LTE	LTE bands	3.5	mA	DRX cycle = 1.28 s	
	HSPA / WCDMA	UMTS bands	3.0	mA	DRX cycle = 2.56 s	
	Standby Mode (Host interface in operational state)					
	5G	NR bands	59.9	mA	DRX cycle = 1.28 s	
	LTE	LTE bands	59.8	mA	DRX cycle = 1.28 s	
	HSPA / WCDMA	UMTS bands	58.5	mA	DRX cycle = 2.56 s	
	Low Power Mode (LPM)/Offline Mode (Host interface in low power state)					
	RF disabled, but module is operational			2.5	mA	
	Low Power Mode (LPM)/Offline Mode (Host interface in operational state)					
	RF disabled, but module is operational			58.3	mA	

- a. PCI Gen 3 single lane interface.
- b. For supported bands, see [Table 3-5, Supported Frequency Bands, by RAT \(5G NR/LTE/3G\)](#), on page 46.
- c. Measured at 25°C/nominal 3.3 V voltage.

Table 4-3: EM9291 / EM9291P — Averaged Call Mode DC Power Consumption

Mode	Description	Tx power (dBm)	Current (mA) ^{a,b}	Configuration ^c	Bands
5G NR Sub-6 GHz EN-DC	LTE 4CC + 5G NR Sub-6 GHz DL/UL 1CC	0 (LTE); 0 (NR)	860	DL only 2970 Mbps; Sub-6 GHz 100 MHz/CC, DL/UL duty cycle ~87%, Rx: 1CC, 4x4 MIMO, -50 dBm, 256QAM, RB=273, MCS=27; Tx: SISO, 256QAM; LTE: DL 4CC, 12 Layers, 20 MHz/CC, 256QAM, RB=100, MCS=27; Tx: 256QAM	3C+7C+n78
		18 (LTE); 18 (NR)	1210		
	LTE 4CC + 5G NR Sub-6 GHz DL/UL 1CC, Max RF power	23 (LTE); 22 (NR)	1490		
(EM9291P only) 5G NR Sub-6 GHz UL MIMO PC1.5	5G NR Sub-6 GHz DL/UL 1CC	29 (26+26)	850	40 MHz BW, UL 2x2 MIMO; Rx: 4x4 MIMO, -50 dBm; Tx: MIMO, SMSL (spatial multiplexing single layer), FPTM 1 (Full power Tx mode 1), DFT-s-ofdm, QPSK UL duty cycle 20%	n79

Table 4-3: EM9291 / EM9291P — Averaged Call Mode DC Power Consumption (Continued)

Mode	Description	Tx power (dBm)	Current (mA) ^{a,b}	Configuration ^c	Bands
LTE	LTE FDD DL 5CC, UL 2CC	0 (PCC); 0 (SCC)	760	DL only 1570 Mbps; FDD, 20 MHz/CC, DL: 5CC, 16 Layers, 256QAM, RB=100, MCS=27; UL: 2CC, 256QAM	1A+3C+7C
		18 (PCC); 18 (SCC)	1040		
	LTE FDD DL 5CC, UL 2CC Max RF power	19.5 (PCC); 19.5 (SCC)	1140	DL only 1570 Mbps; FDD, 20 MHz/CC, DL: 5CC, 16 Layers, 256QAM, RB=100, MCS=27; UL: 2CC, QPSK	

- a. Measured at 25°C/nominal 3.3 V voltage
- b. Measurement does not include UL data, which may add a small current increase of 100–200 mA.
- c. The measurement is using the EM929X development kit with a heatsink.

Table 4-4: EM9293 / EM9293P — Averaged Call Mode DC Power Consumption

Mode	Description	Tx power (dBm)	Current ^{a,b} (mA)	Configuration ^c	Bands
5G NR Sub-6 GHz EN-DC	LTE 5CC + 5G NR Sub-6 GHz DL/UL 1CC	0 (LTE); 0 (NR)	1420	DL only 3780 Mbps; 5G NR Sub-6 GHz 100 MHz/CC, DL/UL duty cycle ~87%, Rx: 1CC, 4x4 MIMO, -50 dBm, 256QAM, RB=273, MCS=27; Tx: SISO, 256QAM; LTE: DL 5CC, 4x4 MIMO, 20 MHz/CC, 256QAM, RB=100, MCS=27; Tx: 256QAM	1A+3C+7C+n78
		18 (LTE); 18 (NR)	1710		
	LTE 5CC + 5G NR Sub-6 GHz DL/UL 1CC, Max RF power	23 (LTE); 22 (NR)	1990	DL only 3780 Mbps; 5G NR Sub-6 GHz 100 MHz/CC, DL/UL duty cycle ~87%, Rx: 1CC, 4x4 MIMO, -50 dBm, 256QAM, RB=273, MCS=27; Tx: SISO, QPSK; LTE: DL 5CC, 4x4 MIMO, 20 MHz/CC, 256QAM, RB=100, MCS=27; Tx: SISO, QPSK	
(EM9293P only) 5G NR Sub-6 GHz UL MIMO PC1.5	5G NR Sub-6 GHz DL/UL 1CC	29 (26+26)	850	40 MHz BW, UL 2x2 MIMO; Rx: 4x4 MIMO, -50 dBm; Tx: MIMO, SMSL (spatial multiplexing single layer), FPTM 1 (Full power Tx mode 1), DFT-s-ofdm, QPSK UL duty cycle 20%	n79
LTE	LTE FDD DL 5CC 4x4 UL 2CC	0 (PCC); 0 (SCC)	890	DL only 1960 Mbps; FDD, 20 MHz/CC, DL: 5CC, 20 layers, 4x4 MIMO, 256QAM, RB=100, MCS=27; UL: 2CC, 256QAM	1A+3C+7C
		18 (PCC); 18 (SCC)	1180		
	LTE FDD DL 5CC 4x4 / UL 2CC Max RF power	19.5 (PCC); 19.5 (SCC)	1260	DL only 1960 Mbps; FDD, 20 MHz/CC, DL: 5CC, 20 layers, 4x4 MIMO, 256QAM, RB=100, MCS=27; UL: 2CC, QPSK	

- a. Measured at 25°C/nominal 3.3 V voltage
- b. Measurement does not include UL data, which may add a small current increase of 100–200 mA.
- c. The measurement is using the EM929X development kit with a heatsink.

Table 4-5: Miscellaneous DC Power Consumption

Signal	Description	Current / Voltage				Description	
		Min	Typ	Max	Unit		
VCC	Inrush current	—	—	3.0	A	Assume power supply turn-on time > 100 μ s Dependent on host power supply rise time.	
	Peak current	Power Class 2	—	—	3.0 ^a	A	<ul style="list-style-type: none"> Across all bands, all temperature ranges 3.3V supply
		Power Class 1.5	—	—	5.0 ^a	A	
	Continuous current	—	—	2.8	A		
Leakage current	—	150	200	μ A	<ul style="list-style-type: none"> Module powered off <ul style="list-style-type: none"> Full_Card_Power_Off_N is Low VCC is supplied 		
GNSS Signal collector	Active bias on GNSS port	—	—	100	mA		
		3.0	3.15	3.25	V	Voltage applied to the GNSS antenna to power electronics inside the antenna (GNSS RF receptacle in Figure 3-1 on page 40). <i>Note: The EM929X module's VCC input must be 3.3 V (minimum) to guarantee the voltage level at the GNSS connector.</i>	

a. Peak current without recommended supercapacitor. Peak current can be mitigated by adding a 1.5 mF supercapacitor as described in [4.1.1 Peak Current Mitigation](#).

4.1.1 Peak Current Mitigation

Due to the high peak current for EM929X modules, especially for PC1.5 operation of EM9291P/EM9293P, a 1.5 mF supercapacitor connected to VCC is strongly recommended to mitigate the module's peak current.

As shown in [Figure 4-1](#) below, the module's peak current can be reduced by approximately 1 A when the host product is designed with a supercapacitor.

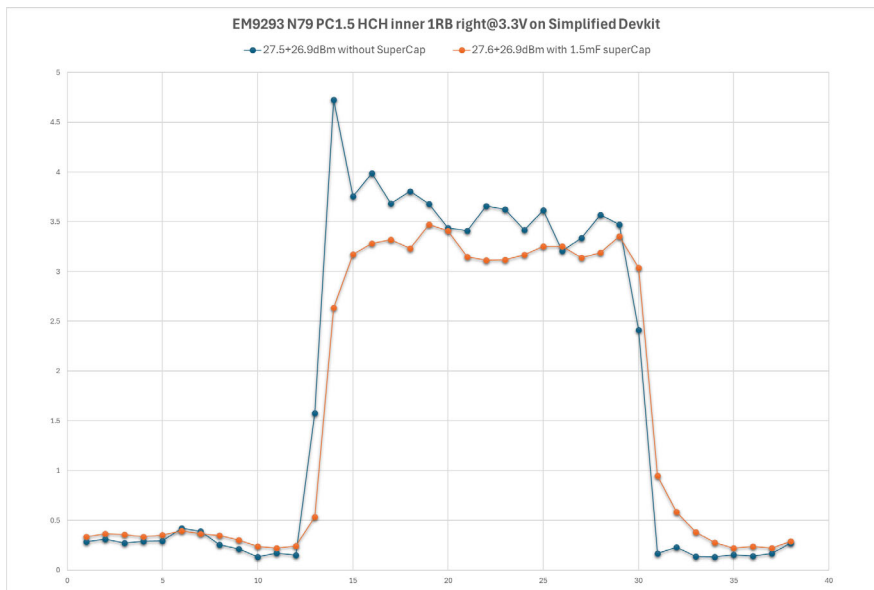

Figure 4-1: Effect of Supercapacitor on PC1.5 Peak Current

4.2 Module Power States

The module has five power states, as described in [Table 4-6](#).

Table 4-6: Module Power States

State	Details	Host is powered	Host interface active	RF enabled
Normal (Default state)	<ul style="list-style-type: none"> ▪ Module is active ▪ Default state. Occurs when VCC is first applied, Full_Card_Power_Off_N is deasserted (pulled high), and W_DISABLE_N is deasserted ▪ Module is capable of placing/receiving calls, or establishing data connections on the wireless network ▪ Current consumption is affected by several factors, including: <ul style="list-style-type: none"> • Radio band being used • Transmit power • Receive gain settings • Data rate 	Y	Y	Y
Low power (Airplane mode)	<ul style="list-style-type: none"> ▪ Module is active ▪ Module enters this state: <ul style="list-style-type: none"> • Under host interface control: <ul style="list-style-type: none"> • Host issues AT+CFUN=0 ([16] AT Command Set for User Equipment (UE) (Release 6) (Doc# 3GPP TS 27.007)), or • Host asserts W_DISABLE_N, after AT!PCOFFEN=0 has been issued. • Automatically, when critical temperature or voltage threshold limits are reached. 	Y	Y	N
Sleep	<ul style="list-style-type: none"> ▪ Normal state of module between calls or data connections ▪ Module cycles between wake (polling the network) and sleep, at network provider-determined interval. 	Y	N	N
Off	<ul style="list-style-type: none"> ▪ Host keeps module powered off by asserting Full_Card_Power_Off_N (signal pulled low or left floating) ▪ Module draws minimal current ▪ See Full_Card_Power_Off_N and RESET_N on page 35 for more information. 	Y	N	N
Disconnected	<ul style="list-style-type: none"> ▪ Host power source is disconnected from the module and all voltages associated with the module are at 0 V. 	N	N	N

4.2.1 Power State Transitions

The module uses state machines to monitor supply voltage and operating temperature. (See [Table 4-7](#) for threshold details and [Figure 4-2](#) for state machine behavior.)

Power state transitions may occur:

- Automatically, when critical supply voltage or module temperature threshold levels are encountered.
- Under host control, using available AT commands in response to user choices (for example, opting to switch to airplane mode) or operating conditions.

Table 4-7: Power State Thresholds

Voltage		Temperature ^a		Notes
Threshold	V	Threshold	°C	
VOLT_HI_CRIT	4.6	TEMP_HI_CRIT	118	Transition from Normal mode (online) to Low Power mode (offline) when the voltage or temperature rises above the corresponding threshold value.
VOLT_HI_WARN	4.4	TEMP_HI_WARN	100	When the voltage or temperature is between the corresponding high warning and high critical thresholds, set a warning and remain in the current mode (Normal or Low Power). Note — If the device is in Normal mode (online) and the temperature warning is set, the module performance may be reduced (Class B temperature range).
VOLT_NORM	3.3	TEMP_NORM	70	Operate in Normal mode (online) while the voltage and temperature are both between their corresponding high and low warning threshold values.
VOLT_LO_WARN	3.135	TEMP_LO_WARN	-30	When the voltage or temperature is between the corresponding low warning and low critical thresholds, set a warning and remain in the current mode (Normal or Low Power). Note — If the device is in Normal mode (online) and the temperature warning is set, the module performance may be reduced (Class B temperature range).
VOLT_LO_CRIT	2.9	TEMP_LO_CRIT	-45	Transition from Normal mode (online) to Low Power mode (offline) when the voltage or temperature drops below the corresponding threshold value.
MANUAL TRANSITION TO OFF MODE		Recommendation — A host-initiated (manual) power off is recommended when either the supply voltage or the module operating temperature is critically low or high. (Note — The host should provide a stable and valid voltage level to the module to ensure the voltage does not enter high or low critical ranges.)		

a. Highest junction temperature among onboard chipsets (PAs, PMIC, SDX65/SDX62)

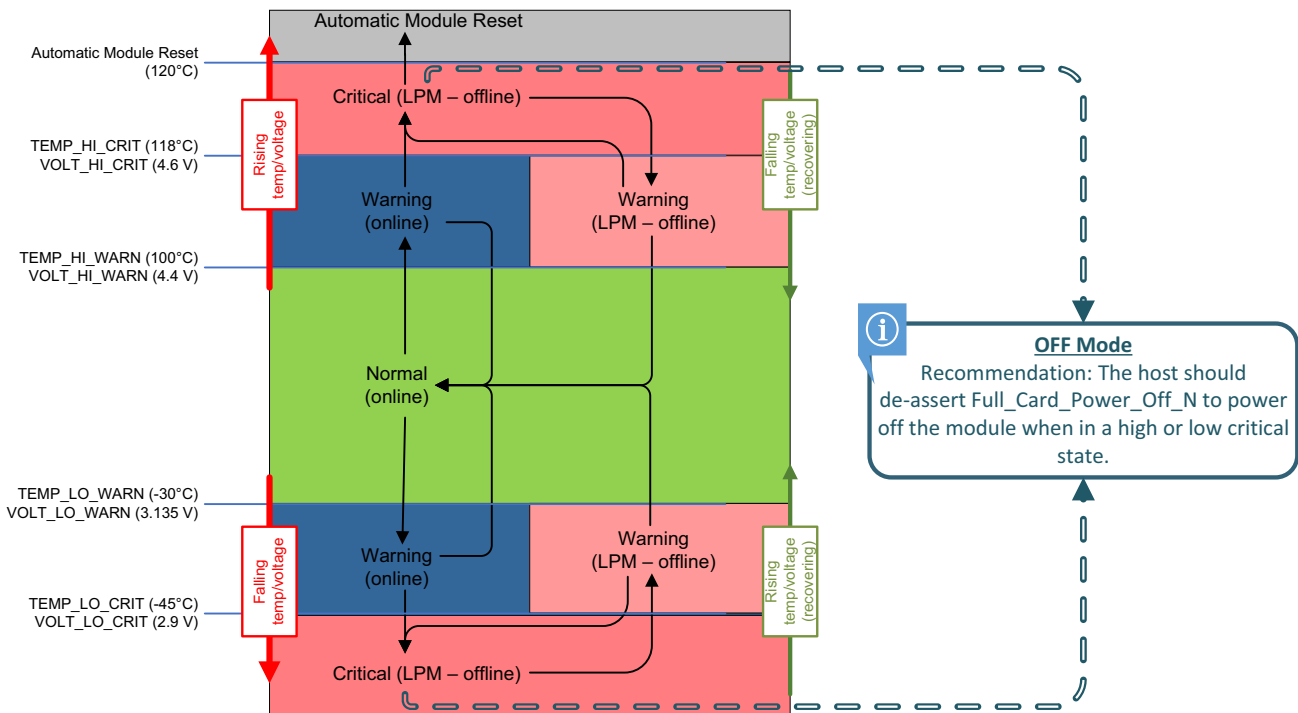

Figure 4-2: Voltage/Temperature Monitoring State Machines

4.3 Power Interface

4.3.1 Power Ramp-up

On initial power up, inrush current depends on the power supply rise time — turn on time > 100 μ s is required for < 3 A inrush current.

The supply voltage must remain within specified tolerances while this is occurring.

If the host device cannot meet these specifications, the module may not boot properly.

4.3.2 Timing

4.3.2.1 Power On/Off Timing for PCIe Interface

[Figure 4-3](#) describes the timing of PCIe interface detection in the power-on/off sequence.

(Note: If the PCIe interface has stalled, it must be re-initialized. If the host platform is designed to restart PCIe link training, the PCIe timing figure ([Figure 4-3](#)) can be used for re-initialization, or the [Required Shutdown Sequence on page 63](#) method can be used to power off the module and then reboot the module. However, if the host platform cannot restart link training or is not responding to Full_Card_Power_Off_N, use the shutdown sequence *and* reset the host platform.)

Note: Before reaching the "Active" state, signals on the host interface are undefined and signal transitions may occur. This undefined state also applies when the module is in reset mode, during a firmware update, or during the Power-off sequence. The host must consider these undefined signal activities when designing the module interface.

Important: The host must not drive any signals to the module until > 100 ms from the start of the power-on sequence.

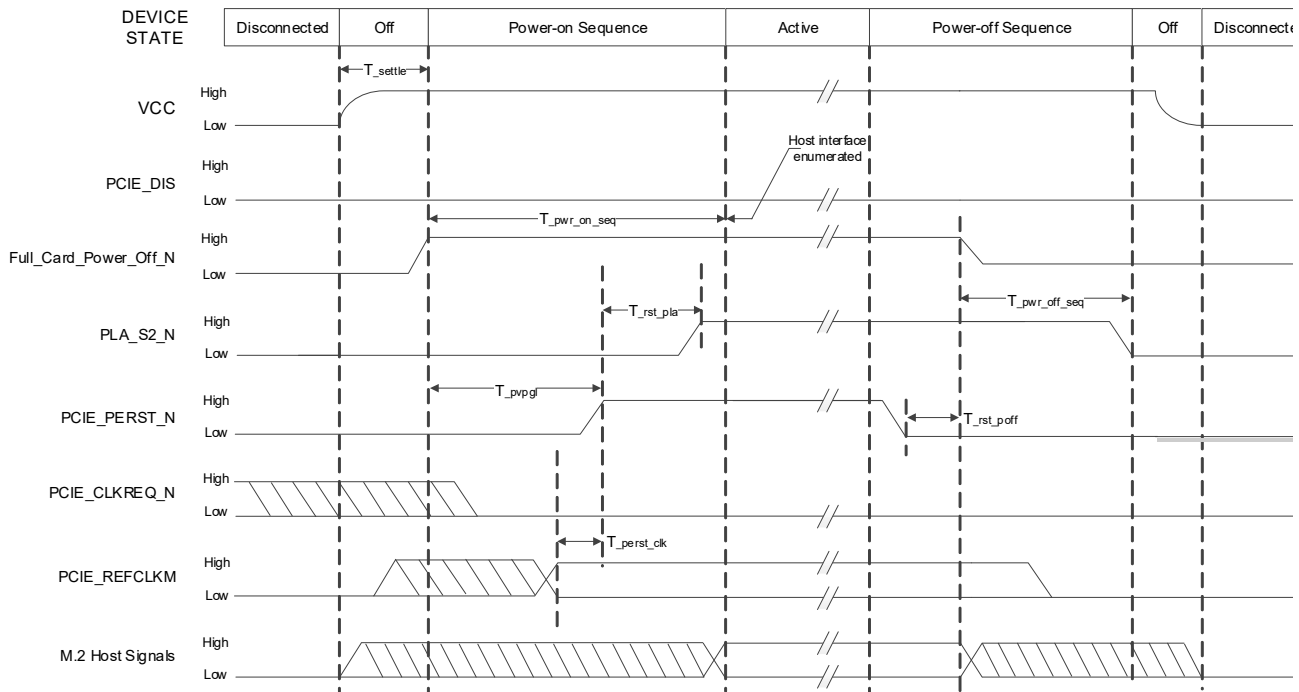

Figure 4-3: Power On/Off Timing—PCIe Interface

Table 4-8: PCIe Timing

Symbol	Parameter	Min	Typ	Max	Unit
T_settle	Power on to Power Valid	—	—	—	ms
T_pvppl ^a	Power Valid to PCIE_PERST_N input high	150	—	—	ms
T_rst_pla	PCIE_PERST_N high to PLA_S2_N high	—	760	950	ms
T_rst_poff	PCIE_PERST_N low to Full_Card_Power_Off_N low	0	See ^b	—	s
T_pwr_on_seq ^c	Power on sequence time	—	43	53	s
T_pwr_off_seq ^d	Power off sequence time	—	8	12	s
T_perst_clk	PCIE_REFCLKM stable before PCIE_PERST_N high	100	—	—	μs

- T_pvppl is dependent on the host PCIe controller implementation.
- PCIE_PERST_N can be asserted (signal low) any time up to the moment Full_Card_Power_Off_N is asserted.
- T_pwr_on_seq is a function of T_pvppl.
- If Full_Card_Power_Off_N is asserted while the module is booting up, the module will complete the boot process (T_pwr_on_seq) and then execute the power off sequence.

Note: Power Valid when all the voltage supply rails have reached their respective V_{min}

T_settle is dependent on the host power design—e.g., a typical Adapter with a load capacitance of 330 μF and a 200 mA Soft-Start current limited ramp on the 3.3 V power rail, should settle within 5 ms.)

4.3.2.2 Power On / Off Timing for USB Interface

Figure 4-4 describes the timing of USB interface detection in the power on/off sequence.

Note: Before reaching the "Active" state, signals on the host interface are undefined and signal transitions may occur. This undefined state also applies when the module is in reset mode, during a firmware update, or during the Power-off sequence. The host must consider these undefined signal activities when designing the module interface.

Important: *The host must not drive any signals to the module until > 100 ms from the start of the power-on sequence.*

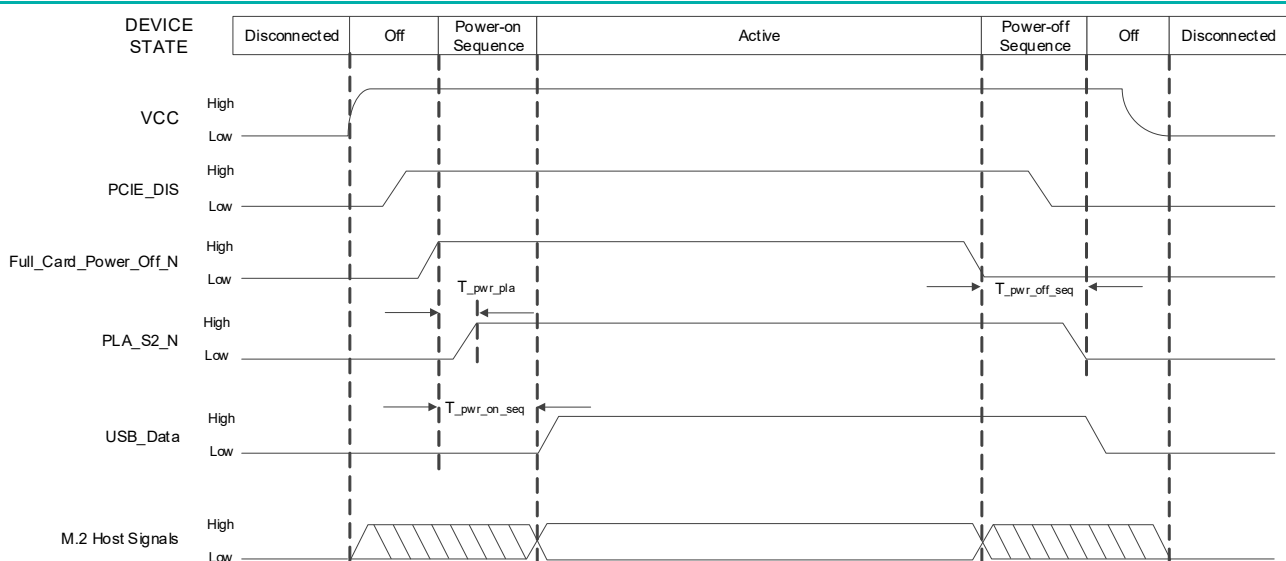

Figure 4-4: Signal Timing (Full_Card_Power_Off_N, and USB Enumeration)

Table 4-9: USB Power-On / Off Timing Parameters

Symbol	Parameter	Min	Typ	Max	Unit
$T_{pwr_on_seq}$	Power on sequence time	—	52	62	s
T_{pwr_pla}	Power on to PLA_S2_N high	—	0.91	1.1	s
$T_{pwr_off_seq}^a$	Power off sequence time	—	6	10	s

a. If Full_Card_Power_Off_N is asserted while the module is booting up, the module will complete the boot process ($T_{pwr_on_seq}$) and then execute the power off sequence.

4.3.2.3 Reset Timing

To reset the module, see Table 2-9 on page 35 for RESET_N signal usage instructions.

4.3.2.4 Required Shutdown Sequence

Important: *To avoid causing issues with the file system, follow this shutdown sequence. Note that this sequence works only on a module that has completely booted up.*

To safely power off the module:

1. Drive Full_Card_Power_Off_N low to trigger the firmware to safely power off.
2. Wait until PLA_S2_N is asserted to low.

Note: The power off process finishes within $T_{pwr_off_seq}$ seconds (Table 4-9).

3. Remove power.

4.3.3 Power Supply Noise

Noise in the power supply can lead to noise in the RF signal.

The power supply ripple limit for the module is no more than 100 mVp-p, 1–100 kHz. This limit includes voltage ripple due to transmitter burst activity.

Additional decoupling capacitors can be added to the main VCC line to filter noise into the device.

4.3.4 SED (Smart Error Detection)

The module uses a form of SED to track premature modem resets.

- Module tracks consecutive resets occurring soon after power-on.
- After a sixth consecutive reset, the module waits in boot-and-hold mode for a firmware download to resolve the power-cycle problem.

5: Software

Mobile Broadband Packages are available for EM929X modules on the specific device pages at source.sierrawireless.com or on private Sharepoint portals.

EM929X modules support USB and PCIe as physical host interfaces.

These packages are software suites that include:

- Device drivers
- SDK
- Tools and documentation (Firmware Logging and troubleshooting utilities, Developer's guide)

For PCIe development resources (available subject to license agreement), please contact your Sierra Wireless representative.

6: Mechanical and Environmental Specifications

EM929X modules comply with the mechanical and environmental specifications in [Table 6-1](#). Final product conformance to these specifications depends on the [OEM](#) device implementation.

Table 6-1: Mechanical and Environmental Specifications

	Mode	Details
Ambient temperature	Operational Class A	-30°C to +70°C — 3GPP compliant, with host application-appropriate heatsinking, when using a suitable external SIM (Note: The onboard eSIM is operational between -25°C to +85°C.)
	Operational Class B	-40°C to +85°C, with host application-appropriate heatsinking, when using a suitable external SIM — non-3GPP compliant (reduced operating parameters required) (Note: The onboard eSIM is operational between -25°C to +85°C.)
	Storage	-40°C to +85°C (at up to 85% RH, non-condensing)
Humidity Test	15 minutes Idle / 15 minutes Off	Test temperature: 85°C Relative humidity: 85% Stress duration: 10 days
Thermal Shock Test	Non-operational	Test temperature: -40°C to +85°C Temperature transition time: < 30 seconds Dwell time: 10 minutes Stress duration: 300 cycles
High Temperature Operating Life Test	45 minutes Max TX / 15 minutes Idle	Temperature: 85°C Stress duration: 20 days (480 cycles)
Low Temperature Cold Start Test	30 minutes Off / 5 minutes Idle	Test temperature: -40°C Stress duration: 5 days
Mechanical Shock	Non-operational	Waveform: Half sine Peak acceleration: 30 g Shock duration: 6 ms Number of shocks: 3 Shock direction: ±X, ±Y, ±Z
Operational Durability	Non-operational	Number of mating and un-mating cycles per connector: <ul style="list-style-type: none"> • M.2 edge connector: 20 (minimum) • Antenna receptacles: 10 (minimum)
Drop	Non-operational	Number of drops: 1 drop per direction (±X, ±Y, ±Z), 6 directions — total 6 drops per module Unprotected drops onto a surface that meets the test standard requirement Drop height: 1 m

Table 6-1: Mechanical and Environmental Specifications (Continued)

	Mode	Details									
Electrostatic Discharge (See Electrostatic Discharge (ESD) on page 72.)	Operational	The LTE/Sub-6 GHz antenna ports and (for EM9293/EM9293P only) the GNSS antenna port comply with the IEC 61000-4-2:2008 standard: <ul style="list-style-type: none"> ▪ Electrostatic discharge immunity: Test Level 3 ▪ Contact discharge: ±6 kV 									
	Non-operational	The host connector interface (M.2) complies with the following standard only: <ul style="list-style-type: none"> ▪ Minimum ±500 V Human Body Model (JS-001-2017) 									
Form factor		M.2 Form Factor (Conforms to width specification)									
Dimensions		Length: 52±0.15 mm (max, exclude depanel burr) Width: 30±0.15 mm (max, exclude depanel burr) Thickness: 2.38 mm (max): <ul style="list-style-type: none"> ▪ Above PCB — 1.50 mm (max) ▪ PCB — 0.88 mm (max) Weight: 9 g (max)									
MTBF		Temperature: 25°C									
		<table border="1"> <thead> <tr> <th></th> <th>Fixed location</th> <th>Mobile</th> </tr> </thead> <tbody> <tr> <td>EM9291/EM9291P</td> <td>146.3 years</td> <td>73.2 years</td> </tr> <tr> <td>EM9293/EM9293P</td> <td>125.0 years</td> <td>62.5 years</td> </tr> </tbody> </table>		Fixed location	Mobile	EM9291/EM9291P	146.3 years	73.2 years	EM9293/EM9293P	125.0 years	62.5 years
			Fixed location	Mobile							
EM9291/EM9291P	146.3 years	73.2 years									
EM9293/EM9293P	125.0 years	62.5 years									

6.1 Device Views

Device view images in this section are subject to change with respect to shield design and to test points on the bottom side of the module.

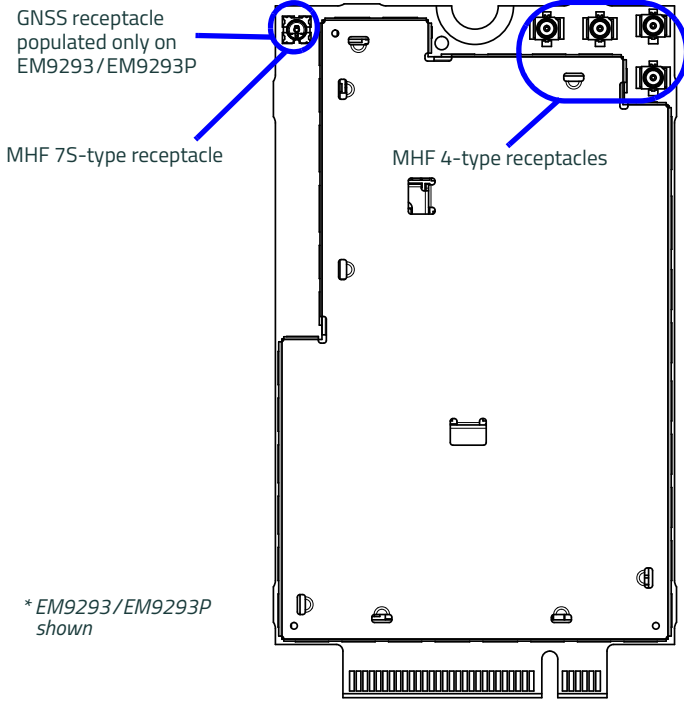

Top View — EM929X

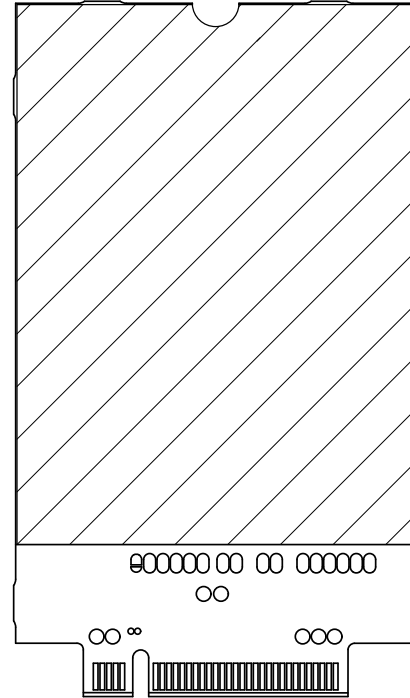

Bottom View — EM929X

No dedicated GNSS receptacle on EM9291/EM9291P

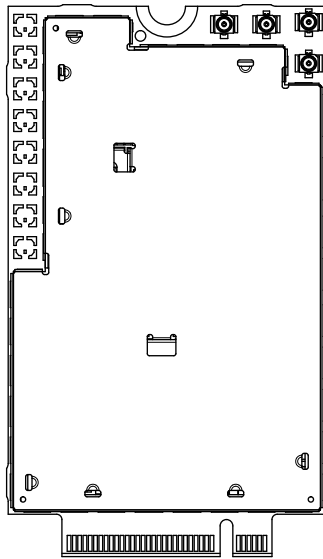

Top View — EM9291/EM9291P

GNSS receptacle populated only on EM9293/EM9293P

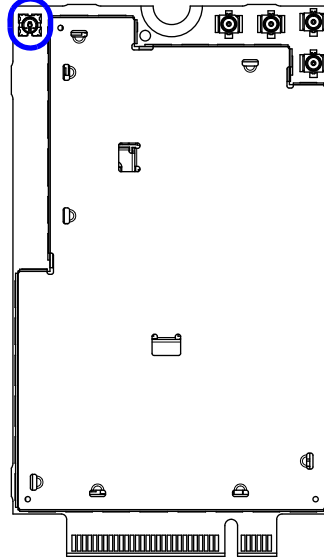

Bottom View — EM9291/EM9291P

Figure 6-1: EM929X Top View and Bottom View

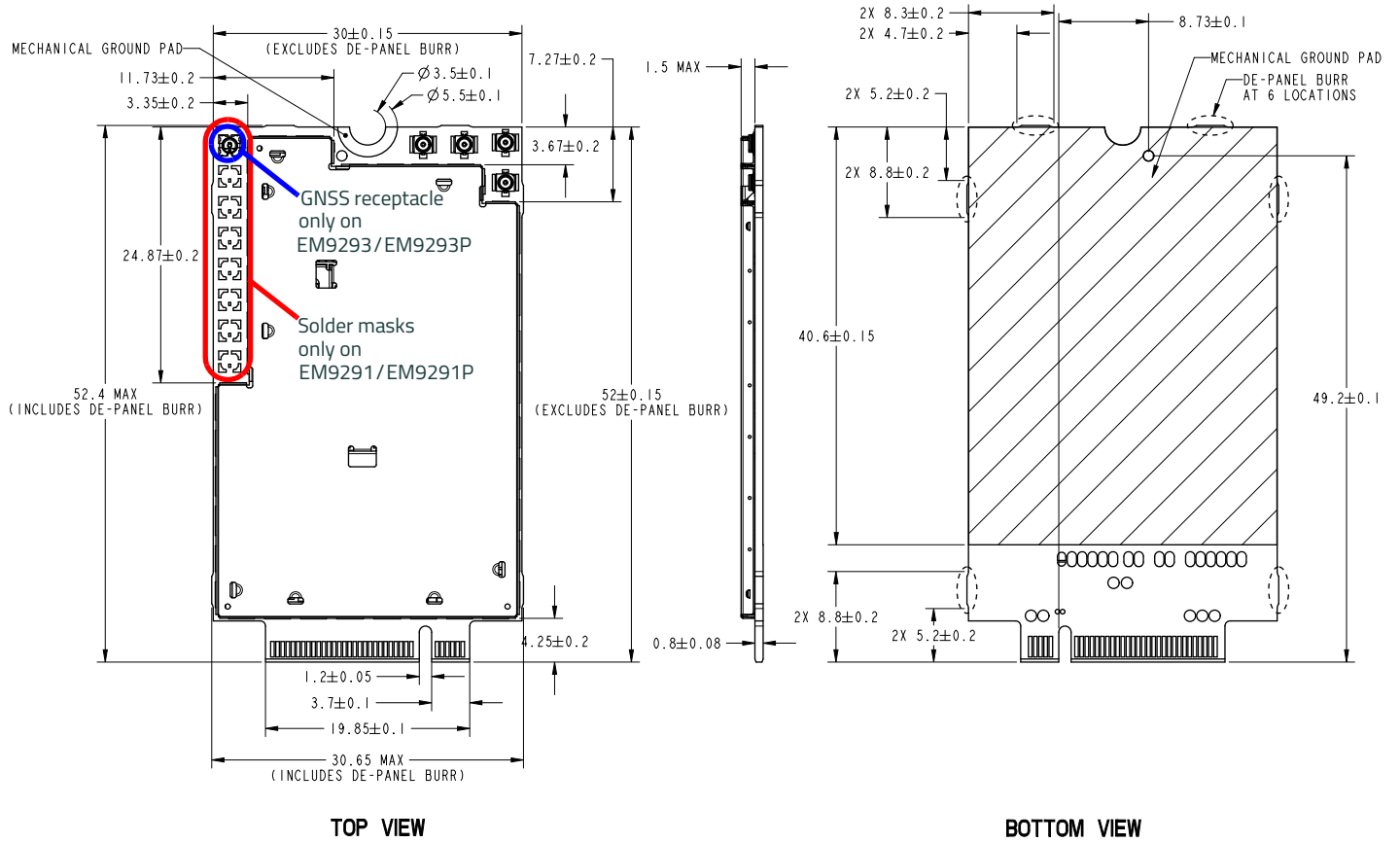

(Source: EM929x mechanical reference 5306633 r4)

Figure 6-2: EM929X Dimensioned View of Mechanical Outline

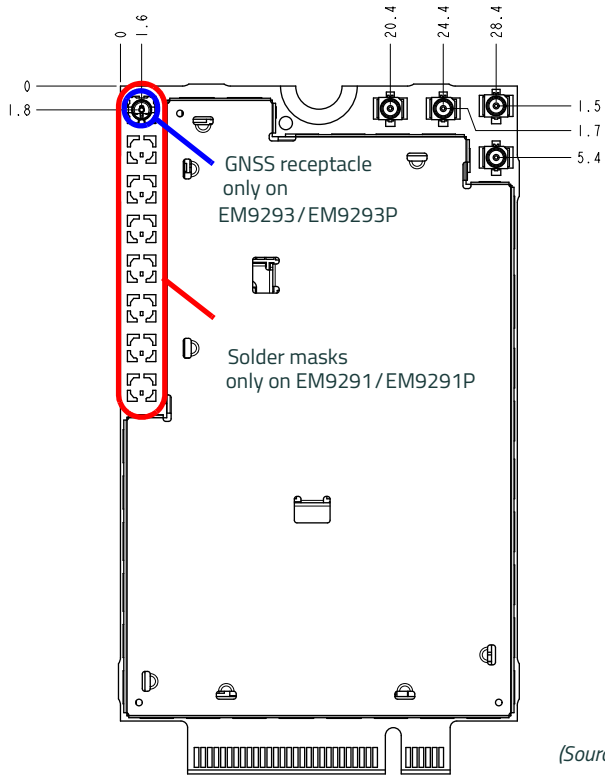
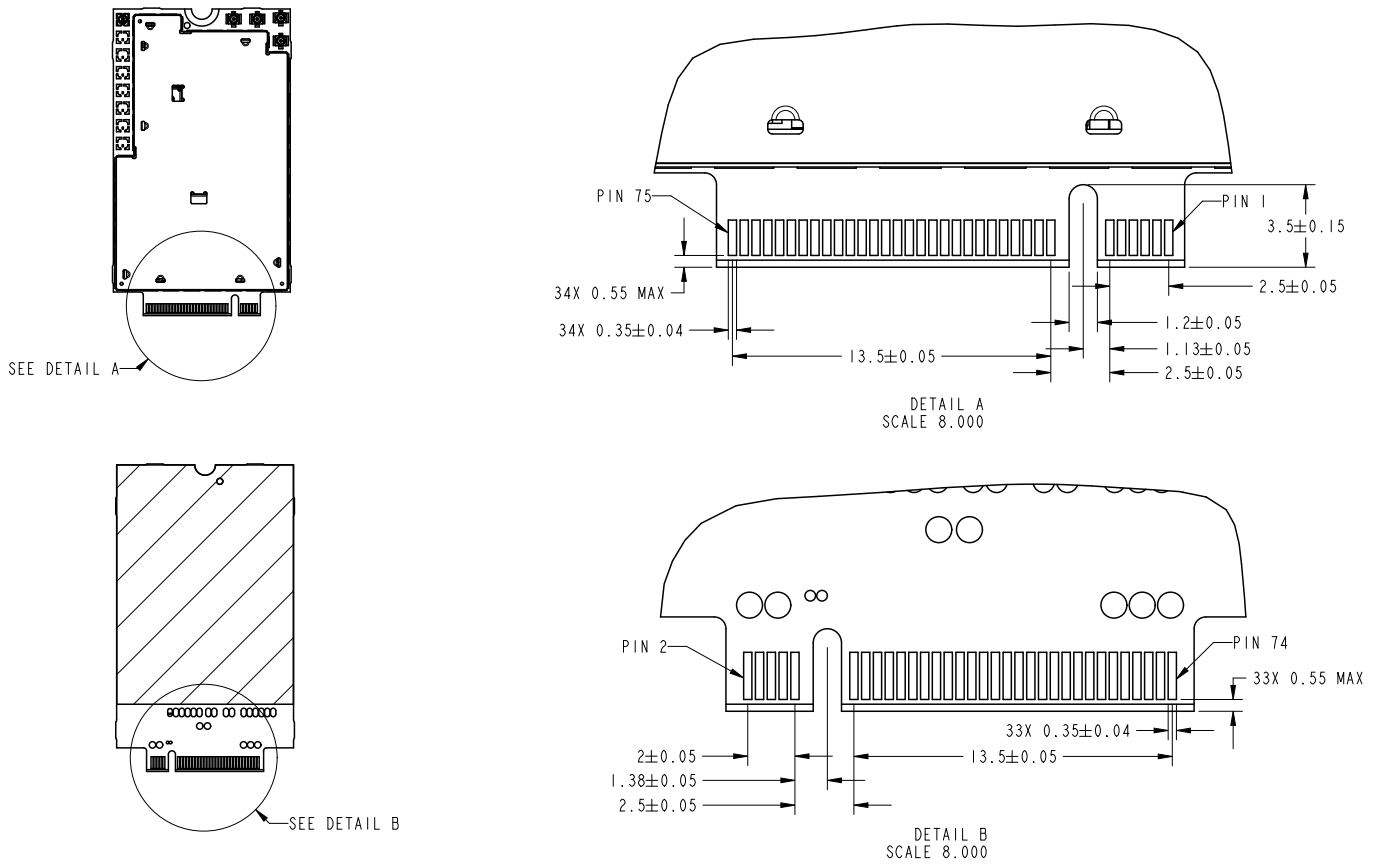

Figure 6-3: EM929X Dimensioned View of Receptacle Locations



(Source: EM929x mechanical reference 5306633 r4)

Figure 6-4: EM929X Dimensioned View of Pin-out

6.2 Product Marking (Labeling)

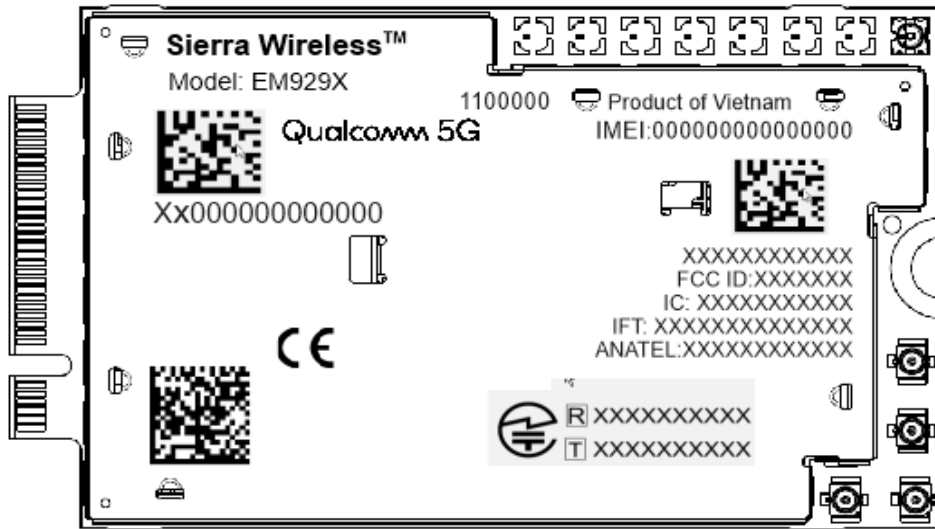

(Source: EM929x Marking Spec 5307609 r4)

Figure 6-5: EM929X Unit Product Marking Example—Laser-etched, Typical Representation

The EM929X module’s product marking is laser-etched and may contain:

- Sierra Wireless logo and product name
- **IMEI** number in Data Matrix barcode format and text format
- **SKU** number (when required)
- Factory Serial Number (**FSN**) in alphanumeric format
- Manufacturing date code (incorporated into FSN)
- Licensed vendor logo
- Certification marks / details
- Customer Part Number (CPN) in Data Matrix barcode format and text format
- Barcodes
- Country of origin (i.e., Manufacture location)

*Note: EM929X modules support **OEM** partner-specific label requirements.*

6.3 Electrostatic Discharge (ESD)

The OEM is responsible for ensuring that the EM929X module’s host interface pins are not exposed to ESD during handling or normal operation. (See [Table 6-1 on page 66](#) for specifications.)

ESD protection is highly recommended for the SIM connector at the point where the contacts are exposed, and for any other signals from the host interface that would be subjected to ESD by the user of the product. The device includes ESD protection on the Sub-6 GHz antenna ports.

6.4 Thermal Considerations

Embedded modules can generate significant amounts of heat that must be dissipated in the host device for safety and performance reasons.

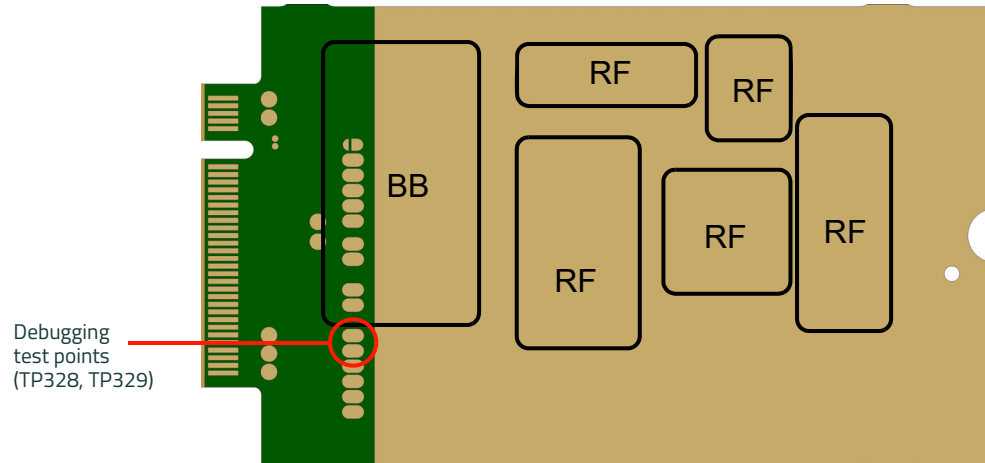

Figure 6-6: Regions requiring thermal dissipation (Bottom view)

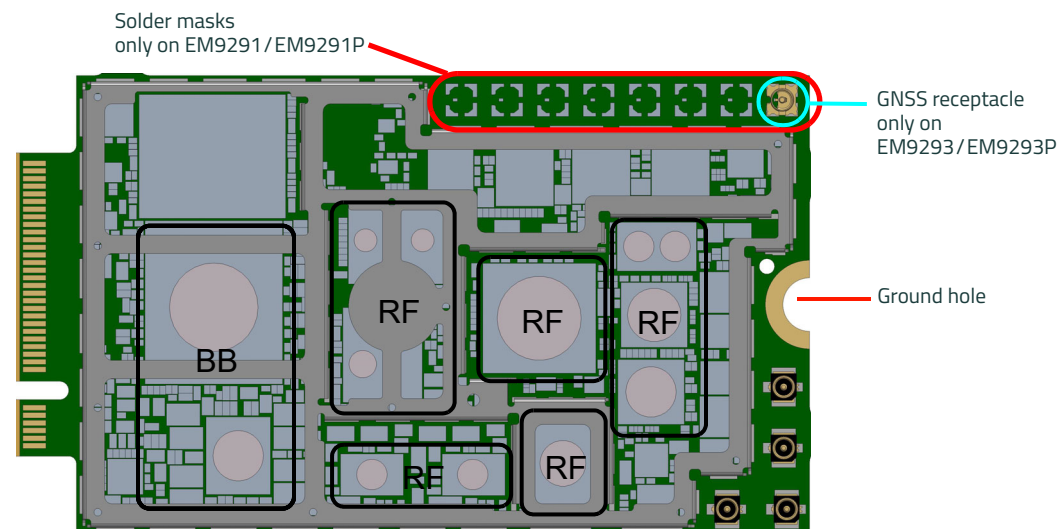

Figure 6-7: Regions requiring thermal dissipation (Top View)

Sierra Wireless recommends that the host device dissipate heat from the bottom surface of the module PCB and, if desired, from the top surface of the module shield. Figure 6-6 and Figure 6-7 display the locations of significant heat sources (BB — baseband components, RF — RF components) that require heat dissipation.

To enhance heat dissipation:

- Sierra Wireless recommends adding a heat sink that mounts the module to the main PCB or metal chassis.
 - Important** — A non-conductive thermal compound or pad must be used between the module and the heat sink.
 - Note — Sierra Wireless recommends that the debugging test points (TP328 and TP329, see Figure 6-6) remain accessible for Sierra Wireless to assist in system debugging. Make sure the test points are not shorted to anything.
- Maximize airflow over/around the module.
- Locate the module away from other hot components.
- Module ground holes must be used to attach (ground) the device to the main PCB ground or a metal chassis.

-
- You may also need active cooling to pull heat away from the module.

Note: Adequate dissipation of heat is necessary to ensure that the module functions properly.

6.5 Module Integration Testing

When testing your integration design:

- Test to your worst case operating environment conditions (temperature and voltage)
- Test using worst case operation
- Monitor temperature at all shield locations. Attach thermocouples to the areas indicated in [Figure 6-7 on page 73](#) (RF, Baseband).

Note: Make sure that your system design provides sufficient cooling for the module.

6.6 Secure Boot/Secure Debug

EM929X modules incorporate the following permanently enabled features to enhance device security:

- **Secure Boot**—Ensures only firmware images signed by Sierra Wireless can be loaded and run on EM929X modules; unauthorized code cannot be loaded to the module.

Specifically, Secure Boot applies to the following firmware components: system boot loader, carrier configuration, and telecom FW.

For details, refer to *[9] EM9 Series Secure Boot (Doc# 2174333 (Forthcoming))*.

- **Secure Debug**—Disables debug features such as RAM dump collection and JTAG access to the module. For details, refer to *[10] EM9 Series Secure Debug (Doc# 2174334 (Forthcoming))*.

7: Regulatory Compliance and Industry Certifications

This chapter describes the current certification status of the EM9291, EM9291P, EM9293 and EM9293P (hereinafter collectively referred to as “EM929x”) modules. Certifications in other countries may be attained upon customer request — contact your Sierra Wireless account representative for details.

Additional testing and certification may be required for the host product with an embedded EM929x module and are the responsibility of the host product manufacturer. Sierra Wireless offers professional services-based assistance to host product manufacturers with the testing and certification process, if required.

7.1 Regulatory Compliance

The EM929x module meets the requirements of the following regulatory bodies and regulations, where applicable:

- Federal Communications Commission (FCC) of the United States
- Innovation, Science and Economic Development Canada (ISED)
- Radio Equipment Directive (RED) and RoHS Directive of the European Union
- Japan Ministry of Internal Affairs and Communications (MIC)
- The National Communications Commission (NCC) of Taiwan, Republic of China

7.1.1 Important Compliance Information for Canada

The EM9291 and EM9293 modules have been granted modular approval for mobile applications under:

- IC: 2417C-EM92

The EM9291P and EM9293P modules, upon commercial release, will have been granted modular approval for mobile applications under:

- IC: 2417C-EM92P

Integrators may use the EM929x module in their host products without additional ISED certification if they meet the following conditions. Otherwise, additional ISED approvals must be obtained.

1. At least 20 cm separation distance between the antenna and the user’s body must be maintained at all times.
2. To comply with ISED regulations limiting both maximum RF output power and human exposure to RF radiation, the maximum antenna gain including cable loss in a mobile-only exposure condition must not exceed the limits stipulated in [Table 7-1](#).
3. The EM929x module may transmit simultaneously with other collocated radio transmitters within a host product, provided the following conditions are met:
 - Each collocated radio transmitter has been certified by ISED for mobile application.
 - At least 20 cm separation distance between the antennas of the collocated transmitters and the user’s body must be maintained at all times.
 - The radiated power of a collocated transmitter must not exceed the EIRP limit stipulated in [Table 7-1](#).

Table 7-1: EM929X ISED Antenna Gain and Collocated Radio Transmitter Specifications

	Operating mode	Tx Freq Range (MHz)		Antenna Gain Limit (dBi)	
				Standalone	Collocated
EM9291 EM9291P EM9293 EM9293P	WCDMA Band 2	1850	1910	7.5	7.0
	WCDMA Band 4	1710	1755	4.5	4.5
	WCDMA Band 5	824	849	5.5	4.5
	LTE B2	1850	1910	7.5	7.0
	LTE B4	1710	1755	4.5	4.5
	LTE B5	824	849	5.5	4.5
	LTE B7	2500	2570	5.5	5.5
	LTE B12	699	716	5.0	4.0
	LTE B13	777	787	5.0	4.5
	LTE B14	788	798	5.0	4.5
	LTE B17	704	716	6.5	5.0
	LTE B25	1850	1915	7.5	7.0
	LTE B26	814	849	5.5	4.5
	LTE B41_PC3	2500	2690	5.5	5.5
	LTE B41_PC2	2500	2690	5.5	5.5
	LTE B42_PC3	3450	3600	4.0	4.0
	LTE B42_PC2	3450	3600	4.0	4.0
	LTE B43_PC3	3600	3800	4.0	4.0
	LTE B43_PC2	3600	3800	4.0	4.0
	LTE B48	3550	3700	4.5	4.5
	LTE B66	1710	1780	4.5	4.5
	LTE B71	663	698	4.5	4.0
	5G NR n2	1850	1910	7.5	7.0
	5G NR n5	824	849	5.5	4.0
	5G NR n7	2500	2570	5.5	5.5
	5G NR n12	699	716	5.0	4.0
	5G NR n13	777	787	5.0	4.5
	5G NR n14	788	798	5.0	4.5
	5G NR n25	1850	1915	7.5	7.0
	5G NR n26	814	849	5.5	4.5

Table 7-1: EM929X ISED Antenna Gain and Collocated Radio Transmitter Specifications (Continued)

	Operating mode	Tx Freq Range (MHz)		Antenna Gain Limit (dBi)	
				Standalone	Collocated
	5G NR n30	2305	2315	-1.5	-1.5
	5G NR n41_PC3	2500	2690	5.5	5.5
	5G NR n41_PC2	2500	2690	5.5	5.5
	(EM9291P/EM9293P only) 5G NR n41_PC1.5	2500	2690	2.5 ^a	2.5 ^a
	5G NR n48	3550	3700	4.5	4.5
	5G NR n66	1710	1780	4.5	4.5
	5G NR n71	663	698	4.5	4.0
	5G NR n77_PC3	3450	3980	2.5	2.5
	5G NR n77_PC2	3450	3980	2.5	2.5
	(EM9291P/EM9293P only) 5G NR n77_PC1.5	3450	3980	-0.5 ^a	-0.5 ^a
	5G NR n78_PC3	3450	3800	2.5	2.5
	5G NR n78_PC2	3450	3800	2.5	2.5
	(EM9291P/EM9293P only) 5G NR n78_PC1.5	3450	3800	-0.5 ^a	-0.5 ^a
Collocated transmitters				Maximum EIRP (dBm)	
	WLAN 2.4 GHz	2400	2500	25.0	
	WLAN 5 GHz	5150	5850	25.0	
	WLAN 6 GHz	5925	7125	25.0	
	Bluetooth	2400	2500	20.0	

a. For EM9291P/EM9293P only, antenna gain limits for n41_PC1.5, n77_PC1.5, and n78_PC1.5 are preliminary, pending certification.

4. A label must be affixed to the outside of the host product into which the EM929x module is incorporated, with a statement similar to the following:
 - EM9291, EM9293: **This device contains IC: 2417C-EM92.**
 - EM9291P, EM9293P: **This device contains IC: 2417C-EM92P.**
5. A user manual with the host product must clearly indicate the operating requirements and conditions that must be observed to ensure compliance with current ISED RF exposure guidelines.

Note: Host product manufacturers are responsible for the overall compliance of the host products including, where applicable, all additional equipment authorization and testing not covered by the modular approval (e.g., ISED’s Interference-Causing Equipment Standards, and RF exposure requirements for host products intended for use within 20 cm of the user’s body.)

7.1.2 Important Compliance Information for the United States

The EM9291 and EM9293 modules have been granted modular approval for mobile applications under:

- FCC ID: N7NEM92

The EM9291P and EM9293P modules, upon commercial release, will have been granted modular approval for mobile applications under:

- FCC ID: N7NEM92P

Integrators may use the EM929x module in their host products without additional FCC certification if they meet the following conditions. Otherwise, additional FCC approvals must be obtained.

1. At least 20 cm separation distance between the antenna and the user's body must be maintained at all times.
2. To comply with FCC regulations limiting both maximum RF output power and human exposure to RF radiation, the maximum antenna gain including cable loss in a mobile-only exposure condition must not exceed the limits stipulated in [Table 7-2](#).
3. The EM929x module may transmit simultaneously with other collocated radio transmitters within a host product, provided the following conditions are met:
 - Each collocated radio transmitter has been certified by FCC for mobile application.
 - At least 20 cm separation distance between the antennas of the collocated transmitters and the user's body must be maintained at all times.
 - The radiated power of a collocated transmitter must not exceed the EIRP limit stipulated in [Table 7-2](#).

Table 7-2: EM929X FCC Antenna Gain and Collocated Radio Transmitter Specifications

	Operating mode	Tx Freq Range (MHz)		Antenna Gain Limit (dBi)	
				Standalone	Collocated
EM9291 EM9291P EM9293 EM9293P	WCDMA Band 2	1850	1910	7.5	7.5
	WCDMA Band 4	1710	1755	4.5	4.5
	WCDMA Band 5	824	849	8.5	8.0
	LTE B2	1850	1910	7.5	7.5
	LTE B4	1710	1755	4.5	4.5
	LTE B5	824	849	8.5	8.0
	LTE B7	2500	2570	5.5	5.5
	LTE B12	699	716	8.0	7.5
	LTE B13	777	787	8.5	8.0
	LTE B14	788	798	8.5	8.0
	LTE B17	704	716	9.5	8.0
	LTE B25	1850	1915	7.5	7.5
	LTE B26	814	849	8.5	8.0
	LTE B41_PC3	2496	2690	5.5	5.5
	LTE B41_PC2	2496	2690	5.5	5.5
	LTE B42_PC3	3450	3550	4.0	4.0
	LTE B42_PC2	3450	3550	4.0	4.0
	LTE B48**	3550	3700	-1.0	-1.0
	LTE B66	1710	1780	4.5	4.5
	LTE B71	663	698	7.5	7.5
	LTE B106	897.5	900.5	10.0	10.0
	5G NR n2	1850	1910	7.5	7.5
	5G NR n5	824	849	8.5	7.5
	5G NR n7	2500	2570	5.5	5.5
	5G NR n12	699	716	8.0	7.5
	5G NR n13	777	787	8.5	8.0
	5G NR n14	788	798	8.5	8.0
	5G NR n25	1850	1915	7.5	7.5
	5G NR n26	814	849	8.5	8.0
	5G NR n30*	2305	2315	-1.5	-1.5

Table 7-2: EM929X FCC Antenna Gain and Collocated Radio Transmitter Specifications (Continued)

	Operating mode	Tx Freq Range (MHz)		Antenna Gain Limit (dBi)	
				Standalone	Collocated
	5G NR n41_PC3	2496	2690	5.5	5.5
	5G NR n41_PC2	2496	2690	5.5	5.5
	(EM9291P/EM9293P only) 5G NR n41_PC1.5	2496	2690	2.5 ^a	2.5 ^a
	5G NR n48**	3550	3700	-2.5	-2.5
	5G NR n66	1710	1780	4.5	4.5
	5G NR n70	1695	1710	4.5	4.5
	5G NR n71	663	698	7.5	7.5
	5G NR n77_PC3	3450	3550	2.5	2.5
		3700	3980		
	5G NR n77_PC2	3450	3550	2.5	2.5
		3700	3980		
	(EM9291P/EM9293P only) 5G NR n77_PC1.5	3450	3550	-0.5 ^a	-0.5 ^a
		3700	3980		
	5G NR n78_PC3	3450	3550	2.5	2.5
		3700	3800		
5G NR n78_PC2	3450	3550	2.5	2.5	
	3700	3800			
(EM9291P/EM9293P only) 5G NR n78_PC1.5	3450	3550	-0.5 ^a	-0.5 ^a	
	3700	3800			
Collocated transmitters				Maximum EIRP (dBm)	
	WLAN 2.4 GHz	2400	2500	25.0	
	WLAN 5 GHz	5150	5850	25.0	
	WLAN 6 GHz	5925	7125	25.0	
	Bluetooth	2400	2500	20.0	

a. For EM9291P/EM9293P only, antenna gain limits for n41_PC1.5, n77_PC1.5, and n78_PC1.5 are preliminary, pending certification.

***Important:** The FCC has a strict EIRP limit in band n30 for mobile and portable stations in order to protect adjacent satellite radio, aeronautical mobile telemetry, and deep space network operations. Mobile and portable stations must not have antenna gain exceeding -1.5 dBi in band n30. Additionally, the FCC prohibits the use of external vehicle-mounted antennas for mobile and portable stations in this band.

Fixed stations may often use antennas with higher gain due to increased EIRP limits. For example in band n30, EM929x modules used as fixed customer premises equipment (CPE) stations in the United States may have an antenna gain up to 7.5 dBi in band n30, subject to other operating conditions stipulated in FCC Part 27.

Mobile carriers often have limits on total radiated power (TRP), which requires an efficient antenna. The host product with an embedded module must output sufficient power to meet the TRP requirement but not too much to exceed FCC's EIRP limit. If you need assistance in meeting this requirement, please contact Sierra Wireless.

****Important:** Airborne operations in LTE Band 48 / 5G NR n48 are prohibited.

4. A label must be affixed to the outside of the host product into which the EM929x module is incorporated, with a statement similar to the following:
 - EM9291, EM9293: **This device contains FCC ID: N7NEM92.**
 - EM9291P, EM9293P: **This device contains FCC ID: N7NEM92P.**
5. A user manual with the host product must clearly indicate the operating requirements and conditions that must be observed to ensure compliance with current FCC RF exposure guidelines.

Note: Host product manufacturers are responsible for the overall compliance of the host products including, where applicable, all additional equipment authorization and testing not covered by the modular approval (e.g., unintentional radiator FCC Part 15 Subpart B requirements, and RF exposure requirements for host products intended for use within 20 cm of the user's body.)

7.2 Industry Certifications

The EM929x module complies with the mandatory requirements described in the following standards. The exact set of requirements supported is network operator-dependent.

Table 7-3: Standards Compliance

RAT	Standards
5G NR Sub-6 GHz	▪ 3GPP Release 16
LTE	▪ 3GPP Release 16
UMTS	▪ 3GPP Release 9

The following industry certifications have been obtained, where applicable:

- GCF
- PTCRB

A: Antenna Specification

This appendix describes recommended electrical performance criteria for Sub-6 GHz and GNSS antennas used with Sierra Wireless embedded modules.

The performance specifications described in this section are valid while antennas are mounted in the host device with antenna feed cables routed in their final application configuration.

*Note: Antennas should be designed **before** the industrial design is finished to make sure that the best antennas can be developed*

A.1 Recommended WWAN Antenna Specifications

Important: Specifications included in [Table A-1](#) are DRAFT, and are intended **only** to identify the general parameters that will be fully defined in subsequent revisions of this document.

Table A-1: Antenna Requirements^a

Parameter	Requirements	Comments
Antenna system	<ul style="list-style-type: none"> ▪ NR/LTE: External multi-band 4x4 DL MIMO antenna system — ANTO, ANT1, ANT2, ANT3 ▪ 3G: External multi-band antenna system with diversity — ANTO, ANT2 	If an antenna includes GNSS, it must also satisfy requirements in Table A-2 on page 84 .
Antenna frequency ranges	<ul style="list-style-type: none"> ▪ ANTO — 617–5925 MHz ▪ ANT1 — 1164–5000 MHz ▪ ANT2 — 617–5000 MHz ▪ ANT3 — 1427–5925 MHz 	
VSWR	<ul style="list-style-type: none"> ▪ ANTO, ANT1, ANT2, ANT3: <ul style="list-style-type: none"> • < 2:1 (recommended) • < 3:1 (worst case) 	On all bands including band edges
Total radiated efficiency	> 50% on all bands	<ul style="list-style-type: none"> ▪ Measured at the RF receptacle. ▪ Includes mismatch losses, losses in the matching circuit, and antenna losses, excluding cable loss. ▪ Sierra Wireless recommends using antenna efficiency as the primary parameter for evaluating the antenna system. ▪ Peak gain is not a good indication of antenna performance when integrated with a host device (the antenna does not provide omni-directional gain patterns). Peak gain can be affected by antenna size, location, design type, etc. — the antenna gain patterns remain fixed unless one or more of these parameters change.
Radiation patterns	Nominally omni-directional radiation pattern in azimuth plane.	

Table A-1: Antenna Requirements^a (Continued)

Parameter	Requirements	Comments
Envelope correlation coefficient	Between receiving antennas: <ul style="list-style-type: none"> < 0.5 on Rx bands below 960 MHz < 0.2 on Rx bands above 1.4 GHz 	To identify the receiving antennas for any band, refer to Table 3-2 on page 41 .
Mean Effective Gain (MEG)	Receiving antennas: <ul style="list-style-type: none"> ≥ -3 dBi 	To identify the receiving antennas for any band, refer to Table 3-2 on page 41 .
Mean Effective Gain Imbalance $\left \frac{MEG_x}{MEG_y} \right $	Between any two antennas: <ul style="list-style-type: none"> < 2 dB for MIMO operation < 6 dB for diversity operation 	
Maximum antenna gain	Must not exceed antenna gain limits.	See Important Compliance Information for the United States on page 78 and Important Compliance Information for Canada on page 75 .
Isolation	<ul style="list-style-type: none"> B41: >20 dB between transmitting antennas UL MIMO: >20 dB (PC1.5, PC2, PC3) between transmitting antennas to avoid potential ACLR and EVM issues All antennas for all other bands/ scenarios: >10 dB 	<ul style="list-style-type: none"> To identify the transmitting antennas for any band, refer to Table 3-2 on page 41. If antennas can be moved, test all positions for both antennas. Make sure all other wireless devices (Bluetooth or WLAN antennas, etc.) are turned OFF to avoid interference.
Maximum input power at antenna port	<ul style="list-style-type: none"> ANT0 — 10 dBm ANT1 — 10 dBm (*0 dBm — see Comment) ANT2 — 10 dBm ANT3 — 10 dBm GNSS — 10 dBm 	*Important: GPS inband signal on ANT1 must be < 0 dBm to avoid damaging LNA.
Power handling	<ul style="list-style-type: none"> > 1 W 	<ul style="list-style-type: none"> Measure power endurance over 4 hours (estimated talk time) using a 1 W CW signal — set the CW test signal frequency to the middle of each supporting Tx band. Visually inspect device to ensure there is no damage to the antenna structure and matching components. VSWR/TIS/TRP measurements taken before and after this test must show similar results.

a. These worst-case VSWR figures for the transmitter bands may not guarantee RSE levels to be within regulatory limits. The device alone meets all regulatory emissions limits when tested into a cabled (conducted) 50 Ω system. With antenna designs with up to 2.5:1 VSWR or worse, the radiated emissions could exceed limits. The antenna system may need to be tuned in order to meet the RSE limits as the complex match between the module and antenna can cause unwanted levels of emissions. Tuning may include antenna pattern changes, phase/delay adjustment, and passive component matching. Examples of the application test limits would be included in FCC Part 22, Part 24 and Part 27, test case 4.2.2 for WCDMA (ETSI EN 301 908-1), where applicable.

A.2 Recommended GNSS Antenna Specifications

Table A-2: GNSS Antenna Requirements

Parameter	Requirements	Comments
Frequency range	<ul style="list-style-type: none"> GNSS L1: 1563–1587 MHz GNSS L5: 1164–1189 MHz GPS/QZSS L1: 1575.42 MHz \pm2 MHz GPS/QZSS L5: 1176 MHz \pm2 MHz Galileo E1: 1559–1591 MHz Galileo E5a: 1164–1189 MHz BeiDou B1C: 1559–1591 MHz BeiDou B1I: 1559–1563 MHz BeiDou B2a: 1166–1186 MHz GLONASS G1: 1593–1610 MHz NavIC L5: 1164–1189 MHz 	These ranges include a buffer zone to ensure coverage of the specific GNSS frequencies listed in Table 1-3 on page 11 .
Field of view (FOV)	<ul style="list-style-type: none"> Omni-directional in azimuth -45° to +90° in elevation 	
Polarization (average Gv/Gh)	> 0 dB	Vertical linear polarization is sufficient.
Free space average gain (Gv+Gh) over FOV	> -6 dBi (preferably > -3 dBi)	Gv and Gh are measured and averaged over -45° to +90° in elevation, and \pm 180° in azimuth.
Gain	<ul style="list-style-type: none"> Maximum gain and uniform coverage in the high elevation angle and zenith. Gain in azimuth plane is not desired. 	
Average 3D gain	> -5 dBi	
Isolation between GNSS and transmitting antennas	> 15 dB in all uplink bands and GNSS Rx bands	
Typical VSWR	< 2.5:1	
Polarization	Any other than LHCP (left-hand circular polarized) is acceptable.	
Active GNSS antenna	<ul style="list-style-type: none"> EM929X: Active antenna must not be used on shared path (ANT1). EM9293/EM9293P: Active antenna can be used on dedicated path (GNSS). 	Important: Do not connect an active antenna/DC presence to any of the shared antennas (ANT0–ANT3). Doing so will damage the module.

A.3 Sub-6 GHz Antenna Tests

The following guidelines apply to the requirements described in [Table A-1 on page 82](#) and [Table A-2 on page 84](#):

- Perform electrical measurements at room temperature (+20°C to +26°C) unless otherwise specified
- Make sure the antennas (including contact device, coaxial cable, receptacles, and matching circuit with no more than six components, if required) have nominal impedances of 50 Ω across supported frequency bands.
- All tests (except isolation/correlation coefficient)—Test the appropriate antenna with the other antennas terminated.

- Any metallic part of the antenna system that is exposed to the outside environment needs to meet the electrostatic discharge tests per IEC61000-4-2 (conducted discharge +8 kV).
- The functional requirements of the antenna system are tested and verified while the embedded module's antenna is integrated in the host device.

Note: Additional testing, including active performance tests, mechanical, and accelerated life tests can be discussed with Sierra Wireless' engineering services. Contact your Sierra Wireless representative for assistance.

B: Thermal Testing

B.1 Worst Case Testing

Sierra Wireless recommends that customers identify realistic worst-case conditions for their platforms and perform appropriate thermal testing.

For example:

- If the device has very good throughput, it is likely near a tower so will not have to transmit at maximum Tx output power.
- If the device is transmitting at maximum Tx power, it is likely not near a tower and will not reach maximum throughput rates.
- Networks usually are sharing capacity among many users, so no single user is likely to reach maximum throughput rates for any significant length of time.
- If the device is transmitting at maximum throughput, it will likely do so for a limited time to limit the amount of data usage consumed from their data plan.

B.2 Thermal Testing Process

To perform thermal testing of the module:

1. Mount the module in its designed location on the platform.
2. Provide the same amount of airflow as will be experienced in your platform.
3. Set the platform's ambient to the higher limit of the specification and observe the junction temperature ramp. (Use **AT!PCTEMP?**)
4. Set up a call with the use case for the platform (throughput rate, output power, duty cycle) on the worst-case band.
5. Observe the ramp in junction temperature due to the call, and confirm whether the overall system performance still meets customer requirements.
6. Use **AT!TMSTATUS?** to check the module's thermal mitigation status (refer to [1] *EM9 Series AT Command Reference (Doc# 41113480)* for details).
7. Increase the platform's ambient temperature to determine the margin that exists over the desired temperature specifications as subsequent mitigation methods activate (e.g. UL data rate throttled, DL throughput throttled (third and second CA dropped), UL power reduced, Emergency Service).

C: Production Testing

Note: All Sierra Wireless embedded modules are factory-tested to ensure they conform to published product specifications.

Developers of OEM devices integrating Sierra Wireless embedded modules should include a series of test phases in their manufacturing process to make sure their devices work properly with the embedded modules. For more information, refer to [5] *EM92 Customer Production Test Guide (Doc# 4 1 1 14569)*.

Sierra Wireless offers optional professional services-based assistance to OEMs with regulatory approvals.

D: Packaging

Sierra Wireless Embedded Modules are shipped in sealed boxes. The standard packaging (see [Figure D-1](#)), contains a single tray with a capacity of 100 modules.

In the standard packaging, Embedded Modules are inserted, system connector first, into the bottom portion (T1) of a two-part tray, all facing the same direction. This allows the top edge of each Embedded Module to contact the top of the triangular features in the top portion (T2) of the tray (Detail A).

The top and bottom portions of the tray snap together at the four connection points.

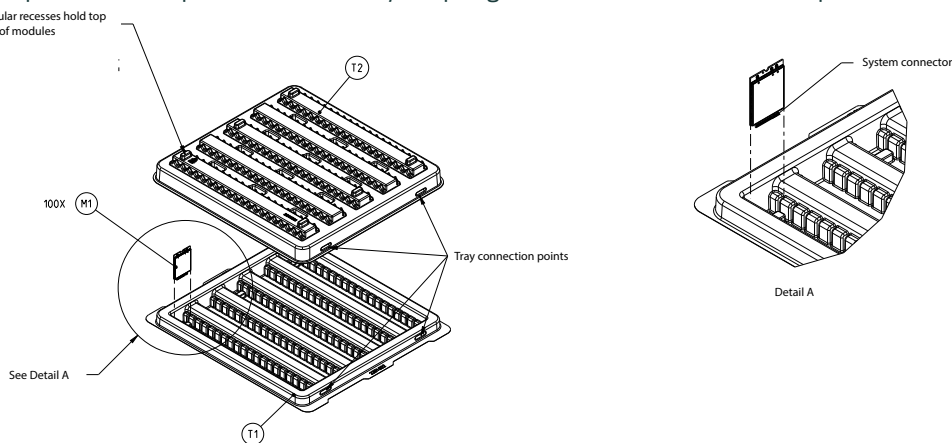

Figure D-1: Device Placement in Module Tray

The tray cover is secured to the tray base with ESD-safe tape (EP1) at the locations indicated. The tray is placed in a manufacturing box (B1), sealed with a security tape (P1), a manufacturing label (L3) is placed on the bottom-right corner, above the security tape, and if required a label (L4) is applied beside the manufacturing label. (See [Figure D-2](#).)

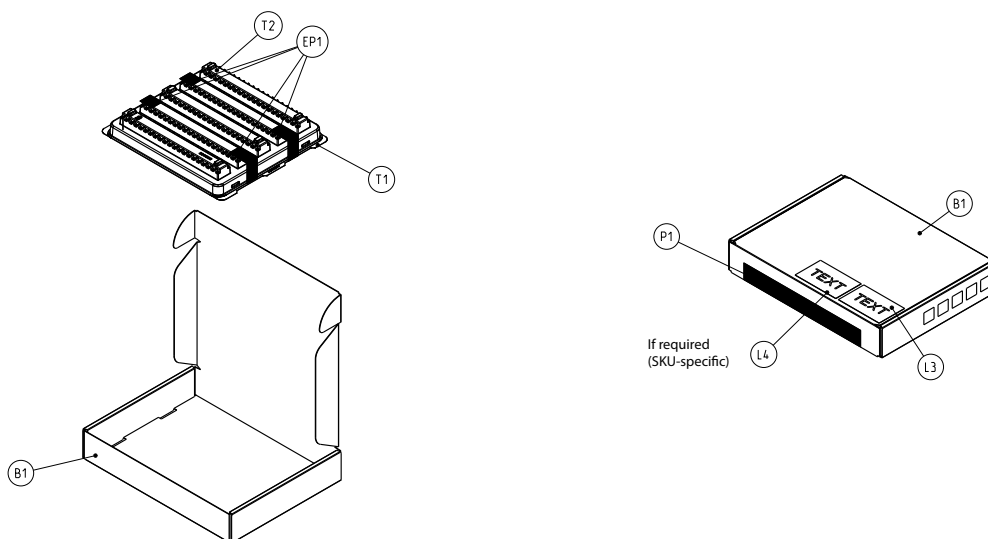

Figure D-2: Shipping Package

E: Design Checklist

This chapter provides a summary of the design considerations mentioned throughout this guide. This includes items relating to the power interface, RF integration, thermal considerations, cabling issues, and so on.

Note: This is NOT an exhaustive list of design considerations. It is expected that you will employ good design practices and engineering principles in your integration.

Table E-1: Hardware Integration Design Considerations

Suggestion	Section where discussed
Component Placement	
If an ESD suppressor is not used on the host device, allow space on the SIM connector for series resistors in layout. (Up to 100 Ω may be used depending on ESD testing requirements).	External SIM Interface Implementation on page 31
Minimize RF cable losses as these affect performance values listed in product specification documents.	RF Connections on page 42
Antennas	
Match the module/antenna coax connections to 50 Ω —mismatched antenna impedance and cable loss negatively affect RF performance.	RF Connections on page 42
If installing UMTS and CDMA modules in the same device, consider using separate antennas for maximum performance.	5G NR Sub-6 GHz/GNSS Antennas and Cabling on page 42
Power	
Make sure the power supply can handle the maximum current specified for the module type plus a margin of 50%.	Power Consumption on page 55
Limit the total impedance of VCC and GND connections to the SIM at the connector to less than 1 Ω (including any trace impedance and lumped element components—inductors, filters, etc.). All other lines must have a trace impedance less than 2 Ω .	External SIM Interface Implementation on page 31
Decouple the VCC line close to the SIM socket. The longer the trace length (impedance) from socket to module, the greater the capacitance requirement to meet compliance tests.	
PCB Signal Routing	
USB—Route the USB interface signals over 90 Ω differential lines on the PCB.	
PCIe Gen3—Route the data and clock differential pairs over 90 Ω differential lines on the PCB.	
EMI / ESD	
Investigate sources of localized interference early in the design cycle.	Methods to Mitigate Decreased Rx Performance on page 44
Provide ESD protection for the SIM connector at the exposed contact point (in particular, the CLK, VCC, IO, and RESET_N lines).	External SIM Interface Implementation on page 31
Keep very low capacitance traces on the UIM_DATA and UIM_CLK signals.	

Table E-1: Hardware Integration Design Considerations (Continued)

Suggestion	Section where discussed
To minimize noise leakage, establish a very good ground connection between the module and host.	Ground Connection on page 43
Route cables away from noise sources (for example, power supplies, LCD assemblies, etc.).	Methods to Mitigate Decreased Rx Performance on page 44
Shield high RF-emitting components of the host device (for example, main processor, parallel bus, etc.).	
Use discrete filtering on low frequency lines to filter out unwanted high-order harmonic energy.	
Use multi-layer PCBs to form shielding layers around high-speed clock traces.	
Thermal	
Test to worst case operating conditions — temperature, voltage, and operation mode (transmitter on 100% duty cycle, maximum power).	Thermal Considerations on page 73
Use appropriate techniques to reduce module temperatures (for example, airflow, heat sinks, heat-relief tape, module placement, etc.).	

F: References

F.1 Sierra Wireless Documents

Sierra Wireless documents are available from source.sierrawireless.com, or on request (subject to license agreements or NDAs) from your Sierra Wireless representative.

Important: *Documents that are listed as applying specifically to EM91 Series modules (e.g., E9190, EM919x, EM7690, etc.) will be updated or replaced to include EM92 Series module content.*

Sierra Wireless Documents on the Source

The following documents are available from source.sierrawireless.com:

- [1] EM9 Series AT Command Reference (Doc# 41113480)
- [2] Sierra Wireless EM919x/EM7690 Development Kit User Guide (Doc# 41113875)
- [3] EM9190 Thermal Application Note (Doc# 2174257)
- [4] EM92XX Thermal Mitigation Application Note (Doc# 2174346)
- [5] EM92 Customer Production Test Guide (Doc# 41114569)
- [6] EM9190 Current Consumption Application Note (Doc# 2174287)
- [7] EM919x/EM7690 PCIe Integration Guide (Doc# 41114276)
- [8] Software Integration and Development Guide for Linux USB Platforms (Doc# 41114212)
- [9] EM9 Series Secure Boot (Doc# 2174333 (Forthcoming))
- [10] EM9 Series Secure Debug (Doc# 2174334 (Forthcoming))
- [11] EM929x Smart Transmit (Doc# 2174327)

Sierra Wireless Documents Requiring License Agreement

The following documents are available under license agreement — contact your Sierra Wireless representative:

- [12] Software Integration and Development Guide for Linux Platforms (Doc# 41113764)
- [13] Mobile Broadband Package for Linux Release Notes (Doc# 41113802)
- [14] Mobile Broadband Package for Android Release Notice (Doc# 41114274)

Sierra Wireless Documents Requiring NDA

The following documents are available under NDA — contact your Sierra Wireless representative:

- [15] EM9 Carrier Aggregations and EN-DC (Doc# 2174317)

For additional documents that may be used (under NDA) to assist with regulatory and certification submissions, contact your Sierra Wireless representative.

F.2 Industry/Other Documents

The following referenced document are not provided by Sierra Wireless:

- [16] AT Command Set for User Equipment (UE) (Release 6) (Doc# 3GPP TS 27.007)
- [17] FCC Regulations - Part 15 - Radio Frequency Devices

-
- [18] IEC-61000-4-2 level 3 (Electrostatic Discharge Immunity Test)
 - [19] Mobile Station (MS) Conformance Specification; Part 4: Subscriber Interface Module (Doc# 3GPP TS 11.10-4)
 - [20] PCI Express M.2™ Specification Revision 4.0, Version 1.1
 - [21] Universal Serial Bus 3.2 Specification, Revision 1.1
 - [22] JESD22-A114-B
 - [23] JESD22-C101
 - [24] MIPI Alliance Specification for RF Front-End Control Interface

G: Abbreviations

Table G-1: Abbreviations and Definitions

Abbreviation or Term	Definition
3GPP	3rd Generation Partnership Project
8PSK	Octagonal Phase Shift Keying
A-GPS	Assisted GPS
ACLR	Adjacent channel leakage ratio
AGC	Automatic Gain Control
API	Application Programming Interface
BDS	See BeiDou
BeiDou	BeiDou Navigation Satellite System A Chinese system that uses a series of satellites in geostationary orbit and Medium Earth Orbit (MEO) to provide navigational data.
BER	Bit Error Rate—A measure of receive sensitivity
BLER	Block Error Rate
Bluetooth	Wireless protocol for data exchange over short distances
COM	Communication port
CPC	Continuous Packet Connectivity
CPE	Customer-Premises Equipment
CQI	Channel Quality Indication
CS	Circuit Switched
CSG	Closed Subscriber Group
CW	Continuous waveform
dB	Decibel = $10 \times \log_{10} (P1/P2)$ <i>P1 is calculated power; P2 is reference power</i> Decibel = $20 \times \log_{10} (V1/V2)$ <i>V1 is calculated voltage, V2 is reference voltage</i>
dBm	A logarithmic (base 10) measure of relative power (dB for decibels); relative to milliwatts (m). A dBm value will be 30 units (1000 times) larger (less negative) than a dBW value, because of the difference in scale (milliwatts vs. watts).
DC-HSPA+	Dual Carrier HSPA+
DCS	Digital Cellular System A cellular communication infrastructure that uses the 1.8 GHz radio spectrum.
DL	Downlink (network to mobile)
DPCH	Dedicated Physical Channel

Table G-1: Abbreviations and Definitions (Continued)

Abbreviation or Term	Definition
DRX	Discontinuous Reception
DSM	Distributed Shared Memory
DSSS	Dual SIM Single Standby — User selects which of two SIMs (external SIM (UIM1) or eSIM (UIM2)) is active.
DTX	Discontinuous Transmission
DUT	Device Under Test
E-FACH	Enhanced Cell Forward Access Channel
EGNOS	European Geostationary Navigation Overlay Service (SBAS for GPS, GLONASS, Galileo)
eICIC	Enhanced Inter-Cell Interference Coordination
EIRP	Effective (or Equivalent) Isotropic Radiated Power
EMC	Electromagnetic Compatibility
EMI	Electromagnetic Interference
ENDC	E-UTRAN New Radio — Dual Connectivity
EP	End Point
ERP	Effective Radiated Power
ESD	Electrostatic Discharge
EVM	Error vector magnitude
FCC	Federal Communications Commission The U.S. federal agency that is responsible for interstate and foreign communications. The FCC regulates commercial and private radio spectrum management, sets rates for communications services, determines standards for equipment, and controls broadcast licensing. Consult www.fcc.gov .
FDD	Frequency Division Duplexing (Spectrum usage technique where uplink and downlink are carried on different frequencies)
FDMA	Frequency Division Multiple Access
F-DPCH	Fractional DPCH
feICIC	Further Enhanced Inter-Cell Interference Coordination
FER	Frame Error Rate — A measure of receive sensitivity.
firmware	Software stored in ROM or EEPROM; essential programs that remain even when the system is turned off. Firmware is easier to change than hardware but more permanent than software stored on disk.
FOTA	Firmware Over The Air — Technology used to download firmware upgrades directly from the service provider, over the air.
FOV	Field Of View

Table G-1: Abbreviations and Definitions (Continued)

Abbreviation or Term	Definition
FPC	Flexible Printed Cable
FSN	Factory Serial Number—A unique serial number assigned to the module during manufacturing.
Galileo	A European system that uses a series of satellites in Medium Earth Orbit (MEO) to provide navigational data.
GCF	Global Certification Forum
GLONASS	Global Navigation Satellite System —A Russian system that uses a series of 24+ satellites in Medium Earth Orbit (MEO) to provide navigational data.
GMSK	Gaussian Minimum Shift Keying modulation
GNSS	Global Navigation Satellite Systems (GPS, QZXX, GLONASS, BeiDou, and Galileo)
GPS	Global Positioning System An American system that uses a series of 24–32 satellites in Medium Earth Orbit (MEO) to provide navigational data.
HB	High Band
Host	The device into which an embedded module is integrated
HSDPA	High Speed Downlink Packet Access
HS-FACH	High Speed Forward Access Channel
HSPA+	Enhanced HSPA, as defined in 3GPP Release 7 and beyond
HSUPA	High Speed Uplink Packet Access
Hz	Hertz = 1 cycle/second
IC	Industry Canada
IF	Intermediate Frequency
IMEI	International Mobile Equipment Identity
IMS	IP Multimedia Subsystem — Architectural framework for delivering IP multimedia services.
inrush current	Peak current drawn when a device is connected or powered on
inter-RAT	Radio Access Technology
IOT	Interoperability Testing
IS	Interim Standard. After receiving industry consensus, the TIA forwards the standard to ANSI for approval.
ISED	Innovation, Science and Economic Development Canada (formerly Industry Canada (IC))
ISIM	IMS Subscriber Identity Module (Also referred to as a SIM card)
LAA	Licensed Assisted Access
LB	Low Band

Table G-1: Abbreviations and Definitions (Continued)

Abbreviation or Term	Definition
LED	Light Emitting Diode. A semiconductor diode that emits visible or infrared light.
LHCP	Left-Hand Circular Polarized
LNA	Low Noise Amplifier
LPM	Low Power Mode
LPT	Line Print Terminal
LTE	Long Term Evolution—a high-performance air interface for cellular mobile communication systems.
MB	Mid Band
MCS	Modulation and Coding Scheme
MEO	Medium Earth Orbit
MHz	Megahertz = 10e6 Hz
MIMO	Multiple Input Multiple Output—wireless antenna technology that uses multiple antennas at both transmitter and receiver side. This improves performance.
MPR	Maximum Power Reduction
MSAS	Multi-functional Satellite Augmentation System (SBAS for GPS)
NAS/AS	Network Access Server
NavIC	Navigation with Indian Constellation An Indian regional navigation system that uses a series of 7 satellites in geostationary orbit to provide navigational data.
NC	No Connect
NIC	Network Interface Card
NLIC	Non-Linear Interference Cancellation
NMEA	National Marine Electronics Association
NSA	5G Non-standalone architecture
ODM	Original Design Manufacturer
OEM	Original Equipment Manufacturer—a company that manufactures a product and sells it to a reseller.
OFDMA	Orthogonal Frequency Division Multiple Access
OMA DM	Open Mobile Alliance Device Management—A device management protocol.
OTA	'Over the air' (or radiated through the antenna)
PA	Power Amplifier
packet	A short, fixed-length block of data, including a header, that is transmitted as a unit in a communications network.

Table G-1: Abbreviations and Definitions (Continued)

Abbreviation or Term	Definition
PCB	Printed Circuit Board
PCC	Primary Component Carrier
PCS	Personal Communication System A cellular communication infrastructure that uses the 1.9 GHz radio spectrum.
PDN	Packet Data Network
PMI	Pre-coding Matrix Index
PRX	Primary Reception
PS	Packet Switched
PSS	Primary synchronization signal
PST	Product Support Tools
PTCRB	PCS Type Certification Review Board
QAM	Quadrature Amplitude Modulation. This form of modulation uses amplitude, frequency, and phase to transfer data on the carrier wave.
QCI	QoS Class Identifier
QMI	Qualcomm MSM/Modem Interface
QOS	Quality of Service
QPSK	Quadrature Phase-Shift Keying
QPST	Qualcomm Product Support Tools
QZSS	Quasi-Zenith Satellite System — Japanese system for satellite-based augmentation of GPS.
RAB	Radio Access Bearer
RAT	Radio Access Technology
RC	Root Complex
RF	Radio Frequency
RI	Ring Indicator
roaming	A cellular subscriber is in an area where service is obtained from a cellular service provider that is not the subscriber's provider.
RSE	Radiated Spurious Emissions
RSSI	Received Signal Strength Indication
S/N	Signal-to-noise (ratio)
SA	5G Standalone architecture
SAR	Specific Absorption Rate

Table G-1: Abbreviations and Definitions (Continued)

Abbreviation or Term	Definition
SBAS	Satellite-based Augmentation System
SCC	Secondary Component Carrier
SCS	Subcarrier Spacing
SDK	Software Development Kit
SDL	Supplementary Downlink (Downlink-only frequency band providing additional carrier aggregation capacity)
SED	Smart Error Detection
Sensitivity (Audio)	Measure of lowest power signal that the receiver can measure.
Sensitivity (RF)	Measure of lowest power signal at the receiver input that can provide a prescribed BER/BLER/SNR value at the receiver output.
SG	An LTE signaling interface for SMS (“SMS over SGs”)
SIB	System Information Block
SIM	Subscriber Identity Module. Also referred to as USIM or UICC.
SIMO	Single Input Multiple Output—smart antenna technology that uses a single antenna at the transmitter side and multiple antennas at the receiver side. This improves performance and security.
SISO	Single Input Single Output—antenna technology that uses a single antenna at both the transmitter side and the receiver side.
SKU	Stock Keeping Unit—identifies an inventory item: a unique code, consisting of numbers or letters and numbers, assigned to a product by a retailer for purposes of identification and inventory control.
SMS	Short Message Service. A feature that allows users of a wireless device on a wireless network to receive or transmit short electronic alphanumeric messages (up to 160 characters, depending on the service provider).
SNR	Signal-to-Noise Ratio
SOF	Start of Frame — A USB function.
SRB	Signaling Radio Bearer
SSS	Secondary synchronization signal.
SUPL	Secure User Plane Location
TD-SCDMA	Time Division Synchronous Code Division Multiple Access
TDD	Time Division Duplexing (Spectrum usage technique where single frequency is used for alternating uplink and downlink)
TIA/EIA	Telecommunications Industry Association / Electronics Industry Association. A standards setting trade organization, whose members provide communications and information technology products, systems, distribution services and professional services in the United States and around the world. Consult www.tiaonline.org .
TIS	Total Isotropic Sensitivity

Table G-1: Abbreviations and Definitions (Continued)

Abbreviation or Term	Definition
TRP	Total Radiated Power
TRX	Transceiver Transmits and receives signals
UDK	Universal Development Kit (for PCI Express Mini Cards)
UE	User Equipment
UHB	Ultra-High Band
UICC	Universal Integrated Circuit Card (Also referred to as a SIM card.)
UL	Uplink (mobile to network)
UMTS	Universal Mobile Telecommunications System
USB	Universal Serial Bus
USIM	Universal Subscriber Identity Module (UMTS)
VCC	Supply voltage
VDC	Volts DC
VSWR	Voltage Standing Wave Ratio
WAAS	Wide Area Augmentation System (SBAS for GPS)
WAN	Wide Area Network
WCDMA	Wideband Code Division Multiple Access (also referred to as UMTS)
WLAN	Wireless Local Area Network
ZIF	Zero Intermediate Frequency
ZUC	ZUC stream cypher

H: Revision History

Rev #	Release date	Changes
0.1	August 2022	Document creation, preliminary release
0.2	December 2022	<p>Removed 'auxiliary' antenna references Added notes — Commercially deployed systems must have all four antennas enabled. Simplified Table 1-2 RF Band Support Added Table 1-3 GNSS Frequency Support Updated 1.2 Mechanical Features Updated 1.6 LTE Features (B43 HPUE) Updated Table 3-1 Host Interface (75-pin) Connections — Module View (UIM2_PRES/SIM1_DETECT active state) Updated 3.3 USB Interface (USB 3.2 spec) Updated 3.5 SIM Interface (Added second external SIM) Updated 3.8 Tx Power Control Updated Table 4-1 Antenna Connectors — RF Technology Support Removed 4.2.1.2 Designing Customer Sub-6G Antennas Updated Table 4-5 Supported Frequency Bands, by RAT (5G NR/LTE/3G) (removed 3G B6) Updated Table 4-7 5G NR Bandwidth and 5G Architecture Support Updated 4.8 Supported RATs (Added cross-reference for CA-EN-DC appnote) Updated 4.8.2 CA/EN-DC Support (Removed tables) Updated Table 4-16 EM9293 Typical Conducted Rx Sensitivity — NR Bands Updated Table 4-17 EM9293 Typical Conducted Rx Sensitivity — LTE Bands at 10 MHz BW Updated Table 4-18 EM9293 Typical Conducted Rx Sensitivity — UMTS Bands Updated Table 4-19 EM9293 Conducted Maximum Tx Power Tolerances Updated Table 5-7 EM9293 Averaged Standby DC Power Consumption (leakage current) Updated Table 7-1 Mechanical and Environmental Specifications Replaced Figure 7-9, Figure 7-2, Figure 7-3 Updated Table 8-1 Antenna Gain and Collocated Radio Transmitter Specifications (added n70) Updated Table A-1 Antenna Requirements Updated Table A-2 GNSS Antenna Requirements Updated A.3 Sub-6 Antenna Tests (replaced main/diversity wording) Updated F References</p>
0.3	April 2023	<p>Added EM9290, EM9293 Updated terminology (antenna connectors → antenna receptacles) Updated Table 1-1 (reformatted, updated GNSS footnotes) Updated Table 1-2 (added 5G mmW band support) Updated Table 1-3 (reformatted, added antenna names) Updated Table 1-3 (added antenna names) Updated Host Interface Features (updated Operating systems; added SIM support, Debug interface) Updated Modem Features (updated SIM support entry) Updated 5G Features (added mmW-related content; updated Network options detail, MIMO table) Updated LTE Features (added MIMO footnote)</p> <p><i>(Continued on next page)</i></p>

Rev #	Release date	Changes
0.3	April 2023	<p><i>(Continued from previous page)</i></p> <p>Updated Position Location (GNSS) (added antenna names) Updated Table 1-4 (RF entries) Updated Electrical Specifications introduction (Antennas and SIMs entries) Updated Table 3-1 (general update— updated pins 1, 7–9, 21–23, 25, 26, 28, 29, 31, 34, 35, 37, 38, 40–44, 46–50, 53, 55, 56, 58, 59, 61, 63, 65, 67, 69, 75; updated footnotes) Updated PCIe Host-side Recommendation (series capacitors required) Updated Table 3-5 (added Module; updated Details) Updated Figure 3-3 (added notes) Updated Table 3-9 (updated RESET_N description and timing) Added WWAN_LED_N— LED Output (updated behavior description) Added PCIE_DIS— Interface Selection Added mmW Antenna Module Power Control Updated Antenna Control (added RFFE content) Added Module Configuration Updated Antenna Receptacles, 5G NR Sub-6G/LTE/WCDMA/GNSS Receptacles Added 5G NR mmW Receptacles Updated RF Connections Updated Table 4-4 (reformatted; added n48) Updated Table 4-5 (added mmW bands) Updated Table 4-7 (updated bandwidth details for n7, n8, n25, n38, n40, n66, n70, n71, n77, n78, n257, n258, n260, n261) Updated Power Consumption (added power supply recommendation) Updated Table 5-2 (set values to TBD) Updated Table 5-5 (updated footnote a; set temperature triggers as TBD) Updated Table 5-6 (updated PCIe timing values; added T_perst_link_ok) Updated Table 5-7 (updated USB timing values) Updated Required Shutdown Sequence (updated power off process timing note) Updated Table 7-1 (updated ESD non-operational content) Updated Device Views (all figures) Updated Thermal Considerations Updated Electrostatic Discharge (ESD) (added mmW statement) Updated Regulatory Compliance and Industry Certifications (added EM9290, EM9293) Updated Table A-1 (added dedicated GNSS antenna for EM9293) Updated Table A-2 (updated Frequency range and Active antenna Requirements) Added mmW Modules</p>
0.4	August 2023	<p>Removed EM9290 Updated device images throughout document Added WCDMA Features Updated Table 3-1 (pins 6/20 voltage levels) Updated Table 4-2 (n77/n78 alternate path Tx) Updated Table 4-6 (n1/n18/n25/n38/n41/n48/n71/n79) Updated Table 4-10 (LTE B2/B4/B5/B13/B66)</p> <p><i>(Continued on next page)</i></p>

Rev #	Release date	Changes
0.4	August 2023	<p><i>(Continued from previous page)</i></p> <p>Updated W_DISABLE_N references to include Dying Gasp feature Replaced Table 5-1 with separate USB/PCI tables (Table 5-1/ Table 5-2, including values) Updated Figure 5-2/ Table 5-8 (removed T_perst_link_ok; updated figure callout for PCIE_DIS) Updated Table 7-1 (added MTBF) Updated Figure 7-6/ Figure 7-7 (removed RF component)</p>
0.5	August 2023	<p>Marked LTE B30 as DL only Updated Table 4-2 (n77/n78 alternate path Tx) Updated Table 4-10 (5G Conducted Tx power tolerances) Updated Table 5-3 EM9291 Averaged Call Mode DC Power Consumption</p>
1	October 2023	<p>Updated 5G FR1 Features (removed UL CA statement) Updated Table 5-3 (removed TBD references) Updated Table 5-4 (removed TBD references) Updated Table 5-8 (updated T_pwr_off_seq values) Updated Figure 7-5 (label includes CPN in Data Matrix format) Separated 8.3 Important Compliance Information for the United States and Canada into Important Compliance Information for the United States and Important Compliance Information for the United States, updated wording, updated antenna gain value tables (Table 8-1, Table 8-2)</p>
2	April 2024	<p>Reformatted document to Semtech template Added BeiDou B1C Updated Position Location (GNSS) on page 15 (EM9293 active bias for external LNA) Removed chapter 2: Standards Compliance; renumbered remaining chapters Added Figure 2-1 (System Block Diagram) Updated Table 2-1 Host Interface (75-pin) Connections — Module View (pin descriptions 1, 21, 69, 75) Updated 2.8 Tx Power Control (updated DPR GPIO configuration description) Updated 2.9 Antenna Control (removed inapplicable note) Updated Table 3-2 (added footnotes for Tx Antennas and Rx Antennas) Added Table 3-2 5G NR Sub-6/LTE/WCDMA/GNSS Antenna Receptacles — RF Technology Support Updated Table 3-7 (architecture acronyms; n13, n18, n26, n41, n70; footnotes c, d) Updated Table 3-9 (B32, B71) Updated Table 3-11 (footnote c; 5G and LTE sections) Updated Table 4-4 (LTE configuration descriptions — added layers) Updated Table 6-1 (Ambient storage temperature Storage details — added RH %) Restructured chapter 7 Regulatory Compliance and Industry Certifications</p>
3	May 2024	<p>Updated 1.6 LTE Features (added missing B38 4x4 MIMO entry) Updated Table 3-4 (n38 SRS_T2_R4 support) Updated Table 3-8 (sensitivity values, worst case limits) Updated Table 3-9 (sensitivity values, worst case limits) Updated Table 3-11 (5G notes for n41/n77/n78/n79 entry) Added NavIC (Table 1-3, 1.9 Position Location (GNSS), 3.8 Supported RATs, Table A.2)</p>

Rev #	Release date	Changes
4	September 2024	<p>Clarified notes regarding connection requirements for ANTO-ANT3 and GNSS antennas in 2 Electrical Specifications (Antenna Receptacles), 5G NR Sub-6 GHz/LTE/WCDMA/GNSS Receptacles, RF Connections, Disabling the Diversity Antenna.</p> <p>Removed 'upon commercial release' statements in Regulatory Compliance and Industry Certifications.</p> <p>Updated Table 2-1, Host Interface (75-pin) Connections — Module View (VBUS_SENSE min voltage)</p> <p>Updated Table 2-9, Full_Card_Power_Off_N and RESET_N Usage (RESET_N notes)</p> <p>Updated Tx Power Control (updated configuration via GPIO; Table 2-10, DPR Logic)</p> <p>Updated Antenna Control (added n71/B71 usage details)</p> <p>Updated 5G NR Bandwidth and 5G Architecture Support (removed SRS_T1_R4)</p> <p>Updated Table 7-1, ISED Antenna Gain and Collocated Radio Transmitter Specifications and Table 7-2, FCC Antenna Gain and Collocated Radio Transmitter Specifications (removed Max Cond Power values)</p>
5	January 2025	<p>Added B106 support</p> <p>Added pin usage footnotes for VCC pins to Table 2-1 and Table 2-2</p> <p>Updated Table 3-2 (updated LTE B42,43,48 Tx antennas)</p> <p>Updated Table 3-11 (added footnote 'c' regarding maximum power reduction)</p>
6	March 2025	<p>Added 3V UIM2 notes/pin details (updated Introduction; updated Table 2-1 Host Interface (75-pin) Connections — Module View; updated Table 2-5: Supported SIMs; updated 2.5.1 External SIM Interface Implementation)</p> <p>Added PCIe interface reset notes/pin details (updated Table 2-4: PCIe Interface; added 2.4.3 PCIE_PERST_N; updated Table 2-9: Full_Card_Power_Off_N and RESET_N Usage; updated 4.3.2.1 Power On/Off Timing for PCIe Port)</p> <p>Updated Table 3-4: SRS 5G NR Sub-6 GHz Band Support (updated SRS_T1_R4; added Notes)</p> <p>Updated Table 3-12: GNSS Specifications (added dedicated GNSS path sensitivity)</p>
7	July 2025	<p>Added EM9291P and EM9293P variants</p> <p>Updated 1.5 5G FR1 Features (added PC1.5, 5G NR Sub-6 GHz UL (SA))</p> <p>Updated Table 2-2 (removed peak current and continuous current)</p> <p>Updated 3.8 Supported RATs (added 5G NR Sub-6 GHz UL (SA))</p> <p>Updated Table 3-11 (added PC1.5 power tolerance)</p> <p>Updated Table 4-3 (added PC1.5 case)</p> <p>Updated Table 4-4 (added PC1.5 case)</p> <p>Updated Table 4-5 (added continuous current and PC1.5 peak current)</p> <p>Added 4.1.1 Peak Current Mitigation</p> <p>Updated 7 Regulatory Compliance and Industry Certifications (added EM9291P and EM9293P grant numbers and gain table details)</p>
7.1	March 2026	Updated Figure 2-1 (corrected memory size)