

Author	Sierra Wireless				Date	September 4, 2020			
APN Content Level	BASIC	INTERMEDIATE	✓	ADVANCED	Confidentiality	Public	✓	Private	
Hardware Compatibility	Product Line	EM	Series	EM9190					
Software Compatibility	ALL								



## 1 Version

The application notes may be updated over their lifetime. To ensure you design with the correct version, please check the application notes page in [www.sierrawireless.com](http://www.sierrawireless.com) for the latest versions.

## 2 Introduction

This application note is provided to Sierra Wireless distributors and clients to aid more rapid development of embedded applications using the Sierra Wireless portfolio of cellular solutions. To request a new application note, contact your regional Sierra Wireless Product Marketing Manager.

The values listed in this document are from measurements of a typical EM9190 module using RF callboxes in lab, while the consumption value on live network in field may differ due to additional radioactivity and/or variations of actual network status.

As EM9191/EM7690 products share common hardware and software design with EM9190, their current consumption can be fully leveraged from EM9190 measurement values.

## 3 Document Scope

This application note proposes the AirPrime EM9190 current consumption.

The information is provided to help customers develop their own current consumption and thermal design.

## 4 Current Consumption Information

### 4.1 Current Consumption Model

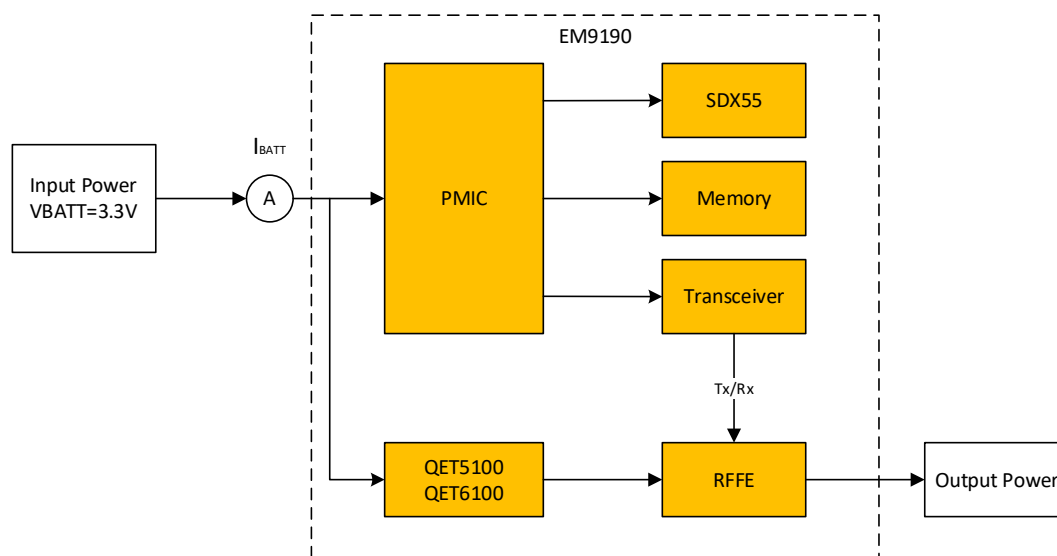

Figure 1 Current Consumption Model

## 4.2 Test Setup

Hardware and software are used for measurement (for Sub-6 EN-DC only):

- EM9190 DV4 samples with recommended heatsink (Refer to [AirPrime EM9190 Thermal Application Note - Rev2.0](#) for details.)
- Keysight 66311B power supply which provides 3.3V input power
- Anritsu MT8000A + MT8821C x 3
- RF dividers and cables
- FW version, SWIX55C\_00.16.06.00-LXSWI2.7\_1.0\_EM919x.r1\_13.06

The following test setup is for maximum UL/DL throughput of Sub-6 EN-DC mode. Lower throughput may need less combination of below materials. For example, to test Sub-6 1CC + LTE 4CC, 4 x 4 MIMO, one MT8000A and two MT8821C are required.



Figure 2 Test Sample and Heatsink (bottom aluminum heatsink 75X74.5X12 mm, area 31005 mm<sup>2</sup>)

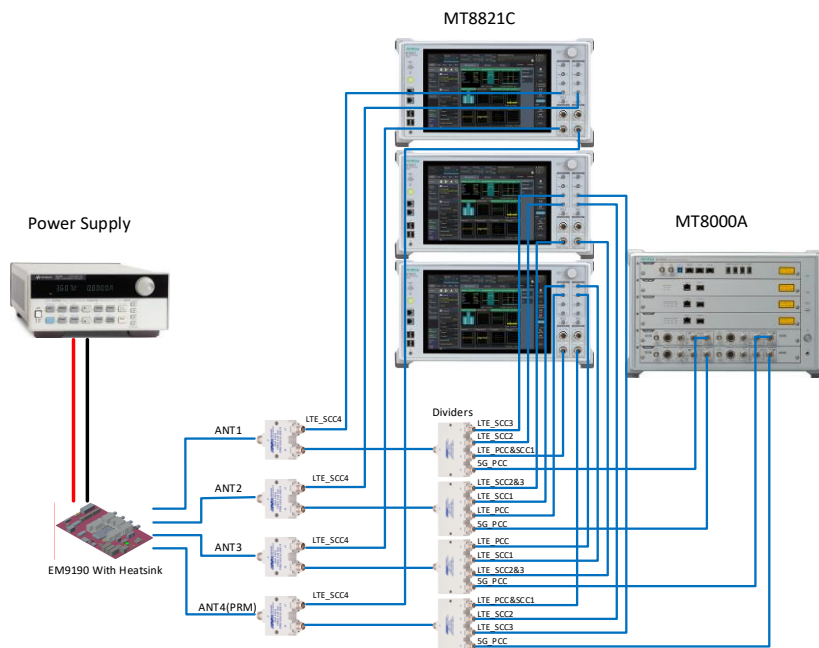

Figure 3 Sub-6 NSA 1CC + LTE 5CC, 4x4 MIMO

## 5 Measurement Value

These values are normalized to a 3.3V supply voltage. All values listed in this document are from measurements of a typical EM9190 module using a callbox in lab.

### 5.1 Off Current

Power off unit, keep VBATT connection, remove USB cable, and measure the leakage current consumption.

Table 1. Averaged Current, Off Mode

Mode	Configuration	-40°C	25°C	85°C	Unit
Off Current	Power off unit, VBATT ON, without USB	45	48	85	μA

### 5.2 Airplane Current

Enable airplane mode by AT command AT+CFUN=0, USB and PCIe fully suspended, sleep mode currents are measured with AT+SLEEP=1, while non-sleep mode currents are measured with AT+SLEEP=0.

Table 2. Averaged Current, Airplane Mode

Mode	Configuration	-40°C	25°C	85°C	Unit	
Airplane	Sleep Mode	USB and PCIe suspended, AT+CFUN=0, AT+SLEEP=1	1.3	1.7	5.2	mA
	Non-Sleep Mode	USB and PCIe suspended, AT+CFUN=0, AT+SLEEP=0	-	16.4	-	mA

### 5.3 Standby Current

Set callbox DRX cycles based on operating bands (WCDMA = 2.56s, LTE = 1.28s, Sub-6 = 1.28s ), attach to network, USB and PCIe fully suspended, sleep mode currents are measured with AT+SLEEP=1, while non-sleep mode currents are measured with AT+SLEEP=0.

Table 3. Averaged Current, Standby Mode

Mode	Configuration	-40°C	25°C	85°C	Unit	
WCDMA Standby	Sleep Mode	DRX cycle = 2.56s	2.2	2.6	6.0	mA
	Non-sleep Mode	DRX cycle = 2.56s	-	18.7	-	mA
LTE Standby	Sleep Mode	DRX cycle = 1.28s	2.4	2.8	7.9	mA
	Non-sleep Mode	DRX cycle = 1.28s	-	19.9	-	mA
Sub-6 Standby	Sleep Mode	DRX cycle = 1.28s	2.5	2.7	7.2	mA
	Non-sleep Mode	DRX cycle = 1.28s	-	19.6	-	mA

### 5.4 OnCall Current

Set UE with target RF power, data connection with specific DL/UL throughput, make a call and measure the current consumption.

*Note:* The maximum current consumption for each mode occurs under +70°C ambient temperature, which guarantees full UL/DL performance, however under +85°C, Tx power backoff and/or Rx throughput fallback may happen due to thermal mitigation actions.

*EM9191 equivalent capability was up to below Sub-6 1CC + LTE 3CC (12 layers LTE).*

*EM7690 equivalent capability was up to below LTE FDD 5CC DL 4x4 /2CC UL (20 layers LTE).*

**Table 4. Averaged Current, Data Call, RF Tx Power 0 dBm and 23 dBm**

Mode	Configuration	Tx Power (dBm)	Bands	25°C	70°C	Unit
3G Data Call	HSDPA DL 7.2 Mbps	0	B3	250	310	mA
		23	B3	800	890	mA
LTE FDD 1CC DL 4x4 /1CC UL	DL 400 Mbps/ UL 100Mbps, FDD, 20MHz/CC. Rx: 1CC,4x4 MIMO, 256 QAM, RB=100, MCS=27; Tx: 1CC, 0dBm, 256QAM	0	1A	275	349	mA
	DL 400 Mbps/ UL 1 Mbps, FDD, 20MHz/CC. Rx: 1CC,4x4 MIMO, 256 QAM, RB=100, MCS=27; Tx: 1CC, 23dBm, QPSK	23	1A	725	890	mA
LTE FDD 2CC DL 4x4 /1CC UL	DL 800 Mbps/ UL 100Mbps, FDD, 20MHz/CC. Rx: 2CC,4x4 MIMO, 256 QAM, RB=100, MCS=27; Tx: 1CC, 0dBm, 256QAM	0	1A+3A	450	530	mA
	DL 800 Mbps/ UL 1 Mbps, FDD, 20MHz/CC. Rx: 2CC,4x4 MIMO, 256 QAM, RB=100, MCS=27; Tx: 1CC, 23dBm, QPSK	23	1A+3A	890	1060	mA
LTE FDD 3CC DL 4x4 /1CC UL	DL 1200 Mbps/ UL 100Mbps, FDD, 20MHz/CC. Rx: 3CC,4x4 MIMO, 256 QAM, RB=100, MCS=27; Tx: 1CC, 0dBm, 256QAM	0	1A+3A+7A	585	670	mA
	DL 1200 Mbps/ UL 1 Mbps, FDD, 20MHz/CC. Rx: 3CC,4x4 MIMO, 256 QAM, RB=100, MCS=27; Tx: 1CC, 23dBm, QPSK	23	1A+3A+7A	975	1160	mA
LTE FDD 4CC DL 4x4 /1CC UL	DL 1600 Mbps/ UL 100Mbps, FDD, 20MHz/CC. Rx: 4CC,4x4 MIMO, 256 QAM, RB=100, MCS=27; Tx: 1CC, 0dBm, 256QAM	0	1A+3A+7C	690	750	mA
	DL 1600 Mbps/ UL 1 Mbps, FDD, 20MHz/CC. Rx: 4CC,4x4 MIMO, 256 QAM, RB=100, MCS=27; Tx: 1CC, 23dBm, QPSK	23	1A+3A+7C	1170	1280	mA
LTE FDD 5CC DL 4x4 /2CC UL	DL 2000 Mbps/ UL 200Mbps, FDD, 20MHz/CC. Rx: 5CC,4x4 MIMO, 256 QAM, RB=100, MCS=27; Tx: 2CC, 0dBm, 256QAM	0	1A+3C+7C	905	1010	mA
	DL 2000 Mbps/ UL 1 Mbps, FDD, 20MHz/CC. Rx: 5CC,4x4 MIMO, 256 QAM, RB=100, MCS=27; Tx: 2CC, 23dBm, QPSK	23	1A+3C+7C	1440	1540	mA
Sub-6 1CC + LTE 1CC	DL 2000 Mbps/UL 200Mbps. Sub-6 100 MHz/CC, DL/UL duty cycle ~80/20, Rx: 1CC, 4 x4 MIMO, -50dBm, 256QAM, RB=273, MCS=27; Tx: -3dBm SISO, 256QAM1; LTE: DL 1CC, 4 x4 MIMO,20 MHz/CC, 256 QAM, RB=100, MCS=27; Tx: -3dBm SISO 256QAM.	0	1A+N78	840	980	mA
	DL 2000 Mbps/UL 1 Mbps. Sub-6 100 MHz/CC, DL/UL duty cycle ~80/20, Rx: 1CC, 4 x4 MIMO, -50dBm, 256QAM, RB=273, MCS=27; Tx: 20dBm SISO, QPSK; LTE: DL 1CC, 4 x4 MIMO,20 MHz/CC, 256 QAM, RB=100, MCS=27; Tx: 20dBm SISO QPSK.	23	1A+N78	1380	1610	mA

Mode	Configuration	Tx Power (dBm)	Bands	25°C	70°C	Unit
Sub-6 1CC + LTE 2CC	DL 2400 Mbps/UL 200Mbps. Sub-6 100 MHz/CC, DL/UL duty cycle ~80/20, Rx: 1CC, 4 x4 MIMO, -50dBm, 256QAM, RB=273, MCS=27; Tx: -3dBm SISO, 256QAM1; LTE: DL 2CC, 4 x4 MIMO, 20 MHz/CC, 256 QAM, RB=100, MCS=27; Tx: -3dBm SISO 256QAM.	0	1A+3A+N78	965	1190	mA
	DL 2400 Mbps/UL 1 Mbps. Sub-6 100 MHz/CC, DL/UL duty cycle ~80/20, Rx: 1CC, 4 x4 MIMO, -50dBm, 256QAM, RB=273, MCS=27; Tx: 20dBm SISO, QPSK; LTE: DL 2CC, 4 x4 MIMO, 20 MHz/CC, 256 QAM, RB=100, MCS=27; Tx: 20dBm SISO QPSK.	23	1A+3A+N78	1490	1740	mA
Sub-6 1CC + LTE 3CC	DL 2800 Mbps/UL 200Mbps. Sub-6 100 MHz/CC, DL/UL duty cycle ~80/20, Rx: 1CC, 4 x4 MIMO, -50dBm, 256QAM, RB=273, MCS=27; Tx: -3dBm SISO, 256QAM1; LTE: DL 3CC, 4 x4 MIMO, 20 MHz/CC, 256 QAM, RB=100, MCS=27; Tx: -3dBm SISO 256QAM.	0	1A+3A+7A+N78	1090	1270	mA
	DL 2800 Mbps/UL 1 Mbps. Sub-6 100 MHz/CC, DL/UL duty cycle ~80/20, Rx: 1CC, 4 x4 MIMO, -50dBm, 256QAM, RB=273, MCS=27; Tx: 20dBm SISO, QPSK; LTE: DL 3CC, 4 x4 MIMO, 20 MHz/CC, 256 QAM, RB=100, MCS=27; Tx: 20dBm SISO QPSK.	23	1A+3A+7A+N78	1660	1950	mA
Sub-6 1CC + LTE 4CC	DL 3200 Mbps/UL 200Mbps. Sub-6 100 MHz/CC, DL/UL duty cycle ~80/20, Rx: 1CC, 4 x4 MIMO, -50dBm, 256QAM, RB=273, MCS=27; Tx: -3dBm SISO, 256QAM1; LTE: DL 4CC, 4 x4 MIMO, 20 MHz/CC, 256 QAM, RB=100, MCS=27; Tx: -3dBm, 256QAM.	0	1A+3A+7C+N78	1220	1450	mA
	DL 3200 Mbps/UL 1 Mbps. Sub-6 100 MHz/CC, DL/UL duty cycle ~80/20, Rx: 1CC, 4 x4 MIMO, -50dBm, 256QAM, RB=273, MCS=27; Tx: 20dBm SISO, QPSK; LTE: DL 4CC, 4 x4 MIMO, 20 MHz/CC, 256 QAM, RB=100, MCS=27; Tx: 20dBm SISO QPSK.	23	1A+3A+7C+N78	1780	2150	mA
Sub-6 1CC + LTE 5CC	DL 3600 Mbps/200Mbps. Sub-6 100 MHz/CC, DL/UL duty cycle ~80/20, Rx: 1CC, 4 x4 MIMO, -50dBm, 256QAM, RB=273, MCS=27; Tx: -3dBm SISO, 256QAM1; LTE: DL 5CC, 4 x4 MIMO, 20 MHz/CC, 256 QAM, RB=100, MCS=27; Tx: -3dBm, 256QAM.	0	1A+3C+7C+N78	1360	1520	mA
	DL 3600 Mbps/UL 1 Mbps. Sub-6 100 MHz/CC, DL/UL duty cycle ~80/20, Rx: 1CC, 4 x4 MIMO, -50dBm, 256QAM, RB=273, MCS=27; Tx: 20dBm SISO, QPSK; LTE: DL 5CC, 4 x4 MIMO, 20 MHz/CC, 256 QAM, RB=100, MCS=27; Tx: 20dBm SISO QPSK.	23	1A+3C+7C+N78	2030	2280	mA

## 5.5 GNSS Current

Table 5. Averaged Current, GNSS, Input Voltage 3.3V

Mode	Configuration	-40°C	25°C	85°C	Units
GNSS Acquisition	GPS Acquisition, cold start, Airplane, with USB connection	76	81	125	mA
GNSS Tracking	GPS Tracking, Airplane, with USB Connection	75	74	130	mA

## 6 References

Reference	Title
2174257	AirPrime EM9190 Thermal Application Note - Rev2.0

## 7 Support

For direct clients: contact your Sierra Wireless FAE

For distributor clients: contact your distributor FAE

For distributors: contact your Sierra Wireless FAE

## 8 Document History

Version	Date	History
1.0	July 15, 2020	Creation
1.1	September 4, 2020	Added EM9191 and EM7690 information, added details of standby current (sleep and non-sleep modes), updated 0dBm data for Sub-6 1CC + LTE 5CC in table 4.

## 9 Legal Notice

### Important Notice

Due to the nature of wireless communications, transmission and reception of data can never be guaranteed. Data may be delayed, corrupted (i.e., have errors) or be totally lost. Although significant delays or losses of data are rare when wireless devices such as the Sierra Wireless modem are used in a normal manner with a well-constructed network, the Sierra Wireless modem should not be used in situations where failure to transmit or receive data could result in damage of any kind to the user or any other party, including but not limited to personal injury, death, or loss of property. Sierra Wireless accepts no responsibility for damages of any kind resulting from delays or errors in data transmitted or received using the Sierra Wireless modem, or for failure of the Sierra Wireless modem to transmit or receive such data.

### Safety and Hazards

Do not operate the Sierra Wireless modem in areas where cellular modems are not advised without proper device certifications. These areas include environments where cellular radio can interfere such as explosive atmospheres, medical equipment, or any other equipment which may be susceptible to any form of radio interference. The Sierra Wireless modem can transmit signals that could interfere with this equipment. Do not operate the Sierra Wireless modem in any aircraft, whether the aircraft is on the ground or in flight. In aircraft, the Sierra Wireless modem **MUST BE POWERED OFF**. When operating, the Sierra Wireless modem can transmit signals that could interfere with various onboard systems.

*Note: Some airlines may permit the use of cellular phones while the aircraft is on the ground and the door is open. Sierra Wireless modems may be used at this time.*

The driver or operator of any vehicle should not operate the Sierra Wireless modem while in control of a vehicle. Doing so will detract from the driver or operator's control and operation of that vehicle. In some states and provinces, operating such communications devices while in control of a vehicle is an offence.

### Limitations of Liability

This manual is provided "as is". Sierra Wireless makes no warranties of any kind, either expressed or implied, including any implied warranties of merchantability, fitness for a particular purpose, or noninfringement. The recipient of the manual shall endorse all risks arising from its use.

The information in this manual is subject to change without notice and does not represent a commitment on the part of Sierra Wireless. SIERRA WIRELESS AND ITS AFFILIATES SPECIFICALLY DISCLAIM LIABILITY FOR ANY AND ALL DIRECT, INDIRECT, SPECIAL, GENERAL, INCIDENTAL, CONSEQUENTIAL, PUNITIVE OR EXEMPLARY DAMAGES INCLUDING, BUT NOT LIMITED TO, LOSS OF PROFITS OR REVENUE OR ANTICIPATED PROFITS OR REVENUE ARISING OUT OF THE USE OR INABILITY TO USE ANY SIERRA WIRELESS PRODUCT, EVEN IF SIERRA WIRELESS AND/OR ITS AFFILIATES HAS BEEN ADVISED OF THE POSSIBILITY OF SUCH DAMAGES OR THEY ARE FORESEEABLE OR FOR CLAIMS BY ANY THIRD PARTY.

Notwithstanding the foregoing, in no event shall Sierra Wireless and/or its affiliates aggregate liability arising under or in connection with the Sierra Wireless product, regardless of the number of events, occurrences, or claims giving rise to liability, be in excess of the price paid by the purchaser for the Sierra Wireless product.

### Patents

This product may contain technology developed by or for Sierra Wireless Inc.

This product includes technology licensed from QUALCOMM®.

This product is manufactured or sold by Sierra Wireless Inc. or its affiliates under one or more patents licensed from InterDigital Group and MMP Portfolio Licensing.

### Copyright

© 2016 Sierra Wireless. All rights reserved.



**Trademarks**

Sierra Wireless®, AirPrime®, AirLink®, AirVantage®, WISMO®, ALEOS® and the Sierra Wireless and Open AT logos are registered trademarks of Sierra Wireless, Inc. or one of its subsidiaries.

Watcher® is a registered trademark of Netgear, Inc., used under license.

Windows® and Windows Vista® are registered trademarks of Microsoft Corporation.

Macintosh® and Mac OS X® are registered trademarks of Apple Inc., registered in the U.S. and other countries.

QUALCOMM® is a registered trademark of QUALCOMM Incorporated. Used under license.

Other trademarks are the property of their respective owners.