



# AirPrime XA12xx and XM1210

## Software User Guide



**SIERRA**  
WIRELESS®

41112896  
Rev 5.0

## Important Notice

Due to the nature of wireless communications, transmission and reception of data can never be guaranteed. Data may be delayed, corrupted (i.e., have errors) or be totally lost. Although significant delays or losses of data are rare when wireless devices such as the Sierra Wireless product are used in a normal manner with a well-constructed network, the Sierra Wireless product should not be used in situations where failure to transmit or receive data could result in damage of any kind to the user or any other party, including but not limited to personal injury, death, or loss of property. Sierra Wireless accepts no responsibility for damages of any kind resulting from delays or errors in data transmitted or received using the Sierra Wireless product, or for failure of the Sierra Wireless product to transmit or receive such data.

## Safety and Hazards

Do not operate the Sierra Wireless product in areas where blasting is in progress, where explosive atmospheres may be present, near medical equipment, near life support equipment, or any equipment which may be susceptible to any form of radio interference. In such areas, the Sierra Wireless product **MUST BE POWERED OFF**. The Sierra Wireless product can transmit signals that could interfere with this equipment.

Do not operate the Sierra Wireless product in any aircraft, whether the aircraft is on the ground or in flight. In aircraft, the Sierra Wireless product **MUST BE POWERED OFF**. When operating, the Sierra Wireless product can transmit signals that could interfere with various onboard systems.

---

*Note: Some airlines may permit the use of cellular phones while the aircraft is on the ground and the door is open. Sierra Wireless products may be used at this time.*

---

The driver or operator of any vehicle should not operate the Sierra Wireless product while in control of a vehicle. Doing so will detract from the driver or operator's control and operation of that vehicle. In some states and provinces, operating such communications devices while in control of a vehicle is an offence.

## Limitation of Liability

The information in this manual is subject to change without notice and does not represent a commitment on the part of Sierra Wireless. SIERRA WIRELESS AND ITS AFFILIATES SPECIFICALLY DISCLAIM LIABILITY FOR ANY AND ALL DIRECT, INDIRECT, SPECIAL, GENERAL, INCIDENTAL, CONSEQUENTIAL, PUNITIVE OR EXEMPLARY DAMAGES INCLUDING, BUT NOT LIMITED TO, LOSS OF PROFITS OR REVENUE OR ANTICIPATED PROFITS OR REVENUE ARISING OUT OF THE USE OR INABILITY TO USE ANY SIERRA WIRELESS PRODUCT, EVEN IF SIERRA WIRELESS AND/OR ITS AFFILIATES HAS BEEN ADVISED OF THE POSSIBILITY OF SUCH DAMAGES OR THEY ARE FORESEEABLE OR FOR CLAIMS BY ANY THIRD PARTY.

Notwithstanding the foregoing, in no event shall Sierra Wireless and/or its affiliates aggregate liability arising under or in connection with the Sierra Wireless product, regardless of the number of events, occurrences, or claims giving rise to liability, be in excess of the price paid by the purchaser for the Sierra Wireless product.

## Patents

This product may contain technology developed by or for Sierra Wireless Inc. This product is manufactured or sold by Sierra Wireless Inc. or its affiliates under one or more patents licensed from MMP Portfolio Licensing.

## Copyright

© 2020 Sierra Wireless. All rights reserved.

## Trademarks

Sierra Wireless<sup>®</sup>, AirPrime<sup>®</sup>, AirLink<sup>®</sup>, AirVantage<sup>®</sup> and the Sierra Wireless logo are registered trademarks of Sierra Wireless.

Windows<sup>®</sup> and Windows Vista<sup>®</sup> are registered trademarks of Microsoft Corporation.

Other trademarks are the property of their respective owners.

## Contact Information

Sales information and technical support, including warranty and returns	Web: <a href="http://sierrawireless.com/company/contact-us/">sierrawireless.com/company/contact-us/</a> Global toll-free number: 1-877-687-7795 6:00 am to 5:00 pm PST
Corporate and product information	Web: <a href="http://sierrawireless.com">sierrawireless.com</a>

## Revision History

Revision number	Release date	Changes
1.0	November 02, 2018	Creation
2.0	February 21, 2019	Added: <ul style="list-style-type: none"> <li>• GPS + Galileo in <a href="#">CFG-NAVSAT GNSS Search Mode Setting</a> on page 9 and <a href="#">CFG-NAVSAT Query GNSS Search Mode</a> on page 10</li> <li>• <a href="#">CFG-EPHSAVE Ephemeris Runtime Flash Saving Setting</a> on page 33</li> <li>• <a href="#">CFG-EPHSAVE Query Ephemeris Runtime Flash Saving Status</a> on page 34</li> <li>• <a href="#">CFG-MSG Setting NMEA Output Rate</a> on page 36</li> <li>• <a href="#">CFG-MSG Query NMEA Output Rate</a> on page 37</li> <li>• <a href="#">CFG-CFG Save and Clear Current Configuration</a> on page 39</li> </ul> Updated <a href="#">CFG-PRT Baud Rate Setting</a> on page 14
2.1	March 11, 2019	Updated <a href="#">CFG-EPHSAVE Query Ephemeris Runtime Flash Saving Status</a> on page 34
3.0	May 14, 2019	Updated <a href="#">CFG-SLEEP Power Save Mode Setting</a> on page 21
4.0	July 29, 2019	Updated <a href="#">MON-INFO Query Firmware Version</a> on page 22
5.0	August 4, 2020	Updated <a href="#">CFG-NAVSAT GNSS Search Mode Setting</a> tables

# >> Contents

<b>Command Format</b> .....	<b>5</b>
Command Fields .....	5
Data Type .....	6
SBAS Description .....	6
<b>Command Types</b> .....	<b>8</b>
Boot Message .....	8
Command Response .....	8
CFG-NAVSAT GNSS Search Mode Setting .....	9
CFG-NAVSAT Query GNSS Search Mode .....	10
CFG-NMEAYER GNSS NMEA Version Setting .....	12
CFG-NMEAYER Query GNSS NMEA Version .....	13
CFG-PRT Baud Rate Setting .....	14
CFG-SBAS GNSS SBAS System Setting .....	15
CFG-SBAS Query GNSS SBAS System .....	17
CFG-SIMPLERST Module Startup .....	20
CFG-SLEEP Power Save Mode Setting .....	21
MON-INFO Query Firmware Version .....	22
MON-INFOADD Query Serial Number .....	23
CFG-PVTLOG PVT Log in Flash Setting .....	24
CFG-PVTLOG Query PVT Log in Flash .....	25
CFG-ANTIJAM GNSS Anti-Jamming Mode Setting .....	27
CFG-ANTIJAM GNSS Anti-Jamming Detection .....	28
CFG-ANTIJAM Query GNSS Anti-Jamming Mode .....	29
CFG-PPS 1PPS Delay Compensation Setting .....	30
CFG-PPS Query 1PPS Delay Compensation .....	32
CFG-EPHSAVE Ephemeris Runtime Flash Saving Setting .....	33
CFG-EPHSAVE Query Ephemeris Runtime Flash Saving Status .....	34
CFG-MSG Setting NMEA Output Rate .....	36
CFG-MSG Query NMEA Output Rate .....	37
CFG-CFG Save and Clear Current Configuration .....	39

# >> 1: Command Format

## Command Fields

XA12xx and XM1210 command formats are defined in the table below.

**Table 1-1: Command Formats**

Field	Format	Definition
Start	\$PHD	Start sequence
Class ID	CC	Class ID
Message ID	MM	Message ID
Payload length	[m]*	Payload length
Return	[r]*	Return payload length
Payload	[field]*	Parameters
Delimiter	*	Boundary symbol
Checksum	SS	Checksum
End	<CR><LF>	End

A poll UART configuration information command (CFG-PRT) is given as an example below.

**Table 1-2: Poll UART Configuration Message and Response**

Field	Format	Send Command	Response
Start	\$PHD	\$PHD	\$PHD
Class ID	CC	06	06
Message ID	MM	00	00
Payload length	[m]*	U	UUUUT
Return	[r]*	UUUUT	NULL
Payload	[field]*	NULL	0,44,48,49,115200
Delimiter	*	*	*
Checksum	SS	47	14
End	<CR><LF>	<CR><LF>	<CR><LF>

## Data Type

**Table 1-3: Data Type Definition**

Data Type	Symbol	Definition	Length (Byte)
Decimal	C	Signed char	1
	U	Unsigned char	1
	M	Signed short	2
	N	Unsigned short	2
	I	Signed int	4
	T	Unsigned int	4
Float	F	Float	4
	D	Double	8
Hex	B	Hex	1
	H	Hex	2
	X	Hex	4
String	A	Short string	16
	Z	Long string	32

## SBAS Description

There are several compatible SBAS systems available or in development:

- WAAS (Wide Area Augmentation System) for North America has been in operation since 2003,
- MSAS (Multi-Functional Satellite Augmentation System) for Asia has been in operation since 2007,
- EGNOS (European Geostationary Navigation Overlay Service) has been in operation since 2009,
- GAGAN (GPS Aided Geo Augmented Navigation), and
- SDCM (Difference correction and monitoring system).

The following table shows the SBAS PRN value in HD NMEA protocol.

**Table 1-4: SBAS PRN Values in HD NMEA Protocol**

NMEA Version	WAAS		EGNOS		GAGAN		MSAS		SDCM	
	Original PRN	HD PRN	Original PRN	HD PRN	Original PRN	HD PRN	Original PRN	HD PRN	Original PRN	HD PRN
3.01	135	48	120	33	127	40	129	42	140	53
	138	51	124	37	128	41	137	50	125	38
	133	46	126	39	-	-	-	-	-	-
	-	-	136	49	-	-	-	-	-	-
4.00	135	135	120	120	127	127	129	129	140	140
	138	138	124	124	128	128	137	137	125	125
	133	133	126	126	-	-	-	-	-	-
	-	-	136	136	-	-	-	-	-	-
4.10	135	48	120	33	127	40	129	42	140	53
	138	51	124	37	128	41	137	50	125	38
	133	46	126	39	-	-	-	-	-	-
	-	-	136	49	-	-	-	-	-	-

*Note: In NMEA v3.01 and v4.10, the SBAS PRN offset value is set with -87; while in v4.00, the SBAS PRN offset value is set with 0.*

## >> 2: Command Types

### Boot Message

Command Definition: System startup status output message

Send Command Data Field Message Structure:

Start	Payload Parameter				Checksum	End
\$GNTXT	U	U	U	A	CK_1 CK_2	<CR><LF>

Payload Parameter:

Byte Offset	Description
U	Total number in the current period
U	Subsequent ID counting from 01, 02 and so on
U	System first starting message
A	ALLYSTAR or ANT_OK flag

Examples:

\$GNTXT, 02, 01, 01, ALLYSTAR\*43<CR><LF> (after hardware reset)

\$GNTXT, 02, 01, 02, ALLYSTAR\*37<CR><LF> (after reset by start command)

\$GNTXT, 02, 02, 02, ANT\_OK\*53<CR><LF> (antenna connected)

### Command Response

Command Definition: Response status of the command executed

Response Data Field Message Structure:

Start	Class ID	Message ID	Send Payload Length	Return Payload Length	Payload Parameter	Checksum	End
\$PHD	05	01 (Success) 00 (Fail)	BB	NULL	See table below	CK_1 CK_2	<CR><LF>

Payload Parameter (total 2 bytes):

Byte Offset	Name	Description
0-1	Class ID	Command Class ID
1-2	Msg ID	Command Message ID

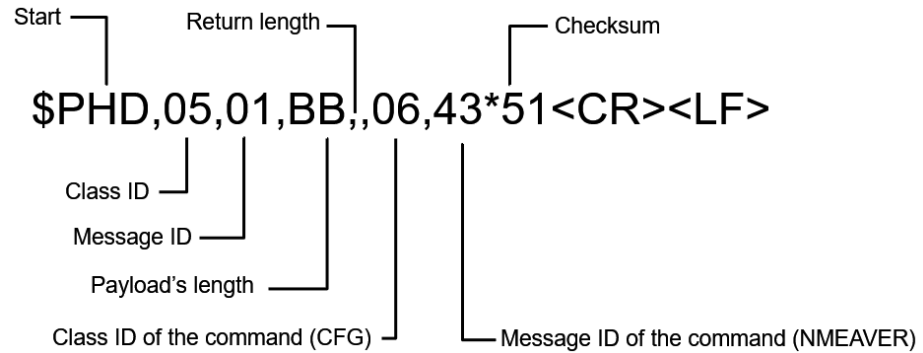

Figure 2-1: Command Ack NMEA Setting (CFG-NMEAYER) Example

Example:

Command	Response
Configure GPS+GLONASS (correct command) \$PHD,06,0C,T,BB,99*51<CR><LF>	Response when setting is successful: \$PHD,05,01,BB,,06,0C*2D<CR><LF>
Configure NMEA (wrong command) \$PHD,06,43,U,BB,1*15<CR><LF>	Response when setting fails: \$PHD,05,00,BB,,06,43*2D<CR><LF>

## CFG-NAVSAT GNSS Search Mode Setting

Command Definition: Configure GNSS search mode

Send Command Data Field Message Structure:

(Refer to [Table 1-1](#) on page 5 and [Table 1-3](#) on page 6 for details.)

Start	Class ID	Message ID	Send Payload Length	Return Payload Length	Payload Parameter	Checksum	End
\$PHD	06	0C	T	BB	See table below	CK_1 CK_2	<CR><LF>

Payload Parameter (total 4 bytes):

Byte Offset	Name	Description
0-4	Enable Mask	97: GPS 99: GPS+GLONASS 101: GPS+BeiDou 113: GPS+Galileo 115: GPS+Galileo+GLONASS 117: GPS+Galileo+BeiDou

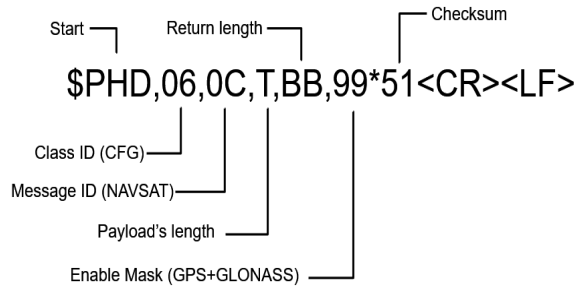

Figure 2-2: Set GNSS Search Mode Example

Response Sentence Field (refer to [Figure 2-1](#) on page 9 for details):

\$PHD,05,01,BB,,06,0C\*2D<CR><LF>

Example:

Command	Response
GPS+GLONASS \$PHD,06,0C,T,BB,99*51<CR><LF>	\$PHD,05,01,BB,,06,0C*2D<CR><LF>
GPS+BeiDou \$PHD,06,0C,T,BB,101*57<CR><LF>	\$PHD,05,01,BB,,06,0C*2D<CR><LF>

Note: All supported modes are included in SBAS and QZSS.

## CFG-NAVSAT Query GNSS Search Mode

Command Definition: Query GNSS search mode

Send Command Data Field Message Structure:

(Refer to [Table 1-1](#) on page 5 and [Table 1-3](#) on page 6 for details.)

Start	Class ID	Message ID	Send Payload Length	Return Payload Length	Payload Parameter	Checksum	End
\$PHD	06	0C	NULL	T	None	CK_1 CK_2	<CR><LF>

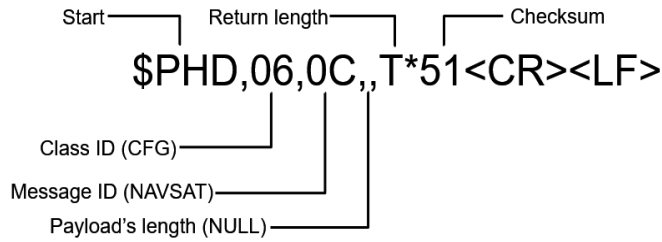

Figure 2-3: Query GNSS Search Mode Example

Response Sentence Field Message Structure:

(Refer to [Table 1-1](#) on page 5 and [Table 1-3](#) on page 6 for details.)

Start	Class ID	Message ID	Send Payload Length	Return Payload Length	Payload Parameter	Checksum	End
\$PHD	06	0C	T	NULL	See table below	CK_1 CK_2	<CR><LF>

Payload Parameter (total 4 bytes):

Byte Offset	Name	Description
0-4	Enable Mask	97: GPS 99: GPS+GLONASS 101: GPS+BeiDou 113: GPS+Galileo 115: GPS+Galileo+GLONASS 117: GPS+Galileo+BeiDou

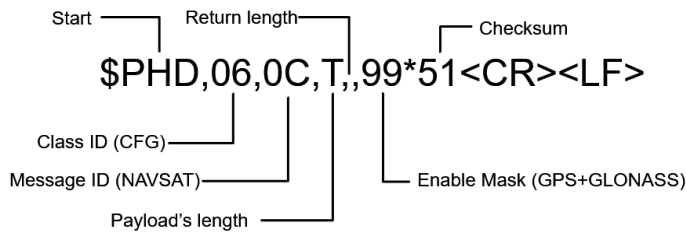

Figure 2-4: Query GNSS Search Mode Response Example

Example:

Command	Response
Query GNSS search mode: \$PHD,06,0C,,T*7D<CR><LF>	Get GNSS search mode: GPS+GLONASS \$PHD,06,0C,T,,99*51<CR><LF> GPS+Beidou \$PHD,06,0C,T,,101*61<CR><LF>

Note: All supported modes are included in SBAS and QZSS.

## CFG-NMEAYER GNSS NMEA Version Setting

Command Definition: Configure GNSS NMEA version

Send Command Data Field Message Structure:

(Refer to [Table 1-1](#) on page 5 and [Table 1-3](#) on page 6 for details.)

Start	Class ID	Message ID	Send Payload Length	Return Payload Length	Payload Parameter	Checksum	End
\$PHD	06	43	U	BB	See table below	CK_1 CK_2	<CR><LF>

Payload Parameter (total 1 byte):

Byte Offset	Name	Description
0-1	NMEA version	1: NMEA v3.01 2: NMEA v4.00 3: NMEA v4.10

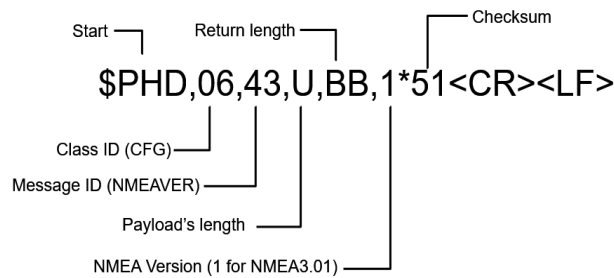

Figure 2-5: Configure GNSS NMEA Version Example

Response Sentence Field (refer to [Figure 2-1](#) on page 9 for details):

`$PHD,05,01,BB,,06,43*59<CR><LF>`

Example:

Command	Response
Configure NMEA3.01 \$PHD,06,43,U,BB,1*15<CR><LF> Configure NMEA4.00 \$PHD,06,43,U,BB,2*16<CR><LF> Configure NMEA4.10 \$PHD,06,43,U,BB,3*17<CR><LF>	\$PHD,05,01,BB,,06,43*59<CR><LF>

## CFG-NMEAYER Query GNSS NMEA Version

Command Definition: Query GNSS NMEA version

Send Command Data Field Message Structure:

(Refer to [Table 1-1](#) on page 5 and [Table 1-3](#) on page 6 for details.)

Start	Class ID	Message ID	Send Payload Length	Return Payload Length	Payload Parameter	Checksum	End
\$PHD	06	43	NULL	U	None	CK_1 CK_2	<CR><LF>

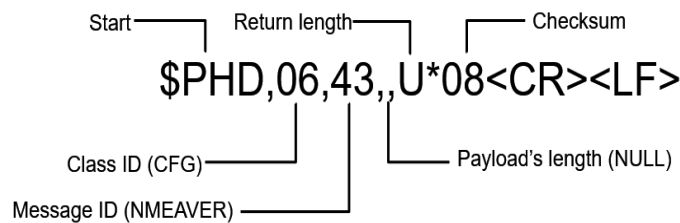

Figure 2-6: Query GNSS NMEA Version Example

Response Sentence Field Message Structure:

(Refer to [Table 1-1](#) on page 5 and [Table 1-3](#) on page 6 for details.)

Start	Class ID	Message ID	Send Payload Length	Return Payload Length	Payload Parameter	Checksum	End
\$PHD	06	43	U	NULL	See table below	CK_1 CK_2	<CR><LF>

Payload Parameter (total 1 byte):

Byte Offset	Name	Description
0-1	NMEA Version	1: NMEA v3.01 2: NMEA v4.00 3: NMEA v4.10

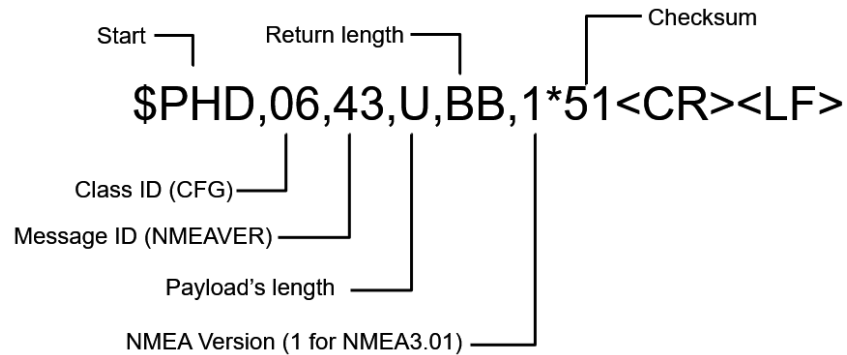

Figure 2-7: Query GNSS NMEA Version Response Example

Example:

Command	Response
Query NMEA version: <code>\$PHD,06,43,,U*08&lt;CR&gt;&lt;LF&gt;</code>	Setting is NMEA3.01: <code>\$PHD,06,43,U,,1*15&lt;CR&gt;&lt;LF&gt;</code> Setting is NMEA4.00: <code>\$PHD,06,43,U,,2*16&lt;CR&gt;&lt;LF&gt;</code> Setting is NMEA4.10: <code>\$PHD,06,43,U,,3*17&lt;CR&gt;&lt;LF&gt;</code>

## CFG-PRT Baud Rate Setting

Command Definition: Configure GNSS UART0 baud rate

Send Command Data Field Message Structure:

(Refer to [Table 1-1](#) on page 5 and [Table 1-3](#) on page 6 for details.)

Start	Class ID	Message ID	Send Payload Length	Return Payload Length	Payload Parameter	Checksum	End
\$PHD	06	00	UUUUT	BB	See table below	CK_1 CK_2	<CR><LF>

Payload Parameter (total 8 bytes):

Byte Offset	Name	Description
0-1	Port ID	0: UART0
1-4	res	Reserved
4-8	Baud Rate	9600/19200/38400/57600/115200

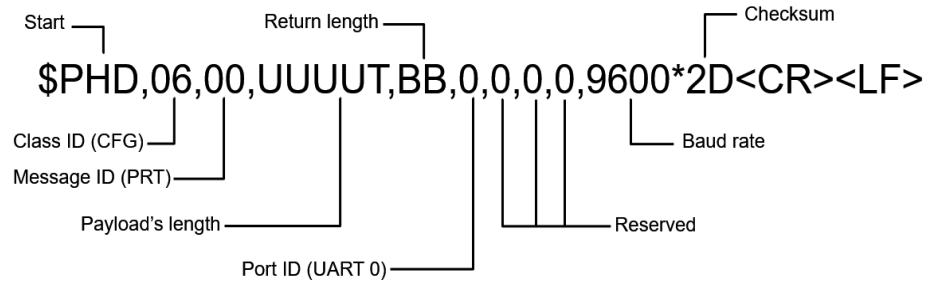

Figure 2-8: Set Baud Rate Example

Response Sentence Field: No feedback since the baud rate has changed. Change the serial port to check.

Example:

Command	Response
Set UART0 to baud rate 9600 \$PHD,06,00,UUUUT,BB,0,0,0,0,9600*2D<CR><LF>	None

## CFG-SBAS GNSS SBAS System Setting

Command Definition: Configure GNSS SBAS system. Refer to [Table 1-4](#) on page 7 for details regarding SBAS.

Send Command Data Field Message Structure:

(Refer to [Table 1-1](#) on page 5 and [Table 1-3](#) on page 6 for details.)

Start	Class ID	Message ID	Send Payload Length	Return Payload Length	Payload Parameter	Checksum	End
\$PHD	06	0E	UUUUU UUUUU UUUUU UUUUU (total of 20 Us)	BB	See table below	CK_1 CK_2	<CR><LF>

## Payload Parameter 1 (total 20 bytes):

Byte Offset	Name	Description
0-1	MTSAT2	137
1-2	flag	0: Disable 1: Enable
2-3	GSAT8	127
3-4	flag	0: Disable 1: Enable
4-5	GSAT10	128
5-6	flag	0: Disable 1: Enable
6-7	INMARSAT3F2	120
7-8	flag	0: Disable 1: Enable
8-9	ASTRA5B	123
9-10	flag	0: Disable 1: Enable

## Payload Parameter 2 (total 20 bytes):

Byte Offset	Name	Description
10-11	GALAXY15	135
11-12	flag	0: Disable 1: Enable
12-13	ANIKF1R	138
13-14	flag	0: Disable 1: Enable
14-15	LUCH5A	140
15-16	flag	0: Disable 1: Enable
16-17	LUCH5B	125
17-18	flag	0: Disable 1: Enable
18-19	LUCH5V	141
19-20	flag	0: Disable 1: Enable

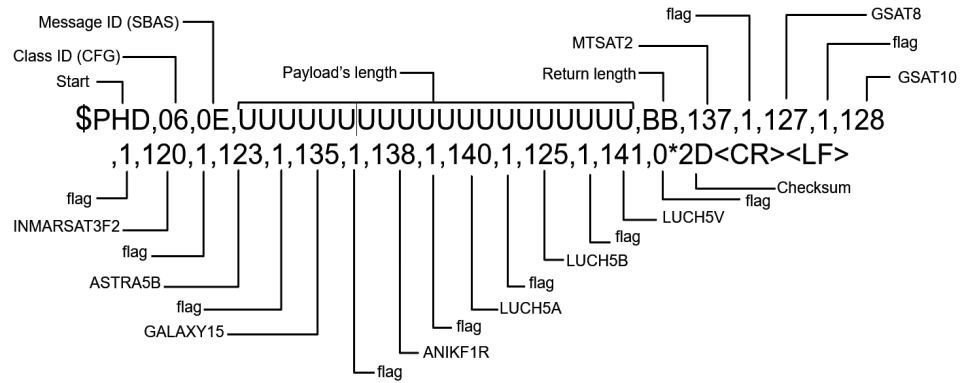

Figure 2-9: Disable LUCH5V Example

Response Sentence Field (refer to [Figure 2-1](#) on page 9 for details):

\$PHD, 05, 01, BB, , 06, 0E\*2B<CR><LF>

Example:

Command	Response
Configure disable LUCH5V \$PHD, 06, 0E, UUUUUUUUUUUUUUUUUUUUU, BB, 137, 1, 127, 1, 128, 1, 120, 1, 123, 1, 135, 1, 138, 1, 140, 1, 125, 1, 141, 0*2D<CR><LF>	\$PHD, 05, 01, BB, , 06, 0E*2B

## CFG-SBAS Query GNSS SBAS System

Command Definition: Query GNSS SBAS system

Send Command Data Field Message Structure:

(Refer to [Table 1-1](#) on page 5 and [Table 1-3](#) on page 6 for details.)

Start	Class ID	Message ID	Send Payload Length	Return Payload Length	Payload Parameter	Checksum	End
\$PHD	06	0E	NULL	UUUUU UUUUU UUUUU UUUUU (total of 20 Us)	None	CK_1 CK_2	<CR><LF>

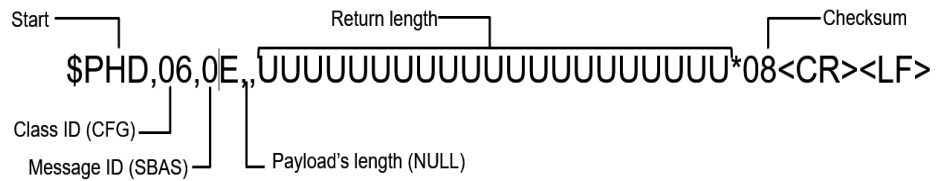

Figure 2-10: Query GNSS SBAS System Example

Response Sentence Field Message Structure:

(Refer to [Table 1-1](#) on page 5 and [Table 1-3](#) on page 6 for details.)

Start	Class ID	Message ID	Send Payload Length	Return Payload Length	Payload Parameter	Checksum	End
\$PHD	06	0E	UUUUU UUUUU UUUUU (total of 20 Us)	NULL	See table below	CK_1 CK_2	<CR><LF>

Payload Parameter 1 (total 20 bytes):

Byte Offset	Name	Description
0-1	MTSAT2	137
1-2	flag	0: Disable 1: Enable
2-3	GSAT8	127
3-4	flag	0: Disable 1: Enable
4-5	GSAT10	128
5-6	flag	0: Disable 1: Enable
6-7	INMARSAT3F2	120
7-8	flag	0: Disable 1: Enable
8-9	ASTRA5B	123
9-10	flag	0: Disable 1: Enable

Payload Parameter 2 (total 20 bytes):

Byte Offset	Name	Description
10-11	GALAXY15	135
11-12	flag	0: Disable 1: Enable
12-13	ANIKF1R	138
13-14	flag	0: Disable 1: Enable
14-15	LUCH5A	140
15-16	flag	0: Disable 1: Enable
16-17	LUCH5B	125
17-18	flag	0: Disable 1: Enable
18-19	LUCH5V	141
19-20	flag	0: Disable 1: Enable

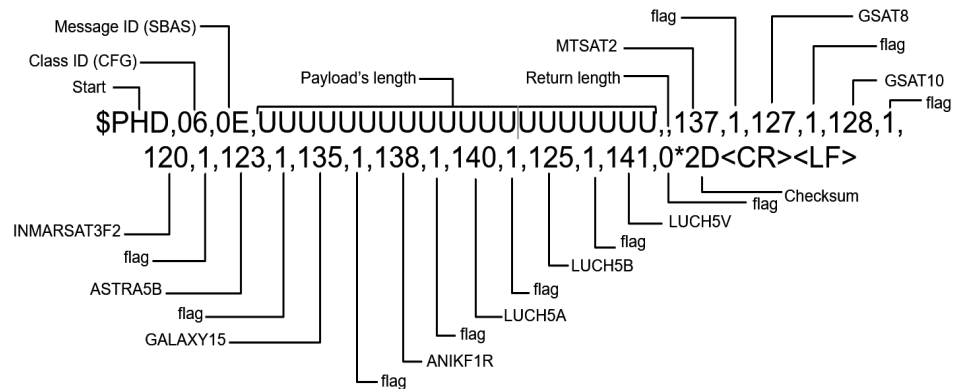

Figure 2-11: Query GNSS SBAS System Response Example



Example:

Command	Response
Reset \$PHD,06,40,U,BB,0*17<CR><LF>	System reset
Cold Start \$PHD,06,40,U,BB,1*16<CR><LF>	
Warm Start \$PHD,06,40,U,BB,2*15<CR><LF>	
Hot Start \$PHD,06,40,U,BB,3*14<CR><LF>	

## CFG-SLEEP Power Save Mode Setting

Command Definition: Execute GNSS power save procedure

Send Command Data Field Message Structure:

(Refer to [Table 1-1](#) on page 5 and [Table 1-3](#) on page 6 for details.)

Start	Class ID	Message ID	Send Payload Length	Return Payload Length	Payload Parameter	Checksum	End
\$PHD	06	41	TN	BB	See table below	CK_1 CK_2	<CR><LF>

Payload Parameter (total 6 bytes):

Byte Offset	Name	Description
0-4	Period (ms)	Sleep time (0-4, 294, 967, 295)
4-6	Action	0: Sleep 1: Deep sleep 3: Main power down

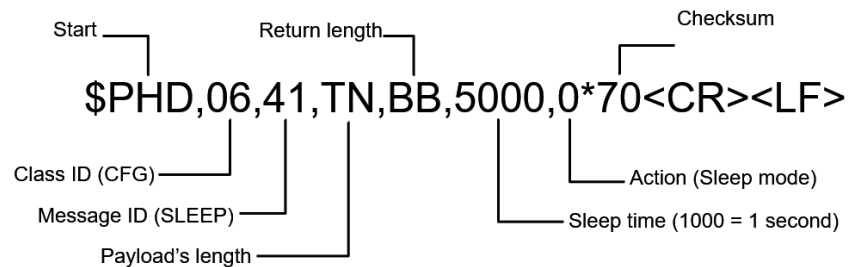

Figure 2-13: Set Power Save Mode Example

Response Sentence Field: System sleep

Example:

Command	Response
Sleep mode \$PHD,06,41,TN,BB,5000,0*70<CR><LF>	System sleep
Deep sleep mode \$PHD,06,41,TN,BB,5000,1*71<CR><LF>	
Main power down mode \$PHD,06,41,TN,BB,5000,3*73<CR><LF>	

## MON-INFO Query Firmware Version

Command Definition: Query GNSS firmware version

Send Command Data Field Message Structure:

(Refer to [Table 1-1](#) on page 5 and [Table 1-3](#) on page 6 for details.)

Start	Class ID	Message ID	Send Payload Length	Return Payload Length	Payload Parameter	Checksum	End
\$PHD	0A	05	NULL	A	None	CK_1 CK_2	<CR><LF>

Response Sentence Field Message Structure:

(Refer to [Table 1-1](#) on page 5 and [Table 1-3](#) on page 6 for details.)

Start	Class ID	Message ID	Send Payload Length	Return Payload Length	Payload Parameter	Checksum	End
\$PHD	0A	05	A	NULL	See table below	CK_1 CK_2	<CR><LF>

Payload Parameter (total 16 bytes):

Byte Offset	Name	Description
0-16	Firmware version	Firmware version

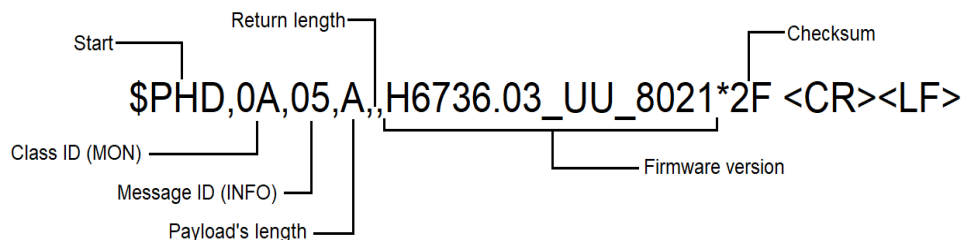

Figure 2-14: Query GNSS Firmware Example

Example:

Command	Response
\$PHD,0A,05,,A*69<CR><LF>	The firmware version field is NULL \$PHD,0A,05,A,,NULL*5E<CR><LF> The firmware version is H6736.01_UU_8021 \$PHD,0A,05,A,,H6736.03_UU_8021*2F<CR><LF>

## MON-INFOADD Query Serial Number

Command Definition: Query the module's serial number

Send Command Data Field Message Structure:

(Refer to [Table 1-1](#) on page 5 and [Table 1-3](#) on page 6 for details.)

Start	Class ID	Message ID	Send Payload Length	Return Payload Length	Payload Parameter	Checksum	End
\$PHD	0A	20	NULL	A	None	CK_1 CK_2	<CR><LF>

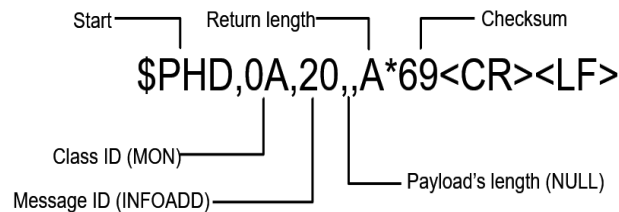

Figure 2-15: Query Serial Number Example

Response Sentence Field Message Structure:

(Refer to [Table 1-1](#) on page 5 and [Table 1-3](#) on page 6 for details.)

Start	Class ID	Message ID	Send Payload Length	Return Payload Length	Payload Parameter	Checksum	End
\$PHD	0A	20	A	NULL	See table below	CK_1 CK_2	<CR><LF>

Payload Parameter (total 16 bytes):

Byte Offset	Name	Description
0-16	Serial number	Firmware serial number

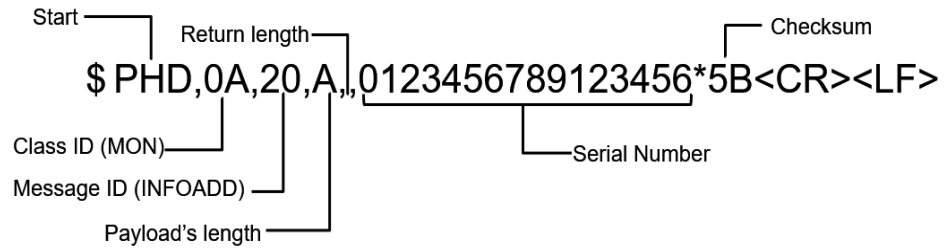

Figure 2-16: Query Serial Number Response Example

Example:

Command	Response
\$PHD,0A,20,,A*6E<CR><LF>	The serial number field is NULL \$PHD,0A,20,A,,NULL*59<CR><LF> The serial number is 0123456789123456 \$PHD,0A,20,A,,0123456789123456*5B<CR><LF>

## CFG-PVTLOG PVT Log in Flash Setting

Command Definition: Configure PVT log in flash mode

Send Command Data Field Message Structure:

(Refer to [Table 1-1](#) on page 5 and [Table 1-3](#) on page 6 for details.)

Start	Class ID	Message ID	Send Payload Length	Return Payload Length	Payload Parameter	Checksum	End
\$PHD	06	B0	UN	BB	See table below	CK_1 CK_2	<CR><LF>

Payload Parameter (total 3 bytes):

Byte Offset	Name	Description
0-1	Flash mode	0: Log writing disable 1: Log writing enable 2: Log erase
1-3	Period (second)	1-3600 (only useful when flash mode=1)

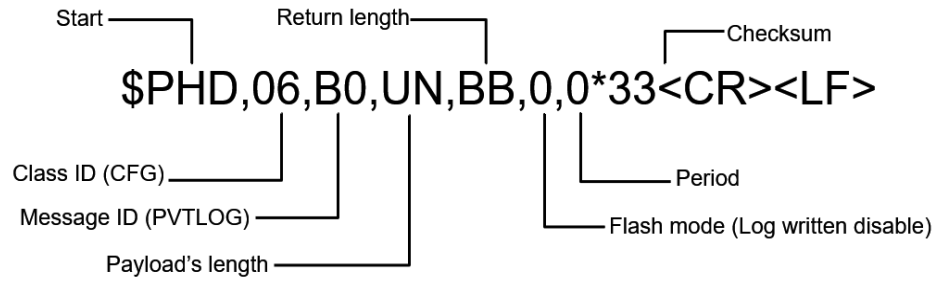

Figure 2-17: Set PVT Log in Flash Mode Example

Response Sentence Field (refer to [Figure 2-1](#) on page 9 for details):

`$PHD,05,01,BB,,06,B0*2C<CR><LF>`

Example:

Command	Response
Log written disable <code>\$PHD,06,B0,UN,BB,0,0*33&lt;CR&gt;&lt;LF&gt;</code>	<code>\$PHD,05,01,BB,,06,B0*2C&lt;CR&gt;&lt;LF&gt;</code>
Log enable written as ones per second <code>\$PHD,06,B0,UN,BB,1,1*33&lt;CR&gt;&lt;LF&gt;</code>	
Log erase <code>\$PHD,06,B0,UN,BB,2,0*31&lt;CR&gt;&lt;LF&gt;</code>	

## CFG-PVTLOG Query PVT Log in Flash

Command Definition: Configure PVT log in flash mode (can only poll the first position every period)

Send Command Data Field Message Structure:

(Refer to [Table 1-1](#) on page 5 and [Table 1-3](#) on page 6 for details.)

Start	Class ID	Message ID	Send Payload Length	Return Payload Length	Payload Parameter	Checksum	End
\$PHD	06	B0	U	NNNNTTF FFF	See table below	CK_1 CK_2	<CR><LF>

Payload Parameter (total 1 byte):

Byte Offset	Name	Description
0-1	Log sector	0-31

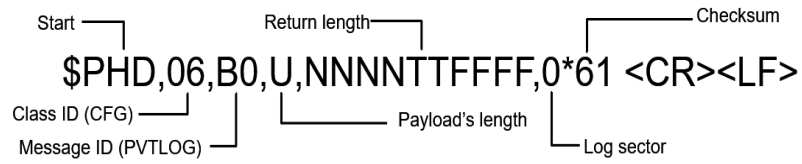

Figure 2-18: Query PVT Log in Flash Example

Response Sentence Field Message Structure:

(Refer to [Table 1-1](#) on page 5 and [Table 1-3](#) on page 6 for details.)

Start	Class ID	Message ID	Send Payload Length	Return Payload Length	Payload Parameter	Checksum	End
\$PHD	06	B0	NNNNTT FFFF	NULL	See table below	CK_1 CK_2	<CR><LF>

Payload Parameter (total 32 bytes):

Byte Offset	Name	Description
0-2	Month	UTC month
2-4	Date	UTC date
4-6	Hour	UTC hour
6-8	Minute	UTC minute
8-12	Second	UTC second (in deciseconds)
12-16	Year	UTC year
16-20	Latitude	Latitude
20-24	Longitude	Longitude
24-28	Altitude	Altitude above mean sea level
28-32	Gspd	Ground speed (2D)

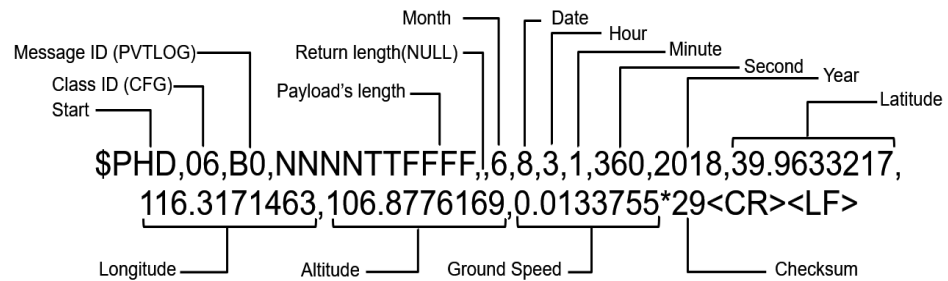

Figure 2-19: Query PVT Log in Flash Response Example

Example:

Command	Response
\$PHD,06,B0,U,NNNNTTFFFF,1*60<CR><LF>	\$PHD,06,B0,NNNNTTFFFF,,6,8,3,1,360,2018,39.9633217,116.3171463,106.8776169,0.0133755*29<CR><LF>

## CFG-ANTI JAM GNSS Anti-Jamming Mode Setting

Command Definition: Control anti-jamming satellite system and threshold. Occupies two tracking channels; the TTFF may be extended.

Send Command Data Field Message Structure:

(Refer to [Table 1-1](#) on page 5 and [Table 1-3](#) on page 6 for details.)

Start	Class ID	Message ID	Send Payload Length	Return Payload Length	Payload Parameter	Checksum	End
\$PHD	06	15	HU	BB	See table below	CK_1 CK_2	<CR><LF>

Payload Parameter (total 3 bytes):

Byte Offset	Name	Description
0-2	Satellite system mask	0002: GPS 0020: Beidou 0022: GPS+Beidou
2-3	Threshold (dB)	Power threshold that activates the anti-jamming mechanism

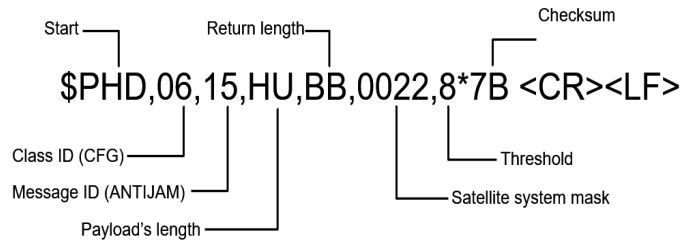

Figure 2-20: Set GNSS Anti-Jamming Mode Example

Response Sentence Field (refer to [Figure 2-1](#) on page 9 for details):

\$PHD,05,01,BB,,06,15\*5A

Example:

Command	Response
\$PHD,06,15,HU,BB,0022,8*7B <CR><LF>	\$PHD,05,01,BB,,06,15*5A <CR><LF>

## CFG-ANTIJAM GNSS Anti-Jamming Detection

Command Definition: Detect current module interferences. Satellite must be set to display \$GNJAM in NMEA. Only available in UART mode.

Send Command Data Field Message Structure:

Start	Payload Parameter				Checksum
\$GNJAM	xx	xx	xx	xx	CK_1 CK_2

Payload Parameter:

Byte Offset	Name	Description
xx	GPS power	Represents the intensity value and shows how much the interference signal is greater than the actual signal (for GPS)
xx	GPS frequency	Represents the number of deviations in Hz from the center frequency of the system (for GPS)
xx	Beidou power	Represents the intensity value and shows how much the interference signal is greater than the actual signal (for Beidou)
xx	Beidou frequency	Represents the number of deviations in Hz from the center frequency of the system (for Beidou)

Example: \$GNJAM,1,-168500,,\*59<CR><LF>

## CFG-ANTIJAM Query GNSS Anti-Jamming Mode

Command Definition: Query anti-jamming settings

Send Command Data Field Message Structure:

(Refer to [Table 1-1](#) on page 5 and [Table 1-3](#) on page 6 for details.)

Start	Class ID	Message ID	Send Payload Length	Return Payload Length	Payload Parameter	Checksum	End
\$PHD	06	15	NULL	HU	None	CK_1 CK_2	<CR><LF>

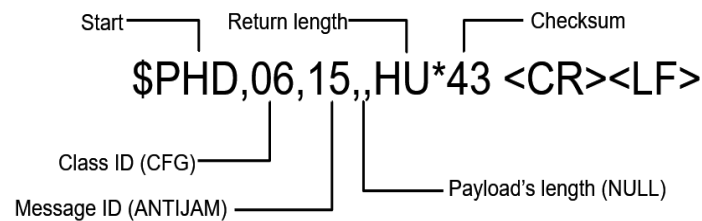

Figure 2-21: Query GNSS Anti-Jamming Mode Example

Response Sentence Field Message Structure:

(Refer to [Table 1-1](#) on page 5 and [Table 1-3](#) on page 6 for details.)

Start	Class ID	Message ID	Send Payload Length	Return Payload Length	Payload Parameter	Checksum	End
\$PHD	06	15	HU	NULL	See table below	CK_1 CK_2	<CR><LF>

Payload Parameter (total 3 bytes):

Byte Offset	Name	Description
0-2	Satellite system mask	0002: GPS 0020: Beidou 0022: GPS+Beidou
2-3	Threshold (dB)	Power threshold that activates the anti-jamming mechanism

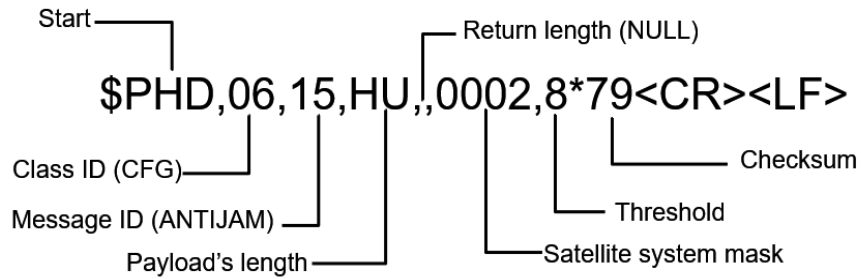

Figure 2-22: Query GNSS Anti-Jamming Mode Response Example

Example:

Command	Response
\$PHD,06,15,,HU*43 <CR><LF>	GPS anti-jamming enabled \$PHD,06,15,HU,,0002,8*79<CR><LF> Beidou anti-jamming enabled \$PHD,06,15,HU,,0020,8*79<CR><LF> GPS+Beidou anti-jamming enabled \$PHD,06,15,HU,,0022,8*7B<CR><LF>

## CFG-PPS 1PPS Delay Compensation Setting

Command Definition: 1PPS signal is provided through a designated output pin for external applications. The pulse is active every second and the required duration can be set up by programming user-defined settings.

Because the wire length of a module’s GPS antenna may cause the 1PPS output signal to be delayed, Sierra Wireless provides a customized firmware command to compensate 1PPS timing pulse to provide a precise and synchronized time at every location.

---

*Note: The 1PPS delay time set will revert back to the default value when the module is powered on or reset.*

---

Send Command Data Field Message Structure:

(Refer to [Table 1-1](#) on page 5 and [Table 1-3](#) on page 6 for details.)

Start	Class ID	Message ID	Send Payload Length	Return Payload Length	Payload Parameter	Checksum	End
\$PHD	06	07	TITUUU	BB	See table below	CK_1 CK_2	<CR><LF>

Payload Parameter (total 15 bytes):

Byte Offset	Name	Description	Default Value
0-4	Period (µs)	One elapsed cycle time of PPS in microsecond. Range: 0-1000000	1000000µs
4-8	Offset (ns)	Pulse delay defined by the user	50ns
8-12	Duty cycle (%)	Ration of active parts in PPS. The scale is 10 <sup>-6</sup> Range: 0-1000000	100000 (10%)
12-13	Polarity	Pulse polarity at the start of PPS 0: Falling edge at start of second 1: Rising edge at start of second	1
13-14	GPIO	Range: 0-15	13
14-15	Sync	0: Only output PPS when fixing 1: Keep PPS even when there is no position fix	0

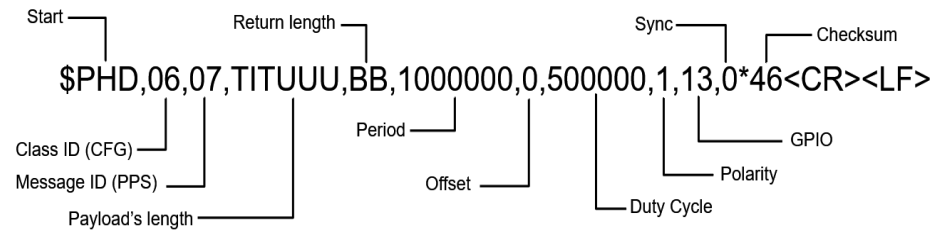

Figure 2-23: Set 1PPS Delay Example

Response Sentence Field (refer to [Figure 2-1](#) on page 9 for details):

`$PHD,05,01,BB,,06,07*59a`

Example:

Command	Response
<code>\$PHD,06,07,TITUUU,BB,1000000,0,500000,1,13,0*46&lt;CR&gt;&lt;LF&gt;</code>	<code>\$PHD,05,01,BB,,06,07*59 &lt;CR&gt;&lt;LF&gt;</code>

## CFG-PPS Query 1PPS Delay Compensation

Command Definition: Query 1PPS delay compensation settings

Send Command Data Field Message Structure:

(Refer to [Table 1-1](#) on page 5 and [Table 1-3](#) on page 6 for details.)

Start	Class ID	Message ID	Send Payload Length	Return Payload Length	Payload Parameter	Checksum	End
\$PHD	06	07	NULL	TITUU	None	CK_1 CK_2	<CR><LF>

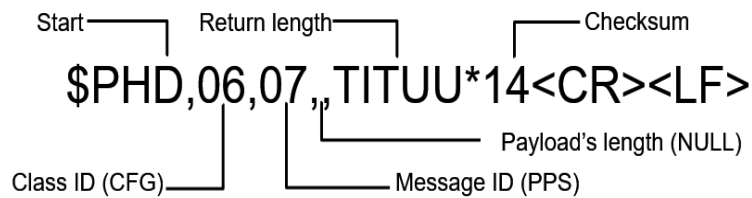

Figure 2-24: Query 1PPS Delay Compensation Example

Response Sentence Field Message Structure:

(Refer to [Table 1-1](#) on page 5 and [Table 1-3](#) on page 6 for details.)

Start	Class ID	Message ID	Send Payload Length	Return Payload Length	Payload Parameter	Checksum	End
\$PHD	06	07	TITUU	NULL	See table below	CK_1 CK_2	<CR><LF>

Payload Parameter (total 14 bytes):

Byte Offset	Name	Description	Default Value
0-4	Period (μs)	One elapsed cycle time of PPS in microsecond	1000000μs
4-8	Offset (ns)	Pulse delay defined by the user	50ns
8-12	Duty Cycle (%)	Ratio of active part in PPS Scale is 10 <sup>-6</sup>	100000 (10%)
12-13	Polarity	Pulse polarity at the start of PPS 0: Falling edge at start of second 1: Rising edge at start of second	1
13-14	GPIO	Range: 0-15	13

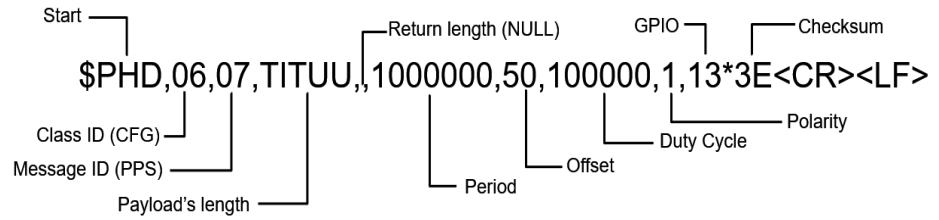

Figure 2-25: Query PPS Delay Compensation Response Example

Example:

Command	Response
\$PHD,06,07,,TITUU*14<CR><LF>	\$PHD,06,07,TITUU,,1000000,50,100000,1,13*3E<CR><LF>

## CFG-EPHSAVE Ephemeris Runtime Flash Saving Setting

Command Definition: Save ephemeris into runtime flash. This function will speed up TTF time. (This is a HEX array command.)

Send Command Data Field Message Structure:

Start	Class ID	Message ID	Payload Length (little-endian)	Payload Parameter	Checksum
0xF1 0xD9	0x06	0x10	0x01 0x00	See table below	CK_1 CK_2

Payload Parameter (total 1 byte):

Byte Offset	Name	Description
0-1	EPH status	0x00: Disable 0x01: Enable

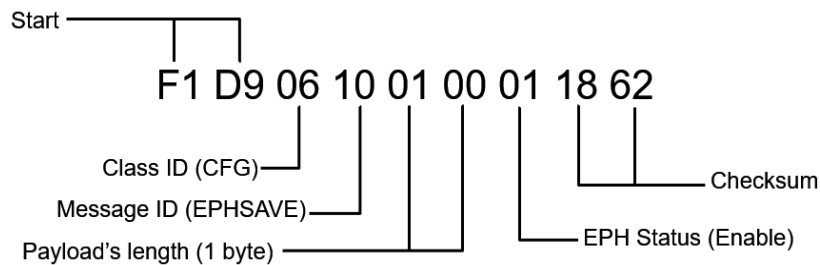

Figure 2-26: Set EPH Setting Example

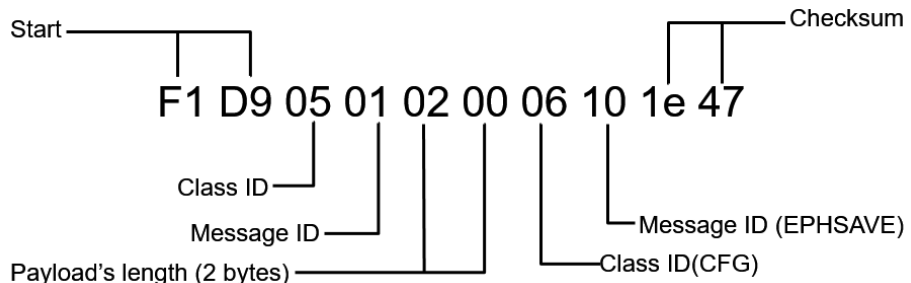

Figure 2-27: Set EPH Setting Response

Example:

Command	Response
F1 D9 06 10 01 00 01 18 62 (Enable EPH)	F1 D9 05 01 02 00 06 10 1E 47
F1 D9 06 10 01 00 00 17 61 (Disable EPH)	

*Note: This command does not require a line break symbol (<CR><LF>). This feature will increase the read and write of the flash memory so it is possible to reduce the life of the flash memory.*

If you want to implement this command on your host, send this command by HEX array without any blanks. For example:

```
byte[] EPHCMD = { 0xF1, 0xD9, 0x06, 0x10, 0x01, 0x00, 0x01, 0x18, 0x62 };
```

## CFG-EPHSAVE Query Ephemeris Runtime Flash Saving Status

Command Definition: Query EPH setting status. (This is a HEX array command.)

Send Command Data Field Message Structure:

Start	Class ID	Message ID	Payload Length (little-endian)	Payload Parameter	Checksum
0xF1 0xD9	0x06	0x10	0x00 0x00	None	CK_1 CK_2

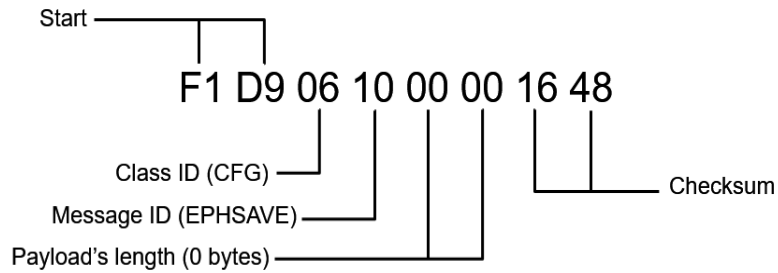

Figure 2-28: Query EPH Settings Status Example

Response Sentence Field Message Structure:

Start	Class ID	Message ID	Payload Length (little-endian)	Payload Parameter	Checksum
0xF1 0xD9	0x06	0x10	0x01 0x00	See table below	CK_1 CK_2

Payload Parameter (total 1 byte):

Byte Offset	Name	Description
0-1	EPH status	0x00: Disable 0x01: Enable

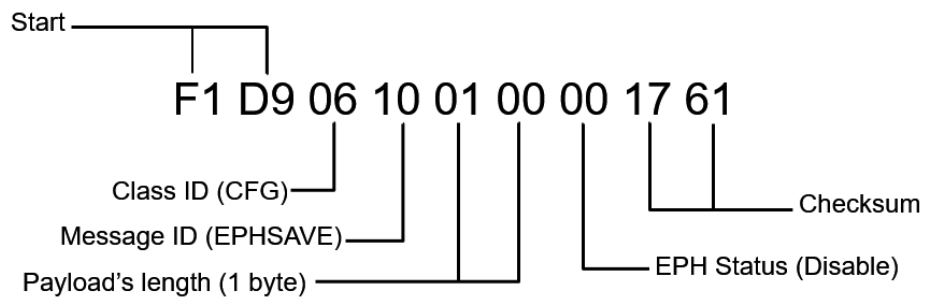

Figure 2-29: Query EPH Settings Status Response Example

Example:

Command	Response
F1D9061000001648	F1D906100100011862 (Enable EPH) F1D906100100001761 (Disable EPH)

Note: This command does not require a line break symbol (<CR><LF>).

If you want to implement this command on your host, send this command by HEX array without any blanks. For example:

```
byte[] EPHCMD = { 0xF1, 0xD9, 0x06, 0x10, 0x00, 0x00, 0x16, 0x48 };
```

## CFG-MSG Setting NMEA Output Rate

Command Definition: Set NMEA sentence output frequencies

Send Command Data Field Message Structure:

(Refer to [Table 1-1](#) on page 5 and [Table 1-3](#) on page 6 for details.)

Start	Class ID	Message ID	Send Payload Length	Return Payload Length	Payload Parameter	Checksum	End
\$PHD	06	01	BUU	BB	See table below	CK_1 CK_2	<CR><LF>

Payload Parameter (total 3 bytes):

Byte Offset	Name	Description
0-1	F0	Fixed value
1-2	NMEA sentence ID	0: GGA 1: GLL 2: GSA 3: GRS 4: GSV 5: RMC 6: VTG 7: ZDA 8: GST
2-3	Rate	Send rate on I/O target

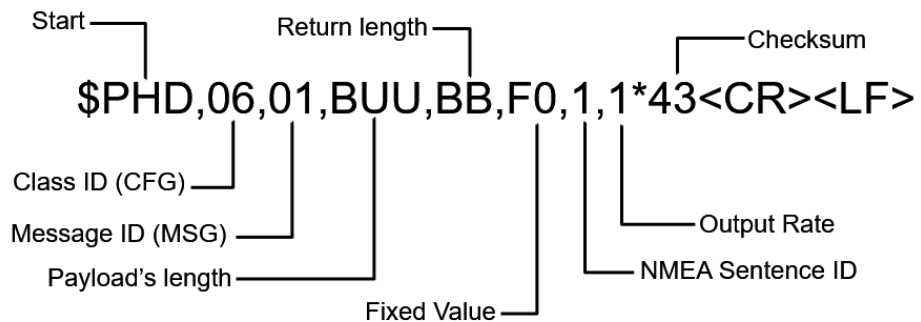

Figure 2-30: Set GLL Output per Second Example

Response Sentence Field (refer to [Figure 2-1](#) on page 9 for details):

\$PHD,05,01,BB,,06,01\*5F

Example:

Command	Response
Example of setting VTG output per second: \$PHD,06,01,BUU,BB,F0,6,1*44<CR><LF>	\$PHD,05,01,BB,,06,01*5F<CR><LF>

## CFG-MSG Query NMEA Output Rate

Command Definition: Query the output frequency of NMEA sentence

Send Command Data Field Message Structure:

(Refer to [Table 1-1](#) on page 5 and [Table 1-3](#) on page 6 for details.)

Start	Class ID	Message ID	Send Payload Length	Return Payload Length	Payload Parameter	Checksum	End
\$PHD	06	01	BU	BUU	See table below	CK_1 CK_2	<CR><LF>

Payload Parameter (total 2 bytes):

Byte Offset	Name	Description
0-1	F0	Fixed value
1-2	NMEA sentence ID	0: GGA 1: GLL 2: GSA 3: GRS 4: GSV 5: RMC 6: VTG 7: ZDA 8: GST

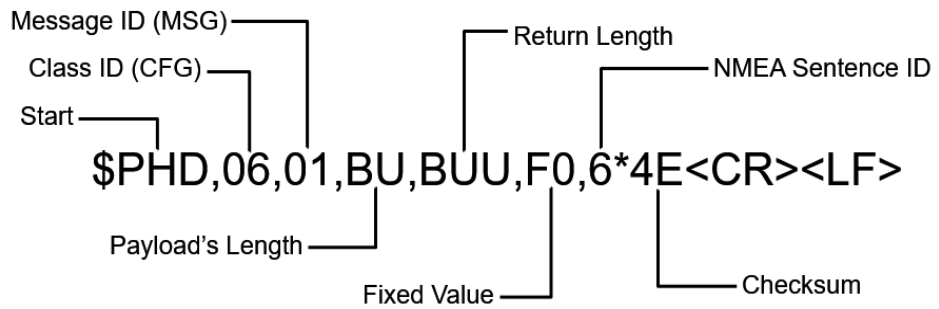

Figure 2-31: Query VTG Output Frequency Example

Response Sentence Field Message Structure:

(Refer to [Table 1-1](#) on page 5 and [Table 1-3](#) on page 6 for details.)

Start	Class ID	Message ID	Send Payload Length	Return Payload Length	Payload Parameter	Checksum	End
\$PHD	06	01	BUU	NULL	See table below	CK_1 CK_2	<CR><LF>

Payload Parameter (total 3 bytes):

Byte Offset	Name	Description
0-1	F0	Fixed value
1-2	NMEA sentence ID	0: GGA 1: GLL 2: GSA 3: GRS 4: GSV 5: RMC 6: VTG 7: ZDA 8: GST
2-3	Rate	Send rate on I/O target

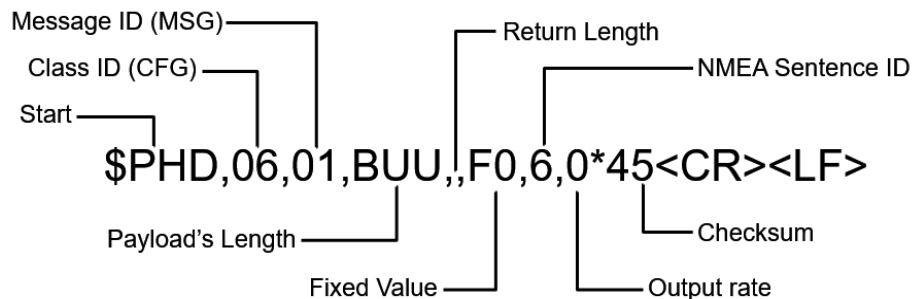

Figure 2-32: Query VTG Output Frequency Response Example

Example:

Command	Response
Example of sending command to query the VTG output frequency: \$PHD,06,01,BU,BUU,F0,6*4E<CR><LF>	\$PHD,06,01,BUU,,F0,6,0*45<CR><LF>

## CFG-CFG Save and Clear Current Configuration

Command Definition: Save and clear current configuration

Send Command Data Field Message Structure:

(Refer to [Table 1-1](#) on page 5 and [Table 1-3](#) on page 6 for details.)

Start	Class ID	Message ID	Send Payload Length	Return Payload Length	Payload Parameter	Checksum	End
\$PHD	06	09	TT	BB	See table below	CK_1 CK_2	<CR><LF>

Payload Parameter (total 3 bytes):

Byte Offset	Name	Description
0-4	Action	0: Save the configuration in flash 1: Load the configuration in flash 2: Clear the configuration in flash
4-8	Mask	1: Baudrate 2: NMEA sentence rate 4: Navigation setting (satellite setting or NMEA version) 4294967295: Factory reset to firmware default value

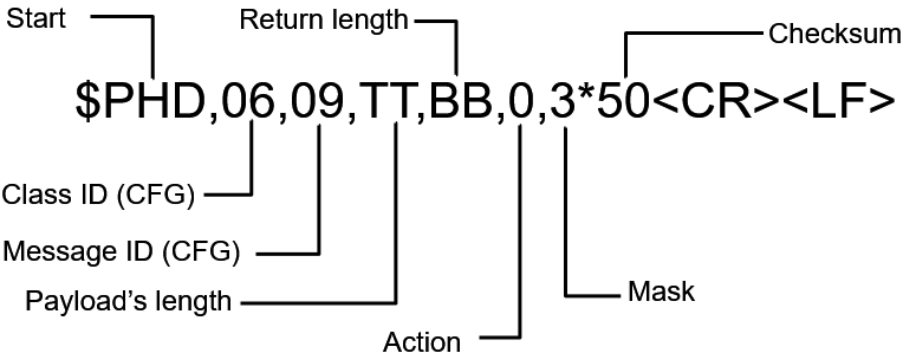

Figure 2-33: Save Baud Rate and NMEA Sentence Rate Example

Response Sentence Field (refer to [Figure 2-1](#) on page 9 for details):

\$PHD,05,01,BB,,06,01\*5F

Example:

Command	Response
Loading baud rate, NMEA sentence rate and navigation setting: \$PHD,06,09,TT,BB,1,7*55 <CR><LF>	\$PHD,05,01,BB,,06,09*57<CR><LF>

If you want to check multiple masks, add the numbers together. That is, the mask of Baud rate + NMEA message rate + Navigation setting is 7.

If it is an individual reset, you need to manually restart the module to clear the configuration; if you use factory reset, the module will automatically restart.