



# AirLink ES Series

## Hardware User Guide



**SIERRA**  
WIRELESS™

4116746  
Rev 6



---

## Important Notice

Due to the nature of wireless communications, transmission and reception of data can never be guaranteed. Data may be delayed, corrupted (i.e., have errors) or be totally lost. Although significant delays or losses of data are rare when wireless devices such as the Sierra Wireless modem are used in a normal manner with a well-constructed network, the Sierra Wireless modem should not be used in situations where failure to transmit or receive data could result in damage of any kind to the user or any other party, including but not limited to personal injury, death, or loss of property. Sierra Wireless accepts no responsibility for damages of any kind resulting from delays or errors in data transmitted or received using the Sierra Wireless modem, or for failure of the Sierra Wireless modem to transmit or receive such data.

## Safety and Hazards

Do not operate the Sierra Wireless modem in areas where blasting is in progress, where explosive atmospheres may be present, near medical equipment, near life support equipment, or any equipment which may be susceptible to any form of radio interference. In such areas, the Sierra Wireless modem **MUST BE POWERED OFF**. The Sierra Wireless modem can transmit signals that could interfere with this equipment.

The driver or operator of any vehicle should not operate the Sierra Wireless modem while in control of a vehicle. Doing so will detract from the driver or operator's control and operation of that vehicle. In some states and provinces, operating such communications devices while in control of a vehicle is an offence.

## Limitation of Liability

The information in this manual is subject to change without notice and does not represent a commitment on the part of Sierra Wireless. SIERRA WIRELESS AND ITS AFFILIATES SPECIFICALLY DISCLAIM LIABILITY FOR ANY AND ALL DIRECT, INDIRECT, SPECIAL, GENERAL, INCIDENTAL, CONSEQUENTIAL, PUNITIVE OR EXEMPLARY DAMAGES INCLUDING, BUT NOT LIMITED TO, LOSS OF PROFITS OR REVENUE OR ANTICIPATED PROFITS OR REVENUE ARISING OUT OF THE USE OR INABILITY TO USE ANY SIERRA WIRELESS PRODUCT, EVEN IF SIERRA WIRELESS AND/OR ITS AFFILIATES HAS BEEN ADVISED OF THE POSSIBILITY OF SUCH DAMAGES OR THEY ARE FORESEEABLE OR FOR CLAIMS BY ANY THIRD PARTY.

Notwithstanding the foregoing, in no event shall Sierra Wireless and/or its affiliates aggregate liability arising under or in connection with the Sierra Wireless product, regardless of the number of events, occurrences, or claims giving rise to liability, be in excess of the price paid by the purchaser for the Sierra Wireless product.

## Patents

This product may contain technology developed by or for Sierra Wireless Inc. This product includes technology licensed from QUALCOMM®. This product is manufactured or sold by Sierra Wireless Inc. or its affiliates under one or more patents licensed from InterDigital Group and MMP Portfolio Licensing.

## Copyright

© 2017 Sierra Wireless. All rights reserved.

## Trademarks

Sierra Wireless®, AirPrime®, AirLink®, ALEOS® and the Sierra Wireless logo are registered trademarks of Sierra Wireless.

Windows® is a registered trademark of Microsoft Corporation.

Macintosh® and Mac OS X® are registered trademarks of Apple Inc., registered in the U.S. and other countries.

QUALCOMM® is a registered trademark of QUALCOMM Incorporated. Used under license.

Other trademarks are the property of their respective owners.

## Contact Information

Sales information and technical support, including warranty and returns	Web: <a href="http://sierrawireless.com/company/contact-us/">sierrawireless.com/company/contact-us/</a> Global toll-free number: 1-877-687-7795 6:00 am to 6:00 pm PST
Corporate and product information	Web: <a href="http://sierrawireless.com">sierrawireless.com</a>



# Contents

<b>Introducing the AirLink ES Series</b> .....	<b>9</b>
Introduction .....	9
Out-of-Band Management (OOBM) .....	10
Network Configuration .....	11
Device Description .....	11
Front Panel .....	11
Rear Panel .....	12
ALEOS Software .....	13
ACEmanager .....	14
ACEview .....	14
AirLink Management Service .....	14
Accessories .....	15
Ordering Information .....	15
Warranty .....	15
<b>Startup and Configuration</b> .....	<b>17</b>
Initial Startup and Configuration .....	17
Tools and Materials Required .....	17
Installing the SIM Card .....	18
Connecting the Antennas .....	18
Connecting the Power Cable and Starting the ES Series Device .....	20
Connecting the Configuration PC .....	20
Connecting the Enterprise Router or other Equipment .....	21
Configuring with ACEmanager .....	23
Configuring with AirLink Management Service .....	25
Configuring with AT Commands .....	26
LED Behavior .....	26
Recovery Mode .....	29

<b>On-site Installation and Setup</b> .....	<b>31</b>
Typical Configuration .....	31
Locating the ES Series device .....	32
Mounting the ES Series device .....	33
Antenna Installation .....	33
Antenna Recommendations .....	34
Antenna Separation .....	34
Connecting the Enterprise Router .....	35
Power Connector on the ES Series Gateway .....	35
Fusing .....	36
Grounding the ES Series Gateway Chassis .....	36
Local Management .....	39
Remote Management .....	39
<b>AirLink ES Series Specifications</b> .....	<b>41</b>
Radio Module Conducted Transmit Power .....	45
Host Interfaces .....	48
Environmental .....	48
Mechanical Specifications .....	51
Antenna Specifications .....	52
<b>Regulatory Information</b> .....	<b>53</b>
Federal Communications Commission Notice (FCC United States) .....	53
Important Information for North American Users on Radiation Exposure .....	53
Europe Generic Devices .....	54
<b>Accessories</b> .....	<b>55</b>
DC Power Cable (Black Connector) .....	55

AC Power Adapter (Black Connector) . . . . .	56
AC Power Adapter Input . . . . .	56
AC Power Adapter Output . . . . .	56
AC Power Adapter Environmental Specifications . . . . .	57
AC Power Adapter Reliability and Quality Control . . . . .	57
AC Power Adapter Safety Standards . . . . .	57
AC Power Adapter EMC Standards . . . . .	58
AC Power Adapter Hazardous Substances . . . . .	58
AC Power Adapter Energy Efficiency . . . . .	58
<b>Acronyms . . . . .</b>	<b>59</b>
<b>Index . . . . .</b>	<b>63</b>



# 1: Introducing the AirLink ES Series

1

This chapter describes the Sierra Wireless AirLink ES Series device, including a description of ALEOS<sup>®</sup> embedded software and the AirLink Management Service (ALMS) device management platform.

## Introduction

The Sierra Wireless ES Series enterprise gateways deliver mission-critical 4G LTE connectivity when primary landline connections are unavailable. When deployed with an enterprise router, ES Series devices support a best-in-class business continuity strategy by enabling out-of-band management (OOBM) capability to network operations while leveraging the router's instant failover, routing, and firewall features.

You can also configure ES Series devices to send their management data via the DSL/cable gateway using reliable static route protocol to reduce wireless network costs.

Additional benefits to this enterprise-class business continuity solution include:

- Improved Internet uptime to keep your branches, kiosks, and retail operations online
- Seamless failover for continuous uptime of mission critical applications
- High speed LTE network, faster than xDSL
- Reduced field visits for network equipment resets and updates
- ALEOS and ACEmanager web-based configuration that makes it quick to deploy
- AirLink Management Service cloud-based device management application that works in parallel with your network management systems to manage the wireless system
- ALEOS reliable connection software ensures that the ES Series device stays connected to the wireless network
- Better SLAs (Service Level Agreements) offered from the Network Operation Centers as a result of the wireless backup offered by ES Series devices

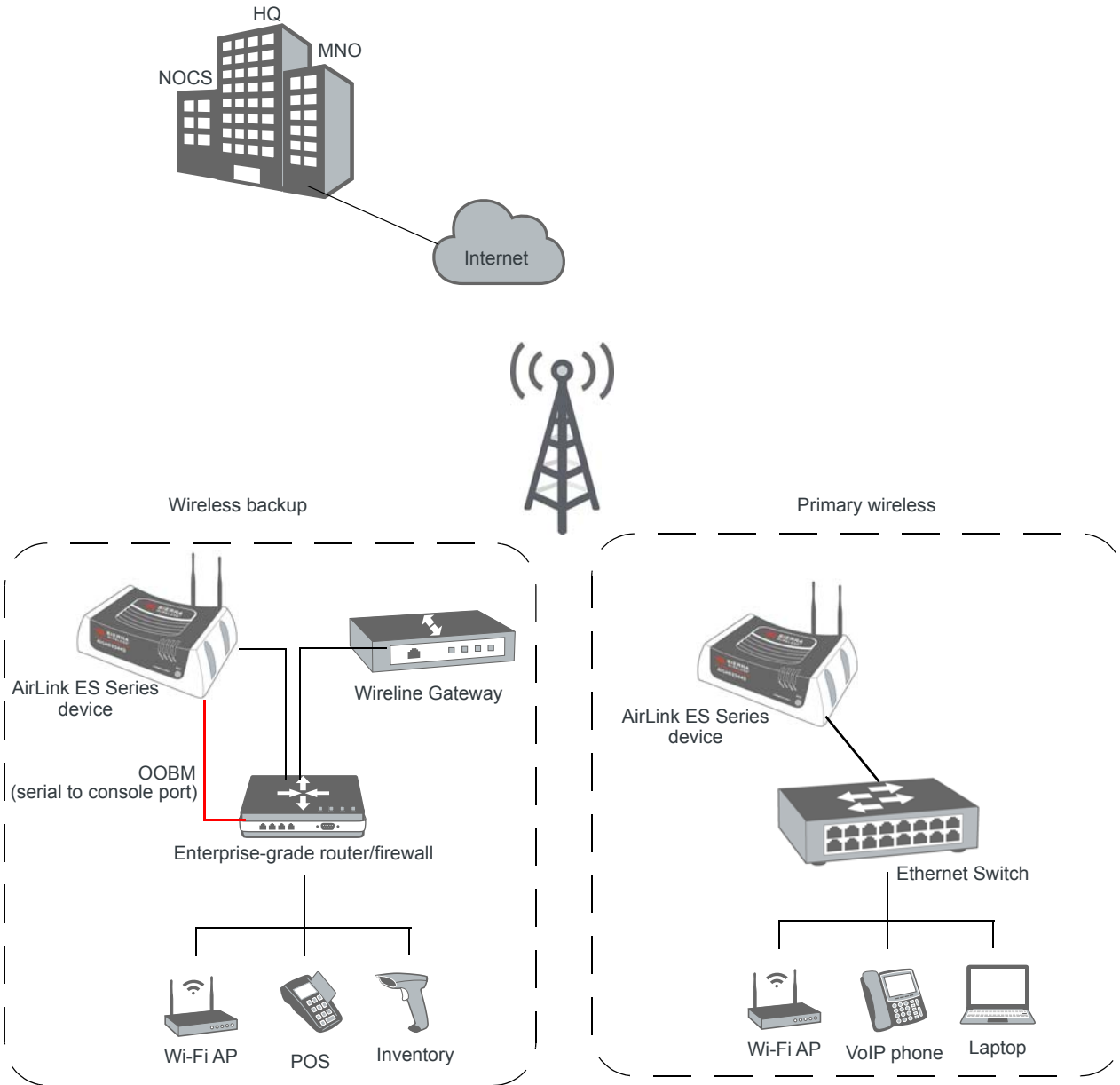

Figure 1-1: AirLink ES Series applications

## Out-of-Band Management (OOBM)

Using the ES Series device's serial port to connect to the console port of the router, IT administrators can troubleshoot and repair network equipment over wireless wide area networks (WANs). This terminal server capability allows operation centers to remotely reboot, configure, and update the BIOS of a router via the ES Series enterprise gateway using Reverse Telnet and SSH protocols. As a result, remote personnel no longer need to manually reset their networking equipment and IT administrators can dramatically reduce the number of field visits.

## Network Configuration

ES Series devices are designed for the distributed enterprise, which includes any enterprise that has remote facilities that must maintain a network connection for critical business processes such as retail credit card transactions.

If you are using an ES Series device for a point-of-sales application, you can configure it to meet PCI Data Security Standard compliance requirements. ALEOS features such as Reverse Telnet and Reliable Static Routing also support point-of-sale applications. Refer to the ALEOS Software Configuration User Guide for details.

## Device Description

### Front Panel

The front panel has the following indicators and controls:



Figure 1-2: ES Series Device Front Panel

- **LEDs** – These show the ES Series device's operating status. The LEDs are described in detail in [LED Behavior](#) on page 26.
- **Reset Button** – Momentarily pressing and releasing this button reboots the ES Series device.

---

*Note: Holding the Reset button down for 7–10 seconds resets the ES Series device to its factory default settings.*

---

## Rear Panel

The rear panel has the following connectors and controls:

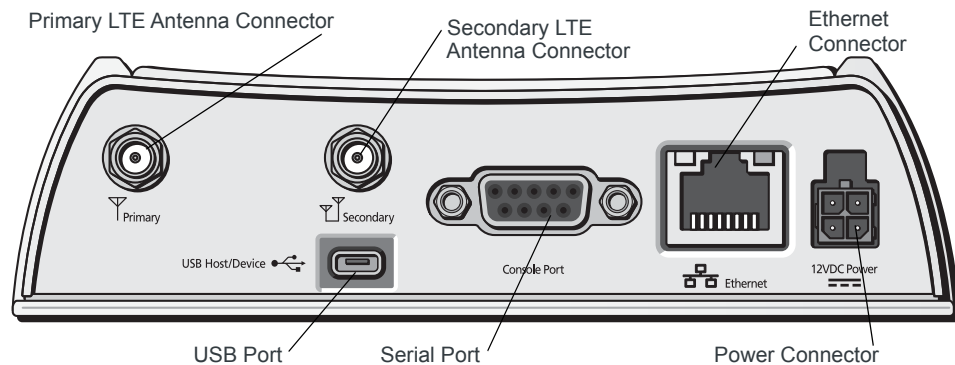

Figure 1-3: ES Series Rear Panel

- **Primary LTE Antenna Connector** – This is the radio’s receive and transmit port. For best results, use the included antennas, placed in a V formation. You can attach the antennas directly to the ES Series device, or you can use a bracket and SMA coaxial cable to connect antennas located away from the device.
- **Secondary LTE Antenna Connector** – This is required for LTE MIMO (multiple-input and multiple-output).

---

*Note:* For more information, see [Connecting the Antennas](#) on page 18.

---

- **Ethernet Connector** – This RJ-45 connector connects any Ethernet-enabled network equipment to the ES Series device using a standard Ethernet cable. It is also used to connect a Windows PC that you can use to configure and monitor the ES Series device, using ACEmanager.  
This connector complies with the IEEE 802.3 specification for 100 Mbps speed (Fast Ethernet) with fallback to 10 Mbps and includes auto-crossover support. It is auto-sensing and auto-detects the speed of the connecting device for 100 baseT or 10 baseT.  
The connector has two LEDs that indicate speed and activity. For more information, see [Ethernet LEDs](#) on page 28.
- **Power Connector** – Connect the AC adapter or DC cable.  
The ES Series device automatically starts when power is supplied.
- **Serial Port** – This 9-pin connector provides standard RS-232 DCE communication. For out-of-band management, you can connect this serial port to an enterprise router. You can also connect a computer to the serial port to configure the ES Series device using AT commands. For more information, see [Connecting the Enterprise Router or other Equipment](#) on page 21.
- **USB Port** – The Micro AB connector complies with version 2.0 of the USB standard for high-speed operation. It accepts Micro A and Micro B plugs. You can connect a Windows PC to monitor and configure the ES Series device.

When connected to a PC, the USB port becomes either a:

- Virtual serial port (The ES Series device behaves as if the PC is connected to a standard serial port. The primary use of this interface is to send AT commands.)
- Virtual Ethernet port (The ES Series device behaves as if the PC is connected to an Ethernet port, allowing access to the Internet and ACEmanager. This is the default setting.)

Refer to the ALEOS Software Configuration User Guide for information on configuring the USB port. Windows drivers for the USB port are available at Sierra Wireless' download web site: [source.sierrawireless.com](http://source.sierrawireless.com).

When using the USB port:

- Use a USB 2.0 cable
- Connect directly to your computer for best throughput

## ALEOS Software

---

*Note: For detailed information on all of the features in ALEOS, see the ALEOS Software Configuration User Guide available for downloading from [source.sierrawireless.com](http://source.sierrawireless.com).*

---

ALEOS, the embedded core technology of the AirLink product line, provides:

- An always-on, always-aware, intelligent two-way connection for mission-critical applications
- Simplified setup, operation and maintenance of any wireless solution

ALEOS features include:

- Reverse Telnet for out-of-band management
- Reliable Static Routing
- SNMP
- Persistent Network Connectivity
- Over-The-Air (OTA) Upgrades
- Wireless Optimized TCP/IP
- Real-Time Notification
- Packet Level Diagnostics
- Device Management & Control

Sierra Wireless has two main applications for monitoring and configuring ES Series devices:

- **ACEmanager** – A web-based configuration tool for configuring a single AirLink device
- **AirLink Management Service (ALMS)** – A cloud-based device management service for monitoring and configuring fleets of ES Series devices.

ES Series devices also accept AT Commands.

## ACEmanager

ACEmanager is a web-based application used to configure and monitor ES Series devices. ACEmanager:

- Simplifies deployment
- Provides extensive monitoring, control and management capabilities
- Enables you to configure your ES Series device to meet your needs
- Monitors and controls your ES Series device remotely and in real-time
- Is accessed through a web browser connected to the ES Series device locally or over the air.

See [Configuring with ACEmanager](#) on page 23 to learn how to access ACEmanager.

## ACEview

ACEview is a Windows-based monitoring application for the PC with an easy to read interface. You can download ACEview free of charge from: [source.sierrawireless.com](http://source.sierrawireless.com).



Figure 1-4: ACEview Screen

---

*Note: ACEview requires the Microsoft .NET Framework v.2.0 and Microsoft Windows XP or later. Obtain the Microsoft .NET Framework from Microsoft at: <http://www.microsoft.com>.*

---

## AirLink Management Service

AirLink Management Service (ALMS) is a cloud-based application, accessible from your web browser. It provides remote monitoring and configuration for multiple AirLink ALEOS devices from a single computer.

ALMS features include:

- Device management as a service
- Advanced monitoring dashboards and alert notifications ensuring you always know the status of your ES Series devices
- Detailed configuration of all ALEOS parameters, including templates providing batch updates of pre-set configurations across multiple devices
- Over-the-air (OTA) firmware upgrades for all of your ES Series devices with a single operation

For more information about ALMS, go to [www.sierrawireless.com/ALMS](http://www.sierrawireless.com/ALMS).

## Accessories

- Included with the ES Series device:
  - AC power adapter with international plug options
  - Mounting screws
  - Two LTE antennas
  - Quick Start Guide
- Order separately:
  - Ethernet cable
  - DB-9 serial cable (6 ft and 25 ft lengths)
  - USB cable
  - Null modem cable

## Ordering Information

For more information or to place an order, contact:  
[airlinksales@sierrawireless.com](mailto:airlinksales@sierrawireless.com).

## Warranty

The ES Series device has a 3-year standard warranty.





## 2: Startup and Configuration

This chapter provides instruction for the initial device configuration, and describes the front panel LEDs.

### Initial Startup and Configuration

Follow the instructions in this section to do the initial startup and configuration for the ES Series device. For on-site installation and setup instructions, see [On-site Installation and Setup](#) on page 31.

### Tools and Materials Required

- A SIM card for your ES Series device (provided by your mobile network operator) if not already installed
- A Phillips screwdriver for removing the top cover
- A laptop computer with an Ethernet, USB, or serial cable for device management
- Two LTE wireless antennas (included) For indoor use only.
- AC power adapter (included)
- If wireless out-of-band management is required, a null modem cable to connect the ES Series device's RS-232 port to the enterprise router
- If you are mounting the antennas remotely from the ES Series device, you will need a coaxial cable, mounting brackets, and connectors. (For more information, see [Antenna Installation](#) on page 33.)

## Installing the SIM Card

If it is not already installed, insert a SIM card into the ES Series device before connecting any external equipment or powering it up.

- 1) Use a Phillips screwdriver to remove the four screws attaching the cover. Save the screws for re-installation.

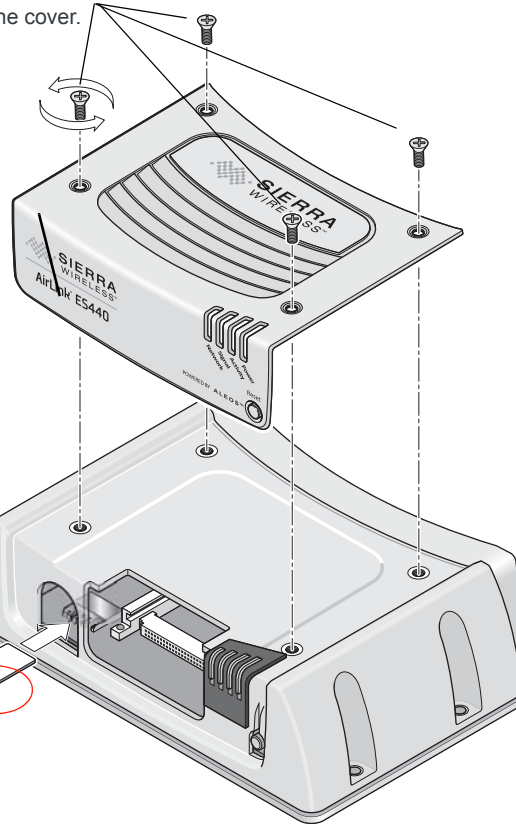

- 2) Remove the cover.

- 3) Slide the SIM card into the SIM card holder. Note the orientation of notched corner of SIM card for proper alignment.

- 4) Reattach the cover, ensuring that the Phillips screws are tightened to 5 in-lb (0.6 N-m). Over-tightening can damage the threads in the aluminum housing.

Figure 2-1: SIM Card Installation

## Connecting the Antennas

The primary and secondary RF antennas can be:

- Attached directly to the ES Series device  
They operate well when the antenna blades are placed in a V position, with 90 degrees of separation.
- Placed remotely using brackets, and connected to the ES Series device using a coaxial cable  
This may be required if you want to place the ES Series device in an area that does not have optimal signal strength or is near RF noise interference (such as near an enterprise router)

An RF site survey may be required to determine the best location. See [Antenna Installation](#) on page 33.

To connect the antennas to the device:

1. Connect both RF antennas, as shown in the illustration.



2. Adjust the antennas so they are in a V-formation, with a separation of 90 degrees.

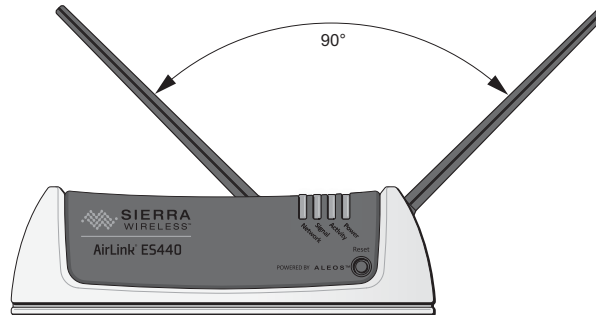

## Connecting the Power Cable and Starting the ES Series Device

1. Choose the correct AC adapter plug for your region and slide it into the AC adapter base.

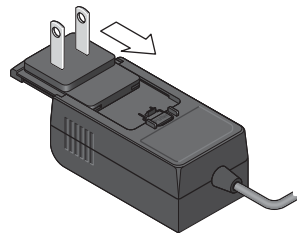

North America

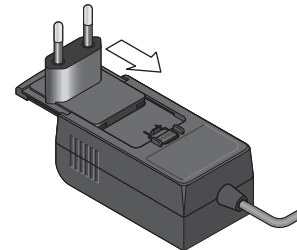

Europe

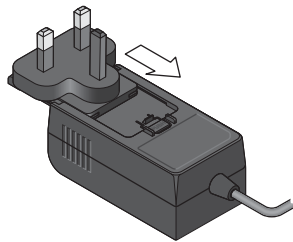

UK

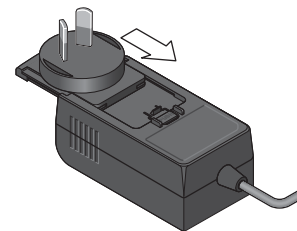

Australia

2. Connect the power cable to the 4-pin power connector on the ES Series device.
3. Plug the adapter into an AC wall outlet. (If you use a cable to connect the device to a DC power source, see [Power Connector on the ES Series Gateway](#) on page 35.)

Characteristics of the ES Series device power supply:

- 100–240 V
- 50/60 Hz.
- 9–36 VDC, 1500 mA output

4. The ES Series device starts automatically, as indicated by the flashing LEDs. See [LED Behavior](#) on page 26 for details.

## Connecting the Configuration PC

To connect the computer to the ES Series device:

1. Use an Ethernet cable to connect the ES Series device to the PC.  
If the Ethernet port is being used to connect another device, such as an enterprise router, you can connect the USB port on the ES Series device to the computer and configure it to act as a virtual Ethernet port. See [Figure 2-2](#) on page 21.

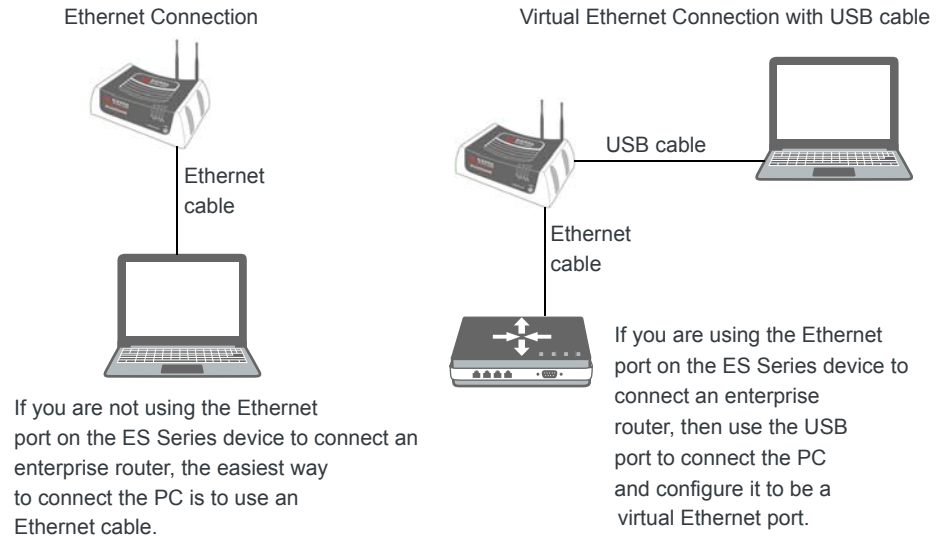

Figure 2-2: Connecting the ES Series device to the PC

2. If you are using a USB cable:
  - a. Download the USB drivers from [source.sierrawireless.com](http://source.sierrawireless.com).
  - b. Install the USB drivers.
  - c. Reboot the PC.
3. Use the appropriate cable (Ethernet or USB) to connect the PC to the ES Series device.

## Connecting the Enterprise Router or other Equipment

1. Use a serial cable to connect one of the WAN ports on the enterprise router to the RS-232 serial connector on the ES Series device.

---

*Note: The ES Series device is a DCE serial device. The enterprise router may have an RJ-45 or DB-9 console port. Depending on the type of console port connectors and the cable available from the enterprise router vendor, you may need to purchase additional cables, including a null modem cable from the enterprise router vendor.*

---

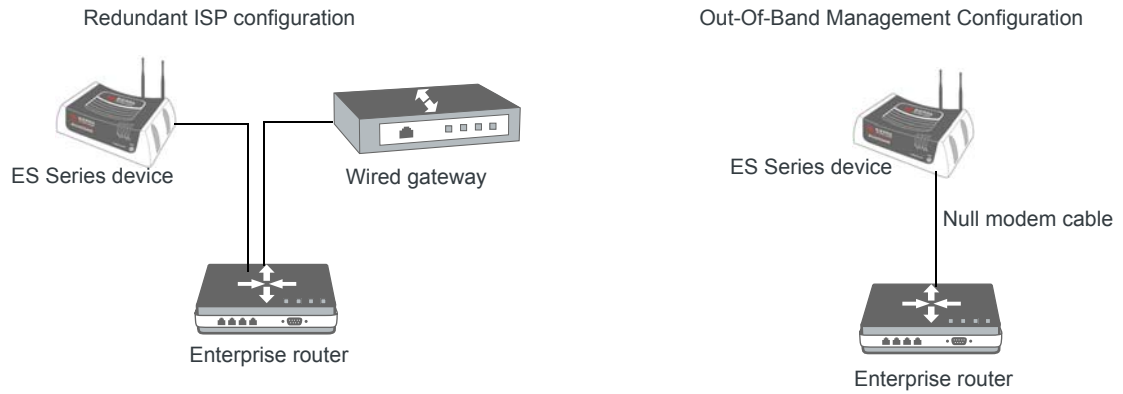

Figure 2-3: Connecting an enterprise router to an ES Series device

The ES Series device's serial connector complies with the EIA RS-232D specification for DCE equipment. The output driver levels range from -7 VDC to +7 VDC with normal loading.

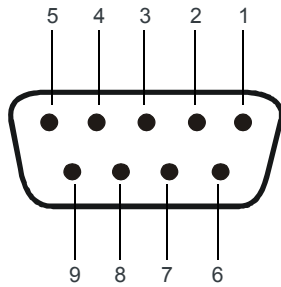

Figure 2-4: 9-Pin Serial Connector Diagram

**Table 2-1: Serial Connector Pin-out**

Name	Pin	Description	Type
DCD	1	Data Carrier Detect	OUT
TXD	2	Transmit Data	OUT
RXD	3	Receive Data	IN
DTR	4	Data Terminal Ready	IN
GND	5	Main GND. Connected internally to BOARD_GND	GND
DSR	6	Data Set Ready	OUT
RTS	7	Ready To Send	IN
CTS	8	Clear To Send	OUT
RI	9	Ring Indicator	OUT

## Configuring with ACEmanager

To access ACEmanager:

1. Ensure that the ES Series device is powered on and connected to a PC.
2. Open a web browser and in the address bar, enter:  
**http://192.168.13.31:9191.**

---

*Note: It may take a minute or two for the ES Series device to respond after the first power up.*

---

The ACEmanager login screen appears.

3. The default user name, user, is already entered. Enter the default password, **12345**.

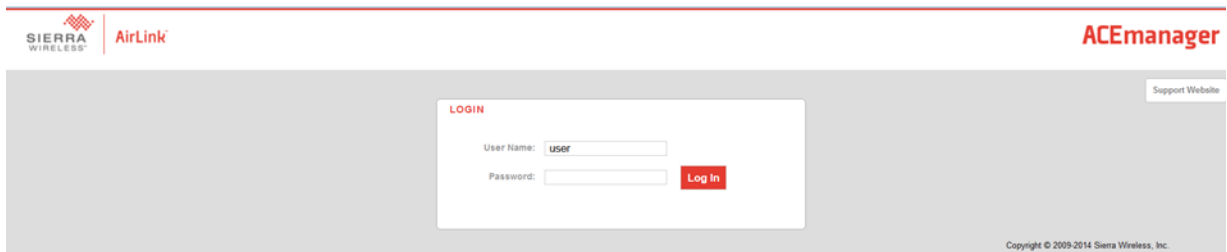

Figure 2-5: ACEmanager Login Screen

4. Click Log In.

The ACEmanager Status > Home page appears<sup>1</sup>.

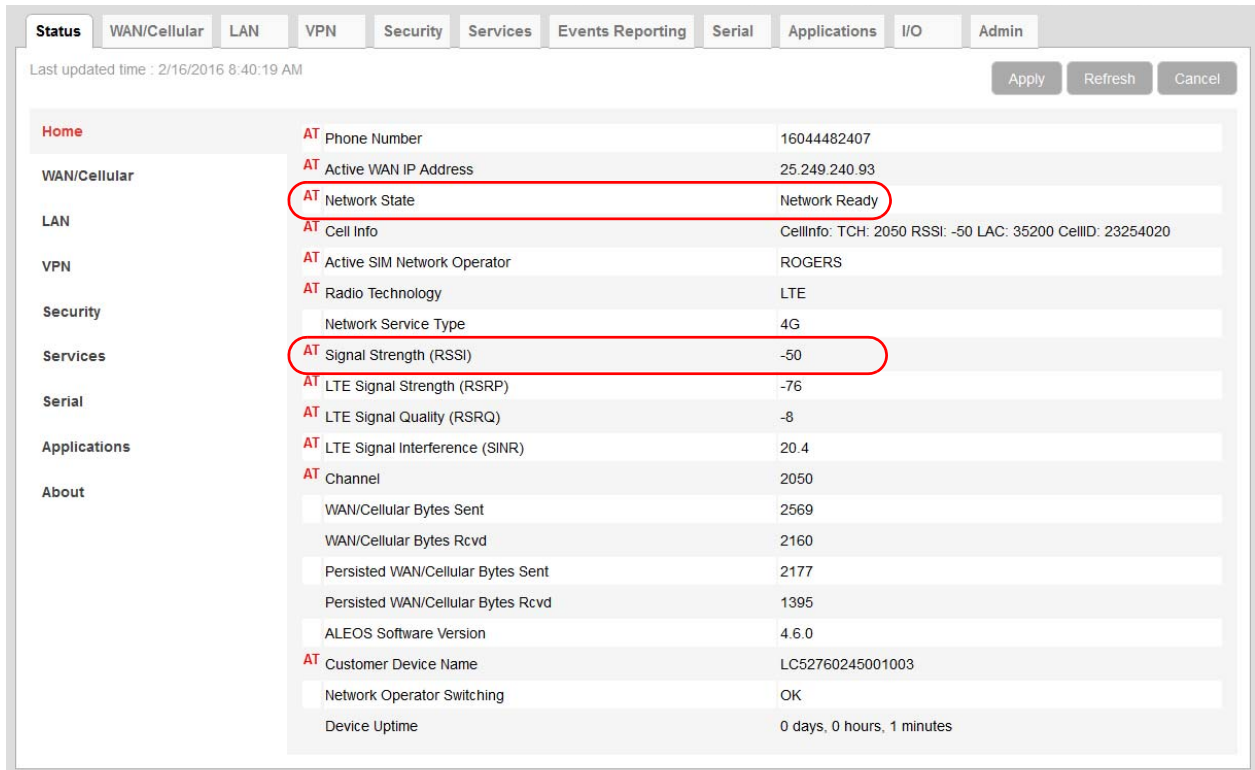

Figure 2-6: ACEmanager Homepage

5. If the device does not automatically connect to the network:
  - a. Check the Network State field. It should say “Network Ready”. If it says No SIM or Unexpected SIM, check that the correct SIM card is inserted. (See [Installing the SIM Card](#) on page 18.)
  - b. Check the Signal Strength field. It should be greater than -100.
  - c. Check the APN on the WAN/Cellular tab. If an error message appears in this field, contact your Mobile Network Operator. They may need to provide you with an APN to enter in the User Entered APN field.

1. The appearance of the screen varies depending on the version of ALEOS installed on the device and the type of network the device is connected to.

The screenshot displays the ACEmanager WAN/Cellular configuration interface. At the top, there are navigation tabs for Status, WAN/Cellular, LAN, VPN, Security, Services, Events Reporting, Serial, Applications, I/O, and Admin. Below the tabs, the page title is 'WAN/Cellular' and the last updated time is '11/18/2015 2:57:32 PM'. There are buttons for 'Expand All', 'Apply', 'Refresh', and 'Cancel'. The main configuration area is divided into sections: 'Reliable Static Route (RSR)', 'DMNR Configuration', and 'Advanced'. The 'Advanced' section is expanded, showing various settings for cellular connectivity. A red circle highlights the 'APN in Use' and 'AT User Entered APN' fields. Other settings include 'AT RX Diversity' (Disable), 'AT SIM PIN' (SIM PIN), 'Network Roaming Preference' (Automatic), 'Response to Incoming Ping' (No Response), 'AT Network Authentication Mode' (NONE), 'AT Network User ID', 'AT Network Password', 'AT Network Watchdog Timer' (Disable), 'AT Set Carrier [Operator] Selection', 'AT Checking SMS Status (seconds)', 'Cellular Network Watchdog' (Disable), 'LTE Active Reselection Interval' (Disabled), 'LTE Reselection Time' (15 Seconds), 'AT Current Radio Module Band', 'AT Setting for Band' (All bands), 'AT Always on connection' (Enabled), 'AT Connection timeout (minutes)', and 'On WAN Disconnect' (Reconnect). There are also expandable sections for 'APN Backup' and 'Bandwidth Throttle'.

Figure 2-7: ACEmanager: WAN/Cellular

To configure the device using ACEmanager, refer to the ALEOS Software Configuration User Guide, available for download from [source.sierrawireless.com](http://source.sierrawireless.com).

After the ES Series device is connected and configured, you can save the configuration as a template to the configuration PC and then apply this template to subsequent ES Series devices. For details, refer to the ALEOS Software Configuration User Guide.

## Configuring with AirLink Management Service

AirLink Management Service (ALMS) is a cloud-based service that provides remote monitoring and configuration for multiple AirLink devices.

To use ALMS, you must have an account. For more information, go to [www.sierrawireless.com/ALMS](http://www.sierrawireless.com/ALMS).

To access AirLink Management Service:

1. Connect a laptop to the ES Series device with an Ethernet cable.
2. Log in to ACEmanager.
3. Go to the Services tab and ensure that ALMS is enabled and the server URL is <http://na.m2mop.net/msci/com>. If this is not the case, enter the correct URL, click Apply and then click Reboot.
4. In your browser, go to <http://airvantage.net> and log in.
5. Follow the instructions in the online ALMS documentation to register your device.

## Configuring with AT Commands

You can also configure ES Series devices using AT commands over the RS-232 serial port or the USB port (configured as a virtual serial port). All the commands are listed in the ALEOS Software Configuration User Guide.

- Most AT commands are prefaced with AT. Exceptions are noted in the ALEOS Configuration User Guide.
- The acceptable format and parameters are listed with each command in the ALEOS Configuration User Guide.
- If you enter a recognized AT command, the ES Series device responds with “OK.” If the command is wrong, the ES Series device responds with “ERROR” or “Unsupported.”

## LED Behavior

**Table 2-2: LED Behavior**

LED	Color/Pattern	Description
<b>Power</b>	<b>Off</b>	No power or input voltage $\geq 36$ VDC or $\leq 9$ VDC
	<b>Solid Green</b>	Device is connected to nominal power and is operating normally.
	<b>Solid Amber</b>	Device is entering low power mode or system low level boot.
	<b>Solid Red</b>	Device is not operational (failure or in low power mode).
<b>Signal</b>	<b>Solid Green</b>	Good signal (RSSI $\geq -85$ dBm)
	<b>Solid Amber</b>	Marginal signal ( $-100$ dBm $<$ RSSI $<$ $-85$ dBm)
	<b>Solid Red</b>	Poor signal ( $-110$ dBm $\leq$ RSSI $\leq$ $-100$ dBm)
	<b>Flashing Red</b>	No signal (RSSI $<$ $-110$ dBm)

Table 2-2: LED Behavior

LED	Color/Pattern	Description
<b>Network</b>	<b>Solid Green</b>	Network Ready (LTE service available)
	<b>Flashing Amber / Green</b>	Network Ready (No LTE service available)
	<b>Flashing Green</b>	Network Ready—Roaming (LTE service available)
	<b>Flashing Amber / Green / Off</b>	Network Ready—Roaming (No LTE service available)
	<b>Flashing Amber</b>	No Service
	<b>Solid Amber</b>	Connecting to the network
	<b>Flashing Red</b>	Authentication/Negotiation failed (EV-DO only)
	<b>Solid Red</b>	Link Down No cellular network is present, no network coverage at current location, or the device is in radio passthru mode
<b>Activity (ALEOS 4.3.6 or earlier)</b>	<b>Off</b>	Normal operation
	<b>Flashing Green</b>	Traffic is being transmitted or received over the WAN interface.
<b>Activity (ALEOS 4.4.0 or later)</b>	<b>Off</b>	Normal operation
	<b>Flashing Green</b>	Traffic is being transmitted or received over the WAN interface.
	<b>Flashing Red</b>	Traffic is being transmitted or received over the serial port. (This behavior only appears if the AirLink ES Series device is configured to display it. Refer to the ALEOS Software Configuration Guide for details.)
	<b>Flashing Amber</b>	Traffic is being transmitted or received over both the WAN interface and the serial port. (This behavior only appears if the AirLink ES Series device is configured to display it. Refer to the ALEOS Software Configuration Guide for details.)
<b>All LEDs</b>	<b>Solid Amber</b>	When you press the reset button for more than 20 seconds, solid amber indicates when to release the reset button to enter Recovery mode. (See <a href="#">Recovery Mode</a> on page 29.)
	<b>Solid Red</b>	When you press the reset button for 7–10 seconds, solid red indicates when to release the reset button to return the gateway to the factory default settings. (See <a href="#">Reset to factory default settings</a> on page 28.)

## Ethernet LEDs

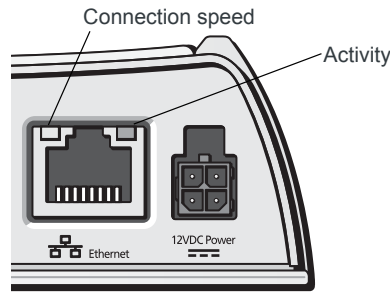

Figure 2-8: Ethernet LEDs

The Ethernet port has two LEDs that indicate speed and activity. When looking into the connector:

- **Activity**—The right LED is solid amber when a link is detected (the cable is plugged in) and blinks when there is activity.
- **Connection Speed**—The left LED is green to indicate a 100 Mbps connection and orange to indicate a 10 Mbps connection. It is off when no cable is connected.

## Power-up and Reboot

On power-up or reboot, the LEDs go through a booting sequence. When the boot is complete, the Power and Network LEDs should be green, signifying that the power is on, the ES Series device is connected to the wireless network, and there is a good signal. See [Table 2-2](#) for detailed LED operation.

To reboot the ES Series device, either:

- In ACEmanager, click the Reboot button at the top right of the screen.

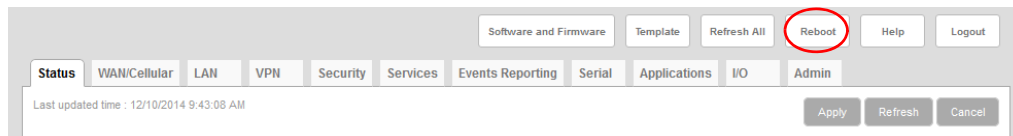

Or

- Press and release the Reset button on the ES Series device (see [Front Panel](#) on page 11).

## Reset to factory default settings

To reset the ES Series device to the factory default settings, either:

- Press and hold the Reset button until all the LEDs turn red (about 7–10 seconds). See [Front Panel](#) on page 11.

Or

- In ACEmanager, go to Admin > Advanced and click the Reset to Factory Default button. For details, refer to the ALEOS Software Configuration User Guide.

The ES Series device resets to the factory default settings and reboots. Once the reboot is complete and the LEDs resume their normal operating behavior, the reset is complete.

## Recovery Mode

If the router fails to boot properly, it automatically enters recovery mode, or, if the router is unresponsive to ACEmanager input and AT commands, you can manually put the router into recovery mode.

Recovery mode enables you to update the ALEOS software and return the router to working order. (For details, refer to the ALEOS Software Configuration User Guide—Configuring your router chapter.)

To enter Recovery mode manually:

- On the router, press the Reset button for more than 20 seconds. (Release the button when all the LEDs are solid amber.)

To recover the router:

- Update ALEOS using the Recovery mode interface. Once the new ALEOS version is successfully uploaded and installed, the gateway reboots and exits recovery mode. When the process is complete, the ACEmanager login screen appears.

---

*Note: After the recovery, you need to reload the radio module firmware store and templates.*

---

To exit Recovery mode, if it has been inadvertently entered, do one of the following:

- Press the reset button on the gateway to reboot it.
- Click the Reboot button on the Recovery screen.
- Wait 10 minutes. If no action is taken within 10 minutes of the device entering Recovery mode (for example, if the Recovery screen has not been loaded by the web browser), it automatically reboots and exits Recovery mode.

For more information, refer to the ALEOS Software Configuration User Guide (Configuring your router chapter).



## 3: On-site Installation and Setup

3

This chapter shows you how to communicate with and configure the Sierra Wireless AirLink ES Series device.

### Typical Configuration

The ES Series device is a purpose-built 4G LTE gateway and terminal server. When deployed with an enterprise router, the ES Series device supports a best-in-class business continuity strategy by enabling out-of-band management (OOBM) capability to network operations, while leveraging the router's instant failover, routing, and firewall features. [Figure 3-1](#) shows the typical connections.

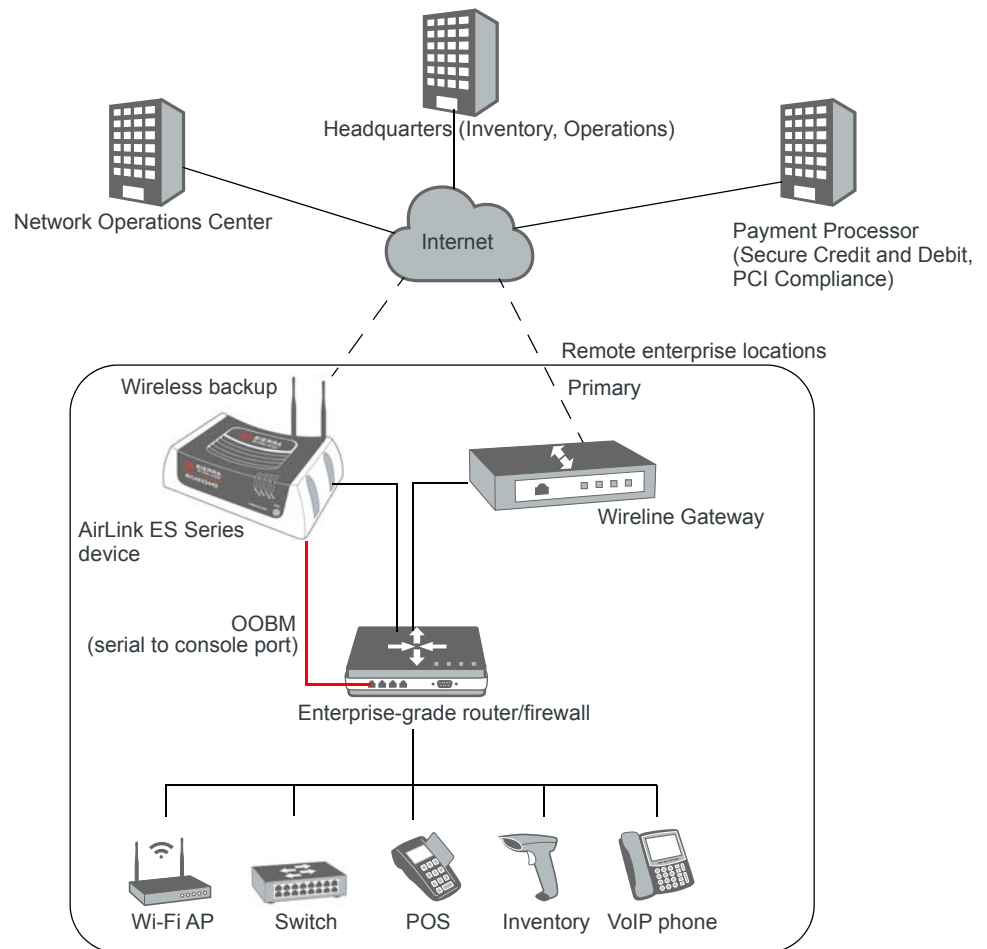

Figure 3-1: Network for Distributed Enterprise Business Continuity Model

When using the ES Series device in the configuration shown in [Figure 3-1](#), ensure that it has:

- An Ethernet connection to the enterprise router WAN port for failover with a wireline gateway
- A serial connection to the enterprise router console port for out-of-band management
- A USB connection to the local management PC
- A wireless WAN connection to the Mobile Network Operator (MNO)

And ensure that:

- Cables are secured to ensure reliable connections

The enterprise router performs the ISP failover by monitoring service on the WAN ports. The ES Series device is always attached to the MNO network and when the enterprise router sends traffic through the ES Series device, it passes through the MNO infrastructure to the enterprise systems, as shown in [Figure 3-1](#) on page 31.

If the remote site equipment needs attention, the OOBM feature of the ES Series device allows the NOC or IT administrator to perform OOBM tasks on the connected equipment using the ES Series device Reverse Telnet/SSH feature. This reduces the number of on-site trips and allows you to remotely manage connected equipment.

If the MNO offers better rates for minimal data usage, you can configure the ES Series device to reduce data transfer over the WWAN connection using the Reliable Static Route (RSR) feature to route data sourced from the ES Series device through the enterprise router primary connection. Refer to the ALEOS Software Configuration User Guide for information on configuring and using Reverse Telnet/SSH and RSR.

## Locating the ES Series device

Choosing where to place the ES Series device and the antennas to get the best performance can be a difficult task. The goal is to locate the ES Series device where it can connect to the enterprise router, have good signal coverage, and be in a low RF noise area. The options are:

- Place the ES Series device, with the antennas connected directly to it, in an area with good signal coverage that is away from the noise of other IT infrastructure equipment.  
Or
- Keep the ES Series device local to the IT infrastructure, place the antennas in an area with good signal coverage away from the noise of other electronic equipment, and cable the antennas to the ES Series device.

If you are experiencing RF performance-throughput issues and you do not have the equipment to perform an RF site survey to determine the best location, your Sierra Wireless authorized distributor may have the tools and knowledge to help.

For simple installations in good LTE coverage, an Ethernet-connected configuration PC running your favorite speed-test application and ACEmanager to determine network signal strength, cell info, and signal quality will help narrow down some of the location options.

## Mounting the ES Series device

**Warning:** *This ES Series device is not intended for use close to the human body. Antennas should be at least 8 inches (20 cm) away from the operator.*

Mount the ES Series device where:

- There is easy access to connect to the enterprise router and to the antennas (see [Locating the ES Series device](#) on page 32).
- The front panel LEDs are easily visible
- There is adequate airflow
- It is kept free from direct exposure to the elements, such as sun, rain, dust, etc.

The ES Series device has four mounting holes to attach it to a mounting surface. These holes are accessible from the top of the device and screws are provided for mounting.

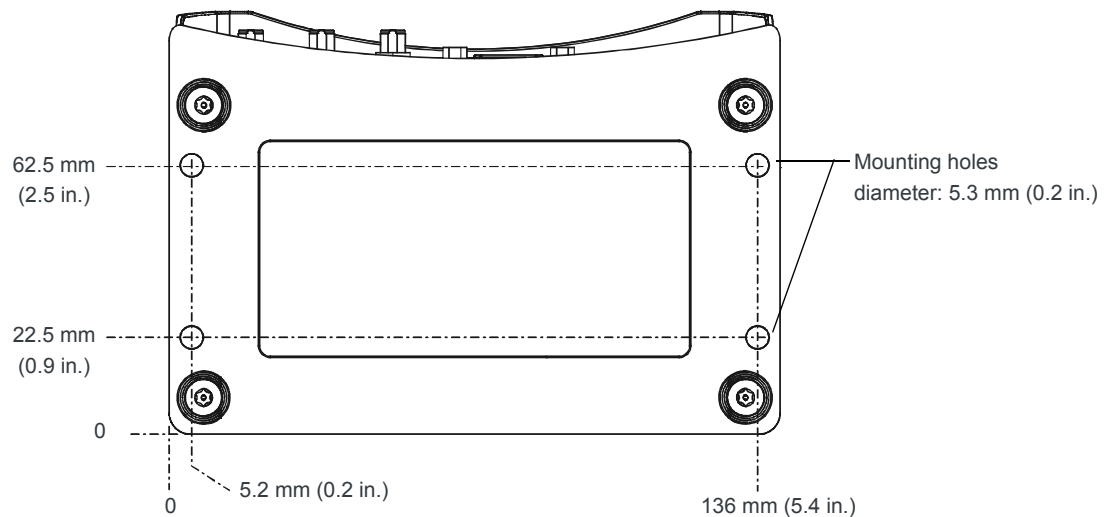

Figure 3-2: ES Series device bottom view, showing mounting holes

## Antenna Installation

If the location chosen in [Locating the ES Series device](#) on page 32 is such that the antennas can connect directly to the ES Series device, then follow the instructions in [Connecting the Antennas](#) on page 18 to connect the antennas in a V-formation.

If you are cabling the antennas to the ES Series device, your AirLink authorized reseller may be able to assist with your cabling and installation.

The included antennas are for indoor use only.

When placing either the included antennas or third-party antennas, follow the antenna separation guidelines in [Antenna Separation](#) on page 34 for optimum performance.

If you want to use a third-party antenna placed outdoors, Sierra Wireless recommends working with your authorized distributor to provide the proper protection, which may include an RF lightning arrester and/or Ethernet surge suppressors. The antenna must be installed by qualified personnel.

## Antenna Recommendations

---

*Note: Do not remove the secondary antenna. It helps the ES Series device achieve the maximum network coverage. The ES Series device works without one installed, but with reduced network coverage.*

---

---

*Note: If the antennas are located far away from the ES Series device, keep the cables as short as possible to prevent the loss of antenna gain.*

---

---

**Warning:** *In more complex installations (such as those requiring long lengths of cable and/or multiple connections), you must follow the maximum dBi gain guidelines specified by the radio communications regulations of the Federal Communications Commission (FCC) or Industry Canada or your country's regulatory body (if used outside the U.S.A.). Also see [Important Information for North American Users on Radiation Exposure](#) on page 53 for more information.*

---

## Antenna Separation

Inadequate antenna separation between the primary and secondary antennas creates unwanted interference that can cause reduction in:

- Antenna efficiency
- Transmit power
- Receiver sensitivity
- Data throughput
- Radio front-end life span

Antenna separation recommendations:

- The antennas should be separated so that there is at least 10 dB isolation over the entire operating frequency range.
- The separation should be at least 1/4 wavelength ( $\lambda$ ), but preferably 1/2 wavelength ( $\lambda$ ) or greater of the lowest operating frequency. See [Table 3-1](#) for specific recommendations, based on your network type and frequency.

Note: The values in the following table are approximate antenna separation values for monopole or dipole type antennas.

**Table 3-1: Recommended Antenna Separation**

Service	Frequency (MHz)	Wavelength ( $\lambda$ ) (mm)	Best Antenna Separation (mm) ( $1/2 \lambda$ )	Good Antenna Separation (mm) ( $1/4 \lambda$ )
4G LTE	700	428	214	107
4G LTE	800	375	187	94
4G LTE	900	333	167	83
4G LTE	1800	167	83	42
4G LTE	2100	143	71	36
4G LTE	2600	115	58	29
3G WCDMA HSPA	850	353	176	88
3G WCDMA HSPA	900	333	167	83
3G WCDMA HSPA	1900	158	79	39
3G WCDMA HSPA	2100	143	71	36
3G CDMA/EV-DO	800	375	187	94
3G CDMA/EV-DO	1900	158	79	39
2G GSM/GPRS/EDGE	850	353	176	88
2G GSM/GPRS/EDGE	900	333	167	83
2G GSM/GPRS/EDGE	1800	167	83	42
2G GSM/GPRS/EDGE	1900	158	79	39

## Connecting the Enterprise Router

See [Connecting the Enterprise Router or other Equipment](#) on page 21.

## Power Connector on the ES Series Gateway

If you are using the DC power cable to connect the ES Series gateway to a power source:

- Pin 1—Use the red wire in the DC cable to connect Pin 1 to the power source. Include a 2.0 A fast-acting fuse in the input power line. Sierra Wireless recommends using a continuous (unswitched) DC power source.

For installations that require the gateway to be turned on/off, Sierra Wireless recommends using the Ignition Sense (Pin 3) input for that purpose.

- Pin 2—Use the black wire in the DC cable to connect Pin 2 to ground. See also [Grounding the ES Series Gateway Chassis](#) on page 36.
- Pin 3 (Ignition Sense)—Sierra Wireless recommends always using the Ignition Sense wire to turn the gateway off. It should not be turned off by disconnecting power.

For installations where the ES Series gateway is turned on/off, use the white wire in the DC cable to connect Pin 3 to:

- A vehicle ignition for turning the ES gateway on with the ignition is one
- A low voltage monitor for turning the ES gateway off when the supply voltage drops below a defined level.

For installations where the ES gateway is permanently on (never turned on/off), connect the white wire to the red wire.

Pin 3 can be used as the trigger for the low power mode. For more information, refer to the ALEOS Software Configuration User Guide (Services chapter). If desired, you can also configure the ES Series gateway to notify you when it goes into Low Power mode. For details, refer the ALEOS Software Configuration User Guide (Events Reporting chapter).

---

*Note: Sierra Wireless strongly recommends that you use an unswitched VCC, with Pin 3 (white wire on DC cable) connected to the ignition (if you want the ES gateway on when the ignition is on) or connect it to a low voltage monitor (when you want the ES gateway to turn off when the voltage drops below a defined level. See [Figure 3-3](#) on page 37. This is particularly important for when the input power supply is not constant, such as vehicle installations.*

---

- [Pin 4 \(General Purpose I/O\)](#) (Optional)—Use the green wire in the DC cable to connect Pin 4 to a switch or relay on an external device you want to monitor. For more details, see [page 37](#).

See [Figure 3-3](#) and [Table 3-2](#).

## Fusing

For DC installations, Sierra Wireless recommends fusing the power input using a 2.0 A fast-acting fuse. Install the fuse on the positive line, as shown in [Figure 3-3](#) on page 37.

## Grounding the ES Series Gateway Chassis

For DC installations (with a fixed “system” ground reference), Sierra Wireless recommends always grounding the ES chassis or the mounting bracket to the system ground reference. To ensure a good grounding reference, use a short wire with a gauge of 18 AWG or larger connected to one of the mounting holes with the screws and lock washers provided in the supplied mounting kit.

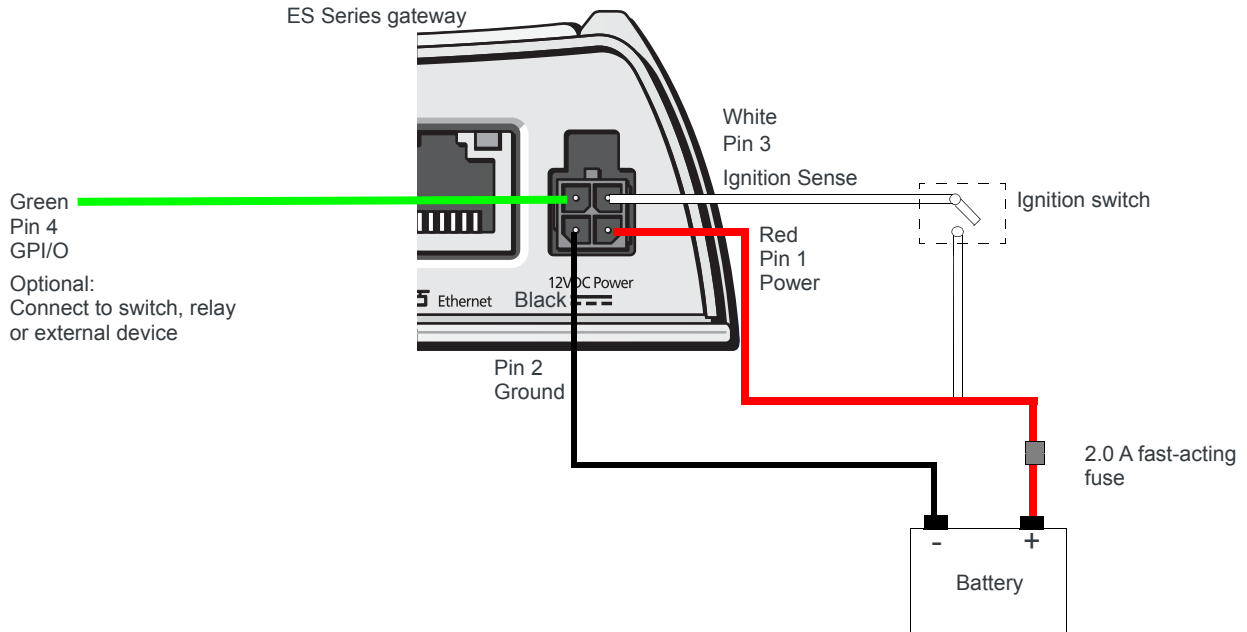

Figure 3-3: DC power cable connections (Colors indicate DC cable wire colors.)

Table 3-2: Power Connector Pin and DC cable Wires

Pin	Name	Associated DC Cable Wire Color	Description	Type
1	Power	Red	Main power supply for device	PWR
2	GND	Black	Main device ground	PWR
3	IGN Sense	White	Ignition Sense: Connected to the vehicle ignition or an external switch, for example on a low voltage shutdown. When the ES gateway is connected to a low voltage monitor, the ES gateway is off when this pin is either open-circuit or grounded, and on when this pin is connected to power.	I
4	GPIO	Green	User configurable digital input/output or analog voltage sensing input. Connect to switch, relay or external device. Maximum rating is 30 V, 150 mA. For more information, see <a href="#">Pin 4 (General Purpose I/O)</a> on page 37 and the ALEOS Software Configuration User Guide.	I/O

### Pin 4 (General Purpose I/O)

This pin is a digital input/output (green wire on DC cable).

Pin 4 either:

- Monitors digital inputs and outputs
- Drives a relay

It has a maximum rating of 30 V and 50 mA sink current. The pin is user programmed. For information on configuring Pin 4 (Digital Input/Relay Output 1 in ACEmanager) refer to the ALEOS Software Configuration User Guide.

One way to use pin 4 is with events reporting. In ACEmanager you:

**1. Create an Event.**

This triggers the device to act when it sees a specific input. For example, you can tell the device to do something when the Pin 4 state (Digital Input/Relay Output 1 in ACEmanager) changes. This could be when a door is opened, activating a switch attached to it.

**2. Specify an Action.**

These are instructions the device performs when it sees an event. For example, an email could be sent to security, saying the door is open, giving the time, location and other information.

**3. Link the event to the action.**

For more information on configuring event reporting, refer to the ALEOS Software Configuration User Guide.

There are several typical uses for Pin 4:

- As a digital input, it monitors a switch, using its opening or closing to record events or monitoring external voltages of up to 30 VDC. For example, you could use it to measure the voltage on a 24 VDC light bulb and have the device react when it turns on.

When the switch, or input voltage is:

- Open (2.2 VDC to 30 VDC) – It is read as a digital input=1
- Closed (0 to 1.2 VDC) – It is read as a digital input=0

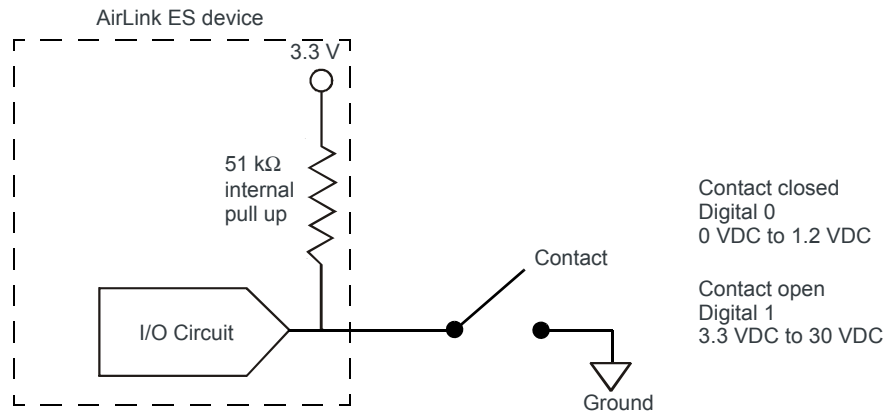

Examples: Door opening/closing, valve opening/closing, ignition on/off, tow bar up/down, empty/full container.

Figure 3-4: Digital Input Operation

- As a digital output, it can trigger an alarm, a siren, or a door lock, or open a valve or switch. Pin 4 is an open collector transistor output normally at 3.3 VDC. When triggered, it is pulled to low.

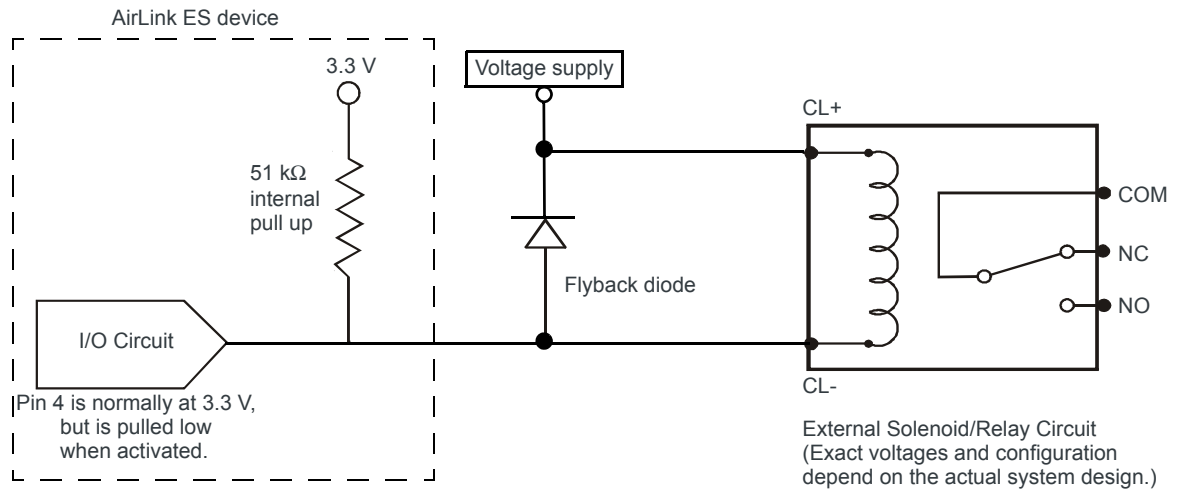

Figure 3-5: Digital Output Operation

*Note: Some solenoids/relays include a flyback diode built into the unit. For those that do not, Sierra Wireless recommends a flyback diode with a voltage rating at least double the relay voltage and a current rating at least double the relay ON current to avoid damage to the ES input. A common 1N4007 will work for most applications.*

The initial state of the digital output when the device is rebooted is configurable in ACEmanager.

## Local Management

When the Ethernet port is connected to the enterprise router, ACEmanager requires a USB connection to a management PC and ALEOS must be configured to support virtual Ethernet over the USB interface.

AT Commands can also be executed locally if the USB interface is configured as a virtual serial connection.

## Remote Management

Once power is applied and the configuration template is set up, the ES Series device can be remotely managed using one of three methods:

- ACEmanager—OTA connections to the device (One on one management)  
Refer to the ALEOS Software Configuration User Guide.
- AirLink Management Service—One to many management service  
Refer to [www.sierrawireless.com/ALMS](http://www.sierrawireless.com/ALMS)
- SNMP—SNMP trap reporting and MIB tree parsing  
Refer to the ALEOS Software Configuration User Guide for more information or go to [source.sierrawireless.com](http://source.sierrawireless.com) for a soft copy.





## 4: AirLink ES Series Specifications

### Radio Frequency Bands by Product<sup>1</sup>

Table 4-1: ES450 International—MC7304

Radio Technology	SKU		Band	Frequency
	Generic	Telstra		
LTE	✓	✓	Band 1 (2100 MHz)	Tx: 1920–1980 MHz Rx: 2110–2170 MHz
	✓	✓	Band 3 (1800 MHz)	Tx: 1710–1785 MHz Rx: 1805–1880 MHz
	✓	✓	Band 7 (2600 MHz)	Tx: 2500–2570 MHz Rx: 2620–2690 MHz
	✓	✓	Band 8 (900 MHz)	Tx: 800–915 MHz Rx: 925–960 MHz
	✓	✓	Band 20 (800 MHz)	Tx: 832–862 MHz Rx: 791–821 MHz
HSPA	✓	✓	Band 1 (2100 MHz)	Tx: 1920–1980 MHz Rx: 2110–2170 MHz
	✓	✓	Band 2 (1900 MHz)	Tx: 1850–1910 MHz Rx: 1930–1990 MHz
	✓	✓	Band 5 (850 MHz)	Tx: 824–849 MHz Rx: 869–894 MHz
	✓	✓	Band 8 (900 MHz)	Tx: 880–915 MHz Rx: 925–960 MHz
EDGE	✓	✓	GSM 850 (850 MHz)	Tx: 824–849 MHz Rx: 869–894 MHz
	✓	✓	GSM 900 (900 MHz)	Tx: 880–915 MHz Rx: 925–960 MHz
	✓	✓	DCS 1800 (1800 MHz)	Tx: 1710–1785 MHz Rx: 1805–1880 MHz
	✓	✓	PCS1900 (1900 MHz)	Tx: 1850–1910 MHz Rx: 1930–1990 MHz

1. You can view the Radio Module Type in ACEmanager (Status > About).

Table 4-2: ES450 North America—MC7354

Radio Technology	SKU				Band	Frequency
	Generic	Verizon Wireless	AT&T	Sprint		
LTE	✓		✓		Band 2 (1900 MHz)	Tx: 1850–1910 MHz Rx: 1930–1990 MHz
	✓	✓	✓		Band 4 (AWS) (1700 / 2100 MHz)	Tx: 1710–1755 MHz Rx: 2110–2155 MHz
	✓		✓		Band 5 (850 MHz)	Tx: 824–849 MHz Rx: 869–894 MHz
	✓	✓			Band 13 (700 MHz)	Tx: 777–787 MHz Rx: 746–756 MHz
	✓		✓		Band 17 (700 MHz)	Tx: 704–716 MHz Rx: 734–746 MHz
	✓			✓	Band 25 (1900 MHz Block G)	Tx: 1850–1915 MHz Rx: 1930–1995 MHz
CDMA / EV-DO	✓	✓		✓	BC0 (Cellular 800 MHz)	Tx: 824–849 MHz Rx: 869–894 MHz
	✓	✓		✓	BC1 (PCS 1900 MHz)	Tx: 1850–1910 MHz Rx: 1930–1990 MHz
	✓			✓	BC10 (Secondary 800 MHz)	Tx: 817–824 MHz Rx: 861–869 MHz
HSPA	✓	✓	✓	✓	Band 1 (2100 MHz)	Tx: 1920–1980 MHz Rx: 2110–2170 MHz
	✓	✓	✓	✓	Band 2 (1900 MHz)	Tx: 1850–1910 MHz Rx: 1930–1990 MHz
	✓				Band 4 (AWS 1700 / 2100 MHz)	Tx: 1710–1755 MHz Rx: 2110–2155 MHz
	✓	✓	✓	✓	Band 5 (850 MHz)	Tx: 824–849 MHz Rx: 869–894 MHz
	✓	✓	✓	✓	Band 8 (900 MHz)	Tx: 880–915 MHz Rx: 925–960 MHz

Table 4-2: ES450 North America—MC7354 (Continued)

Radio Technology	SKU				Band	Frequency
	Generic	Verizon Wireless	AT&T	Sprint		
EDGE	✓	✓	✓	✓	GSM 850 (850 MHz)	Tx: 824–849 MHz Rx: 869–894 MHz
	✓	✓	✓	✓	GSM 900 (900 MHz)	Tx: 880–915 MHz Rx: 925–960 MHz
	✓	✓	✓	✓	DCS 1800 (1800 MHz)	Tx: 1710–1785 MHz Rx: 1805–1880 MHz
	✓	✓	✓	✓	PCS1900 (1900 MHz)	Tx: 1850–1910 MHz Rx: 1930–1990 MHz

Table 4-3: ES440 Verizon Wireless—MC7750

Radio Technology	Band	Frequencies
LTE	Band 13 (700 MHz)	Tx: 777–787 MHz Rx: 746–756 MHz
CDMA/EV-DO	BC0 (Cellular) (800 MHz)	Tx: 824–849 MHz Rx: 869–894 MHz
	BC1 (PCS) (1900 MHz)	Tx: 1850–1910 MHz Rx: 1930–1990 MHz

Table 4-4: ES440 AT&amp;T and Canada—MC7700

Radio Technology	Band	Frequency
LTE	Band 1 (2100)	Tx: 1920–1980 MHz Rx: 2110–2170 MHz
	Band 4 (AWS) 1700/2100 MHz	Tx: 1710–1755 MHz Rx: 2110–2155 MHz
	Band 17 (700 MHz)	Tx: 704–716 MHz Rx: 734–746 MHz
HSPA	Band 1 (2100 MHz)	Tx: 1920–1980 MHz Rx: 2110–2170 MHz
	Band 2 (1900 MHz)	Tx: 1850–1910 MHz Rx: 1930–1990 MHz
	Band 5 (850 MHz)	Tx: 824–849 MHz Rx: 869–894 MHz
	Band 6 (800 MHz)	Tx: 830–840 MHz Rx: 875–885 MHz

**Table 4-4: ES440 AT&T and Canada—MC7700 (Continued)**

Radio Technology	Band	Frequency
<b>EDGE</b>	GSM 850 (850 MHz)	Tx: 824–849 MHz Rx: 869–894 MHz
	EGSM 900 (900 MHz)	Tx: 880–915 MHz Rx: 925–960 MHz
	DCS1800 (1800 MHz)	Tx: 1710–1785 MHz Rx: 1805–1880 MHz
	PCS 1900 (1900 MHz)	Tx: 1850–1910 MHz Rx: 1930–1990 MHz

**Table 4-5: ES440 International—MC7710**

Radio Technology	Band	Frequency
<b>LTE</b>	Band 1 (2100 MHz)	Tx: 1920–1980 MHz Rx: 2110–2170 MHz
	Band 3 (1800 MHz)	Tx: 1710–1785 MHz Rx: 1805–1880 MHz
	Band 7 (2600 MHz)	Tx: 2500–2570 MHz Rx: 2620–2690 MHz
	Band 8 (900 MHz)	Tx: 880–915 MHz Rx: 925–960 MHz
	Band 20 (DD 800 MHz)	Tx: 832–862 MHz Rx: 791–821 MHz
<b>HSPA</b>	Band 1 (2100 MHz)	Tx: 1920–1980 MHz Rx: 2110–2170 MHz
	Band 8 (900 MHz)	Tx: 880–915 MHz Rx: 925–960 MHz
<b>EDGE</b>	GSM 900 (900 MHz)	Tx: 880–915 MHz Rx: 925–960 MHz
	DCS 1800 (1800 MHz)	Tx: 1710–1785 MHz Rx: 1805–1880 MHz
	PCS1900 (1900 MHz)	Tx: 1850–1910 MHz Rx: 1930–1990 MHz

## Radio Module Conducted Transmit Power

The following tables provide radio module conducted transmit power specifications. The radio module type is printed on the label on the bottom of the gateway and is available in ACEmanager (Status > About).

### AirLink ES450

**Table 4-6: ES450 North America—MC7354 Conducted Transmit Power**

Band	Conducted Tx Power (dBm)	Notes
<b>LTE</b>		
Band 1 Band 4 Band 13 Band 17 Band 25	+23±1	
<b>UMTS</b>		
Band 1 (IMT 2100 12.2 kbps) Band 2 (UMTS 1900 12.2 kbps) Band 4 (AWS 1700/2100 12.2 kbps) Band 5 (UMTS 850 12.2 kbps) Band 8 (UMTS 900 12.2 kbps)	+23±1	Connectorized (Class 3)
<b>GSM / EDGE</b>		
GSM 850 CS GSM 900 CS	+32±1	GMSK mode, connectorized (Class 4)
	+27±1	8 PSK mode, connectorized (Class E2)
DCS 1800 CS PCS 1900 CS	+29±1	GMSK mode, connectorized (Class 4)
	+26±1	8 PSK mode, connectorized (Class E2)
<b>CDMA</b>		
Band Class 0 (Cellular)	+24+0.5/-1	
Band Class 1 (PCS)		
Band Class 10 (Cellular)		

**Table 4-7: ES450 International—MC7304 Conducted Transmit Power**

Band	Conducted Tx Power (dBm)	Notes
<b>LTE</b>		
Band 1 Band 3 Band 8 Band 20	+23±1	
Band 7	+22±1	
<b>UMTS</b>		
Band 1 (IMT 2100 12.2 kbps) Band 2 (UMTS 1900 12.2 kbps) Band 5 (UMTS 850 12.2 kbps) Band 6 (UMTS 800 12.2 kbps) Band 8 (UMTS 900 12.2 kbps)	+23±1	Connectorized (Class 3)
<b>GSM / EDGE</b>		
GSM 850 CS GSM 900 CS	+32±1	GMSK mode, connectorized (Class 4)
	+27±1	8 PSK mode, connectorized (Class E2)
DCS 1800 CS PCS 1900 CS	+29±1	GMSK mode, connectorized (Class 4)
	+26±1	8 PSK mode, connectorized (Class E2)

## AirLink ES440

**Table 4-8: ES440 Verizon Wireless—MC7750 Conducted Transmit Power**

Band	Average Conducted Tx Power (dBm)
<b>LTE</b>	
Band 13	+23±1
<b>CDMA</b>	
CDMA Band Class 0 (Cellular)	+23.5±1 (channel 1175) +24±1 (other channels)

**Table 4-9: ES440 AT&T and Canada—MC7700 Conducted Transmit Power**

Band	Conducted Tx Power (dBm)	Notes
<b>LTE</b>		
Band 1	+22±1	
Band 4 Band 17	+23±1	
<b>UMTS</b>		
Band 1 (IMT 2100 12.2 kbps) Band 2 (UMTS 1900 12.2 kbps) Band 5 (UMTS 860 12.2 kbps) Band 6 (UMTS 800 12.2 kbps)	+23±1	Connectorized (Class 3)
Band 1 (IMT 2100 MHz) 12.2 kbps	+23±1	Connectorized (Class 3)
<b>GSM / EDGE</b>		
GSM 850 CS GSM 900 CS	+32±1	GMSK mode, connectorized (Class 4)
	+27±1	8 PSK mode, connectorized (Class E2)
DCS 1800 CS PCS 1900 CS	+29±1	GMSK mode, connectorized (Class 4)
	+26±1	8 PSK mode, connectorized (Class E2)

**Table 4-10: ES440 International—MC7710 Conducted Transmit Power**

Band	Conducted Tx Power (dBm)	Notes
<b>LTE</b>		
Band 1 Band 3 Band 7 Band 8	+22±1	
Band 20	+23±1	
<b>UMTS</b>		
Band 1 (IMT 2100 12.2 kbps) Band 8 (UMTS 900 12.2 kbps)	+23±1	Connectorized (Class 3)

**Table 4-10: ES440 International—MC7710 Conducted Transmit Power**

Band	Conducted Tx Power (dBm)	Notes
<b>GSM / EDGE</b>		
GSM 900 CS	+32±1	GMSK mode, connectorized (Class 4)
	+27±1	8 PSK mode, connectorized (Class E2)
DCS 1800 CS PCS 1900 CS	+29±1	GMSK mode, connectorized (Class 4)
	+26±1	8 PSK mode, connectorized (Class E2)

## Host Interfaces

- 10/100 Base-T RJ-45 Ethernet
- RS-232 Serial port (DCE, requires null modem for console connection)
- USB V2.0 Micro-B connector
- 2 SMA antenna connectors (Primary, Secondary)
- Active antenna support

## Protocols

- Network: TCP/IP, UDP/IP, DNS
- Routing: NAT, Host Port Routing, DHCP, PPPoE, VLAN, VRRP, Reliable Static Route
- Applications: Telnet/SSH, Reverse Telnet, SMTP, SNMP, SNTTP

## Environmental

- Operating temperature: -20°C to +60°C (-4°F to +140°F)
- Storage temperature: -30°C to +70°C (-22°F to +158°F)
- Humidity: Maximum 95% RH @ 60°C (140°F)

**Table 4-11: Operational/Non-Operational Environmental Specifications**

Category	Op/Non-op	Reference
<b>Drop</b>	Non-operational	MIL-STD-810F, Method 516.5D
<b>Electrostatic Discharge</b>	Operational	IEC 61000-4-2
<b>Surface Abrasion</b>	Non-operational	IEC 60068-2-70 Part 2, Test Xb
<b>Relative Humidity</b>	Non-operational	MIL-STD-810F, 507.4

**Table 4-11: Operational/Non-Operational Environmental Specifications**

Category	Op/Non-op	Reference
IP Rating	Non-operational	IEC 60529 – IP20
Cargo Vibration	Non-operational	ISTA 2A 2001, test categories 1, 4, 5, & 6

**Table 4-12: Environmental Specifications**

Document Name	Specification
Free Fall Test	IEC 60068-2-2
Low Storage Temperature	IEC 60068-2-1
Thermal Shock	MIL-STD-810, Method 501.4, 502.4

## Industry Certifications

- FCC, IC, PTCRB
- CE, ACMA RCM, GCF, R&TTE
- CB Scheme, UL 60950
- ISO 7637-2
- RoHS, REACH, WEEE

## Power

- Voltage range: 9–36 VDC

## Power Consumption

- 100–240 VAC, 50/60 Hz, 500 mA
- Adapters for North and South America, Great Britain, Europe, Australia and New Zealand

## Dimensions and Weight

- 142 mm x 98.3 mm x 40.5 mm  
(5.6 in. x 3.8 in. x 1.6 in.)
- 397 g (14 oz.)

## SIM Card holder

- The SIM socket is a 6-pin socket operated at 1.8 V/3.3 V.
- This interface is compliant with the applicable 3GPP standards for USIM.

## Construction Materials

The ES Series case is die cast using aluminum alloy A380, which is powder coated.

## Reliability

The ES Series gateways have an MTBF of approximately 9.5 years.

## RoHS

The ES440 and ES450 comply with the Restriction of Hazardous Substances Directive (RoHS). This directive restricts the use of six hazardous materials in the manufacture of various types of electronic and electrical equipment.

## Device Management

- AirLink Management Service cloud-based device management application  
For more information, go to [www.sierrawireless.com/ALMS](http://www.sierrawireless.com/ALMS).
- ACEManager  
For more information, refer to the ALEOS Software Configuration User Guide.
- AT Commands  
For more information, refer to the ALEOS Software Configuration User Guide.

## Custom Applications

Use ALEOS Application Framework (AAF) to develop your own applications to run on ES Series devices and leverage the AirVantage M2M Cloud platform.

- Lua language coding platform
- Remote application management
- Eclipse-based IDE
- Integrated real-time debugging

## VPN/Security

- IPsec, SSL, and GRE VPN client
- Up to 5 VPN tunnels
- IKE encryption
- Port forwarding and DMZ
- Port filtering
- Trusted IP
- MAC address filtering

## Authentication

- LDAP
- RADIUS
- TACACS+

## Events Reporting

- Event Types: digital input, GPS/AVL, network parameters, data usage, timer, power, device temperature
- Report types: SMS, email, SNMP trap, relay output, GPS RAP reports, Events Protocol Message to Server

## Mechanical Specifications

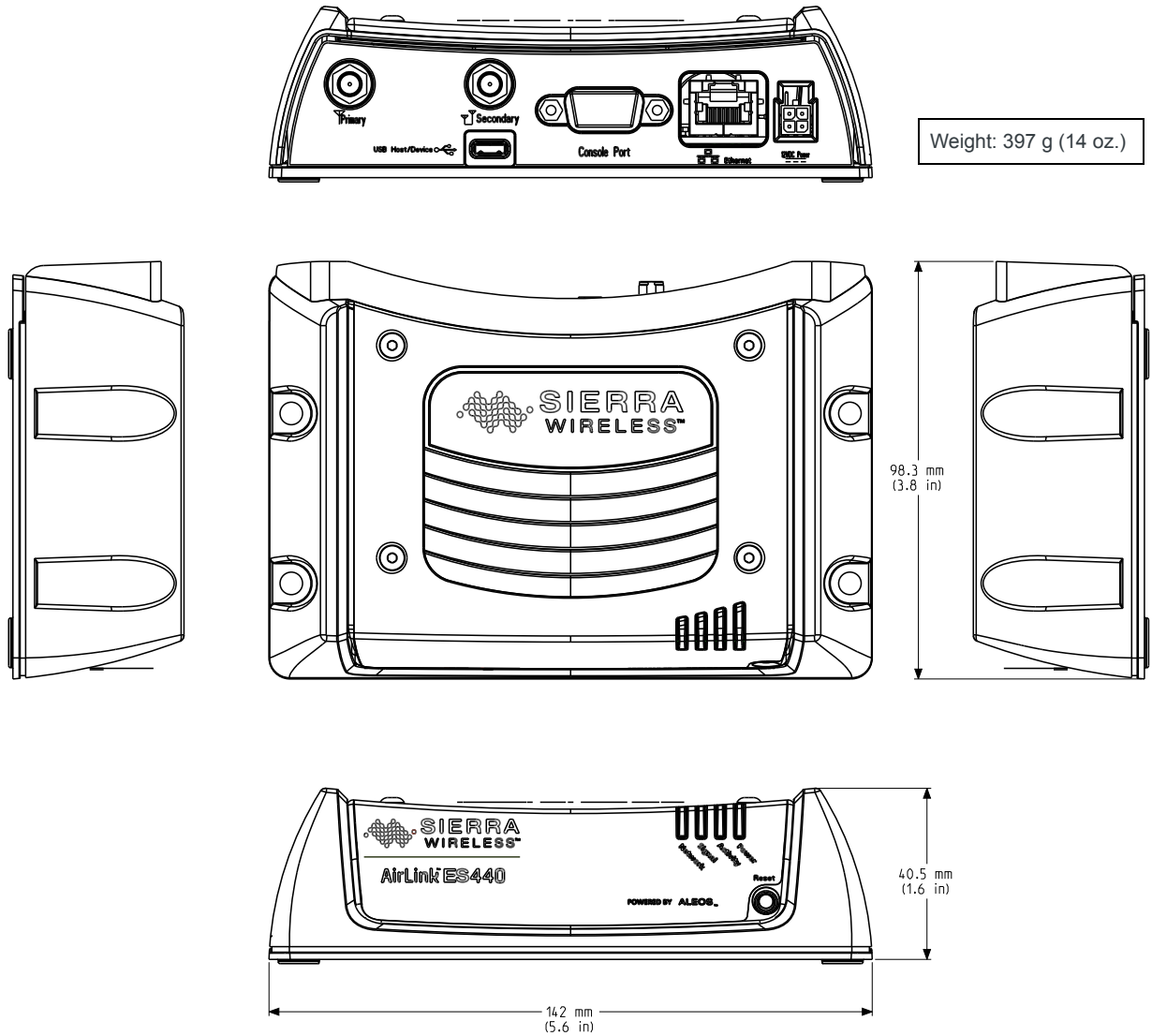

Figure 4-1: AirLink ES440 and ES450 Mechanical Specifications

## Antenna Specifications

The specifications for the antennas supplied with the ES Series gateway are described in [Table 4-13](#).

**Table 4-13: Main Antenna and RX/Diversity Antenna Specifications**

Parameter	Min	Typical	Max	Units	Notes
Impedance	—	50	—	$\Omega$	Antenna load impedance
VSWR <sup>a</sup>	—	—	2.5:1	—	Maximum allowed VSWR of antenna

a. Voltage Standing Wave Ratio

## 5: Regulatory Information

### Federal Communications Commission Notice (FCC United States)

This equipment has been tested and found to comply with the limits for a Class A digital device, pursuant to part 15 of the FCC Rules. These limits are designed to provide reasonable protection against harmful interference when the equipment is operated in a commercial environment.

This equipment generates, uses, and can radiate radio frequency energy and, if not installed and used in accordance with the instruction manual, may cause harmful interference to radio communications. Operation of this equipment in a residential area is likely to cause harmful interference in which case the user will be required to correct the interference at his own expense.

---

**Warning:** *Changes or modifications to this device not expressly approved by Sierra Wireless could void the user's authority to operate this equipment.*

---

### Important Information for North American Users on Radiation Exposure

This equipment complies with FCC/IC radiation exposure limits set forth for an uncontrolled environment. This equipment should be installed and operated with a minimum distance of 20 cm between the radiator and the user's body.

---

**Warning:** *This product is only to be installed by qualified personnel.*

---

---

**Warning:** *A minimum separation distance of 20 cm must be maintained between the antenna(s) used for this transmitter and all personnel.*

---

### Informations Importantes Pour les Utilisateurs Nord-Américains sur L'exposition aux Radiations

Ce matériel est conforme aux limites établies par FCC/IC en matière d'exposition aux radiofréquences dans un environnement non contrôlé. Ce matériel doit être installé et utilisé à une distance d'au moins 20 cm entre l'antenne et le corps de l'utilisateur.

---

**Avertissement :** *Ce produit est uniquement être installé par du personnel qualifié.*

---

**Avertissement :** *Une distance minimale de 20 cm doit être maintenue entre l'antenne (s) utilisées pour cet émetteur et l'ensemble du personnel.*

---

## Europe Generic Devices

Sierra Wireless hereby declares the AirLink ES440 and ES450 conform to all the essential requirements of Directive 1999/5/EC.

These products display the CE mark.



---

**Warning:** *This product is only to be installed by qualified personnel.*

---

**Warning:** *Changes or modifications to this device not expressly approved by Sierra Wireless could void the user's authority to operate this equipment.*

---

**Warning:** *A minimum separation distance of 20 cm must be maintained between the antenna(s) used for this transmitter and all personnel.*

---

The Declaration of Conformity made under Directive 1999/5/EC is available for viewing at: [source.sierrawireless.com](http://source.sierrawireless.com).

# ➤➤ | A: Accessories

## DC Power Cable (Black Connector)

**Table A-1: DC Power Cable**

DC Power Cable	
Part Number	2000522
Product Release	2016

### Components:

- ① 1 UL2464 20 AWG x 4 core cable
- ② 4 Molex female crimp terminals /AWG 20-24, 250V, 4A Max, phosphor bronze tin-plated (part number 43030-0001)
- ③ 1 Molex male 2x2P Ph: 3.0 mm housing, 250V, 5 A max, PA65 black UL94V-O (part number 43025-0408)

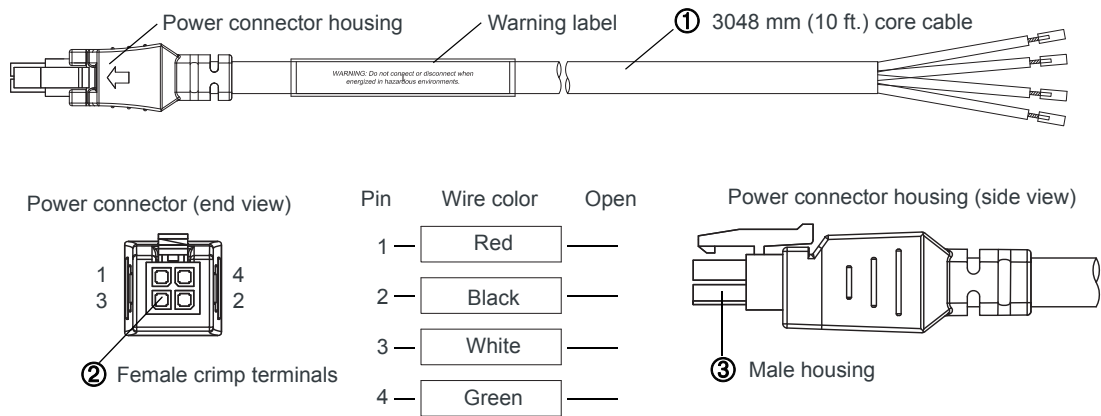

Figure A-1: DC Cable Specifications

## AC Power Adapter (Black Connector)

AC Power Adapter	
Part Number	2000579
Product Release Date	2016

## AC Power Adapter Input

**Table A-2: Input Specifications**

	Minimum	Typical	Maximum
<b>Input</b>			
Input Voltage	90 VAC	100–240 VAC	264 VAC
Input Frequency	47 Hz	50/60 Hz	63 Hz
<p><i>Note: Input voltage range is 90 VAC to 264 VAC.                      Maximum input current is 500 mA at 100–240 VAC.                      Inrush current will not exceed 75 A at 100–240 VAC input and maximum load from a cold start at 25°C.</i></p>			

## AC Power Adapter Output

**Table A-3: AC Power Adapter Output Specifications**

	Minimum	Typical	Maximum	Test conditions
Output Voltage	11.4 VDC	12.0 VDC	12.6 VDC	0 ~ 1.5 A loading

# AC Power Adapter Environmental Specifications

**Table A-4: AC Power Adapter Environmental Specifications**

<b>Operating</b>	
Operating Temperature	0°C ~ 40°C (operates normally)
Relative Humidity	10% ~ 90%
Altitude	Sea level to 2,000 meters
Vibration	1.0 mm, 10–55 Hz, 15 minutes per cycle for each axis (X, Y, Z)
<b>Non-operating</b>	
Storage Temperature	-30°C ~ 70°C
Relative Humidity	10% ~ 90%
Vibration and Shock	MIL-STD-810D, method 514

## AC Power Adapter Reliability and Quality Control

### AC Power Adapter MTBF

When the power supply is operating within the limits of this specification, the MTBF is at least 200,000 hours at 25°C (MIL-HDBK-217F).

---

*Note: For router MTBF, see [Reliability](#) on page 50.*

---

## AC Power Adapter Safety Standards

The power supply is certified with the following international regulatory standards:

<b>Regulatory Agency</b>	<b>Country or Region</b>	<b>Certified</b>	<b>Standard</b>
UL	USA	Approved	UL60950-1
GS	Europe	Approved	EN60950-1
CE	Europe	Approved	EN60950-1
SAA	Australia	Approved	AS/NZS 60950
CCC	China	Approved	GB4943
CUL	Canada	Approved	CSA C22.2 NO.60950-1

## AC Power Adapter EMC Standards

The power supply meets the radiated and conducted emission requirements for EN55022, FCC Part 15, Class B, GB9254.

## AC Power Adapter Hazardous Substances

- EU Directive 2011/65/EU “RoHS”
- EU Directive 2012/19/EU “WEEE”
- REACH

## AC Power Adapter Energy Efficiency

The AC adapter complies with International Efficiency Levels, as shown in [Table A-5](#).

**Table A-5: AC Adapter Energy Efficiency**

Supplied Input	No-load Power Consumption	Average Active Mode Efficiency	International Efficiency Level
115 VAC, 60 HZ.	Less than 0.1 W	Greater than 85%	VI
230 VAC, 50 Hz.	Less than 0.3 W	Greater than 80.4%	V

## »» B: Acronyms

# B

**Table B-1: Acronyms**

Acronym or Term	Definition
<b>1xEV-DO</b>	<p>Single Carrier (1X) EVolution—Data Only</p> <p>A high-speed standard for cellular packet data communications.</p> <p>It supports Internet connections with data rates up to 3.1 Mbps. (downlink from the network) and 1.8 Mbps (uplink to the network). Average data rates are roughly: for Rev. A: 600-1300 kbps. (downlink from the network) and 300-400 kbps (uplink to the network); for Rev. 0: 400-700 kbps (downlink from the network) and 40-80 kbps (uplink to the network). Actual speed depends on the network conditions. Compare to 1X.</p>
<b>1X</b>	<p>Single Carrier (1X) Radio Transmission Technology</p> <p>A high-speed standard for cellular packet data communications.</p> <p>It supports Internet connections with data rates up to 153 kbps (simultaneously in each direction—downlink and uplink). Actual speed depends on the network conditions. Compare to 1xEV-DO.</p>
<b>3GPP</b>	3 <sup>rd</sup> Generation Partnership Project
<b>AT</b>	A set of device commands, preceded by “AT” originally developed by Hayes, Inc. for their devices. The structure (but not the specific commands, which vary greatly from manufacturer to manufacturer) is a de facto device industry standard.
<b>CDMA</b>	<p>Code Division Multiple Access</p> <p>A wideband spread spectrum technique used in digital cellular, personal communications services, and other wireless networks. Wide channels (1.25 MHz) are obtained through spread spectrum transmissions, thus allowing many active users to share the same channel. Each user is assigned a unique digital code, which differentiates the individual conversations on the same channel.</p>
<b>cdmaOne</b>	The IS-95 CDMA standard developed by QUALCOMM Inc.
<b>DCE</b>	Data Communications Equipment
<b>EIA</b>	Electronics Industry Association
<b>EMC</b>	Electro Magnetic Compatibility
<b>EMI</b>	Electro Magnetic Interference

Table B-1: Acronyms (Continued)

Acronym or Term	Definition
<b>EU</b>	European Union Organization of European countries
<b>ERP</b>	Effective Radiated Power
<b>ESN</b>	Electronic Serial Number The unique first-generation serial number assigned to the LS300 for use on the wireless network. Compare to <a href="#">MEID</a> .
<b>FCC</b>	Federal Communications Commission The U.S. federal agency that is responsible for interstate and foreign communications. The FCC regulates commercial and private radio spectrum management, sets rates for communications services, determines standards for equipment, and controls broadcast licensing. Consult <a href="http://www.fcc.gov">www.fcc.gov</a> .
<b>FW</b>	Firmware Software stored in ROM or EEPROM; essential programs that remains even when the system is turned off. Firmware is easier to change than hardware but more permanent than software stored on disk.
<b>GPS</b>	Global Positioning System A system that uses a series of 24 satellites to provide navigational data.
<b>HSPA</b>	High Speed Packet Access  An amalgamation of two mobile telephony protocols: High Speed Downlink Packet Access (HSDPA) and High Speed Uplink Packet Access (HSUPA).  It extends and improves the performance of existing 3rd generation mobile telecommunication networks utilizing the WCDMA protocols.
<b>HSPA+</b>	Evolved HSPA (also called HSPA+) allows bit-rates to reach as high as 168 Mbit/s in the downlink and 22 Mbit/s in the uplink. An improved 3GPP standard.
<b>IEC</b>	International Electrotechnical Commission
<b>IOTA</b>	Internet Over The Air An automated feature, supported by some service providers, to perform account setup for you by making a connection to the CDMA network and using a secure Internet connection to download account parameters to your device.
<b>IS</b>	Interim Standard After receiving industry consensus, the <a href="#">T1A1A/EIA</a> forwards the standard to ANSI for approval.

**Table B-1: Acronyms (Continued)**

Acronym or Term	Definition
<b>kbps</b>	Kilobits per second Actually 1000, not 1024, as used in computer memory size measurements of kilobytes.
<b>LED</b>	Light Emitting Diode A semiconductor diode that emits visible or infrared light.
<b>LTE</b>	Long Term Evolution High performance air interface for cellular mobile communication systems.
<b>Mbps</b>	Millions of bits per second, or Megabits per second.
<b>MEID</b>	Mobile Equipment Identifier The unique second-generation serial number assigned to the device for use on the wireless network. Compare to <a href="#">ESN</a> .
<b>NV</b>	Non-Volatile (memory)
<b>OEM</b>	Original Equipment Manufacturer A company that manufactures a product and sells it to a reseller.
<b>PCS</b>	Personal Communications Services A cellular communication infrastructure that uses a different frequency range than Advanced Mobile Phone System (AMPS).
<b>PPP</b>	Point to Point Protocol. An alternative communications protocol used between computers, or between computers and routers on the Internet. PPP is an enhanced Serial Line Internet Protocol (SLIP).
<b>PRI</b>	Product Release Instructions A file containing the settings used to configure devices for a particular service provider, customer, or purpose.
<b>RF</b>	Radio Frequency
<b>RoHS</b>	Restriction of use of Hazardous substances. EU Directive 2002/95
<b>Rx</b>	Receive
<b>SKU</b>	Stock Keeping Unit Identifies an inventory item: a unique code, consisting of numbers or letters and numbers, assigned to a product by a retailer for purposes of identification and inventory control.

**Table B-1: Acronyms (Continued)**

<b>Acronym or Term</b>	<b>Definition</b>
<b>SMS</b>	Short Message Service A feature that allows users of a wireless device on a wireless network to receive or transmit short electronic alphanumeric messages (up to 160 characters, depending on the service provider).
<b>TIA/EIA</b>	Telecommunications Industry Association / Electronics Industry Association A standards setting trade organization, whose members provide communications and information technology products, systems, distribution services and professional services in the United States and around the world. Consult <a href="http://www.tiaonline.org">www.tiaonline.org</a> .
<b>Tx</b>	Transmit
<b>USB</b>	Universal Serial Bus

# »» Index

## A

- AC Power Adapter, [55](#)
- Acronyms, [59](#)
- ALEOS
  - default user name and password, [23](#)
  - description of, [13](#)
- ALMS, [14](#)
- Analog input voltage sensing
  - on power connector, [37](#)
- Antenna
  - auxiliary receive port, [12](#)
  - Diversity/AUX, [12](#)
  - maximum gain, [12](#)
  - receive and transmit port, [12](#)
  - Receive port, backup, [12](#)
  - safe mounting, [33](#)
  - separation, [34](#)
  - specifications, [52](#)
- AUX/Diversity antenna connector, [12](#)

## C

- Case, composition of, [49](#)
- Cloud computing with ALMS, [14](#)
- Communication
  - AirLink Management Service, [14](#)
  - command line prompt, using, [26](#)
  - Ethernet connector, [12](#)
  - virtual Ethernet/serial port via USB, [13](#)
- Configuring with
  - ACEmanager, [23](#)
  - AirLink Management Service, [25](#)
  - AT Commands, [26](#)

## D

- Default settings for device, reset to, [11](#)
- Diversity/AUX Antenna Connector, [12](#)

## E

- Ethernet
  - computer connection and log in, [23](#)
  - connector, [12](#)
- Ethernet connector, [12](#)

## G

- Glossary, [59](#)

## I

- Installing SIM card, [18](#)
- IP address, obtaining with command line prompt, [26](#)

## L

- LED
  - also see specific LED, [11](#)
  - description of LED, [26](#)

## M

- Measuring external voltages, [37](#)

## P

- Pinging device with command line prompt, [26](#)
- Power connector, measuring external voltages, [37](#)

## R

- Receive port, backup, [12](#)
- Regulatory specifications, [58](#)
- Reset button, [11](#)
- RoHS compliance, [50](#)
- RS-232 port on rear panel, [12](#)

## S

- Serial port (RS-232), [12](#)
- SIM card, installing, [18](#)
- Standards, regulatory, [58](#)

## U

- USB port on front panel, [12](#)

## V

- Virtual Ethernet port, [13](#)
- Voltage monitoring battery or power input, [37](#)





