



# AirPrime XA1100 and XM1100

## Development Kit User Guide



**SIERRA**  
WIRELESS®

41111189  
Rev 2.4

## Important Notice

Due to the nature of wireless communications, transmission and reception of data can never be guaranteed. Data may be delayed, corrupted (i.e., have errors) or be totally lost. Although significant delays or losses of data are rare when wireless devices such as the Sierra Wireless modem are used in a normal manner with a well-constructed network, the Sierra Wireless modem should not be used in situations where failure to transmit or receive data could result in damage of any kind to the user or any other party, including but not limited to personal injury, death, or loss of property. Sierra Wireless accepts no responsibility for damages of any kind resulting from delays or errors in data transmitted or received using the Sierra Wireless modem, or for failure of the Sierra Wireless modem to transmit or receive such data.

## Safety and Hazards

Do not operate the Sierra Wireless modem in areas where blasting is in progress, where explosive atmospheres may be present, near medical equipment, near life support equipment, or any equipment which may be susceptible to any form of radio interference. In such areas, the Sierra Wireless modem **MUST BE POWERED OFF**. The Sierra Wireless modem can transmit signals that could interfere with this equipment.

Do not operate the Sierra Wireless modem in any aircraft, whether the aircraft is on the ground or in flight. In aircraft, the Sierra Wireless modem **MUST BE POWERED OFF**. When operating, the Sierra Wireless modem can transmit signals that could interfere with various onboard systems.

---

*Note: Some airlines may permit the use of cellular phones while the aircraft is on the ground and the door is open. Sierra Wireless modems may be used at this time.*

---

The driver or operator of any vehicle should not operate the Sierra Wireless modem while in control of a vehicle. Doing so will detract from the driver or operator's control and operation of that vehicle. In some states and provinces, operating such communications devices while in control of a vehicle is an offence.

## Limitation of Liability

The information in this manual is subject to change without notice and does not represent a commitment on the part of Sierra Wireless. SIERRA WIRELESS AND ITS AFFILIATES SPECIFICALLY DISCLAIM LIABILITY FOR ANY AND ALL DIRECT, INDIRECT, SPECIAL, GENERAL, INCIDENTAL, CONSEQUENTIAL, PUNITIVE OR EXEMPLARY DAMAGES INCLUDING, BUT NOT LIMITED TO, LOSS OF PROFITS OR REVENUE OR ANTICIPATED PROFITS OR REVENUE ARISING OUT OF THE USE OR INABILITY TO USE ANY SIERRA WIRELESS PRODUCT, EVEN IF SIERRA WIRELESS AND/OR ITS AFFILIATES HAS BEEN ADVISED OF THE POSSIBILITY OF SUCH DAMAGES OR THEY ARE FORESEEABLE OR FOR CLAIMS BY ANY THIRD PARTY.

Notwithstanding the foregoing, in no event shall Sierra Wireless and/or its affiliates aggregate liability arising under or in connection with the Sierra Wireless product, regardless of the number of events, occurrences, or claims giving rise to liability, be in excess of the price paid by the purchaser for the Sierra Wireless product.

## Patents

This product may contain technology developed by or for Sierra Wireless Inc. This product includes technology licensed from QUALCOMM®. This product is manufactured or sold by Sierra Wireless Inc. or its affiliates under one or more patents licensed from MMP Portfolio Licensing.

## Copyright

© 2018 Sierra Wireless. All rights reserved.

## Trademarks

Sierra Wireless®, AirPrime®, AirLink®, AirVantage® and the Sierra Wireless logo are registered trademarks of Sierra Wireless.

Windows® and Windows Vista® are registered trademarks of Microsoft Corporation.

Macintosh® and Mac OS X® are registered trademarks of Apple Inc., registered in the U.S. and other countries.

QUALCOMM® is a registered trademark of QUALCOMM Incorporated. Used under license.

Other trademarks are the property of their respective owners.

## Contact Information

Sales information and technical support, including warranty and returns	Web: <a href="http://sierrawireless.com/company/contact-us/">sierrawireless.com/company/contact-us/</a> Global toll-free number: 1-877-687-7795 6:00 am to 5:00 pm PST
Corporate and product information	Web: <a href="http://sierrawireless.com">sierrawireless.com</a>

## Revision History

Revision number	Release date	Changes
1	June 23, 2017	Initial revision in SWI Template
2.0	April 2018	Changed all instances of EVK to Development Kit
2.1	May 04, 2018	Updated <a href="#">System Requirements</a> on page 14
2.2	May 09, 2018	Updated <a href="#">USB Driver and GNSS Tool</a> on page 14
2.3	May 16, 2018	Updated <a href="#">System Requirements</a> on page 14
2.4	May 28, 2018	Updated <a href="#">USB Driver and GNSS Tool</a> on page 14

# Contents

<b>Introduction</b> .....	<b>7</b>
Caution .....	8
Packing Contents .....	8
<b>Function Description</b> .....	<b>9</b>
<b>Function Testing</b> .....	<b>12</b>
Preparation for Power and Data Communication (not using 3D-Fix function)	12
Application for Various RF Reception .....	13
<b>Software Usage</b> .....	<b>14</b>
System Requirements .....	14
USB Driver and GNSS Tool .....	14
Installing the USB Driver .....	14
Using GNSS Tool .....	16
<b>RTCM Hardware Settings</b> .....	<b>18</b>
Getting RTCM Data via RS232 Port .....	18
<b>RTCM Software Settings</b> .....	<b>19</b>
<b>Troubleshooting</b> .....	<b>21</b>
Setup Troubleshooting .....	21
Causes of Poor GPS Signals .....	22

## List of Figures

Figure 1-1: Left: lovry 2; Right: XA1100. . . . .	7
Figure 1-2: XM1100 . . . . .	7
Figure 2-1: Compatible Models (Series 1): lovry 2 . . . . .	9
Figure 2-2: Compatible Models (Series 1): XM1100 . . . . .	10
Figure 2-3: Compatible Models (Series 2): XA1100 . . . . .	11
Figure 3-1: Components . . . . .	12
Figure 3-2: Using an External Antenna . . . . .	13
Figure 3-3: Using an External Antenna . . . . .	13
Figure 4-1: Driver Installation Folder . . . . .	14
Figure 4-2: Starting the Installation Process . . . . .	15
Figure 4-3: Selecting Manage . . . . .	15
Figure 4-4: Accessing the Port Properties . . . . .	16
Figure 4-5: GNSS Tool Main Screen . . . . .	16
Figure 4-6: COM Port Dialog . . . . .	17
Figure 5-1: RS232 Connection . . . . .	18
Figure 6-1: Settings Menu . . . . .	19
Figure 6-2: NTrip Client Settings . . . . .	19
Figure 6-3: Clicking the RTCM button to enable the RTCM function. . . . .	20

## List of Tables

Table 7-1: Troubleshooting Causes and Solutions .....	21
Table 7-2: Examples where Poor GPS Signals may Occur .....	22

# >> 1: Introduction

The main purpose of the Development Kit is to simplify the evaluation process for GPS modules and to help testers operate our products with convenience and ease.

This device can communicate with computer devices via USB, and must be used in conjunction with the GNSS Tool software application. You can record all GPS module data such as satellites' status, time-to-first-fix (TTFF), date and time.

If you evaluate the RTCM function, it will show you how to run the GNSS Tool with the Development Kit via RS232 (DB-9 Connector).

The Development Kit is divided into two series, based on the various modules listed below.

Left: With External Antenna (series 1). Right: Built-in Switch Antenna input (series 2).

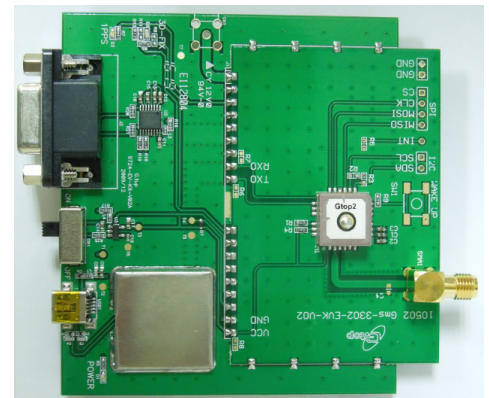
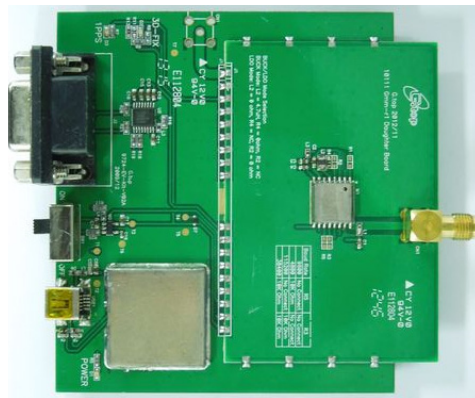

Figure 1-1: Left: lovry 2; Right: XA1100

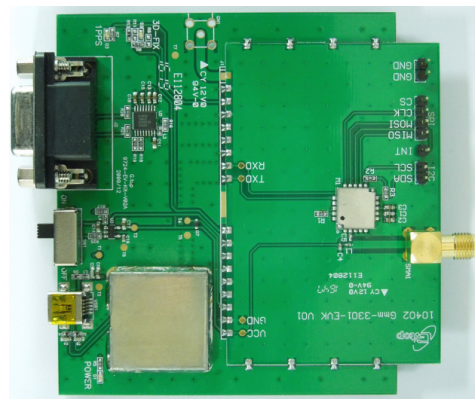

Figure 1-2: XM1100

## Caution

- Global position system (GPS) is the property of American Ministry of National Defense; they are fully responsible for the preciseness and maintenance of the system. Any changes they have implemented to the system in the future may enhance or deteriorate the effectiveness and performance of the received GPS data.
- The GPS signal might be cut-off or become seriously weakened if you operate the Development Kit inside any infrastructures such as buildings, tunnels, or nearby any huge objects and/or obstructions. The kit has not malfunctioned and will operate properly again once it receives clear GPS signals (works best under open sky).
- To avoid damaging the intricate electronic components and circuitry, please do not place the Development Kit directly under the sun for long periods of time.

## Packing Contents

- User Manual / Software Application Program
- CP210X USB Bridge VCP driver
- GNSS Tool with user manual
- Development Kit user manual

---

*Note: These items will be delivered by E-mail. Please contact your dealer for the items for more information.*

---

- USB Cable
- Development Kit with Main Board and GPS Module
- External Antenna

# >> 2: Function Description

The following figures illustrate and describe the Development Kit:

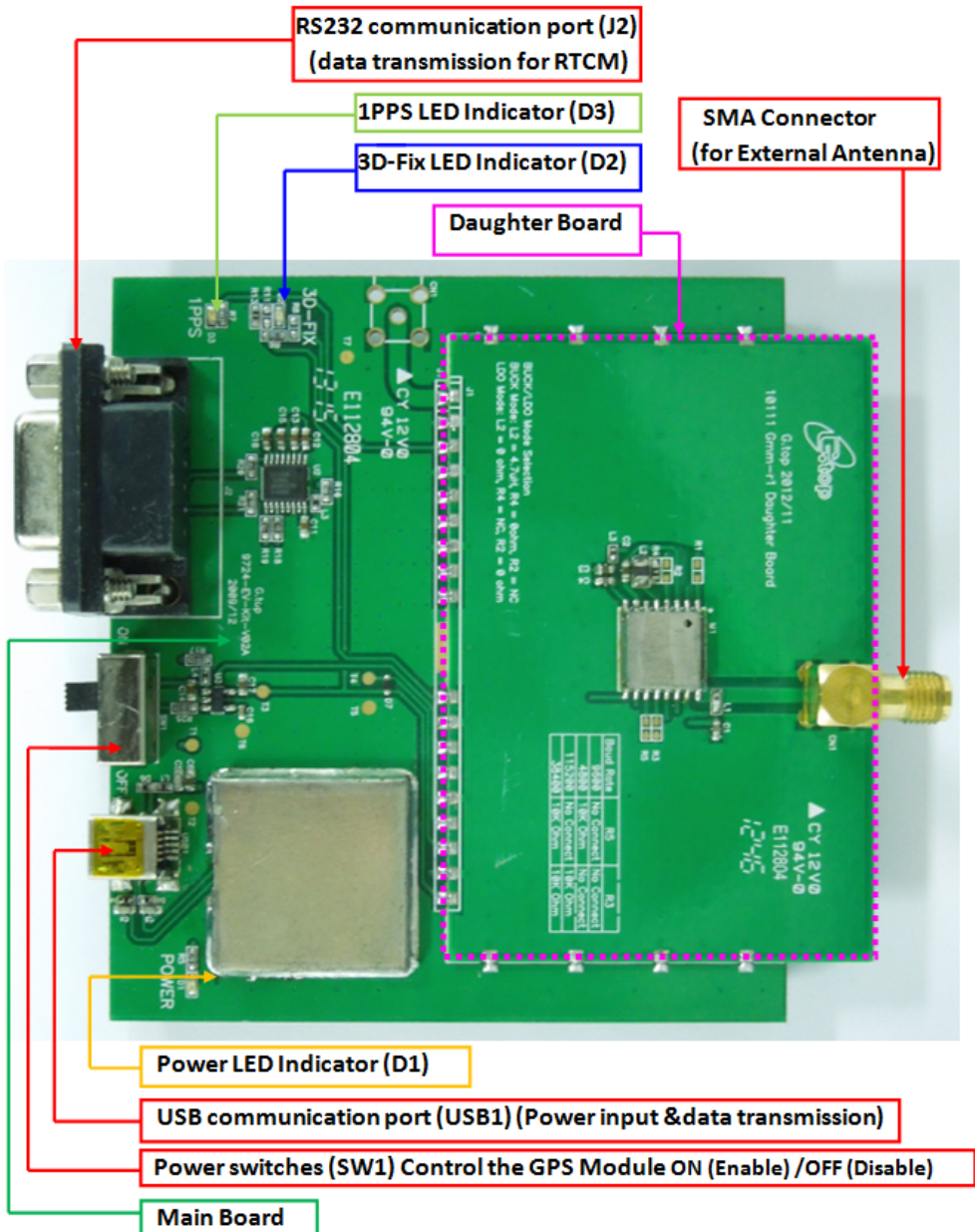

Figure 2-1: Compatible Models (Series 1): Iovry 2

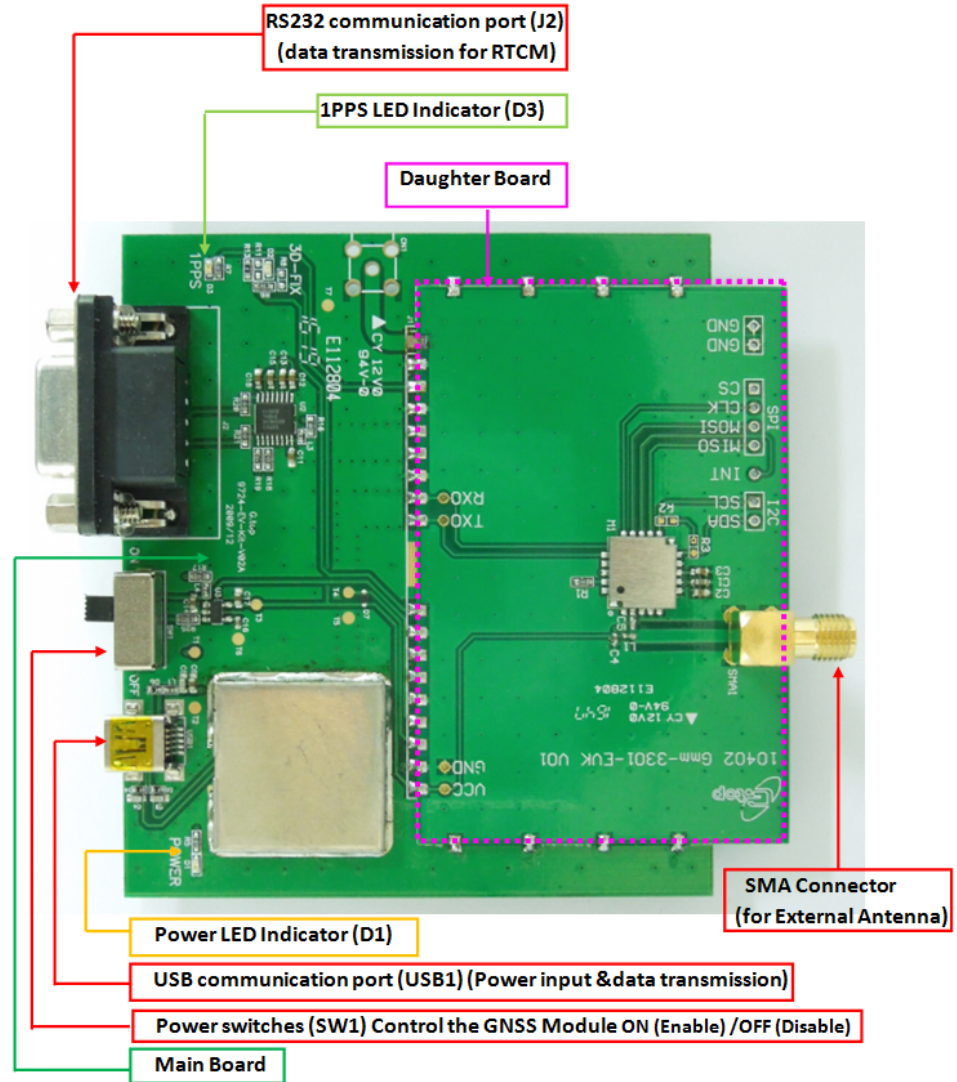

Figure 2-2: Compatible Models (Series 1): XM1100

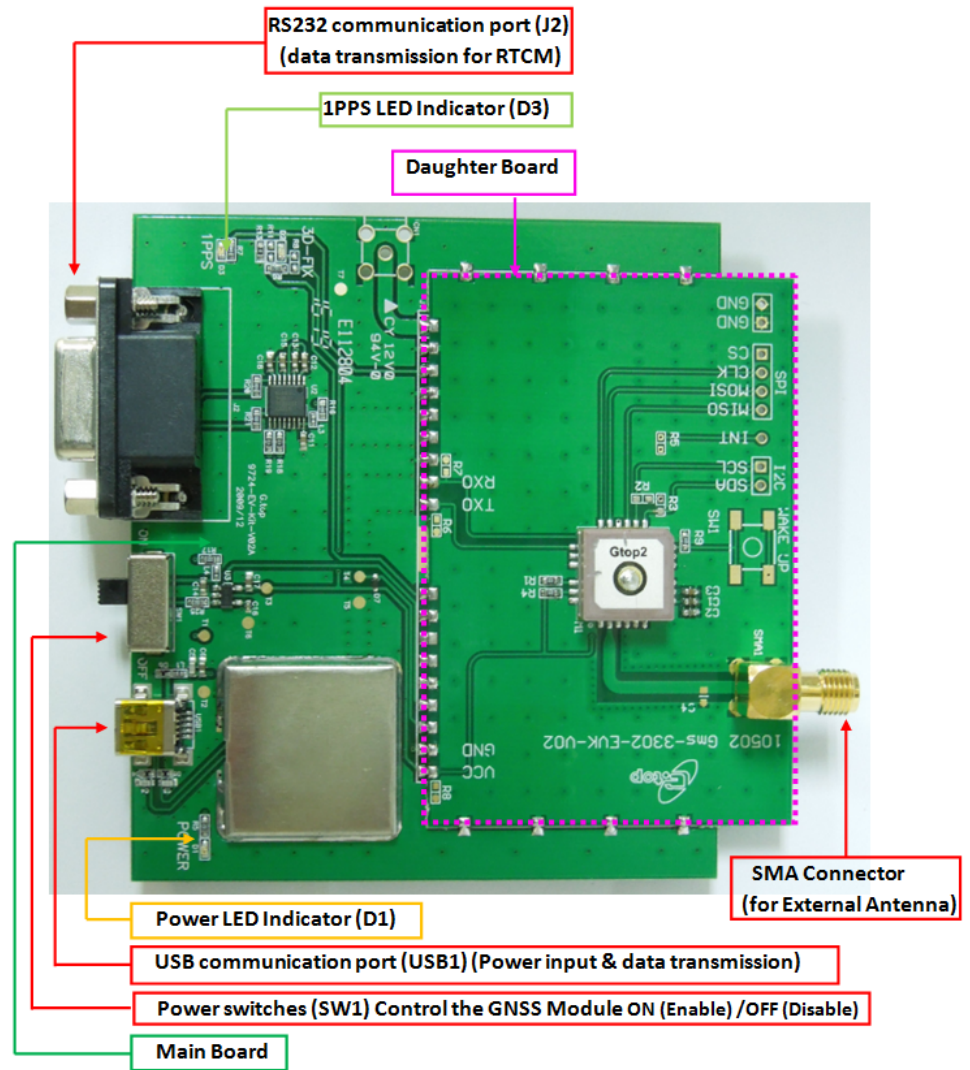

Figure 2-3: Compatible Models (Series 2): XA1100

## 3: Function Testing

### Preparation for Power and Data Communication (not using 3D-Fix function)

1. Connect the USB cable with the PC.
  - The Development Kit will turn on with USB power and the Development Kit will transfer communication data with the PC.
  - Make sure Power LED Indicator (D1) light is lighted on.
2. Turn on the power for the GPS module:
 

The switch enables the LDO to supply power for the GPS Module. Please refer to the figures shown below.

  - a. Once the Power LED Indicator(D1) is on and main board enable switch (SW1) is on, the initial state will be the following:
    - 3D Fix LED Indicator (D2) blinks (blue light).
    - 1PPS LED Indicator (D3) is off (green light).
  - b. Once the module is in the status of FIX:
    - 3D Fix LED Indicator (D2) is off.
    - 1PPS LED Indicator (D3) green is blinking.

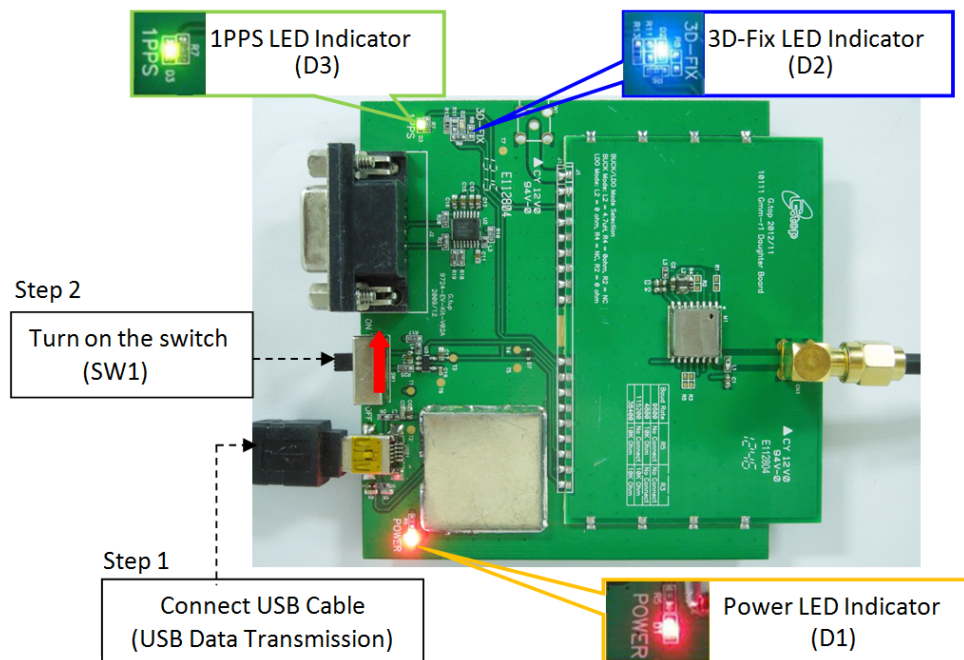

Figure 3-1: Components

## Application for Various RF Reception

1. Use an External Antenna with the GPS Module as shown in [Figure 3-2](#).  
Compatible Model (series1): Ivory 2, XM1110.

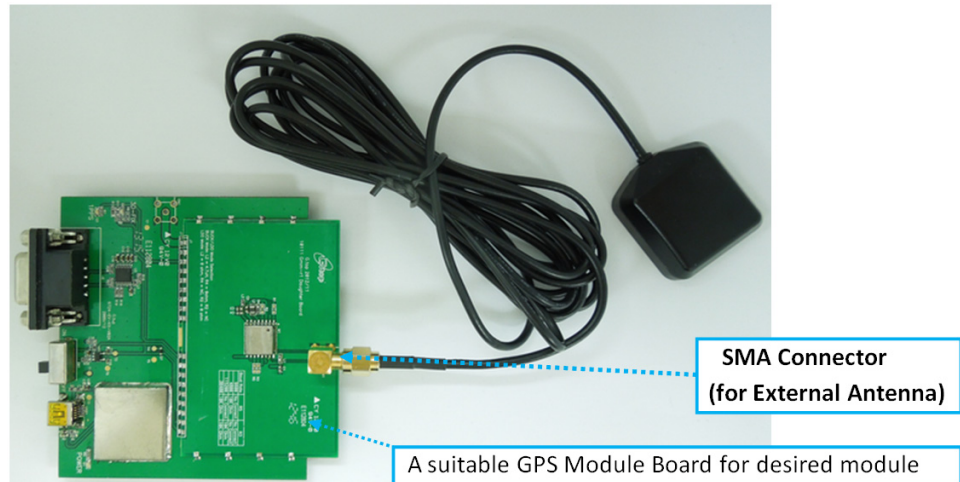

Figure 3-2: Using an External Antenna

2. Connect an External Antenna with the GPS Module as shown in [Figure 3-3](#).  
Compatible Model (series 2): XA1100.

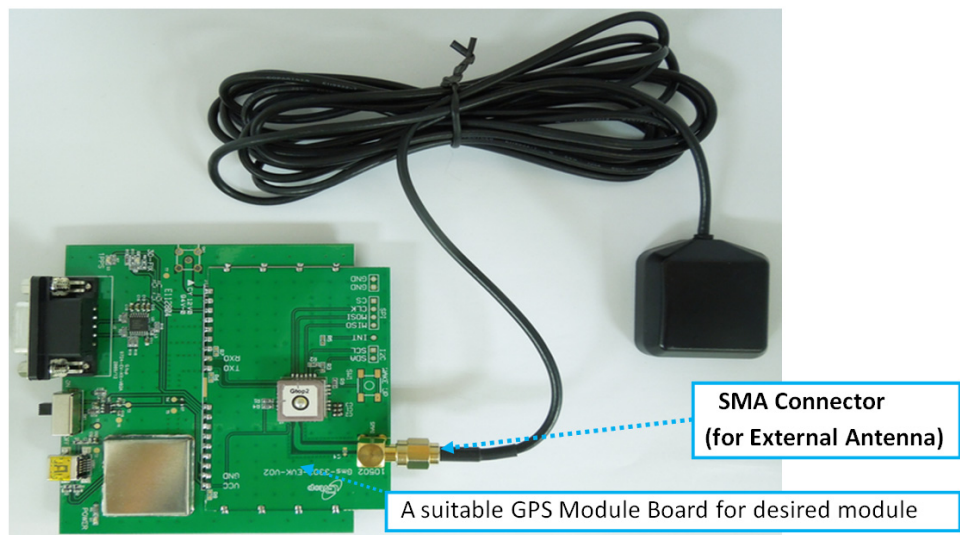

Figure 3-3: Using an External Antenna

As soon as you connect an external antenna, the internal RF switch will wire the RF signal from external antenna. If the external antenna is removed, it will auto-switch to the built-in patch antenna.

---

*Note: the module will detect and connect to the external antenna when it begins to consume >4mA current.*

---

## 4: Software Usage

### System Requirements

- Operating System: Microsoft Windows 7, 8, and 10
- USB Driver: CP210x VCPInstaller.zip  
For Windows 7, Windows 8 or Windows 8.1, please use CP210xVCP driver v6.7 or the latest version (v6.7.5).  
For Windows 10, please use CP210xVCP driver v6.7.5; v10.1.1
- GUI Tool: GNSS Tool
- Microsoft .NET Framework 4.5
- Microsoft Visual C++ 2015 Redistributable Package (x86)

### USB Driver and GNSS Tool

Before setting up the connection between the module and the PC, you will need the Development Kit USB Driver (CP210x VCP) and GNSS Tool.exe to operate the Development Kit.

Please download and install the USB Driver (CP210x VCP) from <https://source.sierrawireless.com/resources/airprime/software/cp210x-windows-drivers>.

Please download the GNSS tool from [https://source.sierrawireless.com/resources/airprime/software/gnss\\_tool/](https://source.sierrawireless.com/resources/airprime/software/gnss_tool/).

---

**Important:** Please check whether you have the correct USB driver before you proceed to the next step. Without the correct driver, the Development Kit will not function.

---

### Installing the USB Driver

1. Double click **CP210x\_VCP\_Win.exe** to begin driver installation:

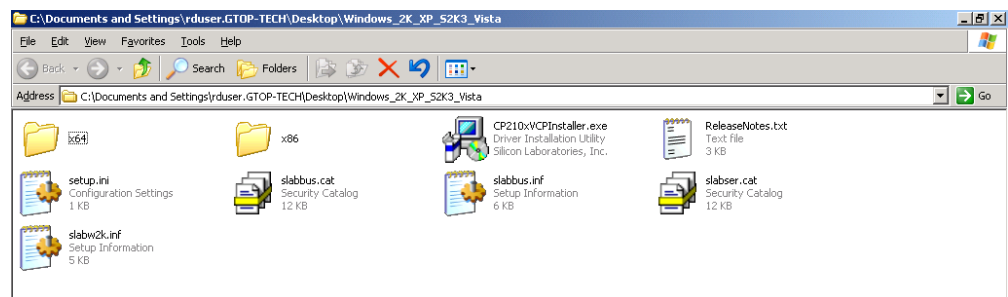

Figure 4-1: Driver Installation Folder

2. Click **Install**:

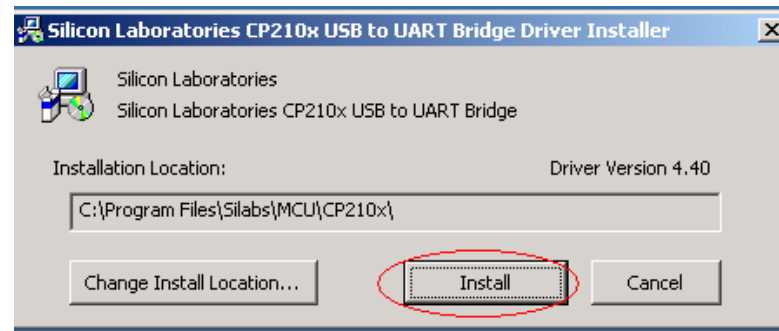

Figure 4-2: Starting the Installation Process

3. After the installation is complete, you may need to restart your computer. Please follow the instructions on screen to restart your computer.
4. After the computer restarted, right click on **My Computer** and select **Manage**:

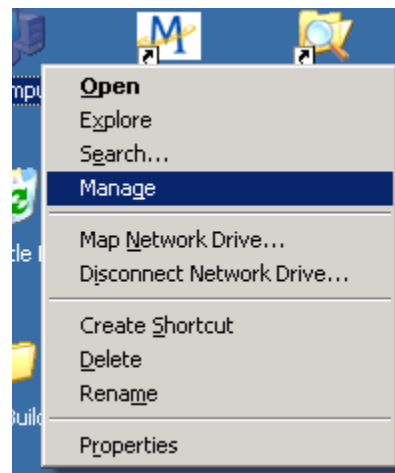

Figure 4-3: Selecting Manage

5. Left click **Device Manager** and select **Ports (COM & LPT)**. Check to see if a device named **Silicon Labs CP210x USB to UART Bridge (COM#)** is present. If so, the Development Kit is set up and ready for use.

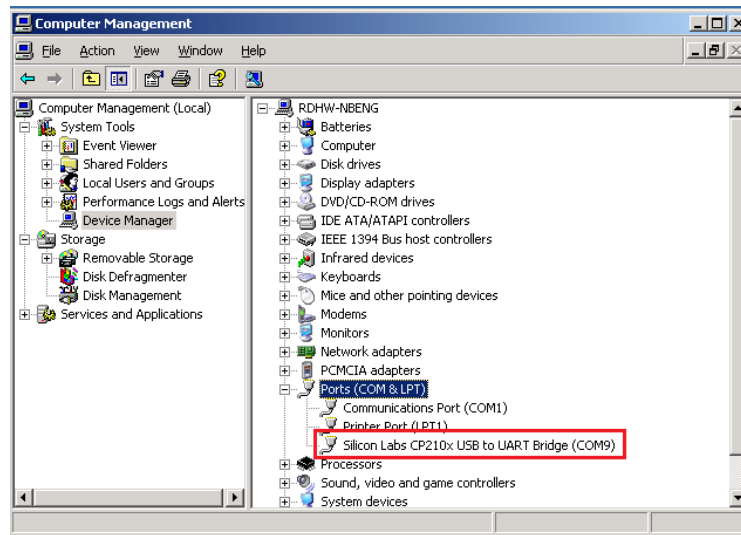

Figure 4-4: Accessing the Port Properties

“COM9” in this example represents the virtual COM port number generated for the USB connection to the Development Kit. This generated COM port value must match the COM port value in the program setting for the application to establish proper communication with the Development Kit.

After completing the installation, please proceed to [Using GNSS Tool](#).

## Using GNSS Tool

Microsoft Framework 4.5 or higher is required before you launch the GNSS Tool software on your PC.

Double click **GNSSTool.exe** to start the application, the main screen of the program is shown here:

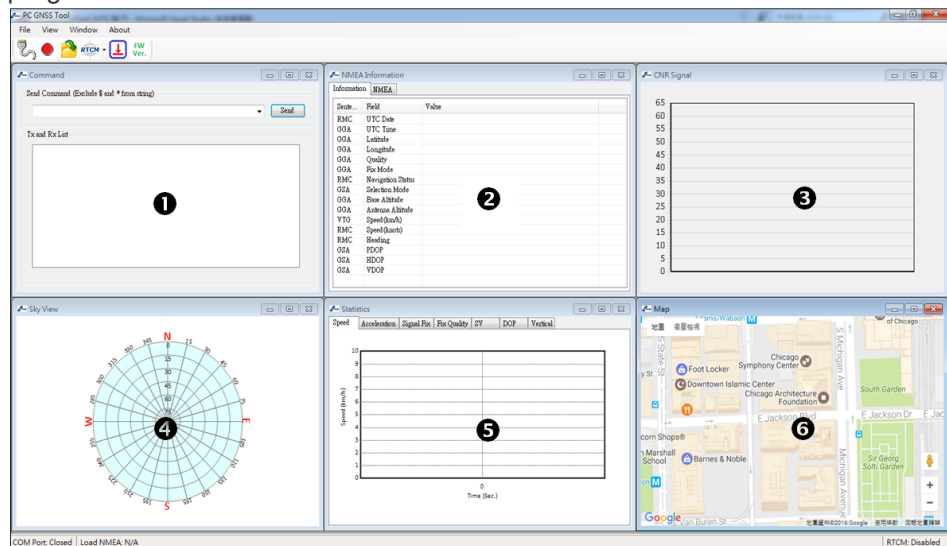

Figure 4-5: GNSS Tool Main Screen

1. **Command Tx and Rx List:** clicking on this menu item will display the Command window.
2. **NMEA List:** clicking on this menu item will display a window with NMEA information.
3. **CNR Signal:** clicking on this menu item will display the CNR signal window.
4. **Sky View:** clicking on this menu item will display a window with a sky view of satellites.
5. **Statistics Plot:** clicking on this menu item will display the statistics plot window.
6. **Map:** clicking on this menu item will display the map window.

After the Development Kit is connected with the PC, please choose the correct **<COM Port>** and **< Baud Rate >** then click the **OK** button and select the appropriate value.

When users click the *Open Communication* menu item or toolbar button, a set up dialog will pop up as shown here:

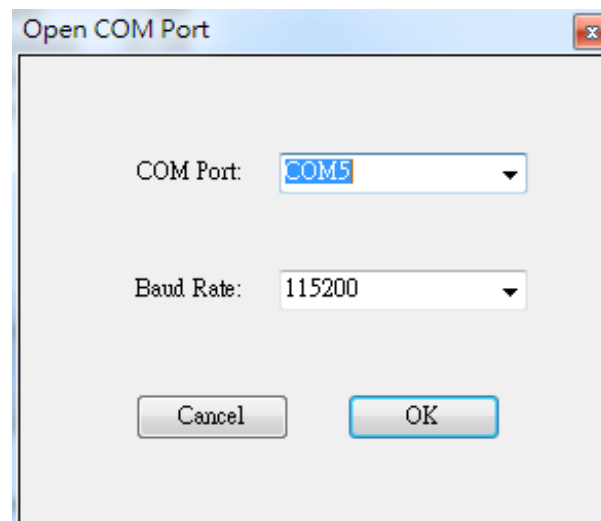

Figure 4-6: COM Port Dialog

If you want more information about the GNSS Tool software, refer to the Sierra Wireless GNSS Tool Operation Manual.

# >> 5: RTCM Hardware Settings

Compatible Models: lovry 2

## Getting RTCM Data via RS232 Port

Connect the RS232 cable to the Development Kit. The RS232 cable is connected to the Development Kit RS232 port (J2) and to the RTCM server (host computer) as shown below:

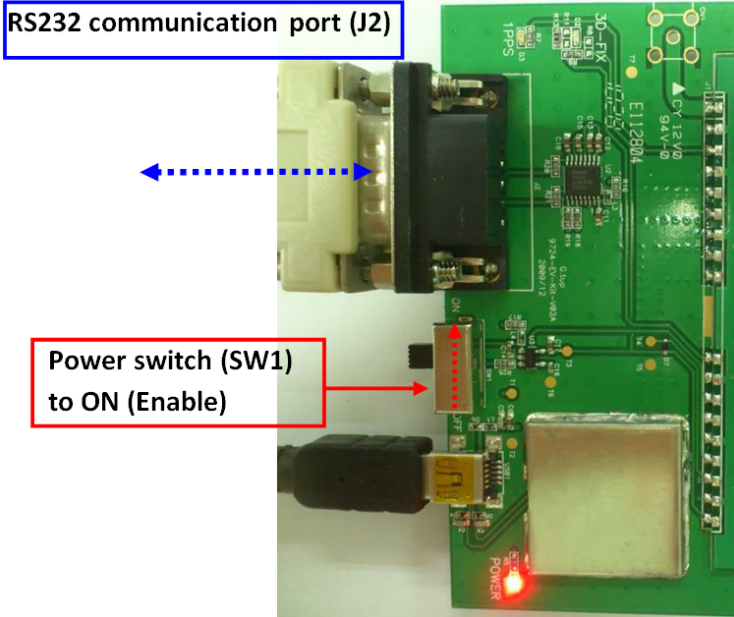

Figure 5-1: RS232 Connection

## 6: RTCM Software Settings

The Ntrip client function can connect to the specified Ntrip caster and create the RTCM streaming. Before connecting to an Ntrip caster, please set up the required parameters properly.

Clicking the drop down arrow show the *Settings* menu:

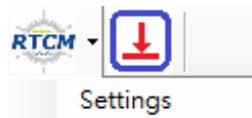

Figure 6-1: Settings Menu

After clicking the *Settings* menu, the *Ntrip Client Settings* dialog pop up as appears as shown below:

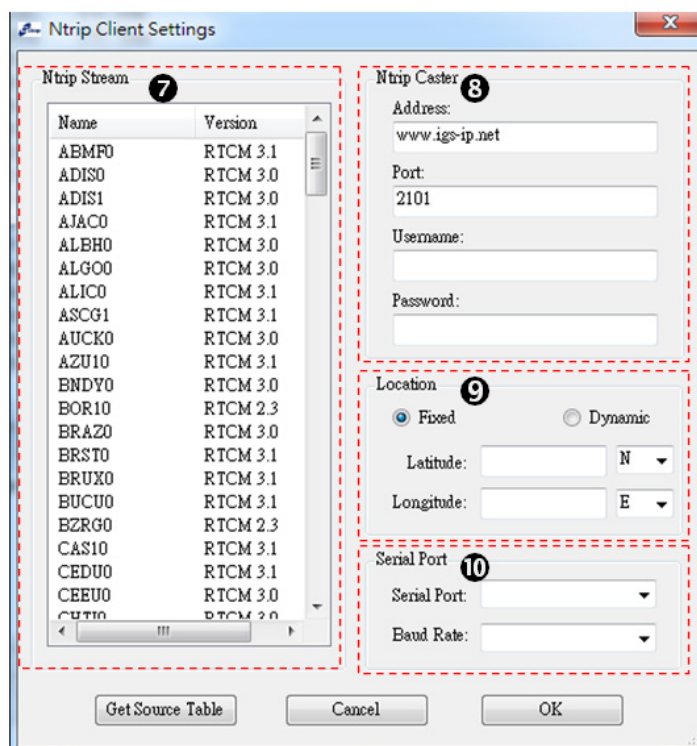

Figure 6-2: Ntrip Client Settings

1. Choose a proper stream which meets yours RTCM version.
2. Input the address and port numbers of the specified caster and the authorized username and password to log in.
3. Designate a fixed location by inputting the latitude and longitude. This reference location information will be sent to the Ntrip caster to get more accurate RTCM correction data.
4. Choose the specified serial port and baud rate.

After the set up is complete click the **RTCM** button to enable the RTCM function as shown here:

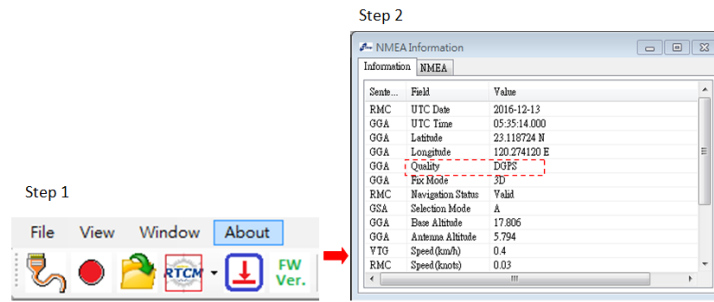

Figure 6-3: Clicking the RTCM button to enable the RTCM function

## >> 7: Troubleshooting

### Setup Troubleshooting

**Table 7-1: Troubleshooting Causes and Solutions**

Problem	Possible Cause	Solution
<b>Cannot find GPS device</b>	USB was not set up properly	Check to see if the Development Kit was set up properly, and make sure that the device is receiving enough power through the USB cable (Red LED should light up continuously).
<b>No NMEA data or GPS signals</b>	<ol style="list-style-type: none"> <li>1. USB was not set up properly.</li> <li>2. COM Port or Baud rate value is incorrect.</li> </ol>	<ol style="list-style-type: none"> <li>1. Check to see if the USB connector to the PC or Development Kit is tightly connected.</li> <li>2. Double check to see if the proper COM Port and Baud rate value are selected.</li> </ol>
<b>Poor GPS Signal Reception</b>	<ol style="list-style-type: none"> <li>1. If it is used inside a vehicle, the anti-sunscreen film on the windshield may interfere and weaken the GPS signal.</li> <li>2. The vehicle is traveling through an area with a dense overhead canopy: such as forest, buildings, open tunnels etc.</li> </ol>	For both problems, the user may apply the External Active Antenna with the Development Kit, and then place the antenna on top of the car's roof to improve signal reception.

---

*Note: if these troubleshooting steps do not solve the problem, please contact us or send it back to us for testing and repair.*

---

## Causes of Poor GPS Signals

It is possible to have weak GPS signal in the following situations:

**Table 7-2: Examples where Poor GPS Signals may Occur**

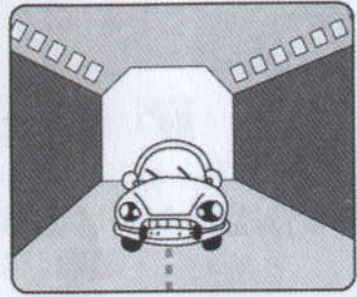
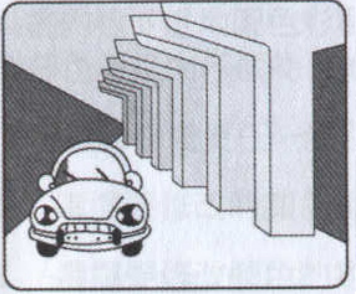
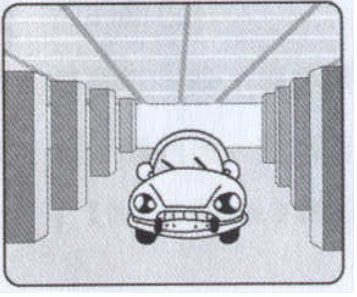
	<p>Inside a tunnel, where the GPS signal is blocked.</p>
	<p>Underneath infrastructure (e.g. bridge), where the GPS signal is blocked.</p>
	<p>Inside a building, where the GPS signal is blocked.</p>

**Table 7-2: Examples where Poor GPS Signals may Occur (Continued)**

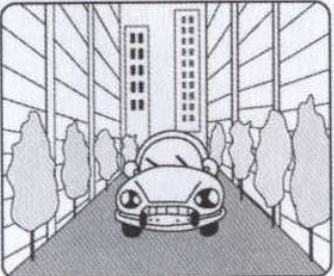
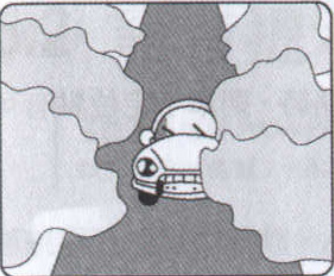
	<p>Next to tall buildings, where the GPS signal is weakened.</p>
	<p>Underneath forests or any other kinds of canopy where GPS signal is weakened.</p>

- If the Development Kit is used inside a car which has anti-sunlight films on the windshield and windows, the GPS signal will be weakened severely, and may result in no GPS reception.
- GPS satellites are property of United States Army. Sometimes they will tune-down the accuracy for unknown reasons. In such cases, the GPS position may not be accurate.