



Product Technical Specification

WP76xx

Important Notice

Information relating to this product and the application or design described herein is believed to be reliable, however such information is provided as a guide only and Semtech assumes no liability for any errors in this document, or for the application or design described herein.

Semtech reserves the right to make changes to the product or this document at any time without notice. Buyers should obtain the latest relevant information before placing orders and should verify that such information is current and complete. Semtech warrants performance of its products to the specifications applicable at the time of sale, and all sales are made in accordance with Semtech's standard terms and conditions of sale.

SEMTECH PRODUCTS ARE NOT DESIGNED, INTENDED, AUTHORIZED OR WARRANTED TO BE SUITABLE FOR USE IN LIFE-SUPPORT APPLICATIONS, DEVICES OR SYSTEMS, OR IN NUCLEAR APPLICATIONS IN WHICH THE FAILURE COULD BE REASONABLY EXPECTED TO RESULT IN PERSONAL INJURY, LOSS OF LIFE OR SEVERE PROPERTY OR ENVIRONMENTAL DAMAGE. INCLUSION OF SEMTECH PRODUCTS IN SUCH APPLICATIONS IS UNDERSTOOD TO BE UNDERTAKEN SOLELY AT THE CUSTOMER'S OWN RISK. Should a customer purchase or use Semtech products for any such unauthorized application, the customer shall indemnify and hold Semtech and its officers, employees, subsidiaries, affiliates, and distributors harmless against all claims, costs damages and attorney fees which could arise.

The Semtech name and logo are registered trademarks of the Semtech Corporation. All other trademarks and trade names mentioned may be marks and names of Semtech or their respective companies. Semtech reserves the right to make changes to, or discontinue any products described in this document without further notice. Semtech makes no warranty, representation or guarantee, express or implied, regarding the suitability of its products for any particular purpose. All rights reserved.

Wireless Communications

Due to the nature of wireless communications, transmission and reception of data can never be guaranteed. Data may be delayed, corrupted (i.e., have errors) or be totally lost. The Semtech product should not be used in situations where failure to transmit or receive data could result in damage of any kind to the user or any other party, including but not limited to personal injury, death, or loss of property. Semtech accepts no responsibility for damages of any kind resulting from delays or errors in data transmitted or received using the Semtech product, or for failure of the Semtech product to transmit or receive such data.

Qualcomm Licenses

Semtech's cellular modules are sold subject to certain notices and restrictions regarding patent licenses from Qualcomm Incorporated. These notices and restrictions are available at www.sierrawireless.com/qualcomm-notices.

Sierra Wireless

Semtech Corporation acquired Sierra Wireless in January 2023. The Sierra Wireless brand is gradually being phased out. During the phase-out period, references to both "Semtech" and "Sierra Wireless" may appear in product documentation.

Contact Information

Sales information and technical support, including warranty and returns	Web: sierrawireless.com/company/contact-us/ Global toll-free number: 1-877-687-7795 6:00 am to 5:00 pm PST
Corporate and product information	Web: sierrawireless.com

Revision History

Revision number	Release date	Changes
1	October 2016	Creation (limited release)
2	February 2017	Updated module numbering Full release
3	March 2017	General update, added current consumption and Rx sensitivity values
4	October 2017	Updated Label image. Removed statements indicating firmware upgrades supported on UART interface. Noted B4 LTE-certified/3G-capable. Updated current consumption values. Updated Power State Transitions figure. Updated Digital I/O Characteristics 1.80V table. Added Digital I/O Characteristics table for GPIO8. Updated Embedded Memory Details table. Removed BAT_RTC content. Updated SDIO voltage level. Updated I2C Interface details. Updated SPI internal device frequency. Updated ADC Interface Characteristics table (ADC3 values). Added warning not to install external pull-ups on UART_RI, UART1_DCD, UART1_DSR. Added Power Supply capacitor requirement (2 x 47 uF). Changed GPIO pull entries to No Pull. Updated UMTS and LTE RF Tx Path Test instructions. Updated Channel numbers in UMTS and LTE RF Tx/Rx test instructions. Updated architecture diagrams (corrected signal names). Updated RESET_IN_N description (indicated internal resistor pull-up, no specified value). Removed USB_VBUS note indicating not connected internally. Identified UART1_DTR as wakeup interrupt. Updated POWER_ON_N assertion time. Added Power Supply Ratings note re: USB_VBUS power. Noted VGPIO power is OFF in ULPM.

Revision number	Release date	Changes
5	February 2018	<p>Clarified WP7603's UMTS network support includes DC-HSPA+, HSPA+, HSPA</p> <p>Updated mechanical diagrams showing LGA pad</p> <p>Updated Architecture section — Architecture Overview figures (updated GPIOs)</p> <p>Updated supply current values</p> <p>Updated UVLO Specifications values and removed associated notes</p> <p>Updated current consumption values for both modules</p> <p>Updated ULPM current consumption values</p> <p>Updated WCDMA and LTE Rx sensitivity values</p> <p>Updated Absolute Maximum Ratings (USB_D-/USB_D+)</p> <p>Updated GPIO8 Digital I/O Characteristics Min value for High-level output voltage</p> <p>Updated Embedded Memory description</p> <p>Emphasized POWER_ON_N suggestion for momentary switch to reduce ULPM leakage</p> <p>Updated SPI speed range</p> <p>Updated product marking example</p> <p>Added Certification Compliance section</p>
6.0	May 14, 2018	<p>Updated WCDMA current consumption values</p> <p>Added Mechanical Specifications topic</p> <p>Merged content from WP7608 PTS and WP7607/WP7609 PTS</p>
6.1	May 30, 2018	<p>Added Power Saving Mode (PSM) on page 45</p> <p>Added Extended Discontinuous Reception (eDRX) on page 48</p> <p>Updated Figure 3-3 on page 44</p> <p>Updated RF on page 60</p> <p>Updated Power-up Sequence on page 92</p> <p>Updated General Purpose Input / Output (GPIO) on page 98</p> <p>Updated I2C Interface on page 102</p> <p>Updated Tx Activity Indicator (TX_ON) on page 117</p>
6.2	June 07, 2018	<p>Updated I2C Interface on page 102</p> <p>Updated Power Saving Mode (PSM) on page 45</p> <p>Updated Table 3-52 on page 72</p> <p>Updated Table 4-7 on page 98</p> <p>Updated Table 10-1 on page 149</p>

Revision number	Release date	Changes
7.0	October 26, 2018	<p>Added POWER_ON_N, RESET_IN_N and AT!POWERDOWN Use Cases on page 93</p> <p>Updated Table 3-10 on page 50</p> <p>Updated Table 3-11 on page 51</p> <p>Updated Table 3-52 on page 72</p> <p>Updated Table 3-53 on page 75</p> <p>Updated Table 3-56 on page 78</p> <p>Updated Table 4-1 on page 91</p> <p>Updated Emergency Power Off on page 93</p> <p>Updated UART on page 94</p> <p>Updated General Purpose Input / Output (GPIO) on page 98</p> <p>Updated GPIO6 on page 99</p> <p>Updated Figure 4-8 on page 108 //OEMTP-1862</p> <p>Updated Figure 4-9 on page 108 //OEMTP-1862</p> <p>Updated Figure 10-1 on page 149</p>
7.1	November 07, 2018	Updated GPIO6 on page 99
7.2	December 12, 2018	<p>Added Secure Boot / Secure Debug on page 87</p> <p>Added eSIM / UIM2 Interface on page 97</p> <p>Updated General Features on page 20 //from LEG 20181206</p> <p>Updated Power Supply Ratings on page 38 //from LEG 20181108</p> <p>Updated Table 3-55 on page 76 //from MLO 20181124</p> <p>Updated Table 4-7 on page 98 //from ATO 20181211</p> <p>Deleted 5.2 PCB Layout Recommendations //OEMTP-2053; from AScherpereel 20181130</p>
8.0	May 23, 2019	<p>Integrated WP7610 PTS (from 41112609)</p> <p>Updated Functional Specifications on page 29</p> <p>Updated Application Core on page 82</p> <p>Updated Embedded Memory on page 82</p> <p>Updated Power Saving Mode (PSM) on page 45</p> <p>Updated Current Consumption on page 50</p> <p>Updated POWER_ON_N on page 91</p>
8.1	June 03, 2019	Updated Table 3-15 on page 57
9.0	July 03, 2019	<p>Integrated WP7605 PTS (from 41113034)</p> <p>Added OTA Considerations when Developing Products that Include an Integrated Antenna on page 122</p> <p>Added PCB Layout Recommendations on page 122</p> <p>Added Japan Regulatory Compliance on page 146</p> <p>Updated Recovery Mechanism on page 87</p> <p>Updated Current Consumption on page 50</p>
9.1	July 10, 2019	<p>Added LTE duplex technology in Introduction on page 2</p> <p>Updated list of configurable GPIOs as ULPS wake up trigger: Table 4-7 on page 98 and Table 4-8 on page 101</p> <p>Removed redundant supported bands table in Telecom Features on page 31</p>
9.2	July 15, 2019	Updated Table 2-2 on page 29

Revision number	Release date	Changes
9.3	July 23, 2019	Updated Recovery Mechanism on page 87
10.0	October 18, 2019	Integrated WP7611 PTS (from 41113043) Updated Table 3-35 on page 66 Updated Table 3-50 on page 71 Updated Table 4-3 on page 93 Updated General Purpose Input / Output (GPIO) on page 98 Updated Important Compliance Information for North American Users on page 143
10.1	November 01, 2019	Added Figure 3-9 on page 90 Updated Figure 1-1 on page 28 Updated Table 3-53 on page 75 Updated WAKE_ON_WWAN on page 118
11.0	January 13, 2020	Added QZSS support in section General Features on page 20 Updated Table 3-3 on page 39 Updated Table 4-7 on page 98 Updated Wakeup Interrupt (Sleep State) on page 100 Updated Table 12-22 on page 171
12	May 2021	Added HSIC Routing Recommendations Updated Figure 2-1, Figure 2-2 (SAFE_PWR_REMOVE W_DISABLE_N directions) Updated Terminology (droop@drop) Updated Table 3-17 (removed WP7605) Updated Table 3-59 (added IPIN) Updated Power On / Off Timing (Note, t_pwr_off_seq timing) Updated UIM Interface (Usage note) Updated VGPI0 (description) Updated Figure 4-15 (signal name — VBAT_RF) Updated SAFE_PWR_REMOVE Updated Ground Plane Connection Updated UIM Interface Updated USB Interface
13	July 2025	Updated to Semtech manual template Updated 4.10.1 General Purpose Input / Output Updated Table 2-1 Variant Grouping Updated 9 Approval to 9 Legal Information Added 9.5.3 Taiwan Regulatory Compliance Added 4.3.1 Software Reset
14	September 2025	Added WP7611D and WP7611D-1
15	December 2025	Updated Table 2-1: Variant Grouping

Contents

- Important Notice 2
- Wireless Communications..... 2
- Qualcomm Licenses 2
- Sierra Wireless 2
- Contact Information 3
- Revision History 3

- 1: Introduction13**
 - 1.1 General Features..... 13
 - 1.2 Interfaces 19
 - 1.3 Common Flexible Form Factor (CF3)..... 20
 - 1.4 Physical Dimensions and Connection Interface..... 20

- 2: Functional Specifications22**
 - 2.1 Variant Grouping 22
 - 2.2 Architecture 23
 - 2.3 Telecom Features 24
 - 2.3.1 Network Technology Specifications 26
 - 2.3.2 Modem Specifications..... 30
 - 2.4 Multi-Core Processing Capabilities 30

- 3: Technical Specifications31**
 - 3.1 Environmental 31
 - 3.2 Power Supply Ratings 31
 - 3.2.1 Under-Voltage Lockout (UVLO) 33
 - 3.2.2 Power Consumption States..... 33
 - 3.2.3 Power Saving Mode (PSM) 38
 - 3.2.4 Active State to ULPS Transition..... 40
 - 3.2.5 Extended Discontinuous Reception (eDRX) 41
 - 3.2.6 Current Consumption 43
 - 3.3 RF..... 53
 - 3.3.1 GSM/GPRS/EDGE RF Interface..... 53

3.3.2 WCDMA RF Interface	54
3.3.3 LTE RF Interface	58
3.3.4 WWAN Antenna Interface	64
3.4 GNSS	66
3.4.1 GNSS Characteristics	66
3.4.2 GNSS Antenna Interface	67
3.5 Electrical Specifications	69
3.5.1 Absolute Maximum Ratings	69
3.5.2 Digital I/O Characteristics	70
3.5.3 Internal Device Frequencies	73
3.6 Processing	73
3.6.1 Application Core	73
3.6.2 Embedded Memory	73
3.6.3 Recovery Mechanism	77
3.6.4 Secure Boot / Secure Debug	78
3.7 Mechanical Drawing	78
3.8 Mechanical Specifications	80
4: Interfaces Specification	81
4.1 Overview	81
4.2 POWER_ON_N	81
4.2.1 Power-up Sequence	81
4.2.2 Software-Initiated Power Down	82
4.3 Emergency Power Off	83
4.3.1 Software Reset	83
4.4 POWER_ON_N, RESET_IN_N and AT!POWERDOWN Use Cases	83
4.5 Tx Power Control	83
4.6 USB	84
4.7 UART	84
4.8 UIM Interface	85
4.8.1 External UIM1 Interface	86
4.8.2 eSIM / UIM2 Interface	87
4.8.3 External SIM Switch Configuration	87

4.9 General Purpose Input/Output (GPIO)	88
4.10 GPIO6	89
4.10.1 General Purpose Input / Output	89
4.10.2 SIM Switching	90
4.10.3 Reset Out	90
4.11 Wakeup Interrupt (Sleep State)	90
4.12 Wakeup Events (ULPS)	91
4.13 Secure Digital IO (SDIO) Interface	91
4.14 I2C Interface	92
4.14.1 Application	92
4.15 VGPIO	93
4.16 Reset Signal (RESET_IN_N)	93
4.17 ADC	94
4.18 Digital Audio	95
4.18.1 I2S	98
4.19 SPI Bus	99
4.19.1 SPI Configuration	100
4.19.2 SPI Waveforms	100
4.19.3 Application	101
4.20 HSIC Bus	101
4.20.1 HSIC Waveforms	101
4.20.2 Application	102
4.21 Clock	102
4.22 TP1 (Boot Pin)	102
4.23 Temperature Monitoring	103
4.24 Test Pins	104
4.25 Antenna Control	105
4.26 Indication Interfaces	105
4.26.1 Tx Activity Indicator (TX_ON)	106
4.26.2 WWAN_LED_N	106
4.26.3 WAKE_ON_WWAN	107
4.26.4 Ring Indicator	108

4.26.5	SAFE_PWR_REMOVE	108
4.26.6	UIM1_DET	108
4.26.7	DR_SYNC	108
4.27	W_DISABLE_N—Wireless Disable	109
5:	Routing Constraints and Recommendations	110
5.1	General Rules and Recommendations	110
5.2	Power Supply	110
5.3	Antenna	110
5.3.1	OTA Considerations when Developing Products that Include an Integrated Antenna. 110	
5.4	PCB Layout Recommendations	111
5.4.1	General Design Rules	111
5.4.2	Specific Design Rules to Support TRP Performances	111
5.4.3	Specific Design Rules to Support TIS Performance	112
5.5	PCB Specifications for the Application Board	112
5.6	Recommended PCB Land Pattern	112
5.7	Routing Constraints	112
5.7.1	Power Supply	112
5.7.2	UIM Interface	113
5.7.3	RF Circuit	114
5.7.4	USB Interface	115
5.7.5	HSIC Routing Recommendations	115
5.8	Thermal Considerations	115
5.9	EMC and ESD Recommendations	116
5.10	Mechanical Integration	117
5.11	Signal Reference Schematics	117
6:	Software and Tools	119
6.1	Support Tools	119
6.2	SED (Smart Error Detection)	119
6.3	Firmware Upgrade	119

6.4 Operating System Upgrade	119
6.5 Product Marking	120
7: Debug and Assembly Considerations	121
7.1 Testing Assistance Provided by Semtech	121
7.1.1 Integration Requirements	121
7.2 IOT/Operator	121
7.3 Module Testing Recommendations.....	121
7.4 Serial Link Access	121
7.5 RF Output Accessibility	122
8: Reliability Specification	123
8.1 Reliability Compliance	123
8.2 Reliability Prediction Model	123
8.2.1 Life Stress Test	123
8.2.2 Environmental Resistance Stress Tests	124
8.2.3 Corrosive Resistance Stress Tests	124
8.2.4 Thermal Resistance Cycle Stress Tests.....	125
8.2.5 Mechanical Resistance Stress Tests.....	126
8.2.6 Handling Resistance Stress Tests.....	128
9: Legal Information	129
9.1 Disposing of the Product	129
9.2 Important Notice.....	129
9.3 Safety and Hazards	129
9.4 Compliance Acceptance and Certification	130
9.5 Certification Compliance.....	130
9.5.1 Important Compliance Information for North American Users.....	130
9.5.2 Japan Regulatory Compliance.....	132
9.5.3 Taiwan Regulatory Compliance	133
10: Pinout	134
10.1 Pin Configuration	135

10.2 Pin Description	135
11: Customization	144
12: Testing	145
12.1 Certification Testing.....	145
12.2 Production Testing.....	145
12.3 Functional Production Test.....	146
12.3.1 Suggested Production Tests.....	146
12.3.2 Production Test Procedure.....	146
12.4 UMTS (WCDMA/GSM) RF Transmission Path Test.....	148
12.5 LTE RF Transmission Path Test.....	150
12.6 UMTS (WCDMA/GSM) RF Receive Path Test	154
12.7 LTE RF Receive Path Test	157
12.8 GNSS RF Receive Path Test.....	160
A: Appendix	161
A.1 Website Support.....	161
A.2 Reference Documents.....	161
A.3 Abbreviations.....	161

1: Introduction

This document defines the high-level product features and illustrates the interfaces for AirPrime WP76XX Smart Embedded Modules (WP7601, WP7601-1, WP7603, WP7603-1, WP7605, WP7607, WP7607-1, WP7608, WP7608-1, WP7609, WP7610, WP7611, WP7611-1, WP7611D, WP7611D-1). It covers the hardware aspects of the product series, including electrical and mechanical.

Note: Throughout this document, references to WP7601, WP7603, WP7607, WP7608, WP7611, and WP7611D are to be read as WP7601/WP7601-1, WP7603/WP7603-1, WP7607/WP7607-1, WP7608/WP7608-1, WP7611/WP7611-1, and WP7611D/WP7611D-1 unless module variants are called out separately.

1.1 General Features

The AirPrime WP76XX is an industrial-grade LGA 239-pad embedded module. Its wireless modem provides voice and data connectivity on the networks listed in [Table 1-1](#).

Table 1-1: Supported Networks and Voice Capability

Module	Networks	Network Voice Support	LTE Category
WP7601	LTE	No	Cat4
WP7601-1			Cat1
WP7603	LTE UMTS (DC-HSPA+, HSPA+, HSPA, WCDMA)	Circuit switch voice	Cat4
WP7603-1			Cat1
WP7605	LTE UMTS (DC-HSPA+, HSPA+, HSPA, WCDMA)	Circuit switch voice + VoLTE	Cat4
WP7607	LTE UMTS (DC-HSPA+, HSPA+, HSPA, WCDMA) GSM/GPRS/EDGE	Circuit switch voice + VoLTE	Cat4
WP7607-1			Cat1
WP7608	LTE UMTS (DC-HSPA+, HSPA+, HSPA, WCDMA) GSM/GPRS/EDGE	Circuit switch voice + VoLTE	Cat4
WP7608-1			Cat1
WP7609	LTE UMTS (DC-HSPA+, HSPA+, HSPA, WCDMA) GSM/GPRS/EDGE	Circuit switch voice + VoLTE	Cat4
WP7610	LTE UMTS (DC-HSPA+, HSPA+, HSPA, WCDMA)	Circuit switch voice + VoLTE	Cat4
WP7611	LTE, UMTS (DC-HSPA+, HSPA+, HSPA, WCDMA)	Circuit switch voice + VoLTE	Cat4
WP7611-1			Cat1
WP7611D	LTE, UMTS (DC-HSPA+, HSPA+, HSPA, WCDMA)	Data	Cat4
WP7611D-1			Cat1

To simplify cellular connectivity, the AirPrime WP76xx has been designed to support Ready-To-Connect, and an embedded SIM (eSIM) has been natively designed in the AirPrime WP76xx for this purpose. To learn more about Ready-To-Connect capabilities and to know which variant already supports this feature, please get in touch with your Semtech sales representative.

GNSS functionality is available on all module variants as a SKU-dependent feature.

In addition to modem features, the AirPrime WP76XX embeds several cores for maximum flexibility and security for embedded software execution, including:

- A Telecom Core that natively manages 2G (WP7607, WP7608, WP7609), 3G (WP7603, WP7605, WP7607, WP7608, WP7609, WP7610, WP7611, WP7611D) and 4G modem features
- An Application Core dedicated to customer applications, natively provided with Legato Application framework.

The following tables detail supported RF bands/connectivity.

Table 1-2: WP7601 Supported Bands / Connectivity

Technology	RF Band	Transmit Band (Tx) (MHz)	Receive Band (Rx) (MHz)	Maximum Output Power	Notes
LTE	B4 (FDD) ^a	1710–1755	2110–2155	23 dBm ± 1 dB; Class 3	MIMO ^b and diversity
	B13 (FDD)	777–787	746–756		
GNSS	GPS	-	1575.42 ± 1.023	-	-
	GLONASS	-	1597.52–1605.92	-	-
	Galileo	-	1575.42 ± 2.046	-	-
	BeiDou	-	1561.098 ± 2.046	-	-
	QZSS	-	1575.42 ± 2.046	-	-

- a. B4 is LTE-certified and 3G-capable, requires validation/certification for 3G use.
 b. Cat4 variant supports downlink MIMO 2x2.

Table 1-3: WP7603 Supported Bands / Connectivity

Technology	RF Band	Transmit Band (Tx) (MHz)	Receive Band (Rx) (MHz)	Maximum Output Power	Notes
LTE	B2 (FDD)	1850–1910	1930–1990	23 dBm ± 1 dB; Class 3	MIMO ^a and diversity
	B4 (FDD)	1710–1755	2110–2155		
	B5 (FDD)	824–849	869–894		
	B12 (FDD)	699–716	729–746		
UMTS	B2	1850–1910	1930–1990	23 dBm ± 1 dB; Class 3bis	Diversity
	B4	1710–1755	2110–2155		
	B5	824–849	869–894		

Table 1-3: WP7603 Supported Bands / Connectivity (Continued)

Technology	RF Band	Transmit Band (Tx) (MHz)	Receive Band (Rx) (MHz)	Maximum Output Power	Notes
GNSS	GPS	-	1575.42 ± 1.023	-	-
	GLONASS	-	1597.52–1605.92	-	-
	Galileo	-	1575.42 ± 2.046	-	-
	BeiDou	-	1561.098 ± 2.046	-	-
	QZSS	-	1575.42 ± 2.046	-	-

a. Cat4 variant supports downlink MIMO 2x2.

Table 1-4: WP7605 Supported Bands / Connectivity

Technology	RF Band	Transmit Band (Tx) (MHz)	Receive Band (Rx) (MHz)	Maximum Output Power	Notes
LTE	B1 (FDD)	1920 – 1980	2110 – 2170	23 dBm ± 1 dB; Class 3	MIMO ^a and diversity
	B3 (FDD)	1710 – 1785	1805 – 1880		
	B8 (FDD)	880 – 915	925 – 960		
	B11 (FDD)	1427.9 – 1447.9	1475.9 – 1495.9		
	B18 (FDD)	815 – 830	860 – 875		
	B19 (FDD)	830 – 845	875 – 890		
	B21 (FDD)	1447.9 – 1462.9	1495.9 – 1510.9		
UMTS	B1	1920 – 1980	2110 – 2170	23 dBm ± 1 dB; Class 3bis	Diversity
	B6	830 – 840	875 – 885		
	B19	830 – 845	875 – 890		
GNSS	GPS	-	1575.42 ± 1.023	-	-
	GLONASS	-	1597.52–1605.92	-	-
	Galileo	-	1575.42 ± 2.046	-	-
	BeiDou	-	1561.098 ± 2.046	-	-
	QZSS	-	1575.42 ± 2.046	-	-

a. Cat4 variant supports downlink MIMO 2x2.

Table 1-5: WP7607 Supported Bands / Connectivity

Technology	RF Band	Transmit Band (Tx) (MHz)	Receive Band (Rx) (MHz)	Maximum Output Power	Notes
LTE	B1 (FDD)	1920–1980	2110–2170	23 dBm ± 1 dB; Class 3	MIMO ^a and diversity
	B3 (FDD)	1710–1785	1805–1880		
	B7 (FDD)	2500–2570	2620–2690		
	B8 (FDD)	880–915	925–960		
	B20 (FDD)	832–862	791–821		
	B28 (FDD)	703–748	758–803		
UMTS	B1	1920–1980	2110–2170	23 dBm ± 1 dB; Class 3bis	Diversity
	B8	880–915	925–960		
GSM/GPRS/EDGE	E-GSM 900	880–915	925–960	33 dBm ± 1 dB; GMSK mode Power Class 4; 27 dBm ± 1 dB; 8PSK mode Power Class E2	
	DCS 1800	1710–1785	1805–1880	30 dBm ± 1 dB; GMSK mode Power Class 1; 26 dBm ± 1 dB; 8PSK mode Power Class E2	
GNSS	GPS	-	1575.42 ± 1.023	-	-
	GLONASS	-	1597.52–1605.92	-	-
	Galileo	-	1575.42 ± 2.046	-	-
	BeiDou	-	1561.098 ± 2.046	-	-
	QZSS	-	1575.42 ± 2.046	-	-

a. Cat4 variant supports downlink MIMO 2x2.

Table 1-6: WP7608 Supported Bands / Connectivity

Technology	RF Band	Transmit Band (Tx) (MHz)	Receive Band (Rx) (MHz)	Maximum Output Power	Notes
LTE	B1 (FDD)	1920–1980	2110–2170	23 dBm ± 1 dB; Class 3	MIMO ^a and diversity
	B3 (FDD)	1710–1785	1805–1880		
	B5 (FDD)	824–849	869–894		
	B8 (FDD)	880–915	925–960		
	B40 (TDD)	2300–2400	2300–2400		
	B41 (TDD)	2535–2655	2535–2655		
UMTS	B1	1920–1980	2110–2170	24 dBm ± 1 dB; Class 3	Diversity
	B8	880–915	925–960		

Table 1-6: WP7608 Supported Bands / Connectivity (Continued)

Technology	RF Band	Transmit Band (Tx) (MHz)	Receive Band (Rx) (MHz)	Maximum Output Power	Notes
GSM/GPRS/EDGE	E-GSM 900	880–915	925–960	33 dBm \pm 1 dB; GMSK mode Power Class 4; 27 dBm \pm 1 dB; 8PSK mode Power Class E2	
	DCS 1800	1710.2–1784.8	1805.2–1879.8	30 dBm \pm 1 dB; GMSK mode Power Class 1; 26 dBm \pm 1 dB; 8PSK mode Power Class E2	
GNSS	GPS	-	1575.42 \pm 1.023	-	-
	GLONASS	-	1597.52–1605.92	-	-
	Galileo	-	1575.42 \pm 2.046	-	-
	BeiDou	-	1561.098 \pm 2.046	-	-
	QZSS	-	1575.42 \pm 2.046	-	-

a. Cat4 variant supports downlink MIMO 2x2.

Table 1-7: WP7609 Supported Bands / Connectivity

Technology	RF Band	Transmit Band (Tx) (MHz)	Receive Band (Rx) (MHz)	Maximum Output Power	Notes
LTE	B1 (FDD)	1920–1980	2110–2170	23 dBm \pm 1 dB; Class 3	MIMO ^a and diversity
	B3 (FDD)	1710–1785	1805–1880		
	B5 (FDD)	824–849	869–894		
	B7 (FDD)	2500–2570	2620–2690		
	B8 (FDD)	880–915	925–960		
	B28 (FDD)	703–748	758–803		
UMTS	B1	1920–1980	2110–2170	23 dBm \pm 1 dB; Class 3bis	Diversity
	B5	824–849	869–894		
	B8	880–915	925–960		
GSM/GPRS/EDGE	E-GSM 900	880–915	925–960	33 dBm \pm 1 dB; GMSK mode Power Class 4; 27 dBm \pm 1 dB; 8PSK mode Power Class E2	
	DCS 1800	1710–1785	1805–1880	30 dBm \pm 1 dB; GMSK mode Power Class 1; 26 dBm \pm 1 dB; 8PSK mode Power Class E2	

Table 1-7: WP7609 Supported Bands / Connectivity (Continued)

Technology	RF Band	Transmit Band (Tx) (MHz)	Receive Band (Rx) (MHz)	Maximum Output Power	Notes
GNSS	GPS	-	1575.42 ± 1.023	-	-
	GLONASS	-	1597.52–1605.92	-	-
	Galileo	-	1575.42 ± 2.046	-	-
	BeiDou	-	1561.098 ± 2.046	-	-
	QZSS	-	1575.42 ± 2.046	-	-

a. Downlink MIMO 2x2.

Table 1-8: WP7610 Supported Bands / Connectivity

Technology	RF Band	Transmit Band (Tx) (MHz)	Receive Band (Rx) (MHz)	Maximum Output Power	Notes
LTE	B2 (FDD)	1850–1910	1930–1990	23 dBm ± 1 dB; Class 3	MIMO ^a and diversity
	B4 (FDD)	1710–1755	2110–2155		
	B5 (FDD)	824–849	869–894		
	B12 (FDD)	699–716	729–746		
	B13 (FDD)	777–787	746–756		
	B14 (FDD)	788–798	758–768		
	B17 (FDD)	704–716	734–746		
	B66 (FDD)	1710–1780	2110–2200		
UMTS	B2	1850–1910	1930–1990	23 dBm ± 2 dB; Class 3bis	Diversity
	B4	1710–1755	2110–2155		
	B5	824–849	869–894		
GNSS	GPS	-	1575.42 ± 1.023	-	-
	GLONASS	-	1597.52–1605.92	-	-
	Galileo	-	1575.42 ± 2.046	-	-
	BeiDou	-	1561.098 ± 2.046	-	-
	QZSS	-	1575.42 ± 2.046	-	-

a. Downlink MIMO 2x2.

Table 1-9: WP7611, WP7611D Supported Bands/Connectivity

Technology	RF Band	Transmit Band (Tx) (MHz)	Receive Band (Rx) (MHz)	Maximum Output Power	Notes
LTE	B2 (FDD)	1850 – 1910	1930 – 1990	23 dBm ± 1 dB	MIMO ^a and diversity
	B4 (FDD)	1710 – 1755	2110 – 2155		
	B5 (FDD)	824 – 849	869 – 894		
	B12 (FDD)	699 – 716	729 – 746		
	B13 (FDD)	777 – 787	746 – 756		
	B14 (FDD)	788 – 798	758 – 768		
	B25 (FDD)	1850 – 1915	1930 – 1995		
	B26 (FDD)	814 – 849	859 – 894		
	B66 (FDD)	1710 – 1780	2110 – 2200		
	B71 (FDD)	663 – 698	617 – 652		
UMTS	B2	1850 – 1910	1930 – 1990	23 dBm ± 1 dB; Class 3bis	Diversity
	B4	1710 – 1755	2110 – 2155		
	B5	824 – 849	869 – 894		
GNSS	GPS	-	1575.42 ± 1.023	-	-
	GLONASS	-	1597.52–1605.92	-	-
	Galileo	-	1575.42 ± 2.046	-	-
	BeiDou	-	1561.098 ± 2.046	-	-
	QZSS	-	1575.42 ± 2.046	-	-

a. Downlink MIMO 2x2.

1.2 Interfaces

The AirPrime WP76XX provides the following interfaces and peripheral connectivity:

- Digital section running under 1.8V
- UIM interface — See [UIM Interface](#) on page 85.
 - eSIM — See [eSIM / UIM2 Interface](#) on page 87.
- VBAT_RF/VBAT_BB power supply — See [Power Supply Ratings](#) on page 31.
- RF — See [RF](#) on page 53.
- GNSS (RF_GNSS) — See [GNSS](#) on page 66.
- ON/OFF control:
 - POWER_ON_N — See [POWER_ON_N](#) on page 81.
 - RESET_IN_N — See [Reset Signal \(RESET_IN_N\)](#) on page 93.
- USB 2.0 — See [USB](#) on page 84.
- UART serial links — See [UART](#) on page 84.
- GPIOs — See [General Purpose Input/Output \(GPIO\)](#) on page 88.
- SDIO — See [Secure Digital IO \(SDIO\) Interface](#) on page 91.

- I²C— See [I2C Interface](#) on page 92.
- 1.8V voltage reference— See [VGPI0](#) on page 93.
- ADCs— See [ADC](#) on page 94.
- Digital audio (PCM/I²S)— See [Digital Audio](#) on page 95.
- SPI bus— See [SPI Bus](#) on page 99.
- HSIC bus— See [HSIC Bus](#) on page 101.
- Antenna control— See [Antenna Control](#) on page 105.
- System clock outputs— See [Clock](#) on page 102.
- Test pins— See [Test Pins](#) on page 104.
- Tx Activity Indicator (TX_ON)— See [Tx Activity Indicator \(TX_ON\)](#) on page 106.

1.3 Common Flexible Form Factor (CF3)

The AirPrime WP76XX belongs to the Common Flexible Form Factor (CF3) family of WWAN modules. These modules share the same mechanical dimensions (same width and length with varying thicknesses) and footprint. The CF3 form factor provides a unique solution to a series of problems faced commonly in the WWAN module space as it:

- Accommodates multiple radio technologies (from GSM to LTE advanced) and band groupings
- Supports bit-pipe (Essential Module Series) and value-add (Smart Module Series) solutions
- Offers electrical and functional compatibility

1.4 Physical Dimensions and Connection Interface

The AirPrime WP76XX module is a compact, robust, fully shielded and labeled (laser-etched) module with the dimensions noted in [Table 1-10](#).

Table 1-10: Module Dimensions^a

Parameter	Nominal	Tolerance	Units
Length	23.00	±0.10	mm
Width	22.00	±0.10	mm
Thickness	2.50	±0.20	mm
Weight	2.6	±1.0	g

a. Dimensions are accurate as of the release date of this document.

The AirPrime WP76XX module is an LGA form factor device. All electrical and mechanical connections are made through the 239 Land Grid Array (LGA) pads on the bottom side of the PCB. (See [Figure 10-1](#) on page 135 for details.)

Note: The following figure shows top/bottom views of the unlabeled module. For a product marking example, see [Figure 6-1](#) on page 120.

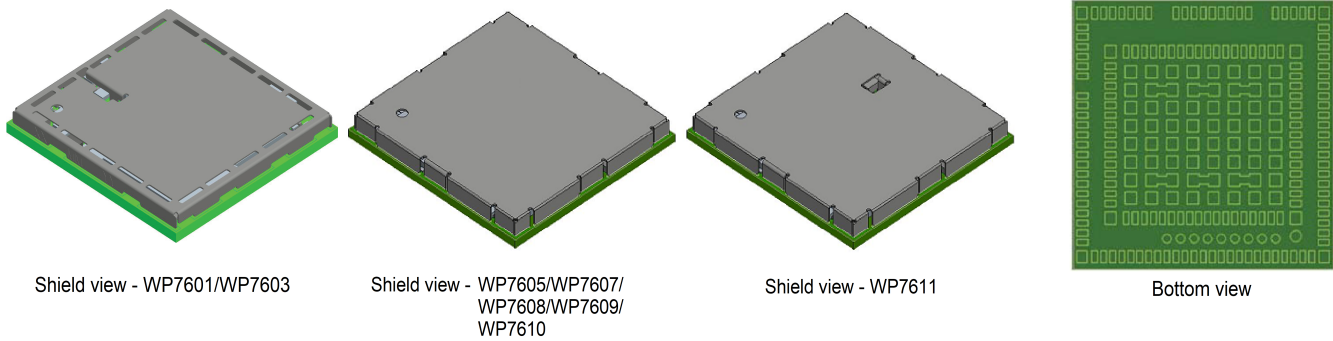


Figure 1-1: Mechanical Overview

The 239 pads have the following distribution:

Table 1-11: LGA Pad Types

Pad Type / Quantity		Dimensions	Pitch
Signal Pads	66 inner pads	1.0x0.5 mm	0.8 mm
	91 outer pads		
Test Points	1 polarity mark (Ground)	1.0 mm (diameter)	-
	9 test points	0.8 mm (diameter)	1.20 mm
Ground Pads	64 inner pads	1.0x1.0 mm	1.83 mm/ 1.48 mm
	4 inner corner pads	1.0x1.0 mm	-
	4 outer corner pads	1.0x0.9 mm	-

2: Functional Specifications

2.1 Variant Grouping

WP76xx modules can be categorized into two groups:

- Group A variants:
 - contain an on-board micro-controller (MCU)
 - support Ultra Low Power Mode (ULPM)
- Group B variants:
 - do not have an MCU
 - do not support ULPM

Table 2-1: Variant Grouping

Group	Variant
A	WP7601, WP7603, WP7607, WP7608, WP7609
B	WP7605, WP7610, WP7611, WP7611D

The following table provides additional information between Group A and Group B WP76xx variants.

Table 2-2: Functionality Differences

Group ^a	Interface	Function/Description	Notes
Group A only	GPIO36, GPIO38, ADC2, ADC3	ULPM Interrupt/Trigger	See Table 3-5 on page 34 and Active State to ULPS Transition on page 40
		Wakeup Event (ULPM)	See Wakeup Events (ULPS) on page 91
		Current Consumption	See Table 3-17 on page 52
	GPIO36, GPIO37, GPIO38, GPIO40, GPIO41	Extra GPIO	See Table 4-7 on page 88
	GPIO36, GPIO38	Wakeup Interrupt (USB-SS mode)	See Wakeup Interrupt (Sleep State) on page 90
Group A and Group B	ADC2, ADC3	Extra ADC	See ADC on page 94
	POWER_ON_N, RESET_IN_N	Use case differences	See POWER_ON_N, RESET_IN_N and AT!POWERDOWN Use Cases on page 83

a. Refer to [Table 2-1](#) on page 22 for variant grouping.

All other interfaces and functionalities are supported by both Group A and Group B variants.

2.2 Architecture

The following figures present overviews of the AirPrime WP76XX modules' internal architecture and external interfaces.

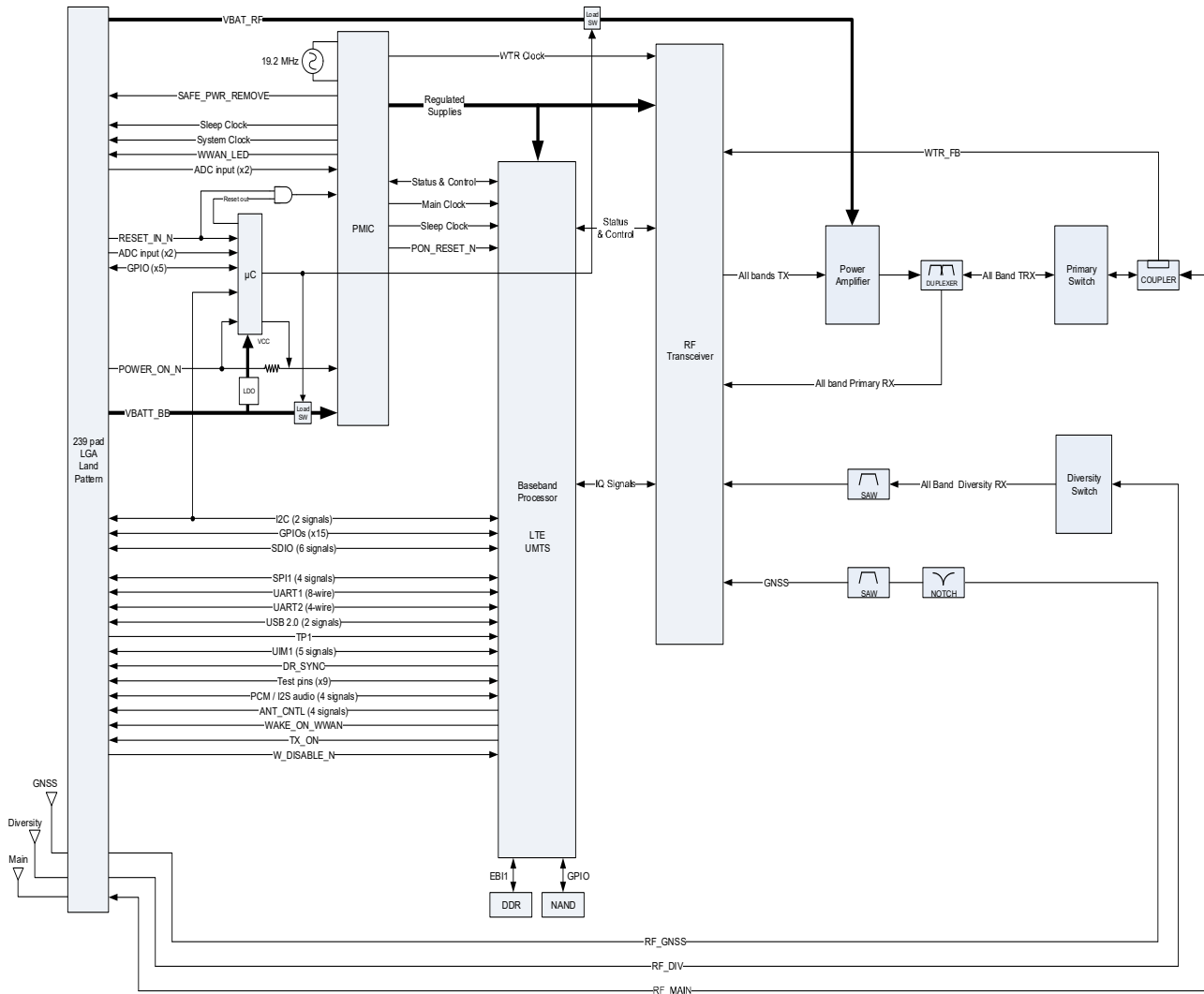


Figure 2-1: Architecture Overview of Group A Variants

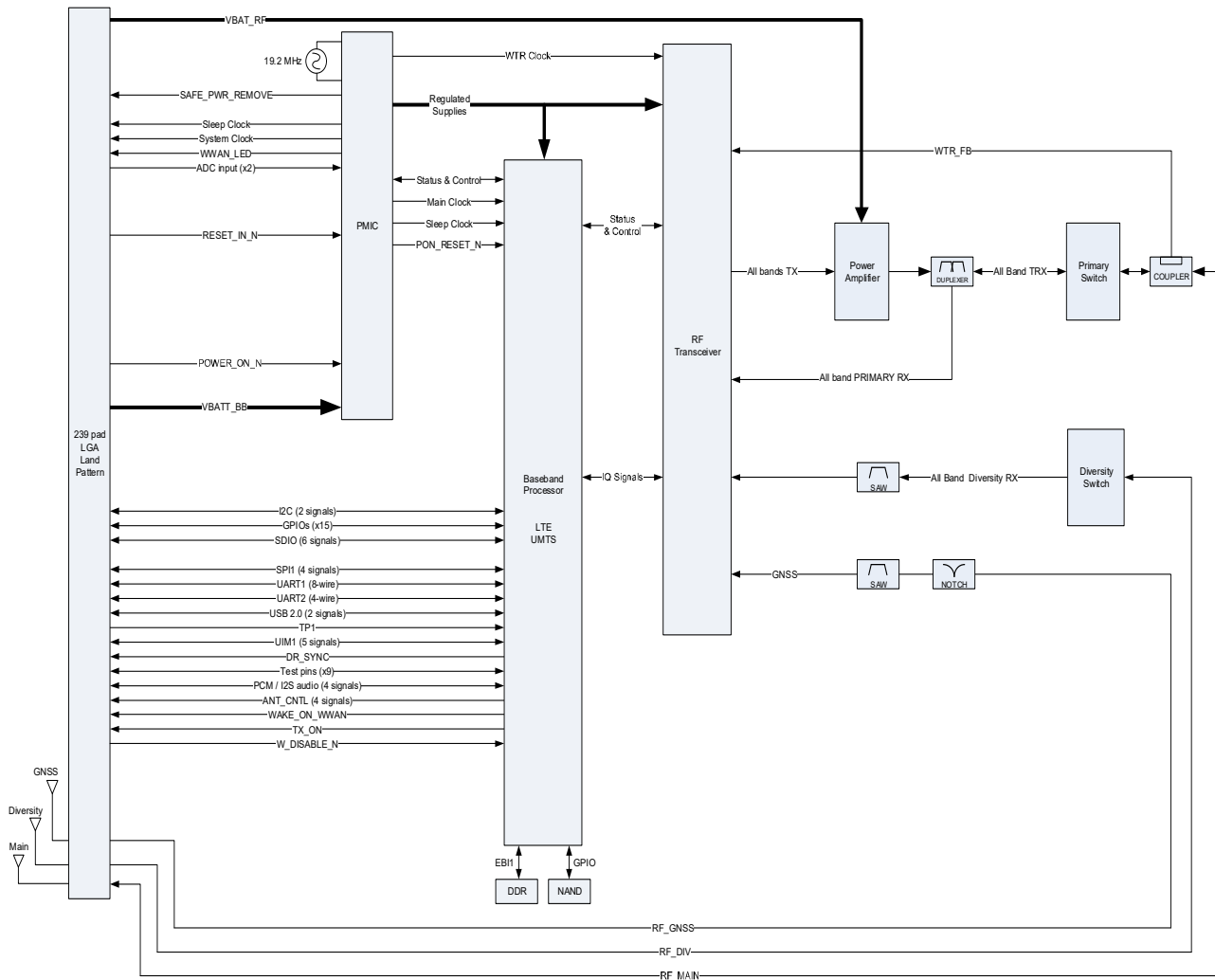


Figure 2-2: Architecture Overview of Group B Variants

2.3 Telecom Features

Table 2-3 summarizes the AirPrime WP76XX module’s capabilities offered through the Telecom core.

Table 2-3: Module Capabilities

Feature	Description
Electrical	3.4–4.3V supply voltage (VBAT_BB, VBAT_RF): <ul style="list-style-type: none"> Single supply (recommended), VBAT_BB tied to VBAT_RF or Dual supplies, single supply each for VBAT_BB and VBAT_RF

Table 2-3: Module Capabilities

Feature	Description
Voice (Digital Audio)	<ul style="list-style-type: none"> ▪ PCM/12S digital audio interface ▪ Supports Enhanced Full Rate (EFR), Full Rate (FR), Half Rate (HR), and both Narrow-Band and Wide-band Adaptive Multirate (AMR-NB and AMR-WB) vocoders ▪ MO and MT calling ▪ Echo cancellation and noise reduction ▪ Emergency calls (112, 110, 911, etc.) ▪ Incoming call notification ▪ DTMF generation ▪ Internal codec driver for WM8944
SMS	<ul style="list-style-type: none"> ▪ SMS MO and MT ▪ CS and PS support ▪ SMS saving to UIM card or ME storage ▪ SMS reading from UIM card or ME storage ▪ SMS sorting ▪ SMS concatenation ▪ SMS Status Report ▪ SMS replacement support ▪ SMS storing rules (support of AT+CNMI, AT+CNMA)
Supplementary services	<ul style="list-style-type: none"> ▪ Call Barring ▪ Call Forwarding ▪ Call Hold ▪ Caller ID ▪ Call Waiting ▪ Multi-party service ▪ USSD ▪ Automatic answer

2.3.1 Network Technology Specifications

2.3.1.1 GSM/GPRS/EDGE Specifications

The following table describes GSM/GPRS/EDGE specifications for WP7607/WP7608/WP7609 modules.

Table 2-4: Supported GSM Specifications^a

Standard	Feature Description
GPRS	Packet-switched data: <ul style="list-style-type: none"> ▪ DTM (simple class A) operation ▪ GPRS Multislot class 10 (with backoff^b)—Four Rx slots (maximum), two Tx slots (maximum), five active slots total ▪ Coding schemes—CS1–CS4 ▪ GEA1, GEA2, and GEA3 ciphering ▪ WCDMA/GERAN system selection
EDGE	<ul style="list-style-type: none"> ▪ E2 power class for 8 PSK ▪ DTM (simple class A), multislot class 12 ▪ EGPRS—Multislot class 12 (with backoff^b)—Four Rx slots (maximum), four Tx slots (maximum), five active slots total ▪ Coding schemes—MCS1–MCS9 ▪ BEP reporting ▪ SRB loopback and test modes A and B ▪ 8-bit and 11-bit RACH ▪ PBCCH support ▪ One-phase/two-phase access procedures ▪ Link adaptation and IR ▪ NACC, extended UL TBF ▪ PFC/PFI (Packet Flow Context/Packet Flow Identifier) support - allows identity tagging of RLC blocks to identify separate QoS streams at the radio link layer ▪ GPRS/EDGE MSC12-EDA - permits allocation of more than two uplink timeslots for GPRS/EDGE ▪ Enh DL RLC/MAC Segmentation - permits reception of MAC control messages that exceed one radio block capacity in length ▪ Enhanced Ext UL TBF - dummy block transmission is punctured for current saving purposes ▪ 2G PS handover - packet-switched equivalent of CS handover to ensure faster cell change and improved throughput ▪ WCDMA/GERAN ▪ Band Scan: Run-time Configurable RRC Band Scan Order ▪ Power and Network Optimizations: Frame Early Termination for Power Optimization ▪ Protocols: MRAB-Pack-1 Enhancements - reduces multi-RAB call drops ▪ GPRS/EDGE - Class 33 (296 kbps downlink, 236.8 kbps uplink) ▪ CSD (Circuit-switched data bearers) ▪ Release 4 GERAN Feature Package 1 ▪ SAIC / DARP Phase 1

Table 2-4: Supported GSM Specifications^a (Continued)

Standard	Feature Description
EDGE	<ul style="list-style-type: none"> ▪ Latency reduction ▪ Repeated FACCH, Repeated SACCH ▪ A-GPS support ▪ GPRS ROHC ▪ Enhanced Operator Name String (EONS) ▪ Enhanced Network Selection (ENS)

a. WP7607/WP7608/WP7609 only

b. Backoff is firmware dependent. 2G power backoff level is 3dB at the maximum power level as per 3GPP standards.

2.3.1.2 WCDMA Specifications

The following table describes WCDMA specifications for WP7603/WP7605/WP7607/WP7608/WP7609/WP7610/WP7611/WP7611D modules.

Table 2-5: Supported WCDMA Specifications^a

Standard	Feature Description
R99	<ul style="list-style-type: none"> ▪ All modes and data rates for WCDMA FDD, with the following restrictions: <ul style="list-style-type: none"> • The downlink supports the following specifications: <ul style="list-style-type: none"> • Up to four physical channels, including the broadcast channel (BCH), if present • Up to three dedicated physical channels (DPCHs) • Spreading factor (SF) range support from 4 to 256 • The uplink supports the following specifications: <ul style="list-style-type: none"> • One physical channel, eight TrCH, and 16 TrBks starting at any frame boundary • A maximum data rate of 384 kbps • Full SF range support from 4 to 256 ▪ PS data rates of 384 kbps DL and 384 kbps UL
R8 HSDPA	<ul style="list-style-type: none"> ▪ PS data speeds up to 42 Mbps (UE category 24) on the downlink ▪ HS-DSCH (HS-SCCH, HS-PDSCH, and HS-DPCCH) ▪ Maximum of 15 HS-PDSCH channels, both QPSK and 16 QAM modulation ▪ Support for 3GPP-defined features: <ul style="list-style-type: none"> • R99 transport channels • Maximum of four simultaneous HS-SCCH channels • CQI and ACK/NACK on HS-DPCCH channel • All incremental redundancy versions for HARQ • Configurable support for power classes 3 or 4, per TS 25.101 • TFC selection limitation on UL factoring in transmissions on the HS-DPCCH, per TS 25.133 ▪ Switching between HS-PDSCH and DPCH channel resources, as directed by the network ▪ Network activation of compressed mode by SF/2 or HLS on the DPCH for conducting inter-frequency or inter-radio access technology (RAT) measurements when the HS-DSCH is active
R8 HSDPA	<ul style="list-style-type: none"> ▪ STTD on both associated DPCH and HS-DSCH simultaneously ▪ CLTD mode 1 on the DPCH when the HS-PDSCH is active ▪ STTD on HS-SCCH when STTD or CLTD mode 1 are configured on the associated DPCH ▪ SCH-IC support ▪ HS-DSCH DRX support

Table 2-5: Supported WCDMA Specifications^a (Continued)

Standard	Feature Description
R6 HSUPA	<ul style="list-style-type: none"> ▪ E-DCH data rates of up to 5.76 Mbps for 2 ms TTI (UE category 6) uplink ▪ Support for 3GPP-defined features: <ul style="list-style-type: none"> • E-AGCH, E-RGCH, and E-HICH channels for downlink; E-RGCH and E-HICH supports serving and non-serving radio links, with up to four radio links in the E-DCH active set • All HARQ incremental redundancy versions and maximum number of HARQ retransmissions • Uplink E-DCH channel with support for up to four E-DPDCH channels • HSUPA channels run simultaneously with R99 and HSDPA channels ▪ STTD on all HSUPA downlink channels ▪ CLTD mode 1 on HS-PDSCH and DPCH along with HSUPA channels ▪ Switch between HSUPA channels and DPCH channel resources, as directed by the network ▪ Handover using compressed mode with simultaneous E-DCH and HS-DSCH interactive, background, and streaming QoS classes ▪ CSD fallback (WP7607 and WP7608) ▪ DPCCH DTX support

a. WP7603, WP7605, WP7607, WP7608, WP7609, WP7610, WP7611, WP7611D only

2.3.1.3 LTE Specifications

The following table describes LTE specifications for AirPrime WP76XX modules.

Table 2-6: Supported LTE Specifications

Standard	Feature Description
R13	<ul style="list-style-type: none"> ▪ eDRX (Extended Discontinuous Reception) to extend battery life in devices that do not require frequent network access ▪ PSM (Power Saving Mode) to reduce power consumption
R10	<ul style="list-style-type: none"> ▪ Release 10 mandatory LTE features ▪ Data rates: <ul style="list-style-type: none"> • WP7601-1, WP7603-1, WP7607-1, WP7608-1, WP7611-1, WP7611D-1—Cat 1 FDD (up to 10 Mbps downlink, 5 Mbps uplink) • WP7601, WP7603, WP7605, WP7607, WP7608, WP7609, WP7610, WP7611, WP7611D—Cat 4 FDD (up to 150 Mbps downlink, 50 Mbps uplink) ▪ 1.4 MHz, 3 MHz, 5 MHz, 10 MHz, 15 MHz and 20 MHz RF bandwidth ▪ IPv6, QoS ▪ Inter-RAT capabilities with HSPA+ (WP7603, WP7605, WP7607, WP7608, WP7609, WP7610, WP7611, WP7611D only) ▪ NAS & RRC standalone security

Table 2-6: Supported LTE Specifications (Continued)

Standard	Feature Description
R10	<ul style="list-style-type: none"> ▪ Commercial Mobile Alert System (CMAS) ▪ ETWS (Earthquake Tsunami Warning System) notification ▪ Inter-frequency/bandwidth mobility ▪ DRX cycle while in: <ul style="list-style-type: none"> ▪ Connected mode ▪ Idle mode ▪ UE IRAT support for Self Organizing Networks and Automatic Neighbor Relation (SON AR) ▪ Mode reselections: <ul style="list-style-type: none"> ▪ LTE ↔ GERAN Idle mode mobility (cell reselection) ▪ LTE ↔ UMTS Idle mode mobility (cell reselection) ▪ Mode redirections: <ul style="list-style-type: none"> ▪ UMTS to LTE redirections <ul style="list-style-type: none"> ▪ Blind redirection ▪ Based on measurements during WCDMA compressed mode gaps ▪ GERAN to LTE redirections (blind; no measurements) ▪ LTE to UMTS redirections (with measurements on UMTS) ▪ LTE to UMTS PS Handover ▪ LTE/GW Data Silent Redial for InterRAT ▪ Attach/detach PS during Voice Call or SMS ▪ WCDMA fallback (WP7603, WP7605, WP7607, WP7608, WP7609, WP7610, WP7611, WP7611D only)
System Determination	<ul style="list-style-type: none"> ▪ Frequency Scan and System Selection within LTE ▪ LTE BPLMN support ▪ LTE Connected mode OOS ▪ System selection across RATs, Standalone Security, Dedicated EPS Bearer Management and Dormancy ▪ System selection across LTE, UMTS (WP7603, WP7605, WP7607, WP7608, WP7609, WP7610, WP7611, WP7611D only), GERAN ▪ 256 UPLMN and 256 OPLMN entries in UIM support ▪ Carrier Specific BSR Requirements
Data	<ul style="list-style-type: none"> ▪ Data call throttling ▪ Default IPv4 bearer activation at attach/IPv4 data call ▪ NW and UE initiated QoS ▪ Dual IP and IPv4/IPv6 continuity ▪ IPv4/IPv6 session continuity ▪ W/G IP session continuity ▪ Emergency services — LTE NAS Support for Control Plane LTE Positioning Protocol

2.3.2 Modem Specifications

Table 2-7: Supported Modem Specifications

Standard	Feature Description
Data	<ul style="list-style-type: none">▪ IPHC protocol as RFC 2509▪ Stateless DHCPv4 protocol to get P-CSCF and DNS addresses▪ IPv4/IPv6▪ Dual IP on single QMAP PDN▪ Multi-QMAP PDN Data Call

2.4 Multi-Core Processing Capabilities

The AirPrime WP76XX is a powerful multiple-core system that includes:

- One QDSP6 core, embedding Telecom firmware with integrated cellular voice (WCDMA), VoLTE, data and wireless Internet connectivity
- One Cortex A7 core entirely dedicated to customer application and natively provided with Linux operating system

3: Technical Specifications

3.1 Environmental

The environmental specifications for operation and storage of the AirPrime WP76XX are defined in Table 3-1.

Table 3-1: Environmental Specifications

Parameter	Range	Operating Class
Ambient Operating Temperature	-30°C to +70°C	Class A
	-40°C to +85°C	Class B
Ambient Storage Temperature	-40°C to +85°C	-
Ambient Humidity	95% or less	-

Class A is defined as the operating temperature range within which the device:

- Shall exhibit normal function during and after environmental exposure.
- Shall meet the minimum requirements of 3GPP or appropriate wireless standards.

Class B is defined as the operating temperature range within which the device:

- Shall remain fully functional during and after environmental exposure
- Shall exhibit the ability to establish any of the device's supported call modes (SMS, Data, and emergency calls) at all times even when one or more environmental constraint exceeds the specified tolerance.
- Unless otherwise stated, full performance should return to normal after the excessive constraint(s) have been removed.

3.2 Power Supply Ratings

The AirPrime WP76XX operates using DC power supplied via the VBAT_RF and VBAT_BB signals. Power supply options are:

- (Recommended) A single regulated DC power supply (3.7V nominal)
- Two regulated DC power supplies (3.7V nominal), one each for VBAT_BB and VBAT_RF

Note:

- *Operation above the maximum specified operating voltage (see [Table 3-3](#) on page 32) is not recommended, and specified typical performance or functional operation of the device is neither implied nor guaranteed.*
- *Proper operation is not guaranteed or recommended for USB_VBUS as the main power supply.*

Table 3-2: Power Supply Pins

Pin	Name	Direction	Function	Notes
63, 158	VBAT_BB	Input	Baseband power supply	63 — Must be used 158 — Optional
61, 62, 157	VBAT_RF	Input	RF power supply	61/62 — Must be used 157 — Optional

Table 3-3: Operating Conditions

Parameter	Min	Typ	Max	Units	Notes	
Power supply voltage ^{a,b}	3.4	3.7	4.3	V	Must be within min/max values over all operating conditions (including voltage ripple, drop, and transient).	
Power supply ripple	-	-	100	mV _{pp}	See Figure 3-1 on page 32.	
Power supply voltage drop	-	-	250 ^c	mV	See Figure 3-1 on page 32 and Under-Voltage Lockout (UVLO) on page 33.	
Power supply voltage transient (overshoot/undershoot)	-	-	300 ^c	mV	See Figure 3-1 on page 32.	
Supply current	LTE, UMTS	-	0.8	1.5	A	<ul style="list-style-type: none"> Typical value varies and depends on output power, band, and operating voltage. See Current Consumption on page 43 for values measured under normal operating conditions. Max value measured over 100 μs period.
	GSM	-	1.0	3.0 ^d	A	

- a. Power supply voltage outside the required range may affect call quality (dropped calls, data transfer errors, etc.)
- b. For Absolute Maximum Ratings, see [Table 3-56](#) on page 69.
- c. Values to be confirmed for WP7607 / WP7609
- d. Recommended rated current of the power supply.

Customer should characterize the ripple, drop, and transient response (overshoot/undershoot) of the power supply delivery system at the module input under full transmit power in GSM mode if supported, or LTE mode if not. To minimize voltage variation, add suitable capacitors to the supply line as close as possible to the module — depending on the power supply design, these capacitors may range from tens to several thousand μF.

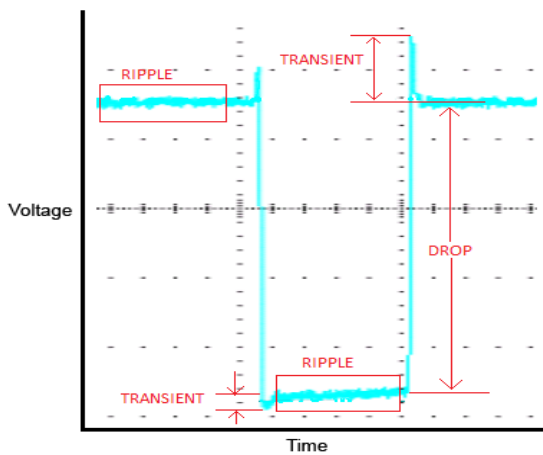


Figure 3-1: Power Supply Characteristics (capture enlarged)

3.2.1 Under-Voltage Lockout (UVLO)

The power management section of the AirPrime WP76XX includes an under-voltage lockout circuit that monitors supply and shuts down when VBAT_BB falls below the threshold.

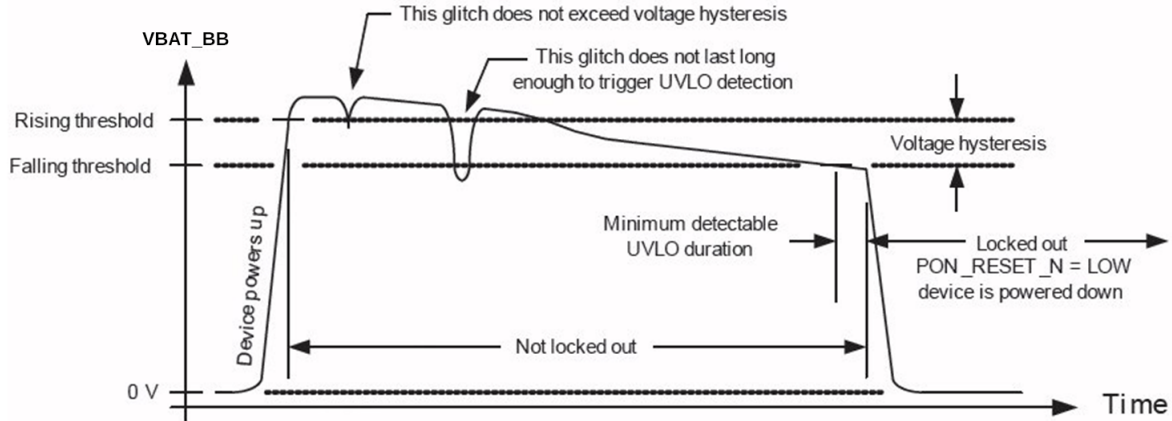


Figure 3-2: Under-Voltage Lockout (UVLO) Diagram

The AirPrime WP76XX will power down and remain off until VBAT_BB returns to the valid range and the ON/OFF signal is active.

Note: If the device experiences six consecutive UVLO events less than 45 seconds apart (approximately) and a host-initiated power down or reset has not occurred, the device enters a mode in which only the DM port enumerates on the USB.

Table 3-4: UVLO Specifications

Parameter	Min	Typ	Max	Units
Threshold voltage, falling	2.225	2.4	2.80	V
Threshold voltage, accuracy	-5	-	+5	%
Hysteresis	-	425	-	mV
UVLO detection interval	-	1.0	-	μs

3.2.2 Power Consumption States

The AirPrime WP76XX has four basic power states (Active, Sleep, Ultra Low Power State (ULPS), and Off). As the module transitions between power states, the range of available device functionality adjusts appropriately, as described in Table 3-5 on page 34 and Figure 3-3 on page 37.

In the Active state, the module is ON with the application processor running. In Sleep state, the processor suspends its activity, reducing power consumption. The Active and ULPS states have more than one power mode each, to reduce power consumption. ULPS supports both Power Saving Mode (PSM, network-dependent) and Ultra Low Power Mode (ULPM), which may be enabled to achieve the lowest possible average power consumption.

Table 3-5: Supported Power States

State	Description
Active	<p>Module is fully powered (Linux can be run in the Application Core; modem is on) and operating in one of the following modes:</p> <ul style="list-style-type: none"> ▪ Full function (WWAN radio active; GNSS radio can be turned on/off) — Highest power consumption. ▪ Idle mode (WWAN radio on; Module registered on network, but no active connection; GNSS radio can be turned on/off) ▪ Airplane mode (WWAN radio off; GNSS radio can be active if allowed by PRI) ▪ eDRX (Extended Discontinuous Reception)—eDRX mode provides a ‘flexible sleep’ for the modem, which significantly reduces energy consumption. For eDRX details, see Extended Discontinuous Reception (eDRX) on page 41.
Sleep	<p>Lower power consumption than Active state, but higher than ULPS.</p> <ul style="list-style-type: none"> ▪ Application Core is sleeping; modem is in DRX/eDRX. The processor monitors signals (triggers) that can ‘wake’ the module—see Wakeup Interrupt (Sleep State) on page 90 for details. <p>Sleep state can be entered based on USB-SS (if USB is connected to the module), UART_DTR, wake_lock(), configured GPIOs, and QMI exchanges from the modem.</p> <p>To further minimize sleep mode current consumption, it is recommended to disable HSIC using AT!CUSTOM="HSICENABLE",00 if the HSIC bus is not used.</p> <p><i>Note: On Windows systems, due to limitations of the Windows ECM driver, Sleep state is only supported if ECM is disabled or USB is disconnected.</i></p>

Table 3-5: Supported Power States (Continued)

State	Description
Ultra Low Power State (ULPS)	<p>ULPS is entered through either ULPM or PSM, and enables the module to attain its lowest power consumption by turning off the Application Core processor (no applications will run) while waiting for wakeup sources ('boot sources'). When the module wakes from ULPS, the module reboots into the Active state.</p> <p>AUIs (Legato, Linux sysfs, and AT interface) are available to:</p> <ul style="list-style-type: none"> • Configure wakeup sources (also known as boot sources) • Select ULPM, PSM, or PSM with ULPM fallback (when PSM is not supported by the network) <p><i>Note: Some configuration options are not available in different AUIs (e.g. AT/sysfs allow selection of PSM, ULPM, and PSM with ULPM fallback, while Legato supports only PSM with ULPM fallback).</i></p> <p>Once a module is in ULPS, it remains in this state until woken by a wakeup source (see Table 3-6 on page 36).</p> <p>ULPS current consumption varies depending on configured triggers. For example, the lowest consumption occurs when the processor is waiting only for a timer (approximately 6 ?A), and the highest consumption occurs when all supported triggers are configured.</p> <p><i>Note: Current consumption in both ULPM and PSM modes will be similar.</i></p> <p>For details on configuring ULPM, and how the module transitions between Active and ULPM states, see Current Consumption on page 43.</p>
	<p>Ultra Low Power Mode (ULPM)</p> <p><i>Note: ULPM is only available for Group A variants.</i></p> <p>ULPM is an operational mode that allows the module to enter ULPS without any dependency on network support. This is when the module is operating at its lowest power state. All subcomponents of the module are powered off except the on-board MCU for user-configurable wake-up triggers (timer, GPIO or ADC). At this mode, all other communication interfaces are disabled.</p> <p>AUIs (Legato, Linux sysfs, and AT interface) are first used to configure wakeup sources. Then, when the application uses an AUI to enable ULPM, the module detaches from the network (if currently attached) and enters ULPS.</p> <p>When a wakeup source triggers exit from ULPS, the modem and application processors boot up and the module reattaches to the network to resume operation in Active state until ULPM is again enabled by the application.</p> <p><i>Note: All interfaces connected to the module's GPIOs (see Table 4-7 on page 88) must be tri-stated or off to prevent additional leakage current during ULPM and potentially damaging the unit by applying a voltage when the GPIOs are off.</i></p>
	<p>LTE Power Saving Mode (PSM)</p> <p>3GPP Release 12 introduced network support of PSM. PSM allows the module to negotiate, with the network, an extended period during which registration context with the network is retained while the module is unreachable. During the negotiated period, the module enters ULPS.</p> <p>When a wakeup source triggers exit from ULPS, the modem and application processors boot up and the module sends a TAU (Tracking Area Update) to the network.</p> <p>After sending the TAU, the module remains active to allow any pending data to be exchanged with the network. Then, after a negotiated period of inactivity, the module automatically returns to ULPS to repeat the PSM cycle.</p> <p><i>Note: Wakeup sources are retained across PSM cycles, but may be changed by the application during the active period, if desired.</i></p> <p>For PSM details, see Power Saving Mode (PSM) on page 38.</p>

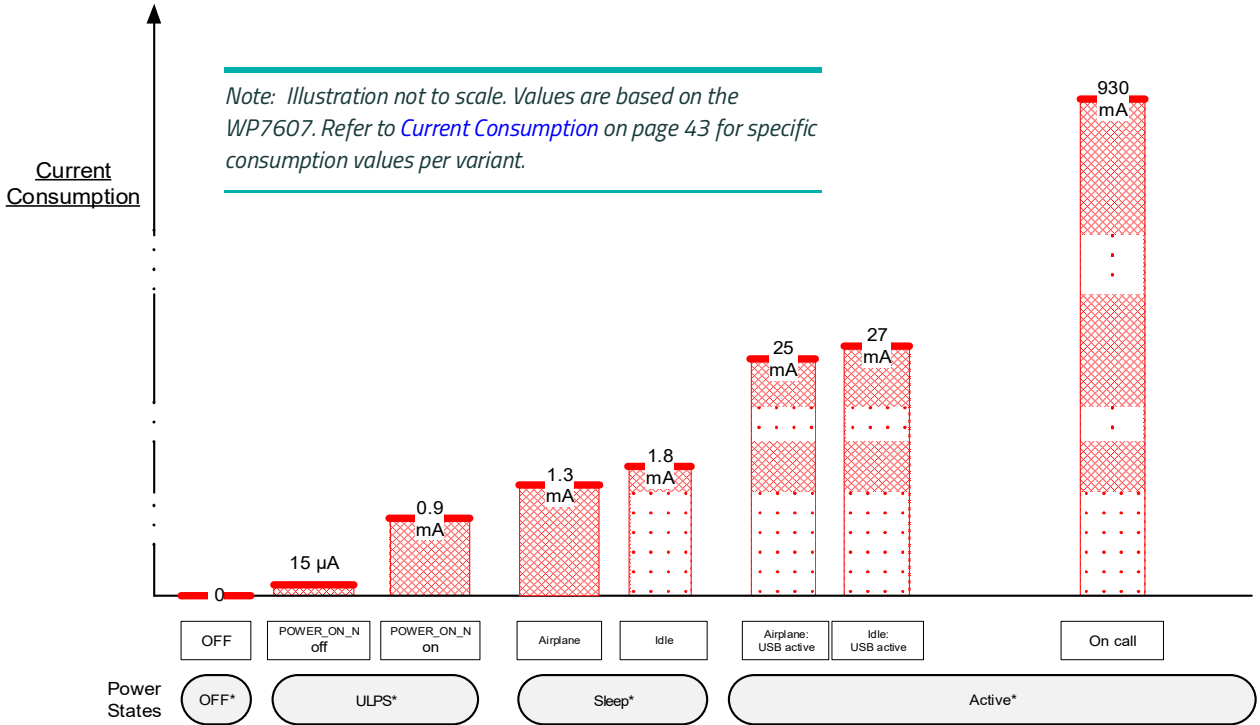
Table 3-5: Supported Power States (Continued)

State	Description
	<p>Comparison — PSM vs. ULPM</p> <p>PSM differs from ULPM in the following ways:</p> <ul style="list-style-type: none"> PSM is network-dependent (network must support 3GPP PSM), with a repeating cycle of an Active period and an inactive period, managed by the telecom stack. ULPM is network-independent, and each entry to ULPS is controlled by the application. PSM is subject to timer values negotiated with the network, including a 'TAU' wakeup timer (initially set by the module, then negotiated with and agreed to be the network) that is automatically managed by the telecom stack. ULPM may remain in ULPS indefinitely, waiting for non-time-based wakeup sources. In PSM, networking layer signaling overhead is reduced and context (such as IP address) is retained. Application data coming (downlink) from the network is queued for the next active period. Note that the processor can be woken by a wakeup source during the inactive period to send data without needing to reattach to the network. In PSM, radio resource signaling is reduced—TAU requires much less radio signaling than ULPM detach/reattach.
OFF	<p>Module is OFF (no power to the system). Apply power for system to go to:</p> <ul style="list-style-type: none"> Active state (POWER_ON_N is asserted) or ULPS (POWER_ON_N is de-asserted)

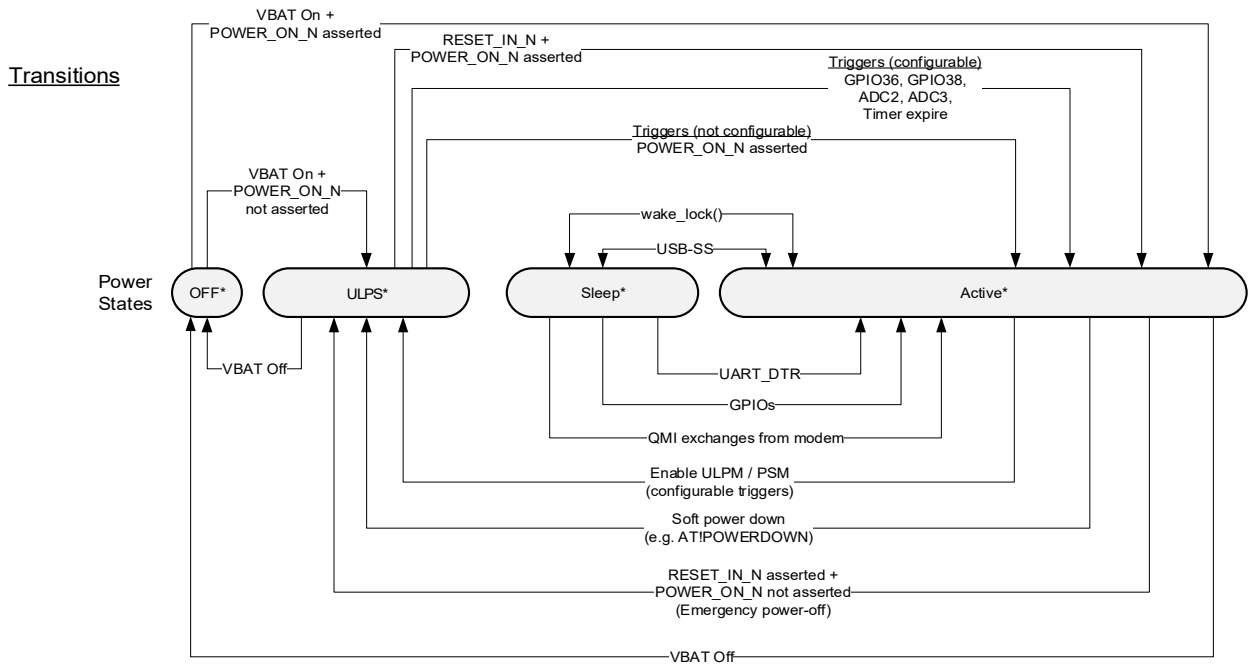
Table 3-6: ULPS Wakeup Sources

Type	Description
PSM TAU timer	<p>Periodic TAU—PSM Cycle Timer (T3412) Configurable timer specifying PSM sleep duration. See Table 3-8 on page 39 for configuration methods. Applies to PSM only.</p>
ULPS wakeup timer	<p>Timer that triggers after a specified period.</p> <ul style="list-style-type: none"> ULPM—Optional PSM—Derived from TAU timer (value is automatically set slightly shorter than TAU timer to ensure module boot completes before TAU timer expires)
ADC interrupt	<p>ADCs (ADC2, ADC3) configured for asynchronous wakeup of module. ADCs may be configured to trigger on threshold (above/below; e.g. wake on ADC2 above 1.2V) or range (inside/outside; e.g. wake when value is inside a specified range, or outside a specified range). Applies to both ULPM and PSM.</p>
GPIO interrupt	<p>Interrupt-capable GPIOs (GPIO36, GPIO38) configured for asynchronous wakeup of module. GPIOs may be configured to trigger on level transition (high/low) or edge transition (rising/falling/both). Applies to both ULPM and PSM.</p>
RESET_IN_N	<p>Resets the module with POWER_ON_N ON. Applies to both ULPM and PSM.</p> <p><i>Note: If RESET_IN_N is used when POWER_ON_N is OFF, an emergency power off occurs—see Emergency Power Off on page 83.</i></p>
POWER_ON_N	<p>Wakes the module when asserted (transitions from OFF to ON). Applies to both ULPM and PSM.</p>

Figure 3-3 on page 37 illustrates the current consumption requirements of the different power states and the possible transitions between power states. For specific values, see module-specific current consumption tables in [Current Consumption](#) on page 43.



* Refer to [Table 3-5](#) on page 34 for Power State definitions.



Note: VBAT = VBAT_BB and VBAT_RF

Figure 3-3: Power State Transitions

3.2.3 Power Saving Mode (PSM)

Power Saving Mode (PSM) is a 3GPP feature that allows the WP76xx to minimize power consumption by registering on a PSM-supporting LTE network, entering ULPS (a very low power 'dormant' state) for a pre-configured duration (via a periodic TAU (Tracking Area Update) timer), and then booting up for a short period to transmit/receive data, before re-entering ULPS. During the dormant period, the module remains unreachable by the network until woken by a configured wakeup source (timer, ADC, GPIO, POWER_ON_N, RESET_IN_N) or the expiry of the periodic TAU timer.

Note: When using PSM, the POWER_ON_N signal must be floating. If this signal is grounded, it will automatically trigger a wake.

Note: Simplified current consumption pattern to illustrate general structure of PSM cycle power state transitions.

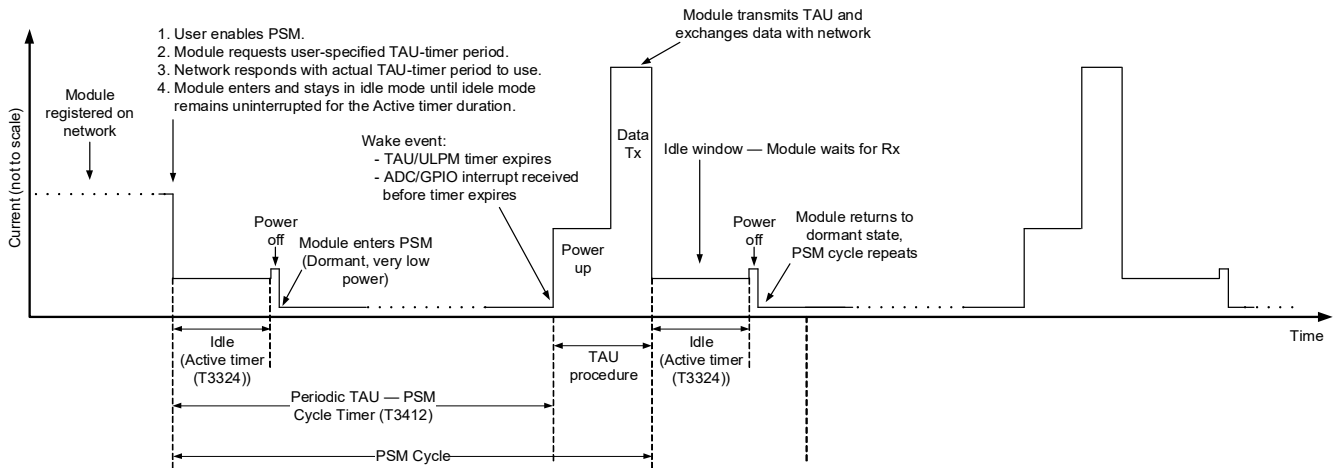


Figure 3-4: PSM Example (Simplified)

The following table describes different PSM configuration options available. By default, WP76xx modules are configured to option B, with options A and C reserved for debug purposes.

Table 3-7: PSM Configuration Options

Option	Description
A	<ul style="list-style-type: none"> MCU I2C is always on during PSM, waiting for MDM message MDM RTC alarm is used as the timer wakeup source
B	<ul style="list-style-type: none"> MCU I2C is only on near the end of PSM, waiting for MDM message MDM RTC alarm is used as the timer wakeup source
C	<ul style="list-style-type: none"> MCU I2C is on at the end of PSM MCU RTC alarm is used as the timer wakeup source MDM is completely powered off <p><i>Note: PSM does not work with option C in the latest Firmware release.</i></p>

Typical candidates for PSM are systems (such as monitors and sensors) that:

- Require long battery life (low power consumption)
- Tolerate very long latency for mobile-terminated SMS/data
- Do not use mobile-terminated voice

- Send and/or receive data infrequently and periodically (e.g. on a given schedule of once every few hours, days, weeks, etc.)

For example, a module connected to a sensor can be configured to:

- Wake periodically to transmit collected data to a server or network entity (e.g. once per week schedule, or when a sensor activates an ADC interrupt due to an out-of-range reading), then
- Wait a short (configured) period of time to receive transmissions (e.g 60 seconds) and then return to its dormant state.

Table 3-6 describes the available triggers for waking a WP76xx from ULPS. These triggers are configured using the methods described in Table 3-8.

Table 3-8: ULPS-Related Application User Commands/Interfaces

Type	Command ^a /Interface	Description
AT	+CPSMS	<p>3GPP-defined command (3GPP TS27.007 Release 12) that allows direct control of all LTE PSM parameters, and is useful for advanced users wanting to test/experiment with different options. This command is limited to networks that support PSM.</p> <p>It is not expected that every user must be fully versed in the details of PSM to take advantage of its capabilities.</p> <p>Use this command to:</p> <ul style="list-style-type: none"> ▪ Enable/disable LTE PSM. ▪ Configure Period TAU timer (T3412) with a requested maximum duration of the dormant period. ▪ Configure Active timer (T3324) with a requested 'idle mode time' (the duration the module remains idle before going dormant) ▪ For usage details, refer to [1] AirPrime WP8548/WP75xx/WP76xx/WP77xx AT Command Reference. (This command follows the 3GPP TS 27.007, Release 12 specification, with exceptions noted for certain parameters.) <p><i>Note: The requested timer values are negotiated with the network and the final negotiated values take effect immediately, then persist across power cycles (e.g. after a power cycle, the settings will be used during network attach).</i></p>
	!POWERMODE	<p>Custom Semtech command that allows application developers to simplify the harmonization of PSM and ULPM without needing to consider whether PSM is supported on the network to which the WP module is currently attached.</p> <p>The command can be used to select the power mode (ULPM, PSM, PSM with ULPM fallback).</p> <p><i>Note: The Legato ULPM API provides equivalent functionality.</i></p>
	!POWERWAKE	<p>Custom Semtech command used to configure the wakeup sources for both PSM and ULPM, such as GPIOs, ADCs, and ULPS timer.</p> <p><i>Note: The Legato ULPLM API provides equivalent functionality.</i></p>
	<p>Important: Semtech recommends not combining use of +CPSMS and !POWERWAKE. These commands have some functional overlap, which may result in unexpected effects.</p>	
API	<p>Legato Power Services:</p> <ul style="list-style-type: none"> ▪ Power Manager ▪ Ultra Low Power Mode ▪ Boot Reason Query 	<p>Legato APIs and Linux sysfs nodes are available to configure and enable the feature.</p>

- a. For AT command details, refer to [1] AirPrime WP8548/WP75xx/WP76xx/WP77xx AT Command Reference, available from the device's page on source.sierrawireless.com.
For API library function details, refer to docs.legato.io/latest/legatoServicesPowerMain.html.

Example: PSM Process

The following example describes how the module uses PSM (as shown in [Figure 3-4](#) on page 38):

1. Module registers on an LTE network.
2. User enables PSM via AT command or API library function, specifying the desired TAU timer and Active timer periods, and optional wakeup sources.
3. Module submits the PSM request (including desired TAU timer) to the network.
4. Network responds and indicates whether PSM is supported and (if it is) indicates the actual TAU timer to use.
5. If the network supports PSM:
 - a. Module enters idle mode (waiting for Rx from network).
 - b. When module has remained idle for the Active timer period, module powers off (except for maintaining timer and interrupts) and enters ULPS.
 - c. Module remains in ULPS for the specified period or until a configured trigger (ADC or GPIO interrupt, POWER_ON_N, RESET_IN_N) wakes it.

Note: If traffic must be transmitted when the module is in the sleep portion of the cycle, the module can initiate data/SMS/voice session immediately.

- d. Module powers up before TAU timer expires, then transmits TAU and/or exchanges data with network.
- e. Module enters idle mode and cycle repeats.

Note: When the module is powered up, the PSM request can be re-issued with different timers and triggers to adjust the PSM behavior. These new settings take effect immediately.

Important Notes

- Carefully select the PSM Periodic-TAU timer and Active Time values to match the intended use case(s) for the module:
 - Periodic TAU PSM Cycle timer (T3412)—Note that while the module is dormant (for the duration of this timer, unless woken by a user-configured ADC or GPIO interrupt, or POWER_ON_N or RESET_IN_N), it will be completely unreachable by the network.
 - Active Time (Idle mode time after transmission (T3324))—Make sure to set the Active timer high enough to provide appropriate delay-tolerance for mobile-terminated / network-originated transmissions to be received.
- When using multiple devices, consider scheduling the modules to wake at different times so that the network does not get flooded by all modules waking and transmitting simultaneously.

3.2.4 Active State to ULPS Transition

If the module will be used in situations where it needs to be active very infrequently (for example, in a remote monitoring station that must transmit data periodically—e.g. on a regular schedule ranging from days to weeks or more), Ultra Low Power Mode (ULPM) or PSM (Power Saving Mode) may be used to reduce power consumption much more than is possible in Sleep state (low power active state):

1. Configure one or more supported wakeup sources that the processor will monitor while the module is in ULPS. See [Table 3-6](#) on page 36.

Note: Wakeup source configurations are persistent — if the module enters ULPS and then returns to Active power state, the configured triggers remain in effect.

2. Initiate ULPM or PSM. The module will enter ULPS unless one or more of the configured wakeup sources is currently triggered. If the module does not enter ULPS, the request must be explicitly repeated—the module will not attempt to enter ULPS automatically.

3.2.5 Extended Discontinuous Reception (eDRX)

The WP76xx supports eDRX, which is a ‘flexible sleep’ active mode that allows for longer sleep duration (T_{C-eDRX} , T_{I-eDRX}) and a significant decrease in power consumption compared to regular DRX (T_{C-DRX} , T_{I-DRX}).

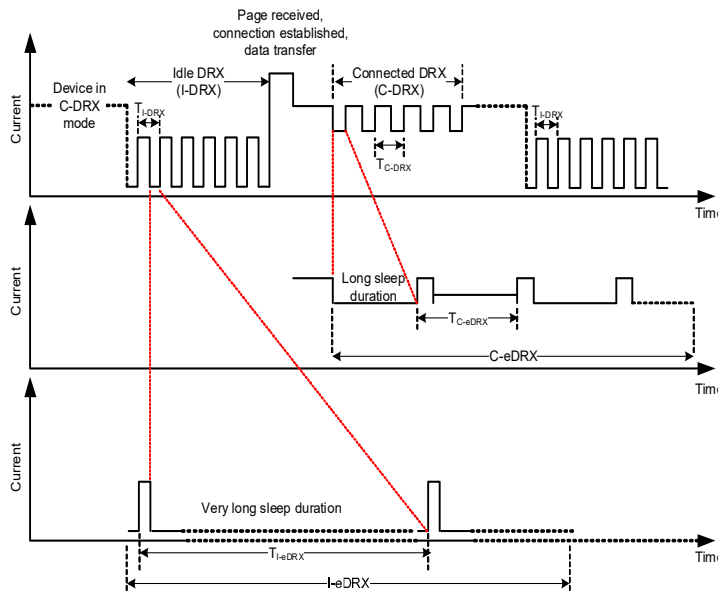


Figure 3-5: eDRX Example (Simplified)

Specifically, the WP76xx supports two forms of eDRX, both of which extend the DRX cycle (the paging cycle comprised of a paging window during which the module is awake and able to receive or transmit on the network, and a sleep period during which the network cannot wake the module) by increasing the sleep duration beyond the DRX maximum of 2.56 seconds:

- I-eDRX (Idle mode eDRX) — The sleep duration of the DRX cycle can be set up to 44 minutes for LTE-M. Note that I-eDRX has wider network support than C-eDRX.
- C-eDRX (Connected mode eDRX) — The sleep duration of the DRX cycle can be set up to 10 seconds.

Note: If traffic must be transmitted when the module is in the sleep portion of the cycle, the module can initiate data/SMS/voice session immediately.

Table 3-9 describes the available methods for configuring eDRX.

Table 3-9: eDRX-Related Commands^a

Type	Command	Description
AT	+CEDRXS	Enable/disable eDRX, and configure related settings
AT	+CEDRXRDP	Display current eDRX settings
API	le_lpt_SetEDrxState()	Enable/disable eDRX
API	le_lpt_SetRequestedEDrxValue()	Set eDRX cycle length for a specified RAT
API	le_lpt_GetRequestedEDrxValue()	Get eDRX cycle length for a specified RAT
API	le_lpt_GetNetworkProvidedEDrxValue()	Get eDRX cycle length provided by the network.
API	le_lpt_GetNetworkProvidedPagingTimeWindow()	Get the paging window provided by the network (Note: the paging window cannot be set by the module.)
API	le_lpt_AddEDrxParamsChangeHandler()	Set notifications for changes in network-provided eDRX parameters
API	le_lpt_RemoveEDrxParamsChangeHandler()	Remove the handler.

- a. For AT command details, refer to [1] AirPrime WP8548/WP75xx/WP76xx/WP77xx AT Command Reference from the device's page on source.sierrawireless.com. For API command details, refer to the latest Legato Release Notes at legato.io/legato-docs/latest/c_mrc.html.

Example: eDRX Process

- Use the AT+CEDRXS command to configure the desired eDRX behavior.
- During the network attachment process:
 - eDRX request and settings are sent to the network
 - Network responds and indicates whether eDRX is supported for the connection and may adjust the eDRX parameters.
- If eDRX is supported by the network:
 - While in active mode (connected), the C-eDRX sleep duration is used if supported, otherwise the regular DRX sleep duration is used.
 - While in idle mode, the I-eDRX sleep duration is used if supported, otherwise the network uses the standard LTE I-DRX value.

Important Notes

- The sleep duration must be carefully selected to match the intended use case(s) for the module. While the module is asleep, it will be unreachable by the network. The duration should provide appropriate delay-tolerance for mobile-terminated/network-originated transmissions to be received.
- Due to the extended sleep time compared to regular DRX, eDRX is not suitable for most mobile-terminated voice connections.
- Network-side store and forward is supported — Packets will be stored until the module is reachable.

3.2.6 Current Consumption

The following tables describe the AirPrime WP76XX modules' current consumption under various power states. Typical values are measured at nominal supply voltage, nominal ambient temperature, and with a conducted 50Ω load on the antenna port.

Table 3-10: WP7601 Current Consumption Values

Mode	Parameter	Min	Typ ^a	Max ^b	Units
Power state — Active					
LTE Data transfer ^c	B4	175	655	860	mA
	B13	140	500	725	mA
Idle — LTE	<ul style="list-style-type: none"> ▪ Registered ▪ Paging cycle=256 ▪ USB active 	23	23.5	25	mA
Airplane mode	<ul style="list-style-type: none"> ▪ Radio off ▪ USB active 	21	22	24	mA
Power state — Sleep					
Idle — LTE	<ul style="list-style-type: none"> ▪ Registered ▪ Paging cycle=256 ▪ USB-SS 	1.6	1.7	1.8	mA
Idle — LTE eDRX	Period = 40 sec	0.9	1	1.2	mA
Airplane mode	<ul style="list-style-type: none"> ▪ Radio off ▪ USB-SS 	0.8	0.85	0.9	mA
Power state — ULPS					
Ultra Low Power Mode (ULPM)	See Table 3-17 on page 52 for details.				
Power Saving Mode (PSM)	Non-active	21	21.5	22	μA

Table 3-10: WP7601 Current Consumption Values (Continued)

Mode	Parameter	Min	Typ ^a	Max ^b	Units
GNSS ^d					
GNSS	Acquisition (Airplane mode, cold start)	23	25	35	mA
	Tracking (Registered)	23	25	35	mA

- a. Typical, measured at nominal temperature, nominal voltage.
- b. Worst case transmit values measured at 70°C, 3.4V. Worst case idle mode values measured at room temperature, 3.7V.
- c. Min value at LTE conducted min Tx output power; Typ/Max values at LTE conducted max Tx output power (see Table 3-36 on page 58)
- d. GNSS current consumption values are for the GNSS radio only. For total consumption, add the GNSS value to the consumption for the mode being used.

Table 3-11: WP7603 Current Consumption Values

Mode	Parameter	Min	Typ ^a	Max ^b	Units
Power state — Active					
HSDPA data transfer ^c	B2	130	585	750	mA
	B4	130	560	700	mA
	B5	115	440	585	mA
LTE Data transfer ^d	B2	175	730	930	mA
	B4	175	700	870	mA
	B5	140	480	695	mA
	B12	140	555	820	mA
Idle — WCDMA	<ul style="list-style-type: none"> ▪ Registered ▪ DRX=8 ▪ USB active 	20	24	27	mA
Idle — LTE	<ul style="list-style-type: none"> ▪ Registered ▪ Paging cycle=256 ▪ USB active 	23	23.5	25	mA
Airplane mode	<ul style="list-style-type: none"> ▪ Radio off ▪ USB active 	21	22	24	mA
Power state — Sleep					
Idle — WCDMA	<ul style="list-style-type: none"> ▪ Registered ▪ DRX=8 ▪ USB-SS 	1.2	1.3	1.4	mA
Idle — LTE	<ul style="list-style-type: none"> ▪ Registered ▪ Paging cycle=256 ▪ USB-SS 	1.6	1.7	1.8	mA
Idle — LTE eDRX	Period = 40 sec	0.9	1	1.2	mA

Table 3-11: WP7603 Current Consumption Values (Continued)

Mode	Parameter	Min	Typ ^a	Max ^b	Units
Airplane mode	<ul style="list-style-type: none"> ▪ Radio off ▪ USB-SS 	0.8	0.85	0.9	mA
Power state — ULPS					
Ultra Low Power Mode (ULPM)	See Table 3-17 on page 52 for details.				
Power Saving Mode (PSM)	Non-active	21	21.5	22	µA
GNSS ^e					
GNSS	Acquisition (Airplane mode, cold start)	23	25	35	mA
	Tracking (Registered)	23	25	35	mA

- a. Typical, measured at nominal temperature, nominal voltage.
- b. Worst case transmit values measured at 70°C, 3.4V. Worst case idle mode values measured at room temperature, 3.7V.
- c. At WCDMA conducted max Tx output power (see [Table 3-22](#) on page 54)
- d. Min value at LTE conducted min Tx output power; Typ/Max values at LTE conducted max Tx output power (see [Table 3-37](#) on page 58)
- e. GNSS current consumption values are for the GNSS radio only. For total consumption, add the GNSS value to the consumption for the mode being used.

Table 3-12: WP7605 Current Consumption Values

Mode	Parameter	Min	Typ ^a	Max ^b	Units
Power state — Active					
HSDPA Data transfer ^c	B1	140	610	880	mA
	B6	140	560	770	mA
	B19	130	580	820	mA
LTE Data transfer ^d	B1	220	620	800	mA
	B3	220	650	830	mA
	B8	200	700	930	mA
	B11	200	560	820	mA
	B18	210	590	760	mA
	B19	210	590	730	mA
	B21	200	560	730	mA
Idle — WCDMA	<ul style="list-style-type: none"> ▪ Registered ▪ DRX=8 ▪ USB active 	25	26	39	mA
Idle — LTE	<ul style="list-style-type: none"> ▪ Registered ▪ Paging cycle=256 ▪ USB active 	25	26	39	mA

Table 3-12: WP7605 Current Consumption Values (Continued)

Mode	Parameter	Min	Typ ^a	Max ^b	Units
Airplane mode	<ul style="list-style-type: none"> ▪ Radio off ▪ USB active 	23	25	36	mA
Power state — Sleep					
Idle — WCDMA	<ul style="list-style-type: none"> ▪ Registered ▪ DRX=8 ▪ USB-SS 	1.1	1.2	6.0	mA
Idle — LTE	<ul style="list-style-type: none"> ▪ Registered ▪ Paging cycle=256 ▪ USB-SS 	1.3	1.5	6.0	mA
Idle — LTE eDRX	Period = 40 sec	1.1	1.2	3.8	mA
Airplane mode	<ul style="list-style-type: none"> ▪ Radio off ▪ USB-SS 	0.9	1.0	4.0	mA
Power state — ULPS					
Ultra Low Power Mode (ULPM)	Not supported				
Power Saving Mode (PSM)	Non-active	14.3	14.5	27.5	µA
GNSS ^e					
GNSS ^f	Acquisition (Airplane mode, cold start)	23	25	35	mA
	Tracking (Registered)	23	25	35	mA

- a. Typical, measured at nominal temperature, nominal voltage.
- b. Worst case, measured at 70°C, 3.4V.
- c. At WCDMA conducted max Tx output power (see [Table 3-23](#) on page 54)
- d. At LTE conducted max Tx output power (see [Table 3-38](#) on page 58)
- e. GNSS support is SKU-dependent.
- f. GNSS current consumption values are for the GNSS radio only. For total consumption, add the GNSS value to the consumption for the mode being used.

Table 3-13: WP7607 and WP7609 Current Consumption Values

Mode	Parameter	Min	Typ ^a	Max ^b	Units
Power state — Active					
GSM/GPRS/EDGE data transfer	E-GSM 900	160	600	2160 ^c 1020 ^d	mA
	DCS 1800	150	560	1278 ^c 665 ^d	mA
HSDPA data transfer ^e	B1	180	803	1140	mA
	B5 ^f	170	590	860	mA
	B8	150	550	840	mA

Table 3-13: WP7607 and WP7609 Current Consumption Values (Continued)

Mode	Parameter	Min	Typ ^a	Max ^b	Units
LTE Data transfer ^g	B1	240	790	850	mA
	B3	240	740	900	mA
	B5 ^f	210	750	850	mA
	B7	300	770	980	mA
	B8	210	620	700	mA
	B20 ^h	210	750	850	mA
	B28	210	670	710	mA
Idle—GSM/GPRS/EDGE	<ul style="list-style-type: none"> ▪ Registered ▪ MFRM=9 ▪ USB active 	25	25	36	mA
Idle—WCDMA	<ul style="list-style-type: none"> ▪ Registered ▪ DRX=8 ▪ USB active 	25	25	36	mA
Idle—LTE	<ul style="list-style-type: none"> ▪ Registered ▪ Paging cycle=256 ▪ USB active 	25	26	39	mA
Airplane mode	<ul style="list-style-type: none"> ▪ Radio off ▪ USB active 	25	25	36	mA
Power state—Sleep					
Idle—GSM/GPRS/EDGE	<ul style="list-style-type: none"> ▪ Registered ▪ MFRM=9 ▪ USB-SS 	1.7	1.8	4	mA
Idle—WCDMA	<ul style="list-style-type: none"> ▪ Registered ▪ DRX=8 ▪ USB-SS 	1.6	1.8	4	mA
Idle—LTE	<ul style="list-style-type: none"> ▪ Registered ▪ Paging cycle=256 ▪ USB-SS 	1.7	1.8	6	mA
Idle—LTE eDRX	Period = 40 sec	1.3	1.8	4	mA
Airplane mode	<ul style="list-style-type: none"> ▪ Radio off ▪ USB-SS 	1.3	1.3	4	mA
Power state—ULPS					
Ultra Low Power Mode (ULPM)	See Table 3-17 on page 52 for details.				
Power Saving Mode (PSM)	Non-active	6	8	32	μA

Table 3-13: WP7607 and WP7609 Current Consumption Values (Continued)

Mode	Parameter	Min	Typ ^a	Max ^b	Units
GNSS ^j					
GNSS	Acquisition (Airplane mode, cold start)	23	25	35	mA
	Tracking (Registered)	23	25	35	mA

- a. Typical, measured at nominal temperature, nominal voltage.
- b. Worst case, measured at 85° C, on supported DC range.
- c. At GSM conducted 4 slot max Tx output power, measured at peak current on supported DC range.
- d. At GSM conducted 4 slot max TX output power, measured at average current on supported DC range.
- e. At WCDMA conducted max Tx output power (see [Table 3-24](#) on page 55)
- f. Only applicable to the WP7609.
- g. At LTE conducted max Tx output power (see [Table 3-39](#) on page 59)
- h. Only applicable to the WP7607.
- j. GNSS current consumption values are for the GNSS radio only. For total consumption, add the GNSS value to the consumption for the mode being used.

Table 3-14: WP7608 Current Consumption Values

Mode	Parameter	Min	Typ ^a	Max ^b	Units
Power state — Active					
GSM/GPRS/EDGE data transfer	E-GSM 900	160	650	2291 ^c 826 ^d	mA
	DCS 1800	590	590	970 ^c 512 ^d	mA
HSDPA data transfer ^e	B1	160	710	980	mA
	B8	140	650	880	mA
LTE Data transfer ^f	B1	230	750	950	mA
	B3	220	780	880	mA
	B5	200	650	770	mA
	B8	200	680	850	mA
	B40	140	440	590	mA
	B41	140	430	620	mA
Idle — GSM/GPRS/EDGE	<ul style="list-style-type: none"> ▪ Registered ▪ MFRM=9 ▪ USB active 	25	25	36	mA
Idle — WCDMA	<ul style="list-style-type: none"> ▪ Registered ▪ DRX=8 ▪ USB active 	25	25	36	mA
Idle — LTE	<ul style="list-style-type: none"> ▪ Registered ▪ Paging cycle=256 ▪ USB active 	25	26	39	mA

Table 3-14: WP7608 Current Consumption Values (Continued)

Mode	Parameter	Min	Typ ^a	Max ^b	Units
Airplane mode	<ul style="list-style-type: none"> ▪ Radio off ▪ USB active 	25	25	36	mA
Power state — Sleep					
Idle — GSM/GPRS/EDGE	<ul style="list-style-type: none"> ▪ Registered ▪ MFRM=9 ▪ USB-SS 	1.8	2.0	3.6	mA
Idle — WCDMA	<ul style="list-style-type: none"> ▪ Registered ▪ DRX=8 ▪ USB-SS 	1.6	1.7	3.2	mA
Idle — LTE	<ul style="list-style-type: none"> ▪ Registered ▪ Paging cycle=256 ▪ USB-SS 	1.7	1.9	6	mA
Idle — LTE eDRX	Period = 40 sec	1.5	1.7	4	mA
Airplane mode	<ul style="list-style-type: none"> ▪ Radio off ▪ USB-SS 	1.3	1.3	4	mA
Power state — Ultra Low Power Mode (ULPM)					
Ultra Low Power Mode (ULPM)	See Table 3-17 on page 52 for details.				
Power Saving Mode (PSM)	Non-active	11	15	32	µA
GNSS ^g					
GNSS	Acquisition (Airplane mode, cold start)	23	25	35	mA
	Tracking (Registered)	23	25	35	mA

- a. Typical, measured at nominal temperature, nominal voltage.
- b. Worst case, measured at 70 °C, 3.4V.
- c. Measured at peak current on supported DC range.
- d. At GSM conducted 4 slot max TX output power, measured at average current on supported DC range.
- e. At WCDMA conducted max Tx output power (see [Table 3-25](#) on page 55)
- f. At LTE conducted max Tx output power (see [Table 3-40](#) on page 59)
- g. GNSS current consumption values are for the GNSS radio only. For total consumption, add the GNSS value to the consumption for the mode being used.

Table 3-15: WP7610 Current Consumption Values

Mode	Parameter	Min	Typ ^a	Max ^b	Units
Power state — Active					
HSDPA data transfer ^c	B2	120	790	800	mA
	B4	130	670	950	mA
	B5	120	480	730	mA

Table 3-15: WP7610 Current Consumption Values (Continued)

Mode	Parameter	Min	Typ ^a	Max ^b	Units
LTE Data transfer ^d	B2	210	770	980	mA
	B4	210	710	1000	mA
	B5	190	530	700	mA
	B12	190	570	700	mA
	B13	190	620	800	mA
	B14	190	640	700	mA
	B17	190	580	700	mA
	B66	210	720	1000	mA
Idle — WCDMA	<ul style="list-style-type: none"> ▪ Registered ▪ DRX=8 ▪ USB active 	25	25	36	mA
Idle — LTE	<ul style="list-style-type: none"> ▪ Registered ▪ Paging cycle=256 ▪ USB active 	25	26	39	mA
Airplane mode	<ul style="list-style-type: none"> ▪ Radio off ▪ USB active 	25	25	36	mA
Power state — Sleep					
Idle — WCDMA	<ul style="list-style-type: none"> ▪ Registered ▪ DRX=8 ▪ USB-SS 	1.2	1.6	4	mA
Idle — LTE	<ul style="list-style-type: none"> ▪ Registered ▪ Paging cycle=256 ▪ USB-SS 	1.7	1.8	6	mA
Idle — LTE eDRX	Period = 40 sec	1	1.3	3.7	mA
Airplane mode	<ul style="list-style-type: none"> ▪ Radio off ▪ USB-SS 	1	1.3	4	mA
Power state — ULPS					
Ultra Low Power Mode (ULPM)	Not supported				
Power Saving Mode (PSM)	Non-active	7	8	21	μA
GNSS ^e					
GNSS	Acquisition (Airplane mode, cold start)	23	25	35	mA
	Tracking (Registered)	23	25	35	mA

a. Typical, measured at nominal temperature, nominal voltage.
 b. Worst case, measured at 70 °C, 3.4V.
 c. At WCDMA conducted max Tx output power (see [Table 3-28](#) on page 55)

- d. At LTE conducted max Tx output power (see [Table 3-43](#) on page 60)
- e. GNSS current consumption values are for the GNSS radio only. For total consumption, add the GNSS value to the consumption for the mode being used.

Table 3-16: WP7611, WP7611D Current Consumption Values

Mode	Parameter	Min	Typ ^a	Max ^b	Units
Power state — Active					
HSDPA data transfer ^c	B2	120	790	800	mA
	B4	120	600	950	mA
	B5	120	480	730	mA
LTE Data transfer ^d	B2	210	770	980	mA
	B4	210	710	1000	mA
	B5	190	530	700	mA
	B12	190	570	700	mA
	B13	190	570	800	mA
	B14	190	580	700	mA
	B25	210	770	980	mA
	B26	190	530	700	mA
	B66	220	640	1000	mA
B71	190	570	700	mA	
Idle — WCDMA	<ul style="list-style-type: none"> ▪ Registered ▪ DRX=8 ▪ USB active 	25	25	36	mA
Idle — LTE	<ul style="list-style-type: none"> ▪ Registered ▪ Paging cycle=256 ▪ USB active 	25	26	39	mA
Airplane mode	<ul style="list-style-type: none"> ▪ Radio off ▪ USB active 	25	25	36	mA
Power state — Sleep					
Idle — WCDMA	<ul style="list-style-type: none"> ▪ Registered ▪ DRX=8 ▪ USB-SS 	1.2	1.6	4	mA
Idle — LTE	<ul style="list-style-type: none"> ▪ Registered ▪ Paging cycle=256 ▪ USB-SS 	1.7	1.8	6	mA
Idle — LTE eDRX	Period = 40 sec	1	1.3	3.7	mA
Airplane mode	<ul style="list-style-type: none"> ▪ Radio off ▪ USB-SS 	1	1.3	4	mA

Table 3-16: WP7611, WP7611D Current Consumption Values (Continued)

Mode	Parameter	Min	Typ ^a	Max ^b	Units
Power state — ULPS					
Ultra Low Power Mode (ULPM)	Not supported				
Power Saving Mode (PSM)	Non-active	7	8	21	μA
GNSS ^e					
GNSS	Acquisition (Airplane mode, cold start)	15	25	35	mA
	Tracking (Registered)	15	25	35	mA

- a. Typical, measured at nominal temperature, nominal voltage.
- b. Worst case, measured at 70°C, 3.4V.
- c. At WCDMA conducted max Tx output power (see Table 3-22 on page 54)
- d. At LTE conducted max Tx output power (see Table 3-37 on page 58)
- e. GNSS current consumption values are for the GNSS radio only. For total consumption, add the GNSS value to the consumption for the mode being used.

Table 3-17 describes parameters that contribute to total current consumption while the module is in ULPM.

Table 3-17: ULPM Current Consumption^a

POWER_ON_N State	ULPM Wake Up Source	Hardware Pin State	Value for WP7601, WP7603, WP7607 and WP7609 ^b	Value for WP7608 ^b
Off	Wakeup timer	-	8 ?A	158 ?A
	GPIO36 GPIO38 ADC2 ^c ADC3 ^c	Configured as open (default)	8 ?A	15 ?A
		Other (Configured as closed and/or dependent on external circuitry design.)	≤ 58 ?A	≤ 65 ?A
On	Wakeup timer	-	908 ?A	915 ?A
	GPIO36 GPIO38 ADC2 ^c ADC3 ^c	Configured as open (default)	908 ?A	915 ?A
		Other (Configured as closed and/or dependent on external circuitry design.)	≤ 958 ?A	≤ 965 ?A

- a. Available for Group A variants only.
- b. Typical values.
- c. Current consumption is affected by the interval between successive ADC measurements — longer intervals result in significantly lower current consumption.

3.3 RF

This section presents the module’s WWAN RF interface, and defines the specifications for the LTE, HSPA, WCDMA, and GSM interfaces for supporting modules.

Note: RF sensitivity values presented in this section are for soldered-down modules. Sensitivity values decrease for modules installed in snap-in sockets, which might prevent the module from meeting 3GPP minimum specifications.

AirPrime WP76XX embedded modules are designed to be compliant with the standards in [Table 3-18](#).

Table 3-18: Standards Compliance

Technology/Standards	Modules
LTE: 3GPP Release 10	WP7601, WP7603, WP7605, WP7607, WP7608, WP7609, WP7610, WP7611, WP7611D
UMTS (WCDMA): 3GPP Release 8	WP7603, WP7605, WP7607, WP7608, WP7609, WP7610, WP7611, WP7611D
GSM: <ul style="list-style-type: none"> ▪ ETSI GSM 05.05 ▪ 3GPP TS 45.005/Antecedent TS 05.05 	WP7607, WP7608, WP7609

3.3.1 GSM/GPRS/EDGE RF Interface

This section presents the GSM/GPRS/EDGE RF specification for AirPrime WP7607, WP7608, and WP7609 modules.

3.3.1.1 GSM/GPRS/EDGE Tx Output Power

The module’s GSM/GPRS/EDGE maximum transmitter output power is specified in [Table 3-22](#).

Table 3-19: WP7607 / WP7608 / WP7609 Conducted Tx Max Output Power Tolerances — GSM / GPRS / EDGE^a

RF band	Min	Typ	Max	Units	Notes
E-GSM 900	31	33	34	dBm	GMSK mode (Class 4; 2 W, 33 dBm)
	24.5	27	29.5	dBm	8PSK mode (Class E2; 0.5 W, 27 dBm)
DCS 1800	28	30	31	dBm	GMSK mode (Class 1; 1 W, 30 dBm)
	23.5	26	28.5	dBm	8PSK mode (Class E2; 0.4 W, 26 dBm)

a. Stated power tolerances satisfy 3GPP TS 51.010-1 requirements for normal (25°C) conditions.

3.3.1.2 GSM/GPRS/EDGE Rx Sensitivity

The module’s GSM/GPRS/EDGE receiver sensitivity is specified in [Table 3-29](#).

Table 3-20: WP7607 / WP7609 Conducted Rx Sensitivity — GSM / GPRS / EDGE Bands^a

	@ +25 °C (dBm) ^b	@ Class A (dBm) ^c
E-GSM 900	-109	-108
DCS 1800	-109	-108

- a. Stated sensitivity values satisfy 3GPP TS 51.010-1 requirements for normal (25 °C) and Class A (extreme) conditions.
- b. Typical value
- c. Typical value, tested at Class A extreme condition

Table 3-21: WP7608 Conducted Rx Sensitivity — GSM / GPRS / EDGE Bands^a

	@ +25 °C (dBm) ^b	@ Class A (dBm) ^c
E-GSM 900	-110	-109
DCS 1800	-109	-108

- a. Stated sensitivity values satisfy 3GPP TS 51.010-1 requirements for normal (25 °C) and Class A (extreme) conditions.
- b. Typical value
- c. Typical value, tested at Class A extreme condition

3.3.2 WCDMA RF Interface

This section presents the WCDMA RF specification for AirPrime WP7603, WP7605, WP7607, WP7608, WP7609, WP7610, WP7611, WP7611D modules.

3.3.2.1 WCDMA Tx Output Power

The module’s WCDMA maximum transmitter output power is specified in the following tables.

Table 3-22: WP7603 Conducted Tx Max Output Power Tolerances — WCDMA^a

RF Band	Min	Typ	Max	Units	Notes
B2	22	23	24	dBm	Power class 3
B4	22	23	24	dBm	Power class 3
B5	22	23	24	dBm	Power class 3

- a. Stated power tolerances satisfy 3GPP TS 34.121-1 requirements for normal (25 °C) conditions.

Table 3-23: WP7605 Conducted Tx Max Output Power Tolerances — WCDMA^a

RF Band	Min	Typ	Max	Units	Notes
B1	22	23	24	dBm	Power class 3 bis
B6	22	23	24	dBm	Power class 3 bis
B19	22	23	24	dBm	Power class 3 bis

- a. Stated power tolerances satisfy 3GPP TS 34.121-1 requirements for normal (25°C) conditions.

Table 3-24: WP7607 Conducted Tx Max Output Power Tolerances — WCDMA

RF Band	Min	Typ ^a	Max	Units	Notes
B1	21.5	23	24	dBm	Power class 3 bis
B8	21.5	23	24	dBm	Power class 3 bis

- a. Stated typical power tolerance satisfies 3GPP TS 34.121-1 requirements for normal (25°C) conditions.

Table 3-25: WP7608 Conducted Tx Max Output Power Tolerances — WCDMA

RF band	Min	Typ ^a	Max	Units	Notes
B1	23	24	25	dBm	Power class 3
B8	23	24	25	dBm	Power class 3

- a. Stated typical power tolerance satisfies 3GPP TS 34.121-1 requirements for normal (25°C) conditions.

Table 3-26: WP7609 Conducted Tx Max Output Power Tolerances — WCDMA

RF band	Min	Typ ^a	Max	Units	Notes
B1	21.5	23	24	dBm	Power class 3 bis
B5	21.5	23	24	dBm	Power class 3 bis
B8	21.5	23	24	dBm	Power class 3 bis

- a. Stated typical power tolerance satisfies 3GPP TS 34.121-1 requirements for normal (25°C) conditions.

Table 3-27: WP7610 Conducted Tx Max Output Power Tolerances — WCDMA

RF band	Min	Typ ^a	Max	Units	Notes
B2	21.5	23	24	dBm	Power class 3
B4	21.5	23	24	dBm	Power class 3
B5	21.5	23	24	dBm	Power class 3

- a. Stated typical power tolerance satisfies 3GPP TS 34.121-1 requirements for normal (25°C) conditions.

Table 3-28: WP7611, WP7611D Conducted Tx Max Output Power Tolerances — WCDMA

RF band	Min	Typ ^a	Max	Units	Notes
B2	21.5	23	24	dBm	Power class 3 bis
B4	21.5	23	24	dBm	Power class 3 bis
B5	21.5	23	24	dBm	Power class 3 bis

- a. Stated typical power tolerance satisfies 3GPP TS 34.121-1 requirements for normal (25°C) conditions.

3.3.2.2 WCDMA Rx Sensitivity

The module’s WCDMA receiver sensitivity is specified in the following tables.

Table 3-29: WP7603 Conducted Rx Sensitivity — WCDMA Bands^{a,b}

Band	+25 °C		Class A		Standard Limit (dBm)	Notes
	Primary (dBm) ^c	Secondary (dBm) ^c	Primary (dBm) ^d	Secondary (dBm) ^d		
B2	-112	-113	-111	-112	-104	CS 0.1% BER 12.2 kbps Reference Measurement Channel
B4	-111	-112	-109	-111	-106	
B5	-113	-113	-111	-108	-104	

- a. Stated sensitivity values satisfy 3GPP TS 34.121-1 V8.10.0 requirements for normal (25 °C) and Class A (extreme) conditions.
- b. RF sensitivity values are for soldered-down modules.
- c. Typical value.
- d. Typical value, tested at Class A extreme condition.

Table 3-30: WP7605 Conducted Rx Sensitivity — WCDMA Bands^{a,b}

Band	+25 °C		Class A		Standard Limit (dBm)	Notes
	Primary (dBm) ^c	Secondary (dBm) ^c	Primary (dBm) ^d	Secondary (dBm) ^d		
B1	-112	-112	-110	-111	-106.7	CS 0.1% BER 12.1 kbps Reference Measurement Channel
B6	-112	-111	-110	-111	-106.7	
B19	-112	-111	-111	-111	-106.7	

- a. Stated sensitivity values satisfy 3GPP TS 34.121-1 V8.10.0 requirements for normal (25 °C) and Class A (extreme) conditions.
- b. RF sensitivity values are for soldered-down modules.
- c. Typical value.
- d. Typical value, tested at Class A extreme temperature.

Table 3-31: WP7607 Conducted Rx Sensitivity — WCDMA Bands^{a,b}

Band	+25 °C		Class A		Standard Limit (dBm)	Notes
	Primary (dBm) ^c	Secondary (dBm) ^c	Primary (dBm) ^d	Secondary (dBm) ^d		
B1	-108	-108	-107	-107	-106	CS 0.1% BER 12.2 kbps Reference Measurement Channel
B8	-109	-109	-109	-109	-103	

- a. Stated sensitivity values satisfy 3GPP TS 34.121-1 V8.10.0 requirements for normal (25 °C) and Class A (extreme) conditions.
- b. RF sensitivity values are for soldered-down modules.
- c. Typical value.
- d. Typical value, tested at Class A extreme temperature.

Table 3-32: WP7608 Conducted Rx Sensitivity — WCDMA Bands^{a,b}

Band	+25 °C		Class A		Standard Limit (dBm)	Notes
	Primary (dBm) ^c	Secondary (dBm) ^c	Primary (dBm) ^d	Secondary (dBm) ^d		
B1	-109	-109	-107	-109	-106	CS 0.1% BER 12.2 k bps Reference Measurement Channel
B8	-110	-110	-108	-109	-103	

- a. Stated sensitivity values satisfy 3GPP TS 34.121-1 V8.10.0 requirements for normal (25 °C) and Class A (extreme) conditions.
- b. RF sensitivity values are for soldered-down modules.
- c. Typical value.
- d. Typical value, tested at Class A extreme temperature.

Table 3-33: WP7609 Conducted Rx Sensitivity — WCDMA Bands^{a,b}

Band	+25 °C		Class A		Standard Limit (dBm)	Notes
	Primary (dBm) ^c	Secondary (dBm) ^c	Primary (dBm) ^d	Secondary (dBm) ^d		
B1	-108	-108	-107	-107	-106	CS 0.1% BER 12.2 k bps Reference Measurement Channel
B5	-109	-108	-108	-106	-104	
B8	-109	-109	-109	-109	-103	

- a. Stated sensitivity values satisfy 3GPP TS 34.121-1 V8.10.0 requirements for normal (25 °C) and Class A (extreme) conditions.
- b. RF sensitivity values are for soldered-down modules.
- c. Typical value.
- d. Typical value, tested at Class A extreme temperature.

Table 3-34: WP7610 Conducted Rx Sensitivity — WCDMA Bands^a

Band	+25 °C		Class A		Standard Limit (dBm)	Notes
	Primary (dBm) ^b	Secondary (dBm) ^c	Primary (dBm) ^c	Secondary (dBm) ^d		
B2	-109	-110.5	-107.5	-109.5	-104	CS 0.1% BER 12.2 k bps Reference Measurement Channel
B4	-110	-110.5	-109	-109.5	-106	
B5	-111	-111	-109.5	-110	-104	

- a. Stated sensitivity values satisfy 3GPP TS 34.121-1 V8.10.0 requirements for normal (25 °C) and Class A (extreme) conditions.
- b. Typical value.
- c. Typical value, tested at Class A extreme condition.

Table 3-35: WP7611, WP7611D Conducted Rx Sensitivity — WCDMA Bands^a

Band	+25 °C		Class A		Standard Limit (dBm)	Notes
	Primary (dBm) ^b	Secondary (dBm) ^c	Primary (dBm) ^c	Secondary (dBm) ^d		
B2	-110.5	-110.5	-109.5	-109.5	-104	CS 0.1% BER 12.2 kbps Reference Measurement Channel
B4	-110	-110	-109	-109	-106	
B5	-111.5	-110	-110.5	-109	-104	

- a. Stated sensitivity values satisfy 3GPP TS 34.121-1 V8.10.0 requirements for normal (25 °C) and Class A (extreme) conditions.
- b. Typical value.
- c. Typical value, tested at Class A extreme condition.

3.3.3 LTE RF Interface

This section presents the LTE RF specification for AirPrime WP76XX modules.

3.3.3.1 LTE Tx Output Power

The module’s LTE maximum transmitter output power is specified in the following tables.

Table 3-36: WP7601 Conducted Tx Max Output Power Tolerances — LTE^a

RF Band	Operating Condition	Min	Typ	Max	Units	Notes
B4	Normal (25 °C)	22	23	24	dBm	Power class 3
B13	Normal (25 °C)	22	23	24	dBm	Power class 3

- a. Stated power tolerances satisfy 3GPP TS 36.521-1 requirements for normal (25 °C) and Class A (extreme) conditions.

Table 3-37: WP7603 Conducted Tx Max Output Power Tolerances — LTE^a

RF Band	Operating Condition	Min	Typ	Max	Units	Notes
B2	Normal (25 °C)	22	23	24	dBm	Power class 3
B4	Normal (25 °C)	22	23	24	dBm	Power class 3
B5	Normal (25 °C)	22	23	24	dBm	Power class 3
B12	Normal (25 °C)	22	23	24	dBm	Power class 3

- a. Stated power tolerances satisfy 3GPP TS 36.521-1 requirements for normal (25 °C) and Class A (extreme) conditions.

Table 3-38: WP7605 Conducted Tx Max Output Power Tolerances — LTE^a

RF Band	Operating Condition	Min	Typ	Max	Units	Notes
B1	Normal (25 °C)	22	23	24	dBm	Power class 3
B3	Normal (25 °C)	22	23	24	dBm	Power class 3
B8	Normal (25 °C)	22	23	24	dBm	Power class 3
B11	Normal (25 °C)	22	23	24	dBm	Power class 3

Table 3-38: WP7605 Conducted Tx Max Output Power Tolerances — LTE^a (Continued)

RF Band	Operating Condition	Min	Typ	Max	Units	Notes
B18	Normal (25°C)	22	23	24	dBm	Power class 3
B19	Normal (25°C)	22	23	24	dBm	Power class 3
B21	Normal (25°C)	22	23	24	dBm	Power class 3

a. Stated power tolerances satisfy 3GPP TS 36.521-1 requirements for normal (25°C) and Class A (extreme) conditions.

Table 3-39: WP7607 Conducted Tx Max Output Power Tolerances — LTE^a

RF Band	Operating Condition	Min	Typ	Max	Units	Notes
B1	Normal (25°C)	21	23	24	dBm	Power class 3
B3	Normal (25°C)	21	23	24	dBm	Power class 3
B7	Normal (25°C)	21	23	24	dBm	Power class 3
B8	Normal (25°C)	21	23	24	dBm	Power class 3
B20	Normal (25°C)	21	23	24	dBm	Power class 3
B28	Normal (25°C)	21	23	24	dBm	Power class 3

a. Stated typical power tolerance satisfies 3GPP TS 36.521-1 requirements for normal (25°C) and Class A (extreme) conditions.

Table 3-40: WP7608 Conducted Tx Max Output Power Tolerances — LTE^a

RF Band	Operating Condition	Min	Typ	Max	Units	Notes
B1	Normal (25°C)	21	23	24	dBm	Power class 3
B3	Normal (25°C)	21	23	24	dBm	Power class 3
B5	Normal (25°C)	21	23	24	dBm	Power class 3
B8	Normal (25°C)	21	23	24	dBm	Power class 3
B40	Normal (25°C)	21	23	24	dBm	Power class 3
B41	Normal (25°C)	21	23	24	dBm	Power class 3

a. Stated typical power tolerance satisfies 3GPP TS 36.521-1 requirements for normal (25°C) and Class A (extreme) conditions.

Table 3-41: WP7609 Conducted Tx Max Output Power Tolerances — LTE^a

RF Band	Operating Condition	Min	Typ	Max	Units	Notes
B1	Normal (25°C)	21	23	24	dBm	Power class 3
B3	Normal (25°C)	21	23	24	dBm	Power class 3
B5	Normal (25°C)	21	23	24	dBm	Power class 3
B7	Normal (25°C)	21	23	24	dBm	Power class 3
B8	Normal (25°C)	21	23	24	dBm	Power class 3
B28	Normal (25°C)	21	23	24	dBm	Power class 3

a. Stated typical power tolerance satisfies 3GPP TS 36.521-1 requirements for normal (25°C) and Class A (extreme) conditions.

Table 3-42: WP7610 Conducted Tx Max Output Power Tolerances — LTE^a

RF Band	Operating Condition	Min	Typ	Max	Units	Notes
B2	Normal (25°C)	21	23	24	dBm	Power class 3
B4	Normal (25°C)	21	23	24	dBm	Power class 3
B5	Normal (25°C)	21	23	24	dBm	Power class 3
B12	Normal (25°C)	21	23	24	dBm	Power class 3
B13	Normal (25°C)	21	23	24	dBm	Power class 3
B14	Normal (25°C)	21	23	24	dBm	Power class 3
B17	Normal (25°C)	21	23	24	dBm	Power class 3
B66	Normal (25°C)	21	23	24	dBm	Power class 3

a. Stated typical power tolerance satisfies 3GPP TS 36.521-1 requirements for normal (25°C) and Class A (extreme) conditions.

Table 3-43: WP7611, WP7611D Conducted Tx Max Output Power Tolerances — LTE^a

RF Band	Operating Condition	Min	Typ	Max	Units	Notes
B2	Normal (25°C)	21	23	24	dBm	Power class 3
B4	Normal (25°C)	21	23	24	dBm	Power class 3
B5	Normal (25°C)	21	23	24	dBm	Power class 3
B12	Normal (25°C)	21	23	24	dBm	Power class 3
B13	Normal (25°C)	21	23	24	dBm	Power class 3
B14	Normal (25°C)	21	23	24	dBm	Power class 3
B25	Normal (25°C)	21	23	24	dBm	Power class 3
B26	Normal (25°C)	21	23	24	dBm	Power class 3
B66	Normal (25°C)	21	23	24	dBm	Power class 3
B71	Normal (25°C)	21	23	24	dBm	Power class 3

a. Stated typical power tolerance satisfies 3GPP TS 36.521-1 requirements for normal (25°C) and Class A (extreme) conditions.

3.3.3.2 LTE Rx Sensitivity

The module's LTE receiver sensitivity is specified in the following tables.

Table 3-44: WP7601 Conducted Rx Sensitivity — LTE Bands^a

LTE Bands		+25°C (dBm)			Class A (dBm)			SIMO (Worst case) ^b
		Primary (Typical)	Secondary (Typical)	SIMO (Typical)	Primary (Typical)	Secondary (Typical)	SIMO (Typical)	
B4	Full RB BW: 10 MHz ^c	-98	-100	-102	-97	-99	-100	-96.3
B13		-99	-98	-101	-98	-98	-99	-93.3

- a. RF sensitivity values are for soldered-down modules.
- b. Per 3GPP specification.
- c. Sensitivity values scale with bandwidth: $x_MHz_Sensitivity = 10_MHz_Sensitivity - 10 \times \log(10\text{ MHz}/x_MHz)$
Note: Bandwidth support is dependent on firmware version.

Table 3-45: WP7603 Conducted Rx Sensitivity — LTE Bands^a

LTE Bands		+25°C (dBm)			Class A (dBm)			SIMO (Worst case) ^b
		Primary (Typical)	Secondary (Typical)	SIMO (Typical)	Primary (Typical)	Secondary (Typical)	SIMO (Typical)	
B2	Full RB BW: 10 MHz ^c	-99	-99	-102	-98	-99	-101	-94.3
B4		-98	-100	-102	-97	-99	-100	-96.3
B5		-100	-100	-103	-99	-99	-100	-94.3
B12		-99	-99	-101	-98	-98	-100	-93.3

- a. RF sensitivity values are for soldered-down modules.
- b. Per 3GPP specification.
- c. Sensitivity values scale with bandwidth: $x_MHz_Sensitivity = 10_MHz_Sensitivity - 10 \times \log(10\text{ MHz}/x_MHz)$
Note: Bandwidth support is dependent on firmware version.

Table 3-46: WP7605 Conducted Rx Sensitivity — LTE Bands

LTE Bands		+25°C (dBm)			Class A (dBm)			SIMO (Worst case) ^a
		Primary (Typical)	Secondary (Typical)	SIMO (Typical)	Primary (Typical)	Secondary (Typical)	SIMO (Typical)	
B1	Full RB BW: 10 MHz	-98	-100	-101	-97	-99	-101	-96.3
B3		-98	-100	-101	-97	-99	-100	-93.3
B8		-100	-100	-102	-99	-99	-101	-93.3
B11		-97	-100	-100	-97	-99	-100	-96.3
B18		-100	-99	-102	-99	-98	-101	-96.3
B19		-100	-99	-102	-99	-98	-101	-96.3
B21		-99	-100	-102	-98	-99	-101	-96.3

- a. Per 3GPP specification.

Table 3-47: WP7607 and WP7609 Conducted Rx Sensitivity — LTE Bands^a

LTE Bands		+25 °C (dBm)			Class A (dBm)			SIMO (Worst case) ^b
		Primary (Typical)	Secondary (Typical)	SIMO (Typical)	Primary (Typical)	Secondary (Typical)	SIMO (Typical)	
B1	Full RB BW: 10 MHz ^c	-97.5	-96.5	-100	-96.5	-96	-99	-96.3
B3		-97	-97	-100	-96.5	-97	-99	-93.3
B5 ^d		-97.5	-96.5	-99.5	-96	-95	-98	-94.3
B7		-95	-96.5	-99	-94.5	-96	-98	-94.3
B8		-98	-97	-100	-97.5	-96	-99	-93.3
B20 ^e		-97	-96	-99	-97	-95	-99	-93.3
B28		-96	-93	-98.5	-95.5	-92	-98	-94.8

- a. RF sensitivity values are for soldered-down modules.
- b. Per 3GPP specification.
- c. Sensitivity values scale with bandwidth: $x_MHz_Sensitivity = 10_MHz_Sensitivity - 10 \times \log(10\text{ MHz}/x_MHz)$
Note: Bandwidth support is dependent on firmware version.
- d. Only applicable to the WP7609.
- e. Only applicable to the WP7607.

Table 3-48: WP7608 Conducted Rx Sensitivity — LTE Bands^a

LTE Bands		+25 °C (dBm)			Class A (dBm)			SIMO (Worst case) ^b
		Primary (Typical)	Secondary (Typical)	SIMO (Typical)	Primary (Typical)	Secondary (Typical)	SIMO (Typical)	
B1	Full RB BW: 10 MHz ^c	-97.5	-98.5	-101	-96	-97	-99	-96.3
B3		-98	-98	-101	-97	-96.5	-99	-93.3
B5		-98.5	-96	-100.5	-97.5	-93	-98	-94.3
B8		-98.5	-99	-102	-98	-97.5	-100	-93.3
B40		-98	-98	-101	-97	-96.5	-99	-93.3
B41		-97.5	-97.5	-100.5	-96	-95.5	-98	-94.8

- a. RF sensitivity values are for soldered-down modules.
- b. Per 3GPP specification.
- c. Sensitivity values scale with bandwidth: $x_MHz_Sensitivity = 10_MHz_Sensitivity - 10 \times \log(10\text{ MHz}/x_MHz)$
Note: Bandwidth support is dependent on firmware version.

Table 3-49: WP7610 Conducted Rx Sensitivity — LTE Bands

LTE bands		+25 °C (dBm)			Class A (dBm)			SIMO (Worst case) ^a
		Primary (Typical)	Secondary (Typical)	SIMO (Typical)	Primary (Typical)	Secondary (Typical)	SIMO (Typical)	
B2	Full RB BW: 10 MHz	-96.5	-97	-100	-95.5	-96	-99	-94.3
B4	Full RB BW: 10 MHz	-97.5	-97.5	-100	-96.5	-96.5	-99	-96.3

Table 3-49: WP7610 Conducted Rx Sensitivity — LTE Bands (Continued)

LTE bands		+25°C (dBm)			Class A (dBm)			SIMO (Worst case) ^a
		Primary (Typical)	Secondary (Typical)	SIMO (Typical)	Primary (Typical)	Secondary (Typical)	SIMO (Typical)	
B5	25 RB BW: 10 MHz	-98.5	-98	-101.5	-97	-97	-100.5	-94.3
B12	20 RB BW: 10 MHz	-96.5	-93.5	-98.5	-94.5	-93	-97	-93.3
B13	20 RB BW: 10 MHz	-99	-94	-100	-98	-92	-99	-93.3
B14	15 RB BW: 10 MHz	-96.5	-95	-99	-95	-94	-97.5	-93.3
B17	20 RB BW: 10 MHz	-96	-93.5	-98	-94.5	-93	-96.5	-93.3
B66	Full RB BW: 10 MHz	-97.5	-97.5	-100	-96.5	-96.5	-99	-95.8

a. Per 3GPP specification.

Table 3-50: WP7611, WP7611D Conducted Rx Sensitivity — LTE Bands

LTE bands		+25°C (dBm)			Class A (dBm)			SIMO (Worst case) ^a
		Primary (Typical)	Secondary (Typical)	SIMO (Typical)	Primary (Typical)	Secondary (Typical)	SIMO (Typical)	
B2	Full RB BW: 10 MHz	-98	-98	-100	-97	-97.5	-99.5	-94.3
B4	Full RB BW: 10 MHz	-98	-97.5	-99.5	-97	-96.5	-98.5	-96.3
B5	25 RB BW: 10 MHz	-99	-98	-100.5	-98	-97	-99.5	-94.3
B12	20 RB BW: 10 MHz	-97.5	-96	-99	-96	-95.5	-98	-93.3
B13	20 RB BW: 10 MHz	-97.5	-95	-99	-96.5	-94	-98	-93.3
B14	15 RB BW: 10 MHz	-97.5	-97	-99.5	-96.5	-96	-98.5	-93.3
B25	Full RB BW: 10 MHz	-98	-98	-100	-97	-97.5	-99.5	-92.8
B26	25 RB BW: 10 MHz	-99	-98	-100.5	-98	-97	-99.5	-93.8
B66	Full RB BW: 10 MHz	-98	-98	-100	-97	-97	-99	-95.8
B71	25 RB BW: 10 MHz	-98	-98	-100	-96.5	-97	-99	-93.5

a. Per 3GPP specification.

3.3.4 WWAN Antenna Interface

The following table defines the WWAN antenna interfaces of the AirPrime WP76XX modules.

Table 3-51: WP76XX WWAN Antenna Interface Pins

Pin #	Signal name	Direction	Function
30	GND		Diversity Antenna Ground
31	RF_DIV	Input	Diversity Antenna Interface
32	GND		Diversity Antenna Ground
48	GND		Primary Antenna Ground
49	RF_MAIN	Input/Output	Primary Antenna Interface
50	GND		Primary Antenna Ground
111	GND		Diversity Antenna Ground
113	GND		Diversity Antenna Ground
136	GND		Primary Antenna Ground
139	GND		Primary Antenna Ground

3.3.4.1 WWAN Antenna Recommendations

Table 3-52 defines the key characteristics to consider for antenna selection.

Table 3-52: Antenna Recommendations^a

Parameter		Recommendations	Comments
Antenna system		External multi-band antenna system	Dual WWAN antennas for diversity (Antenna 1 / Antenna 2) ^b
Operating bands	WP7601	746–787 MHz	Operating bands depend on the module's supported bands / modes.
		1710–1755 MHz	
		2110–2155 MHz	
	WP7603	699–894 MHz	
	WP7610	1710–2200 MHz	
WP7611	2110–2155 MHz		
WP7611D			

Table 3-52: Antenna Recommendations^a (Continued)

Parameter		Recommendations	Comments
Operating bands	WP7608 WP7611 WP7611D	824–894 MHz	Operating bands depend on the module’s supported bands/modes.
		880–960 MHz	
		1710–1880 MHz	
		1920–2170 MHz	
		2300–2400 MHz	
	WP7605 WP7607 WP7609 WP7611 WP7611D	2535–2655 MHz	
		703–960 MHz	
		1427.9–1510.9 MHz	
		1710–1980 MHz	
		2110–2170 MHz	
		2500–2690 MHz	
VSWR		< 2.5:1 (worst case)	<ul style="list-style-type: none"> On all bands including band edges Applies to both antennas
Total radiated efficiency		> 50% on all bands	<ul style="list-style-type: none"> Measured at the RF connector. Applies to both antennas. Includes mismatch losses, losses in the matching circuit, and antenna losses, excluding cable loss. Semtech recommends using antenna efficiency as the primary parameter for evaluating the antenna system. Peak gain is not a good indication of antenna performance when integrated with a host device (the antenna does not provide omnidirectional gain patterns). Peak gain can be affected by antenna size, location, design type, etc. — the antenna gain pattern remains fixed unless one or more of these parameters change.
Radiation patterns		Nominally omnidirectional radiation pattern in azimuth plane.	
Envelope correlation coefficient between Antenna 1 and Antenna 2		<ul style="list-style-type: none"> < 0.5 on Rx bands below 960 MHz < 0.2 on Rx bands above 1.4 GHz 	
Mean Effective Gain (MEG)		≥ -3 dBi	
Mean Effective Gain Imbalance — Antenna 1 and Antenna 2 (MEG1 / MEG2)		< 6 dB for diversity operation	
Maximum antenna gain		Must not exceed antenna gains due to RF exposure and ERP/EIRP limits, as listed in the module’s FCC grant.	

Table 3-52: Antenna Recommendations^a (Continued)

Parameter	Recommendations	Comments
Isolation between Antenna 1 and Antenna 2 (S21)	> 10 dB	<ul style="list-style-type: none"> ▪ If antennas can be moved, test all positions for both antennas. ▪ Unless otherwise specified, this isolation requirement must be maintained for optimum operation. ▪ Make sure all other wireless devices (Bluetooth or WLAN antennas, etc.) are turned OFF to avoid interference.
Maximum voltage applied to antenna	6.3 VDC	
Power handling	> 1 W on all bands	<ul style="list-style-type: none"> ▪ Measure power endurance over 4 hours (estimated talk time) using a 2 W CW signal — set the CW test signal frequency to the middle of the PCS Tx band (1880 MHz for PCS). ▪ Visually inspect device to ensure there is no damage to the antenna structure and matching components. ▪ VSWR / TIS / TRP measurements taken before and after this test must show similar results.

- a. These worst-case VSWR figures for the transmitter bands may not guarantee RSE levels to be within regulatory limits. The device alone meets all regulatory emissions limits when tested into a cabled (conducted) 50 Ω system. With antenna designs with up to 2.5:1 VSWR or worse, the radiated emissions could exceed limits. The antenna system may need to be tuned in order to meet the RSE limits as the complex match between the module and antenna can cause unwanted levels of emissions. Tuning may include antenna pattern changes, phase/delay adjustment, passive component matching. Examples of the application test limits would be included in FCC Part 22, Part 24 and Part 27, test case 4.2.16 for GSM (ETSI EN 301 511), and test case 4.2.2 for WCDMA (ETSI EN 301 908-1), where applicable.
- b. Antenna 1 — Primary (RF_MAIN), Antenna 2 — Secondary (RF_DIV) (Diversity)

3.4 GNSS

The AirPrime WP76XX includes Global Navigation Satellite System (GNSS) capabilities via the QUALCOMM IZat™ Gen8C Engine (formerly gpsOne), capable of operation in assisted and standalone GNSS modes (GPS / Galileo / GLONASS / BeiDou / QZSS).

Note: AirPrime WP76xx modules are not affected by the 2019 GPS week rollover. Software modifications extend the GPS rollover date to 12 December 2032.

3.4.1 GNSS Characteristics

The GNSS implementation supports GPS L1, Galileo E1, BeiDou-B1, QZSS and GLONASS L1 FDMA operation.

Table 3-53: GNSS Characteristics^a

Parameter		Value
Sensitivity ^b	Standalone or MS-based tracking sensitivity	-160 dBm
	Cold start acquisition sensitivity	-145 dBm
	MS-assisted acquisition sensitivity	-158 dBm
Accuracy in open sky (1 Hz tracking)		< 2 m CEP-50
Satellite channels available ^c	Acquisition	118
	Simultaneous tracking	40
Support for predicted orbits		Yes
Predicted orbit CEP-50 accuracy		5 m
Standalone Time To First Fix (TTFF)	Hot	1 s
	Warm	29 s
	Cold	32 s
Altitude (max)		18,2888 m (60,000 ft)
Velocity (max)		1,852 km/h (1150.8 mph)
Acceleration (max)		20 m/s ²
GNSS message protocols		NMEA
Recommended signal power for GPS input		Below -120 dBm
Maximum allowed GPS input		-116 dBm (if noise figure ≤ 3 is achieved)

- a. Acquisition / tracking sensitivity performance figures in conducted mode assume a 2.5 dB noise figure.
- b. GNSS sensitivity may degrade for modules installed in snap-in sockets.
- c. Resources are dynamically assigned and not constellation-specific.

3.4.2 GNSS Antenna Interface

The GNSS antenna interface is defined in [Table 3-54](#).

Table 3-54: GNSS Antenna Interface Pads

Pad	Name	Direction ^a	Function
37	GND		GNSS Antenna Ground
38	RF_GNSS	Input	GNSS Antenna Interface
39	GND		GNSS Antenna Ground
125	GND		GNSS Antenna Ground
128	GND		GNSS Antenna Ground

- a. Signal direction with respect to the module.

3.4.2.1 GNSS Antenna Recommendations

Table 3-55 defines the key characteristics to consider for antenna selection.

Table 3-55: GNSS Standalone Antenna Recommendations

Parameter	Recommendations	Notes
Frequency range	<ul style="list-style-type: none"> Wide-band GPS, Galileo, GLONASS, and BeiDou: 1559–1606 MHz recommended Narrow-band GPS and QZSS: 1575.42 MHz ± 2.046 MHz minimum 	
Field of view (FOV)	<ul style="list-style-type: none"> Omni-directional in azimuth -45° to +90° in elevation 	
Polarization (average Gv / Gh)	> 0 dB	Vertical linear polarization is sufficient.
Free space average gain (Gv+Gh) over FOV	> -6 dBi (preferably > -3 dBi)	Gv and Gh are measured and averaged over -45° to +90° in elevation, and ±180° in azimuth.
Gain	<ul style="list-style-type: none"> Maximum gain and uniform coverage in the high elevation angle and zenith. Gain in azimuth plane is not desired. 	
Average 3D gain	> -5 dBi	
Isolation between GNSS and RF Antenna	> 20 dB in all uplink bands	
Typical VSWR	< 2.5:1	
Polarization	Any other than LHCP (left-hand circular polarized) is acceptable.	Type of antenna and polarization (RHCP/linear) to be implemented is a matter of consideration based on specific end application.
Maximum voltage applied to antenna	6.3 VDC	
700 MHz harmonic ^a	< -56 dBm (input jammer 787.76 MHz at -25 dBm and measure the harmonic tone at 1575.42 MHz)	This specification is for B13 and B14 coexistence.
IIP2 ^a	> 45 dBm (Input jammers at 824.6 MHz with level -25 dBm and 2400 MHz with level -32 dBm and measure output IM2 at 1575.4 MHz)	Out of band
IIP3 ^a	> 2 dBm (Input jammers at 1712.7 MHz with level -20 dBm and 1850 MHz with level -65 dBm and measure output IM3 at 1575.4 MHz)	Out of band
Input 1 dB power compression point ^a	> -10 dBm	
Out of band rejection for an active antenna		
777–798 MHz	> 50 dB	
814–915 MHz	> 40 dB	50 dB is preferred
925–960 MHz	> 30 dB	50 dB is preferred

Table 3-55: GNSS Standalone Antenna Recommendations (Continued)

Parameter	Recommendations	Notes
1427–1463 MHz	> 35 dB	
1710–1785 MHz	> 35 dB	
1850–1980 MHz	> 40 dB	
2010–2025 MHz	> 40 dB	
2305–2315 MHz	> 40 dB	
2401–2483 MHz	> 40 dB	
2500–2570 MHz	> 35 dB	

a. For the LNA used by an active antenna

3.5 Electrical Specifications

This section provides details of the key electrical specifications of the AirPrime WP76XX embedded module.

3.5.1 Absolute Maximum Ratings

This section defines the absolute maximum ratings of the AirPrime WP76XX.

Warning: *If these parameters are exceeded, even momentarily, damage may occur to the device. In addition, extended application of Absolute Maximum Rating conditions to the device may reduce device reliability.*

Note: Operation above the maximum specified operating voltage (see Table 3-3 on page 32) is not recommended, and specified typical performance or functional operation of the device is neither implied nor guaranteed.

Table 3-56: Absolute Maximum Ratings

Parameter		Min	Typ	Max	Units
Power supply voltages					
VBAT_BB	Power Supply Input	0	-	6.0	V
VBAT_RF	Power Supply Input	0	-	5.5	V
VDD_Px (low-voltage (1.2V) operation)	Digital pad circuits	-0.5	-	1.44	V
VDD_Px (low-voltage (1.8V) operation)	Digital pad circuits	-0.5	-	2.3	V
VDD_Px (high-voltage (2.85V) operation)	Digital pad circuits	-0.5	-	3.35	V

Table 3-56: Absolute Maximum Ratings (Continued)

Parameter		Min	Typ	Max	Units
USB signal pins					
USB_D+	High-speed USB data plus	-	-	3.6	V
USB_D-	High-speed USB data minus	-	-	3.6	V
USB_VBUS	High-speed USB bus voltage	-	-	5.25	V
Thermal conditions					
TS	Storage temperature	-40		85	°C
TJ	Junction temperature	-	-	130	°C
Maximum voltage applied to antenna interface pins					
VANT	RF_MAIN	-		6.3	Vdc
	RF_DIV	-		6.3	Vdc
	RF_GNSS	-		6.3	Vdc
ESD ratings					
See EMC and ESD Recommendations on page 116.					

3.5.2 Digital I/O Characteristics

The I/O characteristics for supported digital interfaces are described in:

- [Table 3-57](#) — HSIC signals
- [Table 3-58](#) — GPIOs (except GPIO8 and GPIO28), UART, ANT_CNTL, TX_ON, and PCM/I²S signals
- [Table 3-59](#) — GPIO8 and GPIO28
- [Table 3-60](#) — SDIO and UIM signals

Table 3-57: Digital I/O Characteristics (V_{DD_PX} = 1.20 V (nominal))

Parameter	Comments	Min	Max	Units
V _{IH}	High level input voltage	0.65 × V _{DD_PX}	-	V
V _{IL}	Low level input voltage	-	0.35 × V _{DD_PX}	V
I _{IH}	Input high leakage current ^a	-	2	μA
I _{IL}	Input low leakage current ^b	-2	-	μA
V _{OH}	High level output voltage	0.75 × V _{DD_PX}	-	V
V _{OL}	Low level output voltage	-	0.25 × V _{DD_PX}	V
I _Z	Tri-state leakage current ^a	-2	2	μA
R _p	Pull resistance	17	60	kΩ
R _k	Keeper resistance	17	60	kΩ
C _{IN}	Input capacitance ^c	-	5	pF

- a. Pin voltage = V_{DD_PX} max.
- b. Pin voltage = GND and supply = V_{DD_PX} max.
- c. Input capacitance and I/O capacitance values are guaranteed by design, but is not 100% tested.

Table 3-58: Digital I/O Characteristics ($V_{DD_PX} = 1.80$ V (nominal) signals)

Parameter		Comments	Min	Max	Units
V_{IH}	High level input voltage	CMOS/Schmitt	$0.65 \times V_{DD_PX}$		V
V_{IL}	Low level input voltage	CMOS/Schmitt		$0.35 \times V_{DD_PX}$	V
V_{SHYS}	Schmitt hysteresis voltage		100	-	mV
I_{IH}	Input high leakage current ^a	No pull-down	-	1	μ A
I_{IL}	Input low leakage current ^b	No pull-up	-1	-	μ A
R_P	Pull up/down resistance		55	390	k Ω
V_{OH}	High level output voltage	CMOS, at pin-rated drive strength	$V_{DD_PX} - 0.45$		V
V_{OL}	Low level output voltage	CMOS, at pin-rated drive strength		0.45	V
R_K	Keeper resistance		30	150	k Ω
C_{IN}	Input capacitance ^c		-	5	pF
I_{PIN}	Current per pin		-	16	mA

- a. Pin voltage = V_{DD_PX} max. For keeper pins, pin voltage = V_{DD_PX} max - 0.45 V.
- b. Pin voltage = GND and supply = V_{DD_PX} max. For keeper pins, pin voltage = 0.45 V and supply = V_{DD_PX} max.
- c. Input capacitance is guaranteed by design, but is not 100% tested.

Table 3-59: GPIO8 and GPIO28 Digital I/O Characteristics ($V_{DD_PX} = 1.80$ V (nominal) signals)

Parameter		Comments	Min	Max	Units
V_{IH}	High level input voltage	CMOS/Schmitt	$0.65 \times V_{DD_PX}$		V
V_{IL}	Low level input voltage	CMOS/Schmitt		$0.35 \times V_{DD_PX}$	V
V_{OH}	High level output voltage	CMOS, at pin-rated drive strength	$0.8 \times V_{DD_PX}$		V
V_{OL}	Low level output voltage	CMOS, at pin-rated drive strength		$0.2 \times V_{DD_PX}$	V
R_P	Pull up/down resistance		10	50	k Ω
R_K	Keeper resistance		10	50	k Ω
I_{IH}	Input high leakage current ^a	No pull-down	-	1	μ A
I_{IL}	Input low leakage current ^b	No pull-up	-1	-	μ A
I_{PIN}	Current per pin		-	16	mA
V_{SHYS}	Schmitt hysteresis voltage		165	-	mV

- a. Pin voltage = V_{DD_PX} max.
- b. Pin voltage = GND and supply = V_{DD_PX} max.

Table 3-60: Digital I/O Characteristics (Dual-voltage — $V_{DD_PX} = 1.80\text{ V}$ or 2.85 V (nominal))

Parameter	Comments	Min	Max	Units	
Common to dual-voltage pads (1.8 V / 2.85 V)					
R_P	Pull resistance	Pull-up and pull-down	10	100	$k\Omega$
R_K	Keeper resistance		10	100	$k\Omega$
V_{SHYS}	Schmitt hysteresis voltage		100	-	mV
$C_{I/O}$	I/O capacitance		-	5	pF
Common to SDC pad and UIM pad at 2.85 V only					
I_{IH}	Input high leakage current	No pull-down	-	10	μA
I_{IL}	Input low leakage current	No pull-up	-10	-	μA
Common to UIM pads, 1.8V/2.85 V					
V_{IH}	High level input voltage	CMOS/Schmitt	$0.7 \times V_{DD_PX}$	$V_{DD_PX} + 0.3$	V
V_{IL}	Low level input voltage	CMOS/Schmitt	-0.3	$0.2 \times V_{DD_PX}$	V
V_{OH}	High level output voltage	CMOS, at pin-rated drive strength	$0.8 \times V_{DD_PX}$	V_{DD_PX}	V
V_{OL}	Low level output voltage	CMOS, at pin-rated drive strength	0	0.4	V
SDC pads at 2.85 V only					
V_{IH}	High level input voltage	CMOS/Schmitt	$0.625 \times V_{DD_PX}$	$V_{DD_PX} + 0.3$	V
V_{IL}	Low level input voltage	CMOS/Schmitt	-0.3	$0.25 \times V_{DD_PX}$	V
V_{OH}	High level output voltage	CMOS, at pin-rated drive strength	$0.75 \times V_{DD_PX}$	V_{DD_PX}	V
V_{OL}	Low level output voltage	CMOS, at pin-rated drive strength	0	$0.125 \times V_{DD_PX}$	V
Common to SDC pad and UIM pad at 1.8 V only					
I_{IH}	Input high leakage current ^a	No pull-down	-	2	μA
I_{IL}	Input low leakage current ^b	No pull-up	-2	-	μA
SDC pads at 1.8 V only					
V_{IH}	High level input voltage	CMOS/Schmitt	1.27	2	V
V_{IL}	Low level input voltage	CMOS/Schmitt	-0.3	0.58	V
V_{OH}	High level output voltage	CMOS, at pin-rated drive strength	1.4	-	V
V_{OL}	Low level output voltage	CMOS, at pin-rated drive strength	0	0.45	V

a. Pin voltage = V_{DD_PX} max

b. Pin voltage = GND and supply = V_{DD_PX} max

3.5.3 Internal Device Frequencies

Table 3-61 summarizes the frequencies generated within the AirPrime WP76XX. This table is provided for reference only to the device integrator.

Table 3-61: Internal Device Frequencies

Subsystem / Feature	Frequency	Units
Real Time Clock	32.768	kHz
PCM Audio Interface (PCM Master Mode)	<ul style="list-style-type: none"> ▪ 128 ▪ 2048 	kHz
I ² C Interface	100	kHz
PMIC switching power supplies	1.6	MHz
Fundamental clock	19.2	MHz
PLL	<ul style="list-style-type: none"> ▪ PLL0: 800.0000 ▪ PLL1: 614.4000 ▪ PLL2: 480.0000 ▪ PLL3: 600.6000 ▪ PLL4: 576.0000 ▪ PLL5: 691.2000 ▪ PLL6: Varies (1.2 GHz max) 	MHz
SPI	38	MHz
USB	480	Mb/s

3.6 Processing

3.6.1 Application Core

The Application Core is based on a Cortex A7 32-bit RISC architecture core. It has the following main characteristics:

- Up to 1.3 GHz operation
- Cache:
 - L1: Instruction (32 kB) and Data (32 kB)
 - L2: 256 kB

The Application Core supports Legato™, an open source embedded platform built on Linux, which allows the simultaneous safe running of multiple applications.

Refer to [Interfaces Specification](#) on page 81 for the list of interfaces supported by this core.

3.6.2 Embedded Memory

The AirPrime WP76XX module includes Flash and RAM embedded memory as detailed in [Table 3-62](#).

Refer to the latest customer release note for any changes regarding embedded memory.

Table 3-62: Embedded Memory Details

Type	Details	Size
Flash	Total	512 MB
	Reserved for Application processor	210 MB
	Minimum number of write cycles	100, 000
RAM	Total	256 MB
	Reserved for Application processor	128 MB

The application processor memory is dedicated to the Legato platform, including:

- Linux kernel
- Root file system
- Application framework
- Customer applications

3.6.2.1 Flash Memory

Flash memory is partitioned for use by various elements. Partitions mtd11–mtd13 can be used by the customer to install their custom Linux firmware, and mtd14 and mtd16 can be used to install custom Legato framework and custom Legato applications. The remaining partitions are reserved for internal use.

Partition: mtd0 ("sbl") Usage: System bootloader (Internal use)
Partition: mtd1 ("mibib") Usage: Internal use
Partition: mtd2 ("backup") Usage: Internal use
Partition: mtd3 ("security") Usage: Internal use
Partition: mtd4 ("persist") Usage: Internal use
Partition: mtd5 ("efs2") Usage: Internal use
Partition: mtd6 ("swifota") Usage: Internal use
Partition: mtd7 ("tz") Usage: Internal use
Partition: mtd8 ("devcfg") Usage: Internal use

Partition: mtd9 ("rpm") Usage: Internal use
Partition: mtd10 ("modem") Usage: Internal use
Partition: mtd11 ("about") Usage: Linux bootloader
Partition: mtd12 ("boot") Usage: Linux kernel
Partition: mtd13 ("system") Usage: Linux Root File System
Partition: mtd14 ("lefwkro") Usage: Legato application framework
Partition: mtd15 ("swirw") Usage: Internal use
Partition: mtd16 ("userapp") Usage: Legato customer application
Partition: mtd17 ("reserved") Usage: Internal use
Partition: mtd18 ("slot2") Usage: Internal use
Partition: mtd19 ("slot1") Usage: Internal use
Partition: mtd20 ("slot0") Usage: Internal use

Figure 3-6: Flash Memory Partitions

Follow these instructions to display partition sizes and to determine whether a customer firmware will fit:

1. Connect to the WP module.

2. Use Linux command `'cat /proc/mtd'`. Partition sizes are listed in the 'size' column.

```
root@swi-mdm9x28-wp:~# cat /proc/mtd
dev: size erasesize name
mtd0: 00280000 00040000 "sbl"
mtd1: 00280000 00040000 "mibib"
mtd2: 00680000 00040000 "backup"
mtd3: 00100000 00040000 "security"
mtd4: 00200000 00040000 "persist"
mtd5: 01180000 00040000 "efs2"
mtd6: 04f40000 00040000 "swifota"
mtd7: 00180000 00040000 "tz"
mtd8: 000c0000 00040000 "devcfg"
mtd9: 000c0000 00040000 "rpm"
mtd10: 02000000 00040000 "modem"
mtd11: 00100000 00040000 "aboot"
mtd12: 00f00000 00040000 "boot"
mtd13: 01e00000 00040000 "system"
mtd14: 008c0000 00040000 "lefwkro"
mtd15: 01900000 00040000 "swirw"
mtd16: 08300000 00040000 "userapp"
mtd17: 03680000 00040000 "reserved"
mtd18: 02180000 00040000 "slot_2"
mtd19: 02180000 00040000 "slot_1"
mtd20: 02180000 00040000 "slot_0"
```

3. When building an image, use the `swicwe` command to display the sizes of the image components to ensure that they can fit in the associated partitions. For example, using WP76xx Release 12 Linux/Yocto (linux-SWI9X07Y_02.25.02.01.cwe) and Legato (legato-18.10.3.cwe) image components:

```
myname@mysystem$swicwe -P linux-SWI9X07Y_02.25.02.01.cwe
Type Size(Exclude Header) Product Compress Version
*APPL 32075352 Y921 0 SWI9X07Y_02.25.02.01 000000 CARMD-EV-SIGN01 2019/01/30 17:38:52
HASH 6560 9X28 0 SWI9X07Y_02.25.02.01 000000 CARMD-EV-SIGN01 2019/01/30 17:38:52
*APBL 528188 9X28 0 SWI9X07Y_02.25.02.01 000000 CARMD-EV-SIGN01 2019/01/30 17:38:52
*SYST 22282240 Y921 0 SWI9X07Y_02.25.02.01 000000 CARMD-EV-SIGN01 2019/01/30 17:38:52
*APPS 9256764 9X28 0 SWI9X07Y_02.25.02.01 000000 CARMD-EV-SIGN01 2019/01/30 17:38:52

myname@mysystem$swicwe -P legato-18.10.3.cwe
Type Size(Exclude Header) Product Compress Version
*APPL 4981136 Y921 0 18.10.3 5926bf8 jenkins 2019/02/08 19:10:30
*USER 4980736 9X28 0 18.10.3 5926bf8 jenkins 2019/02/08 19:10:30
```

Refer to the following table for component details.

Component	Description	Partition Storage Location
APBL	Yocto lk bootloader	mtd11 ("aboot")
APPS	Yocto kernel	mtd12 ("boot")
SYST	Yocto RootFS	mtd13 ("system")
USER	Legato framework	mtd14 ("lefwkro")

3.6.2.2 RAM

To display the amount of RAM currently available for use by customer applications, connect to the WP module and use Linux command `'cat /proc/meminfo'`.

The total available RAM for application usage is given after the **MemAvailable** label.

```

root@swi-mdm9x28-wp:~# cat /proc/meminfo
MemTotal:          158652 kB
MemFree:           3408 kB
MemAvailable:    80756 kB
Buffers:           38896 kB
Cached:            37964 kB
SwapCached:        0 kB
Active:            66272 kB
Inactive:          39936 kB
Active(anon):      29384 kB
Inactive(anon):    2044 kB
Active(file):      36888 kB
Inactive(file):    37892 kB
Unevictable:       0 kB
Mlocked:           0 kB
SwapTotal:         0 kB
SwapFree:          0 kB
Dirty:             0 kB
Writeback:         0 kB
AnonPages:         29360 kB
Mapped:            12072 kB
Shmem:             2080 kB
Slab:              26236 kB
SReclaimable:     8412 kB
SUnreclaim:       17824 kB
KernelStack:      2696 kB
PageTables:        1704 kB
NFS_Unstable:     0 kB
Bounce:           0 kB
WritebackTmp:     0 kB
CommitLimit:      79324 kB
Committed_AS:     1259228 kB
VmallocTotal:     761856 kB
VmallocUsed:       35996 kB
VmallocChunk:     724724 kB

```

Semtech recommends that customer applications do not consume more than 55MB of RAM to provision for future expansion of the modem software, protocol stack and Legato framework in the next two years.

3.6.3 Recovery Mechanism

The AirPrime WP76xx has the capability to automatically detect and recover from various corruption scenarios (for example, corruption may occur when power is abruptly removed from the module).

A backup of the configuration stored in the file system is created before WP76xx modules leave the Semtech factory. The file system backup can be updated at customer factories using **AT+INVBACKUP**. If a file system corruption is detected, the stored backups are checked and the most recent backup is automatically restored.

To avoid the potential for memory corruption, make sure to always follow the proper power off procedure before removing power from the module. (Figure 4-1 on page 82 illustrates the signal timing details for powering off the module.)

3.6.4 Secure Boot / Secure Debug

- AirPrime WP76xx modules incorporate the following permanently enabled features to enhance device security:
- Secure Boot—Ensures only firmware images signed by Semtech can be loaded and run on WP76xx modules. Specifically, Secure Boot applies to the following firmware components: system boot loader, carrier configuration, and telecom FW.
 - Secure Debug—Disables debug features such as RAM dump collection and JTAG access to the module.

For additional details, refer to the WP Series Secure Boot and Secure Debug application notes available on <http://source.sierrawireless.com>.

3.7 Mechanical Drawing

The AirPrime WP76XX module’s LGA footprint is a 239-pad array of copper pads (see [Physical Dimensions and Connection Interface](#) on page 20). The following drawing illustrates the device footprint and dimensions.

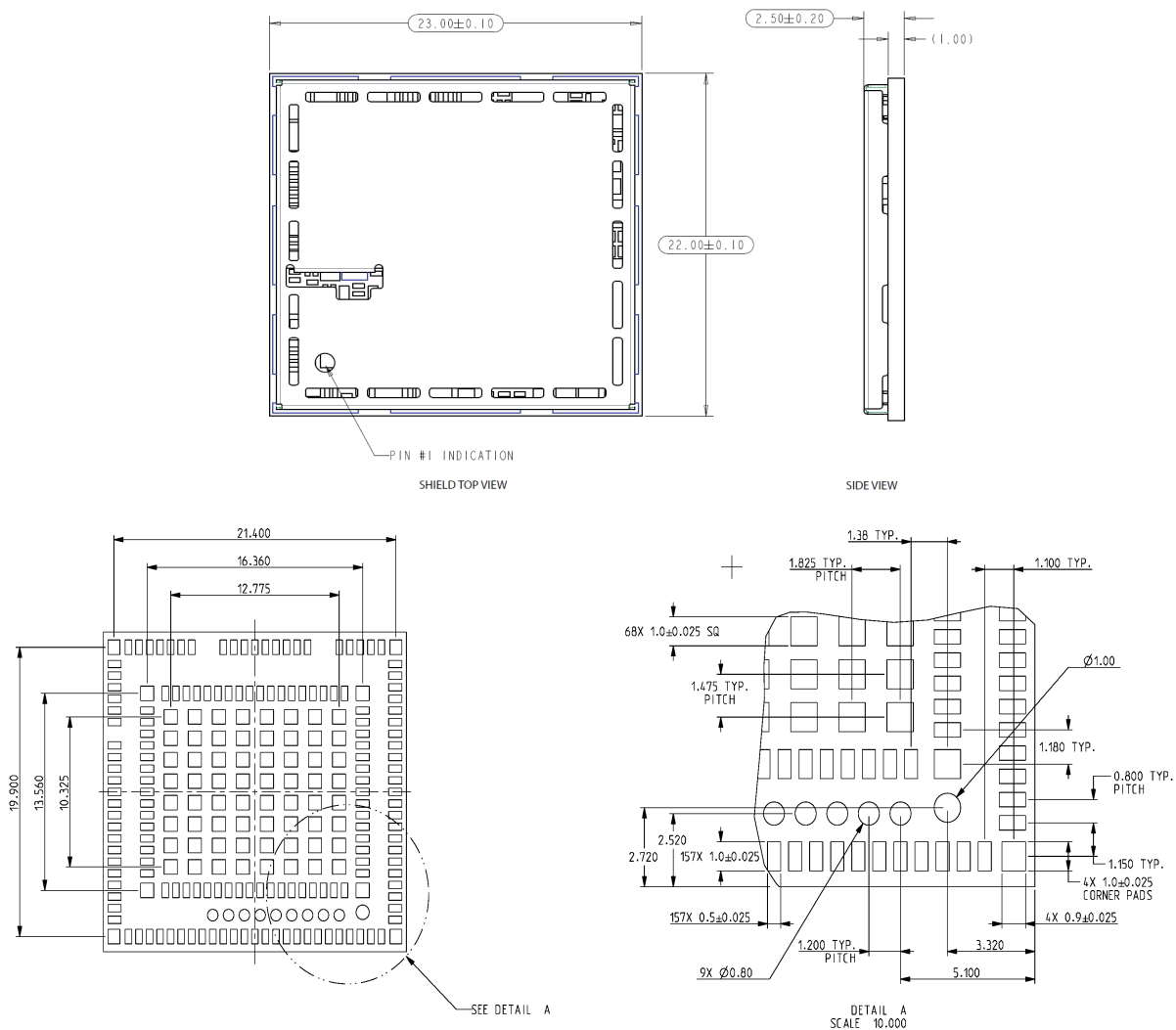


Figure 3-7: WP7601/WP7603 Mechanical Drawing

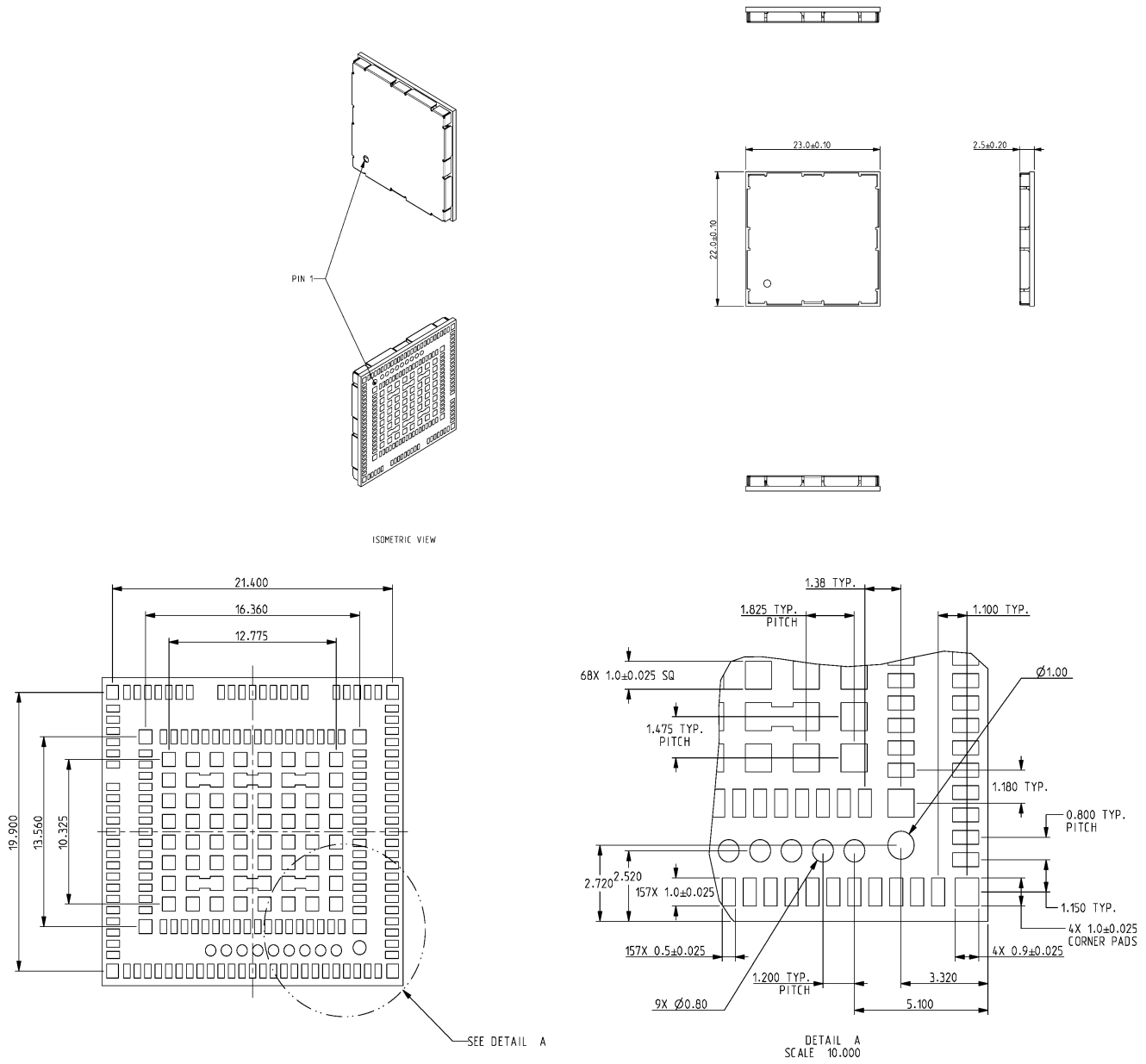


Figure 3-8: WP7605/WP7607/WP7608/WP7609/WP7610 Mechanical Drawing

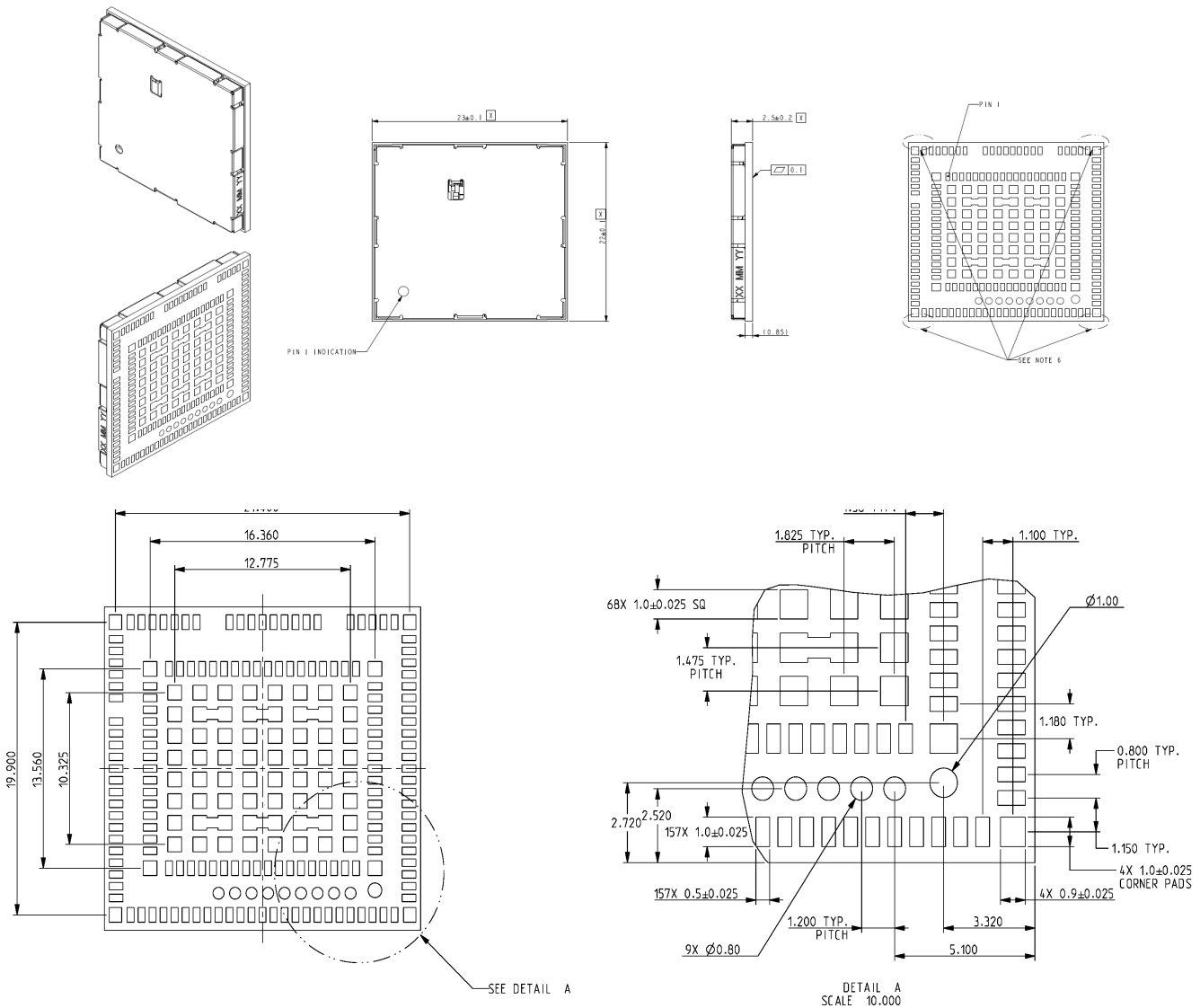


Figure 3-9: WP7611, WP7611D Mechanical Drawing

3.8 Mechanical Specifications

The following table describes additional mechanical specifications for the AirPrime WP76XX module.

Table 3-63: Mechanical Specifications

Specification	Value	Notes
Clamping force	20 psi	Maximum clamping force on module over entire shield surface.

4: Interfaces Specification

4.1 Overview

This section describes the interfaces supported by the AirPrime WP76XX embedded module and provides specific voltage, timing, and circuit recommendations for each interface.

4.2 POWER_ON_N

The AirPrime WP76XX module requires a low level signal (POWER_ON_N) that is used to switch the module ON.

The signal is connected internally to the permanent 1.8V supply regulator inside the module via a pull-up resistor. Once VBAT_BB is supplied to the module, this 1.8V supply regulator will be enabled and so the POWER_ON_N signal is by default at high level.

Important: Use a momentary switch to control this line to reduce leakage current in ULPM mode. Holding POWER_ON_N low in ULPM mode incurs a significant current draw—see [Table 3-17](#) on page 52 for details.

[Table 4-1](#) describes the POWER_ON_N signal's characteristics.

Table 4-1: POWER_ON_N Electrical Characteristics^a

Parameter	Min	Typ	Max	Units
Input Voltage— Low	-	-	0.67	V
Internal pull-up resistor	150	200	250	kΩ
POWER_ON_N assertion time ^b	200			ms

a. When floating, voltage will be approximately 800 mV.

b. Assertion time is the time required to keep POWER_ON_N at LOW level to ensure the module can be powered ON successfully.

4.2.1 Power-up Sequence

4.2.1.1 Power On/Off Timing

Note: The host should not drive any signals to the module until the VGPIO rises (approximately 100 ms after power up). Before reaching the Active state, host signals must be set to floating, high impedance, or input pull-down; this also applies when the module is in reset mode, during a firmware update, or during a power-off sequence. The host must consider these signal settings when designing the module interface.

Figure 4-1 describes the timing sequence for powering the module on and off.

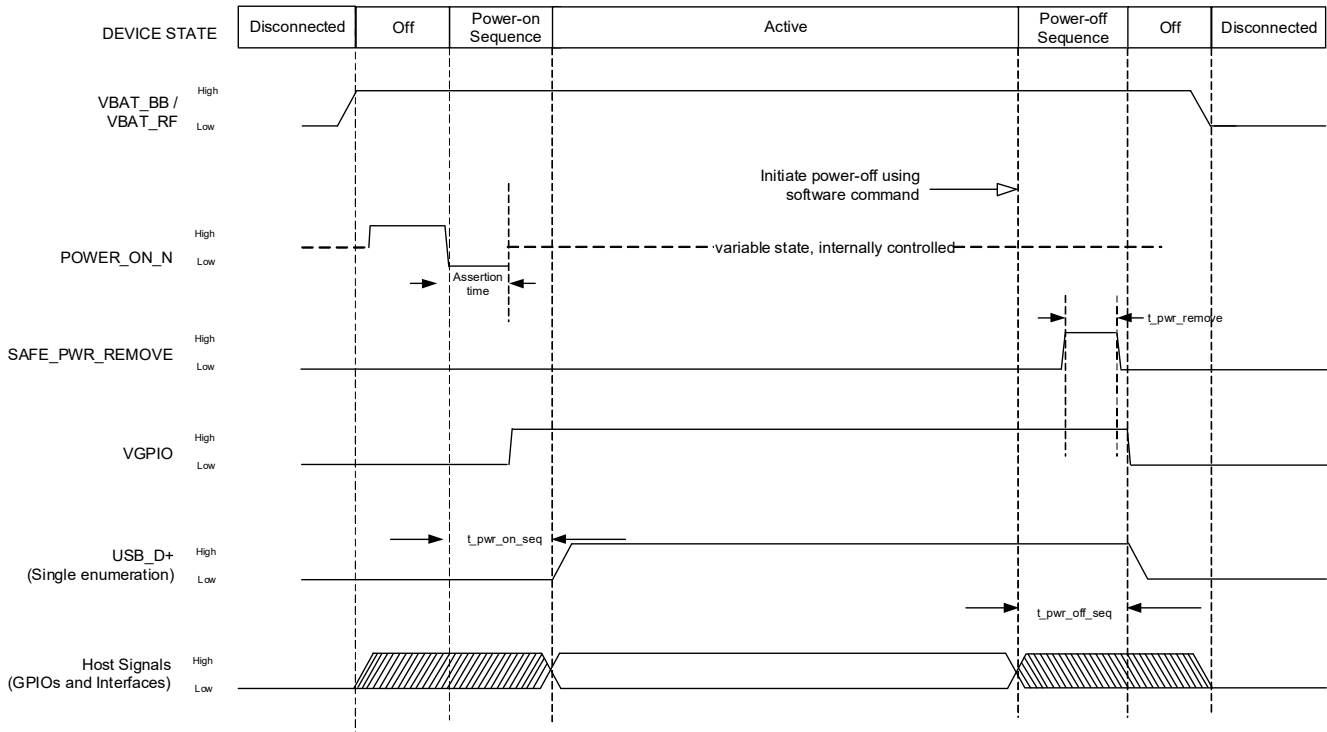


Figure 4-1: Signal Timing (POWER_ON_N, and USB Enumeration)

Table 4-2: POWER_ON_N Timing Parameters

Parameter	Typical	Maximum	Units
$t_{pwr_on_seq}$	15	24 ^a	s
$t_{pwr_off_seq}$	0.4–5.5	8	s
t_{pwr_remove}	13	-	ms

a. Value is based on disabled custom parameters "HSICENABLE" and "BOOTQUIETDISABLE". Note that there will be an increase in value if either of these custom parameters are enabled.

4.2.1.2 USB Enumeration

The unit supports single USB enumeration with the host. Enumeration starts within (maximum) $t_{pwr_on_seq}$ seconds of power-on.

4.2.2 Software-Initiated Power Down

To power down the module via software:

1. Initiate the power down process:
AT+POWERDOWN
2. Monitor VGPIO.
3. When VGPIO is low, remove power.

4.3 Emergency Power Off

The module can be switched off by controlling the RESET_IN_N pin. This must only be used in emergency situations if the system freezes (not responding to commands).

To perform an emergency power off:

1. De-assert POWER_ON_N.
2. While POWER_ON_N is de-asserted, assert RESET_IN_N (logic low) for at least 8 s. This immediately powers down the module.

4.3.1 Software Reset

Perform a modem reset. It is also recommended to use AT!RESET for a software reset.

4.4 POWER_ON_N, RESET_IN_N and AT!POWERDOWN Use Cases

Table 4-3 lists the behavior of the WP76xx depending on POWER_ON_N, RESET_IN_N and AT!POWERDOWN use cases.

Table 4-3: POWER_ON_N, RESET_IN_N and AT!POWERDOWN Use Cases

Use Case		Group A Variants	Group B Variants
POWER_ON_N ^a	VBATT is applied then POWER_ON_N is asserted	Turns ON	Turns ON
	POWER_ON_N is asserted then VBATT is applied	Turns ON	Turns ON
RESET_IN_N ^b	POWER_ON_N is left asserted then RESET_IN_N is asserted	Resets	Resets
	POWER_ON_N is de-asserted then RESET_IN_N is asserted	Emergency OFF	Resets
	POWER_ON_N is de-asserted then RESET_IN_N is asserted with a long pulse (>8 sec)	Emergency OFF	Emergency OFF
AT!POWERDOWN AT Command	POWER_ON_N is asserted then the power OFF command is sent	Turns OFF	Restarts
	POWER_ON_N is de-asserted then the power OFF command is sent	Turns OFF	Turns OFF

- a. When using Group A variants, this pin must not be toggled or pulsed when the module is already booted and operational. Doing so will lead to the module resetting or turning OFF.
- b. This pin should only be used for emergencies such as when the module stops responding to AT commands.

4.5 Tx Power Control

The module's Tx power limit may be controlled using the following methods:

- SAR backoff AT commands (see document [1] AirPrime WP8548/WP75xx/WP76xx/WP77xx AT Command Reference):
 - ISARSTATEDFLT — Set (or report) the default SAR backoff state that the device uses when it powers up. This setting is persistent across power cycles and overrides any PRI setting.
 - ISARSTATE — Set (or report) the current SAR backoff state (override the default state). This change in state is non-persistent across power cycles.

- !SARBACKOFF — Set (or report) the maximum Tx power limit for a specific band / technology / state combination.
- Legato commands:
 - le_mrc_GetSarBackoffState() — Get the current SAR Backoff state.
 - le_mrc_SetSarBackoffState() — Set the current SAR Backoff state (override the default state). This change is non-persistent across power cycles.
- GPIO control via !SARGPIO command (see [1] AirPrime WP8548/WP75xx/WP76xx/WP77xx AT Command Reference)—Set an unallocated external GPIO to control SAR.

4.6 USB

The AirPrime WP76XX implements a high-speed USB 2.0 Interface, which conforms to the *Universal Serial Bus Specification, Revision 2.0*.

Table 4-4: USB Pin Descriptions

Pin	Signal name	Direction ^a	Function
12	USB_D-	Input/Output	Differential data interface negative
13	USB_D+	Input/Output	Differential data interface positive
16	USB_VBUS	Input	USB supply voltage
91	USB_ID	Input	Used for USB_OTG

a. Signal direction with respect to the module. Example: USB_ID is an input to the module from the host.

4.7 UART

The AirPrime WP76XX provides two UART interfaces:

- UART1 (primary UART) — 8-wire interface
- UART2 (secondary UART) — 4-wire interface

The UART interfaces are used for data communication between the AirPrime WP76XX module and a PC or host processor. These interfaces comply with the RS-232 interface.

Flow control is managed using the UART2_RTS and UART2_CTS signals.

Table 4-5 on page 85 describes the signals used for UART1 and UART2.

Note: UART signals are named with respect to the host device, and directions are listed with respect to the module. For example, UART1_RX is an output from the module to the host. WIFI coex and 8-wire UART concurrency is not supported.

Table 4-5: UART Pins

Pin	Interface	Name ^a	Direction ^b	Function	If unused	Notes
2	UART1	UART1_RI	Output	Ring Indicator Signal incoming calls (voice and data), SMS, etc.	Leave open	<i>Note: Do not install external pull-up on this pin, otherwise the module will not boot.</i>
3		UART1_RTS	Input	Ready To Send	Leave open	
4		UART1_CTS	Output	Clear To Send	Leave open	
5		UART1_TX	Input	Transmit Data	Leave open	
6		UART1_RX	Output	Receive Data	Leave open	
7		UART1_DTR ^c	Input (active low)	Data terminal ready Prevents the WP76XX from entering USB-SS mode, switches between data mode and command mode, and wakes the module.	Leave open	
8		UART1_DCD	Output	Data Carrier Detect Signal data connection in progress	Leave open	<i>Note: Do not install external pull-up on this pin, otherwise the module will not boot.</i>
9	UART1_DSR	Output	Data Set Ready Signal UART interface is ON	Leave open	<i>Note: Do not install external pull-up on this pin, otherwise the module will not boot.</i>	
96	UART2	UART2_TX	Input	Transmit data	Leave open	
97		UART2_RX	Output	Receive data	Leave open	
98		UART2_RTS	Input	Ready To Send, flow control	Leave open	
99		UART2_CTS	Output	Clear To Send, flow control	Leave open	

- a. Signals are named with respect to the host device. For example, UART1_RX is the signal used by the host to receive data from the module.
- b. Signal direction with respect to the module. For example, UART1_RX is an output from the module to the host.
- c. Pin is 'wakeable'. Can be used to trigger the module to wake up from USB-SS mode (low power active state). See [Wakeup Interrupt \(Sleep State\)](#) on page 90 for details.

4.8 UIM Interface

The AirPrime WP76XX has two physical UIM interfaces:

- UIM1 — this interface allows control of external 1.8V/3V UIMs.
- UIM2 — this interface is used to control an eSIM on selected variants.

Note: UIM1 and UIM2 cannot be activated simultaneously (DSSS—dual SIM single standby).

4.8.1 External UIM1 Interface

Table 4-6 describes the signals used for UIM1.

Table 4-6: UIM Interface Pins

Pin	Interface	Name	Direction ^a	Function	If Unused
26	UIM1	UIM1_VCC	Output	Supply output	Leave open
27		UIM1_CLK	Output	Clock	Leave open
28		UIM1_DATA	Input/Output	Data connection	Leave open
29		UIM1_RESET_N	Output	Reset	Leave open
64		UIM1_DET ^b	Input	Detect UIM	Leave open

- Signal direction with respect to the module. Examples: UIM1_DET (pin 64) is an input to the module from the host; UIM1_RESET_N (pin 29) is an output from the module to the host.
- Pin is 'wakeable'. Can be used to trigger the module to wake up from USB-SS mode (low power active state). See [Wakeup Interrupt \(Sleep State\)](#) on page 90 for details.

Figure 4-2 illustrates the recommended implementation of a UIM holder. (For a more detailed UIM schematic, see Figure 5-4 on page 117.)

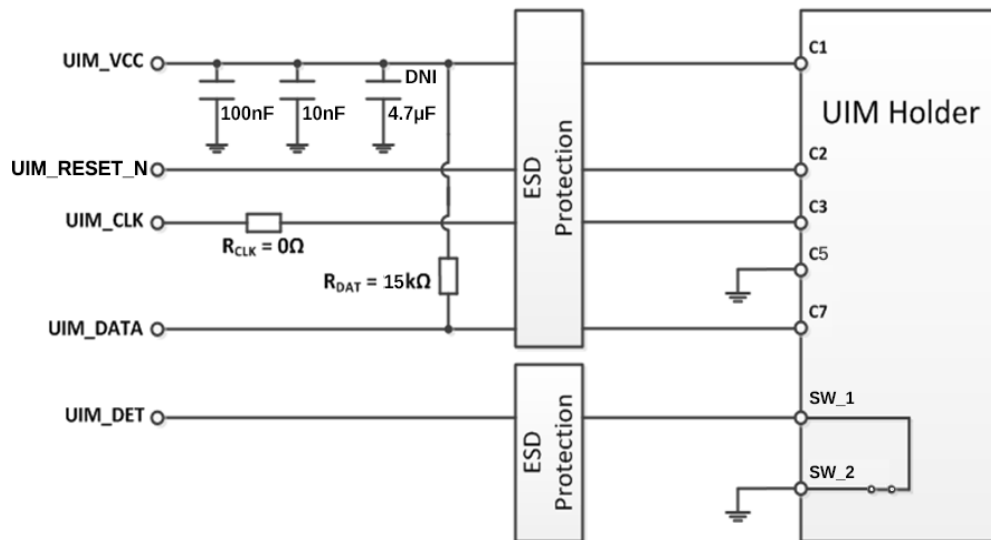


Figure 4-2: Recommended UIM Holder Implementation

The UIM Detect signal (UIM1_DET) is used to detect the physical presence of a UIM card in the UIM holder. The signal has a pull-up internal to the AirPrime WP76XX. It should be set to GND when a UIM is not present. All signals near the UIM holder must be ESD-protected.

The UIM Detect signal transitions:

- When a UIM is inserted — high (logic 0 to logic 1)
- When a UIM is removed — low (logic 1 to logic 0)

The capacitor and the two resistors, RCLK and RDAT, should be added as placeholders to compensate for potential layout issues. UIM_DATA trace should be routed away from the UIM_CLK trace. Keep the distance between the module and the UIM holder as short as possible.

An ESD device specifically designed for UIM cards is recommended for the UIM1 VCC, RESET_N, CLK, and DATA signals (for example, STMicroelectronics DALC208SC6). For UIM1_DET a low leakage ESD suppressor should be selected.

4.8.2 eSIM / UIM2 Interface

When an eSIM is mounted on an AirPrime WP76XX, UIM2 signals are directly connected to the eSIM and are not available externally.

Selection of active SIM between UIM1 (external SIM) and UIM2 (eSIM) is possible using AT commands **AT!UIMS** and **AT!CUSTOM="UIMAUTOSWITCH"**. Refer to document [1] AirPrime WP8548/WP75xx/WP76xx/WP77xx AT Command Reference for more details regarding these commands.

When UIM2 is deselected, the eSIM component is unpowered.

4.8.3 External SIM Switch Configuration

The UIM1 interface can be used with either a single external SIM, or with two external SIMs, using an external switch. The external switch is controlled by GPIO6 (pin 46), and GPIO4 is used to detect the second external SIM.

1 external SIM card

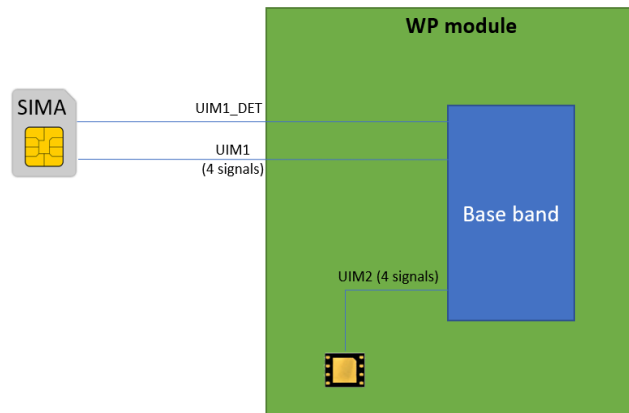


Figure 4-3: Single External SIM Configuration

2 external SIM cards (with 2 dedicated SIM detects)

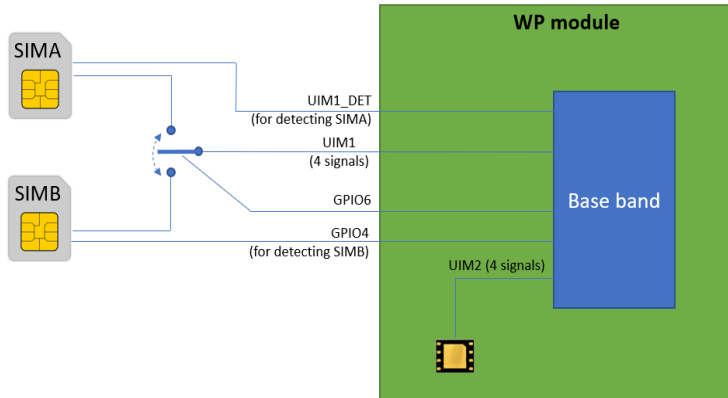


Figure 4-4: Dual External SIM Configuration

4.9 General Purpose Input/Output (GPIO)

The AirPrime WP76XX defines several GPIOs for customer use, as described in [Table 4-7](#). For electrical specifications, see [Table 3-58](#) on page 71 and [Table 3-59](#) on page 71.

Note: In ULPM, all interfaces connected to GPIOs (see [Table 4-7](#) on page 88) must be tri-stated or off to prevent additional leakage current during ULPM and potentially damaging the unit by applying a voltage when the GPIOs are off.

Similarly, there should not be any voltage applied to the GPIOs when the module is off to prevent damaging the module.

All GPIOs are in undefined state during reset.

Table 4-7: GPIO Pin Description

Pin	Signal Name	Configurable as Wakeup Trigger for ULPS ^a	Default State	Function	If Unused
10	GPIO2		No pull ^b	General purpose I/O	Leave open
40	GPIO7				
41	GPIO8				
44	GPIO13				
46	GPIO6 ^c				
65	GPIO4				
92	GPIO38 ^{d,e}	Yes			
94	GPIO40 ^{d,e}				
95	GPIO41 ^{d,e}				

Table 4-7: GPIO Pin Description (Continued)

Pin	Signal Name	Configurable as Wakeup Trigger for ULPS ^a	Default State	Function	If Unused
101	GPIO35		No pull ^b	General purpose I/O	Leave open
102	GPIO36 ^{d,e}	Yes			
103	GPIO37 ^{d,e}				
104	GPIO32				
105	GPIO33				
109	GPIO42				
147	GPIO21				
148	GPIO22				
149	GPIO23				
150	GPIO24				
153	GPIO28 ^f				
154	GPIO29 ^f				
155	GPIO30 ^f				
156	GPIO31 ^f				
159	GPIO25				

- a. See [Power Consumption States](#) on page 33 and [Wakeup Events \(ULPS\)](#) on page 91 for details.
- b. Internal configuration of all GPIOs—no internal pull-ups.
- c. See [GPIO6](#) on page 89
- d. Accessible via sysfs/Legato only.
- e. Only available in Group A variants; this pin is Reserved in Group B variants.
- f. This pin is available for use when configured using AT+WIOCFG.

See [Wakeup Interrupt \(Sleep State\)](#) on page 90 to see which GPIOs can be used to trigger the module to wake up from USB-SS mode (low power active state).

4.10 GPIO6

GPIO6 can be used for three different functions as described below. Refer to the AirPrime WP8548/WP75xx / WP76xx/WP77xx AT Command Reference for AT command details to configure GPIO6.

4.10.1 General Purpose Input / Output

To configure this pin as a GPIO:

- If the external SIM switch is enabled (see Section 4.10.2), disable the feature using **AT!CUSTOM="EXTUIMSWITCHEN",0** then, reboot the module. If the external SIM switch is not enabled, skip to step 2.
- Check the configuration of GPIO6 using **AT+WIOCFG?6**.
- If required, change the configuration using **AT+WIOCFG=6,<value>**, and reboot the module.

4.10.2 SIM Switching

To use this pin for fast SIM switching, enable the feature using **AT!CUSTOM="EXTUIMSWITCHEN",1**.

4.10.3 Reset Out

This pin can be used to provide a signal that will hold peripheral devices (such as a USB hub, I²C device, etc.) in reset until the power-up sequence is complete.

To configure this pin as Reset:

1. Disable external SIM switch feature using **AT!CUSTOM="EXTUIMSWITCHEN",0**.
2. Configure GPIO6 using **AT+WIOCFG=6,0**.
3. Reboot the module.

When the module is:

- In reset or powering up — this pin is held low to put peripheral devices in reset. Once the power-on sequence is complete, this pin will be turned high to take the peripherals out of reset.
- In ULPM — this pin will be floating. A default pull-up or pull-down may be necessary depending on the application.

4.11 Wakeup Interrupt (Sleep State)

The following pins can be used to wake the device when it is in Sleep state (low-power state):

- GPIO2
- GPIO4
- GPIO7
- GPIO13
- GPIO21
- GPIO22
- GPIO24
- GPIO35
- GPIO36 (only available in Group A variants)
- GPIO37 (only available in Group A variants)
- GPIO38 (only available in Group A variants)
- GPIO42
- UART1_DTR
- UIM1_DET

The GPIO pins can be configured as a wakeup source by using the AT+WIOCFG command (see [1] **AirPrime WP8548/WP75xx/WP76xx/WP77xx AT Command Reference**).

If the device firmware is monitoring these pins while the device is in USB-SS mode, any transition on these pins will wake the device. (Note: The UIM1_DET pin transitions high when a UIM is installed, and low when a UIM is removed.)

Note: These signals wake the device when it is in Sleep state (a low-power ACTIVE state where the module is fully powered). If the device is in ULPS, it is woken by configured wakeup triggers—see Table 4.12, Wakeup Events (ULPS), on page 91 for details.

4.12 Wakeup Events (ULPS)

The following signals/sources can be used to wake the device from ULPS:

Table 4-8: ULPS Wakeup Signals/Sources

Signal Configuration	Signal
Configurable	Timer
	GPIO36 ^a , GPIO38 ^a
	ADC2 ^a
	ADC3 ^a
Always enabled	POWER_ON_N

a. Only available in Group A variants.

Note: These signals wake the device only when it is in ULPS. If the device is in Sleep state (a low-power ACTIVE state where the module is fully powered), it can be woken using the signals described in [Wakeup Interrupt \(Sleep State\)](#) on page 90.

For ULPS details, see [Table 3-5, Supported Power States](#), on page 34.

4.13 Secure Digital IO (SDIO) Interface

The AirPrime WP76XX module defines a 1.8 V/2.85 V SDIO interface (SD 2.0-compliant) for customer-defined use with SD cards, connection to a Wi-Fi module, etc.

Note: An external 1.8 V/2.85 V supply is required to supply power to the SD card.

[Table 4-9](#) describes the signals used for SDIO.

Table 4-9: SDIO Pin Descriptions

Pin	Signal Name	Direction ^a	Description	If unused	Voltage level
161	SDIO_CMD	Output	SDIO command	Leave Open	1.8 V/2.85 V
162	SDIO_CLK	Output	SDIO clock	Leave Open	
163	SDIO_DATA_3	Input/Output	SDIO data bit 3	Leave Open	
164	SDIO_DATA_2	Input/Output	SDIO data bit 2	Leave Open	
165	SDIO_DATA_1	Input/Output	SDIO data bit 1	Leave Open	1.8 V/2.85 V
166	SDIO_DATA_0	Input/Output	SDIO data bit 0	Leave Open	

a. Signal direction with respect to the module. Example: SDIO_CMD (pin 161) is an output from the module to the host.

4.14 I²C Interface

The AirPrime WP76XX module provides one I²C (Inter-Integrated Circuit) dedicated serial port (bus interface) based on [6] I2C Bus Specification, Version 2.1, January 2000.

The interface uses the pins indicated in [Table 4-10](#).

Table 4-10: I²C Interface Pins

Pin	Signal name	Direction	Function	If Unused
1	I2C1_CLK	Input/Output	I ² C Clock	Leave open
66	I2C1_DATA	Input/Output	I ² C Data	Leave open

This implementation of the I²C interface includes the following characteristics:

- Supported voltage — 1.8 V
- Standard-mode interface — Data transfer rates up to 100 kbit/s
- Master mode operation only — WP76XX module always operates as the master
- I²C signals are implemented internally as open drain outputs (per the I²C specification) with 2.2 k Ω pull-up resistors to VGPIO (see [Figure 4-5](#) on page 92).

Note: I²C slave addresses 0x10 and 0x3a are reserved for internal use.

For I²C bus details, including I2C bus waveform and timing details, refer to the I2C Bus Specification.

4.14.1 Application

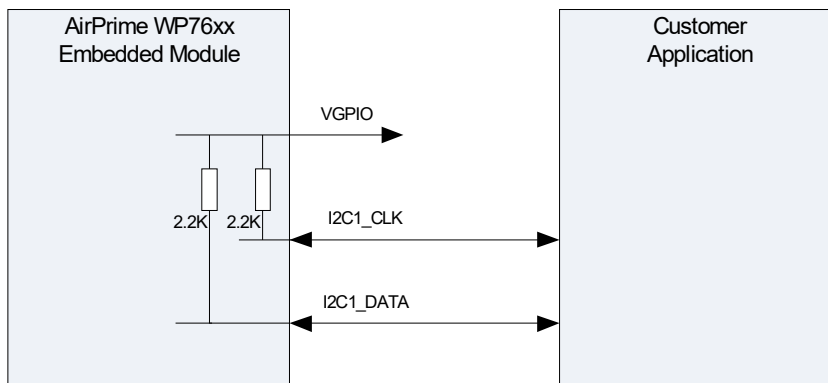


Figure 4-5: Example of I²C Bus Application

4.15 VGPIO

The AirPrime WP76XX utilizes 1.8V logic, provided via the VGPIO (GPIO voltage output) pin.

Table 4-11: VGPIO Reference Pin

Pin	Signal Name	Direction ^a	Function	If Unused
45	VGPIO	Output	GPIO voltage output	Leave open

a. Signal direction with respect to the module — VGPIO (pin 45) is an output from the module to the host.

Table 4-12: VGPIO Electrical Characteristics

Parameter	Min	Typ	Max	Unit	Remarks
Voltage level	1.7	1.8	1.9	V	Applies to active mode and USB-SS mode
	-	-	-	V	Off in ULPM
Current capability	-	-	50	mA	Power Management support up to 50 mA output

The VGPIO pin is available when the module is in Active power state, and can be used to:

- Pull up GPIOs
- Supply external digital transistors driving LEDs
- Act as a voltage reference for the ADC interfaces — ADC0–ADC3

Note: VGPIO is floating (not available) when the module is OFF or in ULPS.

4.16 Reset Signal (RESET_IN_N)

The AirPrime WP76XX provides an interface to allow an external application to reset the module.

Table 4-13: RESET_IN_N Pin

Pin	Signal Name	Direction ^a	Function	If Unused
11	RESET_IN_N	Input	External Reset Input	Leave open

a. Signal direction with respect to the module — RESET_IN_N (pin 11) is an input to the module from the host.

The RESET_IN_N signal is internally pulled-up with an internal resistor. An open collector transistor or equivalent should be used to ground the signal when necessary to reset the module.

To reset the module, a low level pulse must be sent on the RESET_IN_N pin for 32 ms. This will immediately restart the module with the POWER_ON_N signal at low level. (If the POWER_ON_N signal is at high level, the module will be powered off.)

The RESET_IN_N signal will reset the registers of the CPU and reset the RAM memory as well, for the next power on.

Note: Using RESET_IN_N to reset the module could result in memory corruption if used inappropriately. This signal should only be used if the module has become unresponsive and it is not possible to perform a power cycle.

Table 4-14: Reset Timing

Symbol	Parameter	Min	Typ	Max
Trdet	Duration of RESET_IN_N signal before firmware detects it (debounce timer)	-	32 ms	-
Trlen	Duration reset asserted	42 ms	-	∞
Trdel	Delay between minimum Reset duration and internal reset generated	-	500 ms	-

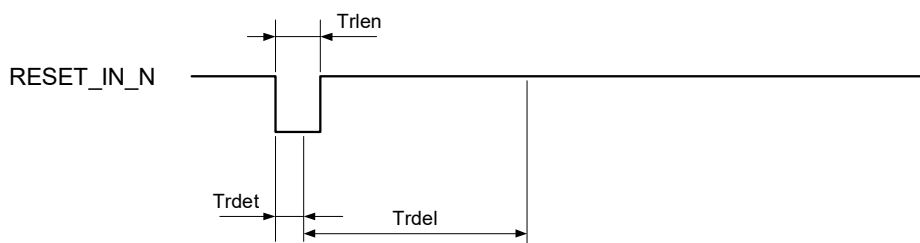


Figure 4-6: Illustration of Reset Timing When RESET_IN_N < Trdel

4.17 ADC

The AirPrime WP76XX provides four general purpose ADC (Analog to Digital Converter) inputs, as described [Table 4-15](#) and [Table 4-16](#).

Table 4-15: ADC Interface Pins

Pin	Signal Name	Direction ^a	Function	If Unused
24	ADC1	Input	Analog to Digital Converter	Leave open or Ground
25	ADC0	Input	Analog to Digital Converter	Leave open or Ground
107	ADC2 ^{b,c}	Input	Analog to Digital Converter	Leave open or Ground
108	ADC3 ^{b,c}	Input	Analog to Digital Converter	Leave open or Ground

- a. Signal direction with respect to the module. Example: ADC1 (pin 24) is an input to the module from the host.
- b. Pin is 'wakeable'. Can be used to trigger the module to wake up from ULPM mode. See [Wakeup Events \(ULPS\)](#) on page 91 for details.
- c. Only available in Group A variants; this pin is Reserved in Group B variants.

Table 4-16: ADC Interface Characteristics

	ADC0 / ADC1 Value	ADC2 / ADC3 Value ^a	Units
Full-scale voltage level	0.1–1.7	0–1.8	V
Resolution	15	12	bit

Table 4-16: ADC Interface Characteristics (Continued)

	ADC0 / ADC1 Value	ADC2 / ADC3 Value ^a	Units
Sample rate	1.15	20.000–818.330	ksp/s
Voltage error	8 (Typ) 16 (Max)	2 (Typ)	mV

a. ADC2 and ADC3 are only available in Group A variants.

4.18 Digital Audio

The AirPrime WP76XX provides a 4-wire digital audio interface that can be configured as either PCM (Pulse Code Modulation) or I²S (Inter-IC Sound).

Also, when the interface is configured as PCM, the audio output (PCM_OUT) can be redirected to the USB interface using the standard Legato USB Audio Class — for details, refer to http://legato.io/legato-docs/latest/c_audio.html.

Table 4-17 on page 95 describes the audio interface signals.

Note: Audio availability is firmware-dependent.

Table 4-17: PCM / I²S Interface Signals

Pin	Signal name	Direction ^a	Function	If Unused
33	PCM_OUT	Output	PCM Data Out The frame “data out” relies on the selected configuration mode.	Leave open
	I2S_OUT	Output	I2S Data Out The frame “data out” relies on the selected configuration mode.	
34	PCM_IN	Input	PCM Data In The frame “data in” relies on the selected configuration mode.	Leave open
	I2S_IN	Input	I2S Data In The frame “data in” relies on the selected configuration mode.	
35	PCM_SYNC	Input/Output	PCM Sync The frame synchronization signal delivers an 8 kHz frequency pulse that synchronizes the frame data in and the frame data out.	Leave open
	I2S_WS	Output	I2S Word Select The word select clock indicates which channel is currently being transmitted (low cycle indicates left audio channel, high cycle indicates right audio channel).	
36	PCM_CLK	Input/Output	PCM Clock The frame bit clock signal controls data transfer with the audio peripheral.	Leave open
	I2S_CLK	Output	I2S Clock The frame bit clock signal controls data transfer with the audio peripheral.	

- a. Signal direction with respect to the module. Examples: PCM_IN (pin 34) is an input to the module from the host; PCM_OUT (pin 33) is an output from the module to the host.

PCM

Table 4-18 defines the PCM interface configuration.

Table 4-18: PCM Interface Configurations

Element	PCM
Slot configuration	Slot-based
Sync type	Short
Clock (in Master mode)	2.048 MHz
Data formats	16-bit linear, 8-bit A-law, 8-bit mu-law
Mode	Master or Slave

PCM Data Format

The PCM data is 8 kHz and 16 bits with the following PDM (Pulse-density modulation) bit format:

- PCM_DIN — SDDD DDDD DDDD DDVV
- PCM_DOUT — SDDD DDDD DDDD DDVV

Where:

- S — Signed bit
- D — Data
- V — Volume padding

4.18.0.1 PCM Timing

The following table and drawings illustrate PCM signals timing when operating in PCM mode.

Table 4-19: PCM Mode Timing^a

Parameter	Description	Min	Typ	Max	Units
t(sync)	PCM_SYNC cycle time	-	125	-	μs
t(synch)	PCM_SYNC high time	-	488	-	ns
t(syncl)	PCM_SYNC low time	-	124.5	-	μs
t(clk)	PCM_CLK cycle time	-	488	-	ns
t(clkh)	PCM_CLK high time	-	244	-	ns
t(clkl)	PCM_CLK low time	-	244	-	ns
t(susync)	PCM_SYNC setup time high before falling edge of PCM_CLK	-	122	-	ns
t(sudin)	PCM_IN setup time before falling edge of PCM_CLK	60	-	-	ns
t(hdin)	PCM_IN hold time after falling edge of PCM_CLK	10	-	-	ns
t(pdout)	Delay from PCM_CLK rising to PCM_OUT valid	-	-	60	ns
t(zdout)	Delay from PCM_CLK falling to PCM_OUT HIGH-Z	-	160	-	ns

a. Maximum PCM clock rate is 2.048 MHz.

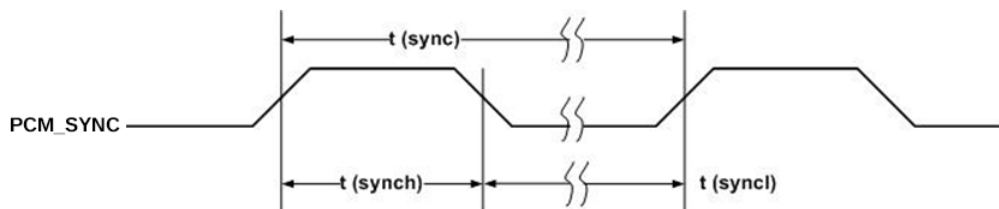


Figure 4-7: PCM_SYNC Timing Diagram (2048 kHz clock)

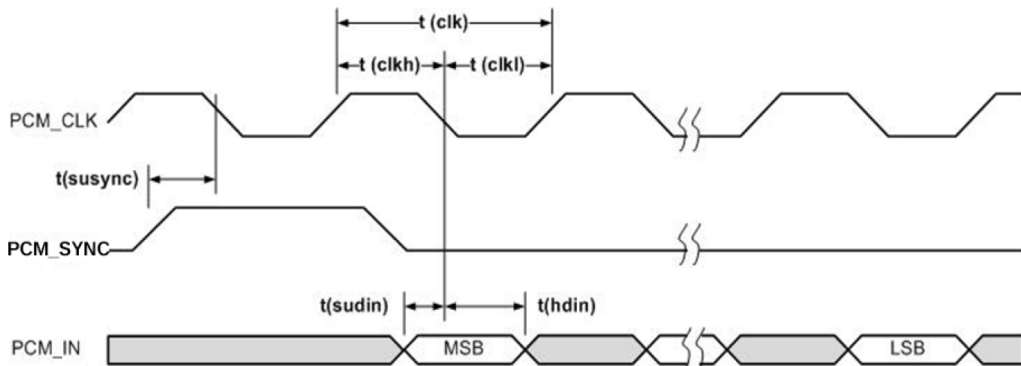


Figure 4-8: PCM Codec to Device Timing Diagram

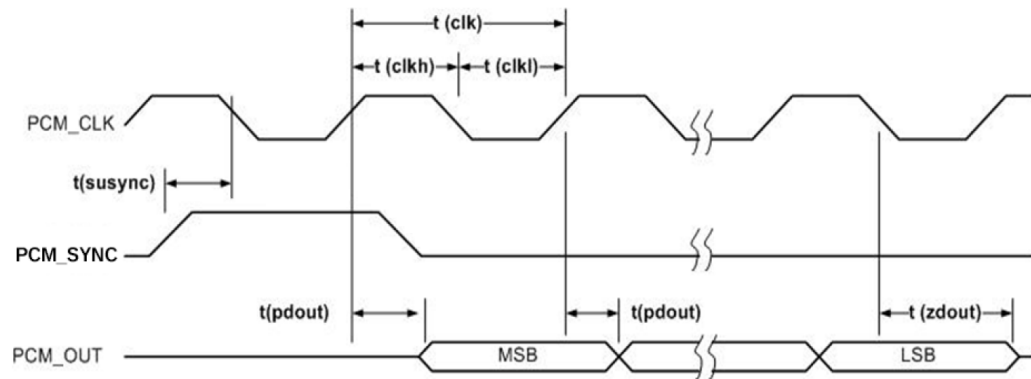


Figure 4-9: Device to PCM Codec Timing Diagram

4.18.1 I²S

The I²S interface can be used to transfer serial digital audio to or from an external stereo DAC/ADC and supports the following features:

- Mode: Master (Slave mode is not supported)
- Sampling rate: 48 kHz
- Bits per frame: 16
- Bit clock: 1536 kHz

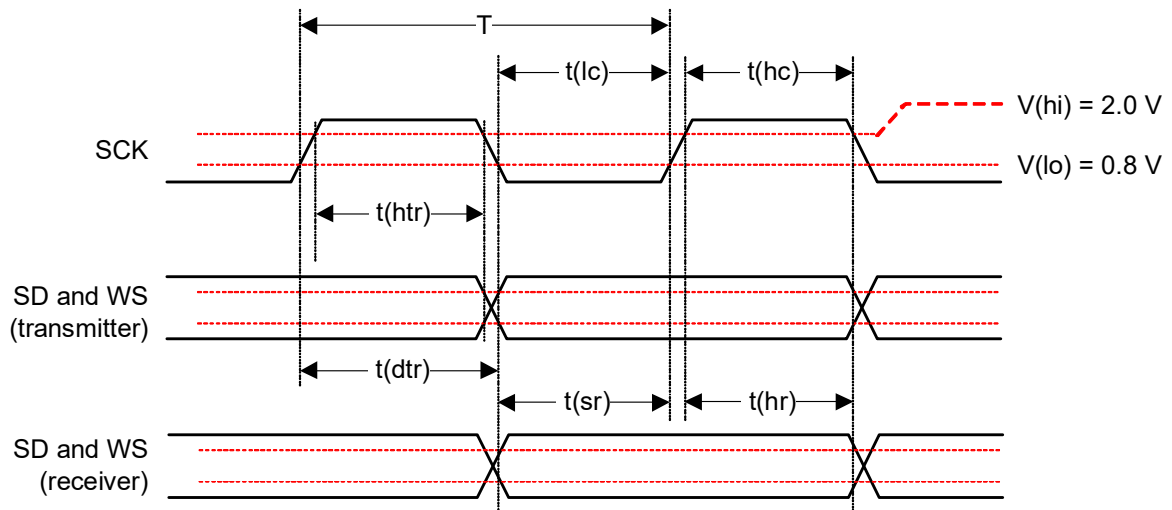


Figure 4-10: I²S Transmitter Timing

Table 4-20: I²S Interface Timing^a

Parameter	Description	Min	Typ	Max	Units
	Frequency	-	-	12.288	MHz
T	Clock period	81.380	-	-	ns
t(hc)	Clock high	0.45 × T	-	0.55 × T	ns

Table 4-20: I²S Interface Timing^a (Continued)

Parameter	Description	Min	Typ	Max	Units
t(lc)	Clock low	0.45×T	-	0.55×T	ns
t(sr)	SD and WS input setup time	16.276	-	-	ns
t(hr)	SD and WS input hold time	0	-	-	ns
t(dtr)	SD and WS output delay	-	-	65.100	ns
t(htr)	SD and WS output hold time	0	-	-	ns

a. Load capacitance is 10–40 pF

4.19 SPI Bus

The AirPrime WP76XX module provides one 4-wire serial peripheral interfaces (SPI1).

The following features are available on the SPI bus:

- Mode: Master (Slave mode is not supported)
- SPI speed from 960 kbps to 25 Mbps in master mode operation
- 4-wire interface
- 4 to 32 bits data length

[Table 4-21](#) on page 99 describes the SPI interface pins.

Table 4-21: SPI Pin Descriptions

Pin	Signal Name	Direction ^a	Description	Reset State	I/O Type
51	SPI1_MRDY	Output	SPI Master Ready	Z	1V8
52	SPI1_MISO	Input	SPI Master Input/Slave Output (output from slave)	Z	
53	SPI1_CLK	Output	SPI serial clock (output from Master)	Z	
54	SPI1_MOSI	Output	SPI Master Output/Slave Input (output from master)	Z	

a. Signal direction with respect to module. Examples: SPI1_MISO (pin 52) is an input too the module from the host; SPI1_CLK (pin 53) is an output from the module to the host.

4.19.1 SPI Configuration

Table 4-22: SPI Configuration

Operation	Max Speed	SPI-Mode	Duplex	4-wire Type
Master	25 Mb/s	0,1,2,3	Full	<ul style="list-style-type: none"> ▪ SCLK (SPI1_CLK) ▪ MOSI (SPI1_MOSI) ▪ MISO (SPI1_MISO) ▪ SS (SPI1_MRDY)

4.19.2 SPI Waveforms

The following figure shows waveforms for SPI transfer using a 4-wire configuration.

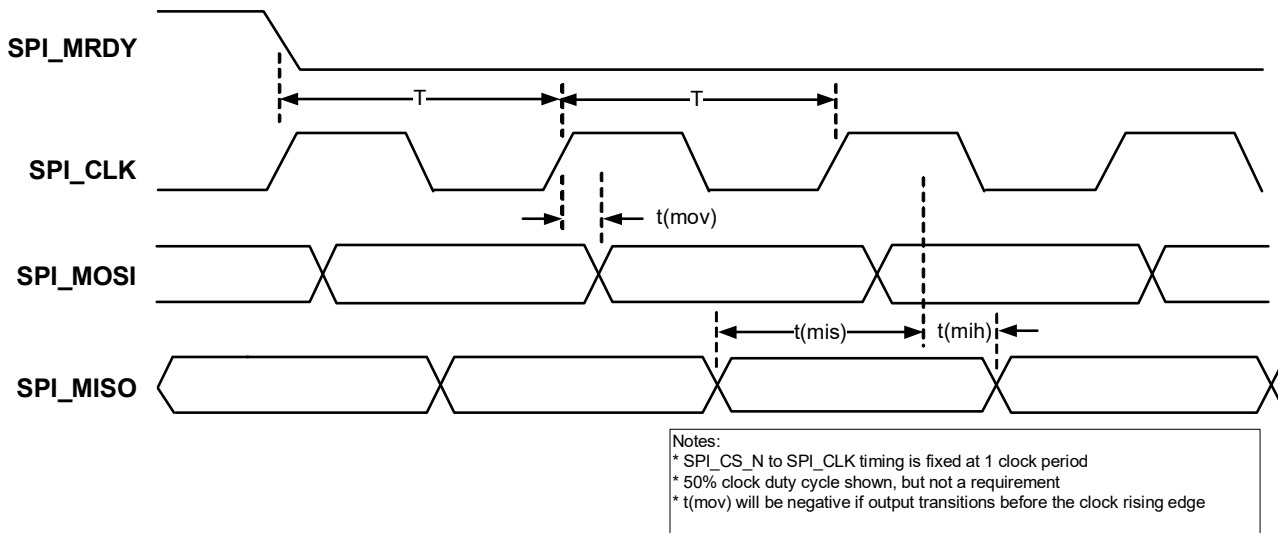


Figure 4-11: 4-Wire Configuration SPI Transfer

Table 4-23: SPI Master Timing Characteristics (@38 MHz)

Parameter		Min	Typ	Max	Unit
SPI clock frequency		-	-	38	MHz
T^a	SPI clock period	20.0	-	-	ns
t(ch)	Clock high	9.0	-	-	ns
t(cl)	Clock low	9.0	-	-	ns
t(mov)	Master output valid	-5.0	-	-5.0	ns
t(mis)	Master input setup	5.0	-	-	ns
t(mih)	Master input hold	1.0	-	-	ns

a. Minimum clock period includes 1% jitter of the maximum frequency

4.19.3 Application

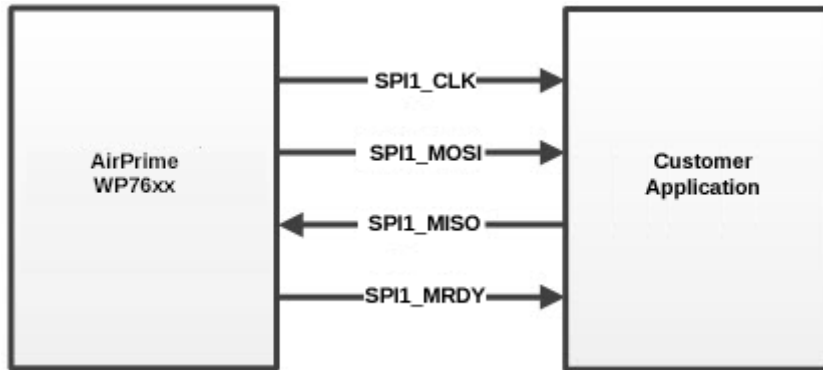


Figure 4-12: Example of 4-wire SPI Bus Application

4.20 HSIC Bus

The AirPrime WP76XX module provides a 2-wire HSIC (High-Speed Inter-Chip) bus.

Important: *If the HSIC bus is not used on the host application, a pull-down resistor (20k–50k) should be added to each HSIC line to disable the interface. (Alternatively, the interface can be disabled using the !CUSTOM AT command with the "HSICENABLE" customization. See [1] AirPrime WP8548/WP75xx/WP76xx/WP77xx AT Command Reference for details.)*

Table 4-24: HSIC Pin Descriptions

Pin	Signal Name ^a	Direction ^a	Description	Reset State	I/O Voltage
14	HSIC_DATA	I/O	HSIC data	Z	1.2V
15	HSIC_STRB	I/O	HSIC strobe signal	Z	

a. From host view

4.20.1 HSIC Waveforms

Refer to [2] Inter-Chip USB Supplement to the USB 2.0 Specification Revision 1.0.

4.20.2 Application

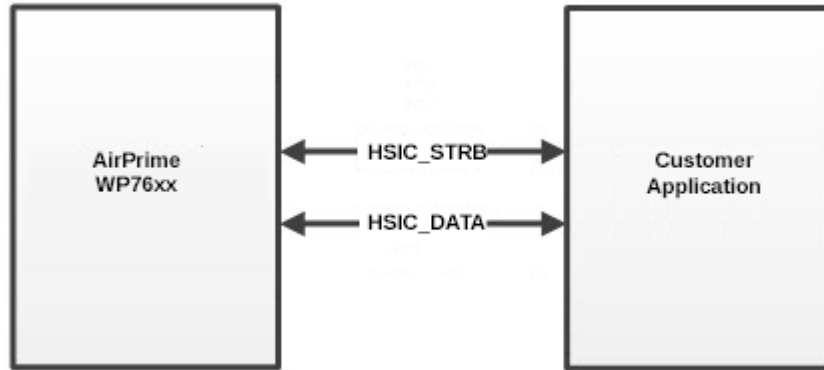


Figure 4-13: Example of 2-wire HSIC Bus Application

Application notes:

- Trace length < 10 cm
- Skew between data and strobe signals < 15 ps
- HSIC_DATA and HSIC_STRB should maintain a 50Ω impedance routing, and isolation between the lines should be maintained

4.21 Clock

The AirPrime WP76XX module supports two digital clock interfaces that are connected directly from the PMIC.

Table 4-25 describes the clock interface pins.

Table 4-25: Clock Interface Pin Descriptions

Pin	Signal name	I/O	I/O type	Description	If Unused
22	SYS_CLK	Output	1.8V	19.2 MHz digital clock output	Leave open
23	SLEEP_CLK	Output	1.8V	32.768 kHz digital clock output	Leave open

4.22 TP1 (Boot Pin)

The TP1 pin (boot pin) can be used for two primary purposes:

- The pin can be used to force the module to enter boot-loader mode on power-up—Connect the pin to a control mechanism (for example, a button, switch, or jumper) on the host platform, and use this mechanism to assert (drive low) the TP1 pin on power-up. The boot loader monitors the TP1 pin and when it detects a low signal, prevents normal power-up and prepares to download firmware via the DM port.
When the module has restarted and entered boot-loader mode, make sure to de-assert the TP1 pin. When the firmware download finishes, the module reboots automatically and the de-asserted pin allows the module to boot normally.
- If not connected to a control mechanism, at minimum the pin should be connected to a test point on the host platform, for use by Semtech in RMA debugging.

Note: Firmware downloads also occur using software tools available on source.sierrawireless.com or over the air using an AirVantage server.

Table 4-26: TP1 Pin Description

Pin	Name	Direction	Function	If Unused
47	TP1	Input	Device recovery (boot load)	Mandatory test point

4.23 Temperature Monitoring

The AirPrime WP76XX provides internal temperature monitoring of the module’s baseband thermistor, as detailed below in [Figure 4-14](#) and [Table 4-27](#).

The temperature state can be queried directly, and unsolicited notifications of temperature state transitions can be received by using:

- **AT!PATEMP**—Display the current temperature state (normal, hi or low warning, hi or low critical).
- **AT+WUSLMSK**—Enable unsolicited notifications for !PATEMP, to be received over the AT port whenever the state changes.

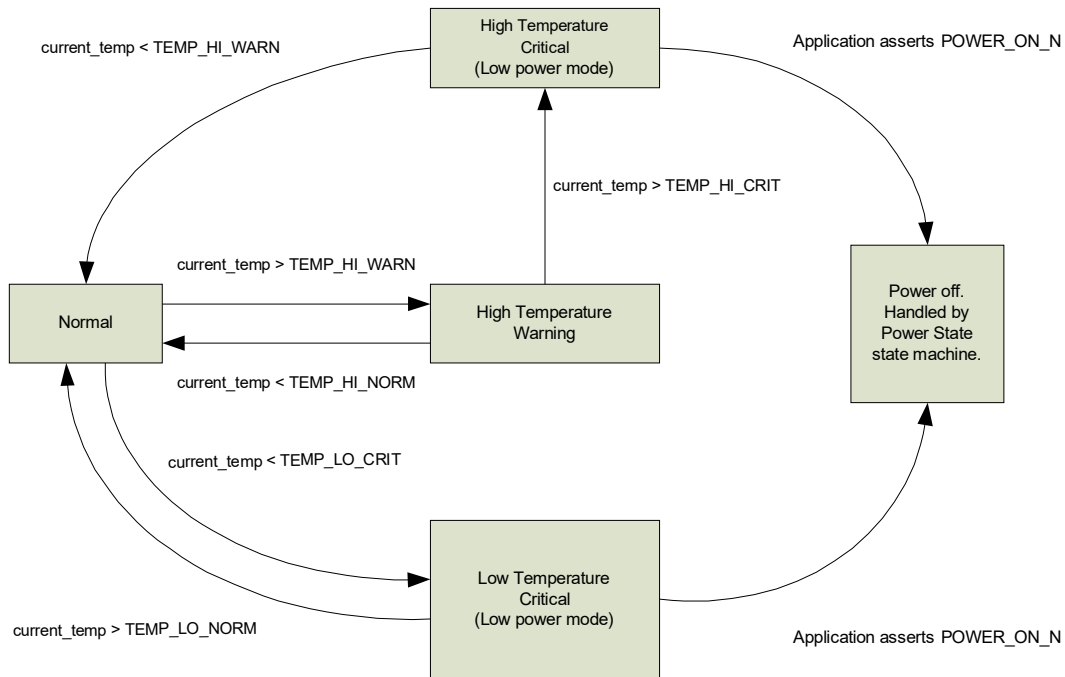


Figure 4-14: Temperature Monitoring State Machine

Table 4-27: Temperature Monitoring States

State	Description	Threshold	Default Temp Value (C) ^a	Functionality
Normal	Baseband thermistor is between	TEMP_HI_NORM	+100	Class A
		TEMP_LO_NORM	-40	Class B
High Temperature Warning	Baseband thermistor has exceeded	TEMP_HI_WARN	+110	Class B
High Temperature Critical	Baseband thermistor has exceeded	TEMP_HI_CRIT	+115	Low Power Mode
Low Temperature Critical	Baseband thermistor has descended past	TEMP_LO_CRIT	-45	Low Power Mode

a. Junction (PA thermistor) temperature

To restore full operation, the baseband thermistor’s temperature reading must be within the normal or high temperature warning state thresholds.

4.24 Test Pins

Semtech requires test points on the customer application for Semtech RMA and debug service.

Table 4-28: Test Pin Descriptions

Pin	Name	Function	If Unused
236	J1	Test point	Mandatory test point
237	J2	Test point	Mandatory test point
238	J3	Test point	Mandatory test point
239	J4	Test point	Mandatory test point
240	J5	Test point	Mandatory test point
241	J6	Test point	Mandatory test point
242	J7	Test point	Mandatory test point
243	J8	Test point	Mandatory test point
244	J9	Test point	Mandatory test point

4.25 Antenna Control

The AirPrime WP76XX provides four output signals that can be used for host designs that incorporate tunable antennas.

Note:

- *Antenna control signals support is optional.*
- *It is the responsibility of developers of host designs to evaluate the performance of tunable antennas that use these signals for neighbor cell measurements, Inter-RAT handovers, etc. Semtech does not guarantee ANT_CNTLx signal timing.*
- *These pins can be configured for use as GPIOs using +WIOCFG.*

Table 4-29: Antenna Control Signals

Pin	Name	Direction ^a	Function	If Unused
153	ANT_CNTL0	Output	Customer-defined external switch control for tunable antennas	Leave open
154	ANT_CNTL1	Output		Leave open
155	ANT_CNTL2	Output		Leave open
156	ANT_CNTL3	Output		Leave open

a. Signal direction with respect to module. Examples: ANT_CNTL0 (pin 153) is an output from the module to the host.

To tune the antenna:

1. Enable band selection, which is required to tune the antennas for specific bands:
 - **ATICUSTOM="BANDSELEN",1**
 (Note: This setting is persistent unless disabled by issuing ATICUSTOM="BANDSELEN",0.)
2. Drive the antenna control signals high or low, as required, for a specific band:
 - **ATIANTSEL=<band>, <gpio1>, <gpio2>, <gpio3>[, <gpio4>]**
 See [1] AirPrime WP8548/WP75xx/WP76xx/WP77xx AT Command Reference for details.
 (Note: <gpio1>–<gpio4> correspond to ANT_CTRL0–ANTCTRL3.)

4.26 Indication Interfaces

The AirPrime WP76XX module provides several indication interfaces that deliver notifications when specific events occur. These interfaces include:

- [Tx Activity Indicator \(TX_ON\)](#) on page 106
- [WWAN_LED_N](#) on page 106
- [WAKE_ON_WWAN](#) on page 107
- [Ring Indicator](#) on page 108
- [SAFE_PWR_REMOVE](#) on page 108
- [UIM1_DET](#) on page 108

4.26.1 Tx Activity Indicator (TX_ON)

The AirPrime WP76XX module provides a digital output signal to indicate the occurrence of Tx activity.

Table 4-30: Tx Activity Indicator States

Pin	Signal name	Direction ^a	I/O type	Module state	Signal State
60	TX_ON	Output	1.8V	During Tx activity	High
				No Tx	Low

a. Signal direction with respect to module—TX_ON (pin 60) is an output from the module to the host.

Table 4-31: Tx Activity Indicator Characteristics

Parameter	2G	3G	LTE
T _{advance}	50 μs	22 ms	10.5 ms
T _{delay}	60 μs	90 μs	4 ms

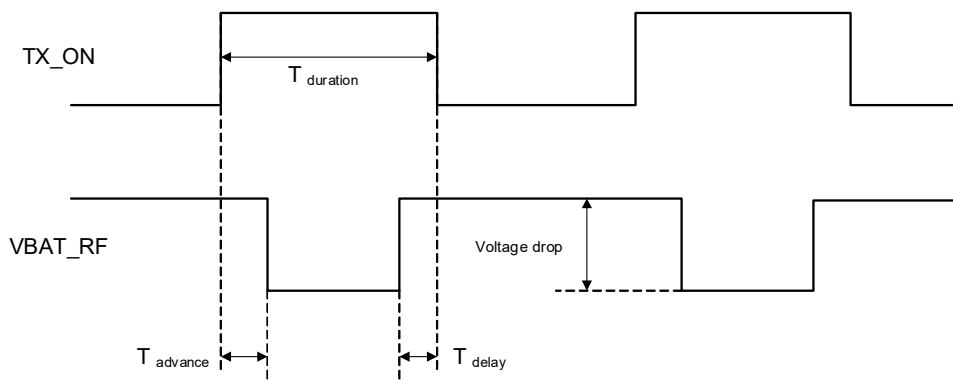


Figure 4-15: TX_ON State During Transmission

4.26.2 WWAN_LED_N

The AirPrime WP76XX provides an LED control output signal pad. This signal is an open drain output.

Table 4-32: LED Interface Pin

Pin	Signal name	Direction ^a	Voltage / Current	Function	If Unused
106	WWAN_LED_N	Output	<ul style="list-style-type: none"> Voltage (max)=VBAT_BB + 0.5 V Maximum current sink capability=40 mA 	LED driver control	Leave open

a. Signal direction with respect to module—WWAN_LED_N (pin 106) is an output from the module to the host.

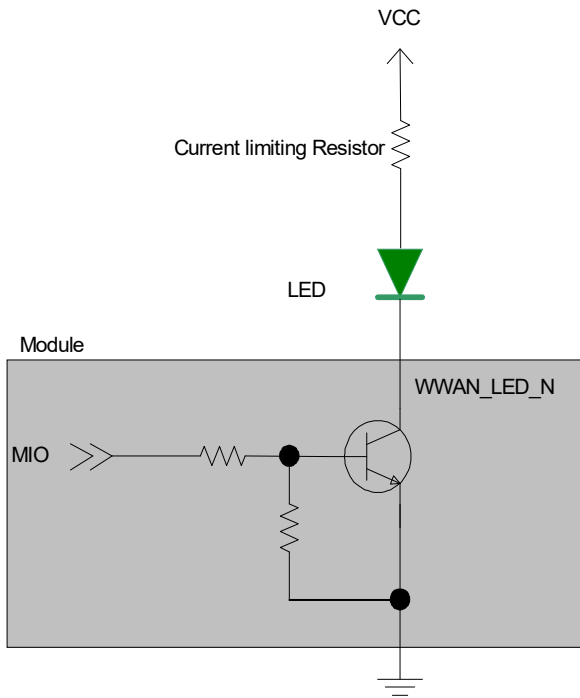


Figure 4-16: LED Reference Circuit

4.26.3 WAKE_ON_WWAN

Note: Host support for WAKE_ON_WWAN signal is optional.

The AirPrime WP76XX drives WAKE_ON_WWAN high to wake the host when specific events which are controlled by the customization setting “**WAKEHOSTEN**” occur. Refer to document [1] AirPrime WP8548/WP75xx/WP76xx/WP77xx AT Command Reference for details.

See [Figure 4-17](#) on page 107 for a recommended implementation.

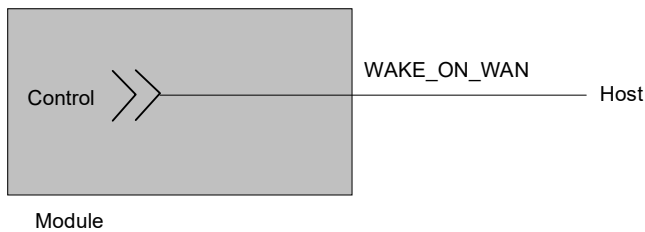


Figure 4-17: Recommended WAKE_ON_WWAN Connection

4.26.4 Ring Indicator

The ring indicator (UART1_RI) may be used to notify an external application of several events such as an incoming call, timer expiration, or incoming SMS. The AirPrime WP76XX pulses the signal high when an event occurs.

Table 4-33: UART1_RI Pin

Pin	Name	Direction ^a	Function	If unused
2	UART1_RI ^b	Output	<ul style="list-style-type: none"> Ring Indicator Signal incoming calls (voice and data), SMS, etc. 	Leave open

- a. Signal direction with respect to the module—UART1_RI (pin 2) is an output from the module to the host.
 b. Do not install an external pull-up on this pin, otherwise the module will not boot.

For additional details, refer to the Legato API documentation at <http://legato.io>.

4.26.5 SAFE_PWR_REMOVE

The SAFE_PWR_REMOVE signal is used by the AirPrime WP76XX to indicate to the host device that VBAT_BB / VBAT_RF can be removed. When the high pulse signal is triggered to low level, it is safe to remove the power supply (after VGPI0 goes low)—see [Figure 4-1](#) on page 82.

4.26.6 UIM1_DET

The UIM Detect signal (UIM1_DET) is used to detect the physical presence of a UIM card in the UIM holder. For details, refer to [UIM Interface](#) on page 85.

4.26.7 DR_SYNC

The AirPrime WP76XX provides DR_SYNC, an output used for GPS dead reckoning synchronization.

The module pulses the DR_SYNC signal once every integer GPS second. While position fixes are occurring, the DR_SYNC pulse is aligned precisely with the GPS time. When a position fix cannot be made (for example, when a vehicle has entered a tunnel), the module continues to pulse the DR_SYNC signal every second while the level of uncertainty of the GPS time is low. When the uncertainty level is high, the module stops pulsing the signal.

Table 4-34: DR_SYNC Pin Details

Pin	Signal name	Direction ^a	Function	If Unused
42	DR_SYNC	Output	GPS dead reckoning sync signal	Leave open

- a. Signal direction with respect to the module—DR_SYNC (pin 42) is an output from the module to the host.

4.27 W_DISABLE_N — Wireless Disable

Note: Host support for wireless disable signals is optional.

The host device uses W_DISABLE_N (pin 151) to enable / disable the WWAN or radio modem. When disabled, the modem cannot transmit or receive information.

Letting this signal float high allows the module to operate normally. The pin has an internal pull-up resistor. See [Figure 4-18](#) for a recommended implementation.

When integrating with your host device, keep the following in mind:

- The signal is an input to the module and should be driven LOW only for its active state (controlling the power state); otherwise it should be floating or (High impedance). It should never be driven to a logic high level. The module has an internal pull-up resistor to an internal 1.8V rail, so if the signal is floating or (high impedance), then the radio is on.
- If the host never needs to assert this power state control to the module, leave this signal unconnected from the host interface.

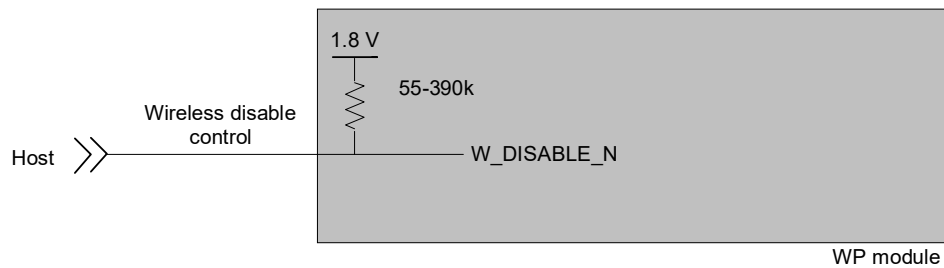


Figure 4-18: Recommended Wireless Disable Connection

5: Routing Constraints and Recommendations

This section describes general routing constraints and recommendations for the AirPrime WP76XX module.

Note: This is a non-exhaustive list of suggested design guidelines. The developer is responsible for deciding whether to implement these guidelines.

5.1 General Rules and Recommendations

Clock and other high-frequency digital signals (e.g. serial buses) should be routed as far as possible from the module's analog signals.

If the application design makes it possible, all analog signals should be separated from digital signals by a ground trace on the PCB.

Tip: Avoid routing any signals under the module on the application board.

5.2 Power Supply

When designing the power supply, make sure that VBAT_BB/VBAT_RF meet the requirements listed in [Power Supply Ratings](#) on page 31.

Careful attention should be paid to the following:

- Power supply quality — PFM, or PSM systems should be avoided; Low ripple, linear regulation or PWM converters are preferred for low noise.
- Capacity to deliver high current peaks in a short time (for pulsed radio emission)
- VBAT_BB/VBAT_RF must support peak currents with an acceptable voltage drop that guarantees the minimum required VBAT_BB/VBAT_RF value.
- VBAT_BB/VBAT_RF signal pads must never exceed the maximum required VBAT_BB/VBAT_RF value, otherwise the module's power amplifier and GPS chipset may be severely damaged.
- A weakly-designed (not robust) power supply could affect EMC performance, the emission spectrum, and the phase error and frequency error.

5.3 Antenna

Semtech strongly recommends working with an antenna manufacturer either to develop an antenna adapted to the application, or to adapt an existing solution to the application.

For information on routing constraints for the RF circuit, see [RF Circuit](#) on page 114.

5.3.1 OTA Considerations when Developing Products that Include an Integrated Antenna

Developing a product with an integrated antenna is challenging considering RF design and performances; difficulty increases with the level of integration. Smaller product size implies:

- The smaller the antenna, the more challenging to reach the expected antenna efficiency.
- Large RF TX signal level radiated by the antenna can be captured by nonlinear devices and create, by rectification, a high level of unwanted harmonics.
- As much as the distance between the antenna and electronic devices (including the module and other application related hardware) decreases, coupling to clocks and DC/DC switchers harmonics and wide band noise sources generated by high speed digital signals increases. Such a coupling may create receiver desensitization from the resulting noise generated at the receiver frequency bands.

It is essential to take into account appropriate design rules when developing new products and to evaluate OTA performances at an early stage of product integration:

- TRP (Total Radiated Power): To verify the antenna efficiency at TX frequency bands and compliance to spurious emission requirements.
- TIS (Total Isotropic Sensitivity): To verify the antenna efficiency at RX frequency bands and evaluate the presence of noise generated into supported frequency bands subject to cause receiver desensitization.

5.4 PCB Layout Recommendations

5.4.1 General Design Rules

- Application board should be designed in such a way that provides a plain GND connection on the whole surface located under the module area. A matrix of high density vias should be implemented to connect the top layer (in contact to the module LGA ground pads) to other GND layers. Such implementation aims to reduce noise interference, spurious radiation and improve heat dissipation spreading heat through the PCB surface and layers.
- To reduce coupling between antenna and other signals and improve EMC, the top and bottom layers of the PCB should be covered by solid GND plan as much as possible.
- Good PCB grounding is essential; use ground planes that are as wide as possible and link the different planes from each layers using regularly spaced via holes. Particularly, via should be present all around the PCB edge to block any unwanted EMI emitted from the power tracks.
- Sensitive signals should be shielded by routing them into inner layers (to prevent them from radiating) and sensitive components can be shielded. The top and bottom ground planes connected together with vias ensures all sensitive traces are shielded well. This significantly reduces coupling between antenna and other signals and improves EMI and EMC performances.
- When it is not possible to route a signal trace into inner layers, top and bottom layers can be used for short distance connections (i.e. connections between adjacent pads).
- It is good practice during the design phase to anticipate and reserve area for shield cans.
- The module's power supply needs decoupling capacitors to filter out noise to prevent it from reaching the module. It could cause instabilities in the RF output in the transmitter, resulting in undesired interference and spurious radiations. In the receiver, it increases packet error and reduces sensitivity.
- Place a decoupling capacitor (10–33pF is recommended) as close to the power supply pin of the module as possible.
- Use as many vias as possible to build a ground fence around the RF stripline and microstrip line to isolate it from other signals.
- In some specific cases, like impedance controlled lines and RF connection pads and antenna pads, sufficient keep out distance between RF signals and GND should be implemented to prevent impedance mismatch from parasitic capacitance load.

5.4.2 Specific Design Rules to Support TRP Performances

- Prevent neighboring components from being interfered by TX radiated RF energy especially at GSM transmit frequencies to prevent them from generating harmonics through non-linear behavior such as saturation or

rectification. The mandatory maximum radiated harmonics level for R&TTE/PTCRB certification is below -30dBm and can be very easily failed with inappropriate design.

- When possible, add 10–33pF in parallel of each fast rectifier diode to prevent generating harmonics (due to the TX signal detection and especially when GSM bands are supported).
- With an antenna located close to circuitry using active devices, shielding may be needed to reach enough isolation.

5.4.3 Specific Design Rules to Support TIS Performance

- High speed digital signal (such as DC/DC converters, system clock, CPU and Memory bus, USB and other high speed interfaces) should be isolated and located as far as possible from RF signals and antenna.
- Good practice for interferences prevention is to add decoupling capacitors (10–33pF recommended) every 10mm on all top and bottom power lines longer than 10mm.
- With an antenna located close to circuitry using active devices or noisy signals, shielding may be needed to reach enough isolation.

5.5 PCB Specifications for the Application Board

Sensitive signals (such as audio, UIM, and clocks) should be protected by ground planes/fills. Routing sensitive signals close to noisy signals could result in noise being coupled.

5.6 Recommended PCB Land Pattern

Refer to the AirPrime WP76XX Customer Process Guidelines document, available at <http://source.sierrawireless.com>.

5.7 Routing Constraints

5.7.1 Power Supply

If the following design recommendations are not followed, phase error (peak) and power loss could occur.

Note: The recommended power supply capacity (Table 3-3 on page 32) is greater than the maximum peak current to provide an operating margin.

- Since the maximum peak current can reach 2.5 A, Semtech strongly recommends having a large width for the layout of the power supply signal (to avoid voltage loss between the external power supply and VBAT_BB/ VBAT_RF).

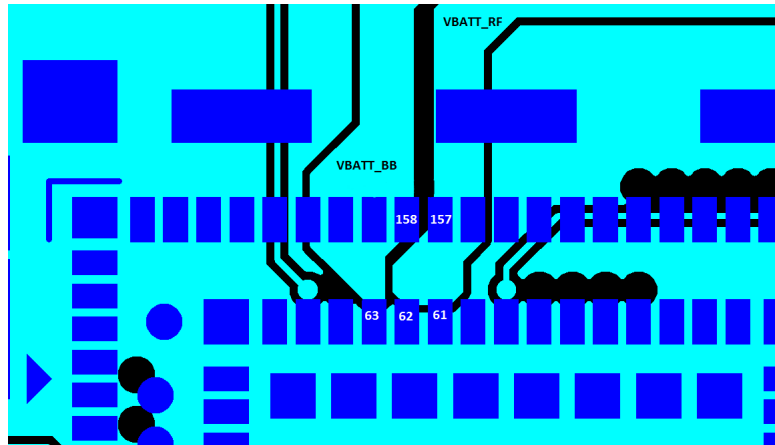


Figure 5-1: Power Supply Routing Example

Note:

- Figure 5-1 shows separate traces for VBAT_BB and VBAT_RF. If VBAT_BB and VBAT_RF share a single power supply, these traces should be connected.
- For optimal decoupling, place the capacitors on the underside of the board, directly under the pins.
- Input capacitors ($2 \times 47 \mu\text{F}$) are required close to the module.
- Attention should be paid to the ground trace or the ground plane on the application board for the power supply that supplies the module. The ground trace or ground plane, as well as the VBAT trace, must be able to support current peaks.
- If the ground trace between the module and the power supply is a copper plane, make sure it is a solid plane.
- Design routing to make sure total line impedance does not exceed $10 \text{ m}\Omega$ @ 217 Hz.

5.7.1.1 Ground Plane Connection

The AirPrime WP76XX module requires a solid, central ground plane (with solder mask defined pads) located directly under the module. This will:

- Ensure high current signal returns
- Provide heat dissipation under higher operating temperatures

The ground plane should be connected (with vias) to the reference ground layer of the application board.

Do not use a separate GND for the antennas. Connections to GND from the module should be flooded plane using thermal reliefs to ensure reliable solder joints.

5.7.2 UIM Interface

- Tracks between the AirPrime WP76XX and the UIM socket should be as short as possible. Maximum recommended length is 10 cm.
- ESD protection is mandatory on the UIM lines and must be placed near the UIM holder, unless:
 - An eSIM is being used, or
 - There is no physical access to the UIM.

- The decoupling capacitor(s) should be placed as close as possible to the UIM card connector for the UIM1_VCC signal.

5.7.3 RF Circuit

The RF signal must be routed on the application board using tracks with a 50 Ω characteristic impedance.

The characteristic impedance depends on the dielectric, the track width and the ground plane spacing.

It is recommended to use stripline design if the RF path is fairly long (more than 3 cm), since microstrip design is not shielded. Consequently, the RF (transmit) signal may interfere with neighboring electronic circuits. In the same way, the neighboring electronics (micro-controllers, etc.) may interfere with the RF (receive) signal and degrade the reception performance.

The RF trace on the development board is routed from the AirPrime WP76XX antenna port to the RF connector (IPEX MHF-4). The RF trace is designed as a 50Ω coplanar stripline and its length is 20.7 mm.

The following drawings show the location of the AirPrime WP76XX on the development board, the routing cross-section, and the top view of the RF trace on the development board.

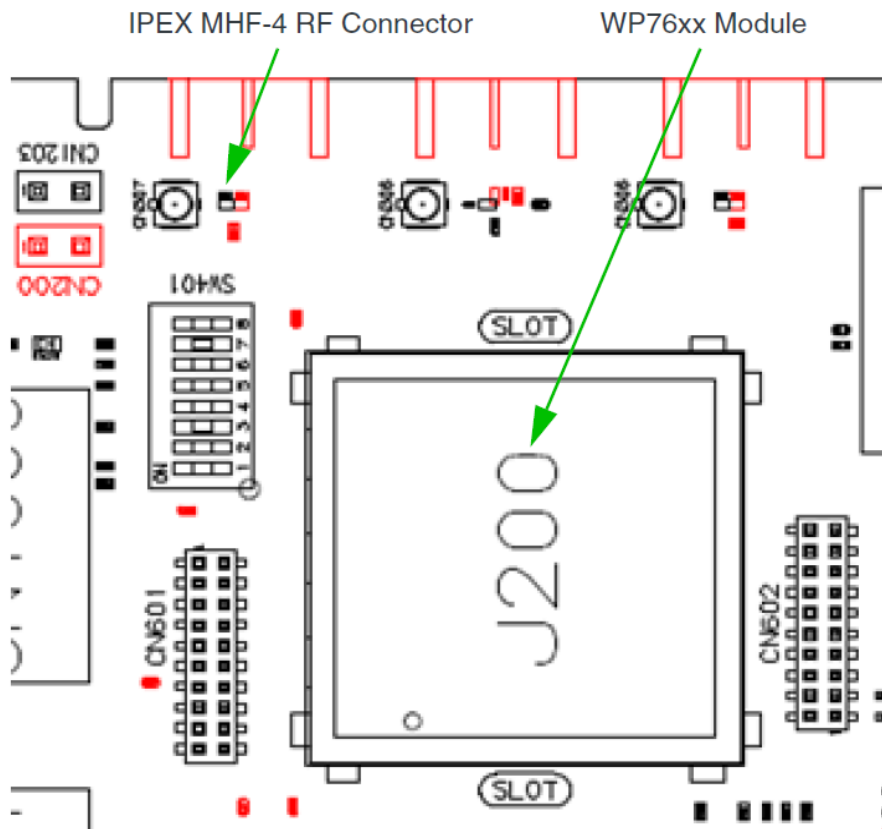


Figure 5-2: Module Location on Development Board

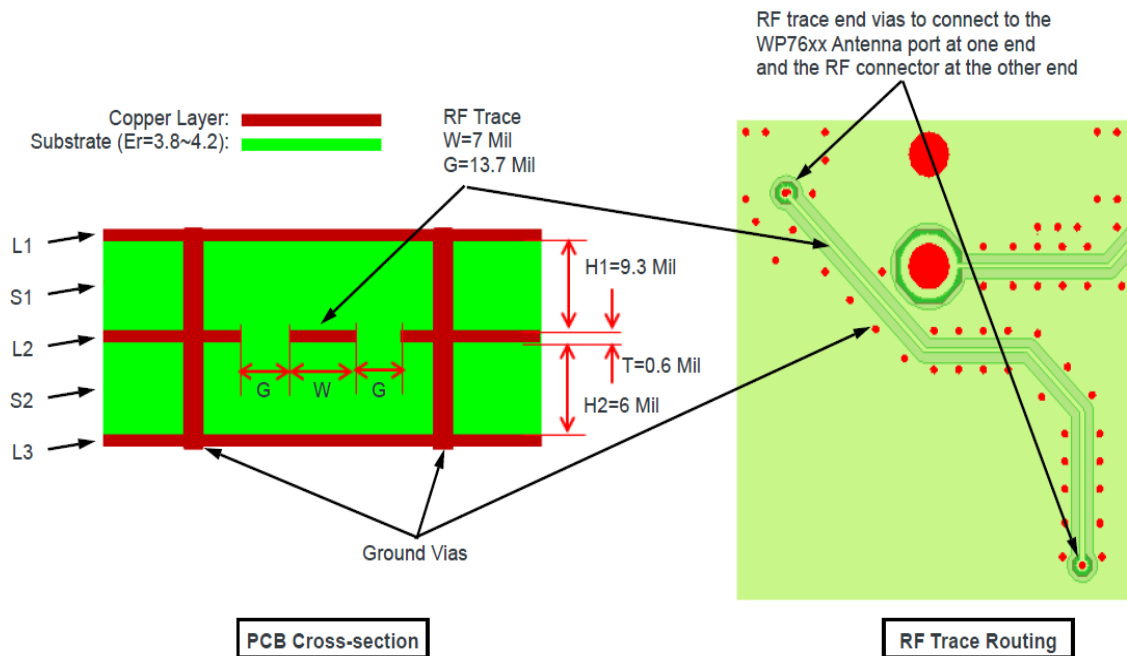


Figure 5-3: Development Board RF Trace Design

5.7.4 USB Interface

When the USB interface is externally accessible, ESD protection is required on the USB_VBUS, USB_D+, and USB_D- signals.

High-speed USB signals (USB_D+ / USB_D-) are a differential pair and must be routed with 90Ω differential impedance.

5.7.5 HSIC Routing Recommendations

HSIC signals (HSIC_STRB / HSIC_DATA) are single-ended and must be routed with the following considerations / constraints:

- 50Ω single-ended $\pm 10\%$ trace impedance
- Isolation between the lines should be maintained
- Trace lengths < 10 cm

5.8 Thermal Considerations

When transmitting, the AirPrime WP76XX can generate significant amounts of heat (due to the internal Power Amplifier) that must be dissipated in the host device for safety and performance reasons.

The amount of thermal dissipation required depends on the following factors:

- Supply voltage — Maximum power dissipation for these modules can be up to 3 W at voltage supply limits.
- Usage — Typical power dissipation values depend on the location within the host, amount of data transferred, etc.

To enhance heat dissipation:

- Maximize airflow over / around the module
- Locate the module away from other components that generate heat
- Ensure the module is connected to a solid ground plane

5.9 EMC and ESD Recommendations

EMC tests must be performed on the application as soon as possible to detect any potential problems.

When designing, special attention should be paid to:

- Possible spurious emissions radiated by the application to the RF receiver in the receiver band
- ESD protection — Typically, ESD protection is mandatory for externally accessible signals, including:
 - VBAT_RF/VBAT_BB
 - UIM (if accessible from outside)
 - Serial link
 - USB
 - Antennas
- Length of the UIM interface lines (preferably <10 cm)
- Length of the HSIC interface lines (<10 cm, as required by the HSIC specification)
- EMC protection on audio input/output (filters against 900 MHz emissions)
- Ground plane: Semtech recommends a common ground plane for analog/digital/RF grounds

Note: The AirPrime WP76XX does not include any protection against over-voltage.

The host device must provide adequate ESD protection on digital circuits and antenna ports as detailed in the following table.

Note: The level of protection required depends on your application.

Table 5-1: ESD Specifications^a

Category	Connection	Specification
Operational	<ul style="list-style-type: none"> ▪ RF ports ▪ UIM connector ▪ USB connector ▪ UART connector 	IEC-61000-4-2 - Level (Electrostatic Discharge Immunity Test) <ul style="list-style-type: none"> ▪ ± 6kV Contact ▪ ± 8kV Air
Non-operational	Host connector interface	Unless otherwise specified: <ul style="list-style-type: none"> ▪ JESD22-A114 ± 1kV Human Body Model ▪ JESD22-A115 ± 100V Machine Model ▪ JESD22-C101C ± 500V Charged Device Model

a. ESD protection is highly recommended at the point where the UIM contacts are exposed, and for any other signals that would be subjected to ESD by the user.

5.10 Mechanical Integration

Attention should be paid to:

- Antenna cable integration (bending, length, position, etc)
- Pads of the AirPrime WP76XX to be soldered to the ground plane
- Ensuring proper board layout
- Providing sufficient space around the module for heat dissipation

5.11 Signal Reference Schematics

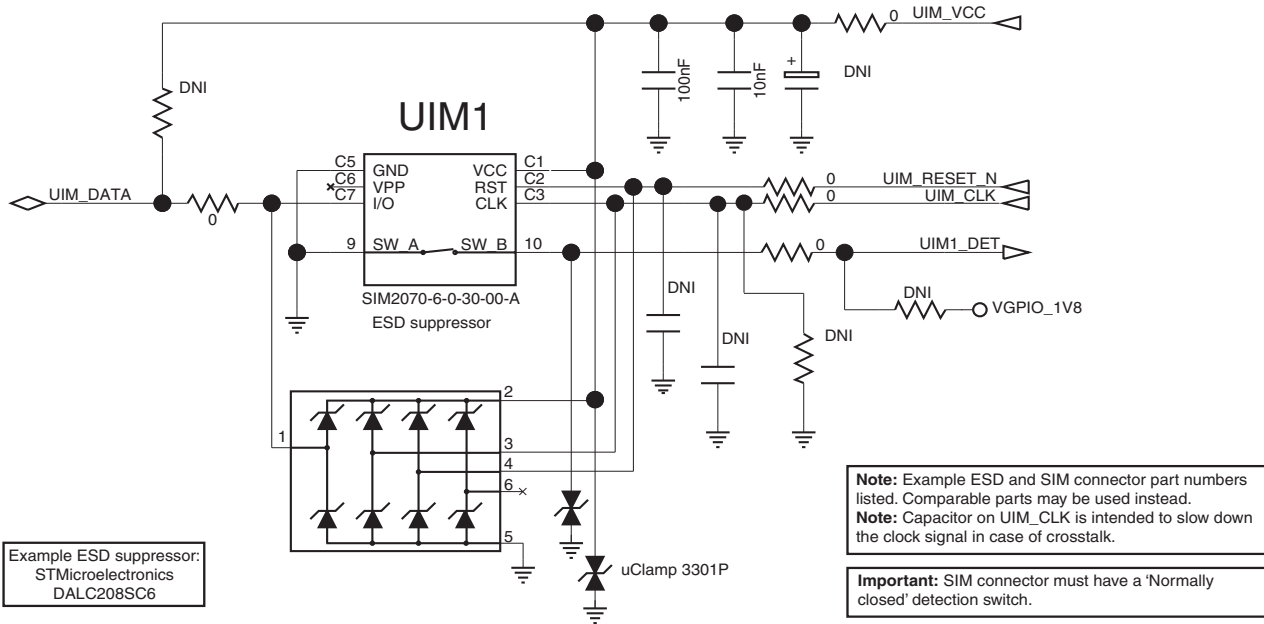


Figure 5-4: UIM Interface

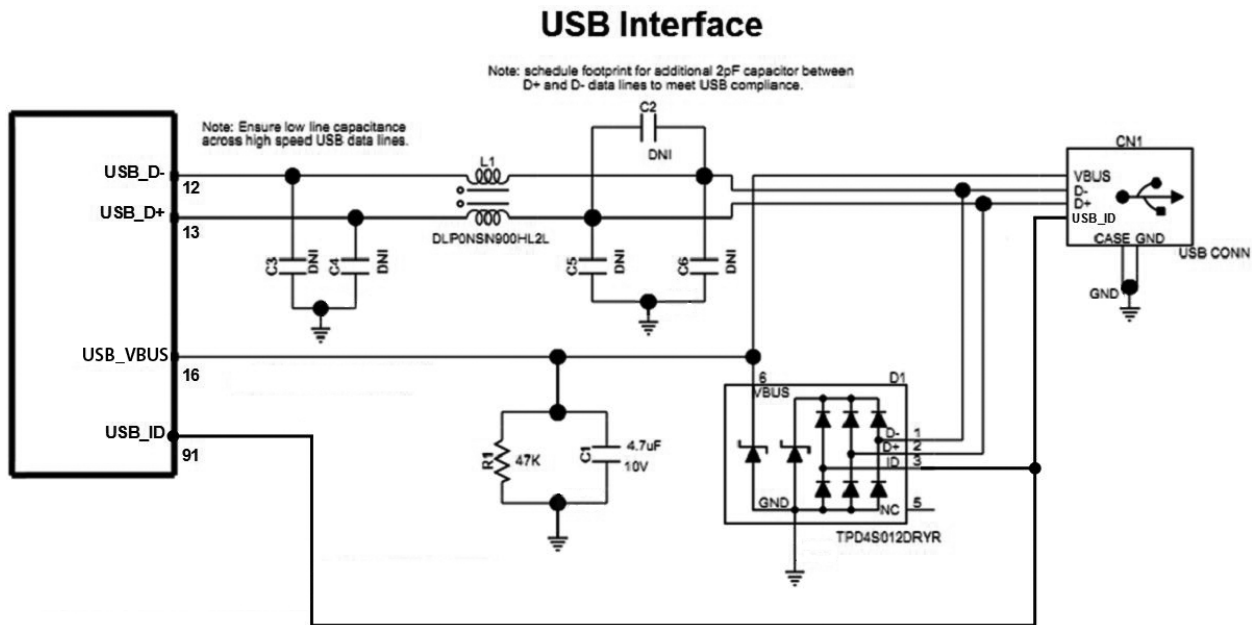


Figure 5-5: USB Interface

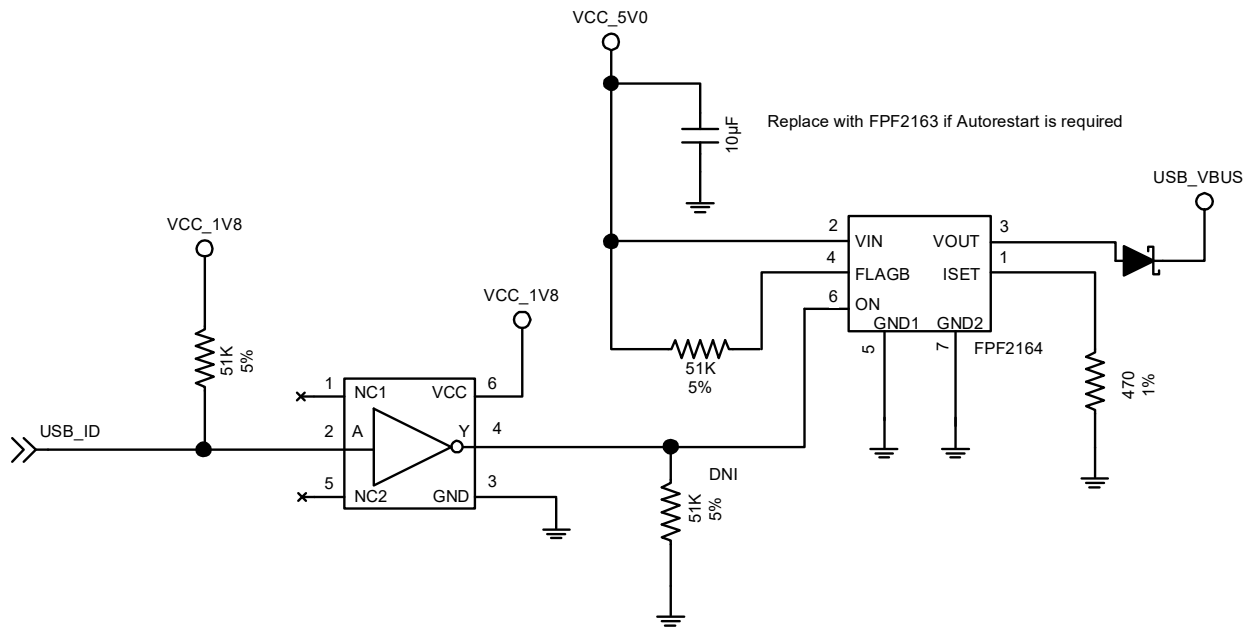


Figure 5-6: USB OTG Interface

6: Software and Tools

6.1 Support Tools

The AirPrime WP76XX is compatible with Semtech's SwiLogPlus trace tool that allows users to send error logs to Semtech.

6.2 SED (Smart Error Detection)

The AirPrime WP76XX uses a form of SED to track premature module resets. In such cases, the module automatically forces a pause in boot-and-hold mode at power-on to accept an expected firmware download to resolve the problem.

1. Module tracks consecutive resets within 30 seconds of power-on.
2. After a sixth consecutive reset, the module waits in boot-and-hold mode (up to 30 seconds) for a firmware download to resolve the power-cycle problem.

A RAM dump tool that can be used to help isolate the cause of premature resets is available from Semtech. Contact your Semtech account representative for assistance.

6.3 Firmware Upgrade

Firmware upgrades are downloaded to the embedded module over the USB interface or over the air via Semtech' AVMS (AirVantage Management System). Contact your Semtech account representative for assistance.

6.4 Operating System Upgrade

The AirPrime WP76XX module's operating system is stored in flash memory and can be easily upgraded.

Tip: *To follow regular changes in the 3GPP standard and to offer a state-of-the-art operating system, Semtech recommends that the application designed around an embedded module (or embedded module based product) should allow easy operating system upgrades on the embedded module via the recommended firmware download protocol. Therefore, the application shall either allow a direct access to the embedded module USB interface through an external connector or implement any mechanism allowing the embedded module operating system to be downloaded.*

6.5 Product Marking

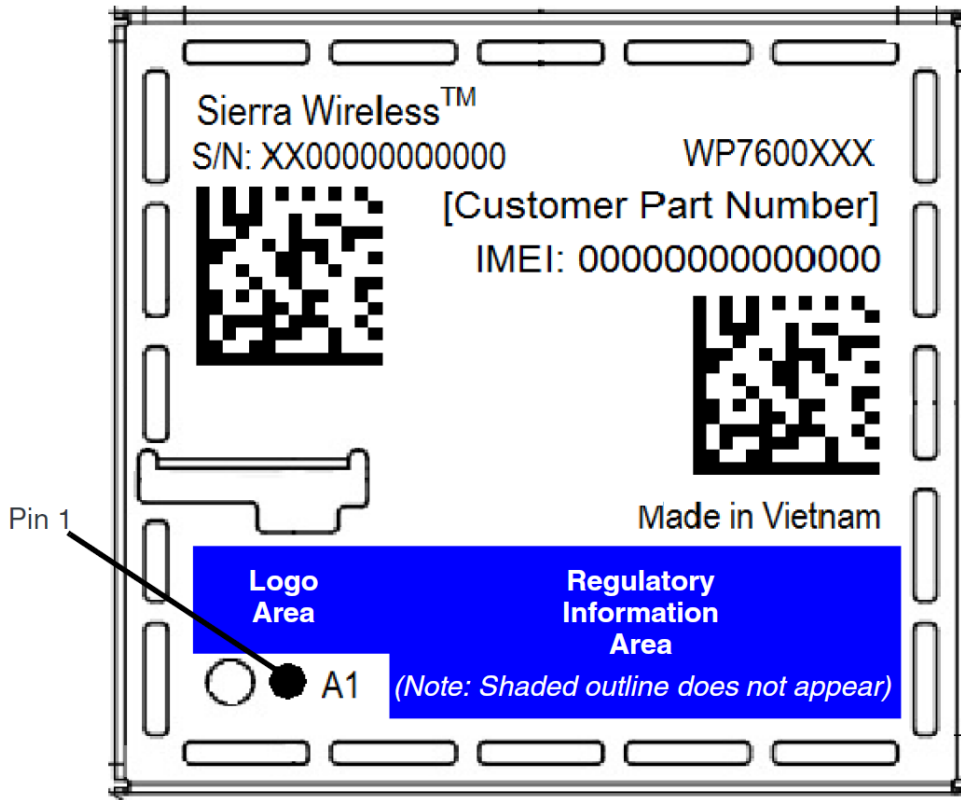


Figure 6-1: Unit Product Marking—Laser-etched, Typical Representation

Note: The figure above is not to scale. Contents will vary by SKU.

The AirPrime WP76XX product marking is laser-etched and may contain:

- Product identification (Model name, serial number)
- IMEI or MEID number and barcode
- Fabrication country
- Required regulatory markings (CE logo, Japan approval mark, FCC ID, IC certification number, etc., as appropriate)
- Pin 1 indicator

Note: The AirPrime WP76XX supports OEM partner specific product marking requirements.

7: Debug and Assembly Considerations

7.1 Testing Assistance Provided by Semtech

Semtech offers optional professional services based assistance to OEMs with regulatory approvals.

7.1.1 Integration Requirements

When integrating the AirPrime WP76XX module, the following items must be addressed:

- Mounting — Effect on temperature, shock, and vibration performance
- Power supply — Impact on battery drain and possible RF interference
- Antenna location and type — Impact on RF performance
- Regulatory approvals — As described in [Legal Information](#) on page 129
- Service provisioning — Manufacturing process

Semtech provides guidelines for successful AirPrime WP76XX module integration with the document suite and offers integration support services as necessary.

7.2 IOT/Operator

Interoperability and Operator/Carrier testing of the finished system is the responsibility of the OEM. The test process will be determined with the chosen network operator(s) and will be dependent upon your business relationship with them, as well as the product's application and sales channel strategy.

Semtech offers assistance to OEMs with the testing process, if required.

7.3 Module Testing Recommendations

When testing your integration design:

- Test to your worst case operating environment conditions (temperature and voltage)
- Test using worst case operation (transmitter on 100% duty cycle, maximum power)
- Monitor the module's junction temperature using AT!PATEMP. This command polls a thermistor located near the module's power amplifier (typically the hottest spot on the module).

Note: Make sure that your system design provides sufficient cooling for the integrated module. The RF shield temperature should not be exposed to an ambient temperature greater than 85 °C to prevent damage to the module's components.

7.4 Serial Link Access

Direct access to the UART1 / UART2 serial link is very useful for:

- Testability operations
- Accessing the module's Linux console for debugging

Refer to the following figure for a level shifter implementation that allows UART1 serial link access. (A UART2 level shifter would use the corresponding UART2 pins — UART2_TX (pin 96), UART2_RX (pin 97), UART2_RTS (pin 98), UART2_CTS (pin 99).)

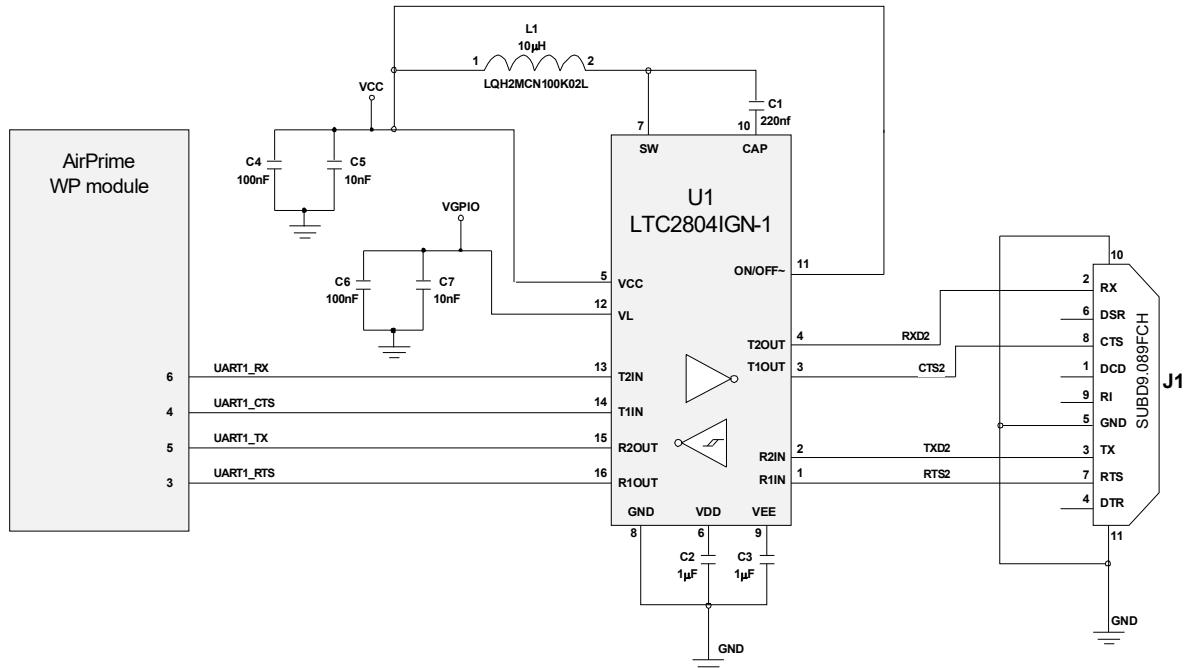


Figure 7-1: Level Shifter Implementation for UART1 Serial Link Access

7.5 RF Output Accessibility

During the integration phase of the AirPrime WP76XX, it can be helpful to connect the module to a simulator to check critical RF TX parameters and power behavior for supported RATs.

Although the AirPrime WP76XX module has been certified, some parameters may have degraded if some basic precautions have not been followed (poor power supply, for example). This may not affect the functionality of the product, but the product may not comply with 3GPP specifications.

The following TX parameters can be checked using a Radio Communication tester:

- Phase & Frequency Error
- Output Power and Burst Time
- Output Spectrum (Modulation and Switching)

The following are available typical Radio Communication testers:

- Rohde & Schwarz: CMU200, CMW500
- Keysight (formerly Agilent): 8960
- Anritsu: MD8475

Because of the high prices associated with Radio Communication testers and the necessary RF know-how to perform simulations, customers can check their applications in the Semtech laboratories. Contact the Semtech support team for more information.

8: Reliability Specification

AirPrime WP76XX modules are tested against the Semtech Industrial Reliability Specification defined below.

8.1 Reliability Compliance

AirPrime WP76XX modules connected on a reliability test board are compliant with the requirements in [Table 8-1](#).

Table 8-1: Standards Conformity


Abbreviation	Definition
IEC	International Electrotechnical Commission
ISO	International Organization for Standardization

8.2 Reliability Prediction Model

8.2.1 Life Stress Test

The following tests the AirPrime WP76XX module's product performance.


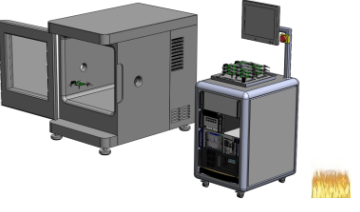
Table 8-2: Life Stress Test

Designation	Condition
Performance Test PT3T & PTRT 	Standard: N/A
	Special conditions: <ul style="list-style-type: none"> ▪ Temperature: <ul style="list-style-type: none"> • Class A: -30°C to +70°C • Class B: -40°C to +85°C • Rate of temperature change: $3 \pm 0.6^\circ\text{C}/\text{min}$ ▪ Recovery time: 3 hours
	Operating conditions: Powered
	Duration: 14 days

8.2.2 Environmental Resistance Stress Tests

The following tests the AirPrime WP76XX module's resistance to extreme temperature.

Table 8-3: Environmental Resistance Stress Tests

Designation	Condition
Cold Test Active COTA 	Standard: IEC 680068-2-1, Test ad
	Special conditions: <ul style="list-style-type: none"> ▪ Temperature: -40°C ▪ Temperature variation: 1°C/min
	Operating conditions: Powered ON with a power cycle of 1 minute ON and 2 minutes OFF
	Duration: 3 days
Resistance to Heat Test RH 	Standard: IEC 680068-2-2, Test Bb
	Special conditions: <ul style="list-style-type: none"> ▪ Temperature: +85°C ▪ Temperature variation: 1°C/min
	Operating conditions: Powered ON with a power cycle of 15 minutes ON and 15 minutes OFF
	Duration: 50 days

8.2.3 Corrosive Resistance Stress Tests

The following tests the AirPrime WP76XX module's resistance to corrosive atmosphere.

Table 8-4: Corrosive Resistance Stress Tests

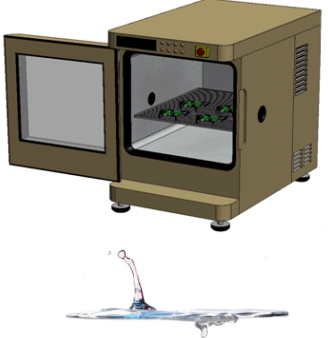

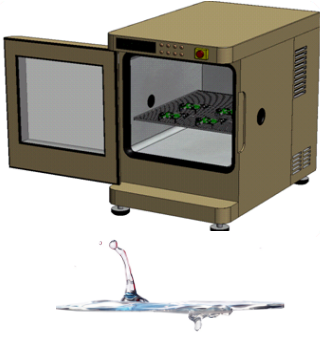
Designation	Condition
Humidity Test HUT 	Standard: IEC 60068-2-3, Test Ca
	Special conditions: <ul style="list-style-type: none"> ▪ Temperature: +65°C ▪ RH: 95% ▪ Temperature variation: 3 ± 0.6°C/min
	Operating conditions: Powered ON with a power cycle of 15 minutes ON and 15 minutes OFF
	Duration: 10 days

Table 8-4: Corrosive Resistance Stress Tests (Continued)

Designation	Condition
Component Solder Wettability CSW 	Standard: JESD22-B102, Method 1/Condition C, Solderability Test Method
	Special conditions: <ul style="list-style-type: none"> ▪ Test method: Dip and Look Test with Steam preconditioning 8 h ± 15 min. Dip for 5 +0/-0.5 seconds
	Operating conditions: Unpowered
	Duration: 1 day
Moist Heat Cyclic Test MHCT 	Standard: IEC 60068-2-30, Test Db
	Special conditions: <ul style="list-style-type: none"> ▪ Upper temperature: +40 ± 2 °C ▪ Lower temperature: +23 ± 5 °C ▪ RH: <ul style="list-style-type: none"> • At upper temperature: 93% • At lower temperature: 95% ▪ Number of cycles: 21 (1 cycle/24 hours) ▪ Temperature variation: 3 ± 0.6 °C/min
	Operating conditions: Powered ON for 15 minutes during each 3 hours ramp up and 3 hours ramp down (in middle) for every cycle
	Duration: 21 days

8.2.4 Thermal Resistance Cycle Stress Tests

The following tests the AirPrime WP76XX module's resistance to extreme temperature cycling.

Table 8-5: Thermal Resistance Cycle Stress Tests

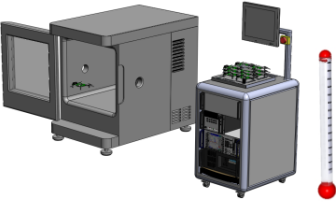
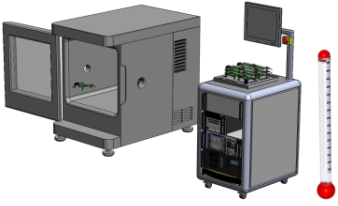
Designation	Condition
Thermal Shock Test TSKT 	Standard: IEC 60068-2-14, Test Na
	Special conditions: <ul style="list-style-type: none"> ▪ Temperature: -30 °C to +80 °C ▪ Temperature variation: 6–30 s ▪ Number of cycles: 600 ▪ Dwell time: 10 minutes
	Operating conditions: Unpowered
	Duration: 9 days

Table 8-5: Thermal Resistance Cycle Stress Tests (Continued)

Designation	Condition
Temperature Change TCH 	Standard: IEC 60068-2-14, Test Nb
	Special conditions: Temperature: -40°C to +90°C Temperature variation: 3 ± 0.6°C/min Number of cycles: 400 Dwell time: 10 minutes
	Operating conditions: Unpowered
	Duration: 29 days

8.2.5 Mechanical Resistance Stress Tests

The following tests the AirPrime WP76XX module's resistance to vibrations and mechanical shocks.

Table 8-6: Mechanical Resistance Stress Tests

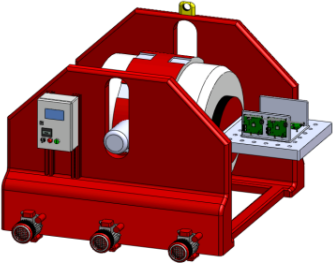
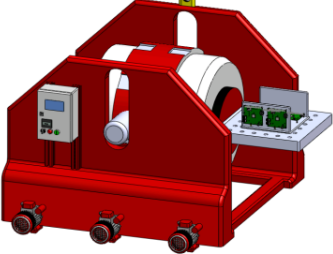
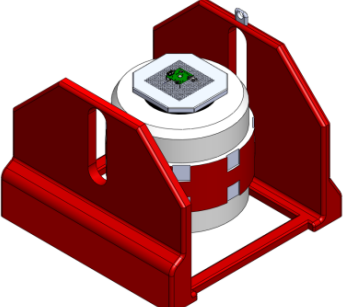
Designation	Condition
Sinusoidal Vibration Test SVT 	Standard: IEC 60068-2-6, Test Fc
	Special conditions: <ul style="list-style-type: none"> ▪ Frequency range: 16 Hz to 1000 Hz ▪ Displacement: 0.35 mm (peak-peak) ▪ Acceleration: <ul style="list-style-type: none"> • 5 g from 16 to 62 Hz • 3 g from 62 to 200 Hz • 1 g from 200 to 1000 Hz ▪ Sweep rate: 1 octave/minute ▪ Number of sweeps: 20 sweeps/axis ▪ Sweep direction: ± X, ± Y, ± Z
	Operating conditions: Unpowered
	Duration: 2 days

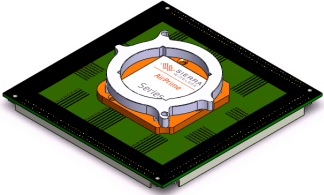

Table 8-6: Mechanical Resistance Stress Tests (Continued)

Designation	Condition
Random Vibration Test RVT 	Standard: IEC 60068-2-64, Test Fh Special conditions: <ul style="list-style-type: none"> ▪ Frequency range: 10 Hz to 2000 Hz ▪ Power Spectral Density in $[(m/s^2)^2/Hz]$ <ul style="list-style-type: none"> • 0.1 g^2/Hz at 10 Hz • 0.01 g^2/Hz at 250 Hz • 0.005 g^2/Hz at 1000 Hz • 0.005 g^2/Hz at 2000 Hz ▪ Peak factor: 3 ▪ Duration per axis: 1 hr/axis Operating conditions: Unpowered Duration: 1 day
Mechanical Shock Test MST 	Standard: IEC 60068-2-27, Test Ea Special conditions: <ul style="list-style-type: none"> ▪ Shock Test 1: <ul style="list-style-type: none"> • Wave form: Half sine • Peak acceleration: 30 g • Duration: 11 ms • Number of shocks: 8 • Direction: $\pm X, \pm Y, \pm Z$ ▪ Shock Test 2: <ul style="list-style-type: none"> • Wave form: Half sine • Peak acceleration: 100 g • Duration: 6 ms • Number of shocks: 3 • Direction: $\pm X, \pm Y, \pm Z$ Operating conditions: Unpowered Duration: 72 hours

8.2.6 Handling Resistance Stress Tests

The following tests the AirPrime WP76XX module's resistance to handling malfunctions and damage.

Table 8-7: Handling Resistance Stress Tests

Designation	Condition
ESDC Test 	Standard: JESD22-A114, JESD22-A115, JESD22-C101
	Special conditions: <ul style="list-style-type: none"> ▪ HBM (Human Body Model): 1 KV (Class 1C) ▪ MM (Machine Model): 100 V ▪ CDM (Charged Device Model): 500 V (Class IV)
	Operating conditions: Powered
	Duration: 3 days
Free Fall Test FFT 1 	Standard: IEC 60068-2-32, Test Ed
	Special conditions: <ul style="list-style-type: none"> ▪ Number of drops: 2 drops per unit ▪ Height: 1 m
	Operating conditions: Unpowered
	Duration: 6 hours

9: Legal Information

This chapter describes the current certification status of the WP7601, WP7601-1, WP7603, WP7603-1, WP7605, WP7607, WP7607-1, WP7608, WP7608-1, WP7609, WP7610, WP7611, WP7611-1, WP7611D, WP7611D-1 modules collectively referred to as the WP76xx series modules or WP76xx module. Certifications in other countries may be attained upon customer request — contact your Semtech account representative for details.

Additional testing and certification may be required for the host product with an embedded WP76xx series module and are the responsibility of the OEM. Semtech offers professional services-based assistance to OEMs with the testing and certification process, if required.

* Limited availability

9.1 Disposing of the Product

This electronic product is subject to the EU Directive 2012/19/EU for Waste Electrical and Electronic Equipment (WEEE). As such, this product must not be disposed of at a municipal waste collection point. Please refer to local regulations for directions on how to dispose of this product in an environmental friendly manner.

9.2 Important Notice

Due to the nature of wireless communications, transmission and reception of data can never be guaranteed. Data may be delayed, corrupted (i.e., have errors) or be totally lost. Although significant delays or losses of data are rare when wireless devices such as the Semtech modem are used in a normal manner with a well-constructed network, the Semtech modem should not be used in situations where failure to transmit or receive data could result in damage of any kind to the user or any other party, including but not limited to personal injury, death, or loss of property. Semtech accepts no responsibility for damages of any kind resulting from delays or errors in data transmitted or received using the Semtech modem, or for failure of the Semtech modem to transmit or receive such data.

9.3 Safety and Hazards

Do not operate your AirPrime WP76XX embedded module:

- In areas where blasting is in progress
- Where explosive atmospheres may be present including refueling points, fuel depots, and chemical plants
- Near medical equipment, life support equipment, or any equipment which may be susceptible to any form of radio interference.

In such areas, the AirPrime WP76XX modem **MUST BE IN AIRPLANE MODE OR POWERED OFF**. Otherwise, the AirPrime WP76XX modem can transmit signals that could interfere with this equipment.

In an aircraft, the AirPrime WP76XX modem **MUST BE IN AIRPLANE MODE OR POWERED OFF**. Otherwise, the AirPrime WP76XX modem can transmit signals that could interfere with various onboard systems and may be dangerous to the operation of the aircraft or disrupt the cellular network. Use of a cellular phone in an aircraft is illegal in some jurisdictions. Failure to observe this instruction may lead to suspension or denial of cellular telephone services to the offender, or legal action or both.

Some airlines may permit the use of cellular phones while the aircraft is on the ground and the door is open. The AirPrime WP76XX modem may be used normally at this time.

9.4 Compliance Acceptance and Certification

The WP7603, WP7610, WP7611, WP7611D are designed to be compliant with the 3GPP Release 8 UTRA and Release 10 E-UTRA Specifications for Mobile Terminated Equipment. The WP7601 is designed to be compliant with the 3GPP Release 10 E-UTRA Specification for Mobile Terminated Equipment.

Final regulatory and operator certification requires regulatory agency testing and approval with the fully integrated UE host device incorporating the AirPrime WP76XX module.

The OEM host device and, in particular, the OEM antenna design and implementation will affect the final product functionality, RF performance, and certification test results.

Note: Tests that require features not supported by the AirPrime WP76XX (as defined by this document) are not supported.

9.5 Certification Compliance

9.5.1 Important Compliance Information for North American Users

The WP7603, WP7610, WP7611, WP7611D modules, upon commercial release, will have been granted modular approval for mobile applications. Integrators may use these modules in their final products without additional FCC/IC (Industry Canada) certification if they meet the following conditions. Otherwise, additional FCC/IC approvals must be obtained.

1. The end product must use the RF trace design approved with the WP7603, WP7610, WP7611, WP7611D. The Gerber file of the trace design can be obtained from Semtech upon request.
2. At least 20 cm separation distance between the antenna and the user's body must be maintained at all times.
3. To comply with FCC/IC regulations limiting both maximum RF output power and human exposure to RF radiation, the maximum antenna gain including cable loss in a mobile-only exposure condition must not exceed the limits stipulated in [Table 9-1](#) on page 130.

Table 9-1: Antenna Gain Specifications

Device	Technology	Band	Frequency (MHz)	Maximum Antenna Gain (dBi)
WP7601	LTE	4	1710–1755	6
		13	777–787	6
WP7603	LTE	2	1850–1910	6
		4	1710–1755	6
		5	824–849	6
		12	699–716	6
	UMTS	2	1850–1910	6
		4	1710–1755	6
		5	824–849	6

Table 9-1: Antenna Gain Specifications (Continued)

Device	Technology	Band	Frequency (MHz)	Maximum Antenna Gain (dBi)	
WP7610	LTE	2	1850–1910	6	
		4	1710–1755	6	
		5	824–849	6	
		12	699–716	6	
		13	777–787	6	
		14	788–798	6	
		17	704–716	6	
		66	1710–1780	6	
	UMTS	2	1850–1910	6	
		4	1710–1755	6	
		5	824–849	6	
	WP7611 WP7611D	LTE	2	1850–1910	6
			4	1710–1755	6
5			824–849	6	
12			699–716	6	
13			777–787	6	
14			788–798	6	
25			1850–1915	6	
26			814–849	6	
66			1710–1780	6	
71			663–698	6	
WP7611 WP7611D	UMTS	2	1850–1910	6	
		4	1710–1755	6	
		5	824–849	6	

4. The WP7601, WP7603, WP7610, WP7611, WP7611D may transmit simultaneously with other collocated radio transmitters within a host device, provided the following conditions are met:
- Each collocated radio transmitter has been certified by FCC/IC for mobile application.
 - At least 20 cm separation distance between the antennas of the collocated transmitters and the user's body must be maintained at all times.
 - The radiated power of a collocated transmitter must not exceed the EIRP limit stipulated in [Table 9-2](#) on page 132.

Table 9-2: Collocated Radio Transmitter Specifications

Device	Technology	Frequency (MHz)	EIRP Limit (dBm)
Collocated transmitters ^a	WLAN	2400–2500	25
		5150–5850	27
	WiMAX	2300–2400	25
		2500–2700	25
		3300–3800	25
	BT	2400–2500	15

a. Valid collocated transmitter combinations: WLAN+BT; WiMAX+BT. (WLAN+WiMAX+BT is not permitted.)

5. A label must be affixed to the outside of the end product into which the WP7601, WP7603, WP7610, WP7611, WP7611D is incorporated, with a statement similar to the following:
 - **(WP7601)**— This device contains FCC ID: N7NWP76A/ IC:2417C-WP76A.
 - **(WP7603)**— This device contains FCC ID: N7NWP76C/ IC:2417C-WP76C.
 - **(WP7610)**— This device contains FCC ID: N7NWP7610/ IC:2417C-WP7610.
 - **(WP7611, WP7611D)**— This device contains FCC ID: N7NWP76B/ IC:2417C-WP76B.
6. A user manual with the end product must clearly indicate the operating requirements and conditions that must be observed to ensure compliance with current FCC/IC RF exposure guidelines.

The end product with an embedded WP7601, WP7603, WP7610, WP7611, WP7611D may also need to pass the FCC Part 15 unintentional emission testing requirements and be properly authorized per FCC Part 15.

Note: If this module is intended for use in a portable device, you are responsible for separate approval to satisfy the SAR requirements of FCC Part 2.1093 and IC RSS-102.

9.5.2 Japan Regulatory Compliance

The AirPrime WP7605 has been granted regulatory approval in Japan with the following certification numbers:

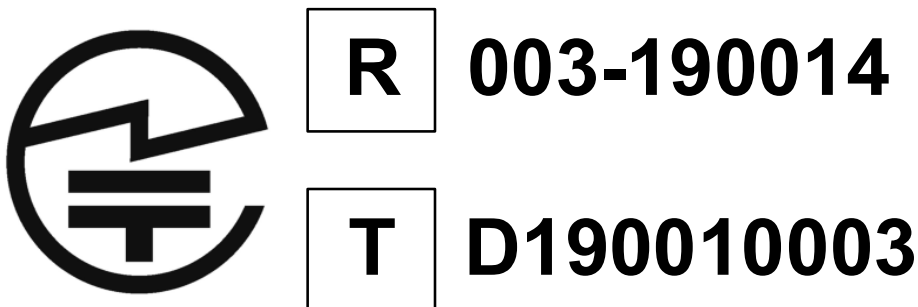


Figure 9-1: Japan Certification

9.5.3 Taiwan Regulatory Compliance



Figure 10: Taiwan NCC logo

10: Pinout

The system interface of the AirPrime WP76XX is through the LGA pattern on the bottom of the PCB.

AirPrime WP76XX pins are divided into three functional categories:

- Core functions and associated pins — Cover all the mandatory features for M2M connectivity and will be available by default across all CF3 family of modules. These Core functions are always available and always at the same physical pin locations. A customer platform using only these functions and associated pins is guaranteed to be forward and/or backward compatible with the next generation of CF3 modules.
- Extension functions and associated pins — Bring additional capabilities to the customer. Whenever an Extension function is available on a module, it is always at the same pin location.
- Custom functions and associated pins — These are module-specific and make use of specific chipset functions and I/Os.

Warning: *Custom features should be used with caution as there is no guarantee that the custom functions available on a given module will be available on other CF3 modules.*

Pins marked as "Leave open" or "Reserved" should not be used or connected.

10.1 Pin Configuration

Figure 10-1 illustrates the pin configuration of the AirPrime WP76XX module.



Figure 10-1: Pin Configuration (Top View, Through Module)

10.2 Pin Description

Table 10-1 on page 136 lists detailed information for the LGA pins.

Note: Some pin numbers (112, 126, 127, 137, 138, 235) do not appear in this table because there are no corresponding pads on the module's PCB.

Table 10-1: Pin Definitions

Pin	Signal name	Group	I/O ^a	Voltage	PU / PD ^b	Active	If unused	Function	Type
1	I2C1_CLK	I2C	I/O	1.8V	PU		Leave open	I ² C clock	Core
2	UART1_RI ^{c,d}	UART1	O	1.8V		L	Leave open	UART1 Ring indicator	Core
<i>Note: Do not install external pull-up on this pin, otherwise the module will not boot.</i>									
3	UART1_RTS ^c	UART1	I	1.8V		L	Leave open	UART1 Request to send	Core
4	UART1_CTS ^c	UART1	O	1.8V		L	Leave open	UART1 Clear to send	Core
5	UART1_TX ^c	UART1	I	1.8V			Leave open	UART1 Transmit data	Core
6	UART1_RX ^c	UART1	O	1.8V			Leave open	UART1 Receive data	Core
7	UART1_DTR ^{c,e}	UART1	I	1.8V		L	Leave open	UART1 Data terminal ready	Core
8	UART1_DCD ^{c,d}	UART1	O	1.8V		L	Leave open	UART1 Data carrier detect	Core
<i>Note: Do not install external pull-up on this pin, otherwise the module will not boot.</i>									
9	UART1_DSR ^{c,d}	UART1	O	1.8V		L	Leave open	UART1 Data set ready	Core
<i>Note: Do not install external pull-up on this pin, otherwise the module will not boot.</i>									
10	GPIO2 ^e	GPIO	I/O	1.8V	NP		Leave open	General purpose I/O	Core
11	RESET_IN_N	Control signal	I	1.8V	PU	L	Leave open	Input reset signal	Core
12	USB_D-	USB	I/O				Leave open	USB Data negative	Core
13	USB_D+	USB	I/O				Leave open	USB Data positive	Core
14	HSIC_DATA	HSIC	I/O	1.2V			See footnote ^f	High Speed Inter-Chip Data	Extension
15	HSIC_STRB	HSIC	I/O	1.2V			See footnote ^f	High Speed Inter-Chip Strobe	Extension
16	USB_VBUS	USB	I	5V or VBAT_BB			Optional connection (If USB interface is required then connect to USB_VBUS or (if unavailable) VBAT_BB, otherwise leave open.)	USB power supply	Core
17–20	Reserved	No Connection					See footnote ^g .		Extension
21	Reserved	No Connection					Leave open		Extension
22	SYS_CLK	Clock	O				Leave open	19 MHz digital clock output	Extension

Table 10-1: Pin Definitions (Continued)

Pin	Signal name	Group	I/O ^a	Voltage	PU / PD ^b	Active	If unused	Function	Type
23	SLEEP_CLK	Clock	O				Leave open	32.768 kHz digital clock output	Extension
24	ADC1	ADC	I				Leave open	Analog to digital conversion	Core
25	ADC0	ADC	I				Leave open	Analog to digital conversion	Core
26	UIM1_VCC	UIM1	O	1.8V/3V			Mandatory connection	1.8V/3V UIM1 Power supply	Core
27	UIM1_CLK	UIM1	O	1.8V/3V			Mandatory connection	UIM1 Clock	Core
28	UIM1_DATA	UIM1	I/O	1.8V/3V			Mandatory connection	UIM1 Data	Core
29	UIM1_RESET_N	UIM1	O	1.8V/3V		L	Mandatory connection	UIM1 Reset	Core
30	GND	Ground	0V	0V			Mandatory connection	Diversity antenna ground	Extension
31	RF_DIV	RF					Mandatory connection	Diversity antenna	Extension
32	GND	Ground	0V	0V			Mandatory connection	Diversity antenna ground	Extension
33	PCM_OUT	PCM	O	1.8V			Leave open	PCM data out	Core
	I2S_OUT	I2S	O	1.8V			Leave open	I2S data out	
34	PCM_IN	PCM	I	1.8V			Leave open	PCM data in	Core
	I2S_IN	I2S	I	1.8V			Leave open	I2S data in	
35	PCM_SYNC	PCM	Pri: I/O Aux: O	1.8V			Leave open	PCM sync	Core
	I2S_WS	I2S	O	1.8V			Leave open	I2S word select	
36	PCM_CLK	PCM	Pri: I/O Aux: O	1.8V			Leave open	PCM clock	Core
	I2S_CLK	I2S	O	1.8V			Leave open	I2S clock	
37	GND	RF	0V	0V			Mandatory connection	GNSS antenna ground	Core
38	RF_GNSS ^h	RF					Leave open	RF GNSS input	Extension
39	GND	RF	0V	0V			Mandatory connection	GNSS antenna ground	Core
40	GPIO7	GPIO	I/O	1.8V	NP		Leave open	General purpose I/O	Core
41	GPIO8	GPIO	I/O	1.8V	NP		Leave open	General purpose I/O	Core
42	DR_SYNC ^h	GPS	O	1.8V			Leave open	GPS dead reckoning sync	Extension

Table 10-1: Pin Definitions (Continued)

Pin	Signal name	Group	I/O ^a	Voltage	PU / PD ^b	Active	If unused	Function	Type
43	EXT_GPS_LNA_EN	Control signal	O	1.8V		H	Leave open	External GNSS LNA enable	Extension
44	GPIO13	GPIO	I/O	1.8V	NP		Leave open	General purpose I/O	Extension
45	VGPI0	Voltage reference	O	1.8V			Leave open	GPIO voltage output	Core
46	GPIO6 ^j	GPIO	I/O	1.8V	NP		Leave open	General purpose I/O	Core
47	TP1 (Boot pin)	Boot	I	1.8V		L	Mandatory test point	Test point 1 <ul style="list-style-type: none"> ▪ 0—Download mode ▪ Open—Normal mode 	Extension
48	GND	RF	0V	0V			Mandatory connection	Main antenna ground	Core
49	RF_MAIN	RF					Mandatory connection	Main RF antenna	Core
50	GND	RF	0V	0V			Mandatory connection	Main antenna ground	Core
51	SPI1_MRDY	SPI1	O	1.8V			Leave open	SPI Master Ready	Core
52	SPI1_MISO	SPI1	I	1.8V			Leave open	SPI Master Input/Slave Output (output from slave)	Core
53	SPI1_CLK	SPI1	O	1.8V			Leave open	SPI serial clock (output from Master)	Core
54	SPI1_MOSI	SPI1	O	1.8V			Leave open	SPI Master Output/Slave Input (output from master)	Core
55	Reserved	No Connection					See footnote ^k .		Core
56	Reserved	No Connection					See footnote ^k .		Core
57	Reserved	No Connection					See footnote ^k .		Core
58	Reserved	No Connection					See footnote ^k .		Core
59	POWER_ON_N	Control	I	1.8V	PU	L	Mandatory connection	Power On control signal	Core
60	TX_ON	Indication	O	1.8V		H	Leave open	Tx activity indicator	Extension
61	VBAT_RF	Power	I	3.4V (min) 3.7V (typ) 4.3V (max)			Mandatory connection	RF power supply (see Power Supply Ratings on page 31)	Core

Table 10-1: Pin Definitions (Continued)

Pin	Signal name	Group	I/O ^a	Voltage	PU / PD ^b	Active ^e	If unused	Function	Type
62	VBAT_RF	Power	I	3.4V (min) 3.7V (typ) 4.3V (max)			Mandatory connection	RF power supply (see Power Supply Ratings on page 31)	Core
63	VBAT_BB	Power	I	3.4V (min) 3.7V (typ) 4.3V (max)			Mandatory connection	Baseband power supply (see Power Supply Ratings on page 31)	Core
64	UIM1_DET ^e	UIM1		1.8V			Mandatory connection	Detect UIM1 insertion/removal. (Pin must be open to detect the UIM, or grounded if no UIM is present.)	Core
65	GPIO4 ^l	GPIO	I/O	1.8V	NP		Leave open	General purpose I/O	Extension
66	I2C1_Data	I2C	I/O	1.8V	PU		Leave open	I ² C data	Core
67–70	GND	Ground	0V	0V			Mandatory connection	Ground	Core
71–90	Reserved	No Connection					See footnote ^g .		
91	USB_ID	USB	I				Leave open	Reserved for use with USB OTG	Extension
92	GPIO38 ^{e,m,n,o}	GPIO	I/O	1.8V	NP		Leave open	General purpose I/O	Extension
93	Reserved	No Connection					See footnote ^g .		
94	GPIO40 ^{n,o,p}	GPIO	I/O	1.8V	NP		Leave open	General purpose I/O	Extension
95	GPIO41 ^{n,o,p}	GPIO	I/O	1.8V	NP		Leave open	General purpose I/O	Extension
96	UART2_TX ^c	UART2	I	1.8V			Leave open	UART2 Transmit data	Extension
97	UART2_RX ^c	UART2	O	1.8V			Leave open	UART2 Receive data	Extension
98	UART2_RTS ^c	UART2	I	1.8V			Leave open	UART2 Request To Send	Extension
99	UART2_CTS ^c	UART2	O	1.8V			Leave open	UART2 Clear To Send	Extension
100	Reserved	No Connection					See footnote ^g .		
101	GPIO35	GPIO	I/O	1.8V	NP		Leave open	General purpose I/O	Extension
102	GPIO36 ^{e,m,n,o}	GPIO	I/O	1.8V	NP		Leave open	General purpose I/O	Extension
103	GPIO37 ^{n,o}	GPIO	I/O	1.8V	NP		Leave open	General purpose I/O	Extension
104	GPIO32	GPIO	I/O	1.8V	NP		Leave open	General purpose I/O	Extension
105	GPIO33	GPIO	I/O	1.8V	NP		Leave open	General purpose I/O	Extension
106	WWAN_LED_N	Indication	O	VBAT_BB ^q		L	Leave open		Extension

Table 10-1: Pin Definitions (Continued)

Pin	Signal name	Group	I/O ^a	Voltage	PU / PD ^b	Active ^e	If unused	Function	Type
107	ADC2 ^{m,o}	ADC	I				Leave open		Extension
108	ADC3 ^{m,o}	ADC	I				Leave open		Extension
109	GPIO42 ^e	GPIO	I/O	1.8V	NP		Leave open	General purpose I/O	Extension
110	WAKE_ON_WWAN	Indication	O	1.8V		H	Leave open	Driven high to wake the host when specific events occur.	Extension
111	GND	Ground	OV	OV			Mandatory connection	Diversity antenna ground	Core
113	GND	Ground	OV	OV			Mandatory connection	Diversity antenna ground	Core
114 – 124	Reserved	No Connection					See footnote ^g .		
125	GND	RF	OV	OV			Mandatory connection	GNSS antenna ground	Core
128	GND	RF	OV	OV			Mandatory connection	GNSS antenna ground	Core
129 – 135	Reserved	No Connection					See footnote ^g .		
136	GND	RF	OV	OV			Mandatory connection	Main antenna ground	Core
139	GND	RF	OV	OV			Mandatory connection	Main antenna ground	Core
140 – 146	Reserved	No Connection					See footnote ^g .		
147	GPIO21 ^e	GPIO	I/O	1.8V	NP		Leave open	General purpose I/O	Core
148	GPIO22	GPIO	I/O	1.8V	NP		Leave open	General purpose I/O	Core
149	GPIO23	GPIO	I/O	1.8V	NP		Leave open	General purpose I/O	Core
150	GPIO24	GPIO	I/O	1.8V	NP		Leave open	General purpose I/O	Core
151	W_DISABLE_N	Control	I	1.8V		L	Leave open	Wireless disable (main RF radio)	Core
152	SAFE_PWR_REMOVE	Indication	O	1.8V		H	Leave open	Indicate to host that Main DC power can be removed	Extension
153	ANT_CNTLO	Antenna control	O	1.8V			Leave open		Extension
	GPIO28 ^f	GPIO	I/O	1.8V			Leave open	General purpose I/O	Extension

Table 10-1: Pin Definitions (Continued)

Pin	Signal name	Group	I/O ^a	Voltage	PU / PD ^b	Active	If unused	Function	Type
154	ANT_CNTL1	Antenna control	O	1.8V			Leave open		Extension
	GPIO29 ^f	GPIO	I/O	1.8V			Leave open	General purpose I/O	Extension
155	ANT_CNTL2	Antenna control	O	1.8V			Leave open		Extension
	GPIO30 ^f	GPIO	I/O	1.8V			Leave open	General purpose I/O	Extension
156	ANT_CNTL3	Antenna control	O	1.8V			Leave open		Extension
	GPIO31 ^f	GPIO	I/O	1.8V			Leave open	General purpose I/O	Extension
157	VBAT_RF	Power	I	3.4V (min) 3.7V (typ) 4.3V (max)			Optional connection	RF power supply (see Power Supply Ratings on page 31)	Core
158	VBAT_BB	Power	I	3.4V (min) 3.7V (typ) 4.3V (max)			Optional connection	Baseband power supply (see Power Supply Ratings on page 31)	Core
159	GPIO25	GPIO	I/O	1.8V	NP		Leave open	General purpose I/O	Core
160	Reserved	No Connection					See footnote ^g .		
161	SDIO_CMD	SDIO	O	1.8V/ 2.85V			Leave open	SDIO command	Extension
162	SDIO_CLK	SDIO	O	1.8V/ 2.85V			Leave open	SDIO clock	Extension
163	SDIO_DATA_3	SDIO	I/O	1.8V/ 2.85V			Leave open	SDIO data bit 3	Extension
164	SDIO_DATA_2	SDIO	I/O	1.8V/ 2.85V			Leave open	SDIO data bit 2	Extension
165	SDIO_DATA_1	SDIO	I/O	1.8V/ 2.85V			Leave open	SDIO data bit 1	Extension
166	SDIO_DATA_0	SDIO	I/O	1.8V/ 2.85V			Leave open	SDIO data bit 0	Extension
167 _ 234	GND	Ground	0V	0V			Mandatory connection	Ground	Core
236	J1 ⁵			1.8V		L	Mandatory test point	Test point	Extension
237	J2 ⁵			1.8V			Mandatory test point	Test point	Extension
238	J3 ⁵			1.8V			Mandatory test point	Test point	Extension
239	J4 ⁵			1.8V			Mandatory test point	Test point	Extension

Table 10-1: Pin Definitions (Continued)

Pin	Signal name	Group	I/O ^a	Voltage	PU / PD ^b	Active	If unused	Function	Type
240	J5 ^s			1.8V		L	Mandatory test point	Test point	Extension
241	J6 ^s			1.8V			Mandatory test point	Test point	Extension
242	J7 ^s			1.8V			Mandatory test point	Test point	Extension
243	J8 ^s			1.8V			Mandatory test point	Test point	Extension
244	J9 ^s			1.8V			Mandatory test point	Test point	Extension

- a. Signal direction with respect to the module. Examples: PCM_OUT (pin 33) is an output from the module to the host; PCM_IN (pin 34) is an input to the module from the host.
- b. NP—No Pull; PD—Pull Down; PU—Pull Up
- c. (UART signals only) Signals are named with respect to the host device. For example, UART1_RX is the signal used by the host to receive data from the module.
- d. Do not install external pull-up on this pin, otherwise the module will not boot.
- e. Pin is 'wakeable'. Can be used to trigger the module to wake up from USB-SS mode (low power active state). See [Wakeup Interrupt \(Sleep State\)](#) on page 90 for details.
- f. If HSIC bus is not used on the host application, refer to [HSIC Bus](#) on page 101 for recommended methods for disabling the interface.
- g. Pins are not connected internally, but are reserved for future use. Leave them unconnected to ensure compatibility with other Sierra Wireless CF3 modules.
- h. Support is SKU-dependent.
- j. Refer to [GPIO6](#) on page 89 for functional details.
- k. Pins are reserved for future use. Leave them unconnected to ensure compatibility with other Sierra Wireless CF3 modules.
- l. GPIO4 can be used for external UIM2 detect.
- m. Can be configured as a wakeup trigger for ULPS. See [Power Consumption States](#) on page 33 and [Wakeup Events \(ULPS\)](#) on page 91 for details.
- n. Accessible via sysfs/Legato only.
- o. Only available in Group A variants; this pin is Reserved in Group B variants.
- p. GPIO40 and GPIO41 may be unavailable in future WP products.
- q. Maximum rating is VBAT_BB + 0.5V, with maximum current sink capability of 40 mA.
- r. This pin is available for use when configured using AT+WIOCFG.
- s. Accessibility restricted to soldered-down modules. Not available for socket-mounted modules.

Table 10-2: RF Pin Information

Signal name	Pin #	Description
RF_DIV	31	Diversity input
RF_GNSS ^a	38	RF GNSS input
RF_MAIN	49	Main RF port (input/output)

- a. Support is SKU-dependent

Table 10-3: Supply Pin Information

Signal name	Pin #	Description
VBAT_RF	61, 62, 157	RF power supply

Table 10-3: Supply Pin Information

Signal name	Pin #	Description
VBAT_BB	63, 158	Baseband power supply
USB_VBUS	16	Connected to USB_VBUS (5V) or (if unavailable) VBAT_BB

Table 10-4: Ground & Reserved Pin Information

Signal name	Pin #	Description
Ground	30, 32, 37, 39, 48, 50, 67–70, 111, 113, 125, 128, 136, 139, 167–234	Ground connection
Reserved	17–21, 55–58, 65, 71–90, 93, 100, 114–124, 129–135, 140–146, 160	Pins are not connected internally, but are reserved for future use. Leave them unconnected to ensure compatibility with other Sierra Wireless CF3 modules.

11: Customization

Subject to commercial terms, Semtech can supply custom-configured modems to facilitate a carrier's network and performance requirements. Semtech also offers a standard configuration for each country.

Custom configurations are entered into a selector spreadsheet that Semtech supplies. A unique part number is assigned to each custom configuration to facilitate customer ordering.

Table 11-1: Customizable Features

Name	Description	Default
Display of IMSI	Display of International Mobile Subscriber Identity via AT+CIMI command	Display enabled
UART baud rate	Default UART speed	115200 bps
UART enabled	Defines whether UART port is enabled by default or not	UART disabled

12: Testing

12.1 Certification Testing

Note: Typically, certification testing of your device with the integrated module is required one time only.

The AirPrime WP76XX module has been certified as described in [Compliance Acceptance and Certification](#) on page 130.

When you produce a host device with a Semtech AirPrime embedded module, you must obtain certifications for the final product from appropriate regulatory bodies in the jurisdictions where it will be distributed.

The following are *some* of the regulatory bodies from which you may require certification—it is your responsibility to make sure that you obtain all necessary certifications for your product from these or other groups:

- FCC (Federal Communications Commission — www.fcc.gov)
- Industry Canada (www.ic.gc.ca)
- GCF (Global Certification Forum — www.globalcertificationforum.org) outside of North America
- PTCRB (PCS Type Certification Review Board — www.ptcrb.com) in North America

12.2 Production Testing

Note: Production testing typically continues for the life of the product.

Production testing ensures that, for each assembled device, the module is installed correctly (I/O signals are passed between the host and module), and the antenna is connected and performing to specifications (RF tests).

Typical items to test include:

- Host connectivity
- Baseband (host/module connectors)
- RF assembly (Tx and/or Rx, as appropriate)
- Network availability
- Host/device configuration issues

*Note: The number and types of tests to perform are **your** decision—the tests listed in this section are guidelines only. Make sure that the tests you perform exercise functionality to the degree that **your** situation requires.*

Use an appropriate test station and use AT commands to control the integrated module.

Note:

- *Your test location must be protected from ESD to avoid interference with the module and antenna(s), assuming that your test computer is in a disassembled state. Also, consider using an RF shielding box—local government regulations may prohibit unauthorized transmissions.*
 - *The tests described in this chapter are done using a Linux O/S (e.g. Ubuntu 12.04).*
-

12.3 Functional Production Test

This section presents a suggested procedure for performing a basic manual functional test on a laboratory bench using an AirPrime WP76XX module and a hardware development kit. When you have become familiar with the testing method, use it to develop your own automated production testing procedures.

12.3.1 Suggested Production Tests

Consider the following tests when you design your production test procedures for devices with the AirPrime module installed.

- Visual check of the module’s connectors and RF assemblies
- Module is operational
- USB connection is functional
- LED is functional
- Power on/off
- Firmware revision check
- Rx tests on main and auxiliary paths
- Tx test

12.3.2 Production Test Procedure

The following is a suggested test plan — you must decide which tests are appropriate for your product. You may wish to add additional tests that more fully exercise the capabilities of your product.

Using an appropriate test station, and referring to the appropriate AT command references:

1. Visually inspect the module for obvious defects (such as tainted or damaged shields) before installing it in the test station.
2. Ensure that the module is powered off (no voltage on VBAT_BB/VBAT_RF) before beginning your tests.
3. Determine whether any USB devices are currently connected to the computer:
 - a. Open a shell window and enter the command **ls /dev/tty/USB***.
 - b. Record the `ttyUSBn` values that are returned; these are the currently connected USB devices. If the command returns “no such file or directory”, there are no devices currently connected.
4. Provide power to the module (voltage on VBAT_BB/VBAT_RF).
5. Test POWER_ON_N — Turn on the module by driving POWER_ON_N low, as shown in [Figure 4-1](#) on page 82.
6. Test USB functionality — Check for USB enumeration.

Enter the command **ls /dev/tty/USB*** and then record and compare the results with those from [Step 3](#). If there are any new `ttyUSBn` devices, then the modem has enumerated successfully. (The AT port is usually the *last* new device.)
7. Make sure your modem is connected and running, and then establish contact with the module:

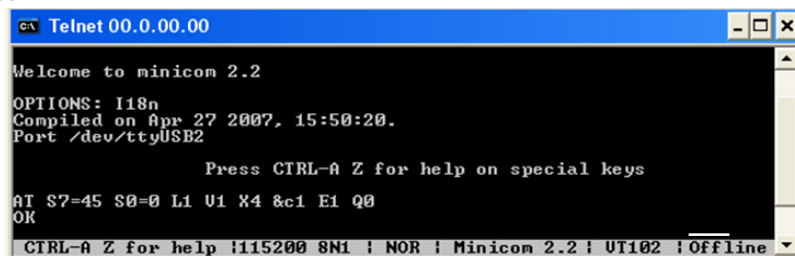
Use a terminal emulation/communications program such as `minicom` to connect over the device handle for AT commands (see listings in [Step 6](#)):

Note: If the command “minicom” is not found, then use a different program, or download minicom and repeat this step. See [Downloading and Configuring minicom for Linux Systems](#) on page 147 for details.

- a. Start `minicom`:

- First use of the modem: From the command line, type `minicom -s`. (The `-s` switch shows the configuration menu.)
- Subsequent uses: From the command line, type `minicom`. (The `-s` switch is assumed.)

The minicom configuration details appear and the message OK appears when the connection is established.



```

Telnet 00.0.00.00
Welcome to minicom 2.2
OPTIONS: I18n
Compiled on Apr 27 2007, 15:50:20.
Port /dev/ttyUSB2
Press CTRL-A Z for help on special keys
AT S7=45 S0=0 L1 U1 X4 &c1 E1 Q0
OK
CTRL-A Z for help !115200 8N1 ! NOR ! Minicom 2.2 ! UT102 ! Offline

```

8. Display the firmware version:
 - `ATI`
9. Unlock the extended AT command set. (Note: Use `AT!ENTERCND?` to check command syntax, which is SKU-dependent.):
 - `AT!ENTERCND=<password>`
10. Test the LED — Visually confirm that the LED turns on and off using:
 - `AT!LDTEST=0,1` (LED on)
 - `AT!LDTEST=0,0` (LED off)
11. Put the module in diagnostic / factory test mode:
 - `AT!DAFTMACT`
12. Communicate with the SIM using `AT+CPIN` or `AT+CIMI`.
13. Test RF transmission, if desired:
 - (UMTS) See [UMTS \(WCDMA/GSM\) RF Transmission Path Test](#) on page 148.
 - (LTE) See [LTE RF Transmission Path Test](#) on page 150.
14. Test RF reception, if desired:
 - (UMTS) See [UMTS \(WCDMA/GSM\) RF Receive Path Test](#) on page 154.
 - (LTE) See [LTE RF Receive Path Test](#) on page 157.
15. Test standalone GNSS functionality — See [GNSS RF Receive Path Test](#) on page 160.
16. Remove power from the module.

12.3.2.1 Downloading and Configuring minicom for Linux Systems

Note: This procedure is for Ubuntu systems. If you are using a different Linux distribution, use the appropriate commands for your system to download minicom.

To download and configure minicom in a Ubuntu system:

Note: To install minicom, you must have root access, or be included in the sudoers list.

1. Download and install minicom — enter the following command:
`sudo apt-get install minicom`

2. When prompted, enter your user password to begin the download and installation. When minicom is installed, the shell prompt appears.
3. Configure minicom to communicate with your modem:
 - a. Start minicom with the following command:
`minicom -s`
4. Use the down-arrow key to select the **Serial port setup** option.
5. Refer to [Step 6](#) on page 146 to identify the device file handle (/dev/ttyUSBn) used for AT commands.
6. Indicate the file handle to use for AT commands—Enter A and then replace the serial device string with the AT file handle.
7. Press **Enter** twice.
8. Use the down-arrow key to select **Save setup as dfl**.
9. Select **Exit**.

12.4 UMTS (WCDMA/GSM) RF Transmission Path Test

Important: *As of the publication date of this document, the test procedure described is to be considered preliminary, pending implementation of some commands in a future firmware upgrade.*

Note: This procedure segment is performed in [Step 13](#) of the [Production Test Procedure](#) on page 146.

The suggested test procedure that follows uses the parameters in the following tables.

Table 12-1: Test Settings — WP7603 UMTS Transmission Path

	Band	Frequency (MHz)	Band ID	Channel ^a
1900 MHz	B2	1880.0	15 ^b	9400
1700 MHz	B4	1732.4	28	1412
850 MHz	B5	836.4	22	4182

- a. Channel value used by the !DASCHAN command (!DASCHAN uses uplink (Tx) channel at the center of the corresponding band, for both Tx and Rx testing)
- b. Either 15 (WCDMA1900A) or 16 (WCDMA1900B) may be used for testing.

Table 12-2: Test Settings — WP7607 / WP7608 UMTS Transmission Path

	Band	Frequency (MHz)	Band ID	Tx Channel ^a
2100 MHz	B1	1950.0	9	9750
900 MHz	B8	897.6	29	2788

- a. Channel values shown are at the center of the corresponding bands.

Table 12-3: Test Settings — WP7609 UMTS Transmission Path

	Band	Frequency (MHz)	Band ID	Tx Channel ^a
2100 MHz	B1	1950.0	9	9750
850 MHz	B5	836.4	22	4182
900 MHz	B8	897.6	29	2788

a. Channel values shown are at the center of the corresponding bands.

Table 12-4: Test Settings — WP7610 UMTS Transmission Path

	Band	Frequency (MHz)	Band ID	Channel ^a
1900 MHz	B2	1880.0	15 ^b	9400
1700 MHz	B4	1732.4	28	1412
850 MHz	B5	836.4	22	4182

a. Channel value used by the !DASCHAN command (!DASCHAN uses uplink (Tx) channel at the center of the corresponding band, for both Tx and Rx testing)
 b. Either 15 (WCDMA1900A) or 16 (WCDMA1900B) may be used for testing.

Table 12-5: Test Settings — WP7607 / WP7608 / WP7609 2G Transmission Path

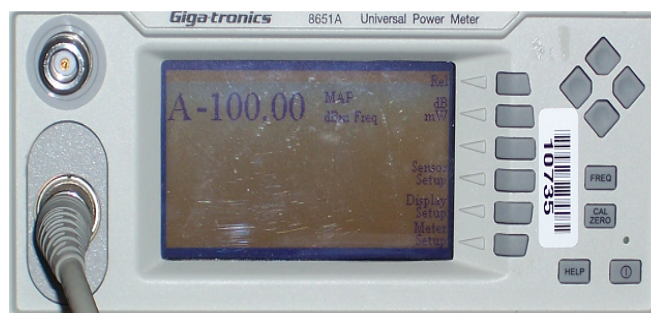
Band		Frequency (MHz)	Band ID	Tx Channel ^a
900 MHz	E-GSM 900	897.4	10	37
1800 MHz	DCS 1800	1747.8	11	700

a. Channel values shown are at the center of the corresponding bands.

To test the DUT's transmitter path:

Note: This procedure describes steps using the 'Power Meter: Gigatronics 8651A' (with Option 12 and Power Sensor 80701A).

1. Set up the power meter:



- Make sure the meter has been given sufficient time to warm up, if necessary, to enable it to take accurate measurements.
- Zero-calibrate the meter.
- Enable MAP mode.

2. Prepare the DUT using the following AT commands:
 - a. **ATIENTERCND=<password>** (Unlock extended AT command set.)
 - b. **ATIDAFTMACT** (Enter test mode.)
 - c. **ATIDASBAND=<bandValue>** (Set frequency band.)
 - See tables 12-1–12-6 for appropriate <bandValue> values
 - d. **ATIDASCHAN=<channel>** (Set modem channel)
 - See tables 12-1–12-6 for appropriate <channel> values
 - e. **ATIDASTXON** (Turns on the transmit path.)
 - f. **ATIDAWSTXPWR=1,15** (Begin transmitting at requested power level.)
 - g. Take the measurement.
 - h. Repeat [Step f](#) with different power levels if desired.
 - i. **ATIDAWSTXPWR=0,0** (Reduce Tx power to 0, so next time transmitter is turned on, it will come on with 0 dBm power.)
 - j. **ATIDASTXOFF** (Turn off the transmitter.)
3. Test limits — Run ten or more good DUTs through this test procedure to obtain a nominal output power value.
 - Apply a tolerance of ± 5 to 6 dB to each measurement (assuming a good setup design).
 - Monitor these limits during mass-production ramp-up to determine if further adjustments are needed.
 - For GSM mode, the transmit signal is bursted, so the transmit power will appear averaged on the power meter reading.

Note:

- The module has a nominal output power of +23 dBm ± 1 dB in WCDMA mode. However, the value measured by the power meter is significantly influenced (beyond the stated ± 1 dB output power tolerance) by the test setup (host RF cabling loss, antenna efficiency and pattern, test antenna efficiency and pattern, and choice of shield box).
- When doing the same test over the air in an RF chamber, values are likely to be significantly lower.

12.5 LTE RF Transmission Path Test

Important: As of the publication date of this document, the test procedure described is to be considered preliminary, pending implementation of some commands in a future firmware upgrade.

Note: This procedure segment is performed in [Step 13](#) of the [Production Test Procedure](#) on page 146.

The suggested test procedure that follows uses the parameters in the following tables.

Table 12-6: Test Settings — WP7601 LTE Transmission Path

Band		Frequency (MHz)	Band ID	Channel ^a
1700 MHz	B4	1732.4	42	20175
700 MHz	B13	782.0	36	23230

a. Channel value used by the !DASCHAN command (!DASCHAN uses uplink (Tx) channel at the center of the corresponding band, for both Tx and Rx testing)

Table 12-7: Test Settings — WP7603 LTE Transmission Path

Band		Frequency (MHz)	Band ID	Channel ^a
1900 MHz	B2	1880.0	43	18900
1700 MHz	B4	1732.4	42	20175
850 MHz	B5	836.5	45	20525
700 MHz	B12	707.5	50	23095

- a. Channel value used by the !DASCHAN command (!DASCHAN uses uplink (Tx) channel at the center of the corresponding band, for both Tx and Rx testing)

Table 12-8: Test Settings — WP7607 LTE Transmission Path

Band		Frequency (MHz)	Band ID	Channel ^a
2100 MHz	B1	1950.0	34	18300
1800 MHz	B3	1747.5	44	19575
2600 MHz	B7	2535.0	35	21100
900 MHz	B8	897.5	47	21625
800 MHz	B20	847.0	56	24300
700 MHz	B28	725.5	64	27435

- a. Channel value used by the !DASCHAN command (!DASCHAN uses uplink (Tx) channel at the center of the corresponding band, for both Tx and Rx testing)

Table 12-9: Test Settings — WP7608 LTE Transmission Path

Band		Frequency (MHz)	Band ID	Channel ^a
2100 MHz	B1	1950.0	34	18300
1800 MHz	B3	1747.5	44	19575
850 MHz	B5	836.5	45	20525
900 MHz	B8	897.5	47	21625
2300 MHz	B40	2350.0	92	39150
2500 MHz	B41	2593.0	76	40620

- a. Channel value used by the !DASCHAN command (!DASCHAN uses uplink (Tx) channel at the center of the corresponding band, for both Tx and Rx testing)

Table 12-10: Test Settings — WP7609 LTE Transmission Path

Band		Frequency (MHz)	Band ID	Channel ^a
2100 MHz	B1	1950.0	34	18300
1800 MHz	B3	1747.5	44	19575
850 MHz	B5	836.5	45	20525
2600 MHz	B7	2535.0	35	21100

Table 12-10: Test Settings — WP7609 LTE Transmission Path (Continued)

Band		Frequency (MHz)	Band ID	Channel ^a
900 MHz	B8	897.5	47	21625
700 MHz	B28	725.5	64	27435

a. Channel value used by the !DASCHAN command (!DASCHAN uses uplink (Tx) channel at the center of the corresponding band, for both Tx and Rx testing)

Table 12-11: Test Settings — WP7610 LTE Transmission Path

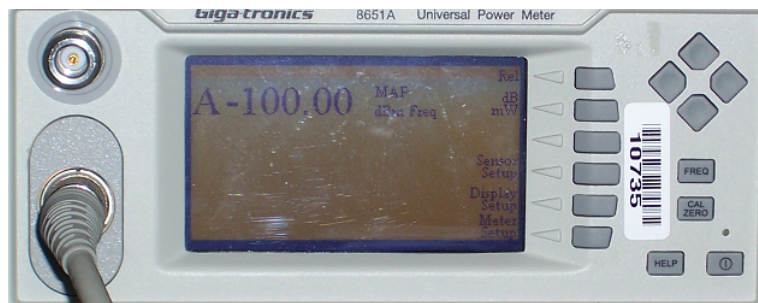
Band		Frequency (MHz)	Band ID	Channel ^a
1900 MHz	B2	1880.0	43	18900
1700 MHz	B4	1732.4	42	20175
850 MHz	B5	836.5	45	20525
700 MHz	B12	707.5	50	23095
700 MHz	B13	782.0	36	23230
700 MHz	B14	793.0	51	23330
700 MHz	B17	710.0	37	24290
1700 MHz	B66	1745.0	83	132322

a. Channel value used by the !DASCHAN command (!DASCHAN uses uplink (Tx) channel at the center of the corresponding band, for both Tx and Rx testing)

To test the DUT’s transmitter path:

Note: This procedure describes steps using the 'Power Meter: Gigatronics 8651A' (with Option 12 and Power Sensor 80701A).

1. Set up the power meter:



- a. Make sure the meter has been given sufficient time to warm up, if necessary, to enable it to take accurate measurements.
- b. Zero-calibrate the meter.
- c. Enable MAP mode.

-
2. Prepare the DUT using the following AT commands (adjusting the band, channel, bandwidth, modulation, RB allocation, NS, and power level as necessary):
 - a. **ATIENTERCND="<password>"** (Unlock extended AT command set.)
 - b. **ATIDAFTMACT** (Enter test mode.)
 - c. **ATIDASBAND=<bandValue>** (Set frequency band (e.g. 34 for LTE B1.)
 - See tables 12-6–12-10 for appropriate <bandValue> values.
 - d. **ATIDALSTXBW=3** (Set Tx bandwidth to 10 MHz.)
 - e. **ATIDALSRXBW=3** (Set Rx bandwidth to 10 MHz.)
 - f. **ATIDASCHAN=<channel>** (Set modem channel (e.g. 18300 for LTE B1.)
 - See tables 12-6–12-10 for appropriate <channel> values.
 - g. **ATIDALSTXMOD=0** (Set Tx modulation type to QPSK.)
 - h. **ATIDALSWAVEFORM=1,12,0,19** (Set the Tx waveform characteristics. Make sure to set the correct resource block allocation (2nd parameter) appropriately. For example, 12 is used to produce max power—refer to 3GPP 36.521 table for Maximum Power Reduction (MPR) for Power Class 3 for more information.)
 - i. **ATIDALSNSVAL=1** (Set the LTE NS (Net Sig) value.)
 - j. **ATIDASTXON** (Turn on the transmitter. Note that the transmitter will put out the last power level that was programmed.)
 - k. **ATIDALSTXPWR=1,10** (Begin transmitting at requested power level.)
 - l. Take the measurement.
 - m. Repeat [Step k](#) with different power levels if desired.
 - n. **ATIDALSTXPWR=0,0** (Reduce Tx power to 0, so next time transmitter is turned on, it will come on with 0 dBm power.)
 - o. **ATIDASTXOFF** (Turn off the transmitter.)
 3. Test limits — Run ten or more good DUTs through this test procedure to obtain a nominal output power value.
 - Apply a tolerance of ± 5 to 6 dB to each measurement (assuming a good setup design).
 - Monitor these limits during mass-production ramp-up to determine if further adjustments are needed.

Note: The module has a nominal output power of +23 dBm ± 1 dB in LTE mode. However, the value measured by the power meter is significantly influenced (beyond the stated ± 1 dB output power tolerance) by the test setup (host RF cabling loss, antenna efficiency and pattern, test antenna efficiency and pattern, and choice of shield box).

Note: When doing the same test over the air in an RF chamber, values are likely to be significantly lower.

12.6 UMTS (WCDMA / GSM) RF Receive Path Test

Note: This procedure segment is performed in [Step 14](#) of the [Production Test Procedure](#) on page 146.

The suggested test procedure that follows uses the parameters in the following tables.

Table 12-12: Test Settings — WP7603 UMTS Receive Path

Band		Frequency ^a (MHz)	Band ID	Channel ^b
1900 MHz	B2	1961.20	15 ^c	9400
1700 MHz	B4	2133.20	28	1412
850 MHz	B5	882.60	22	4182

- a. Receive frequencies shown are 1.2 MHz offset from center
- b. Channel value used by the !DASCHAN command (!DASCHAN uses uplink (Tx) channel at the center of the corresponding band, for both Tx and Rx testing)
- c. Either 15 (WCDMA1900A) or 16 (WCDMA1900B) may be used for testing.

Table 12-13: Test Settings — WP7607 / WP7608 UMTS Receive Path

Band		Frequency ^a (MHz)	Band ID	Rx Channel ^b
2100 MHz	B1	2141.2	9	9750
900 MHz	B8	943.8	29	2788

- a. Receive frequencies shown are 1.2 MHz offset from center
- b. Channel values shown are at the center of the corresponding bands.

Table 12-14: Test Settings — WP7609 UMTS Receive Path

Band		Frequency ^a (MHz)	Band ID	Rx Channel ^b
2100 MHz	B1	2141.2	9	9750
850 MHz	B5	882.6	22	4182
900 MHz	B8	943.8	29	2788

- a. Receive frequencies shown are 1.2 MHz offset from center
- b. Channel values shown are at the center of the corresponding bands.

Table 12-15: Test Settings — WP7610 UMTS Receive Path

Band		Frequency ^a (MHz)	Band ID	Channel ^b
1900 MHz	B2	1961.20	15 ^c	9400
1700 MHz	B4	2133.20	28	1412
850 MHz	B5	882.60	22	4182

- a. Receive frequencies shown are 1.2 MHz offset from center
- b. Channel value used by the !DASCHAN command (!DASCHAN uses uplink (Tx) channel at the center of the corresponding band, for both Tx and Rx testing)
- c. Either 15 (WCDMA1900A) or 16 (WCDMA1900B) may be used for testing.

Table 12-16: Test Settings — WP7607 / WP7608 / WP7609 2G Receive Path

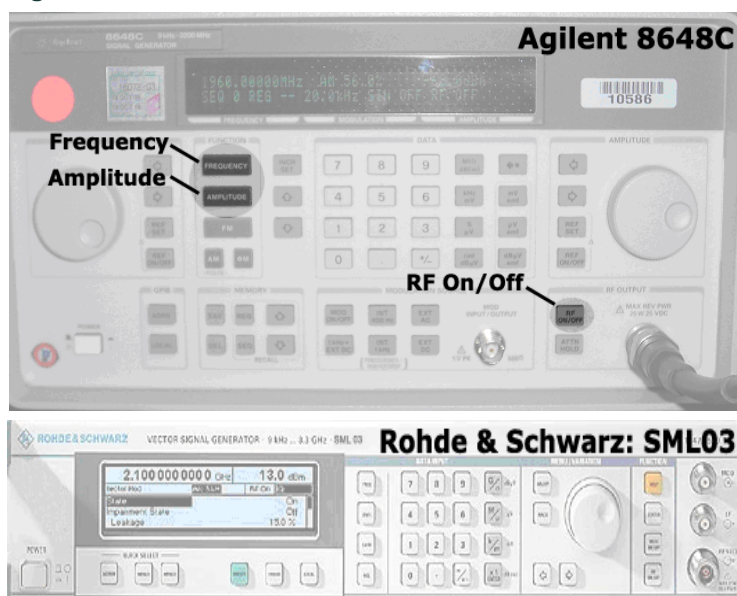
Band		Frequency ^a (MHz)	Band ID	Rx Channel ^b
900 MHz	E-GSM 900	942.467	10	37
1800 MHz	DCS 1800	1842.867	11	700

- Receive frequencies shown are 67 KHz offset from center
- Channel values shown are at the center of the corresponding bands.

To test the DUT's receive path:

Note: This procedure describes steps using the Agilent 8648C signal generator — the Rohde & Schwarz SML03 is shown for reference only.

- Set up the signal generator:



- Set the amplitude to:
 - 80 dBm (WCDMA mode)
 - 60 dBm (GSM mode)
 - Set the frequency for the band being tested. See tables 12-12–12-18 for frequency values.
- Set up the DUT:
 - ATIENTERCND=<password>** (Unlock extended AT command set.)
 - ATIDAFTMACT** (Put modem into factory test mode.)
 - ATIDASBAND=<band>** (Set frequency band.)
 - See tables 12-12–12-18 for <band> values
 - ATIDASCHAN=<channel>** (Set modem channel)
 - See tables 12-12–12-18 for <channel> values
 - ATIDASLNAGAIN=0** (Set the LNA to maximum gain.)

- f. (WCDMA mode)
ATIDAWGAVGAGC=9400,0 (For PCS1900, channel 9400 as an example.)
(GSM mode)

- i. **ATIDAGSRXBURST=0** (Set to receive bursted mode.)
ii. **ATIDAGGAVGRSSI=190,0** (For channel 190, for example)

The returned value is the RSSI in dBm.

3. Test limits — Run ten or more good DUTs through this test procedure to obtain a nominal received power value.
- Apply a tolerance of ± 5 to 6 dB to each measurement (assuming a good setup design).
 - Make sure the measurement is made at a high enough level that it is not influenced by DUT-generated and ambient noise.
 - The Signal Generator power level can be adjusted and new limits found if the radiated test needs greater signal strength.
 - Monitor these limits during mass-production ramp-up to determine if further adjustments are needed.

Note: The value measured from the DUT is significantly influenced by the test setup and DUT design (host RF cabling loss, antenna efficiency and pattern, test antenna efficiency and pattern, and choice of shield box).

4. Test diversity paths:
- a. Set up the signal generator as in [Step 1](#).

*Note: Setup of the DUT is the same as in [Step 2](#), except for a change to **ATIDAWGAVGAGC** and the addition of **ATIDAWSSCHAIN**.*

- b. Set up the DUT:
- i. **ATIENTERCND=<password>** (Unlock extended AT command set.)
ii. **ATIDAFTMACT** (Put modem into factory test mode.)
iii. **ATIDASBAND=<band>** (Set frequency band.)
• See tables [12-12–12-18](#) for <band> values
iv. **ATIDAWSSCHAIN=1** (Enable the secondary chain.)
v. **ATIDASCHAN=<channel>** (Set modem channel)
• See tables [12-12–12-18](#) for <channel> values
vi. **ATIDASLNAGAIN=0** (Set the LNA to maximum gain.)
vii. **ATIDAWGAVGAGC=9400,0,1** (The '1' indicates the diversity path is used.)
- c. Test the limits as in [Step 3](#).

12.7 LTE RF Receive Path Test

Note: This procedure segment is performed in [Step 14](#) of the [Production Test Procedure](#) on page 146.

The suggested test procedure that follows uses the parameters in the following tables.

Table 12-17: Test Settings — WP7601 LTE Receive Path

Band		Frequency ^a (MHz)	Band ID	Channel ^b
1700 MHz	B4	2134.50	42	20175
780 MHz	B13	753.00	36	23230

- Receive frequencies shown are 2 MHz offset from center
- Channel value used by the !DASCHAN command (!DASCHAN uses uplink (Tx) channel at the center of the corresponding band, for both Tx and Rx testing)

Table 12-18: Test Settings — WP7603 LTE Receive Path

Band		Frequency ^a (MHz)	Band ID	Channel ^b
1900 MHz	B2	1962.00	43	18900
1700 MHz	B4	2134.50	42	20175
850 MHz	B5	883.50	45	20525
700 MHz	B12	739.50	50	23095

- Receive frequencies shown are 2 MHz offset from center
- Channel value used by the !DASCHAN command (!DASCHAN uses uplink (Tx) channel at the center of the corresponding band, for both Tx and Rx testing)

Table 12-19: Test Settings — WP7607 LTE Receive Path

Band		Frequency ^a (MHz)	Band ID	Rx Channel ^b
2100 MHz	B1	2142.00	34	18300
1800 MHz	B3	1844.5	44	19575
2600 MHz	B7	2657.00	35	21100
900 MHz	B8	944.5	47	21625
800 MHz	B20	808.00	56	24300
700 MHz	B28	782.5	64	27435

- Receive frequencies shown are 2 MHz offset from center
- Channel values shown are at the center of the corresponding bands.

Table 12-20: Test Settings — WP7608 LTE Receive Path

Band		Frequency ^a (MHz)	Band ID	Rx Channel ^b
2100 MHz	B1	2142.00	34	18300
1800 MHz	B3	1844.5	44	19575

Table 12-20: Test Settings — WP7608 LTE Receive Path (Continued)

Band		Frequency ^a (MHz)	Band ID	Rx Channel ^b
850 MHz	B5	883.50	45	20525
900 MHz	B8	944.5	47	21625
2300 MHz	B40	2352.0	92	39150
2500 MHz	B41	2595.0	76	40620

- a. Receive frequencies shown are 2 MHz offset from center
- b. Channel values shown are at the center of the corresponding bands.

Table 12-21: Test Settings — WP7609 LTE Receive Path

Band		Frequency ^a (MHz)	Band ID	Rx Channel ^b
2100 MHz	B1	2142.00	34	18300
1800 MHz	B3	1844.5	44	19575
850 MHz	B5	883.50	45	20525
2600 MHz	B7	2657.00	35	21100
900 MHz	B8	944.5	47	21625
700 MHz	B28	782.5	64	27435

- a. Receive frequencies shown are 2 MHz offset from center
- b. Channel values shown are at the center of the corresponding bands.

Table 12-22: Test Settings — WP7610 LTE Receive Path

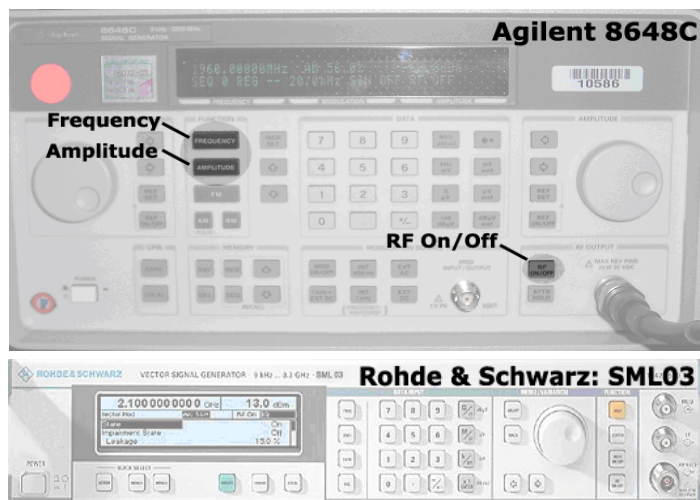
Band		Frequency ^a (MHz)	Band ID	Channel ^b
1900 MHz	B2	1962.00	43	18900
1700 MHz	B4	2134.50	42	20175
850 MHz	B5	883.50	45	20525
700 MHz	B12	739.50	50	23095
780 MHz	B13	753.00	36	23230
700 MHz	B14	765.0	51	23330
700 MHz	B17	742.0	37	23790
1700 MHz	B66	2147.0	83	132322

- a. Receive frequencies shown are 2 MHz offset from center
- b. Channel value used by the !DASCHAN command (!DASCHAN uses uplink (Tx) channel at the center of the corresponding band, for both Tx and Rx testing)

To test the DUT's receive path (or diversity path, while connected to the diversity antenna):

Note: This procedure describes steps using the Agilent 8648C signal generator—the Rohde & Schwarz SML03 is shown for reference only.

1. Set up the signal generator:



- a. Set the amplitude to -70 dBm
 - b. Set the frequency for the band being tested. See tables 12-17–12-21 for frequency values.
2. Set up the DUT:
 - a. **ATIENTERCND=<password>** (Unlock extended AT command set.)
 - b. **ATIDAFTMACT** (Put modem into factory test mode.)
 - c. **ATIDASBAND=<band>** (Set frequency band.)
 - See tables 12-17–12-21 for <band> values
 - d. **ATIDALSRXBW=2** (Set Rx LTE bandwidth to 5MHz.)
 - e. **ATIDALSTXBW=2** (Set Tx LTE bandwidth to 5MHz.)
 - f. **ATIDASCHAN=<channel>** (Set modem channel)
 - See tables 12-17–12-21 for <channel> values
 - g. **ATIDALGAVGAGC=<channel>,0** (Get averaged Rx AGC)
 - See tables 12-17–12-21 for <channel> values
 3. Test limits—Run ten or more good DUTs through this test procedure to obtain a nominal received power value.
 - Apply a tolerance of ± 5 to 6 dB to each measurement (assuming a good setup design).
 - Make sure the measurement is made at a high enough level that it is not influenced by DUT-generated and ambient noise.
 - The Signal Generator power level can be adjusted and new limits found if the radiated test needs greater signal strength.
 - Monitor these limits during mass-production ramp-up to determine if further adjustments are needed.

Note: The value measured from the DUT is significantly influenced by the test setup and DUT design (host RF cabling loss, antenna efficiency and pattern, test antenna efficiency and pattern, and choice of shield box).

12.8 GNSS RF Receive Path Test

The GNSS receive path uses the dedicated GNSS connector.

To test the GNSS receive path:

1. Inject a carrier signal at -110dBm, frequency 1575.52 MHz into the GNSS Rx path at the connector. (Note that this frequency is 100 kHz higher than the actual GPS L1 center frequency.)
2. Test the signal carrier-to-noise level at the GNSS receiver:
 - a. **ATIENTERCND=<password>** (Unlock extended AT command set.)
 - b. **ATIDAFTMACT** (Put modem into factory test mode.)
 - c. **ATIDACGPSTESTMODE=1** (Start CGPS diagnostic task.)
 - d. **ATIDACGPSSTANDALONE=1** (Enter standalone RF mode.)
 - e. **ATIDACGPSMASKON** (Enable log mask.)
 - f. **ATIDACGPSCTON** (Return signal-to-noise and frequency measurements.)
 - g. Repeat **ATIDACGPSCTON** five to ten times to ensure the measurements are repeatable and stable.
3. Leave the RF connection to the embedded module intact, and turn off the signal generator.
4. Take several more **IDACGPSCTON** readings. This will demonstrate a 'bad' signal in order to set limits for testing, if needed. This frequency offset should fall outside of the guidelines in the note below, which indicates that the CtoN result is invalid.
5. (Optional) Turn the signal generator on again, and reduce the level to -120dBm. Take more **IDACGPSCTON** readings and use these as a reference for what a marginal / poor signal would be.

*Note: The response to **ATIDACGPSCTON** for a good connection should show CtoN within 58 +/- 5dB and Freq (frequency offset) within 100000 Hz +/- 5000 Hz.*

A: Appendix

A.1 Website Support

Check <http://source.sierrawireless.com/> for the latest documentation available.

A.2 Reference Documents

- AirPrime WP8548/WP75xx / WP76xx/WP77xx AT Command Reference
Reference number: 4118047
- Inter-Chip USB Supplement to the USB 2.0 Specification Revision 1.0
Legato.io for Legato API details
- AirPrime WPx5 / WP76 Series Customer Process Guidelines
Reference number: 4116612
- AirPrime WPx5xx / WP76xx Scalability Guide
Reference number: 41110866
- I2C Bus Specification, Version 2.1, January 2000
Reference: Phillips Semiconductor document number 9398 393 40011

A.3 Abbreviations

Table A-1: Acronyms and Definitions

Acronym or Term	Definition
3GPP	3rd Generation Partnership Project
8PSK	Octagonal Phase Shift Keying
ADC	Analog to Digital Converter
AF	Audio-Frequency
API	Application Programming Interface
AT	Attention (prefix for modem commands)
BeiDou	BeiDou Navigation Satellite System A Chinese system that uses a series of satellites in geostationary and middle earth orbits to provide navigational data.
BER	Bit Error Rate — A measure of receive sensitivity
BLER	Block Error Rate
Bluetooth	Wireless protocol for data exchange over short distances
CEP CEP-###	Circular Error Probability — Measure of GPS horizontal accuracy indicating the radius of a circle around the actual position that contains 50% of GPS measurements. CEP-### — Radius of circle containing ###% of GPS measurements (e.g. CEP-90 indicates 90% of measurements contained within circle)
CF3	Common Flexible Form Factor

Table A-1: Acronyms and Definitions (Continued)

Acronym or Term	Definition
CLK	Clock
CMOS	Complementary Metal Oxide Semiconductor
CPU	Central Processing Unit
CQI	Channel Quality Indication
CS	Circuit-Switched
	Coding Scheme
CTS	Clear To Send
CW	Continuous waveform
DAC	Digital to Analog Converter
dB	Decibel = $10 \times \log_{10}(P1/P2)$ <i>P1 is calculated power; P2 is reference power</i> Decibel = $20 \times \log_{10}(V1/V2)$ <i>V1 is calculated voltage, V2 is reference voltage</i>
dBm	A logarithmic (base 10) measure of relative power (dB for decibels); relative to milliwatts (m). A dBm value will be 30 units (1000 times) larger (less negative) than a dBW value, because of the difference in scale (milliwatts vs. watts).
DC	Direct Current
DCD	Data Carrier Detect
DCS	Digital Cellular System A cellular communication infrastructure that uses the 1.8 GHz radio spectrum.
DL	Downlink (network to mobile)
DRX	Discontinuous Reception
DSR	Data Set Ready
DTR	Data Terminal Ready
E-GSM	Extended GSM
EDGE	Enhance Data rates for GSM Evolution
EFR	Enhanced Full Rate
EGPRS	Enhance GPRS
EIRP	Effective (or Equivalent) Isotropic Radiated Power
EMC	Electromagnetic Compatibility
EN	Enable
ERP	Effective Radiated Power
ESD	Electrostatic Discharges

Table A-1: Acronyms and Definitions (Continued)

Acronym or Term	Definition
eSIM	Embedded SIM
ETSI	European Telecommunications Standards Institute
FCC	Federal Communications Commission The U.S. federal agency that is responsible for interstate and foreign communications. The FCC regulates commercial and private radio spectrum management, sets rates for communications services, determines standards for equipment, and controls broadcast licensing. Consult www.fcc.gov .
FDD	Frequency Division Duplex
FDMA	Frequency Division Multiple Access
firmware	Software stored in ROM or EEPROM; essential programs that remain even when the system is turned off. Firmware is easier to change than hardware but more permanent than software stored on disk.
FOV	Field Of View
FR	Full Rate
FSN	Factory Serial Number—A unique serial number assigned to the module during manufacturing.
Galileo	A European system that uses a series of satellites in middle earth orbit to provide navigational data.
GCF	Global Certification Forum
GLONASS	Global Navigation Satellite System — A Russian system that uses a series of 24 satellites in middle circular orbit to provide navigational data.
GMSK	Gaussian Minimum Shift Keying modulation
GND	Ground
GNSS	Global Navigation Satellite Systems (GPS, GLONASS, BeiDou, and Galileo)
GPIO	General Purpose Input Output
GPRS	General Packet Radio Service
GPS	Global Positioning System An American system that uses a series of 24 satellites in middle circular orbit to provide navigational data.
GSM	Global System for Mobile communications
Hi Z	High impedance (Z)
Host	The device into which an embedded module is integrated
HR	Half Rate
HSDPA	High Speed Downlink Packet Access
HSUPA	High Speed Uplink Packet Access
Hz	Hertz = 1 cycle/second

Table A-1: Acronyms and Definitions (Continued)

Acronym or Term	Definition
I/O	Input/Output
IC	Industry Canada
IC	Integrated Circuit
IMEI	International Mobile Equipment Identity
IMS	IP Multimedia Subsystem — Architectural framework for delivering IP multimedia services.
inrush current	Peak current drawn when a device is connected or powered on
IOT	Interoperability Testing
IS	Interim Standard. After receiving industry consensus, the TIA forwards the standard to ANSI for approval.
ISIM	IMS Subscriber Identity Module.
LED	Light Emitting Diode. A semiconductor diode that emits visible or infrared light.
LGA	Land Grid Array
LHCP	Left-Hand Circular Polarized
LNA	Low noise Amplifier
LTE	Long Term Evolution—a high-performance air interface for cellular mobile communication systems.
MAX	Maximum
MCS	Modulation and Coding Scheme
MHz	Megahertz = 10e6 Hz
MIC	Microphone
MIMO	Multiple Input Multiple Output—wireless antenna technology that uses multiple antennas at both transmitter and receiver side. This improves performance.
MIN	Minimum
MO	Mobile Originated
MT	Mobile Terminated
N/A	Not Applicable
NMEA	National Marine Electronics Association
NOM	Nominal
OEM	Original Equipment Manufacturer—a company that manufactures a product and sells it to a reseller.
PA	Power Amplifier

Table A-1: Acronyms and Definitions (Continued)

Acronym or Term	Definition
packet	A short, fixed-length block of data, including a header, that is transmitted as a unit in a communications network.
PBCCH	Packet Broadcast Control Channel
PC	Personal Computer
PCB	Printed Circuit Board
PCL	Power Control Level
PCS	Personal Communication System A cellular communication infrastructure that uses the 1.9 GHz radio spectrum.
PDN	Packet Data Network
PFM	Power Frequency Modulation
PLL	Phase Lock Loop
PMIC	Power Management Integrated Circuit
PSM	Power Saving Mode
PSS	Primary synchronization signal
PST	Product Support Tools
PTCRB	PCS Type Certification Review Board
PWM	Pulse Width Modulation
QAM	Quadrature Amplitude Modulation. This form of modulation uses amplitude, frequency, and phase to transfer data on the carrier wave.
QPSK	Quadrature Phase-Shift Keying
QZSS	Quasi-Zenith Satellite System
R2C	Ready-To-Connect
RAM	Random Access Memory
RAT	Radio Access Technology
RF	Radio Frequency
RHCP	Right Hand Circular Polarization
RI	Ring Indicator
RSE	Radiated Spurious Emissions
RSSI	Received Signal Strength Indication
RST	Reset
RTC	Real Time Clock
RTS	Request To Send

Table A-1: Acronyms and Definitions (Continued)

Acronym or Term	Definition
RX	Receive
SCLK	Serial Clock
SDC	Secure digital controller
SED	Smart Error Detection
Sensitivity (Audio)	Measure of lowest power signal that the receiver can measure.
Sensitivity (RF)	Measure of lowest power signal at the receiver input that can provide a prescribed BER/BLER/SNR value at the receiver output.
SIM	Subscriber Identity Module.
SIMO	Single Input Multiple Output—Wireless antenna technology that uses multiple antennas at the receiver side and one antenna at the source (transmitter).
SKU	Stock Keeping Unit—identifies an inventory item: a unique code, consisting of numbers or letters and numbers, assigned to a product by a retailer for purposes of identification and inventory control.
SMS	Short Message Service
SNR	Signal-to-Noise Ratio
SPI	Serial Peripheral Interface
SPK	Speaker
SW	Software
TBC	To Be Confirmed
TBD	To Be Determined
TDD	Time Division Duplex
TIA/EIA	Telecommunications Industry Association / Electronics Industry Association. A standards setting trade organization, whose members provide communications and information technology products, systems, distribution services and professional services in the United States and around the world. Consult www.tiaonline.org .
TIS	Total Isotropic Sensitivity
TP	Test Point
TRP	Total Radiated Power
TX	Transmit
TYP	Typical
UART	Universal Asynchronous Receiver-Transmitter
UE	User Equipment
UICC	Universal Integrated Circuit Card
UIM	User Identity Module. Generic term used in this document to refer to UICC, where the application on the UICC (USIM, ISIM, CSIM, etc.) varies depending on the provider of the card.

Table A-1: Acronyms and Definitions (Continued)

Acronym or Term	Definition
UL	Uplink (mobile to network)
UMTS	Universal Mobile Telecommunications System
USB	Universal Serial Bus
USB-SS	USB Selective Suspend/USB not enumerated
USIM	Universal Subscriber Identity Module (UMTS)
USSD	Unstructured Supplementary Services Data
UTRA	UMTS Terrestrial Radio Access
VBAT-BB	Baseband power supply
VBAT-RF	RF power supply
VCC	Supply voltage
VSWR	Voltage Standing Wave Ratio
WCDMA	Wideband Code Division Multiple Access (also referred to as UMTS)
WLAN	Wireless Local Area Network
WWAN	Wireless Wide Area Network
ZIF	Zero Intermediate Frequency