



# AirPrime XM Series

## Customer Process Guidelines



**SIERRA**  
WIRELESS®

41112796  
1.0  
December 11, 2018

## Important Notice

Due to the nature of wireless communications, transmission and reception of data can never be guaranteed. Data may be delayed, corrupted (i.e., have errors) or be totally lost. Although significant delays or losses of data are rare when wireless devices such as the Sierra Wireless modem are used in a normal manner with a well-constructed network, the Sierra Wireless modem should not be used in situations where failure to transmit or receive data could result in damage of any kind to the user or any other party, including but not limited to personal injury, death, or loss of property. Sierra Wireless accepts no responsibility for damages of any kind resulting from delays or errors in data transmitted or received using the Sierra Wireless modem, or for failure of the Sierra Wireless modem to transmit or receive such data.

## Safety and Hazards

Do not operate the Sierra Wireless modem in areas where cellular modems are not advised without proper device certifications. These areas include environments where cellular radio can interfere such as explosive atmospheres, medical equipment, or any other equipment which may be susceptible to any form of radio interference. The Sierra Wireless modem can transmit signals that could interfere with this equipment. Do not operate the Sierra Wireless modem in any aircraft, whether the aircraft is on the ground or in flight. In aircraft, the Sierra Wireless modem **MUST BE POWERED OFF**. When operating, the Sierra Wireless modem can transmit signals that could interfere with various onboard systems.

---

*Note: Some airlines may permit the use of cellular phones while the aircraft is on the ground and the door is open. Sierra Wireless modems may be used at this time.*

---

The driver or operator of any vehicle should not operate the Sierra Wireless modem while in control of a vehicle. Doing so will detract from the driver or operator's control and operation of that vehicle. In some states and provinces, operating such communications devices while in control of a vehicle is an offence.

## Limitations of Liability

This manual is provided "as is". Sierra Wireless makes no warranties of any kind, either expressed or implied, including any implied warranties of merchantability, fitness for a particular purpose, or noninfringement. The recipient of the manual shall endorse all risks arising from its use.

The information in this manual is subject to change without notice and does not represent a commitment on the part of Sierra Wireless. SIERRA WIRELESS AND ITS AFFILIATES SPECIFICALLY DISCLAIM LIABILITY FOR ANY AND ALL DIRECT, INDIRECT, SPECIAL, GENERAL, INCIDENTAL, CONSEQUENTIAL, PUNITIVE OR EXEMPLARY DAMAGES INCLUDING, BUT NOT LIMITED TO, LOSS OF PROFITS OR REVENUE OR ANTICIPATED PROFITS OR REVENUE ARISING OUT OF THE USE OR INABILITY TO USE ANY SIERRA WIRELESS PRODUCT, EVEN IF SIERRA WIRELESS AND/OR ITS AFFILIATES HAS BEEN ADVISED OF THE POSSIBILITY OF SUCH DAMAGES OR THEY ARE FORESEEABLE OR FOR CLAIMS BY ANY THIRD PARTY.

Notwithstanding the foregoing, in no event shall Sierra Wireless and/or its affiliates aggregate liability arising under or in connection with the Sierra Wireless product, regardless of the number of events, occurrences, or claims giving rise to liability, be in excess of the price paid by the purchaser for the Sierra Wireless product.

## Patents

This product may contain technology developed by or for Sierra Wireless Inc.

This product includes technology licensed from QUALCOMM®.

This product is manufactured or sold by Sierra Wireless Inc. or its affiliates under one or more patents licensed from MMP Portfolio Licensing.

## Copyright

© 2018 Sierra Wireless. All rights reserved.

## Trademarks

Sierra Wireless®, AirPrime®, AirLink®, AirVantage®, WISMO®, ALEOS® and the Sierra Wireless and Open AT logos are registered trademarks of Sierra Wireless, Inc. or one of its subsidiaries.

Watcher® is a registered trademark of NETGEAR, Inc., used under license.

Windows® and Windows Vista® are registered trademarks of Microsoft Corporation.

Macintosh® and Mac OS X® are registered trademarks of Apple Inc., registered in the U.S. and other countries.

QUALCOMM® is a registered trademark of QUALCOMM Incorporated. Used under license.

Other trademarks are the property of their respective owners.

## Contact Information

Sales information and technical support, including warranty and returns	Web: <a href="http://sierrawireless.com/company/contact-us/">sierrawireless.com/company/contact-us/</a> Global toll-free number: 1-877-687-7795 6:00 am to 5:00 pm PST
Corporate and product information	Web: <a href="http://sierrawireless.com">sierrawireless.com</a>

# Document History

Version	Date	Updates
1.0	December 11, 2018	Creation

# >> Contents

<b>1. INTRODUCTION .....</b>	<b>8</b>
1.1. Overview .....	8
1.2. Reference Documents .....	8
<b>2. HANDLING .....</b>	<b>9</b>
2.1. Storage and Handling .....	9
2.1.1. Storage Condition .....	9
2.1.2. ESD .....	9
2.1.3. Moisture Sensitivity .....	9
2.2. Component Package .....	10
2.2.1. Package Description .....	10
2.2.2. Marking Description .....	10
2.3. Component Packing .....	11
2.3.1. Packing Description .....	11
2.3.2. Packing Label .....	12
<b>3. SMT ASSEMBLY PROCESS .....</b>	<b>13</b>
3.1. Lead-Free Process .....	13
3.2. PCB Design Requirements .....	14
3.2.1. PCB Surface Finish .....	14
3.2.2. Footprint .....	14
3.2.3. Layout Recommendations .....	14
3.3. Solder Mask .....	15
<b>4. BOARD MOUNTING GUIDELINES .....</b>	<b>16</b>
4.1. Stencil Design .....	16
4.2. Solder Reflow Profile .....	16
4.3. Washing and Potting .....	17
<b>5. REWORK GUIDELINES .....</b>	<b>18</b>
5.1. Retouch .....	18
5.2. Rework .....	18
5.2.1. Use of Hot Air Gun and Solder Iron .....	18
5.2.1.1. Component Removal .....	18
5.2.1.2. Pad Redress .....	18
5.2.1.3. Resoldering the XM Module .....	19
5.2.2. Use of Rework Machine .....	19
5.2.2.1. Component Removal .....	19
5.2.2.2. Pad Redress .....	19
5.2.2.3. Solder Paste Deposit .....	19
5.2.2.4. New Component Placement .....	19
5.2.2.5. New Component Soldering .....	19

**6. STORAGE AND FLOOR LIFE GUIDELINES .....20**

6.1. Moisture Color Coded Card and Caution Label .....20

6.2. Conditions for Baking .....21

6.3. Baking.....21



# List of Figures

Figure 1.	Marking Example.....	10
Figure 2.	Tape and Reel .....	11
Figure 3.	Pin 1 Location.....	11
Figure 4.	Reel/Box Label .....	12
Figure 5.	Carton Label.....	12
Figure 6.	Recommended Footprint – Copper Layout .....	14
Figure 7.	Recommended Solder Mask .....	15
Figure 8.	Recommended Paste Mask Layout .....	16
Figure 9.	Recommended Reflow Profile.....	17
Figure 10.	Humidity Indicator Card (HIC) Example .....	20
Figure 11.	Moisture Caution Label .....	20

# 1. Introduction

## 1.1. Overview

This document presents guidelines for the industrial assembly of an AirPrime XM Embedded Module on an application.

## 1.2. Reference Documents

- [1] AirPrime XM1100 Product Technical Specification  
Reference number: 41111067
- [2] AirPrime XM1110 Product Technical Specification  
Reference number: 41111059
- [3] AirPrime XM1210 Product Technical Specification  
Reference number: 41112759
- [4] JEDEC standard JESD625, Requirements for Handling Electrostatic Discharge – Sensitive (ESDS) Devices
- [5] ANSI/ESD S20.20: Protection of Electrical and Electronics Parts, Assemblies and Equipment
- [1] IPC/JEDEC J-STD-033 – Handling, Packing, Shipping and Use of Moisture / Reflow Sensitive Surface Mount Devices

## >> | 2. Handling

### 2.1. Storage and Handling

#### 2.1.1. Storage Condition

AirPrime XM modules must be stored in the following manner:

- In their sealed, original packages
- Up to 1 year
- Temperature  $\leq 40^{\circ}\text{C}$ ; RH  $\leq 90\%$ .

---

**Tip:** *For optimal results, the recommended storage temperature is  $+20^{\circ}\text{C} \pm 10$  degrees, below 60% RH.*

---

#### 2.1.2. ESD

The AirPrime XM module is ESD sensitive. For ESD level information, refer to the corresponding Product Technical Specification of each product as listed in section 1.2 Reference Documents.

It is recommended to use standard ESD precautions, as described in the following standards:

- JEDEC standard JESD625, Requirements for Handling Electrostatic Discharge-Sensitive (ESDS) Devices
- ANSI/ESD S20.20: Protection of Electrical and Electronics Parts, Assemblies and Equipment

#### 2.1.3. Moisture Sensitivity

The AirPrime XM is sensitive to moisture absorption:

- XM1210 is MSL3
- XM111x series is MSL4
- $245^{\circ}\text{C}$ , 2 reflows allowed on customer PCB; see additional details in section 4.2 Solder Reflow Profile.

---

**Caution:** *For MSL3 products, if the tape & reel vacuum pack is open for more than 168h, material should be baked at  $40^{\circ}\text{C}$  for 13 days. If parts are on tray, baking conditions are 9 hours at  $125^{\circ}\text{C}$ .*

*For MSL4 products, if the tape & reel vacuum pack is open for more than 72h, material should be baked at  $40^{\circ}\text{C}$  for 15 days. If parts are on tray, baking conditions are 11 hours at  $125^{\circ}\text{C}$ .*

---

It is recommended to follow the standard MSL procedure, as described in IPC/JEDEC J-STD-033 - Handling, Packing, Shipping and Use of Moisture / Reflow Sensitive Surface Mount Devices.

## 2.2. Component Package

### 2.2.1. Package Description

The AirPrime XM is a scalable QFN (quad flat no lead) package with 20 terminals.

Module thickness is 2.1 mm.

The PCB material is FR4. Plating gold.

For additional information, refer to the corresponding Product Technical Specification of each product as listed in section 1.2 Reference Documents.

### 2.2.2. Marking Description

Marking contents on the module may differ between each variant of the product family.

Common marking content includes:

- Model name
- FSN barcode
- Pin 1 indicator
- Country of fabrication

The example below is not contractual and do not show exact contents of the label. Label contents may also be rearranged to fit any additional customer-specific need or market segment and can change without notice at the sole discretion of Sierra Wireless.

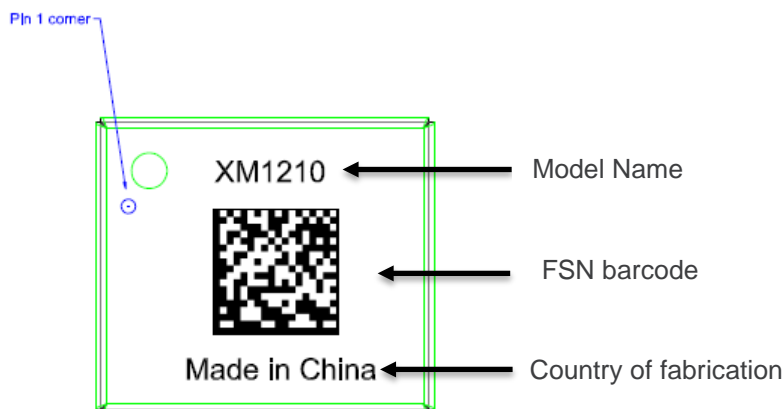

Figure 1. Marking Example

## 2.3. Component Packing

### 2.3.1. Packing Description

The AirPrime XM is delivered in tape and reel.

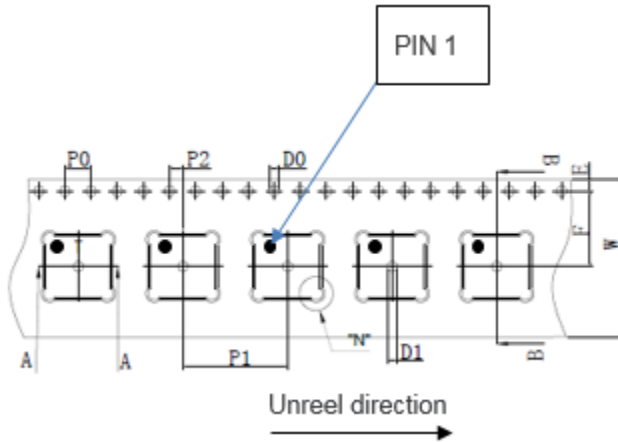

Figure 2. Tape and Reel

Product	Quantity per Tape and Reel	P1	P0	W
XM1210, XM1110, XM1100	1500	16.0 mm	4.0 mm	24.0 mm

Pin 1 corner is defined in the carrier tape, as shown in the figure below.



Figure 3. Pin 1 Location

### 2.3.2. Packing Label

Marking contents on the labels may differ between each variant of the product family.

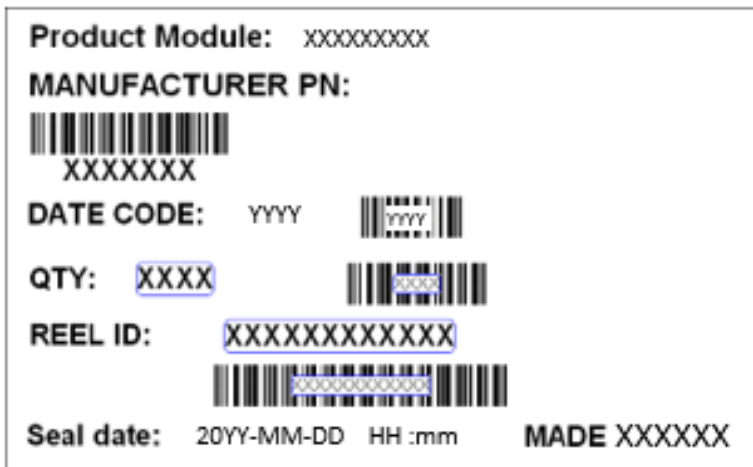

Figure 4. Reel/Box Label

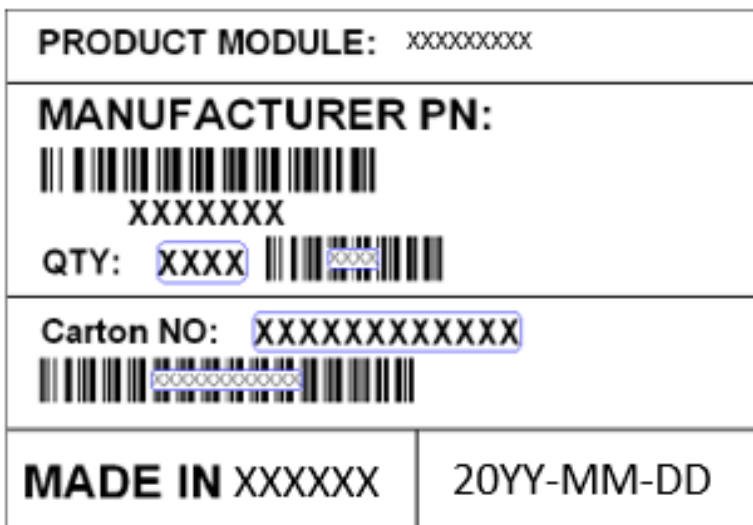

Figure 5. Carton Label

## >> 3. SMT Assembly Process

This section presents information and recommendations for the industrial assembly of the module on the application.

---

*Note: The module should be assembled by reflow process.*

---

The suggested footprint is compatible with XM11xx and XM12xx series and allow placement on the same layout as XA and XM series footprints.

### 3.1. Lead-Free Process

In compliance with directive 2011/65/CE and its amendments, Sierra Wireless products do not contain the following hazardous substances, unless with valid exemptions.

**Table 1. Restricted Substances**

<b>Substance Name</b>	<b>Limit (%)</b>
Lead	0.1%
Mercury	0.1%
Cadmium	0.01%
Hexavalent chromium	0.1%
Polybrominated biphenyls (PBB)	0.1%
Polybrominated diphenyl ethers (PBDE)	0.1%
Bis(2-ethylhexyl) phthalate (DEHP)	0.1%
Butyl benzyl phthalate (BBP)	0.1%
Dibutyl phthalate (DBP)	0.1%
Diisobutyl phthalate (DIBP)	0.1%

The AirPrime XM Series modules are manufactured with RoHS-compliant components and processes.

## 3.2. PCB Design Requirements

### 3.2.1. PCB Surface Finish

The PCB surface finish recommended is Electroless Nickel, immersion Gold. Organic Solderability Preservative (OSP) may also be used.

**Caution:** *Hot Air Solder Leveled finish (HASL) is not recommended because the process does not give consistent solder volumes on each pad because of poor pad flatness.*

### 3.2.2. Footprint

To produce high assembly yields and a reliable solder joint, the footprint on the customer application board should match Figure 6 below.

Note that manufacturing tolerance for copper pads is 30  $\mu\text{m}$ .

Mechanical drawings of the AirPrime XM footprint (including dimensions and pitch) are available in the Product Technical Specification of each product as listed in section 1.2 Reference Documents.

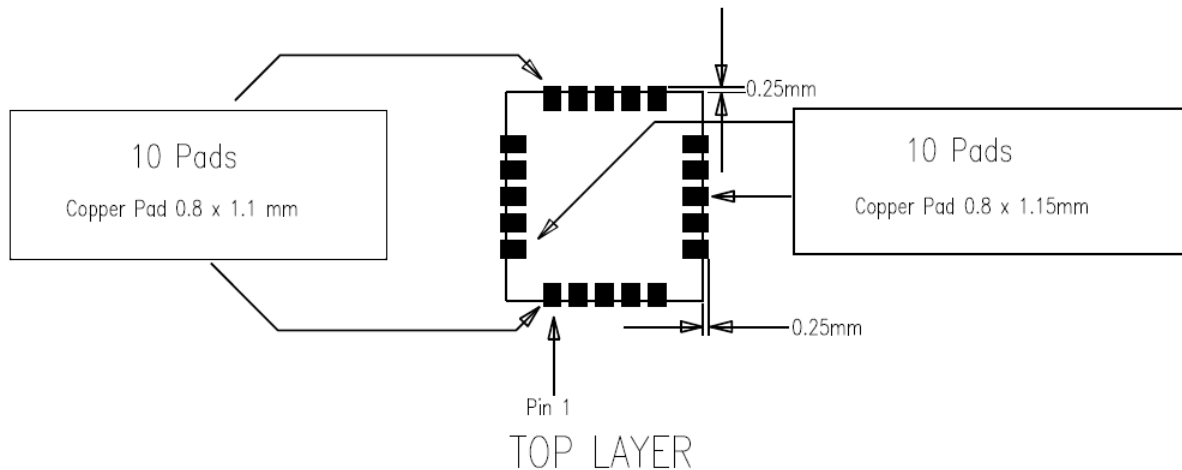

Figure 6. Recommended Footprint – Copper Layout

### 3.2.3. Layout Recommendations

Sierra Wireless' layout recommendations include:

- There should not be any SIGNAL trace or hole / micro-via under the AirPrime XM module.
- The antenna pad and its track should be adapted according to RF constraints, based on customer layout. Refer to each corresponding Product Technical Specification for more details.
- Leave a component-free area of 1 mm around the XM module for accessing the surrounding components.

### 3.3. Solder Mask

The pads on the printed circuit board are either Solder Mask Defined (SMD) or Non-Solder Mask Defined (NSMD).

Since the copper etching process has tighter control than solder masking process, NSMD pads are preferred over SMD pads.

Moreover, NSMD pads with solder mask opening larger than the metal pad size also improve the reliability of solder joints, as this limits the stress concentration at the solder-to mask corner interface.

For external pads, the solder mask opening should be 100  $\mu\text{m}$  to 150  $\mu\text{m}$  larger than the pad, resulting in 50  $\mu\text{m}$  to 75  $\mu\text{m}$  clearance between the copper pad and solder mask. This allows for solder mask registration tolerances, depending upon the PCB fabricator's capabilities.

The recommended solder mask thickness on the top copper is 10  $\mu\text{m}$  to 30  $\mu\text{m}$ .

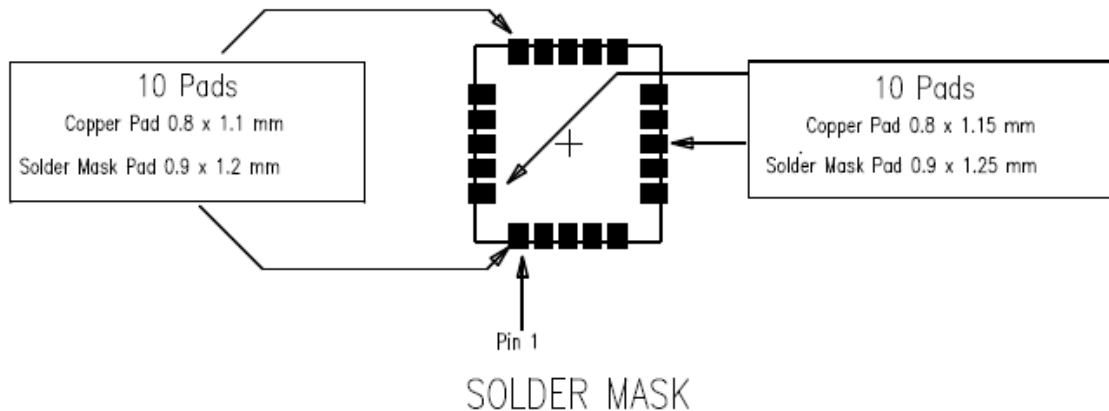

Figure 7. Recommended Solder Mask

## 4. Board Mounting Guidelines

The polarity mark is indicated by a “1” on the bottom side of the module.

### 4.1. Stencil Design

The recommended stencil thickness is 100 µm to 125 µm.

The proposed stencil design is presented in the figure below.

It is highly recommended to monitor the solder paste height, registration and proper placement during the squeegee printing.

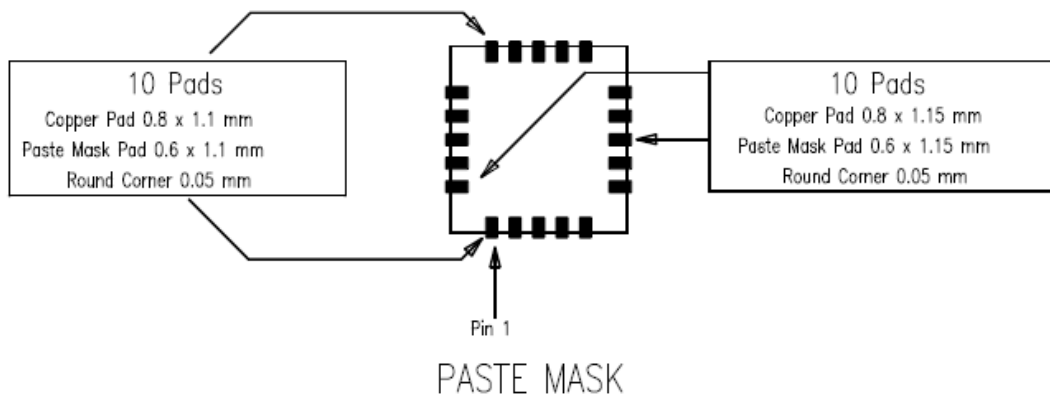

Figure 8. Recommended Paste Mask Layout

### 4.2. Solder Reflow Profile

Lead-free SMT reflow profiles should be used to surface mount the AirPrime XM module.

The reflow profile depends on PCB density and type of solder paste being used. The paste manufacturer’s recommendation should also be considered to determine the proper reflow profile.

The solder reflow profile specified in Table 2 is a mandatory requirement to ensure reliable assembly.

Table 2. Solder Reflow Profile

<b>Peak Temperature</b>	245°C max
<b>Number of reflow cycles</b>	2

**Caution:** *It is recommended to use only one reflow cycle for module assembly.*

If repairs or other rework are performed on the customer board near the XM module, care must be taken to ensure the module is not reflowed.

The figure below is a reflow profile example.

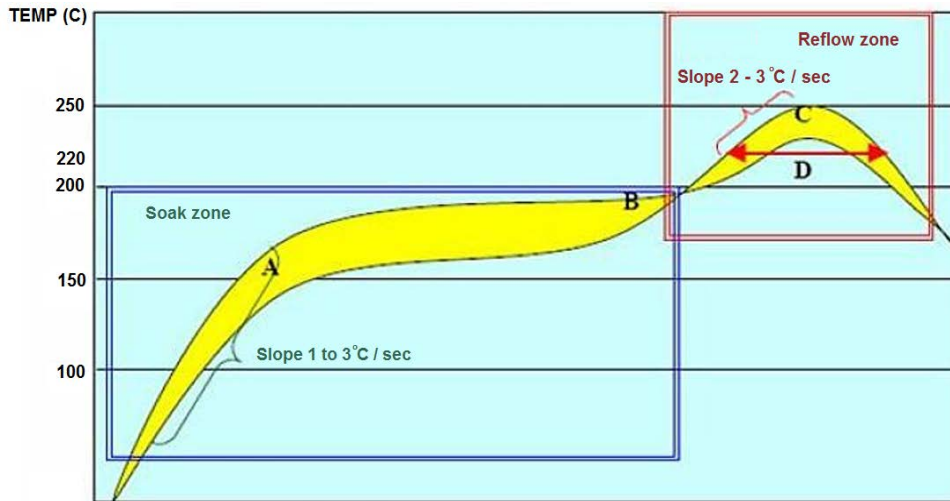

Figure 9. Recommended Reflow Profile

Additional recommendations are presented in the table below for consideration.

Factor	Recommendation
Slope at soak time	1 to 3°C / sec
Slope at reflow zone	2 to 3°C / sec
Soak time (between A and B: 150 and 190°C)	60 to 120 sec
Reflow time (D: over 220°C)	40 to 60 sec
Max temperature (C)	235 – 245°C
Slope at cooling down time	1 to 3°C / sec

*Note: It is recommended to perform reflow in a nitrogen atmosphere.*

### 4.3. Washing and Potting

Water wash is not recommended with shielded Sierra Wireless embedded modules due to difficulty in ensuring proper drying under the shield.

Use of ultrasonic process should be avoided as it can damage the quartz crystal components.

Sierra Wireless has not performed potting qualification tests on the XM module. Customers should pay attention to RF tracks since the  $\epsilon_{air}$  (epsilon-air) will be different below the potting compared to an open-air design. After potting a module, RF performance should be re-checked to guarantee that no degradation compared to nominal values occurred.

## >> 5. Rework Guidelines

Rework tools and operating parameters are customer/application specific. Rework tools, heating profiles and the rework process should be tailored to these specific needs for optimum results.

Prior to any rework, if the component floor life has been exceeded, it is highly recommended to bake the PCB to remove moisture from the assembly. (See JEDEC J-STD-033 paragraph 6 - Board rework. If possible for the PCB and the other components of the board, apply the same baking conditions as per section 2.1.3).

The pre-baking process will prevent damage to any component due to moisture vapor pressures caused during reflow.

Prior to removal, the metal shielding of the module must be glued to the module substrate by using glue able to withstand reflow profile.

### 5.1. Retouch

Retouch is done by:

- using a hot air gun preheated to  $380 \pm 20^{\circ}\text{C}$  for 10 to 20s, and
- using a solder iron for touch-ups.

Maximum heater temperature:  $385^{\circ}\text{C}$

Recommended contact time: 10 sec maximum

### 5.2. Rework

#### 5.2.1. Use of Hot Air Gun and Solder Iron

##### 5.2.1.1. Component Removal

Use of hot air gun is possible for removal of the component.

Hot air gun temperature:  $365^{\circ}\text{C}$

Recommended time: 60 to 90 sec

---

**Warning:** *If heating conditions are not properly controlled during manual hot removal from PCB assembly, package integrity can be damaged from overheating.*

---

##### 5.2.1.2. Pad Redress

Once the component has been removed, the site and pads need to be cleaned properly. It is better to use the combination of a blade style conductive tool and a fluxed desoldering braid.

Once the residual solder has been removed, the land pads should be cleaned with a solvent. The solvent is usually specific to the type of solder paste used in the original assembly and the paste manufacturer's recommendations should be followed.

### 5.2.1.3. Resoldering the XM Module

Re-soldering can be done as a retouch process by using a hot air gun for preheating and a solder iron for soldering.

## 5.2.2. Use of Rework Machine

### 5.2.2.1. Component Removal

The step consists of reflowing the solder joints attaching the components to the PCB. Ideally, the reflow profile for part removal should be the same as the one used for part attachment. However, the time above liquidus can be reduced if the reflow is complete.

In the removal process, it is recommended that the board should be heated from the bottom side using convective heaters and hot gas, or hot air or IR should be used on the top side of the component. Special nozzles or IR lens should be used to direct the heating in the component area and heating of adjacent components should be minimized.

Excessive hot airflow should also be avoided, as this causes the component to overheat.

Once the joints have reflowed, the vacuum lift-off should be automatically engaged for pick-up during the transition from reflow to cool down.

---

**Warning:** *If heating conditions are not properly controlled during manual hot removal from PCB assembly, package integrity can be damaged from overheating.*

---

### 5.2.2.2. Pad Redress

Once the component has been removed, the site and pads need to be cleaned properly. It is better to use the combination of a blade style conductive tool and a fluxed desoldering braid.

Once the residual solder has been removed, the land pads should be cleaned with a solvent. The solvent is usually specific to the type of solder paste used in the original assembly and the paste manufacturer's recommendations should be followed.

### 5.2.2.3. Solder Paste Deposit

Once the PCB is properly cleaned and inspected, solder paste should be applied on the solder land (on the component itself or on the customer PCB) with a mini-stencil which has the same thickness and apertures as the stencil used for the original attachment.

### 5.2.2.4. New Component Placement

A slip-beam optical system should be used to align the component to the PCB. This method will display an image of the land pad overlaid on the mating footprint and aid in proper alignment. Similar to paste printing, the alignment should be done under magnification of 50x to 100x.

### 5.2.2.5. New Component Soldering

The reflow profile developed during the original attachment or removal should be used to attach the new component.

## 6. Storage and Floor Life Guidelines

### 6.1. Moisture Color Coded Card and Caution Label

The moisture color-coded card provides an insight to the relative humidity in percentage (RH). When the AirPrime XM modules are taken out, the RH level must be below 10%.

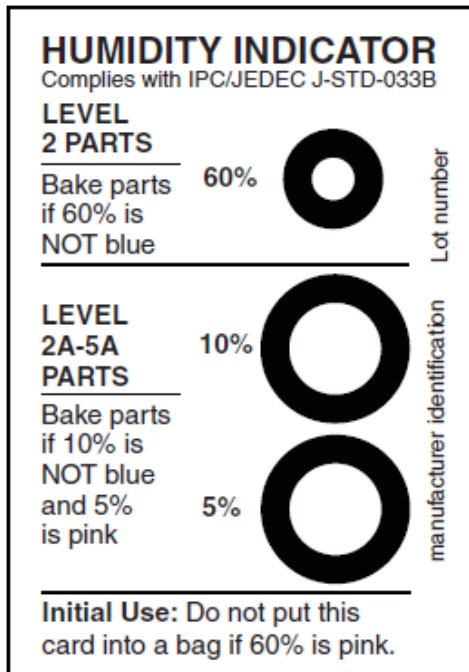

Figure 10. Humidity Indicator Card (HIC) Example

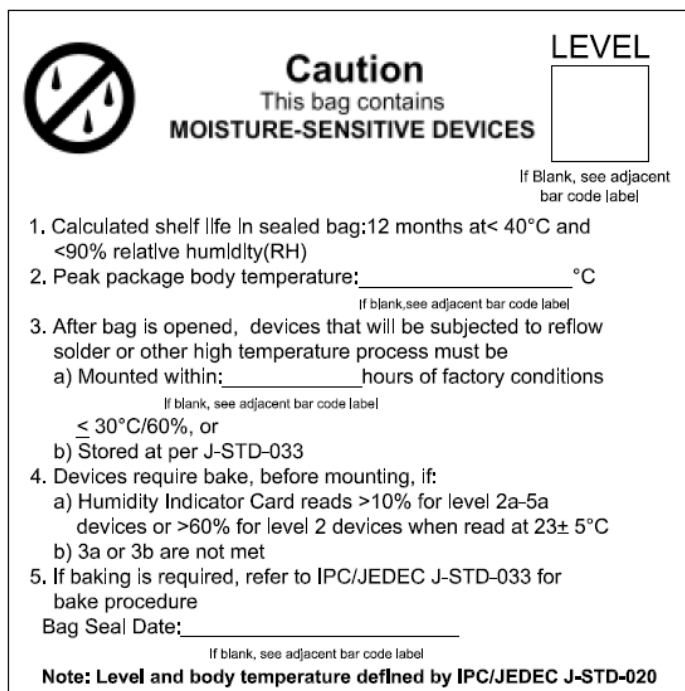

Figure 11. Moisture Caution Label

## 6.2. Conditions for Baking

---

**Important:** *Prior to solder-reflow, baking will be mandatory if the modules meet any of the conditions listed below.*

---

1. The package of the module is broken or leaky when received.
2. The humidity indicator turns blue.
3. The package is opened 12 months after the module was packaged (refer to chapter 2.1.1).
4. The module exposed to controlled ambient atmosphere ( $\leq 30^{\circ}\text{C}$ ; RH 60%) exceeds MSL floor life, as per Table 5.1 of JEDEC J-STD-033C (168h for MSL3 / 72h for MSL 4).

## 6.3. Baking

When the modules are exposed to high temperatures during the solder-reflow process, the moisture vapor pressure inside the modules will increase greatly. To prevent delamination, cracking, or “popcorn effect”, it may need to undergo the baking procedure prior to any high-temperature or solder reflow process. The recommended baking time for the AirPrime XM Series module is described in chapter 2.1.3.

Once baked, the module’s floor life is “reset”, which means the module can be used in normal factory condition accordingly to MSL floor life as per Table 5.1.

---

**Note:** *The “popcorn effect” is when the IC/module “pops” because the moisture inside the package expands in the reflow process.*

---

---

**Important:** *Please limit the number of times that AirPrime XM Series modules undergo the baking process. Repeated baking processes will affect performance of wetting on the SMD pad contacts. This applies to all SMT devices.*

---