



AirLink RV55

Hardware User Guide

Important Notice

Information relating to this product and the application or design described herein is believed to be reliable, however such information is provided as a guide only and Semtech assumes no liability for any errors in this document, or for the application or design described herein.

Semtech reserves the right to make changes to the product or this document at any time without notice. Buyers should obtain the latest relevant information before placing orders and should verify that such information is current and complete. Semtech warrants performance of its products to the specifications applicable at the time of sale, and all sales are made in accordance with Semtech's standard terms and conditions of sale.

SEMTECH PRODUCTS ARE NOT DESIGNED, INTENDED, AUTHORIZED OR WARRANTED TO BE SUITABLE FOR USE IN LIFE-SUPPORT APPLICATIONS, DEVICES OR SYSTEMS, OR IN NUCLEAR APPLICATIONS IN WHICH THE FAILURE COULD BE REASONABLY EXPECTED TO RESULT IN PERSONAL INJURY, LOSS OF LIFE OR SEVERE PROPERTY OR ENVIRONMENTAL DAMAGE. INCLUSION OF SEMTECH PRODUCTS IN SUCH APPLICATIONS IS UNDERSTOOD TO BE UNDERTAKEN SOLELY AT THE CUSTOMER'S OWN RISK. Should a customer purchase or use Semtech products for any such unauthorized application, the customer shall indemnify and hold Semtech and its officers, employees, subsidiaries, affiliates, and distributors harmless against all claims, costs damages and attorney fees which could arise.

The Semtech name and logo are registered trademarks of the Semtech Corporation. All other trademarks and trade names mentioned may be marks and names of Semtech or their respective companies. Semtech reserves the right to make changes to, or discontinue any products described in this document without further notice. Semtech makes no warranty, representation or guarantee, express or implied, regarding the suitability of its products for any particular purpose. All rights reserved.

Wireless Communications

Due to the nature of wireless communications, transmission and reception of data can never be guaranteed. Data may be delayed, corrupted (i.e., have errors) or be totally lost. The Semtech product should not be used in situations where failure to transmit or receive data could result in damage of any kind to the user or any other party, including but not limited to personal injury, death, or loss of property. Semtech accepts no responsibility for damages of any kind resulting from delays or errors in data transmitted or received using the Semtech product, or for failure of the Semtech product to transmit or receive such data.

Warranty

Warranty information for AirLink products is available at www.sierrawireless.com/end-user-warranty.

Safety

Do not operate the Semtech product in areas where blasting is in progress, where explosive atmospheres may be present, near medical equipment, near life support equipment, or near any equipment which may be susceptible to any form of radio interference. In such areas, the Semtech product should be powered off.

The driver or operator of any vehicle should not operate the Semtech product while in control of a vehicle. Doing so will detract from the driver or operator's control and operation of that vehicle. In some states and provinces, operating such communications devices while in control of a vehicle is an offence.

The RV55 platform is classified to ANSI/ISA 12.12.01-2016 and CSA C22.2#213 and are suitable for use in Class 1, Division 2, Groups A, B, C and D T4, and Class I Zone 2 Group IIC T4 classified Hazardous Locations.

The following warnings and instructions apply:

Warning: *EXPLOSION HAZARD—SUBSTITUTION OF COMPONENTS MAY IMPAIR SUITABILITY FOR CLASS I, DIVISION 2 and CLASS I, ZONE 2.*

Warning: *EXPLOSION HAZARD—DO NOT DISCONNECT WHILE CIRCUIT IS LIVE UNLESS THE AREA IS KNOWN TO BE NON-HAZARDOUS.*

Warning: *DO NOT USE THE USB CONNECTOR IN A HAZARDOUS AREA.*

Warning: *DO NOT USE THE RESET BUTTON IN A HAZARDOUS AREA.*

Avertissement: *RISQUE D'EXPLOSION—LA SUBSTITUTION DE COMPOSANTS PEUT RENDRE CE MATERIEL INACCEPTABLE POUR LES EMPLACEMENTS DE CLASSE I, DIVISION 2 et CLASSE I, ZONE 2.*

Avertissement: *RISQUE D'EXPLOSION—NE PAS DEBRANCHER TANT QUE LE CIRCUIT EST SOUS TENSION, A MOINS QU'IL NE S'AGISSE D'UN EMPLACEMENT NON DANGEREUX.*

Avertissement: *NE PAS UTILISER DE CONNECTEUR USB DANS LES ENVIRONNEMENTS DANGEREUX.*

Avertissement: *NE PAS UTILISER LE BOUTON DE RESET DANS UN ENVIRONNEMENT DANGEREUX.*

This device is suitable for use in Class 1 Div 2 Groups A, B, C, and D T4 locations. Ambient temperatures of -30C to +60C. UL Listed for use in ambient temperatures not exceeding 60C.

Warning: *Explosion Hazard—Do not connect or disconnect while circuit is live or unless the area is known to be free of ignitable concentrations.*

Cet appareil est certifié pour l'usage dans la Classe I, des endroits Devision 2, Groupes atmosphérique A, B, C et de D, T4. La temp ambiante -30C à +60C. UL Listed pour utilisation dans des températures ambiantes ne dépassant pas 60C.

Avertissement: *Risque D'Explosion. Ne pas débrancher tant que le circuit est électrié sauf si il n'y a aucune concentration de vapeurs combustible.*

The device is required to be installed in a tool-secured enclosure with the appropriate type rating.

Sierra Wireless

Semtech Corporation purchased Sierra Wireless in January 2023. The Sierra Wireless brand is gradually being phased out. During the phase-out period, references to both "Semtech" and "Sierra Wireless" may appear in product documentation.

Contact Information

Sales information and technical support, including warranty and returns	Web: sierrawireless.com/company/contact-us/ Global toll-free number: 1-877-687-7795 6:00 am to 5:00 pm PST
Corporate and product information	Web: sierrawireless.com

Contents

- Important Notice 2
- Wireless Communications..... 2
- Warranty..... 2
- Safety..... 2
- Sierra Wireless 3
- Contact Information 4

- Introduction to the AirLink RV55 8**
 - Key Features 8
 - Description..... 9
 - Router Configuration and Management 10
 - Power Modes 10
 - Power draw10
 - Power Saving Features 11
 - Sample Power Consumption Scenarios..... 12
 - Dual SIM 13
 - Network Operator Switching 13
 - Accessories 13
 - Warranty..... 13

- Installation and Startup 14**
 - Tools and Materials Required..... 14
 - Installation Overview 14
 - Step 1 — Insert the SIM Cards 15
 - Step 2 — Mounting the RV55 Router..... 16
 - Mounting Brackets16
 - Flat Surface Mount16
 - DIN Rail Mount17
 - Grounding the RV55 Router Chassis18
 - Step 3 — Connect the Antennas 18
 - Recommended Antenna Separation20

Step 4 — Connect the Data Cables	20
USB Port	21
Ethernet Port	21
Serial Port	21
Step 5 — Connect the Power	22
Cable Strain Relief	23
Fusing	23
DC Voltage Transients	23
Power Connector on the RV55 Router	24
Wiring Diagrams	26
I/O Configuration	28
Step 6 — Check the Router Operation	34
LED Behavior	35
Ethernet LEDs	36
Step 7 — Startup and Software Configuration	37
Configuring with AMM	38
Reboot the RV55 Router	38
Reset the RV55 Router to Factory Default Settings	38
Recovery Mode.....	39
Specifications at a Glance	40
Certification and Interoperability.....	40
Environmental Testing.....	40
Reliability Specifications	41
Included Radio Module Firmware	42
Host Interfaces	43
SIM Card Interface	44
Operating Voltage	45
Power Specifications	45
GNSS Technology.....	45
GNSS Bands supported	46
Protocols.....	47

Wi-Fi Performance	47
Wi-Fi Channels Supported.....	47
Wi-Fi Antenna Gain	48
Radio Frequency Bands	49
Carrier Aggregation Combinations	58
Mechanical Specifications	62
Screw Torque Settings	63
Regulatory Information	64
Important Information for North American Users	64
RF Exposure	64
EU	65
Notice for Brazilian Users	66
IECEX Compliance.....	66
Applicable standards	66
WEEE Notice	67
Accessories.....	68
DC Power Cable (Black Connector)	68
AC Power Adapter (Black Connector).....	69
AC Power Adapter Input	69
AC Power Adapter Output	69
AC Power Adapter Environmental Specifications	70
AC Power Adapter Reliability and Quality Control	70
AC Power Adapter Safety Standards	70
AC Power Adapter EMC Standards	71
AC Power Adapter Hazardous Substances	71
AC Power Adapter Energy Efficiency	71
Dual Serial Port Adapter Cable.....	72
Index.....	73

1: Introduction to the AirLink RV55

The Semtech® AirLink® RV55 LTE-A Pro router is a compact, intelligent and fully-featured communications platform that provides real-time wireless capabilities for fixed and mobile applications. It is intended for use in industrial settings such as:

- Remotely monitoring and controlling infrastructure and surveillance equipment on pipelines, meters, pumps and valves in any energy, utility, or industrial application
- Tracking the location of heavy equipment and assets in the field
- Providing reliable Internet access to a mobile workforce

The RV55 router has multiple communication ports including serial, Ethernet, and USB ports. The power connector has one GPIO pin for remote monitoring and control and one ignition sense pin to turn the router on and off.

The RV55 is an LTE-Advanced cellular router that supports LTE and HSPA+ radio bands.

The RV55 routers, with their rich feature set, configurable with the included ALEOS software, are the perfect choice for a broad set of IoT solutions.

Key Features

- High-performance LTE-Advanced Pro (Cat-12), LTE (Cat4)
- LTE performance at 2G power consumption (less than 1 W in idle mode)
- State of the art LTE coverage:
 - 21 LTE frequency bands, with support for band 48 Private Network (CBRS)
- FirstNet support (Band 14) with Carrier Aggregation
- CBRS support (Band 48)
- Dual Wi-Fi 2.4/5 GHz
- Dual serial port mode (accessory required)
- Fully automatic network operator switching; just insert the SIM card
- Provides network connectivity via Ethernet, Serial, and USB
- Gigabit Ethernet support (10/100/1000)
- Remote configuration, software update, and monitoring with AirLink Management Service (ALMS)
- Meets industrial-grade certifications including Class 1 Div 2, Class I Zone 2, MIL-STD-810G, IP64 ingress protection
- Supports up to 5 VPN tunnels to support secure communications over cellular networks
- Events engine for alert reporting to third party server platforms
- ALEOS Application Framework (AAF) offers real-time onboard data processing
- Built-in, class-leading voltage transient protection provides superior reliability and continuous operation
- E-Mark and SAEJ1455 for shock and vibration
- Active GNSS for tracking equipment
- Preprogrammed low voltage disconnect to prevent battery drain
- Security via Remote Authentication (RADIUS, TACACS+, LDAP) to centrally manage router access
- **Power Saving Features**, including:
 - LED Power Saving Mode
 - Standby mode
 - Power saving strategies such as turning off unused interfaces (USB, Serial, Ethernet), turning off GNSS, and adjusting the Ethernet data rate
- Multi-function digital input, analog input, switchable low side current sink, and high side configurable pull-up

For information on configuring these features, refer to the [ALEOS Software Configuration User Guide for AirLink RV55](#).

Description

Back Panel

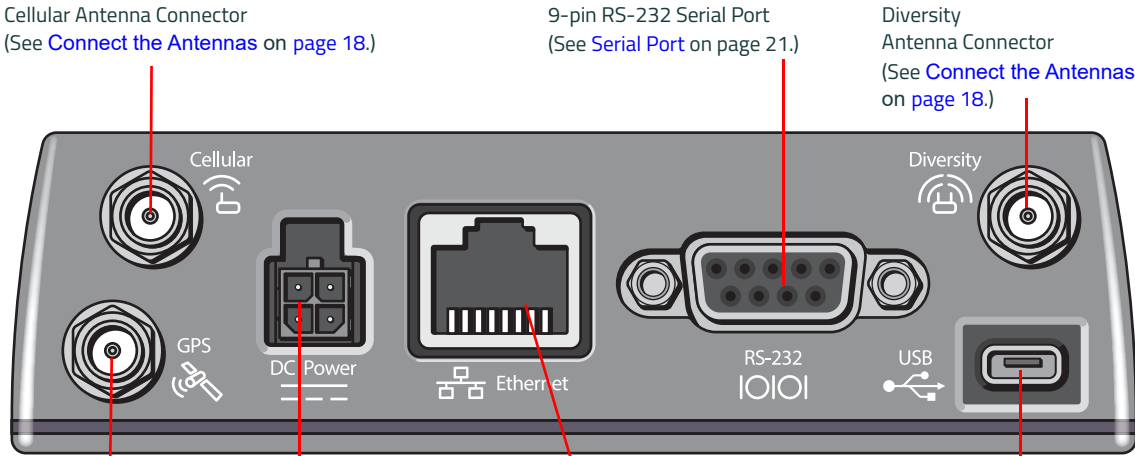

Front Panel

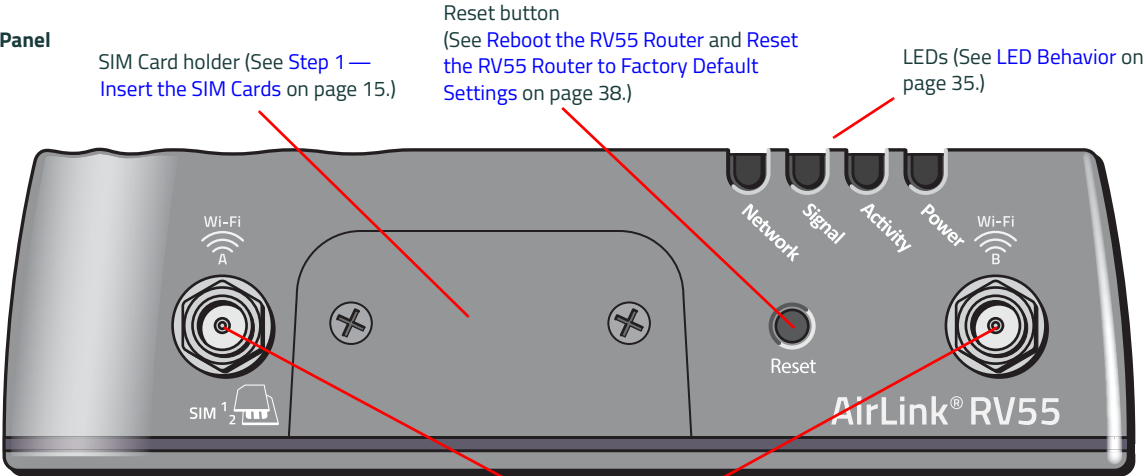

Wi-Fi antenna connectors (Wi-Fi models only)

Figure 1-1: RV55 Router Connectors, LEDs and SIM Card Holder

Router Configuration and Management

You can configure and manage your RV55 router using:

- **ACEmanager** — a browser-based router management application
Refer to the ALEOS Software Configuration User Guide available for download at source.sierrawireless.com.
- **AirLink Management Service (ALMS)** — a cloud-based router management service provided by Semtech
For more information, visit www.sierrawireless.com/ALMS or contact your Semtech distributor.
- **AirLink Mobility Manager (AMM)** — a Network Management solution that provides a consolidated view of the entire vehicle fleet and enables simplified management, control and monitoring of connected AirLink routers.
- **AT Commands**
For a complete list of AT Commands, refer to the ALEOS Software Configuration User Guide.

Power Modes

The AirLink RV55 router has two power modes:

- Idle Connected — The CPU and the radio are on.
- Standby — The CPU and the radio are off, but can be woken by an I/O input or at a configured time.

Power draw

The figures in [Table 1-1](#) show the power draw for each power mode at 12 VDC.

Table 1-1: RV55 power draw

Idle Connected ^a	Standby
LTE: 834 mW (69 mA)	53 mW (4.42 mA)
LTE-A Pro: 717 mW (60 mA)	

a. Router is idle (no traffic is being sent or received)

Power Saving Features

Table 1-2 provides a quick reference to the RV55 power saving features. For more information, refer to the [ALEOS Software Configuration User Guide](#).

Table 1-2: Power Saving Features

Feature	Where to configure in ACEmanager	Notes
LED Power Saving	Services > Power Management	<p>In LED Power Saving Mode:</p> <ul style="list-style-type: none"> Signal LED is off when the signal strength is good or average, but still alerts you when there is no signal or a poor signal. Network LED is off when there is a network connection, but alerts you when the router is connecting to a network and when there is a problem with the network connection. <p>For more details, see LED Behavior on page 35.</p>
Disable USB Port	LAN > USB	
Disable Ethernet Port	LAN > Ethernet	
Set Ethernet Data Rate	LAN > Ethernet > Advanced	Ethernet data rates can be set to Auto, 100 Mbits, 10 Mbits. If your use case does not require a Gigabit Ethernet connection, choosing a slower rate results in substantial power savings. When set to 10 or 100 Mbits, both sides of the link must be set to the same fixed speed and duplex settings. If you are unable to ensure that both sides of the link have exactly the same fixed settings, it is best to use Auto.
Disable Serial Port	Serial > Port Configuration	
Disable GNSS	GPS > Global Settings	GNSS is disabled by default.
Ignition Shutdown Delay	Services > Power Management	If the RV55 router is installed in a vehicle, connect the ignition sense pin (Pin 3) on the DC power cable to the vehicle ignition and configure the RV55 router to shut down after a configured delay once the ignition is turned off.
Low Voltage Disconnect		The RV55 router enters standby mode when the voltage reaches a user-defined threshold to prevent excessive battery drain in battery-operated systems.
Standby (Time-based)		The RV55 router is in standby mode and automatically wakes up periodically, for example hourly or daily.
Standby (I/O-based)		The RV55 router is in standby mode and automatically wakes up on configured I/O input.

Sample Power Consumption Scenarios

Power consumption was measured at 12 V.

Table 1-3: Power Consumption Scenarios

Scenario	Radio	Notes	LTE Power ^a
Standby Mode	—	—	50 mW (4.17 mA)
Low Power — Serial	Idle Attached	Serial enabled	900 mW (75 mA)
Low Power — Ethernet	Idle Attached	10 BaseT Full duplex	990 mW (82.5 mA)
Low Power — Wi-Fi ^b	Idle Attached	—	1300 mW (108 mA)
Typical without Power Saving Features ^c	Attached and connected (+20 dBm LTE)	100 BaseT Full duplex, serial and USB enabled (idle), GNSS enabled (active antenna)	3700 mW (308.3 mA)
Maximum without Power Saving Features	Attached and connected (+23 dBm LTE-A)	1000 BaseT Full duplex (maximum throughput), serial and USB enabled, GNSS enabled (active antenna)	5500 mW (458.3 mA)
Inrush Current	1.5 A @ 12 V (Averaged over 100 μ s)		

- a. Typical power/current draw measurements are expected to be within $\pm 10\%$ of stated values at 20° C.
- b. Wi-Fi A and B set up as access points with nothing connected to them.
- c. LED Power Saving Mode.

Table 1-4: Thermal Output Specifications

Scenario	Power (Watts)	BTU/Hour
Standby	0.050	0.171
Low Power Serial	0.9	3.071
Low Power Ethernet	0.99	3.378
Typical without power saving features	3.700	12.620
Max without power saving	5.500	18.770

Dual SIM

The AirLink RV55 router has two SIM card slots. You can configure which slot is the Primary SIM card—by default, the upper SIM slot is for the Primary SIM card. To configure the Primary and Secondary SIM card slots, see the WAN/Cellular settings in ACEmanager.

When the router is powered on or reboots, it automatically connects to the network associated with the Primary SIM card. If no card is present in that slot, it connects to the network associated with the Secondary SIM card. If configured to do so, data usage is tracked independently on both SIM cards. SIM PIN configuration is also available for both SIM cards. This feature allows users to install SIM cards for two different network operators, use one SIM card initially and later change network operators by configuring the new SIM card to be the Primary SIM card.

Network Operator Switching

The North American AirLink RV55 comes preloaded with multiple versions of radio module firmware. When the router is powered on, it checks the stored radio module firmware versions and automatically loads the appropriate version for the installed Primary SIM card onto the radio module. While Network Operator Switching is in progress, the LEDs sequentially flash green (green LED chase).

If there is no SIM card installed in the Primary SIM card slot, the router uses the firmware associated with the SIM card in the Secondary SIM card slot.

This feature, which is intended for North American products, makes it possible to use a single hardware variant on multiple operator networks.

Accessories

The following items come with the RV55 router:

- DC power cable
- Mounting screws
- Quick Start Guide

The following items can be ordered separately from Semtech:

- Universal AC power adapter
 - Voltage input: 100–240 VAC
 - Current output: 1.5 A
 - Part number: 2000579
- DIN rail mounting bracket (part number 6001529, see [DIN Rail Mount](#) on page 17)
- Serial Y-cable for dual serial port mode operation
 - Part number: 6001238

Warranty

You can download the RV55 router warranty from [the Semtech Source](#). Click **sign up** to register for free.

2: Installation and Startup

This chapter shows how to connect, install and start the AirLink RV55 router. It also describes the front panel LEDs, and I/O functionality.

Note: Field wiring and connections in hazardous locations must be connected as per the wiring methods requirement for Class 2 circuits mentioned in the National Electric Code and the Canadian Electric Code.

Note: The RV55 router installation must be done by a qualified technician.

Tools and Materials Required

- Power supply — AC or DC (DC power cable is supplied by Semtech)
- A SIM card (provided by your mobile network operator)
- #1 Phillips screwdriver
- Laptop computer with Ethernet cable
- LTE MIMO antennas — Main and Diversity
- Optional — GPS antenna
- Optional — a 9-pin connection cable for the RS-232 port
- Optional — DIN Rail Mounting Bracket kit (available from Semtech)

Caution: *The router has a hardened case for use in industrial and extreme environments. If you are installing it in these types of environments, use cables designed and specified for use in these types of environments to avoid cable failure.*

Installation Overview

The steps for a typical installation are:

1. Insert the SIM card(s) — [page 15](#).
2. Mount the RV55 router — [page 16](#).

Note: Depending on where you are installing the RV55 router, you may want to mount the router after connecting the antenna, cables and power, and confirming correct operation.

3. Connect the antennas — [page 18](#).
4. Connect the data cables — [page 20](#).
5. Connect the power — [page 22](#).
6. Check the router operation — [page 34](#).
7. Connect a laptop and configure ACEmanager — [page 37](#).

The following sections describe these steps in detail.

Step 1 — Insert the SIM Cards

The AirLink RV55 router has two mini-SIM (2FF) card slots. The upper slot is Slot 1 and the lower slot is Slot 2. ACEmanager references these slot numbers, and by default, the SIM card in Slot 1 is the Primary SIM card. If you are using only one SIM card, Semtech recommends that you install it in Slot 1.

If the SIM card (or SIM cards) have not already been installed, insert the SIM cards into the router before connecting any external equipment or power to the router.

To install the SIM cards:

1. Use a #1 Phillips screwdriver to remove the SIM card cover.
2. Orient the SIM card(s), as shown in [Figure 2-1](#). The gold contacts on the upper SIM card face down, and the gold contacts on the lower SIM card face up. If you are using only one SIM card, insert it in the upper SIM slot (Slot 1).
3. Gently slide the SIM cards into the slots until they click into place.

To remove a SIM card, press the SIM card in, and release it. Gently grip the SIM card and pull it out.

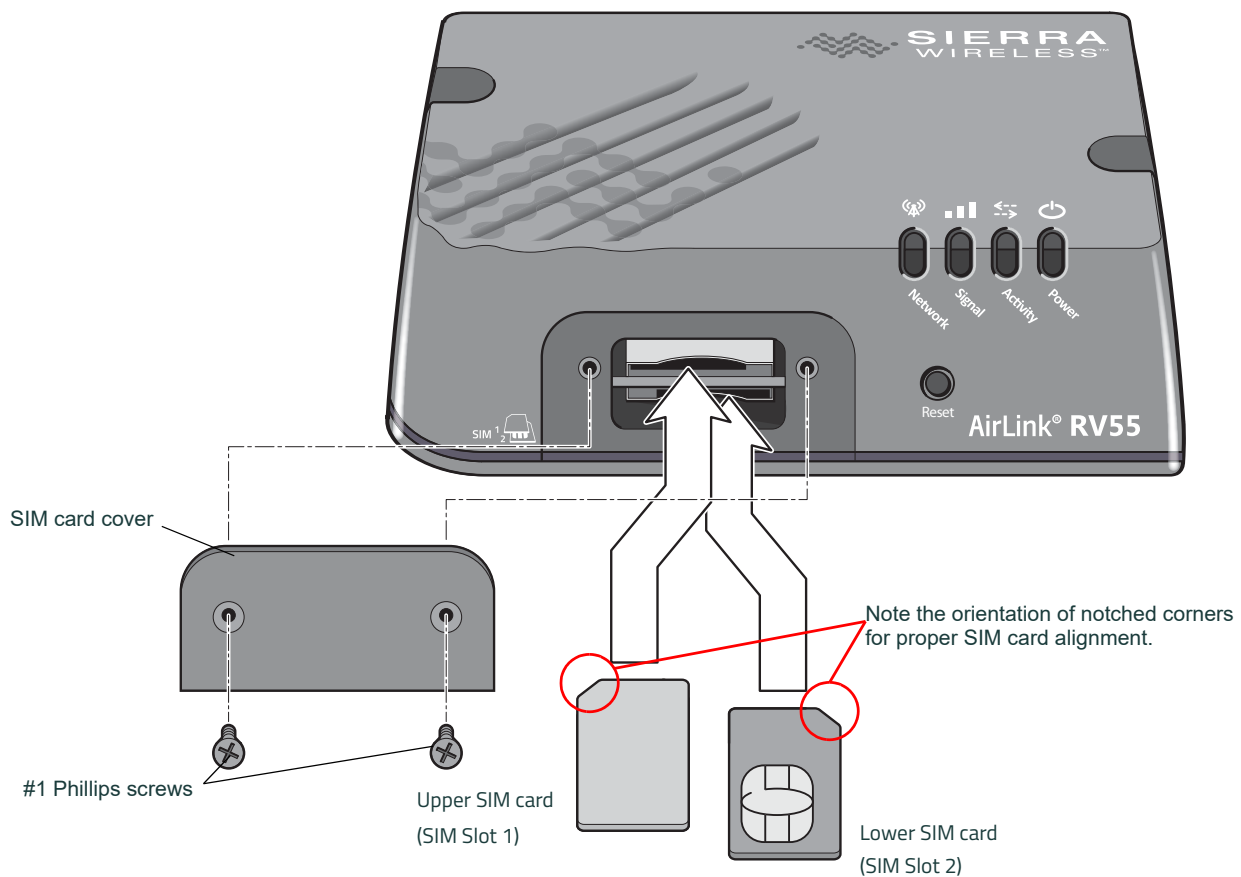

Figure 2-1: Installing the SIM Card

4. Replace the SIM card cover.

Step 2 — Mounting the RV55 Router

Warning: This router is not intended for use close to the human body. Antennas should be at least 8 inches (20 cm) away from the operator.

Mount the router where:

- There is easy access to the cables
- Cables are not bent, constricted, close to high amperages or exposed to extreme temperatures
- The front panel LEDs are easily visible
- There is adequate airflow
- It is away from direct exposure to the elements, such as sun, rain, dust, etc.
- It will not be hit or come into contact with people, cargo, tools, equipment, etc.

Mounting Brackets

The RV55 router comes with mounting screws. An optional DIN rail mounting bracket (P/N 6001529) is available from Semtech. See [DIN Rail Mount](#) on page 17.

Flat Surface Mount

If you are mounting the RV55 router on a flat surface, use the mounting screws that come with the router.

Note: When mounting the router in a location that could be exposed to rain (such as in a vehicle door panel, which would expose the router when the door is opened), mount the router vertically with the power connector and ports facing down, as shown in [Figure 2-2](#). The router meets its IP64 rating when mounted in this orientation.

Note: RV55 Wi-Fi model shown. Mounting hole measurements are the same for all RV55 models.

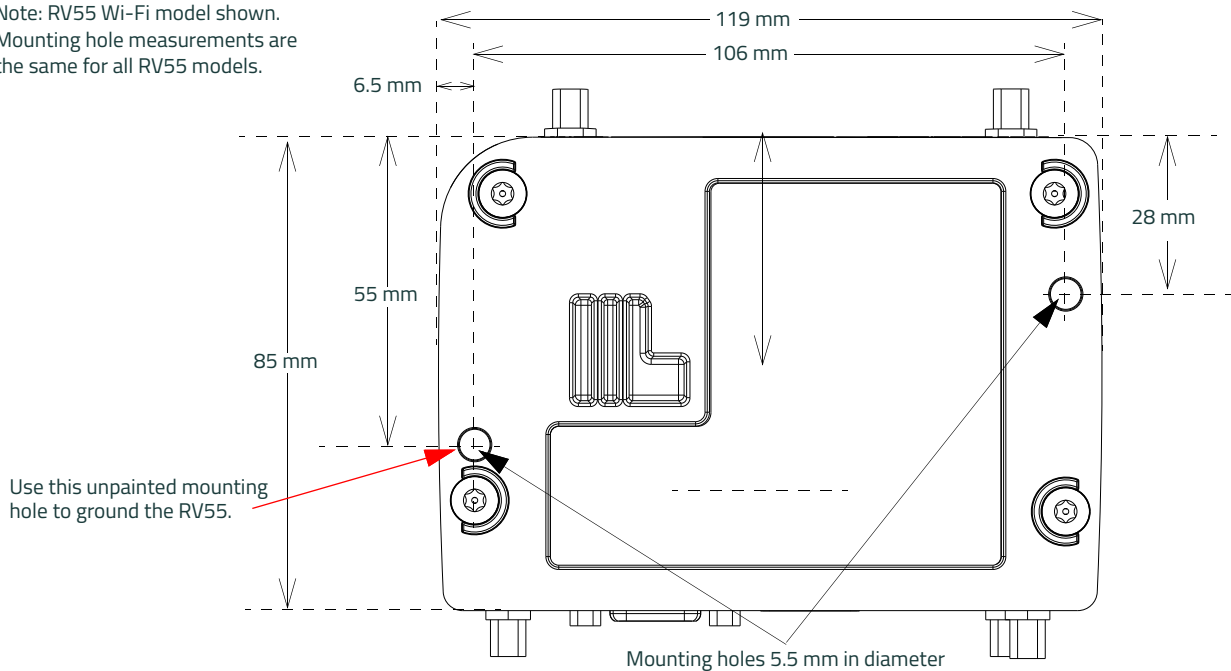

Figure 2-2: RV55 Router Mounting Hole Locations and Dimensions

DIN Rail Mount

If you are mounting the RV55 router on a DIN rail, order DIN rail mounting bracket kit (P/N 6001529) from Semtech. The kit contains:

- L-shaped DIN Rail Mounting Bracket—Qty 1
- DIN Rail Clip (35 mm EN 50022)—Qty 1
- Screws

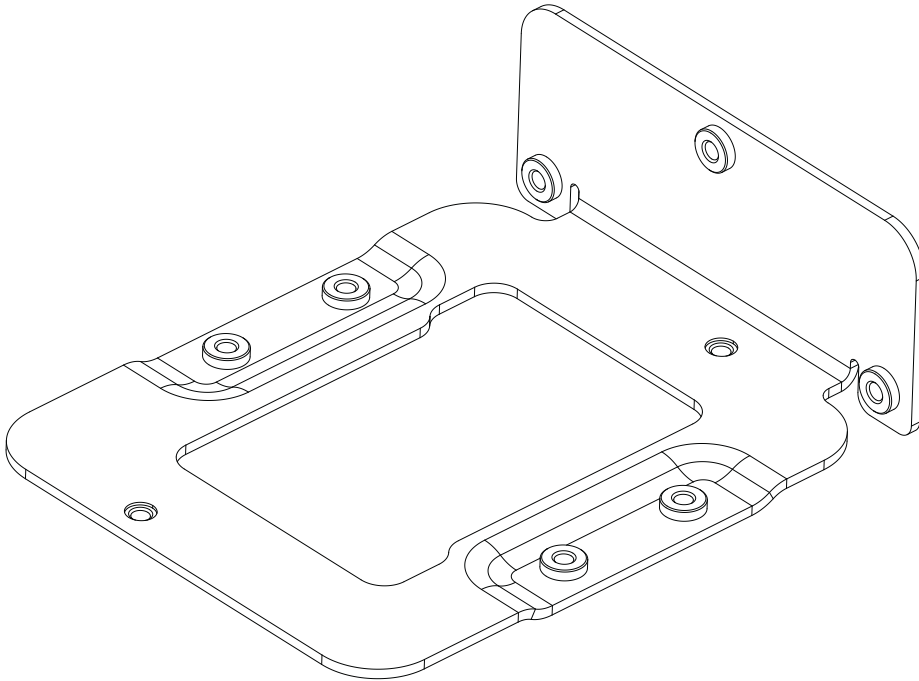

Figure 2-3: DIN Rail Mounting Bracket

To attach the RV55 router to a horizontally mounted DIN rail, in a variety of orientations:

1. Install the SIM card. (See [Step 1 — Insert the SIM Cards](#) on page 15.)
2. Test the network connectivity.
Connect the RV55 router. Power it up and ensure that you have network connectivity. (See [Step 5 — Connect the Power](#) on page 22.)
3. Place the router on the DIN rail mounting bracket, lining up the mounting holes on the underside of the router with the holes on the DIN rail mounting bracket.
4. Use the screws provided to attach the router to the bracket. Torque the screws to a maximum of 1.1 N-m (10 in-lb.).
5. Use the screws provided to attach the DIN rail clip to the bracket.
6. Attach the DIN rail clip to a horizontal DIN rail, with the spring clip at the bottom.

Note: The DIN rail mounting bracket and clip in the Semtech kit should only be used on horizontally-mounted DIN rail.

Grounding the RV55 Router Chassis

For DC installations (with a fixed “system” ground reference), Semtech strongly recommends always grounding the RV55 chassis to this system ground reference.

To ensure a good grounding reference, either:

- Attach the RV55 to a grounded metallic surface.
- Connect one end of a short 18 AWG or larger gauge wire to the unpainted upper left mounting hole (see [Figure 2-2](#)) and connect the other end to the system ground reference or (if mounted in a vehicle) the vehicle chassis.

Note: In some routers the upper left mounting hole is painted. If you use the mounting screw and washer included with your router, this mounting hole still provides an effective ground, as the washer removes enough paint to allow contact between the wire and the metal chassis.

Step 3 — Connect the Antennas

Warning: *This router is not intended for use close to the human body. Antennas should be at least 8 inches (20 cm) away from the operator.*

The RV55 router has up to three female SMA antenna connectors. The number of connectors depends on product variant:

- Cellular Main antenna connector
- Cellular Diversity antenna connector: Required for 4G/LTE networks
- GPS antenna connector

In addition, the RV55 with Wi-Fi has two male SMA antenna connectors (see [Figure 2-4](#) on page 19).

For regulatory requirements concerning antennas, see [Maximum Antenna Gain](#) on page 65.

Note: The antenna should not exceed the maximum gain specified in [RF Exposure](#) on page 64. In more complex installations (such as those requiring long lengths of cable and/or multiple connections), you must follow the maximum dBi gain guidelines specified by the radio communications regulations of the Federal Communications Commission (FCC), Industry Canada, or your country’s regulatory body.

Note: Take extra care when attaching the antennas to the SMA connectors. Finger tight (approximately 0.6 – 0.8 Nm/5 – 7 in-lb.) is sufficient and the max torque should not go beyond 1.1 Nm (10 in-lb.).

To install the antennas:

1. Connect the cellular antenna to the SMA cellular antenna connector.
Mount the cellular antenna so there is at least 20 cm between the antenna and the user or bystander.
2. Connect a second antenna to the SMA Diversity antenna connector.
For 3G networks, the second antenna operates as a diversity antenna, providing a second receive path.
For 4G networks, the second antenna operates as a MIMO antenna, providing a second receive path and a second transmit path.
3. If used, connect a GPS antenna to the SMA GPS antenna connector.
Mount the GPS antenna where it has a good view of the sky (at least 90°).

Note: ALEOS is configured by default for an active GPS / GNSS antenna. If you are using a passive antenna, after the router is installed, launch ACEmanager, go to Location > Advanced and set the GNSS Antenna Bias field to Disable.

4. For Wi-Fi-capable routers, connect the Wi-Fi antennas to the SMA Wi-Fi connectors.

Note: If any antenna is located away from the router, keep the cables as short as possible to prevent the loss of antenna gain. Route the cables so that they are protected from damage and will not be snagged or pulled on. There should be no binding or sharp corners in the cable routing. Excess cabling should be bundled and tied off. Make sure the cables are secured so their weight will not loosen the connector from the router over time.

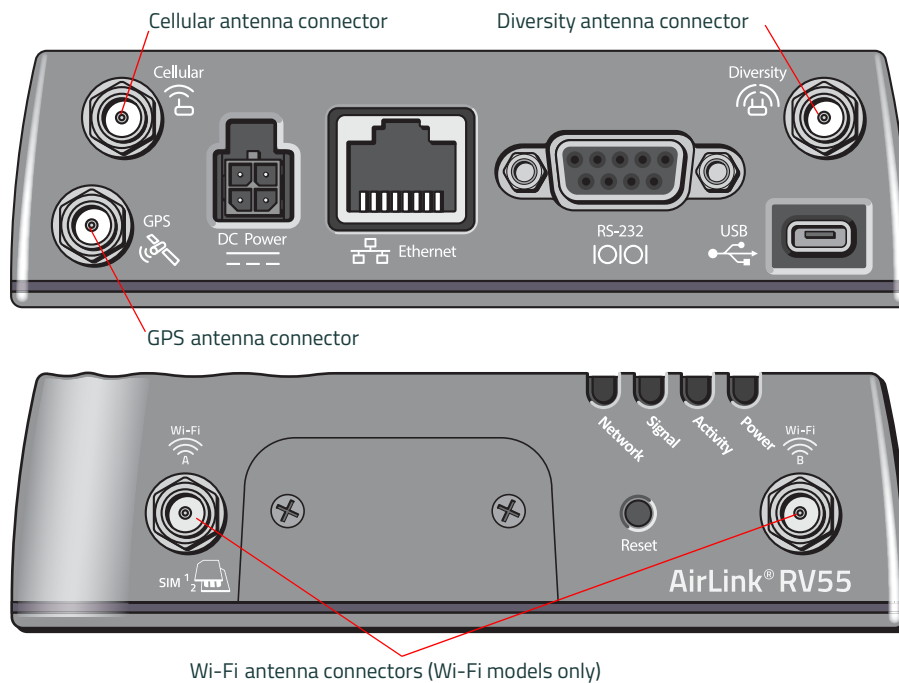

Figure 2-4: Antenna Connectors

Recommended Antenna Separation

The recommended antenna separation is related to the band frequency/wavelength. To accommodate the shortest frequency/longest wavelength band supported by the RV55, Semtech recommends a minimum antenna separation of 214 mm for best results, and if necessary, a separation of 107 mm for acceptable results.

Table 2-1: Recommended Antenna Separation

Service	Frequency (MHz)	Wavelength (λ) (mm)	Best Antenna Separation (mm) ($1/2 \lambda$)	Good Antenna Separation (mm) ($1/4 \lambda$)
LTE	700	428	214	107
LTE	800	375	187	94
LTE	900	333	167	83
LTE	1800	167	83	42
LTE	2100	143	71	36
LTE	2600	115	58	29
WCDMA	850	353	176	88
WCDMA	900	333	167	83
WCDMA	1900	158	79	39
WCDMA	2100	143	71	36
GSM/GPRS/EDGE	850	353	176	88
GSM/GPRS/EDGE	900	333	167	83
GSM/GPRS/EDGE	1800	167	83	42
GSM/GPRS/EDGE	1900	158	79	39

Step 4 — Connect the Data Cables

The RV55 router has the following ports for connecting data cables:

- [USB Port](#) (Micro-AB)
- [Ethernet Port](#) (RJ-45) — Use a Cat 5e or Cat 6 Ethernet cable
- [Serial Port](#) (9-pin RS-232)

USB Port

Warning: *Do not use the USB port in a potentially explosive environment.*

The USB port complies with USB Version 2.0 for high speed operation and can be configured to operate in one of two modes:

- **Virtual Ethernet Port:** The RV55 behaves as if the PC were connected to an Ethernet port, allowing access to the Internet and the router's internal web server. This is the default setting.
- **Virtual Serial Port:** The RV55 behaves as if it was connected to a standard serial port. The primary use of this interface is for the AT command line interface of ALEOS and for diagnostic access to the radio module.

A Windows driver must be installed on the PC in order to support USB virtual serial port mode. You can download the drivers from

source.sierrawireless.com/resources/airlink/software_downloads/airlink_usb_driver/

For information about setting the USB mode and installing the USB driver, see the ALEOS Software Configuration User Guide.

Semtech recommends you:

- Use a USB 2.0 cable
- Connect directly to your computer for best throughput.

Ethernet Port

- IEEE 802.3 Ethernet specification for 1000 Mbps speed (Gigabit Ethernet) with fallback to 100 or 10 Mbps (Cat 5e or Cat 6 cable is required for Gigabit Ethernet)
- Auto-crossover support
- Auto-negotiation detects the speed of the connecting device for 1000 baseT, 100 baseT, or 10 baseT

To optimize Ethernet throughput, ensure that you update:

- Windows, to 10.0.19042 or later
- Your PC's Ethernet driver

Check your Windows Device Manager for the current driver settings. (For Dell laptops with an Intel Ethernet Connection I219-LM, update to 12.19.0.18 or later.)

Serial Port

The RV55 9-pin serial port connects directly to most computers or other devices with a standard serial straight-through cable.

Note: If you have a DCE device, you need to use a null modem (cross-over) cable.

The same serial port can be configured as a dual 4-wire serial port, and connect to devices with a Y cable (Semtech part number 6001238). The Dual Port Mode setting is available in ACEmanager under Serial > RS232 Configuration > General.

- Used for connecting serial devices and configuration
- Complies with the EIA RS-232D specification for DCE equipment
- Output driver levels swing from -7 VDC to +7 VDC with normal loading

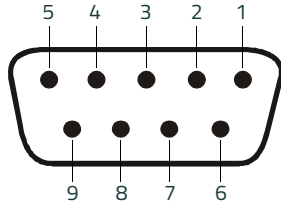

Figure 2-5: DB-9 Female Serial Connector

Table 2-2: Serial Connector Pin-out (Single Port Mode)

Name	Pin	Description	Type
DCD	1	Data Carrier Detect	OUT
RXD	2	Receive Data	OUT
TXD	3	Transmit Data	IN
DTR	4	Data Terminal Ready	IN
GND	5	Main GND. Connected internally to BOARD GND	GND
DSR	6	Data Set Ready	OUT
RTS	7	Ready To Send	IN
CTS	8	Clear To Send	OUT
RI	9	Not connected	—

Table 2-3: Serial Connector Pin-out (Dual Port Mode)

Name	Pin	Description	Type
CTS_2	1	Port 2 Clear To Send	OUT
RXD	2	Port 1 Receive Data	OUT
TXD	3	Port 1 Transmit Data	IN
TXD_2	4	Port 2 Transmit Data	IN
GND	5	Main GND. Connected internally to BOARD GND	GND
RXD_2	6	Port 2 Receive Data	OUT
RTS	7	Port 1 Ready To Send	IN
CTS	8	Port 1 Clear To Send	OUT
RTS_2	9	Port 2 Ready To Send	IN

Step 5 — Connect the Power

The AirLink RV55 router comes with a 3 meter (10 ft.) DC power cable. You can also purchase an optional AC adapter.

Note: Electrical installations are potentially dangerous and should be performed by personnel thoroughly trained in safe electrical wiring procedures.

The RV55 router supports a voltage range between 7 V and 36 V, but since low voltage standby mode is enabled by default, you must supply greater than 9 volts at startup.

If you want to operate the router at a lower voltage, change the low voltage settings once the router is up and running. For more information, refer to the ALEOS Software Configuration User Guide (Services chapter).

Cable Strain Relief

Semtech recommends using cable strain relief for installations in high-vibration environments.

Place the cable strain relief within 200 mm (8 in.) of the RV55 router to reduce the mass of cable supported by the power connector under vibration. Ideally, the strain relief mounting for the DC cable should be attached to the same object as the router, so both the router and cable vibrate together. The strain relief should be mounted such that it does not apply additional stress on the power connector, i.e. the cable should not be taut and should not pull the power connector at an angle.

Fusing

For DC installations, Semtech recommends fusing the power input using a 4.0 A fast-acting fuse.

DC Voltage Transients

The AirLink RV55 router has built-in protection against vehicle transients including engine cranking (down to 5.0 V) and load dump, so there is no need for external power conditioning circuits. For details, see [Industry Certification for Vehicles](#) on page 40.

Power Connector on the RV55 Router

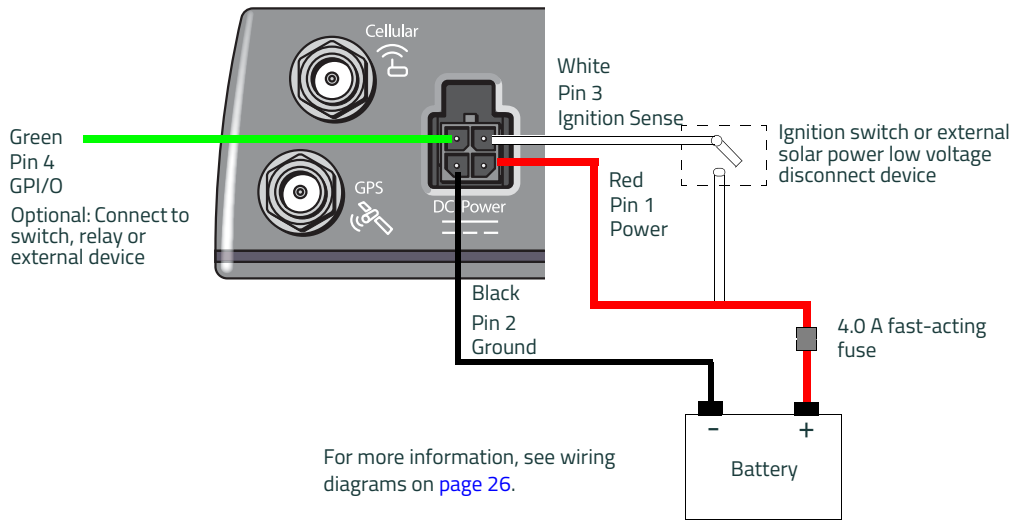

Figure 2-6: DC Power Cable Connections (Colors indicate DC cable wire colors.)

Table 2-4: Power Connector Pin and DC Cable Wires

Pin	Name	DC Cable Wire Color	Description	Type
1	Power	Red	Main power supply for device <i>Note: When the router switches to Low Power mode based on a Low Voltage trigger, the voltage is monitored on the Red (Power) wire.</i>	PWR
2	Ground	Black	Main device ground	PWR

Table 2-4: Power Connector Pin and DC Cable Wires

Pin	Name	DC Cable Wire Color	Description	Type
3	Ignition Sense	White	<p>Semtech recommends using the Ignition Sense wire to turn the router off. It should not be turned off by disconnecting the power.</p> <hr/> <p><i>Note: If you do not connect pin 3 to the ignition, you MUST connect it to the positive terminal of your power supply or battery. If you are using a Semtech AC adapter, the connection is inside the cable.</i></p> <hr/> <p>For installations where the router is turned on/off, use the white wire in the DC cable connected to Pin 3 to:</p> <ul style="list-style-type: none"> Turn the router on/off with the vehicle ignition <hr/> <p><i>Note: To turn the router on/off with the vehicle ignition, Semtech strongly recommends using an unswitched VCC on Pin 1 (Red, Power wire on DC cable) with Pin 3 (White, Ignition sense wire on DC cable) connected to the ignition.</i></p> <hr/> <ul style="list-style-type: none"> Turn the router on/off with a low voltage disconnect device <hr/> <p><i>Note: For solar applications, if you want the router to turn off when the voltage drops below a defined level, connect Pin 3 to an external low voltage disconnect.</i></p> <hr/>	I
4	GPIO	Green	User configurable digital input/output or analog voltage sensing input. Connect to switch, relay or external device. For more information, see I/O Configuration on page 28 and the ALEOS Software Configuration User Guide.	I/O

Wiring Diagrams

Recommended Vehicle Installation

For vehicle installations, Semtech recommends connecting the white Ignition Sense wire to the vehicle's ignition switch, as shown in the following illustration.

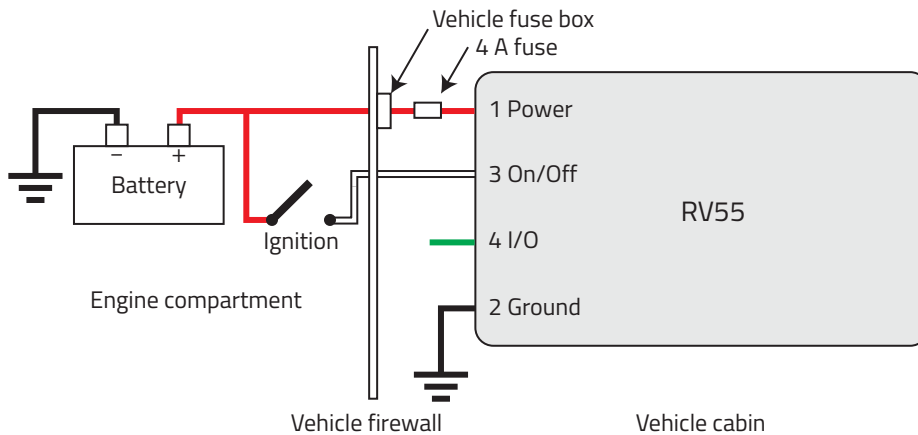

Figure 2-7: Recommended Vehicle Installation

The recommended vehicle installation allows the router to operate with the vehicle. When the vehicle ignition is off, the router is off. If desired, you can configure a delay between the time the vehicle's ignition shuts off, and the time the router shuts down. A delayed shutdown is especially useful if you want to maintain a network connection while the vehicle's engine is shut off for short periods, such as in a delivery vehicle.

- Pin 1 (Power) — Use the red wire in the DC cable to connect Pin 1 to the power source. Include a 4.0 A fast-acting fuse in the input power line. Semtech recommends using a continuous (unswitched) DC power source.
- Pin 2 (Ground) — Use the black wire in the DC cable to connect Pin 2 to ground. See also [Grounding the RV55 Router Chassis](#) on page 18.
- Pin 3 (Ignition Sense) — Semtech recommends always using the Ignition Sense wire (Pin 3) to turn the router off. It should not be turned off by disconnecting the power.

Alternate Vehicle Installation

The main difference between this installation and the standard vehicle installation is that you can configure a timer to turn the router on at set intervals for a configured length of time; for example 20 minutes once every 24 hours when the ignition is off. Also, instead of the router turning on and off, the router alternates between on and standby mode.

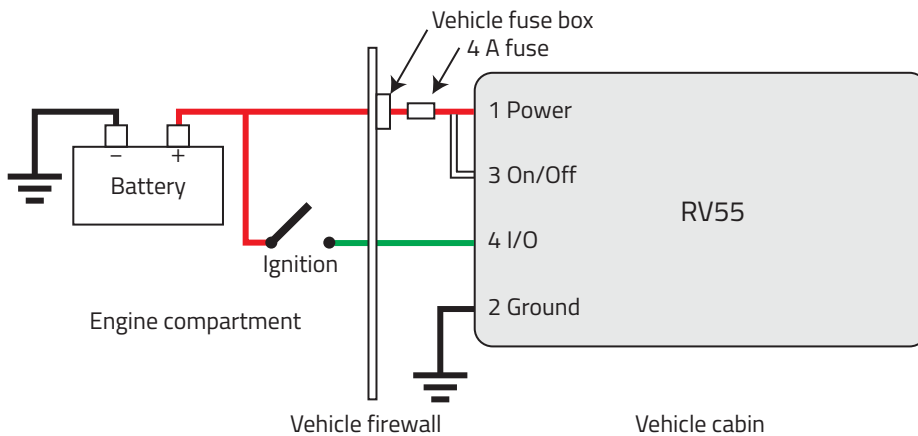

Figure 2-8: Alternate Vehicle Installation

- Pin 1 (Power) — Use the red wire in the DC cable to connect Pin 1 to the power source. Include a 4.0 A fast-acting fuse in the input power line. Semtech recommends using a continuous (unswitched) DC power source.
- Pin 2 (Ground) — Use the black wire in the DC cable to connect Pin 2 to ground. See also [Grounding the RV55 Router Chassis](#) on page 18.
- Pin 3 (Ignition Sense) — Connected to power
- Pin 4 (I/O) — Connected to ignition

Fixed Installation

For fixed installations, connect the wires as shown in the figure below. You can configure Low voltage disconnect to force the router into Standby mode when the voltage is low.

Note: When the router switches to Low Power mode based on a Low Voltage trigger, the voltage is monitored on the Red, Power wire.

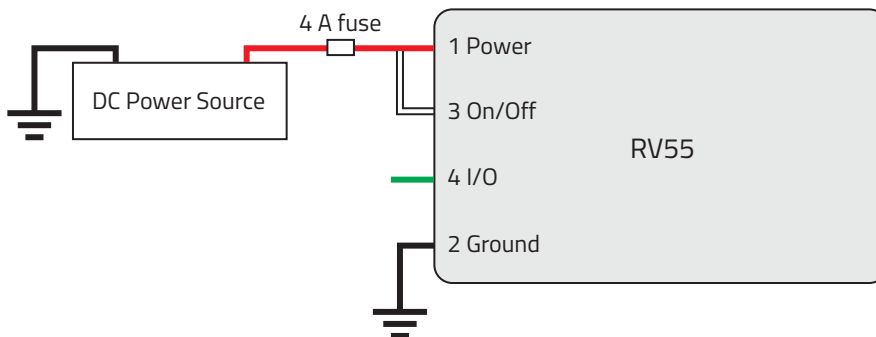

Figure 2-9: Fixed Installation without I/O

- Pin 1 (Power) — Use the red wire in the DC cable to connect Pin 1 to the power source. Include a 4.0 A fast-acting fuse in the input power line. Semtech recommends using a continuous (unswitched) DC power source.
- Pin 2 (Ground) — Use the black wire in the DC cable to connect Pin 2 to ground. See also [Grounding the RV55 Router Chassis](#) on page 18.
- Pin 3 (Ignition Sense) — Connected to power

Fixed Installation with I/O Input Triggered by Standby Mode

If you have a fixed installation where you want to use the I/O to monitor an external device such as a motion detector, remote solar panel, or a remote camera, refer to [Figure 2-10](#). You can configure the I/O line to wake the router up for a configured length of time, and use Low voltage disconnect to put the router in Standby mode if the voltage falls below a configured value.

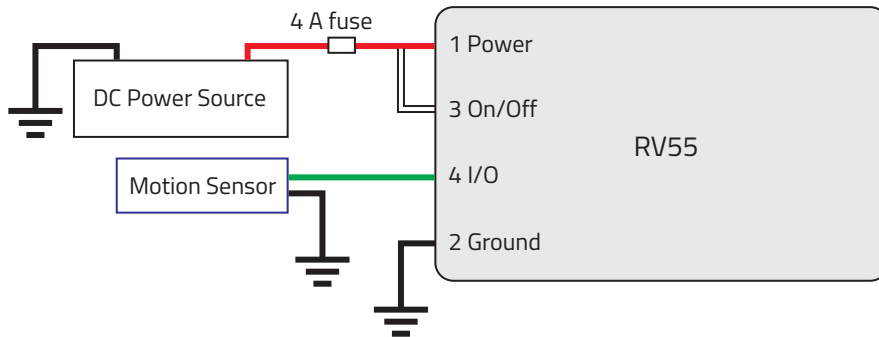

Figure 2-10: Fixed Installation with I/O

- Pin 1 (Power) — Use the red wire in the DC cable to connect Pin 1 to the power source. Include a 4.0 A fast-acting fuse in the input power line. Semtech recommends using a continuous (unswitched) DC power source.
- Pin 2 (Ground) — Use the black wire in the DC cable to connect Pin 2 to ground. See also [Grounding the RV55 Router Chassis](#) on page 18.
- Pin 3 (Ignition Sense) — Connected to power
- Pin 4 (GPIO) — Use the green wire for I/O configurations. See [I/O Configuration](#).

I/O Configuration

You can use the Pin 4 (GPIO) green wire as:

- A pulse counter
(See [Table 2-5](#) on page 29 and [Figure 2-11](#) on page 29.)
- A digital input
(See [Table 2-5](#) on page 29 and [Figure 2-12](#) on page 30.)
- A high side pull-up/dry contact switch input
(See [Table 2-7](#) on page 31 and [Figure 2-13](#) on page 31.)
- An analog input
(See [Table 2-8](#) on page 32 and [Figure 2-14](#) on page 32.)
- A low side current sink
(See [Table 2-9](#) on page 33 and [Figure 2-16](#) on page 33.)
- A digital output/open drain
(See [Table 2-10](#) on page 34 and [Figure 2-17](#) on page 34.)

For more information, refer to the ALEOS Software Configuration User Guide.

Note: You can configure the GPIO Pin 4 in ACManager or ALMS to trigger standby mode, to sink current, or to pull up the voltage. If you are using the I/O line to trigger standby mode, you cannot configure it to sink current or pull up the voltage. Likewise, if you are using the I/O line to either sink current or pull up the voltage, you cannot use it to trigger standby mode.

Note: During bootup, the I/O settings remain in their default state: the internal pull-up resistor is disabled, and output current sink switch is open. After bootup, any custom I/O settings are applied. This may take approximately 30 seconds after the router is restarted or powered on.

You can use Pin 4 in conjunction with events reporting to configure the RV55 router to send a report when the state of the monitored router changes, for example when a switch is opened or closed. For more information, refer to the ALEOS Software Configuration User Guide (Events Reporting chapter).

Pulse Counter

You can use the green wire to connect Pin 4 to a pulse counter. The digital pulse counter is not available in Standby mode.

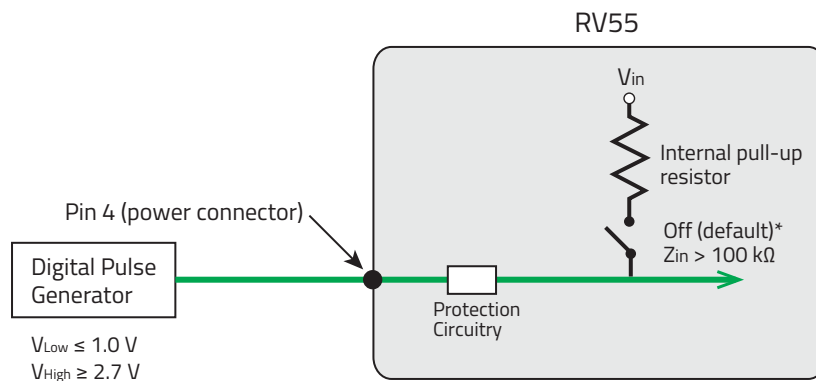

Figure 2-11: Digital Input / Pulse Counter

Note: Values may vary, depending on signal noise.

Table 2-5: Pulse Counter

Pull-up	State	Minimum	Typical	Maximum	Units
Off	Low	—	—	1.0	V
	High	2.7	—	V_{in}	V

Digital Input

You can use the green wire to connect Pin 4 to a digital input to detect the state of a switch such as a vehicle ignition, or to monitor an external device such as a motion detector, a remote solar panel, or a remote camera. Digital input can also be used with the standby timer.

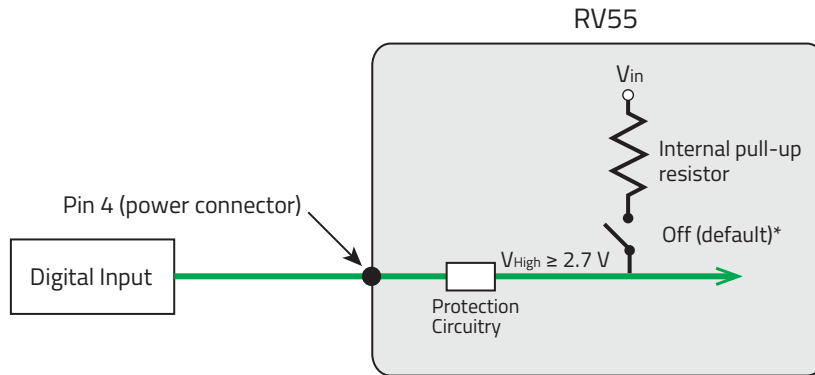

Figure 2-12: Digital Input

Table 2-6: Digital Input

Pull-up	State	Minimum	Typical	Maximum	Units
Off	Low	—	—	1.0	V
	High	2.7	—	V_{in}	V

High Side Pull-up / Dry Contact Switch Input

You can use the green wire to connect Pin 4 to a dry contact switch. The dry contact switch is not available in Standby mode.

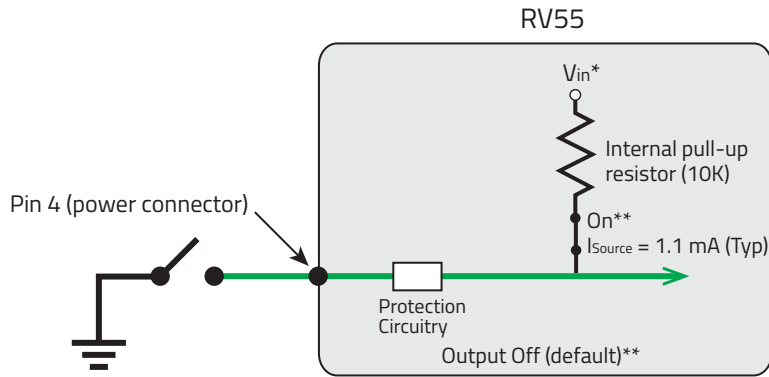

*Depending on the load, this value can range from V_{in} to $V_{in} - 2.5 \text{ V}$.

** Configurable on the ACEmanager I/O tab

Figure 2-13: High Side Pull-up / Dry Contact Switch Input

Table 2-7: High Side Pull-up / Dry Contact Switch Input

	Minimum	Typical	Maximum	Units	Comments
Source Current	0.6 $V_{in} = 7 \text{ V}$	1.1 $V_{in} = 12 \text{ V}$	3.5 $V_{in} = 36 \text{ V}$	mA	Maximum current the voltage output can provide (depends on V_{in})
V_{out}	$V_{in} - 2.5$	—	V_{in}	V	The voltage on Pin 4 when the high side pull-up is enabled (depends on V_{in} and power consumption)

Analog Input

You can use the green wire to connect Pin 4 to an analog sensor. As an analog input (voltage sensing pin), the router monitors voltage changes in small increments. This allows you to monitor equipment that reports status as an analog voltage.

Pin 4 detects inputs of 0.5–36 V referenced to ground. When used with a sensor to transform values into voltages, the pin can monitor measurements such as temperatures, sensors, or input voltage.

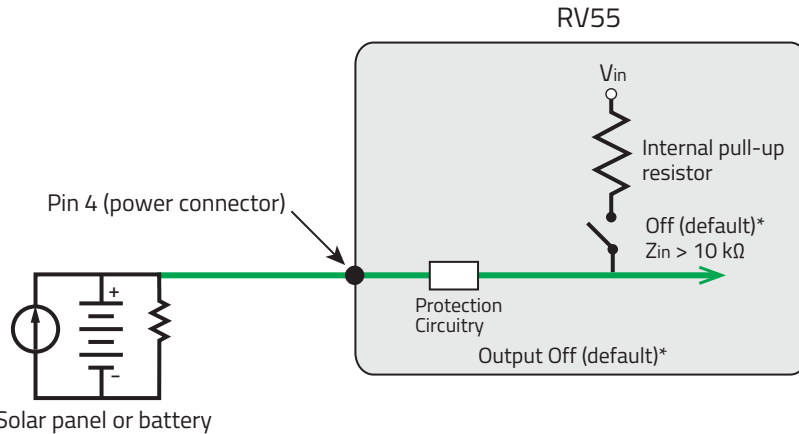

Figure 2-14: Analog Input

Table 2-8: Analog Input

Pull-up		Minimum	Typical	Maximum	Units	Comments
Off	Analog Input Range	0.5	—	36	V	—
	Analog Input Accuracy	-1.5%	0.50%	1.5%	—	—

Data sampling is handled by a dedicated microprocessor. In order to filter noisy signals, twenty measurements are taken over a 250 ms interval and they are averaged to generate a sample. If the change since the last sample is significant, a notification is sent to the CPU for updating the current value displayed in the user interface and for use by Events Reporting.

Changes are considered significant if the change is 150 mV or more. If there has not been a significant change to the parameter being monitored, the CPU reads a sample every 2.5 minutes, which detects small changes.

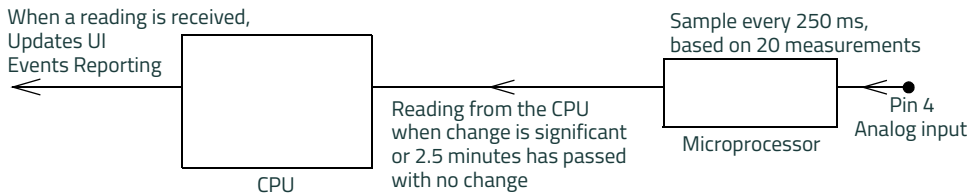
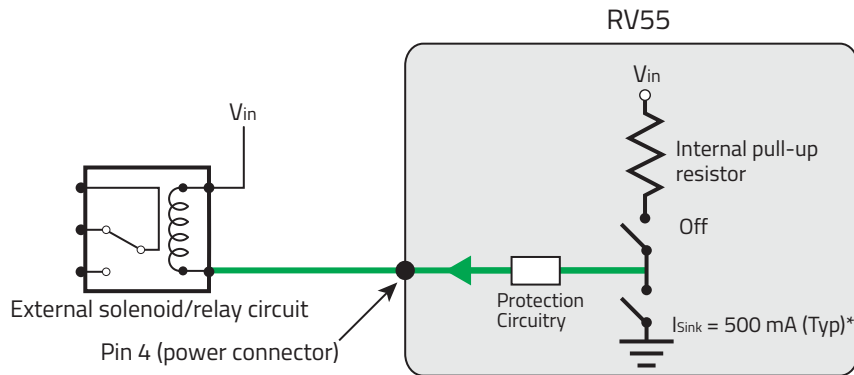

Figure 2-15: Analog Input Sampling and Reading

Note: The same method is used to sample the input voltage and the internal board temperature for Events Reporting. The significant changes are 300 mV for the input voltage and 1 °C for the board temperature.

Low Side Current Sink Output

You can use Pin 4 as a low side current sink, for example, to drive a relay.



* See Table 2-9 on page 33 for more details.

Figure 2-16: Low Side Current Sink

Table 2-9: Low Side Current Sink

Pull-up	State	Minimum	Typical	Maximum	Units	Comments
Off	On	250	500	1000	mA	$I_{\text{Typical}} = 25^{\circ}\text{C}$ $I_{\text{Min}} = 70^{\circ}\text{C}$ $I_{\text{Max}} = -40^{\circ}\text{C}$
Off	Off	—	0	—	mA	$V_{in} = 12$

Note: The router protection circuitry has a high-impedance ($\sim 125 \text{ k}\Omega$) path to ground. If Pin 4 is connected to 12 V, there will be a small current flow ($\sim 100 \mu\text{A}$) into Pin 4 during bootup. This flow is countered when the internal pull-up resistor ($10 \text{ k}\Omega$) becomes active after bootup. Depending on your application, you may need to install an external pull-up resistor ($10 \text{ k}\Omega$) in order to nullify the small input current flow for the first 30 seconds during bootup.

Digital Output/Open Drain

You can use Pin 4 as an open drain to drive an external digital input

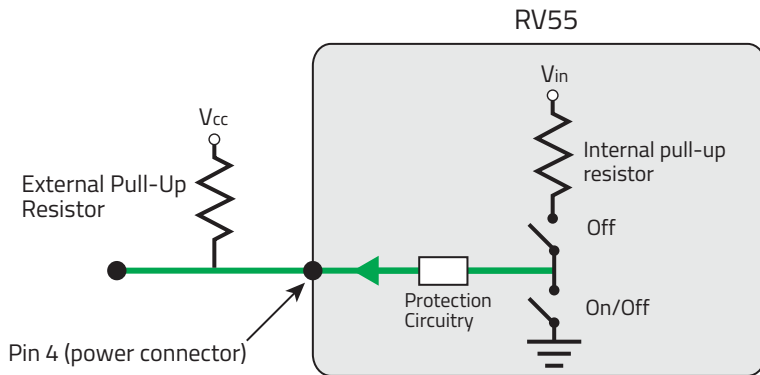

Figure 2-17: Digital Output/Open Drain

Table 2-10: Digital Output / Open Drain

Pull-up	State	Minimum	Typical	Maximum	Units	Comments
Off	Off	Open Circuit	—	—	—	—
	Active Low	—	—	0.5	V	5 mA, ≤ 5 V

Step 6 — Check the Router Operation

- When power is supplied to the AirLink RV55 router, it powers up automatically, as indicated by the flashing LEDs. If it does not turn on, ensure that the:
 - Power connector is plugged in and supplying voltage between 7 – 36 V.

Note: Although the RV55 router operates in the range 7–36 V, low voltage standby mode is enabled by default, so in order to avoid the router powering into standby mode, ensure that it is supplied with more than 9 V at startup. (If desired, you can change the low voltage standby settings once the router is operational.) If the Power LED is red, the router is in standby mode.



- Ignition Sense (pin 3) is connected to the battery or power source (see [Step 5 — Connect the Power](#) on page 22 for details)

LED Behavior





Figure 2-18: LED location

Table 2-11: LED Behavior

LED	Color / Pattern	Description	LED Power Saving Mode ^a
Power 	Off	No power or input voltage ≥ 36 VDC or ≤ 7 VDC	
	Solid Green	Power is present.	
	Green with Amber Flash	Power is present and the router has a GPS fix.	
	Solid Red	Standby mode	
	Flashing Green	When you press the reset button, flashing green indicates when to release the reset button to reboot the router.	
	Flashing Red	When you press the reset button, flashing red indicates when to release the reset button to reset the router to the factory default settings.	
	Flashing Amber	When you press the reset button for more than 20 seconds, flashing amber indicates when to release the reset button to enter Recovery mode. (See Recovery Mode on page 39.)	
Signal 	Solid Green	Good signal (equivalent to 3 – 5 bars)	Off
	Solid Amber	Fair signal (equivalent to 2 bars)	Off
	Flashing Amber	Poor signal (equivalent to 1 bar) If possible, Semtech recommends moving the router to a location with a better signal.	
	Flashing Red	Inadequate (equivalent to 0 bars) Semtech recommends moving the router to a location with a better signal.	

Note: The quality of the signal strength is measured using the appropriate parameters for the radio technology in use.

Table 2-11: LED Behavior

LED	Color / Pattern	Description	LED Power Saving Mode ^a
Network 	Solid Green	Connected to an LTE network	Off
	Solid Amber	Connected to a 3G or 2G network	Off
	Flashing Green	Connecting to the network	
	Flashing Green (3 sec. on/1 sec. off)	Network Ready—WAN over Wi-Fi (router is in Wi-Fi client mode)	
	Flashing Red	No network available	
	Flashing Red / Amber	Network Operator Switching is enabled, but the router is unable to locate the required firmware. For more information, refer to the ALEOS Software Configuration User Guide (Admin chapter).	
Activity 	Flashing Green	Traffic is being transmitted or received over the WAN interface.	
	Flashing Red	Traffic is being transmitted or received over the serial port. This behavior only appears if the RV55 router is configured to display it. For more information, refer to the ALEOS Software Configuration Guide (Serial chapter).	
	Flashing Amber	Traffic is being transmitted or received over both the WAN interface and the serial port. This behavior only appears if the RV55 router is configured to display it. Refer to the ALEOS Software Configuration Guide (Serial chapter).	
ALL	Green LED chase	Radio module reconfiguration / firmware update or Network Operator Switching is in progress.	
	Amber LED chase	ALEOS software update is in progress.	
	Red LED chase	Recovery mode	

a. To configure LED Power Saving Mode, refer to the ALEOS Software Configuration User Guide (Services chapter).

Ethernet LEDs

The Ethernet connector has two LEDs that indicate speed and activity. When looking into the connector:

- Activity—The right LED is solid amber when a link is present and flashing amber when there is activity.
- Connection Speed—The left LED indicates the Ethernet connection speed:
 - Solid Green—1000 Mbps
 - Solid Amber—100 Mbps
 - Off—10 Mbps

Step 7 — Startup and Software Configuration

You can configure the ALEOS software on the RV55 router using:

- [ACEmanager](#) (browser-based application)
- [AirLink Management Service](#) (cloud-based application)
- [AirLink Mobility Manager \(AMM\)](#)
- [AT Commands](#)

Configuring with ACEmanager

To access ACEmanager:

1. Connect a laptop to the router with an Ethernet cable.
2. Launch your web browser and go to:
 - <https://192.168.13.31:9443> (ALEOS 4.14.0 and later)
 - <http://192.168.13.31:9191> (ALEOS 4.13.0 or previous)

Note: It takes the router 2–3 minutes to respond after power up.

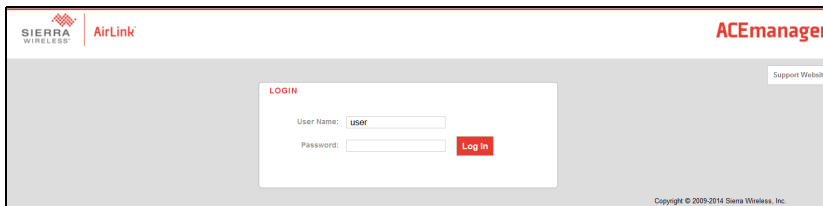

Figure 2-19: ACEmanager login window

3. Enter the default password (printed on the device label) and click Log In.

Note: For system security, ensure that you change the default password as soon as possible.

4. Refer to the ALEOS Software Configuration User Guide for information on how to use ACEmanager to configure your RV55 router.

Configuring with AirLink Management Service

AirLink Management Service (ALMS) allows remote management of all your routers from one user interface.

Some of its features include:

- Centralized, remote monitoring for all your AirLink routers and gateways
- Continuous status monitoring of important health data such as signal strength
- Location monitoring, including world map views
- Complete ALEOS reporting and configuration, including historical views of ALEOS information
- Configure individual routers and gateways or use templates to perform batch configurations of your AirLink devices
- Single click over-the-air firmware updates to all your routers and gateways
- Compatible with all carriers or mobile network operators

To get started, contact your Semtech Partner or visit www.sierrawireless.com/ALMS

Configuring with AMM

AirLink Mobility Manager (AMM) is a Network Management solution that provides a consolidated view of the entire vehicle fleet and enables simplified management, control and monitoring of connected AirLink routers. AMM is a licensed, unified software platform deployed in the enterprise data center. It enables:

- Mobile network and asset management
- Over-the-air registration, configuration and software updates
- Consolidated network view of an entire fleet, in-field applications and mobile assets, using a virtual dashboard to monitor, report, manage, and troubleshoot all mobile resources as required.

If you require a network management solution deployed in your data center, contact your Semtech sales representative for a demonstration of AMM capabilities.

Configuring with AT Commands

For a complete list of AT commands, refer to the ALEOS Software Configuration User Guide.

Reboot the RV55 Router

To reboot the RV55 router, use one of the following methods:

- On the router, press the Reset button for 1 – 5 seconds. (Release the button when the Power LED flashes green.)
- In ACEmanager, click the Reboot button on the toolbar.

Reset the RV55 Router to Factory Default Settings

To reset the router to the factory default settings:

- On the router, press the Reset button for more than 5 seconds. (Release the button when the Power LED flashes red.)
Once the LEDs resume their normal operating behavior, the reset is complete.
- In ACEmanager, go to Admin > Advanced and click the Reset to Factory Default button.

Tip: In ACEmanager, you can configure the RV55 router to preserve mobile network authentication settings such as the network ID, network password, custom APNs, Primary SIM, and Mobile Network Operator firmware when the router is reset to the factory default settings. For more details, refer to the ALEOS Software Configuration User Guide (Admin chapter).

Recovery Mode

If the router fails to boot properly, it automatically enters recovery mode, or, if the router is unresponsive to ACEmanager input and AT commands, you can manually put the router into recovery mode.

Recovery mode enables you to update the ALEOS software and return the router to working order. (For details, refer to the ALEOS Software Configuration User Guide — Configuring your router chapter.)

To enter Recovery mode manually:

- On the router, press the Reset button for more than 20 seconds. (Release the button when the Power LED flashes amber.)

To recover the router:

- Update ALEOS using the Recovery mode interface. Once the new ALEOS version is successfully uploaded and installed, the router reboots and exits recovery mode. When the process is complete, the ACEmanager login screen appears.

Note: After the recovery, you need to reload the radio module firmware store and templates.

To exit Recovery mode, if it has been inadvertently entered, do one of the following:

- Press the reset button on the router to reboot it.
- Click the Reboot button on the Recovery screen.
- Wait 10 minutes. If no action is taken within 10 minutes of the device entering Recovery mode (for example, if the Recovery screen has not been loaded by the web browser), it automatically reboots and exits Recovery mode.

For more information, refer to the ALEOS Software Configuration User Guide (Configuring your router chapter).

3: Specifications at a Glance

This chapter provides the specifications for the RV55 router.

Certification and Interoperability

Emissions / Immunity	<ul style="list-style-type: none"> FCC Industry Canada
Safety	<ul style="list-style-type: none"> CB Scheme UL 62368-1
Industry Certification for Vehicles	<ul style="list-style-type: none"> E-Mark (UN ECE Regulation 10.04), ISO7637-2 SAE J1455 (Shock & Vibration)
Environmental Compliance	<ul style="list-style-type: none"> RoHS 2011/65/EU (RoHS 2) WEEE REACH Halogen-free PCB
GSM/UMTS Certifications	<ul style="list-style-type: none"> PTCRB GCF-CC RED

Environmental Testing

Test Method	Category	Description
MIL-STD-810G, Test method 514.6 IEC 60068-2-64	Vibration	Frequency range: 10 Hz–150 Hz Spectrum level: 2.24G on all axes for 8 hours/axis Operating mode: powered on
MIL-STD-810G, Test method 516.6	Mechanical Shock	Half-sine 40G, 15–23 ms, (+/-X, +/-Y, +/-Z directions, 10 times per axis) Operating mode: powered on
MIL-STD-810G, Test methods 501.5, 502.5	Temperature	Rugged category: -30 °C to 70 °C 2-hour soak each temp high/low 3 cycles ramp <= 3 °C/minute Operating mode: powered on
MIL-STD-810G, Test methods 501.5, 502.5	Temperature	Rugged category: -40 °C to 85 °C 2-hour soak each temp high/low 50 cycles ramp <= 3 °C/minute Operating mode: unpowered

Test Method	Category	Description
MIL-STD-810G, Test method 507.5	Humidity	10 × 48-hour cycles: <ul style="list-style-type: none"> 4-hour ramp to 60 °C (95% humidity), hold 8 hours 4-hour ramp down to 30 °C (85% to 95% relative humidity), hold 21 hours 1-hour ramp down to 20 °C, hold 4 hours 1-hour ramp up to 30 °C, hold 5 hours Operating mode: powered on
IEC 60529	Water Resistance	Subject to spraying water. Water sprayed at an angle up to 60° on either side of the vertical for 10 minutes. Operating mode: unpowered
IEC 61000-4-2	Electrostatic Discharge	+/-8 kV (Contact), +/- 15 kV (Air) +/- 15 kV (Air at antenna connector) Operating mode: powered on
IEC 60068-2-32	Free Fall Test	1 m drop height 6 drops onto concrete, 2 per axis: X, Y, Z Operating mode: unpowered
IEC 60068-2-70 Part 2, Test Xb	Marking	The markings are rubbed with water for 10 cycles, then with lubricating oil for 10 cycles. Operating mode: unpowered
ISTA 2A 2001, test categories 1, 4, 5, & 6	Package	In shipping packaging. Cargo vibration and drop test.
IP rating	IP64 (see page 16)	

Reliability Specifications

The RV55 router has verified MTBF (Ground Benign, 30°C) as follows:

Part Number(s)	Description	Radio Module	MTBF (Years)
1104335	RV55 LTE North America	WP7610	127.4343832
1104303, 1105183	RV55 LTE-A Pro North America	EM7511	114.1037803
1104302, 1105186	RV55 LTE-A Pro Wi-Fi North America	EM7511	107.9600053
1104337	RV55 LTE EMEA	WP7607	118.6061531
1104332	RV55 LTE-A Pro Global	EM7565	113.9621611
1104331	RV55 LTE-A Pro Wi-Fi Global	EM7565	107.8332032

MTBF calculations are performed per:

- Telcordia “Reliability Prediction Procedure for Electronic Equipment” document number SR-332, Method 1, Issue 3

Included Radio Module Firmware

For carrier certification, please see the specifications at sierrawireless.com.

RV55 LTE NA:

- Sierra (default)
- Generic
- AT&T
- Verizon

RV55 LTE EMEA:

- Sierra (default)
- Generic

RV55 LTE-A Pro NA:

- Generic (default)
- AT&T (FirstNet with Carrier Aggregation)
- Sprint
- Verizon
- Sierra
- Bell

RV55 LTE-A Pro Global:

- Generic (default)
- Telstra
- Sierra

Host Interfaces

Antenna connectors	<ul style="list-style-type: none"> ▪ Base Cat 4/6/12 model: <ul style="list-style-type: none"> • Cellular (LTE) SMA • LTE Diversity • Active GPS ▪ Wi-Fi Cat 4/6/12 model: <ul style="list-style-type: none"> • Cellular (LTE) SMA • LTE Diversity • Active GPS • Wi-Fi × 2
USB	<hr/> <p><i>Note: Do not use the USB port in a potentially explosive environment.</i></p> <hr/> <ul style="list-style-type: none"> ▪ USB 2.0 Micro-AB connector complies with USB Version 2.0 for high speed operation ▪ Can be configured to operate in one of two modes: <ul style="list-style-type: none"> • Virtual Ethernet Port: The RV55 behaves as if the PC were connected to an Ethernet port, allowing access to the Internet and the RV55's internal web server. This is the default setting. • Virtual Serial Port: The RV55 behaves as if it was connected to a standard serial port. The primary use of this interface is for the AT command line interface of ALEOS and for diagnostic access to the radio module. <p>By default, the USB port is configured as a virtual Ethernet port.</p> ▪ A Windows driver must be installed on the PC in order to support USB use. The drivers are available for download on Semtech' support web site: source.sierrawireless.com/resources/airlink/software_downloads/airlink_usb_driver/ ▪ The ALEOS Software Configuration User Guide contains the details of USB mode configuration and driver installation. ▪ Semtech recommends you: <ul style="list-style-type: none"> • Use a USB 2.0 cable • Connect directly to your computer for best throughput.

<p>Ethernet</p>	<ul style="list-style-type: none"> ▪ 10/100/1000 Base-T RJ-45 Ethernet ▪ IEEE 802.3 Ethernet specification for 1000 Mbps speed (Gigabit Ethernet) with fallback to 100 or 10 Mbps (Cat 5e or Cat 6 cable is required for Gigabit Ethernet) ▪ Auto-crossover support ▪ Auto-negotiation detects the speed of the connecting device
<p>Serial Port</p>	<ul style="list-style-type: none"> ▪ 9-pin RS232 serial port connects directly to most computers or other devices with a standard serial straight-through cable <hr/> <p><i>Note: If you have a DCE device, you need to use a null modem (cross-over) cable.</i></p> <hr/> <ul style="list-style-type: none"> ▪ Operational as single 8-wire serial port or 2 × 4-wire serial port (requires a DB9 Y cable) <ul style="list-style-type: none"> • For pin-out information, see Serial Port on page 21 ▪ Used for connecting serial devices and configuration ▪ Complies with the EIA RS232D specification for DCE equipment ▪ Output driver levels swing from -7 VDC to +7 VDC with normal loading

SIM Card Interface

- The RV55 has two 6-pin SIM sockets for a mini-SIM (2FF) SIM cards, operated at 1.8 V/3.3 V.
- This interface is compliant with the applicable 3GPP standards for USIM.

Operating Voltage

By default, the router is configured to enter Standby mode at 9 V. If you want to operate the router at less than 9 volts, power it on using at least 9 V, launch ACEmanager, go to Services > Power Management and adjust the Standby mode settings.

The maximum ripple voltage to guarantee analog input accuracy must be 100 mVpp.

Power Specifications

Table 3-1: Power Supply Specifications

Pin	Name	Specification	Parameter	Minimum	Maximum
1	VCC	Voltage range	VCC	7 V	36 V

Table 3-2: Ignition Sense Specifications

Pin	Name	Input Impedance (Typ)	Specification	Parameter	Minimum	Maximum
3	IS (Input only)	80 k Ω (minimum)	Input low state voltage (maximum)	V_{IL}	—	1.0 V
			Input high state voltage (minimum guaranteed)	V_{IH}	3.3 V	V_{in}

*Note: If you do not connect this pin to the ignition, you **MUST** connect it to the positive terminal of your power supply or battery. The device looks for a qualified voltage on this pin as part of the power up sequence. If it doesn't see it, the device will not turn on. If you are using a Semtech AC power adapter, the connection is inside the cable.*

GNSS Technology

Satellite channels	LTE-A Pro: Maximum 30 tracking channels and 2 fast acquisition channels LTE: Maximum 48 tracking channels and 2 fast acquisition channels
Constellations	<ul style="list-style-type: none"> ▪ GPS ▪ GLONASS ▪ Galileo (LTE only) ▪ BeiDou (LTE only)
Protocol	NMEA 0183 V3.0

Acquisition time (Time to first fix)	<ul style="list-style-type: none"> ▪ Hot start: 1 second ▪ Cold start: 30 seconds
Sensitivity	Indoor sensitivity (tracking mode): <ul style="list-style-type: none"> ▪ -160 dBm (LTE-A Pro) ▪ -162 dBm (LTE)

Table 3-3: GNSS DC Bias Voltage

Signal	Description	Current/Voltage		
		Minimum	Typical	Maximum
GNSS Signal	Active bias on GNSS port	50 mA	75 mA	100 mA
	Maximum voltage output at 75 mA	—	—	3.3 V

GNSS Bands supported

Table 3-4: RV55 LTE-A Pro GNSS Bands Supported

Band	Frequency
GPS	1575.42 MHz
GLONASS	1602 MHz

Table 3-5: RV55 LTE GNSS Bands Supported

Band	Frequency
GPS	1575.42 MHz
GLONASS	1597.52–1605.92 MHz

Protocols

- Network: TCP/IP, UDP/IP, DNS
- Routing: NAT, Host Port Routing, DHCP, PPPoE, VLAN, VRRP, Reliable Static Route
- Applications: SMS, Telnet/SSH, Reverse Telnet, SMTP, SNMP, SNTP
- Serial: TCP/UDP PAD mode, Modbus (ASCII, RTU, Variable), PPP
- GNSS: NMEA 0183 V3.0, TAIP, RAP, Xora

Wi-Fi Performance

Technology	Frequency	MIMO	20 MHz ^a	40 MHz ^a	80 MHz ^a
802.11n	2.4 GHz	1 × 1	72 Mbps		
	5 GHz	1 × 1	100 Mbps	150 Mbps	
802.11ac	5 GHz	1 × 1	87 Mbps	200 Mbps	433 Mbps

a. Theoretical maximum performance. Actual data rates vary.

Wi-Fi Channels Supported

Note: By default, ALEOS enables all supported Wi-Fi channels. You can set the number of enabled Wi-Fi channels in ACEmanager or ALMS using the Wi-Fi Country Code setting. The default Country Code is United States. All other Country Code settings configure a subset of channels; they do not enable channels beyond those available in the default setting.

	Channel	Frequency (GHz)	20 MHz	40 MHz	80 MHz
2.4 GHz	1	2.412	✓		
	2	2.417	✓		
	3	2.422	✓		
	4	2.427	✓		
	5	2.432	✓		
	6	2.437	✓		
	7	2.442	✓		
	8	2.447	✓		
	9	2.452	✓		
	10	2.457	✓		
	11	2.462	✓		

	Channel	Frequency (GHz)	20 MHz	40 MHz	80 MHz
5 GHz	36	5.180	✓	✓	✓
	40	5.200	✓	✓	✓
	44	5.220	✓	✓	✓
	48	5.240	✓	✓	✓
	149	5.745	✓	✓	✓
	153	5.765	✓	✓	✓
	157	5.785	✓	✓	✓
	161	5.805	✓	✓	✓
	165	5.825	✓		

Wi-Fi Antenna Gain

The AirLink RV55 is compliant with the RF exposure requirements at 20 cm separation distance specified in EN 62311:2008 and 1999/519/EC for mobile exposure conditions, provided the maximum antenna gain does not exceed the limits given in the table below.

Table 3-6: Maximum Wi-Fi Antenna Gain

Frequency Band	Maximum Antenna Gain
2.4 GHz	3.25 dBi
5 GHz	5 dBi

Radio Frequency Bands

Use the following table as a guide to the radio frequencies and transmit power supported by the RV55 radio modules.

To determine which radio module your router has, refer to the label on the bottom of the router, or in ACEmanager, go to Status > About, and check the Radio Module Type field.

	RV55 LTE-A Pro		RV55 LTE	
Radio Module	EM7511	EM7565	WP7610	WP7607
Radio Frequency Bands	Table 3-7	Table 3-9	Table 3-13	Table 3-11
Radio Module Transmit Power	Table 3-8	Table 3-10	Table 3-14	Table 3-12
GNSS Technology / GNSS Bands Supported	Table 3-4		Table 3-5	

Table 3-7: RV55 LTE-A Pro Radio Module EM7511 North America

Radio Technology	SKU			Band	Frequencies
	Generic	Verizon Wireless	AT&T		
LTE	✓		✓	Band 1	Tx: 1920–1980 MHz Rx: 2110–2170 MHz
	✓	✓	✓	Band 2	Tx: 1850–1910 MHz Rx: 1930–1990 MHz
	✓		✓	Band 3	Tx: 1710–1785 MHz Rx: 1805–1880 MHz
	✓	✓	✓	Band 4	Tx: 1710–1755 MHz Rx: 2110–2155 MHz
	✓	✓	✓	Band 5	Tx: 824–849 MHz Rx: 869–894 MHz
	✓		✓	Band 7	Tx: 2500–2570 MHz Rx: 2620–2690 MHz
	✓		✓	Band 8	Tx: 880–915 MHz Rx: 925–960 MHz
	✓		✓	Band 9	Tx: 1749.9–1784.9 MHz Rx: 1844.9–1879.9 MHz
	✓		✓	Band 12	Tx: 699–716 MHz Rx: 729–746 MHz
	✓	✓	✓	Band 13	Tx: 777–787 MHz Rx: 746–756 MHz

Table 3-7: RV55 LTE-A Pro Radio Module EM7511 North America (Continued)

Radio Technology	SKU			Band	Frequencies
	Generic	Verizon Wireless	AT&T		
	✓		✓	Band 14	Tx: 788–798 MHz Rx: 758–768 MHz
	✓		✓	Band 18	Tx: 815–830 MHz Rx: 860–875 MHz
	✓		✓	Band 19	Tx: 830–845 MHz Rx: 875–890 MHz
	✓		✓	Band 20	Tx: 832–862 MHz Rx: 791–821 MHz
	✓		✓	Band 26	Tx: 814–849 MHz Rx: 859–894 MHz
	✓		✓	Band 29	Tx: n/a Rx: 717–728 MHz
	✓			Band 30	Tx: n/a Rx: 2350–2360 MHz
	✓		✓	Band 32	Tx: n/a Rx: 1452–1496 MHz
	✓		✓	Band 41	2496–2690 MHz (TDD)
	✓		✓	Band 42	3400–3600 MHz (TDD)
	✓		✓	Band 43	3600–3800 MHz (TDD)
	✓		✓	Band 46	5150–5925 MHz (TDD)
	✓		✓	Band 48	3550–3700 MHz (TDD)
	✓	✓	✓	Band 66	Tx: 1710–1780 MHz
HSPA	✓	✓	✓	Band 1	Tx: 1920–1980 MHz Rx: 2110–2170 MHz
	✓	✓	✓	Band 2	Tx: 1850–1910 MHz Rx: 1930–1990 MHz
	✓	✓	✓	Band 4	Tx: 1710–1755 MHz Rx: 2110–2155 MHz
	✓	✓	✓	Band 5	Tx: 824–849 MHz Rx: 869–894 MHz
	✓	✓	✓	Band 6	Tx: 830–840 MHz Rx: 875–885 MHz
	✓	✓	✓	Band 8	Tx: 880–915 MHz Rx: 925–960 MHz

Table 3-7: RV55 LTE-A Pro Radio Module EM7511 North America (Continued)

Radio Technology	SKU			Band	Frequencies
	Generic	Verizon Wireless	AT&T		
	✓	✓	✓	Band 9	Tx: 1749.9–1784.9 MHz Rx: 1844.9–1879.9 MHz
	✓	✓	✓	Band 19	Tx: 830–845 MHz Rx: 875–890 MHz

Table 3-8: Radio Module EM7511 Conducted Transmit Power

Band	Conducted Tx Power (dBm)	Notes
LTE		
Band 1 Band 2 Band 3 Band 4 Band 5 Band 8 Band 9 Band 12	Band 13 Band 14 Band 18 Band 19 Band 20 Band 26 Band 30 Band 66	+23±1
Band 7 Band 41	Band 42 Band 43 Band 48	+22±1
UMTS		
Band 1 (IMT 2100 12.2 kbps) Band 2 (UMTS 1900 12.2 kbps) Band 4 (AWS 1700/2100 12.2 kbps) Band 5 (UMTS 850 12.2 kbps) Band 6 (UMTS 800 12.2 kbps) Band 8 (UMTS 900 12.2 kbps) Band 9 (UMTS 1700 12.2 kbps) Band 19 (UMTS 800 12.2 kbps)	+23±1	Connectorized (Class 3)

Table 3-9: RV55 LTE-A Pro Radio Module EM7565 Global

Radio Technology	SKU	Band	Frequencies
	Generic		
LTE	✓	Band 1	Tx: 1920–1980 MHz Rx: 2110–2170 MHz
	✓	Band 2	Tx: 1850–1910 MHz Rx: 1930–1990 MHz
	✓	Band 3	Tx: 1710–1785 MHz Rx: 1805–1880 MHz
	✓	Band 4	Tx: 1710–1755 MHz Rx: 2110–2155 MHz
	✓	Band 5	Tx: 824–849 MHz Rx: 869–894 MHz
	✓	Band 7	Tx: 2500–2570 MHz Rx: 2620–2690 MHz
	✓	Band 8	Tx: 880–915 MHz Rx: 925–960 MHz
	✓	Band 9	Tx: 1749.9–1784.9 MHz Rx: 1844.9–1879.9 MHz
	✓	Band 12	Tx: 699–716 MHz Rx: 729–746 MHz
	✓	Band 13	Tx: 777–787 MHz Rx: 746–756 MHz
	✓	Band 18	Tx: 815–830 MHz Rx: 860–875 MHz
	✓	Band 19	Tx: 830–845 MHz Rx: 875–890 MHz
	✓	Band 20	Tx: 832–862 MHz Rx: 791–821 MHz
	✓	Band 26	Tx: 814–849 MHz Rx: 859–894 MHz
	✓	Band 28	Tx: 703–748 MHz Rx: 758–803 MHz
	✓	Band 29	Tx: n/a Rx: 717–728 MHz
✓	Band 30	Tx: n/a Rx: 2350–2360 MHz	

Table 3-9: RV55 LTE-A Pro Radio Module EM7565 Global (Continued)

Radio Technology	SKU	Band	Frequencies
	Generic		
	✓	Band 32	Tx: n/a Rx: 1452 – 1496 MHz
	✓	Band 41	2496 – 2690 MHz (TDD)
	✓	Band 42	3400 – 3600 MHz (TDD)
	✓	Band 43	3600 – 3800 MHz (TDD)
	✓	Band 46	n/a
	✓	Band 48	3550 – 3700 MHz (TDD)
	✓	Band 66	Tx: 1710 – 1780 MHz
HSPA	✓	Band 1	Tx: 1920 – 1980 MHz Rx: 2110 – 2170 MHz
	✓	Band 2	Tx: 1850 – 1910 MHz Rx: 1930 – 1990 MHz
	✓	Band 4	Tx: 1710 – 1755 MHz Rx: 2110 – 2155 MHz
	✓	Band 5	Tx: 824 – 849 MHz Rx: 869 – 894 MHz
	✓	Band 6	Tx: 830 – 840 MHz Rx: 875 – 885 MHz
	✓	Band 8	Tx: 880 – 915 MHz Rx: 925 – 960 MHz
	✓	Band 9	Tx: 1749.9 – 1784.9 MHz Rx: 1844.9 – 1879.9 MHz
	✓	Band 19	Tx: 830 – 845 MHz Rx: 875 – 890 MHz

Table 3-10: Radio Module EM7565 Conducted Transmit Power

Band	Conducted Tx Power (dBm)	Notes
LTE		
Band 1 Band 13 Band 2 Band 18 Band 3 Band 19 Band 4 Band 20 Band 5 Band 26 Band 8 Band 28 Band 9 Band 30 Band 12 Band 66	+23±1	
Band 7 Band 42 Band 41 Band 43 Band 48	+22±1	
UMTS		
Band 1 (IMT 2100 12.2 kbps) Band 2 (UMTS 1900 12.2 kbps) Band 4 (AWS 1700/2100 12.2 kbps) Band 5 (UMTS 850 12.2 kbps) Band 6 (UMTS 800 12.2 kbps) Band 8 (UMTS 900 12.2 kbps) Band 9 (UMTS 1700 12.2 kbps) Band 19 (UMTS 800 12.2 kbps)	+23±1	Connectorized (Class 3)

Table 3-11: RV55 Radio Module WP7607 EMEA

Radio Technology	SKU	Band	Frequencies
	Generic		
LTE	✓	Band 1	Tx: 1920–1980 MHz Rx: 2110–2170 MHz
	✓	Band 3	Tx: 1710–1785 MHz Rx: 1805–1880 MHz
	✓	Band 7	Tx: 2500–2570 MHz Rx: 2620–2690 MHz
	✓	Band 8	Tx: 880–915 MHz Rx: 925–960 MHz
		Band 20	Tx: 832–862 MHz Rx: 791–821 MHz
		Band 28	Tx: 703–748 MHz Rx: 758–803 MHz
WCDMA	✓	Band 1	Tx: 1920–1980 MHz Rx: 2110–2170 MHz
	✓	Band 8	Tx: 880–915 MHz Rx: 925–960 MHz
GSM/GPRS/EDGE		E-GSM 900	Tx: 880–915 MHz Rx: 925–960 MHz
		DCS 1800	Tx: 1710–1785 MHz Rx: 1805–1880 MHz

Table 3-12: Radio Module WP7607 Conducted Transmit Power

Band	Conducted Tx Power (dBm)	Notes
LTE		
Bands 1, 3, 7, 8, 20, 28	+23±1	Connectorized (Class 3)
WCDMA		
Bands 1, 8	+23±1	Connectorized (Class 3)
GSM/GPRS/EDGE		
E-GSM 900	+33±1	GMSK mode (Class 4)
	+27±1	8PSK mode (Class E2)

Table 3-12: Radio Module WP7607 Conducted Transmit Power (Continued)

Band	Conducted Tx Power (dBm)	Notes
DCS 1800	+30±1	GMSK mode (Class 1)
	+26±1	8PSK mode (Class E2)

Table 3-13: RV55 Radio Module WP7610 North America

Radio Technology	SKU	Band	Frequencies
	Generic		
LTE	✓	Band 2	Tx: 1850 – 1910 MHz Rx: 1930 – 1990 MHz
	✓	Band 4	Tx: 1710 – 1755 MHz Rx: 2110 – 2155 MHz
	✓	Band 5	Tx: 824 – 849 MHz Rx: 869 – 894 MHz
	✓	Band 12	Tx: 699 – 716 MHz Rx: 729 – 746 MHz
	✓	Band 13	Tx: 777 – 787 MHz Rx: 746 – 756 MHz
		Band 14	Tx: 788 – 798 MHz Rx: 758 – 768 MHz
	✓	Band 17	Tx: 704 – 716 MHz Rx: 734 – 746 MHz
	✓	Band 66	Tx: 1710 – 1780 MHz Rx: 2110 – 2200 MHz
WCDMA	✓	Band 2	Tx: 1850 – 1910 MHz Rx: 1930 – 1990 MHz
	✓	Band 4	Tx: 1710 – 1755 MHz Rx: 2110 – 2155 MHz
	✓	Band 5	Tx: 824 – 849 MHz Rx: 869 – 894 MHz

Table 3-14: Radio Module WP7610 Conducted Transmit Power

Band	Conducted Tx Power (dBm)	Notes
LTE		
Bands 2, 4, 5, 12, 13, 17, 66	+23±1	Connectorized (Class 3)
WCDMA		
Bands 2, 4, 5	+23±2	Connectorized (Class 3)

Carrier Aggregation Combinations

LTE-Advanced uses carrier aggregation to increase bandwidth. The following tables show the carrier aggregation combinations.

Table 3-15: EM7511/7565 PTCRB Carrier Aggregation Downlink Combinations^a

1 Band / 2CC	1 Band / 3CC	2 Bands / 2CC	2 Bands / 3CC	3 Bands / 3CC
		1A-3A	1A-7A-7A	1A-3A-5A
		1A-5A		1A-3A-7A
		1A-7A		1A-3A-8A
		1A-18A		1A-3A-19A
		1A-19A		1A-3A-20A
		1A-20A		1A-5A-7A
		1A-26A		1A-7A-20A
		1A-41A		
2A-2A		2A-4A	2A-2A-5A	2A-4A-5A
2C		2A-7A	2A-2A-12A	2A-4A-7A
		2A-12A	2A-2A-13A	2A-4A-12A
		2A-13A	2A-7A-7A	2A-4A-13A
		2A-29A	2A-66A-66A	2A-4A-29A
		2A-30A	2A-66B	2A-12A-30A
		2A-46A	2A-66C	2A-13A-66A
		2A-66A		2A-29A-30A
3A-3A		3A-5A	3A-3A-7A	3A-7A-20A
3C		3A-7A	3C-5A	
		3A-8A	3A-7B	

Table 3-15: EM7511/7565 PTCRB Carrier Aggregation Downlink Combinations^a (Continued)

1 Band / 2CC	1 Band / 3CC	2 Bands / 2CC	2 Bands / 3CC	3 Bands / 3CC
		3A-19A	3A-7C	
		3A-20A	3A-7A-7A	
		3A-41A	3C-7A	
			3C-20A	
			3A-41C	
4A-4A		4A-5A	4A-4A-5A	4A-5A-30A
		4A-7A	4A-4A-12A	4A-7A-12A
		4A-12A	4A-4A-13A	4A-12A-30A
		4A-13A	4A-4A-30A	4A-29A-30A
		4A-29A	4A-7A-7A	
		4A-30A		
		4A-46A		
		5A-30A	5A-66C	5A-30A-66A
		5A-66A	5A-66A-66A	
7B		7A-12A		
7C		7A-20A		
		12A-30A		12A-30A-66A
		12A-66A		
		13A-66A	13A-66A-66A	
		13A-66B		
		20A-32A		
		29A-30A		29A-30A-66A
		29A-66A		
		30A-66A		
	41D			
66B	66A-66B			
66C	66A-66C			

a. Supported CA DL combinations outside of North America are carrier-dependent.

Table 3-16: EM7511/7565 Additional Carrier Aggregation Downlink Combinations^a

1 Band / 2CC	1 Band / 3CC	2 Bands / 2CC	2 Bands / 3CC	3 Bands / 3CC
		1A-8A	1A-42C	1A-3A-28A
		1A-42A		
		2A-5A		2A-5A-30A
		2A-28A		2A-5A-66A
				2A-7A-12A
		3A-28A	3A-42C	3A-41A-42A
		3A-42A		3A-7A-28A
		3C-28A		
		4A-28A		
5B		5A-7A		
		5A-46A		
		5A-66B		
7A-7A		7A-28A		
		7B-28A		
		7C-28A		
		13A-46A	13A-66C	
		19A-42A	19A-42C	
		28A-42A		
41C		41A_42A	41A-42C	
		41C-42A		
42C				
48A-48A			48A-48C	
48C				
	48D			

a. Supported CA DL combinations outside of North America are carrier-dependent.

Table 3-17: EM7511 LTE B14 Carrier Aggregation Downlink Combinations

2DLCA	3DLCA
2A_14A	2A_14A_30A
14A_30A	14A_30A_66A
14A_66A	2A_2A_14A

Table 3-17: EM7511 LTE B14 Carrier Aggregation Downlink Combinations

2DLCA	3DLCA
	2_14A_66A
	14_66A_66A

Table 3-18: EM7511/7565 Carrier Aggregation Uplink Combinations

3C
7C
41C

Mechanical Specifications

- Housing — The RV55 router is made of ruggedized powder-coated aluminum.
- RoHS — The RV55 router complies with the Restriction of Hazardous Substances Directive (RoHS). This directive restricts the use of six hazardous materials in the manufacture of various types of electronic and electrical equipment.

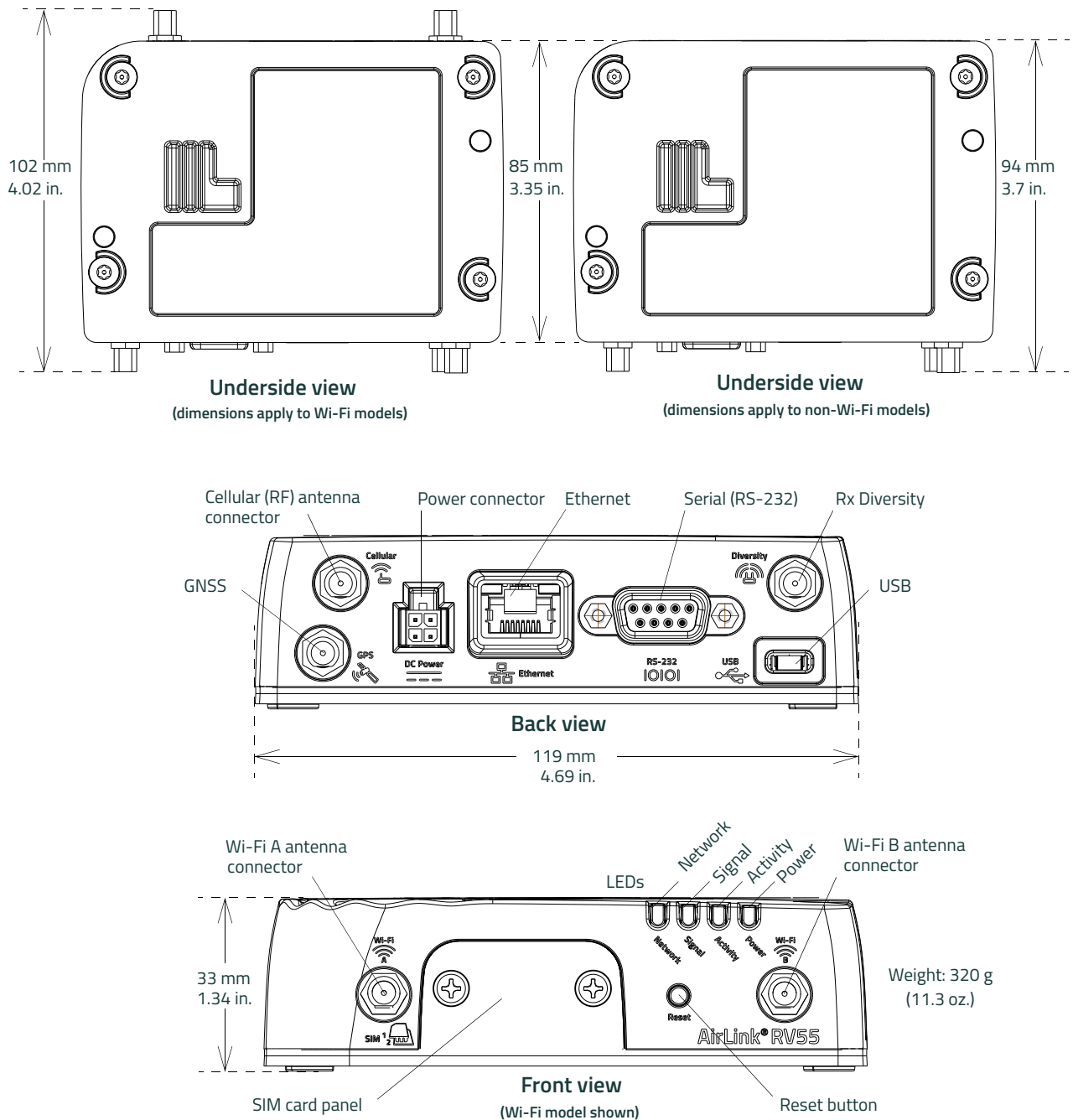

Figure 3-1: RV55 Router Mechanical Specifications

Screw Torque Settings

- DIN rail mount screws: 1.1 N-m (10 in-lb)
- Antennas: Finger tight (5–7 in-lb) is sufficient. The max torque should not go beyond 1.1 N-m (10 in-lb).

4: Regulatory Information

Important Information for North American Users

Note: This equipment has been tested and found to comply with the limits for a Class A digital device, pursuant to part 15 of the FCC Rules. These limits are designed to provide reasonable protection against harmful interference when the equipment is operated in a commercial environment. This equipment generates, uses, and can radiate radio frequency energy and, if not installed and used in accordance with the instruction manual, may cause harmful interference to radio communications. Operation of this equipment in a residential area is likely to cause harmful interference, in which case the user will be required to correct the interference at his own expense.

Warning: *Changes or modifications to this device not expressly approved by Sierra Wireless could void the user's authority to operate this equipment.*

RF Exposure

FCC

In accordance with FCC/IC requirements of human exposure to radio frequency fields, the radiating element shall be installed such that a minimum separation distance of 20 cm (8 inches) should be maintained from the antenna and the user's body.

Warning: *This product is only to be installed by qualified personnel.*

To comply with FCC/IC regulations limiting both maximum RF output power and human exposure to RF radiation, the maximum antenna gain must not exceed the specifications listed below for the device used.

Health Canada

To ensure that the AirLink router meets Health Canada's Safety Code 6 requirements, a separation distance of at least 20 cm (8 inches) must be maintained between the router's antenna and the body of the user and any nearby persons at all times and in all applications and uses.

Antennas used must not exceed the maximum allowable gain specified in this hardware user guide. See [Maximum Antenna Gain](#) on page 65.

Maximum Antenna Gain

The antenna gain must not exceed the limits and configurations shown in the following table:

Device	Frequency Band	Gain Limit (Standalone)	Gain Limit (Collocated)
AirLink RV55 (EM7511): N7NEM75S 2417C-EM75S	WCDMA Band 2/LTE B2	6 dBi	4 dBi
	WCDMA Band 4/LTE B4	6 dBi	4 dBi
	WCDMA Band 5/LTE B5	6 dBi	4 dBi
	Band 7	9 dBi	4 dBi
	Band 12	6 dBi	4 dBi
	Band 13	6 dBi	4 dBi
	Band 14	6 dBi	4 dBi
	Band 26	6 dBi	4 dBi
	Band 41	9 dBi	4 dBi
	Band 66	6 dBi	4 dBi
AirLink RV55 (EM7565): N7NEM75L 2417C-EM75L	WCDMA Band 2/LTE B2	6 dBi	4 dBi
	WCDMA Band 4/LTE B4	6 dBi	4 dBi
	WCDMA Band 5/LTE B5	6 dBi	4 dBi
	Band 7	9 dBi	4 dBi
	Band 12	6 dBi	4 dBi
	Band 13	6 dBi	4 dBi
	Band 26	6 dBi	4 dBi
	Band 30	6 dBi	4 dBi
	Band 41	9 dBi	4 dBi
	Band 66	6 dBi	4 dBi

EU

Semtech hereby declares the AirLink RV55 devices are in compliance with the essential requirements and other relevant provisions of Directive 2014/53/EU.

The RV55 devices display the CE mark.



Warning: Changes or modifications to this device not expressly approved by Semtech could void the user's authority to operate this equipment.

Warning: *This product is only to be installed by qualified personnel.*

Declaration of Conformity

The Declaration of Conformity made under Directive 2014/53/EU is available for viewing at:

source.sierrawireless.com/resources/airlink/certification_and_type_approval/RV55_ce_declaration_of_conformity/

Notice for Brazilian Users

Warning: *CISPR 22: This is a class A product. In a domestic environment this product may cause radio interference, in which case the user may be required to take adequate measures.*

Aviso: *CISPR 22: Este produto não é apropriado para uso em ambientes domésticos, pois poderá causar interferências eletromagnéticas que obrigam o usuário a tomar medidas necessárias para minimizar estas interferências.*

Este equipamento não tem direito à proteção contra interferência prejudicial e não pode causar interferência em sistemas devidamente autorizados

Para maiores informações, consulte o site da Anatel: www.gov.br/anatel/pt-br

IECEX Compliance

Special conditions of safe use:

- Equipment references the enclosure ground. The end user shall ensure that the installation adequately mitigates the risks of circulating earth currents and floating voltages.
- Equipment shall be installed in an Ex certified tool secured enclosure which provides a minimum ingress protection of IP54. It must be mounted with mounting screws on a flat surface, or optional DIN rail mounting bracket with the DIN rail clip to a horizontal DIN rail and the spring clip at the bottom.

This certification applies to the following Product SKUs:

- 1104302
- 1104303
- 1104331
- 1104332
- 1104335
- 1104337
- 1105183
- 1105186

Applicable standards

- EN IEC 60079-0:2017, Edition 7.0
- IEC 60079-7:2017, Edition 5.1
- EN 60079-0:2018
- EN 60079-7:2015 +A1:2018

Ex ec IIC T6 Gc

 II 3 G Ex ec IIC T6 Gc

- IECEx ETL 21.0024X
- ITS-I21ATEX29788X

WEEE Notice



If you purchased your AirLink RV55 device in Europe, please return it to your dealer or supplier at the end of its life. WEEE products may be recognized by their wheeled bin label on the product label.

A: Accessories

DC Power Cable (Black Connector)

Table A-1: DC Power Cable

DC Power Cable	
Part Number	2000522
Product Release	2016

Components:

- ❶ 1 UL2464 20 AWG × 4 core cable
- ❷ 4 Molex female crimp terminals /AWG 20-24, 250 V, 4 A Max, phosphor bronze tin-plated (part number 43030-0001)
- ❸ 1 Molex male 2×2P Ph: 3.0 mm housing, 250 V, 5 A max, PA65 black UL94V-0 (part number 43025-0408)

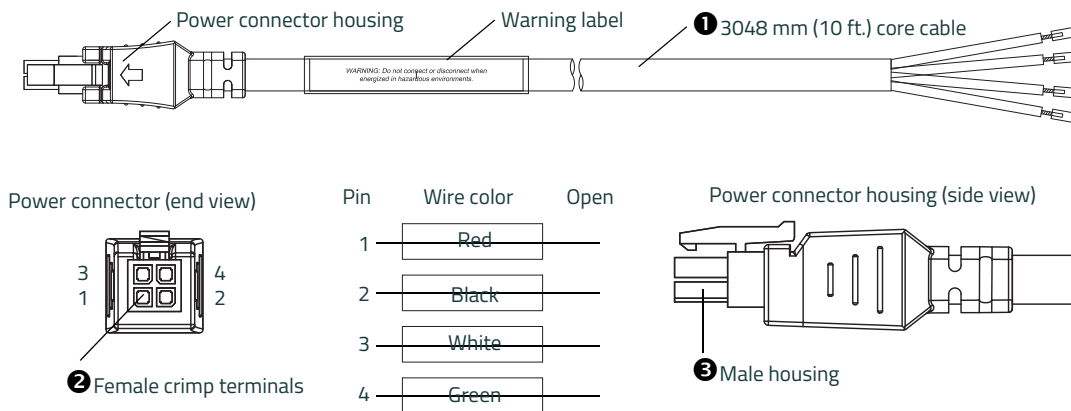

Figure A-1: DC Cable Specifications

AC Power Adapter (Black Connector)

Note: Please note that the AC power adapter is not available for sale in New Zealand (as of June 1, 2018).

AC Power Adapter	
Part Number	2000579
Product Release Date	2016

AC Power Adapter Input

Table A-2: Input Specifications

	Minimum	Typical	Maximum
Input			
Input Voltage	90 VAC	100–240 VAC	264 VAC
Input Frequency	47 Hz	50/60 Hz	63 Hz

*Note: Input voltage range is 90 VAC to 264 VAC.
Maximum input current is 500 mA at 100–240 VAC.
Inrush current will not exceed 75 A at 100–240 VAC input and maximum load from a cold start at 25°C.*

AC Power Adapter Output

Table A-3: AC Power Adapter Output Specifications

	Minimum	Typical	Maximum	Test conditions	
Output Voltage	—	11.4 VDC	12.0 VDC	12.6 VDC	0 ~ 1.5 A loading

AC Power Adapter Environmental Specifications

Table A-4: AC Power Adapter Environmental Specifications

Operating	
Operating Temperature	0°C ~ 40°C (operates normally)
Relative Humidity	10% ~ 90%
Altitude	Sea level to 2,000 meters
Vibration	1.0 mm, 10–55 Hz, 15 minutes per cycle for each axis (X, Y, Z)
Non-operating	
Storage Temperature	-30°C ~ 70°C
Relative Humidity	10% ~ 90%
Vibration and Shock	MIL-STD-810D, method 514

AC Power Adapter Reliability and Quality Control

AC Power Adapter MTBF

When the power supply is operating within the limits of this specification, the MTBF is at least 200,000 hours at 25°C (MIL-HDBK-217F).

Note: For router MTBF, see [Reliability Specifications](#) on page 54.

AC Power Adapter Safety Standards

The power supply is certified with the following international regulatory standards:

Table A-5: AC Power Adapter Safety Standards

Regulatory Agency	Country or Region	Certified	Standard
UL	USA	Approved	UL60950-1
GS	Europe	Approved	EN60950-1
CE	Europe	Approved	EN60950-1
SAA	Australia	Approved	AS/NZS 60950
CCC	China	Approved	GB4943
CUL	Canada	Approved	CSA C22.2 NO.60950-1

AC Power Adapter EMC Standards

The power supply meets the radiated and conducted emission requirements for EN55022, FCC Part 15, Class B, GB9254.

AC Power Adapter Hazardous Substances

- EU Directive 2011/65/EU “RoHS”
- EU Directive 2012/19/EU “WEEE”
- REACH

AC Power Adapter Energy Efficiency

The AC adapter complies with International Efficiency Levels, as shown in [Table A-6](#).

Table A-6: AC Adapter Energy Efficiency

Supplied Input	No-load power consumption	Average active mode efficiency	International Efficiency Level
115 VAC, 60 Hz	Less than 0.1 W	Greater than 85%	VI
230 VAC, 50 Hz	Less than 0.3 W	Greater than 80.4%	V

Dual Serial Port Adapter Cable

Table A-7: Dual Serial Port Adapter Cable

DC Power Cable	
Part Number	6001238
Product Release	2019

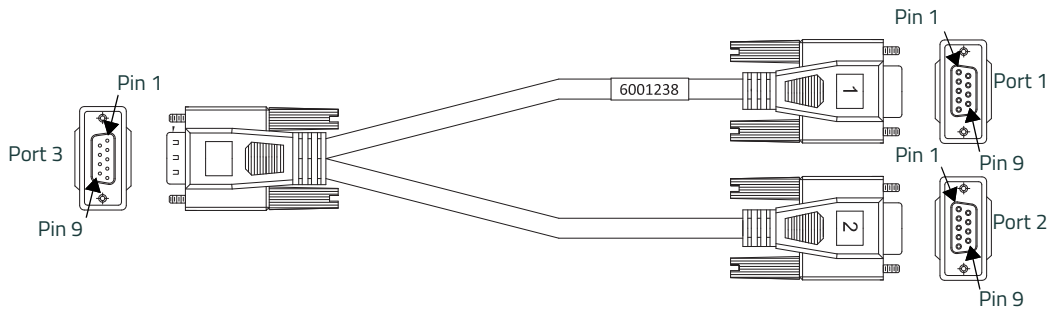

Table A-8: Serial Connector Pin Assignment

Description	Type	Port 3 Pin	Port 1 Pin	Port 2 Pin
Port 2 Clear To Send	OUT	1	—	8
Port 1 Transmit Data	OUT	2	2	—
Port 1 Receive Data	IN	3	3	—
Port 2 Receive Data	IN	4	—	3
Main GND. Connected internally to BOARD GND	GND	5	5	5
Port 2 Transmit Data	OUT	6	—	2
Port 1 Ready To Send	IN	7	7	—
Port 1 Clear To Send	OUT	8	8	—
Port 2 Ready To Send	IN	9	-	7

Index

A

- Accessories, [13](#)
- ACEmanager, [10](#), [37](#)
- AirLink Management Service, [10](#), [37](#)
- ALEOS software, [37](#)
- Analog input, [32](#)
- Antenna
 - Connecting, [18](#)
 - Maximum gain, [65](#)
 - Recommended separation, [20](#)
 - Safe mounting, [16](#)
- AT commands, [10](#), [38](#)

C

- Cable strain relief, [23](#)
- Cables, connecting, [20](#)
- Carrier aggregation, [58](#)
- Certification
 - Mobile Network Operator, [42](#)
- Communication
 - AT commands, using, [38](#)
- Configuring the gateway, [10](#)
 - AirLink Management Service, [37](#)
 - AT commands, [38](#)
- Current sink, [33](#)

D

- DC cable wires, [24](#)
- DC voltage transients, [23](#)
- Description, product, [8](#)
- Digital I/O specifications, [45](#)
- Digital output, [34](#)
- Dual SIM, [13](#)

E

- EM7511 radio module
 - Conducted transmit power, [52](#)
 - Frequency bands, [50](#)
- EM7565 radio module
 - Conducted transmit power, [55](#)
 - Frequency bands, [53](#)
- Ethernet
 - LEDs, [36](#)
 - Specification, [21](#)
- Ethernet, virtual Ethernet port, [21](#)

F

- Features, [8](#)
- Fusing, [23](#)

G

- GNSS, [45](#)
- GNSS, bands supported, [46](#)
- Grounding the chassis, [18](#)

H

- Host Interfaces, [43](#)

I

- I / O Configuration, [28](#)
- Input
 - Analog, [32](#)
 - Dry contact switch, [31](#)
 - Ignition switch, [30](#)
- Installation
 - Connect data cables, [20](#)
 - Connect power cable, [22](#)
 - Connecting antennas, [18](#)
 - Fixed (with I/O), [28](#)
 - Fixed (without I/O), [27](#)
 - Insert SIM cards, [15](#)
 - overview, [14](#)
 - Tools and materials required, [14](#)
 - Vehicle, [26](#)

L

- LED
 - Description of LED, [34](#)
 - Power Saving Mode, [35](#)

M

- Mounting
 - Brackets, [16](#)
 - DIN rail, [17](#)
 - kits, [17](#)
 - On DIN rail, [17](#)
- MTBF, [41](#)

N

- Network Operator Switching, [13](#)

O

- Open drain, [34](#)
- Operating voltage, [45](#)
- Output, digital, [34](#)

P

- Ports, [8](#)
- Power
 - Connecting, [22](#)
 - Connector, [22](#)
 - input specifications, [45](#)
 - Modes, [10](#)
 - power supply specifications, [45](#)
- Power consumption, sample scenarios, [12](#)
- Power saving features, [11](#)
- Protocols, [47](#)

Pull-up resistor, [31](#)

Pulse counter, [29](#)

R

Rebooting, [38](#)

Regulatory information, [64](#)

Regulatory specifications, [71](#)

Reliability, [41](#)

Reset to factory default settings, [38](#)

RF specifications, [18](#)

S

Screw Torque, [63](#)

Serial connector pin-out, [22](#), [72](#)

Serial port, [21](#), [44](#)

 Virtual serial port, [21](#)

SIM cards, insert, [15](#)

SIM, dual, [13](#)

Specifications, [40](#)

 Environmental, [40](#)

 GNSS, [45](#)

 Regulatory, [71](#)

 RF, [18](#)

Standards, regulatory, [71](#)

T

Tools required for install, [14](#)

U

USB, [21](#)

V

Vehicle installation

 Alternate, [26](#)

 Recommended, [26](#)

Virtual port, Ethernet or serial, [21](#)

Voltage, input and ripple range, [45](#)

W

Warranty, [13](#)

Wi-Fi performance, [47](#)

Wiring diagrams, [26](#)