



AirLink RX55

Hardware User Guide

Important Notice

Information relating to this product and the application or design described herein is believed to be reliable, however such information is provided as a guide only and Semtech assumes no liability for any errors in this document, or for the application or design described herein.

Semtech reserves the right to make changes to the product or this document at any time without notice. Buyers should obtain the latest relevant information before placing orders and should verify that such information is current and complete. Semtech warrants performance of its products to the specifications applicable at the time of sale, and all sales are made in accordance with Semtech's standard terms and conditions of sale.

SEMTECH PRODUCTS ARE NOT DESIGNED, INTENDED, AUTHORIZED OR WARRANTED TO BE SUITABLE FOR USE IN LIFE-SUPPORT APPLICATIONS, DEVICES OR SYSTEMS, OR IN NUCLEAR APPLICATIONS IN WHICH THE FAILURE COULD BE REASONABLY EXPECTED TO RESULT IN PERSONAL INJURY, LOSS OF LIFE OR SEVERE PROPERTY OR ENVIRONMENTAL DAMAGE. INCLUSION OF SEMTECH PRODUCTS IN SUCH APPLICATIONS IS UNDERSTOOD TO BE UNDERTAKEN SOLELY AT THE CUSTOMER'S OWN RISK. Should a customer purchase or use Semtech products for any such unauthorized application, the customer shall indemnify and hold Semtech and its officers, employees, subsidiaries, affiliates, and distributors harmless against all claims, costs damages and attorney fees which could arise.

The Semtech name and logo are registered trademarks of the Semtech Corporation. All other trademarks and trade names mentioned may be marks and names of Semtech or their respective companies. Semtech reserves the right to make changes to, or discontinue any products described in this document without further notice. Semtech makes no warranty, representation or guarantee, express or implied, regarding the suitability of its products for any particular purpose. All rights reserved.

Wireless Communications

Due to the nature of wireless communications, transmission and reception of data can never be guaranteed. Data may be delayed, corrupted (i.e., have errors) or be totally lost. The Semtech product should not be used in situations where failure to transmit or receive data could result in damage of any kind to the user or any other party, including but not limited to personal injury, death, or loss of property. Semtech accepts no responsibility for damages of any kind resulting from delays or errors in data transmitted or received using the Semtech product, or for failure of the Semtech product to transmit or receive such data.

Warranty

Warranty information for AirLink products is available at www.sierrawireless.com/end-user-warranty.

Safety

Do not operate the Semtech product in areas where blasting is in progress, where explosive atmospheres may be present, near medical equipment, near life support equipment, or near any equipment which may be susceptible to any form of radio interference. In such areas, the Semtech product should be powered off.

The driver or operator of any vehicle should not operate the Semtech product while in control of a vehicle. Doing so will detract from the driver or operator's control and operation of that vehicle. In some states and provinces, operating such communications devices while in control of a vehicle is an offence.

The RX55 platform is classified to ANSI/ISA 12.12.01-2016 and CSA C22.2#213 and are suitable for use in Class 1, Division 2, Groups A, B, C and D T6, and Class I Zone 2 Group IIC T6 classified Hazardous Locations.

The following warnings and instructions apply:

Warning: *EXPLOSION HAZARD—SUBSTITUTION OF COMPONENTS MAY IMPAIR SUITABILITY FOR CLASS I, DIVISION 2 and CLASS I, ZONE 2.*

Warning: *EXPLOSION HAZARD—DO NOT DISCONNECT WHILE CIRCUIT IS LIVE UNLESS THE AREA IS KNOWN TO BE NON-HAZARDOUS.*

Warning: *DO NOT USE THE USB CONNECTOR IN A HAZARDOUS AREA.*

Avertissement: *RISQUE D'EXPLOSION—LA SUBSTITUTION DE COMPOSANTS PEUT RENDRE CE MATERIEL INACCEPTABLE POUR LES EMPLACEMENTS DE CLASSE I, DIVISION 2 et CLASSE I, ZONE 2.*

Warning: *DO NOT USE THE RESET BUTTON IN A HAZARDOUS AREA.*

Avertissement: *RISQUE D'EXPLOSION—NE PAS DEBRANCHER TANT QUE LE CIRCUIT EST SOUS TENSION, A MOINS QU'IL NE S'AGISSE D'UN EMPLACEMENT NON DANGEREUX.*

Avertissement: *NE PAS UTILISER DE CONNECTEUR USB DANS LES ENVIRONNEMENTS DANGEREUX.*

Avertissement: *NE PAS UTILISER LE BOUTON DE RESET DANS UN ENVIRONNEMENT DANGEREUX.*

This device is suitable for use in Class 1 Div 2 Groups A, B, C, and D T6 locations. Ambient temperatures of -30C to +60C. UL Listed for use in ambient temperatures not exceeding 60C.

Warning: *Explosion Hazard. Do not connect or disconnect while circuit is live or unless the area is known to be free of ignitable concentrations.*

Cet appareil est certifié pour l'usage dans la Classe I, des endroits Devision 2, Groupes atmosphérique A, B, C et de D, T6. La temp ambiante -30C à +60C. UL Listed pour utilisation dans des températures ambiantes ne dépassant pas 60C.

Avertissement : *Risque D'Explosion. Ne pas débrancher tant que le circuit est électrifié sauf si il n'y a aucune concentration de vapeurs combustible.*

The device is required to be installed in a tool-secured enclosure with the appropriate type rating.

Sierra Wireless

Semtech Corporation purchased Sierra Wireless in January 2023. The Sierra Wireless brand is gradually being phased out. During the phase-out period, references to both "Semtech" and "Sierra Wireless" may appear in product documentation.

Contact Information

Sales information and technical support, including warranty and returns	Web: sierrawireless.com/company/contact-us/ Global toll-free number: 1-877-687-7795 6:00 am to 5:00 pm PST
Corporate and product information	Web: sierrawireless.com

Copyright

© 2026 Semtech. All rights reserved.

Contents

- Important Notice 2
- Wireless Communications..... 2
- Warranty..... 2
- Safety..... 2
- Sierra Wireless 3
- Contact Information 4

- Introduction to the AirLink RX55 8**
 - Key Features 8
 - Description..... 9
 - Router Configuration and Management 10
 - Power Modes 10
 - Power Draw10
 - Power Saving Features 11
 - Sample Power Consumption Scenarios..... 12
 - Dual SIM 13
 - Network Operator Switching 13
 - Accessories 13
 - Warranty..... 13

- Installation and Startup 14**
 - Tools and Materials Required..... 14
 - Installation Overview 14
 - Step 1 — Insert the SIM Cards 15
 - Step 2 — Mounting and Grounding the RX55 Router 16
 - Mounting Brackets16
 - Flat Surface Mount16
 - DIN Rail Mount17
 - Grounding the RX55 Router Chassis18
 - Step 3 — Connect the Antennas 18
 - Recommended Antenna Separation19

Step 4 — Connect the Data Cables	20
USB Port	21
Ethernet Port	21
Serial Port	21
Step 5 — Connect the Power	23
Cable Strain Relief	23
Fusing	23
DC Voltage Transients	23
Power Connector on the RX55 Router	24
Wiring Diagrams	26
I/O Configuration	28
Step 6 — Check the Router Operation	34
LED Behavior	35
Ethernet LEDs	38
Step 7 — Startup and Software Configuration	39
Configure locally with AirLink OS	39
Configure and Monitor Remotely with AirLink Management Service	40
Reboot the RX55 Router	40
Reset the RX55 Router to Factory Default Settings	40
Specifications at a Glance	41
Certification and Interoperability	41
Environmental Testing	41
Reliability Specifications	42
Included Radio Module Firmware	43
Host Interfaces	43
SIM Card Interface	44
Operating Voltage	45
Power Specifications	45
GNSS Specifications	45
GNSS Bands Supported	46
Protocols	46

Wi-Fi Performance	47
Wi-Fi Channels Supported.....	47
Wi-Fi Antenna Gain	48
Wi-Fi Output Power	48
Radio Frequency Bands	49
Carrier Aggregation Combinations	51
Mechanical Specifications	54
Screw Torque Settings	55
Regulatory Information	56
Important Information for North American Users	56
RF Exposure	56
EU	57
IECEX Compliance.....	58
Applicable Standards	58
WEEE Notice	59
Accessories.....	60
DC Power Cable (Black Connector)	60
AC Power Adapter (Black Connector).....	61
AC Power Adapter Input	61
AC Power Adapter Output	61
AC Power Adapter Environmental Specifications	62
AC Power Adapter Reliability and Quality Control	62
AC Power Adapter Safety Standards	62
AC Power Adapter EMC Standards	63
AC Power Adapter Hazardous Substances	63
AC Power Adapter Energy Efficiency	63
Dual Serial Port Adapter Cable.....	64
Serial CAN Y-Cable.....	65
Index.....	66

1: Introduction to the AirLink RX55

The Semtech® AirLink® RX55 LTE-A router is a compact, intelligent and fully-featured communications platform that provides real-time wireless capabilities for fixed and mobile applications. It is intended for use in industrial settings such as:

- Remotely monitoring and controlling infrastructure and surveillance equipment on pipelines, meters, pumps and valves in any energy, utility, or industrial application
- Tracking the location of heavy equipment and assets in the field
- Providing reliable Internet access to a mobile workforce

The RX55 router has multiple communication ports including serial, dual serial (option), CAN (Wi-Fi models only), Ethernet, and USB ports. The power connector has one GPIO pin for remote monitoring and control and one ignition sense pin to turn the router on and off.

The RX55 is an LTE cellular router that supports LTE and HSPA+ radio bands.

The RX55 router, with its rich feature set, configurable with the included AirLink OS software, is the perfect choice for a broad set of IoT solutions.

Key Features

- High-performance LTE-Advanced
- 4G performance at 2G power consumption (less than 1 W in idle mode)
- FirstNet support (Band 14) with Carrier Aggregation
- CBRS support (Band 48)
- Dual Wi-Fi 802.11ac 2.4/5 GHz
- Dual RS-232 serial port (DB9)—Base Model (with [Dual Serial Port Adapter Cable](#))
- Single RS-232 serial port (DB9)—Wi-Fi & Wi-Fi Plus Model
- CAN support for telemetry—Wi-Fi models only (with [Serial CAN Y-Cable](#))
- Fully automatic network operator switching; just insert the SIM card
- Provides network connectivity via Ethernet, Serial, and USB
- Gigabit Ethernet support (10/100/1000)
- Remote configuration, software update, and monitoring with AirLink Management Service (ALMS)
- Meets industrial-grade certifications including Class 1 Div 2, IECEx/ATEX, MIL-STD-810G, IP64 ingress protection
- Supports up to 5 VPN tunnels to support secure communications over cellular networks
- Built-in, class-leading voltage transient protection provides superior reliability and continuous operation
- E-Mark and SAEJ1455 for shock and vibration
- Active GNSS for tracking equipment
- Preprogrammed low voltage disconnect to prevent battery drain
- Security via Remote Authentication (RADIUS, TACACS+, LDAP) to centrally manage router access
- [Power Saving Features](#), including:
 - Processor Power Saving Mode
 - LED power saving mode
 - Standby mode
 - Power saving strategies such as turning off unused interfaces (USB, Serial, Ethernet), turning off GNSS, and adjusting the Ethernet data rate
- Multi-function digital input, analog input, switchable low side current sink, and high side configurable pull-up

Description

Back Panel

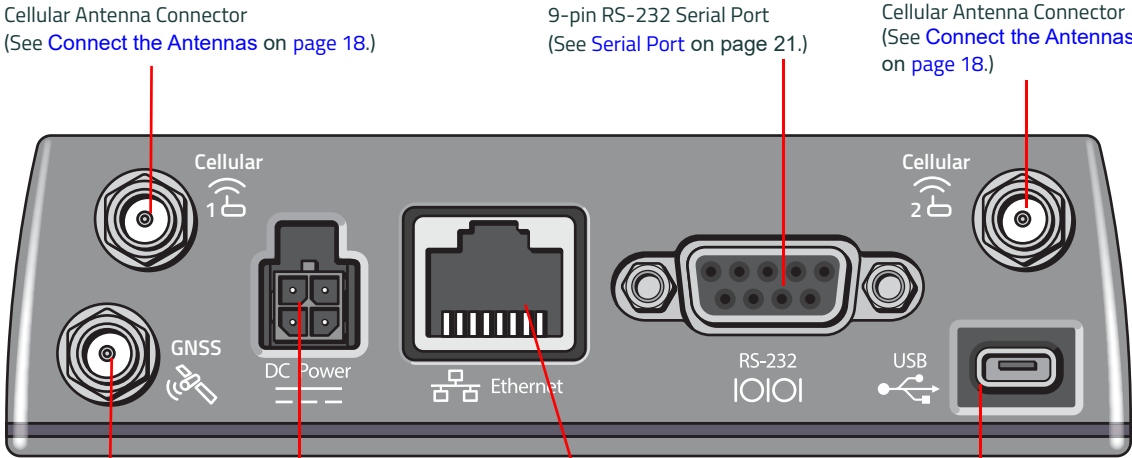

Cellular Antenna Connector
(See [Connect the Antennas](#) on [page 18](#).)

9-pin RS-232 Serial Port
(See [Serial Port](#) on [page 21](#).)

Cellular Antenna Connector
(See [Connect the Antennas](#) on [page 18](#).)

GNSS Antenna Connector
(See [Connect the Antennas](#) on [page 18](#).)

Power Connector
(See [Connect the Power](#) on [page 23](#).)

RJ-45 Ethernet Port
(See [Ethernet Port](#) on [page 21](#).)

USB 2.0 Micro-AB Port
(See [USB Port](#) on [page 21](#).)

Front Panel

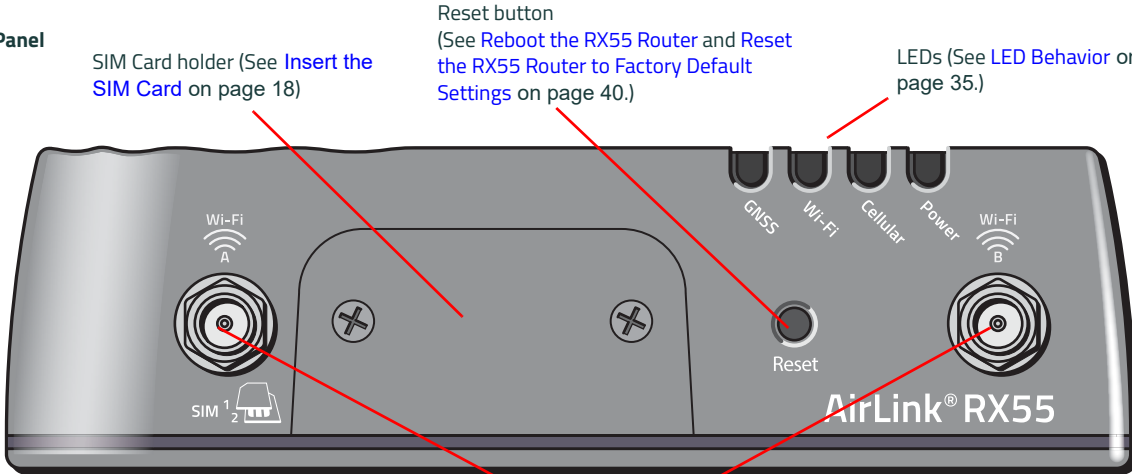

SIM Card holder (See [Insert the SIM Card](#) on [page 18](#))

Reset button
(See [Reboot the RX55 Router and Reset the RX55 Router to Factory Default Settings](#) on [page 40](#).)

LEDs (See [LED Behavior](#) on [page 35](#).)

Wi-Fi antenna connectors (Wi-Fi models only)

Figure 1-1: RX55 Router Connectors, LEDs and SIM Card Holder

Router Configuration and Management

You can configure and manage your RX55 router using:

- **AirLink OS** — a browser-based router management application
Refer to the [AirLink OS documentation](#).
- **AirLink Management Service (ALMS)**—a cloud-based router management service provided by Semtech
For more information, visit www.sierrawireless.com/ALMS or contact your Semtech distributor.

Power Modes

The AirLink RX55 router has two power modes:

- **Idle Connected**— The CPU and the radio are on.
- **Standby**— The CPU and the radio are off, but can be woken by an I/O input or at a configured time.

Power Draw

The figures in [Table 1-1](#) show the power draw for each power mode at 12 VDC.

Table 1-1: RX55 power draw

Idle Connected ^a	Standby
LTE-A: 717 mW (60 mA)	38 mW (3 mA) ^b

- Router is idle (no traffic is being sent or received)
- Standby power is dependent on temperature and input voltage. At 12V, the power draw is 38mW +/-10%

Power Saving Features

Table 1-2 provides a quick reference to the ways you can save power with the RX55.

Table 1-2: Power Saving Features

Feature	Where to configure in AirLink OS	Notes
LED Power Saving	System > LEDs > LED Powersaver Mode	Enabling LED power saving mode turns off the router LEDs to reduce the router's power consumption. For more LED information, see LED Behavior on page 35.
Disable USB Port	Hardware Interfaces > USB Interfaces > Configuration	Caution: Do not disable this port if you need to access the AirLink OS UI through a local USB connection.
Disable Ethernet Port	Hardware Interfaces > Ethernet Interfaces > Configuration	Caution: Do not disable this port if you need to access the AirLink OS UI through a local Ethernet connection.
Set Ethernet Data Rate	Hardware Interfaces > Ethernet Interfaces > Configuration	Ethernet data rates can be set to Auto, 1000base-T/Full, 100base-T/Full, 100base-T/Half, 10base-T/Full, 10base-T/Half. If your use case does not require a Gigabit Ethernet connection, choosing a slower rate results in substantial power savings. When set to 10 or 100 Mbits, both sides of the link must be set to the same fixed speed and duplex settings. If you are unable to ensure that both sides of the link have exactly the same fixed settings, it is best to use Auto.
Disable Serial Port	Hardware Interfaces > Serial Interfaces > Configuration	
Disable GNSS	Services > Location > General	GNSS is enabled by default.
Disable GNSS Antenna Bias	Services > Location > General	GNSS Antenna Bias is enabled by default. Disable when using a passive GNSS antenna, or when GNSS is disabled.
Ignition Shutdown Delay	System > Power Management > Standby Mode	If the RX55 router is installed in a vehicle, connect the ignition sense pin (Pin 3) on the DC power cable to the vehicle ignition and configure the RX55 router to shut down after a configured delay once the ignition is turned off.
Low Voltage Disconnect	System > Power Management > Standby Mode	The RX55 router enters standby mode when the voltage reaches a user-defined threshold to prevent excessive battery drain in battery-operated systems.
Standby (Time-based)	System > Power Management > Standby Mode	The RX55 router is in standby mode and automatically wakes up periodically, for example hourly or daily.
Standby (I/O-based)	System > Power Management > Standby Mode	The RX55 router is in standby mode and automatically wakes up on configured I/O input.

Sample Power Consumption Scenarios

Power consumption was measured at 12 V.

Table 1-3: Power Consumption Scenarios

Scenario	Radio	Notes	LTE Power
Standby Mode	—	—	38 mW (3 mA) ^a
LTE Idle			717 mW (75 mA)
Low Power — Serial	Idle Attached	Serial enabled	834 mW (68.8 mA)
Low Power — Ethernet	Idle Attached	10Base-T Full duplex	874 mW (72.2 mA)
Low Power — Wi-Fi ^b	Idle Attached	—	1.295 W (107 mA)
Typical without Power Saving Features ^c	Attached and connected (+20 dBm LTE)	100Base-T Full duplex, serial and USB enabled (idle), GNSS enabled (active antenna)	3700 mW (308.3 mA)
Maximum without Power Saving Features ^d	Attached and connected (+23 dBm LTE-A)	1000Base-T Full duplex (maximum throughput), serial and USB enabled, GNSS enabled (active antenna)	5500 mW (458.3 mA)
Inrush Current	1.5 A @ 12 V (Averaged over 100 μs)		

- Standby power is dependent on temperature and input voltage. At 12V, the power draw is 38mW +/- 10%
- Wi-Fi A and B set up as access points with nothing connected to them.
- Power saving features include processor power saving mode and LED power saving mode.
- Based on maximum measured performance in a lab environment. It may be possible to exceed 5500 mW by as much as 10% under some conditions.

Dual SIM

The AirLink RX55 router has two SIM card 2FF slots. You can configure which slot is the Primary SIM card—by default, the upper SIM slot is for the Primary SIM card. To configure the Primary and Secondary SIM card slots, see [Hardware Interfaces > Cellular Interfaces > Configuration](#) in AirLink OS.

When the router is powered on or reboots, it automatically connects to the network associated with the Primary SIM card. If no card is present in that slot, it connects to the network associated with the Secondary SIM card. If configured to do so, data usage is tracked independently on both SIM cards. SIM PIN configuration is also available for both SIM cards. This feature allows you to install SIM cards for two different network operators, use one SIM card initially and later change network operators by configuring the new SIM card to be the Primary SIM card.

Network Operator Switching

The AirLink RX55 comes preloaded with multiple versions of radio module firmware. When the router is powered on, it checks the stored radio module firmware versions and automatically loads the appropriate version for the installed Primary SIM card onto the radio module. While Network Operator Switching is in progress, the LEDs sequentially flash green (green LED chase).

If there is no SIM card installed in the Primary SIM card slot, the router uses the firmware associated with the SIM card in the Secondary SIM card slot.

This feature, which is intended for North American products, makes it possible to use a single RX55 hardware variant on multiple operator networks.

Accessories

The following items come with the RX55 router:

- DC power cable
- Mounting screws
- Quick Start Guide
- AirLink Complete leaflet

The following items can be ordered separately from Semtech:

- Universal AC power adapter
 - Voltage input: 100–240 VAC
 - Current output: 1.5 A
 - Part number: 2000579
- DIN rail mounting bracket (part number 6001529, see [DIN Rail Mount](#) on page 17)
- Serial Y-cable for dual serial port mode operation
 - Part number: 6001238
- Serial CAN Y-cable for telemetry applications
 - Part number: 6001479

For antenna options, please visit [the Semtech web site](#).

Warranty

You can download the RX55 router warranty from [the Semtech Source](#). Click **sign up** to register for free.

2: Installation and Startup

This chapter shows how to connect, install and start the Semtech RX55 router. It also describes the front panel LEDs, and I/O functionality.

Note: Field wiring and connections in hazardous locations must be connected as per the wiring methods requirement for Class 2 circuits mentioned in the National Electric Code and the Canadian Electric Code.

Note: The RX55 router installation must be done by a qualified technician.

Tools and Materials Required

- Power supply — AC or DC (DC power cable is supplied by Semtech)
- A SIM card (provided by your mobile network operator)
- #1 Phillips screwdriver
- Laptop computer with Ethernet cable
- LTE MIMO antennas — Main and Diversity
- Optional — GPS antenna
- Optional — a 9-pin connection cable for the RS-232 port
- Optional — DIN Rail Mounting Bracket kit (available from Semtech)

Caution: *The router has a hardened case for use in industrial and extreme environments. If you are installing it in these types of environments, use cables designed and specified for use in these types of environments to avoid cable failure.*

Installation Overview

The steps for a typical installation are:

1. Insert the SIM card(s) — [page 15](#).
2. Mount and ground the RX55 router — [page 16](#).

Note: Depending on where you are installing the RX55 router, you may want to mount the router after connecting the antenna, cables and power, and confirming correct operation.

3. Connect the antennas — [page 18](#).
4. Connect the data cables — [page 20](#).
5. Connect the power — [page 23](#).
6. Check the router operation — [page 34](#).
7. Configure the router — [page 39](#).

The following sections describe these steps in detail.

Step 1 — Insert the SIM Cards

The AirLink RX55 router has two mini-SIM (2FF) card slots. The upper slot is Slot 1 and the lower slot is Slot 2. AirLink OS references these slot numbers, and by default, the SIM card in Slot 1 is the Primary SIM card. If you are using only one SIM card, Semtech recommends that you install it in Slot 1.

If the SIM card (or SIM cards) have not already been installed, insert the SIM cards into the router before connecting any external equipment or power to the router.

To install the SIM cards:

1. Use a #1 Phillips screwdriver to remove the SIM card cover.
2. Orient the SIM card(s), as shown in [Figure 2-1](#). The gold contacts on the upper SIM card face down, and the gold contacts on the lower SIM card face up. If you are using only one SIM card, insert it in the upper SIM slot (Slot 1).
3. Gently slide the SIM cards into the slots until they click into place.

To remove a SIM card, press the SIM card in, and release it. Gently grip the SIM card and pull it out.

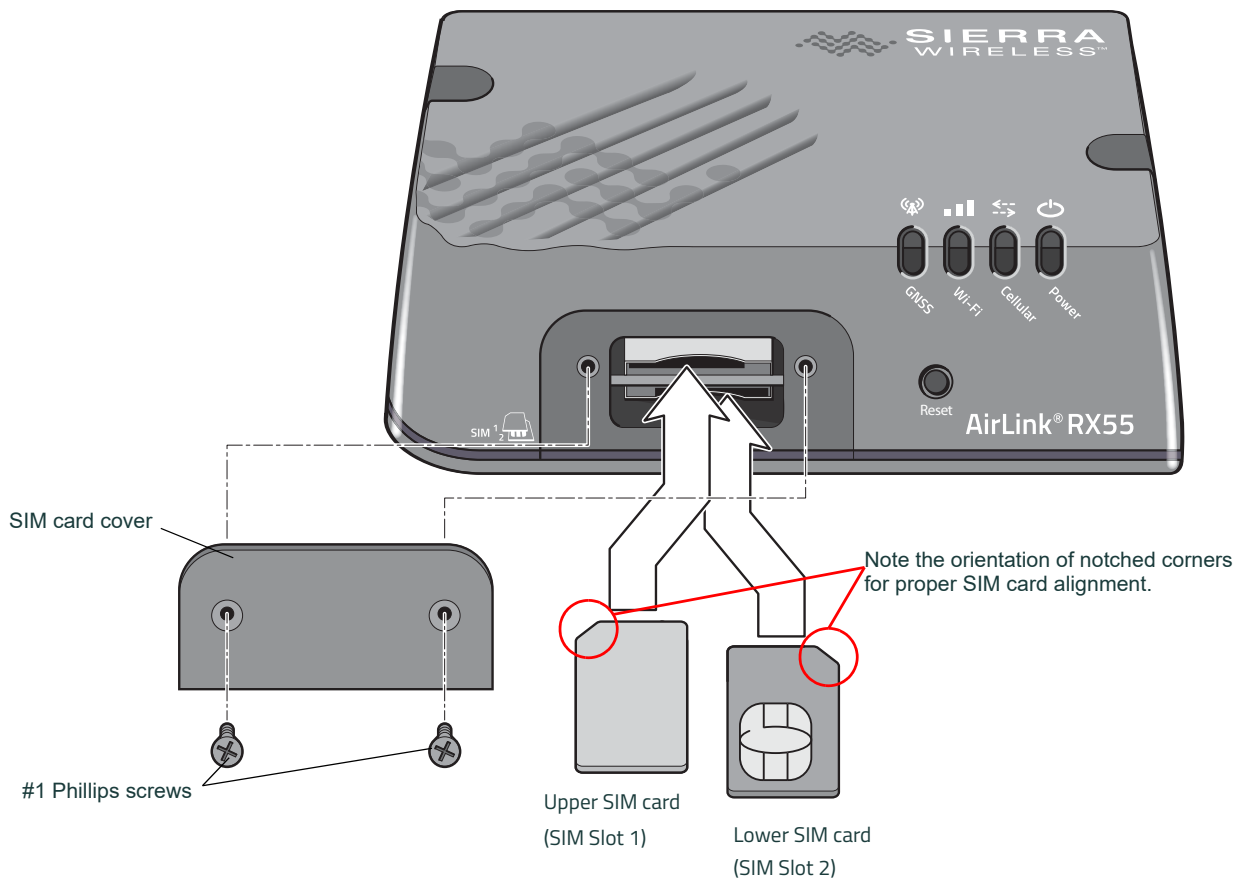

Figure 2-1: Installing the SIM Card

4. Replace the SIM card cover.

Step 2 — Mounting and Grounding the RX55 Router

Warning: This router is not intended for use close to the human body. Antennas should be at least 8 inches (20 cm) away from the operator.

Mount the router where:

- There is easy access to the cables
- Cables are not bent, constricted, close to high amperages or exposed to extreme temperatures
- The front panel LEDs are easily visible
- There is adequate airflow
- It is away from direct exposure to the elements, such as sun, rain, dust, etc.
- It will not be hit or come into contact with people, cargo, tools, equipment, etc.

Mounting Brackets

The RX55 router comes with mounting screws. An optional DIN rail mounting bracket (P/N 6001529) is available from Semtech.

Flat Surface Mount

If you are mounting the RX55 router on a flat surface, use the mounting screws that come with the router.

Note: When mounting the router in a location that could be exposed to rain (such as in a vehicle door panel, which would expose the router when the door is opened), mount the router vertically with the power connector and ports facing down, as shown in Figure 2-2. The router meets its IP64 rating when mounted in this orientation.

Note: RX55 Wi-Fi model shown.
Mounting hole measurements are the same for all RX55 models.

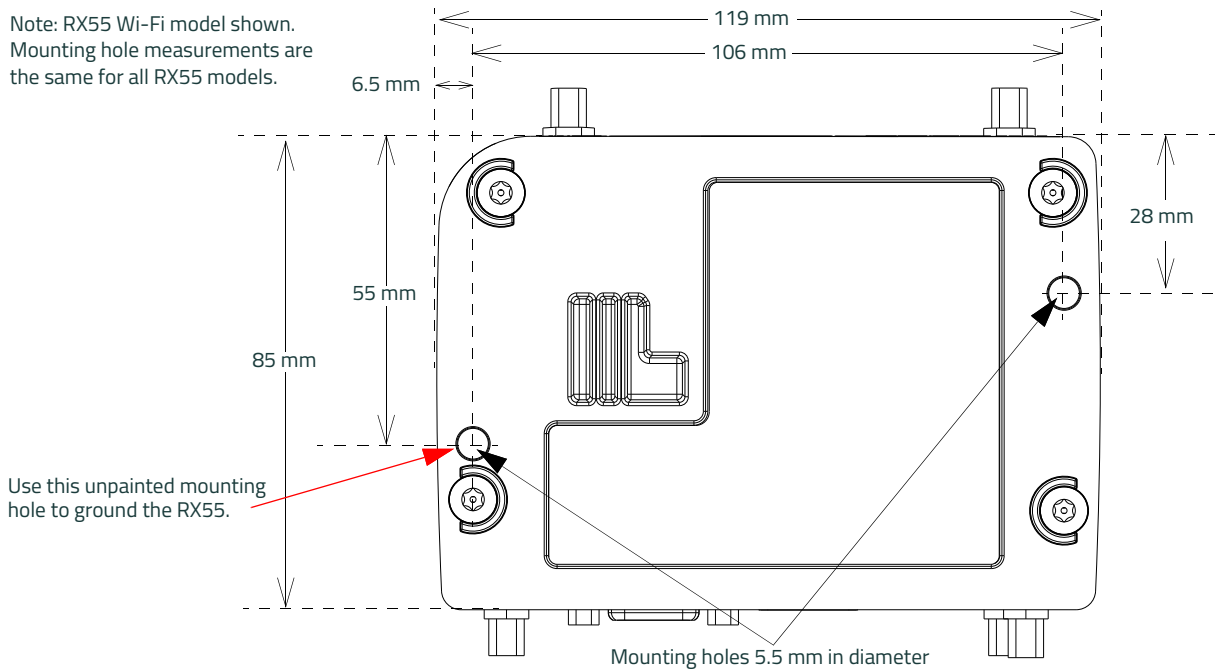

Figure 2-2: RX55 Router Mounting Hole Locations and Dimensions

DIN Rail Mount

If you are mounting the RX55 router on a DIN rail, order DIN rail mounting bracket kit (P/N 6001529) from Semtech. The kit contains:

- L-shaped DIN Rail Mounting Bracket—Qty 1
- DIN Rail Clip (35 mm EN 50022)—Qty 1
- Screws

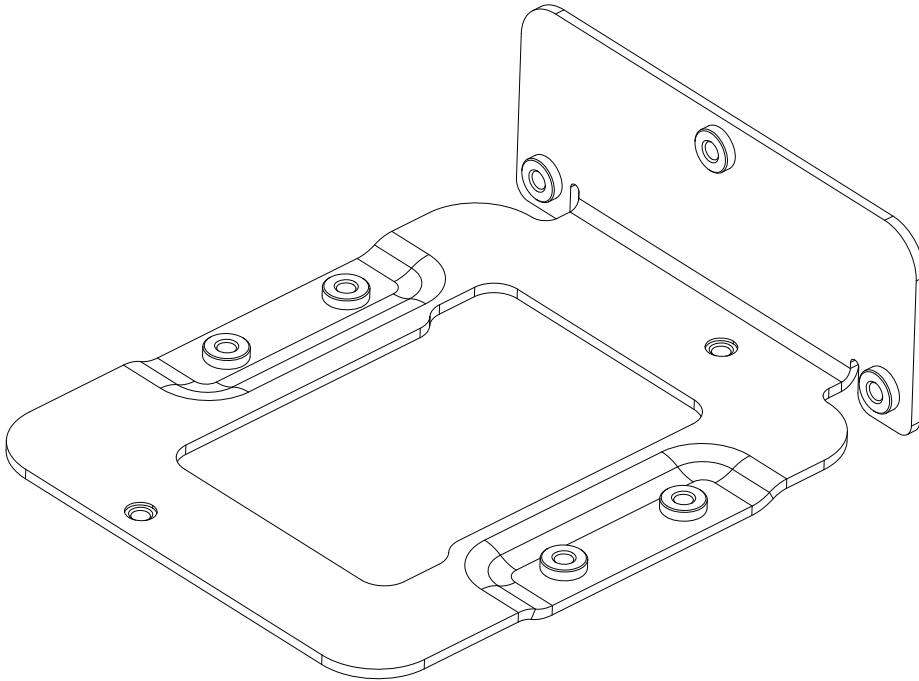

Figure 2-3: DIN Rail Mounting Bracket

To attach the RX55 router to a horizontally mounted DIN rail, in a variety of orientations:

1. Install the SIM card. (See [Step 1 — Insert the SIM Cards](#) on page 15.)
2. Test the network connectivity.
Connect the RX55 router. Power it up and ensure that you have network connectivity. (See [Step 5 — Connect the Power](#) on page 23.)
3. Place the router on the DIN rail mounting bracket, lining up the mounting holes on the underside of the router with the holes on the DIN rail mounting bracket.
4. Use the screws provided to attach the router to the bracket. Torque the screws to a maximum of 1.1 N-m (10 in-lb.).
5. Use the screws provided to attach the DIN rail clip to the bracket.
6. Attach the DIN rail clip to a horizontal DIN rail, with the spring clip at the bottom, taking into account the location information described in [Power Consumption Scenarios](#) on page 12.

Note: The DIN rail mounting bracket and clip in the Semtech kit should only be used on horizontally-mounted DIN rail.

Grounding the RX55 Router Chassis

For DC installations (with a fixed “system” ground reference), you must ground the RX55 chassis to this system ground reference.

To ensure a good grounding reference, either:

- Attach the RX55 to a grounded metallic surface.
- Connect one end of a short 18 AWG or larger gauge wire to the unpainted upper left mounting hole (see [Figure 2-2](#)) and connect the other end to the system ground reference or (if mounted in a vehicle) the vehicle chassis.

Note: In some routers the upper left mounting hole is painted. If you use the mounting screw and washer included with your router, this mounting hole still provides an effective ground, as the washer removes enough paint to allow contact between the wire and the metal chassis.

Step 3 — Connect the Antennas

Warning: *This router is not intended for use close to the human body. Antennas should be at least 8 inches (20 cm) away from the operator.*

The RX55 router has up to three female SMA antenna connectors. The number of connectors depends on product variant:

- Cellular × 2 antenna connector
- GNSS antenna connector

In addition, the RX55 with Wi-Fi has two male SMA antenna connectors (see [Figure 2-4](#) on page 19).

Important: *Approved LTE antennas are mandatory (not optional) for correct operation of LTE cellular radios. For more information, see our [AirLink Antennas page](#).*

No support for connection reliability, throughput or performance inquiries will be offered for systems that do not have the appropriate antenna configurations.

Note: The antennas should not exceed the maximum gain specified in [RF Exposure](#) on page 56. In more complex installations (such as those requiring long lengths of cable and/or multiple connections), you must follow the maximum dBi gain guidelines specified by the radio communications regulations of the Federal Communications Commission (FCC), Industry Canada, or your country's regulatory body.

Note: Take extra care when attaching the antennas to the SMA connectors. Finger tight (approximately 0.6 – 0.8 Nm/5 – 7 in-lb.) is sufficient and the max torque should not go beyond 1.1 Nm (10 in-lb.).

To install the antennas:

1. Connect the cellular antenna to the SMA cellular antenna connector.
Mount the cellular antenna so there is at least 20 cm between the antenna and the user or bystander.
2. Connect a second antenna to the SMA Cellular 2 antenna connector.
3. If used, connect a GNSS antenna to the SMA GNSS antenna connector.
Mount the GNSS antenna where it has a good view of the sky (at least 90°).

Note: AirLink OS is configured by default for an active GNSS antenna. If you are using a passive antenna, after the router is installed, log in to AirLink OS, go to Services > Location > General and set the GNSS Antenna Bias to Off.

4. For Wi-Fi-capable routers, connect the Wi-Fi antennas to the SMA Wi-Fi connectors.

Note: If any antenna is located away from the router, keep the cables as short as possible to prevent the loss of antenna gain. Route the cables so that they are protected from damage and will not be snagged or pulled on. There should be no binding or sharp corners in the cable routing. Excess cabling should be bundled and tied off. Make sure the cables are secured so their weight will not loosen the connector from the router over time.

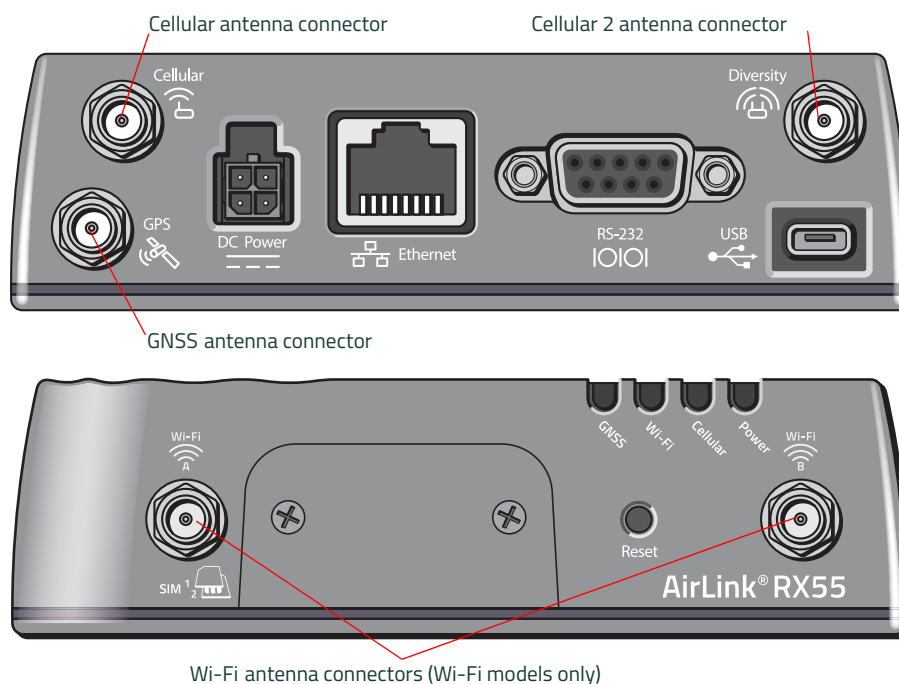

Figure 2-4: Antenna Connectors

Recommended Antenna Separation

The recommended antenna separation is related to the band frequency/wavelength. To accommodate the shortest frequency/longest wavelength band supported by the RX55, Semtech recommends a minimum antenna separation of 214 mm for best results, and if necessary, a separation of 107 mm for acceptable results.

Table 2-1: Recommended Antenna Separation

Service	Frequency (MHz)	Wavelength (λ) (mm)	Best Antenna Separation (mm) ($1/2 \lambda$)	Good Antenna Separation (mm) ($1/4 \lambda$)
LTE	700	428	214	107
LTE	800	375	187	94
LTE	900	333	167	83
LTE	1800	167	83	42
LTE	2100	143	71	36
LTE	2600	115	58	29
WCDMA	850	353	176	88
WCDMA	900	333	167	83
WCDMA	1900	158	79	39
WCDMA	2100	143	71	36

Step 4 — Connect the Data Cables

The RX55 router has the following ports for connecting data cables:

- [USB Port](#) (Micro-AB)
- [Ethernet Port](#) (RJ-45) — Use a Cat 5e or Cat 6 Ethernet cable
- [Serial Port](#) (9-pin RS-232)

USB Port

Warning: *Do not use the USB port in a potentially explosive environment.*

The USB port complies with USB Version 2.0 for high speed operation and can be configured to operate in one of two modes:

- **Virtual Ethernet Port:** The RX55 behaves as if the PC were connected to an Ethernet port, allowing access to the Internet and the router's internal web server. This is the default setting.
- **Virtual Serial Port:** The RX55 behaves as if it was connected to a standard serial port.

For information about setting the USB mode and configuring a USB connection, see the AirLink OS documentation.

Semtech recommends:

- Using a USB 2.0 cable
- Connecting directly to your computer for best throughput.

Ethernet Port

- IEEE 802.3 Ethernet specification for 1000 Mbps speed (Gigabit Ethernet) with fallback to 100 or 10 Mbps (Cat 5e or Cat 6 cable is required for Gigabit Ethernet)
- Auto-crossover support
- Auto-negotiation detects the speed of the connecting device for 1000base-T, 100base-T, or 10base-T

To optimize Ethernet throughput, ensure that you update:

- Windows, to 10.0.19042 or later
- Your PC's Ethernet driver

Check your Windows Device Manager for the current driver settings. (For Dell laptops with an Intel Ethernet Connection I219-LM, update to 12.19.0.18 or later.)

Serial Port

The RX55 9-pin serial port connects directly to most computers or other devices with a standard serial straight-through cable.

Note: If you have a DCE device, you need to use a null modem (cross-over) cable.

The same serial port can be configured as a dual 4-wire serial port, and connect to devices with a Y cable (Semtech part number 6001238). The Dual Port Mode setting is available in AirLink OS under Hardware Interfaces > Serial > Configuration > Dual-Mode Enable.

- Used for connecting serial devices and configuration
- Complies with the EIA RS-232D specification for DCE equipment
- Output driver levels swing from -7 VDC to +7 VDC with normal loading

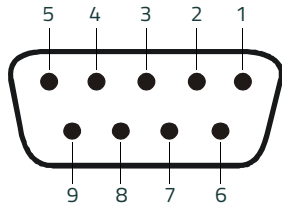

Figure 2-5: DB-9 Female Serial Connector

Table 2-2: Serial Connector Pin-out (Single Port Mode)

Name	Pin	Description	Type
DCD	1	Data Carrier Detect	OUT
RXD	2	Receive Data	OUT
TXD	3	Transmit Data	IN
DTR	4	Data Terminal Ready	IN
GND	5	Main GND. Connected internally to BOARD GND	GND
DSR	6	Data Set Ready	OUT
RTS	7	Ready To Send	IN
CTS	8	Clear To Send	OUT
RI	9	Not connected	—

Table 2-3: Serial Connector Pin-out (Dual Port Mode)

Name	Pin	Description	Type
CTS_2	1	Port 2 Clear To Send	OUT
RXD	2	Port 1 Receive Data	OUT
TXD	3	Port 1 Transmit Data	IN
TXD_2	4	Port 2 Transmit Data	IN
GND	5	Main GND. Connected internally to BOARD GND	GND
RXD_2	6	Port 2 Receive Data	OUT
RTS	7	Port 1 Ready To Send	IN
CTS	8	Port 1 Clear To Send	OUT
RTS_2	9	Port 2 Ready To Send	IN

Step 5 — Connect the Power

The AirLink RX55 router comes with a 3 meter (10 ft.) DC power cable. You can also purchase an optional AC adapter.

Note: Electrical installations are potentially dangerous and should be performed by personnel thoroughly trained in safe electrical wiring procedures.

The RX55 router supports a voltage range between 7 V and 36 V, but since low voltage standby mode is enabled by default (standby voltage is 9 V; resume voltage is 10.5 V), you must supply at least 10.5 V at startup.

If you want to operate the router at a lower voltage, change the low voltage settings once the router is up and running. For more information, refer to the AirLink OS documentation.

Cable Strain Relief

Semtech recommends using cable strain relief for installations in high-vibration environments.

Place the cable strain relief within 200 mm (8 in.) of the RX55 router to reduce the mass of cable supported by the power connector under vibration. Ideally, the strain relief mounting for the DC cable should be attached to the same object as the router, so both the router and cable vibrate together. The strain relief should be mounted such that it does not apply additional stress on the power connector, i.e. the cable should not be taut and should not pull the power connector at an angle.

Fusing

For DC installations, Semtech recommends fusing the power input using a 4.0 A fast-acting fuse.

DC Voltage Transients

The AirLink RX55 router has built-in protection against vehicle transients including engine cranking (down to 5.0 V) and load dump, so there is no need for external power conditioning circuits. For details, see [Industry Certification for Vehicles](#) on page 41.

Power Connector on the RX55 Router

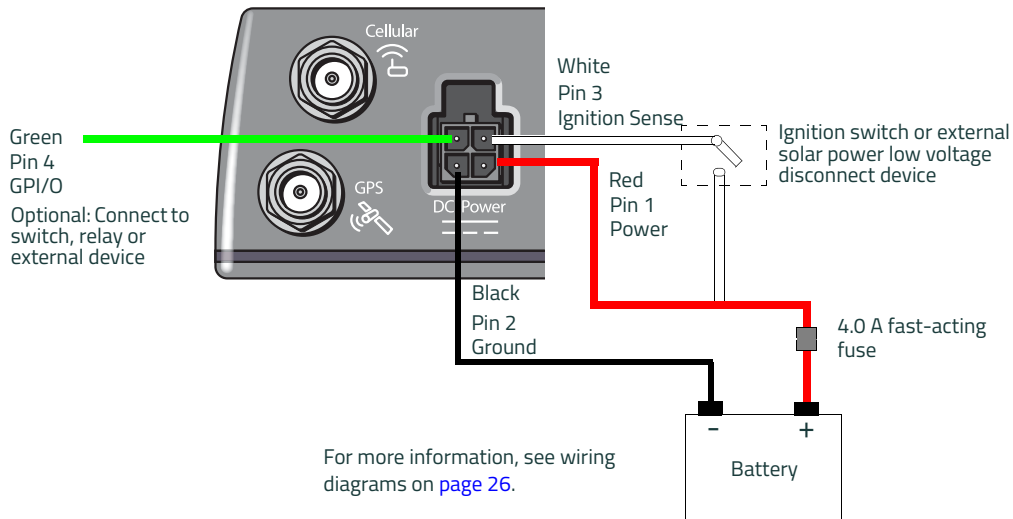

Figure 2-6: DC Power Cable Connections (Colors indicate DC cable wire colors.)

Table 2-4: Power Connector Pin and DC Cable Wires

Pin	Name	DC Cable Wire Color	Description	Type
1	Power	Red	Main power supply for device <i>Note: When the router switches to Low Power mode based on a Low Voltage trigger, the voltage is monitored on the Red (Power) wire.</i>	PWR
2	Ground	Black	Main device ground	PWR

Table 2-4: Power Connector Pin and DC Cable Wires

Pin	Name	DC Cable Wire Color	Description	Type
3	Ignition Sense	White	<p>Semtech recommends using the Ignition Sense wire to turn the router off. It should not be turned off by disconnecting the power.</p> <hr/> <p><i>Note: If you do not connect pin 3 to the ignition, you MUST connect it to the positive terminal of your power supply or battery. If you are using a Semtech AC adapter, the connection is inside the cable.</i></p> <hr/> <p>For installations where the router is turned on/off, use the white wire in the DC cable connected to Pin 3 to:</p> <ul style="list-style-type: none"> Turn the router on/off with the vehicle ignition <hr/> <p><i>Note: To turn the router on/off with the vehicle ignition, Semtech strongly recommends using an unswitched VCC on Pin 1 (Red, Power wire on DC cable) with Pin 3 (White, Ignition sense wire on DC cable) connected to the ignition.</i></p> <hr/> <ul style="list-style-type: none"> Turn the router on/off with a low voltage disconnect device <hr/> <p><i>Note: For solar applications, if you want the router to turn off when the voltage drops below a defined level, connect Pin 3 to an external low voltage disconnect.</i></p> <hr/>	I
4	GPIO	Green	<p>User configurable digital input/output or analog voltage sensing input. Connect to switch, relay or external device. For more information, see I/O Configuration on page 28.</p>	I/O

Wiring Diagrams

Recommended Vehicle Installation

For vehicle installations, Semtech recommends connecting the white Ignition Sense wire to the vehicle's ignition switch, as shown in the following illustration.

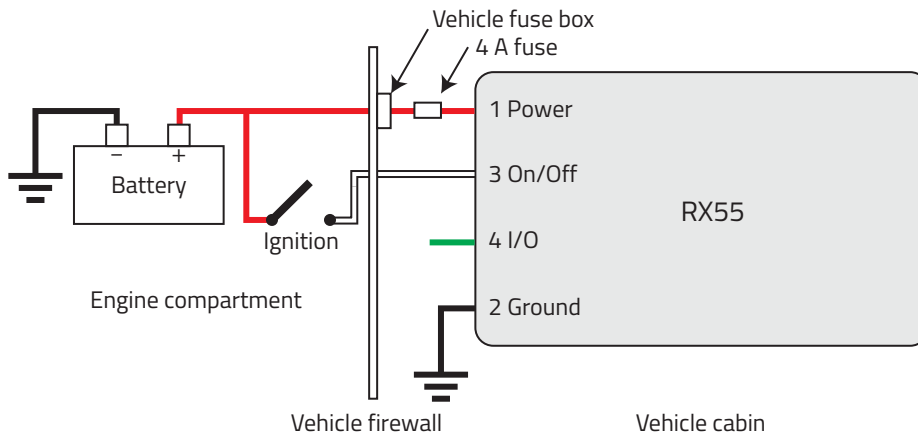

Figure 2-7: Recommended Vehicle Installation

The recommended vehicle installation allows the router to operate with the vehicle. When the vehicle ignition is off, the router is off. If desired, you can configure a delay between the time the vehicle's ignition shuts off, and the time the router shuts down. A delayed shutdown is especially useful if you want to maintain a network connection while the vehicle's engine is shut off for short periods, such as in a delivery vehicle.

- Pin 1 (Power) — Use the red wire in the DC cable to connect Pin 1 to the power source. Include a 4.0 A fast-acting fuse in the input power line. Semtech recommends using a continuous (unswitched) DC power source.
- Pin 2 (Ground) — Use the black wire in the DC cable to connect Pin 2 to ground. See also [Grounding the RX55 Router Chassis](#) on page 18.
- Pin 3 (Ignition Sense) — Semtech recommends always using the Ignition Sense wire (Pin 3) to turn the router off. It should not be turned off by disconnecting the power.

Alternate Vehicle Installation

The main difference between this installation and the standard vehicle installation is that you can configure a timer to turn the router on at set intervals for a configured length of time; for example 20 minutes once every 24 hours when the ignition is off. Also, instead of the router turning on and off, the router alternates between on and standby mode.

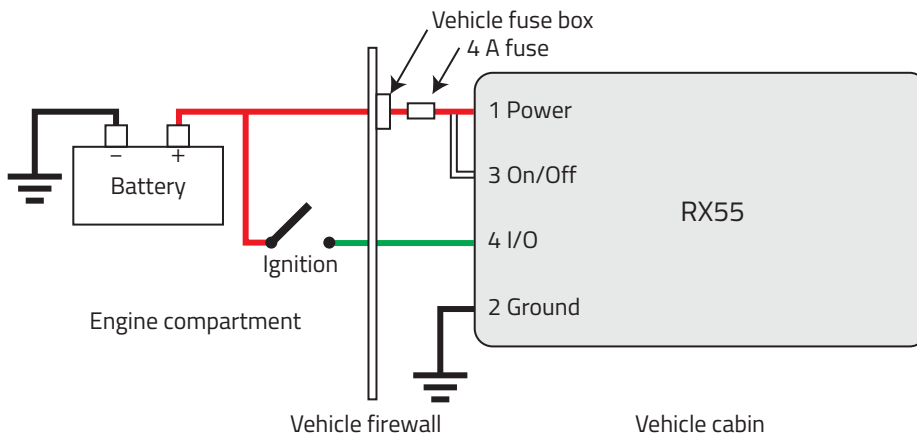

Figure 2-8: Alternate Vehicle Installation

- Pin 1 (Power) — Use the red wire in the DC cable to connect Pin 1 to the power source. Include a 4.0 A fast-acting fuse in the input power line. Semtech recommends using a continuous (unswitched) DC power source.
- Pin 2 (Ground) — Use the black wire in the DC cable to connect Pin 2 to ground. See also [Grounding the RX55 Router Chassis](#) on page 18.
- Pin 3 (Ignition Sense) — Connected to power
- Pin 4 (I/O) — Connected to ignition

Fixed Installation

For fixed installations, connect the wires as shown in the figure below. You can configure Low voltage disconnect to force the router into Standby mode when the voltage is low.

Note: When the router switches to Low Power mode based on a Low Voltage trigger, the voltage is monitored on the Red, Power wire.

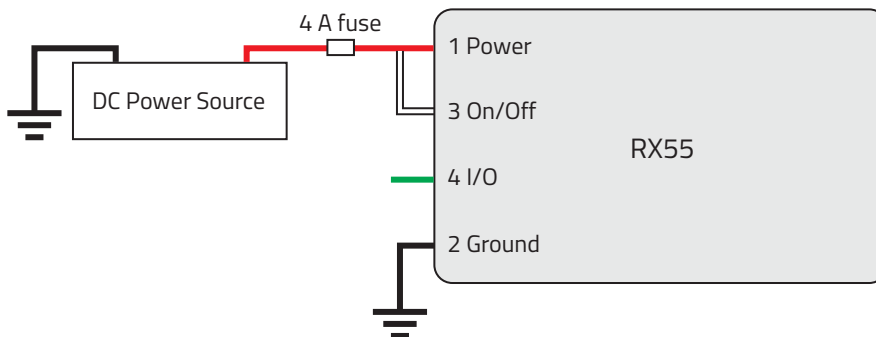

Figure 2-9: Fixed Installation without I/O

- Pin 1 (Power) — Use the red wire in the DC cable to connect Pin 1 to the power source. Include a 4.0 A fast-acting fuse in the input power line. Semtech recommends using a continuous (unswitched) DC power source.
- Pin 2 (Ground) — Use the black wire in the DC cable to connect Pin 2 to ground. See also [Grounding the RX55 Router Chassis](#) on page 18.
- Pin 3 (Ignition Sense) — Connected to power

Fixed Installation with I/O Input Triggered by Standby Mode

If you have a fixed installation where you want to use the I/O to monitor an external device such as a motion detector, remote solar panel, or a remote camera, refer to [Figure 2-10](#). You can configure the I/O line to wake the router up for a configured length of time, and use Low voltage disconnect to put the router in Standby mode if the voltage falls below a configured value.

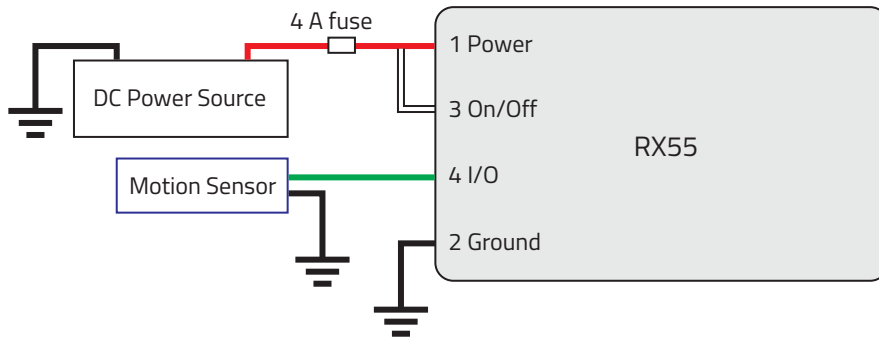

Figure 2-10: Fixed Installation with I/O

- Pin 1 (Power) — Use the red wire in the DC cable to connect Pin 1 to the power source. Include a 4.0 A fast-acting fuse in the input power line. Semtech recommends using a continuous (unswitched) DC power source.
- Pin 2 (Ground) — Use the black wire in the DC cable to connect Pin 2 to ground. See also [Grounding the RX55 Router Chassis](#) on page 18.
- Pin 3 (Ignition Sense) — Connected to power
- Pin 4 (GPIO) — Use the green wire for I/O configurations. See [I/O Configuration](#).

I/O Configuration

You can use the Pin 4 (GPIO) green wire as:

- A pulse counter
(See [Table 2-5](#) on page 29 and [Figure 2-11](#) on page 29.)
- A digital input
(See [Table 2-5](#) on page 29 and [Figure 2-12](#) on page 30.)
- A high side pull-up/dry contact switch input
(See [Table 2-7](#) on page 31 and [Figure 2-13](#) on page 31.)
- An analog input
(See [Table 2-8](#) on page 32 and [Figure 2-14](#) on page 32.)
- A low side current sink
(See [Table 2-9](#) on page 33 and [Figure 2-16](#) on page 33.)
- A digital output/open drain
(See [Table 2-10](#) on page 34 and [Figure 2-17](#) on page 34.)

For more information, refer to the AirLink OS documentation (I/O documentation pending).

Note: You can configure the GPIO Pin 4 in AirLink OS or ALMS to trigger standby mode, to sink current, or to pull up the voltage. If you are using the I/O line to trigger standby mode, you cannot configure it to sink current or pull up the voltage. Likewise, if you are using the I/O line to either sink current or pull up the voltage, you cannot use it to trigger standby mode.

Note: During bootup, the I/O settings remain in their default state: the internal pull-up resistor is disabled, and output current sink switch is open. After bootup, any custom I/O settings are applied. This may take approximately 30 seconds after the router is restarted or powered on.

You can use Pin 4 in conjunction with Telemetry to configure the RX55 router to send a report when the state of the monitored router changes, for example when a switch is opened or closed. For more information, refer to the [AirLink OS documentation](#) (Configuring GNSS and Location Reports).

Pulse Counter

You can use the green wire to connect Pin 4 to a pulse counter. The digital pulse counter is not available in Standby mode.

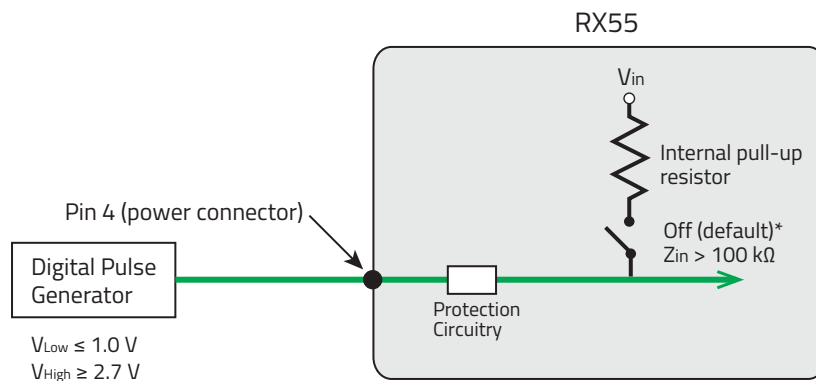

Figure 2-11: Digital Input / Pulse Counter

Note: Values may vary, depending on signal noise.

Table 2-5: Pulse Counter

Pull-up	State	Minimum	Typical	Maximum	Units
Off	Low	—	—	1.0	V
	High	2.7	—	V_{in}	V

Digital Input

You can use the green wire to connect Pin 4 to a digital input to detect the state of a switch such as a vehicle ignition, or to monitor an external device such as a motion detector, a remote solar panel, or a remote camera. Digital input can also be used with the standby timer.

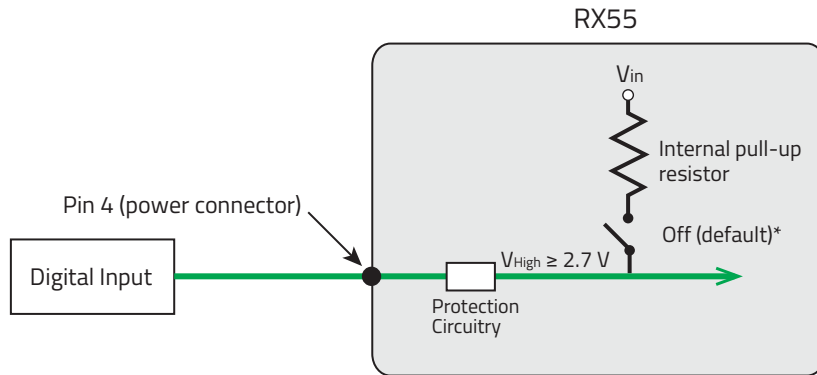

Figure 2-12: Digital Input

Table 2-6: Digital Input

Pull-up	State	Minimum	Typical	Maximum	Units
Off	Low	—	—	1.0	V
	High	2.7	—	V_{in}	V

High Side Pull-up / Dry Contact Switch Input

You can use the green wire to connect Pin 4 to a dry contact switch. The dry contact switch is not available in Standby mode.

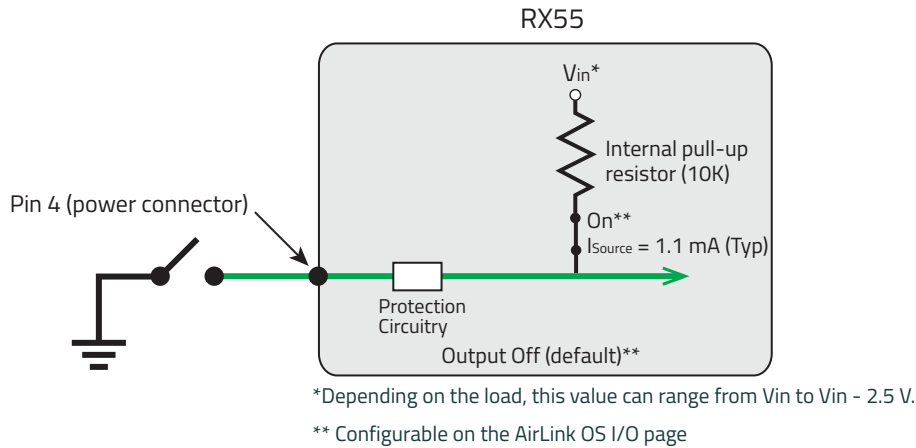

Figure 2-13: High Side Pull-up / Dry Contact Switch Input

Table 2-7: High Side Pull-up / Dry Contact Switch Input

	Minimum	Typical	Maximum	Units	Comments
Source Current	0.6 $V_{in} = 7 \text{ V}$	1.1 $V_{in} = 12 \text{ V}$	3.5 $V_{in} = 36 \text{ V}$	mA	Maximum current the voltage output can provide (depends on V_{in})
V_{out}	$V_{in} - 2.5$	—	V_{in}	V	The voltage on Pin 4 when the high side pull-up is enabled (depends on V_{in} and power consumption)

Analog Input

You can use the green wire to connect Pin 4 to an analog sensor. As an analog input (voltage sensing pin), the router monitors voltage changes in small increments. This allows you to monitor equipment that reports status as an analog voltage.

Pin 4 detects inputs of 0.5–36 V referenced to ground. When used with a sensor to transform values into voltages, the pin can monitor measurements such as temperatures, sensors, or input voltage.

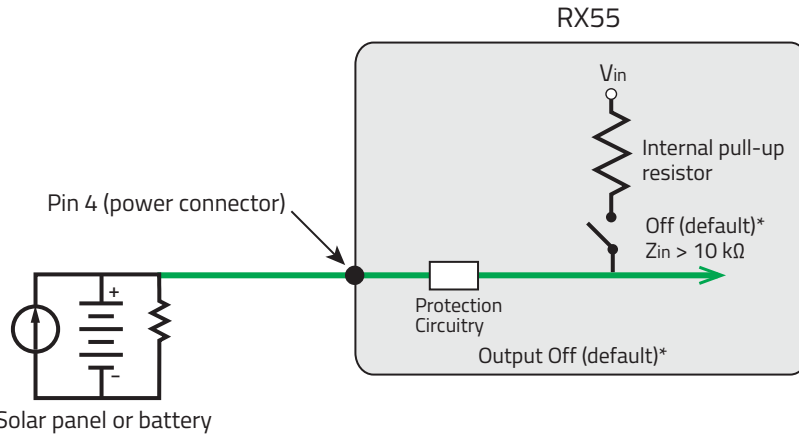

Figure 2-14: Analog Input

Table 2-8: Analog Input

Pull-up		Minimum	Typical	Maximum	Units	Comments
Off	Analog Input Range	0.5	—	36	V	—
	Analog Input Accuracy	-1.5%	0.50%	1.5%	—	—

Data sampling is handled by a dedicated microprocessor. In order to filter noisy signals, twenty measurements are taken over a 250 ms interval and they are averaged to generate a sample. If the change since the last sample is significant, a notification is sent to the CPU for updating the current value and for use in AirLink OS reports.

Changes are considered significant if the change is 150 mV or more. If there has not been a significant change to the parameter being monitored, the CPU reads a sample every 2.5 minutes, which detects small changes.

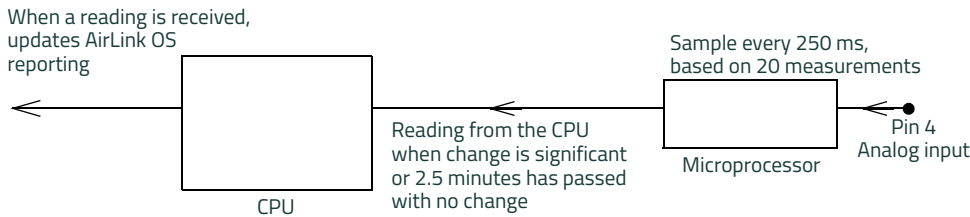
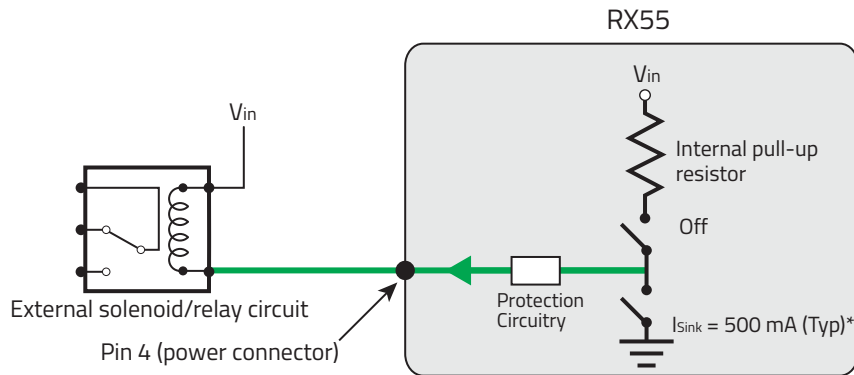

Figure 2-15: Analog Input Sampling and Reading

Note: The same method is used to sample the input voltage and the internal board temperature for AirLink OS reports. The significant changes are 300 mV for the input voltage and 1 °C for the board temperature.

Low Side Current Sink Output

You can use Pin 4 as a low side current sink, for example, to drive a relay.



* See Table 2-9 on page 33 for more details.

Figure 2-16: Low Side Current Sink

Table 2-9: Low Side Current Sink

Pull-up	State	Minimum	Typical	Maximum	Units	Comments
Off	On	250	500	1000	mA	$I_{\text{Typical}} = 25^{\circ}\text{C}$ $I_{\text{Min}} = 70^{\circ}\text{C}$ $I_{\text{Max}} = -40^{\circ}\text{C}$
Off	Off	—	0	—	mA	$V_{in} = 12$

Note: The router protection circuitry has a high-impedance ($\sim 125 \text{ k}\Omega$) path to ground. If Pin 4 is connected to 12 V, there will be a small current flow ($\sim 100 \mu\text{A}$) into Pin 4 during bootup. This flow is countered when the internal pull-up resistor ($10 \text{ k}\Omega$) becomes active after bootup. Depending on your application, you may need to install an external pull-up resistor ($10 \text{ k}\Omega$) in order to nullify the small input current flow for the first 30 seconds during bootup.

Digital Output/Open Drain

You can use Pin 4 as an open drain to drive an external digital input

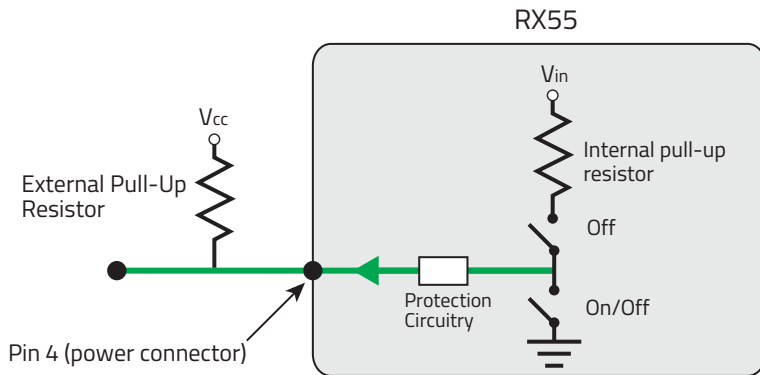

Figure 2-17: Digital Output/Open Drain

Table 2-10: Digital Output / Open Drain

Pull-up	State	Minimum	Typical	Maximum	Units	Comments
Off	Off	Open Circuit	—	—	—	—
	Active Low	—	—	0.5	V	5 mA, ≤ 5 V

Step 6 — Check the Router Operation

- When power is supplied to the AirLink RX55 router, it powers up automatically, as indicated by the flashing LEDs. If it does not turn on, ensure that the:
 - Power connector is plugged in and supplying voltage between 7 – 36 V.

Note: Although the RX55 router operates in the range 7–36 V, low voltage standby mode is enabled by default, so in order to avoid the router powering into standby mode, ensure that it is supplied with more than 10.5 V at startup. (If desired, you can change the low voltage standby settings once the router is operational.) If the Power LED is red, the router is in standby mode.

- Ignition Sense (pin 3) is connected to the battery or power source (see [Step 5 — Connect the Power](#) on page 23 for details)

LED Behavior



Figure 2-18: RX55 LEDs

LED Patterns

The RX55's LEDs display four device statuses (see [Table 2-11](#))—GNSS, Wi-Fi, Cellular radio, and Power using a variety of pattern types and colors:

- Solid—Single color, always on
- Fast flashing—One color on for 0.2 s, then off or another color for 0.2 s
- Slow flashing—One color on for 0.25 s, then off or another color for 0.75 s
- Pulse—One color on for 0.5 s, then a 0.2 s pulse off or another color
- Chase—All LEDs on in sequence for 0.2 s each, from left to right, continuously

Note: To reduce the router's power consumption, you can turn off the LEDs by going to System > LEDs > LED Powersaver Mode and clicking ENABLE.

Table 2-11: LED Behavior







 GNSS	
Solid Green	
Satellite fix available	
Solid Red	
Searching for a satellite fix	
Fast Flashing Red	
(Forthcoming) GNSS antenna is open or shorted.	
<i>Note: Antenna may appear to be connected, but current draw is too high or too low.</i>	
Slow Flashing Red	
(Forthcoming) GNSS antenna is disconnected.	
<i>Note: Current draw is below predefined threshold.</i>	
Off	
GNSS is off / disabled	

Table 2-11: LED Behavior (Continued)









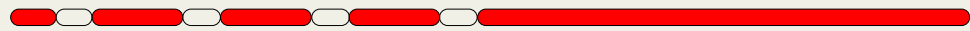

 Wi-Fi	
Solid Green (pulse off with activity)	
Connected in Client mode (good signal) with traffic or Connected in Access Point mode with traffic (Client mode not configured) <i>Note: If access point and client are configured and have traffic at same time, LED displays the client status (i.e. displaying a connected Depot is the priority).</i>	
Slow Flashing Green	
Wi-Fi client enabled but not connected, and no AP is enabled.	
Solid Yellow (pulse off with activity)	
Connected in client mode (fair signal) with traffic <i>Note: If access point and client are configured and have traffic at same time, LED displays the client status (i.e. displaying a connected Depot is the priority).</i>	
Solid Red (pulse off with activity)	
Connected in client mode (poor signal) with traffic <i>Note: If access point and client are configured and have traffic at same time, LED displays the client status (i.e. displaying a connected Depot is the priority).</i>	
Off	
No Wi-Fi enabled (no AP, no Wi-Fi client), or not available on this RX55 model.	
 Cellular	
Solid Green (pulse off with activity)	
Connected to a 4G/3G network with a good connection (equivalent to 4–5 bars). Pulsing off for activity.	
Slow Flashing Green	
Connecting to a 4G/3G network	
Yellow (pulse off with activity)	
Connected to a 4G/3G network with a fair connection (equivalent to 2–3 bars).	
Solid Red (pulse off with activity)	
Connected to a network with a poor connection (equivalent to 1 bar).	
Slow Flashing Red	
No network connection	
Slow Alternating Flashing Red/Yellow	
Network Operator Switching is enabled, but the required radio module firmware is not currently available on the router. For more information, see Radio Module Firmware Management on the Semtech Source.	

Table 2-11: LED Behavior (Continued)

Off	
Cellular radio disabled	
Power	
Solid Green	
Router operating normally with ignition on	
Fast Flashing Green	
Router is rebooting after Reset button pressed for <5 seconds (or reset from AirLink OS)	
Solid Yellow	
<ul style="list-style-type: none"> Router is booting or Router is thermally throttled—one or more of CPU, cellular radio, and Wi-Fi radio has exceeded threshold. When operating temperature returns to normal, LED returns to solid green. 	
Fast Flashing Yellow	
Router is rebooting and being reset to factory defaults, after Reset button is pressed for 20–40 seconds	
Solid Red	
Power is present, but router is not running (e.g. ignition is off, router is in standby mode, etc.)	
<i>Note: If the router is in standby mode, the Power LED will be solid red only if the AirLink OS Standby LED setting is enabled, otherwise the LED will be Off. (By default, the setting is enabled.)</i>	
Fast Flashing Red	
Router is rebooting and being reset to the default template, after Reset button pressed for 5–20 seconds.	
Slow Flashing Red	
Router is not operating because operating temperature range is exceeded (i.e. thermal shutdown).	
Fast Alternating Flashing Yellow / Red	
Reset button held > 40 seconds, canceling the reset action and rebooting normally when released. (i.e. if pressing reset >5 seconds and decide that Router should do a regular reboot (not a reset to default template or factory defaults, continue pressing Reset until LED alternates Yellow and Red flashes.)	
Off	
<ul style="list-style-type: none"> No power or Router is in standby mode and the AirLink OS Standby LED setting is disabled. 	
All LEDs	
Yellow LED chase	
Router firmware update in progress	
Important: Do not turn off the power while the update is in progress.	

Table 2-11: LED Behavior (Continued)

Green LED chase	
Radio module firmware update in progress	
<p>Important: <i>Do not turn off the power while the update is in progress.</i></p>	

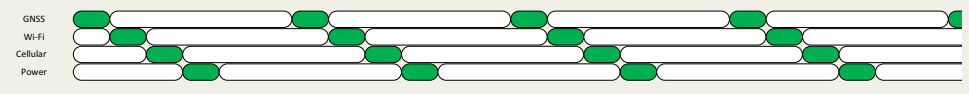
Ethernet LEDs

The Ethernet connector has two LEDs that indicate speed and activity. When looking into the connector:

- Activity— The right LED is solid amber when a link is present and flashing amber when there is activity.
- Connection Speed— The left LED indicates the Ethernet connection speed:
 - Solid Green — 1000 Mbps
 - Solid Amber — 100 Mbps
 - Off — 10 Mbps

Step 7 — Startup and Software Configuration

You can configure the AirLink OS software on the RX55 router using:

- Web-based UI
- [AirLink Management Service](#) (cloud-based application)

Configuring with AirLink OS

You can configure the RX55 using:

- AirLink OS (the RX55's web interface)
- AirLink Management Service (cloud-based application)

Configure locally with AirLink OS

To access the AirLink OS:

1. Connect to the RX55 through a LAN connection (e.g. a configured Ethernet port or Wi-Fi connection).
2. Open a browser window and enter 192.168.1.1, and bypass any certificate notifications in your browser.

Note: It takes the RX55 from 1 to 2 minutes to respond after power up.

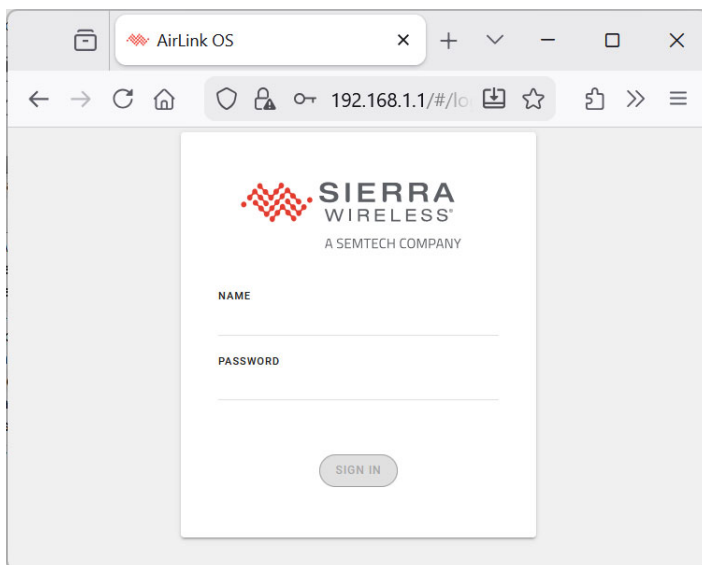

Figure 2-19: AirLink OS login window

3. Enter the default administrator User name and Password and click SIGN IN.
 - User Name: *admin*
 - Password: *(printed on the RX55 label)*

Note: For system security, ensure that you change the default password as soon as possible.

4. Configure the RX55 as required.

Configure and Monitor Remotely with AirLink Management Service

AirLink Management Service (ALMS) allows remote management of all your routers from one user interface.

Some of its features include:

- Centralized, remote monitoring for all your AirLink routers
- Continuous status monitoring of important health data such as signal strength
- Location monitoring, including world map views
- Configure individual routers or use templates to perform batch configurations of your AirLink routers
- Single-click over-the-air firmware updates to all your routers
- Compatible with all carriers or mobile network operators

Note: To create an ALMS account, visit www.sierrawireless.com/products-and-solutions/routers-gateways/alms/register.

To configure the RX55:

1. Open a browser window, connect to AirVantage (e.g. na.airvantage.net, eu.airvantage.net), and log in to ALMS. Your ALMS account Dashboard is displayed.
2. Select Monitor > Systems to display your registered devices.
3. Find your RX55 router in the list, then click the router name to display the system details.
4. Click the Configuration button to display the configuration interface.
5. Make and save any required configuration changes. These changes will be applied to the RX55 router the next time it connects to ALMS.

For help with ALMS, view the user guide at source.sierrawireless.com/airvantage/alms/.

Reboot the RX55 Router

To reboot the RX55 router, use one of the following methods:

- On the router, press the Reset button for 1–5 seconds. (Release the button when the Power LED flashes green.)
- In AirLink OS, click the REBOOT NOW button under System > Admin > Reboot.

Reset the RX55 Router to Factory Default Settings

To reset the router to the factory default settings:

- On the router, press the Reset button for more than 5 seconds. (Release the button when the Power LED flashes red.)
Once the LEDs resume their normal operating behavior, the reset is complete.
- In AirLink OS, go to System > Admin > Reset Settings and click the RESET SETTINGS button.

Tip: In AirLink OS, you can configure the RX55 router to revert to a custom settings template when the router is reset to the factory default settings. See the RESET CONFIGURATION TYPE list in AirLink OS (System > Admin > Reset Settings).

3: Specifications at a Glance

This chapter provides the specifications for the RX55 router.

Certification and Interoperability

Emissions / Immunity	<ul style="list-style-type: none"> ▪ FCC ▪ ISED Canada ▪ CE (Including EMC Test case for vehicle installation EN301489) ▪ ACMA RCM
Safety	<ul style="list-style-type: none"> ▪ CB Scheme ▪ UL 62368-1
Industry Certification for Vehicles	<ul style="list-style-type: none"> ▪ E-Mark (UN ECE Regulation 10.04), ISO7637-2 ▪ SAE J1455 (Shock & Vibration)
Environmental Compliance	<ul style="list-style-type: none"> ▪ RoHS 2011/65/EU (RoHS 2) ▪ WEEE ▪ REACH ▪ Halogen-free PCB
GSM/UMTS Certifications	<ul style="list-style-type: none"> ▪ PTCRB ▪ GCF-CC ▪ RED
Hazardous Environments	<ul style="list-style-type: none"> ▪ Class 1 Div 2 – Ambient temperatures of -30°C to +60°C ▪ IECEx & ATEX

Environmental Testing

Test Method	Category	Description
MIL-STD-810G, Test method 514.6 IEC 60068-2-64	Vibration	Frequency range: 10 Hz–150 Hz Spectrum level: 2.24G on all axes for 8 hours/axis Operating mode: powered on
MIL-STD-810G, Test method 516.6	Mechanical Shock	Half-sine 40G, 15–23 ms, (+/-X, +/-Y, +/-Z directions, 10 times per axis) Operating mode: powered on
MIL-STD-810G, Test methods 501.5, 502.5	Temperature	Rugged category: -30 °C to 70 °C 2-hour soak each temp high/low 3 cycles ramp <= 3 °C/minute Operating mode: powered on

Test Method	Category	Description
MIL-STD-810G, Test methods 501.5, 502.5	Temperature	Rugged category: -40 °C to 85 °C 2-hour soak each temp high/low 50 cycles ramp <= 3 °C/minute Operating mode: unpowered
MIL-STD-810G, Test method 507.5	Humidity	10 × 48-hour cycles: <ul style="list-style-type: none"> ▪ 4-hour ramp to 60 °C (95% humidity), hold 8 hours ▪ 4-hour ramp down to 30 °C (85% to 95% relative humidity), hold 21 hours ▪ 1-hour ramp down to 20 °C, hold 4 hours ▪ 1-hour ramp up to 30 °C, hold 5 hours Operating mode: powered on
IEC 60529	Water Resistance	Subject to spraying water. Water sprayed at an angle up to 60° on either side of the vertical for 10 minutes. Operating mode: unpowered
IEC 61000-4-2	Electrostatic Discharge	+/-8 kV (Contact), +/-15 kV (Air) +/-15 kV (Air at antenna connector) Operating mode: powered on
IEC 60068-2-32	Free Fall Test	1 m drop height 6 drops onto concrete, 2 per axis: X, Y, Z Operating mode: unpowered
IEC 60068-2-70 Part 2, Test Xb	Marking	The markings are rubbed with water for 10 cycles, then with lubricating oil for 10 cycles. Operating mode: unpowered
ISTA 2A 2001, test categories 1, 4, 5, & 6	Package	In shipping packaging. Cargo vibration and drop test.
IP rating	IP64	

Reliability Specifications

The RX55 router has an MTBF (Ground Benign, 25°C) as follows:

- RX55 North America: 878875 hours (100.2 years)
- RX55 EMEA-APAC: 933291 hours (106.4 years)

MTBF calculations are performed per:

- Telcordia “Reliability Prediction Procedure for Electronic Equipment” document number SR-332, Method I, Issue 3

Included Radio Module Firmware

For carrier certification, please see the Tech Spec at sierrawireless.com.

RX55 NA:

- AT&T
- Verizon
- T-Mobile
- Generic

RX55 EMEA/APAC:

- Telstra (planned)
- Generic

Host Interfaces

Antenna connectors	<ul style="list-style-type: none"> ▪ Base model: <ul style="list-style-type: none"> • Cellular (LTE) SMA × 2 • Active GNSS ▪ Wi-Fi model: <ul style="list-style-type: none"> • Cellular (LTE) SMA • Active GNSS • Wi-Fi × 2
USB	<p><i>Note: Do not use the USB port in a potentially explosive environment.</i></p> <hr/> <ul style="list-style-type: none"> ▪ USB 2.0 Micro-AB connector complies with USB Version 2.0 for high speed operation ▪ Can be configured to operate in one of two modes: <ul style="list-style-type: none"> • Virtual Ethernet Port: The RX55 behaves as if the PC were connected to an Ethernet port, allowing access to the Internet and the RX55's internal web server. This is the default setting. • Virtual Serial Port: The RX55 behaves as if it was connected to a standard serial port. <p>By default, the USB port is configured as a virtual Ethernet port.</p> ▪ A Windows driver must be installed on the PC in order to support USB use. The drivers are available for download on Semtech's support web site: source.sierrawireless.com/resources/airlink/software_downloads/airlink_usb_driver/ ▪ The AirLink OS documentation contains the details of USB mode configuration and driver installation. See this page for more information. ▪ Semtech recommends you: <ul style="list-style-type: none"> • Use a USB 2.0 cable • Connect directly to your computer for best throughput.

<p>Ethernet</p>	<ul style="list-style-type: none"> ▪ 10/100/1000Base-T RJ-45 Ethernet ▪ IEEE 802.3 Ethernet specification for 1000 Mbps speed (Gigabit Ethernet) with fallback to 100 or 10 Mbps (Cat 5e or Cat 6 cable is required for Gigabit Ethernet) ▪ Auto-crossover support ▪ Auto-negotiation detects the speed of the connecting device
<p>Serial Port</p>	<ul style="list-style-type: none"> ▪ 9-pin RS232 serial port connects directly to most computers or other devices with a standard serial straight-through cable <hr/> <p><i>Note: If you have a DCE device, you need to use a null modem (cross-over) cable.</i></p> <hr/> <ul style="list-style-type: none"> ▪ Operational as single 8-wire serial port or 2 × 4-wire serial port (requires a DB9 Y cable) <ul style="list-style-type: none"> • For pin-out information, see Serial Port on page 21 ▪ Used for connecting serial devices and configuration ▪ Complies with the EIA RS232D specification for DCE equipment ▪ Output driver levels swing from -7 VDC to +7 VDC with normal loading

SIM Card Interface

- The RX55 has two 6-pin SIM sockets for a mini-SIM (2FF) SIM cards, operated at 1.8 V/3.3 V.
- This interface is compliant with the applicable 3GPP standards for USIM.

Operating Voltage

By default, the router is configured to enter Standby mode at 9 V and resume operating at 10.5 V. If you want to operate the router at less than 9 volts, power it on using at least 10.5 V, log in to AirLink OS and adjust the Standby mode settings.

The maximum ripple voltage to guarantee analog input accuracy must be 100 mVpp.

Power Specifications

Table 3-1: Power Supply Specifications

Pin	Name	Specification	Parameter	Minimum	Maximum
1	VCC	Voltage range	VCC	7 V	36 V

Table 3-2: Ignition Sense Specifications

Pin	Name	Input Impedance (Typ)	Specification	Parameter	Minimum	Maximum
3	IS (Input only)	80 k Ω (minimum)	Input low state voltage (maximum)	V_{IL}	—	1.0 V
			Input high state voltage (minimum guaranteed)	V_{IH}	3.3 V	V_{in}

*Note: If you do not connect this pin to the ignition, you **MUST** connect it to the positive terminal of your power supply or battery. The device looks for a qualified voltage on this pin as part of the power up sequence. If it doesn't see it, the device will not turn on. If you are using a Semtech AC power adapter, the connection is inside the cable.*

GNSS Specifications

Table 3-3: GNSS Specifications^a

Parameter/feature	Description
Satellite channels	Maximum 30 channels (16 GPS, 14 GLONASS), simultaneous tracking
Protocols	NMEA 0183 V3.0
Acquisition time ^b	Hot start: 1 s Warm start: 29 s Cold start: 32 s
Accuracy	Horizontal: < 5 m (50%); < 9 m (95%)

Table 3-3: GNSS Specifications^a (Continued)

Parameter/feature	Description
Sensitivity	Tracking ^c : -160 dBm Acquisition ^d (Assisted): -158 dBm Acquisition (Standalone): -145 dBm
Operational limits	Altitude < 18288 m (60,000 ft), or Velocity < 1852 km/h (1000 knots) (Either limit may be exceeded, but not both.)

- a. Preliminary values, pending validation
- b. Acquisition times measured with signal strength = -135 dBm
- c. Tracking sensitivity is the lowest GNSS signal level for which the device can still detect an in-view satellite 50% of the time when in sequential tracking mode.
- d. Acquisition sensitivity is the lowest GNSS signal level for which the device can still detect an in-view satellite 50% of the time.

Table 3-4: GNSS DC Bias Voltage

Signal	Description	Current/Voltage		
		Minimum	Typical	Maximum
GNSS Signal	Active bias on GNSS port	50 mA	75 mA	100 mA
	Maximum voltage output at 75 mA	—	—	3.3 V

GNSS Bands Supported

Table 3-5: GNSS Bands Supported

Band	Frequency
GPS	1575.42 MHz
GLONASS	1602 MHz
BeiDou	1561.098 MHz
Galileo	1575.42 MHz
QZSS	1575.42 MHz

Protocols

- Network: TCP/IP, UDP/IP, DNS
- Routing: NAT, Host Port Routing, DHCP
- Applications: SMS, NTP
- Serial: TCP/UDP PAD mode
- GNSS: NMEA 0183 V3.0, TAIP

Wi-Fi Performance

Technology	Frequency	MIMO	20 MHz ^a	40 MHz ^a	80 MHz ^a
802.11n	2.4 GHz	1 × 1	72 Mbps		
	5 GHz	1 × 1	100 Mbps	150 Mbps	
802.11ac	5 GHz	1 × 1	87 Mbps	200 Mbps	433 Mbps

a. Theoretical maximum performance. Actual data rates vary.

Wi-Fi Channels Supported

Note: An issue exists where the RX55 Wi-Fi client cannot connect to a hidden SSID. Ensure that any SSIDs to which you want the router to connect are visible to the router.

Important: *Note that AirLink OS enables increased Wi-Fi channel support via router geolocation, which identifies the country in which the router is currently located. Geolocation fixes are obtained via a cellular network connection or a GNSS position fix. If a geolocation fix indicates the router is operating in a supported country, the 5 GHz channels for that country can be used by the router. (5 GHz Wi-Fi is only supported when the router is geolocated.) If a geolocation fix is not obtained (i.e., a fix cannot be obtained from either a cellular connection or a GNSS position fix), Wi-Fi channel support is limited to the most restrictive region (USA—FCC 2.4 GHz channels).*

	Channel	Frequency (GHz)	20 MHz	40 MHz	80 MHz
2.4 GHz	1	2.412	✓		
	2	2.417	✓		
	3	2.422	✓		
	4	2.427	✓		
	5	2.432	✓		
	6	2.437	✓		
	7	2.442	✓		
	8	2.447	✓		
	9	2.452	✓		
	10	2.457	✓		
	11	2.462	✓		

	Channel	Frequency (GHz)	20 MHz	40 MHz	80 MHz
5 GHz	36	5.180	✓	✓	✓
	40	5.200	✓	✓	✓
	44	5.220	✓	✓	✓
	48	5.240	✓	✓	✓
	149	5.745	✓	✓	✓
	153	5.765	✓	✓	✓
	157	5.785	✓	✓	✓
	161	5.805	✓	✓	✓
	165	5.825	✓		

Wi-Fi Antenna Gain

The AirLink RX55 is compliant with the RF exposure requirements at 20 cm separation distance specified in EN 62311:2008 and 1999/519/EC for mobile exposure conditions, provided the maximum antenna gain does not exceed the limits given in the table below.

Table 3-6: Maximum Wi-Fi Antenna Gain

Frequency Band	Maximum Antenna Gain
2.4 GHz	3.25 dBi
5 GHz	5 dBi

Wi-Fi Output Power

16 dBm

Radio Frequency Bands

Use the following table as a guide to the radio frequencies and transmit power supported by the RX55 radio modules.

To determine which radio module your router has, refer to the label on the bottom of the router

Table 3-7: EM7411 LTE-A Frequency Bands

Band	Frequency (Tx)	Frequency (Rx)
B2	1850–1910 MHz	1930–1990 MHz
B4	1710–1755 MHz	2110–2155 MHz
B5	824–849 MHz	869–894 MHz
B7	2500–2570 MHz	2620–2690 MHz
B12	699–716 MHz	729–746 MHz
B13	777–787 MHz	746–756 MHz
B14	788–798 MHz	758–768 MHz
B25	1850–1915 MHz	1930–1995 MHz
B26	814–849 MHz	859–894 MHz
B41	2496–2690 MHz (TDD)	
B42	3400–3600 MHz (TDD)	
B43	3600–3800 MHz (TDD)	
B48	3550–3700 MHz (TDD)	
B66	1710–1780 MHz	2110–2200 MHz
B71	663–698 MHz	617–652 MHz

Table 3-8: EM7411 WCDMA Frequency Bands Support

Band	Frequency (Tx)	Frequency (Rx)
Band 2	1850–1910 MHz	1930–1990 MHz
Band 4	1710–1755 MHz	2110–2155 MHz
Band 5	824–849 MHz	869–894 MHz

Note: Values in the following table are preliminary, pending transceiver matching/testing.

Table 3-9: EM7411 Conducted Tx (Transmit) Power Tolerances

Bands	Conducted Tx power	Notes
LTE		
LTE bands 2, 4, 25, 26, 66	22.5 dBm ± 1 dB	
LTE band 5	Single cell: 22.5 dBm ± 1 dB UL CA: 23.3 dBm ± 1 dB	0.8 dB offset for UL CA hardcoded by chipset manufacturer
LTE bands 7, 41, 42, 43, 48	Single cell: 22 dBm ± 1 dB UL CA: 22.8 dBm ± 1 dB	
LTE bands 12, 13, 14, 71	23 dBm ± 1 dB	
UMTS		
Band 2 (UMTS 1900 12.2 kbps)	23 dBm ± 1 dB	Connectorized (Class 3)
Band 4 (AWS 1700/2100 12.2 kbps)	23 dBm ± 1 dB	
Band 5 (UMTS 850 12.2 kbps)	23 dBm ± 1 dB	

Note: Values in the following table are preliminary, pending transceiver matching/testing.

Table 3-10: EM7421 LTE-A Frequency Bands

Band	Frequency (Tx)	Frequency (Rx)
B1	1920–1980 MHz	2110–2170 MHz
B3	1710–1785 MHz	1805–1880 MHz
B7	2500–2570 MHz	2620–2690 MHz
B8	880–915 MHz	925–960 MHz
B20	832–862 MHz	791–821 MHz
B28	703–748 MHz	758–803 MHz
B32	n/a	1452–1496 MHz
B38	2570–2620 MHz (TDD)	
B40	2300–2400 MHz (TDD)	
B41	2496–2690 MHz (TDD)	
B42	3400–3600 MHz (TDD)	
B43	3600–3800 MHz (TDD)	

Table 3-11: EM7421 WCDMA Frequency Bands Support

Band	Frequency (Tx)	Frequency (Rx)
Band 1	1920–1980 MHz	2110–2170 MHz
Band 5	824–849 MHz	869–894 MHz
Band 8	880–915 MHz	925–960 MHz

Table 3-12: EM7421 Conducted Tx (Transmit) Power Tolerances

Bands	Conducted Tx power	Notes
LTE		
LTE bands 1, 3	22.5 dBm \pm 1 dB	
LTE bands 7, 38, 40, 41, 42, 43	22 dBm \pm 1 dB	
LTE bands 8, 20, 28	23 dBm \pm 1 dB	
UMTS		
Band 1 (IMT 2100 12.2 kbps)	23 dBm \pm 1 dB	Connectorized (Class 3)
Band 5 (UMTS 850 12.2 kbps)	22 dBm \pm 1 dB	
Band 8 (UMTS 900 12.2 kbps)	23 dBm \pm 1 dB	

Carrier Aggregation Combinations

LTE-Advanced uses carrier aggregation to increase bandwidth. The following tables show the carrier aggregation combinations.

Table 3-13: EM7411 Carrier Aggregation Downlink Combinations

1 Band / 2CC	2 Bands / 2CC
CA_2A-2A	CA_2A-5A
CA_2C	CA_2A-7A
	CA_2A-12A
	CA_2A-13A
	CA_2A-14A
	CA_2A-71A

Table 3-13: EM7411 Carrier Aggregation Downlink Combinations (Continued)

1 Band / 2CC	2 Bands / 2CC
CA_4A-4A	CA_4A-5A
	CA_4A-7A
	CA_4A-12A
	CA_4A-13A
	CA_4A-71A
CA_5B	CA_5A-66A
CA_7A-7A	CA_7A-12A
CA_7B	
CA_7C	
CA_12B	CA_12A-66A
	CA_13A-66A
	CA_14A-66A
CA_25A-25A	CA_25A-26A
	CA_26A-41A
CA_41A-41A	
CA_41C	
CA_42A-42A	
CA_42C	
CA_43C	
CA_48A-48A	
CA_48C	
CA_66A-66A	CA_66A-71A
CA_66B	
CA_66C	

Table 3-14: EM7421 Carrier Aggregation Downlink Combinations

1 Band / 2CC	2 Bands / 2CC
	CA_1A-8A
CA_1C	CA_1A-20A
	CA_1A-28A

Table 3-14: EM7421 Carrier Aggregation Downlink Combinations (Continued)

1 Band / 2CC	2 Bands / 2CC
CA_3A-3A	CA_3A-7A
CA_3C	CA_3A-8A
	CA_3A-20A
	CA_3A-28A
CA_7A-7A	CA_7A-8A
CA_7B	CA_7A-20A
CA_7C	CA_7A-28A
	CA_20A-32A
CA_38C	
CA_40A-40A	
CA_40C	
CA_41A-41A	
CA_41C	
CA_42A-42A	
CA_42C	
CA_43C	

Mechanical Specifications

- Housing — The RX55 router is made of ruggedized powder-coated aluminum.
- RoHS — The RX55 router complies with the Restriction of Hazardous Substances Directive (RoHS). This directive restricts the use of six hazardous materials in the manufacture of various types of electronic and electrical equipment.

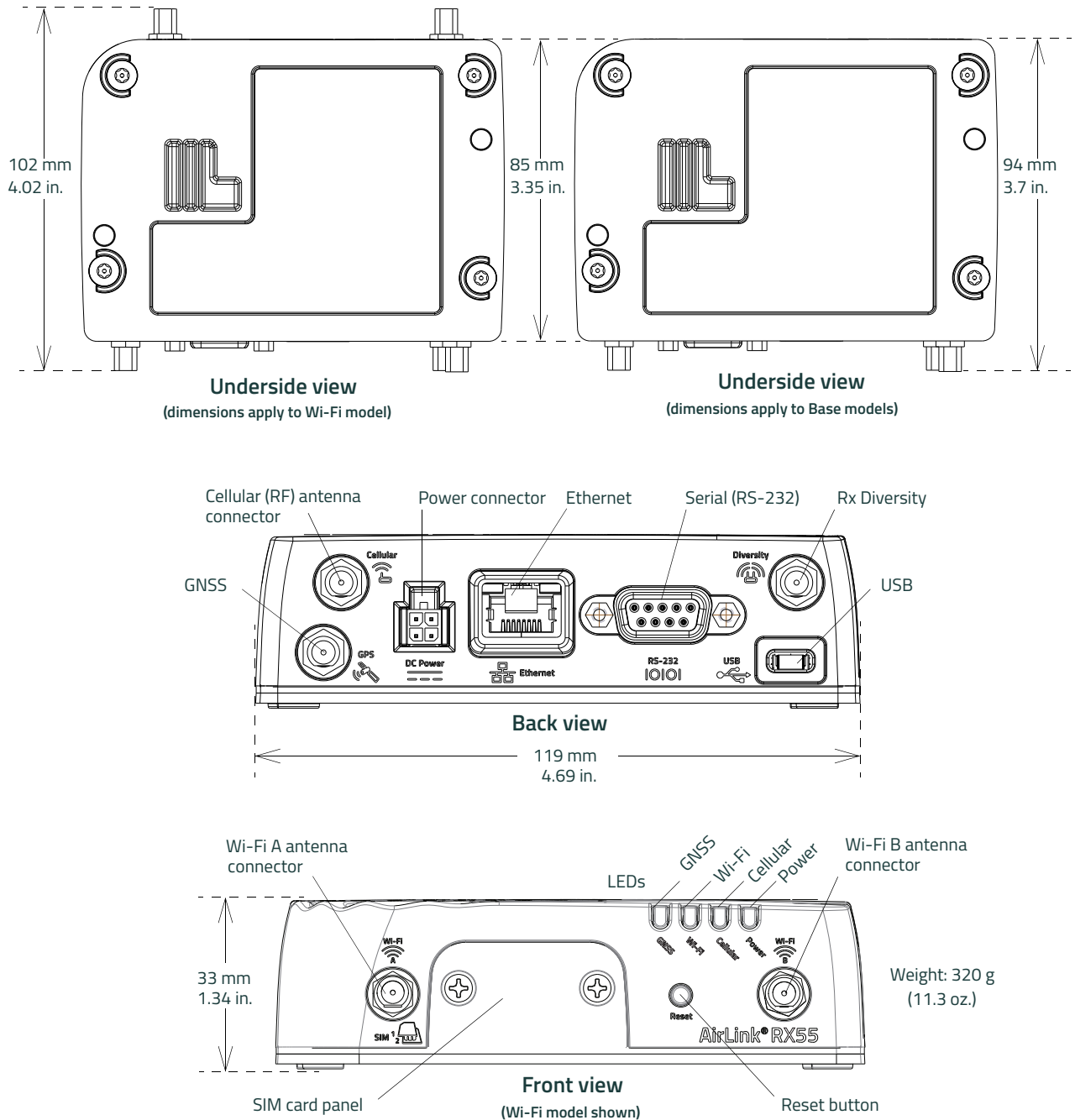

Figure 3-1: RX55 Router Mechanical Specifications

Screw Torque Settings

- DIN rail mount screws: 1.1 N-m (10 in-lb)
- Antennas: Finger tight (5–7 in-lb) is sufficient. The max torque should not go beyond 1.1 N-m (10 in-lb).

4: Regulatory Information

Important Information for North American Users

Note: This equipment has been tested and found to comply with the limits for a Class A digital device, pursuant to part 15 of the FCC Rules. These limits are designed to provide reasonable protection against harmful interference when the equipment is operated in a commercial environment. This equipment generates, uses, and can radiate radio frequency energy and, if not installed and used in accordance with the instruction manual, may cause harmful interference to radio communications. Operation of this equipment in a residential area is likely to cause harmful interference, in which case the user will be required to correct the interference at his own expense.

Warning: Changes or modifications to this device not expressly approved by Semtech could void the user's authority to operate this equipment.

RF Exposure

In accordance with FCC/IC requirements of human exposure to radio frequency fields, the radiating element shall be installed such that a minimum separation distance of 20 cm should be maintained from the antenna and the user's body.

Warning: This product is only to be installed by qualified personnel.

To comply with FCC/IC regulations limiting both maximum RF output power and human exposure to RF radiation, the maximum antenna gain must not exceed the specifications listed below for the device used.

Antennas listed at www.sierrawireless.com/router-solutions/antennas/ have been designed for use with the RX55 platform. Antennas of the same types within the defined gain limits may be used with the RX55.

This device can operate in collocation with cellular radios not exceeding the specifications in the following table.

Table 4-1: Antenna Gain Specifications

Device	Operating Mode	Tx Freq Range (MHz)		Max Conducted Power (dBm)	Maximum Antenna Gain (dBi)	
					Standalone	Collocated
EM7411	WCDMA Band 2	1850	1910	24	6	6
	WCDMA Band 4	1710	1755	24	6	6
	WCDMA Band 5	824	849	24.3	6	4
	LTE B2	1850	1910	24	6	6
	LTE B4	1710	1755	24	6	6
	LTE B5	824	849	24.3	6	4
	LTE B7	2500	2570	23.8	9	4
	LTE B12	699	716	24	6	4
	LTE B13	777	787	24	6	4
	LTE B14	788	798	24	6	4
	LTE B25	1850	1915	24	6	6
	LTE B26	814	849	24	6	4
	LTE B41	2496	2690	23.8	9	8
	LTE B42	3450	3650	23.8	-0.8	-0.8
	LTE B43					
	LTE B48*	3550	3700	23.8	-0.8	-0.8
LTE B66	1710	1780	24	6	6	
LTE B71	663	698	24	6	3	
Collocated transmitters				Maximum EIRP (dBm)		
	WLAN 2.4 GHz	2400	2500	30		
	WLAN 5 GHz	5150	5850	30		
	Bluetooth	2400	2500	16		

EU

Semtech hereby declares the AirLink RX55 devices are in compliance with the essential requirements and other relevant provisions of Directive 2014/53/EU.

The RX55 devices display the CE mark.



Warning: Changes or modifications to this device not expressly approved by Semtech could void the user's authority to operate this equipment.

Warning: This product is only to be installed by qualified personnel.

Declaration of Conformity

The Declaration of Conformity made under Directive 2014/53/EU is available for viewing at:

source.sierrawireless.com/resources/airlink/certification_and_type_approval/rx55_lte-a_ce_declaration_of_conformity/

IECEX Compliance

Special condition of safe use:

- Equipment shall be installed in an Ex certified tool secured enclosure which provides a minimum ingress protection of IP64. It must be mounted with mounting screws on a flat surface, or optional DIN rail mounting bracket with the DIN rail clip to a horizontal DIN rail and the spring clip at the bottom.

This certification applies to the following Product SKUs:

- 1104927
- 1104928 (Wi-Fi)
- 1104934 (Wi-Fi Plus)
- 1104929
- 1104930 (Wi-Fi)
- 1104933 (Wi-Fi Plus)

RX55 NA SKUs contain FCC ID: N7NEM74B

RX55 NA SKUs with Wi-Fi contain FCC ID: N6C-SDPAC

Applicable Standards

- EN IEC 60079-0:2017, Edition 7.0
- IEC 60079-7:2017, Edition 5.1
- EN 60079-0:2018
- EN 60079-7:2015 +A1:2018

- IECEX ETL 22.0035X
- ETL22ATEX0194X
- ETL22CA105064761X

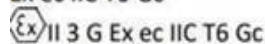
Ex ec IIC T6 Gc

-30°C ≤ Tamb ≤ +60°C

Warning: Do not separate when energized.

WEEE Notice



If you purchased your AirLink RX55 device in Europe, please return it to your dealer or supplier at the end of its life. WEEE products may be recognized by their wheeled bin label on the product label.

A: Accessories

DC Power Cable (Black Connector)

Table A-1: DC Power Cable

DC Power Cable	
Part Number	2000522
Product Release	2016

Components:

- ① 1 UL2464 20 AWG × 4 core cable
- ② 4 Molex female crimp terminals /AWG 20-24, 250 V, 4 A Max, phosphor bronze tin-plated (part number 43030-0001)
- ③ 1 Molex male 2×2P Ph: 3.0 mm housing, 250 V, 5 A max, PA65 black UL94V-0 (part number 43025-0408)

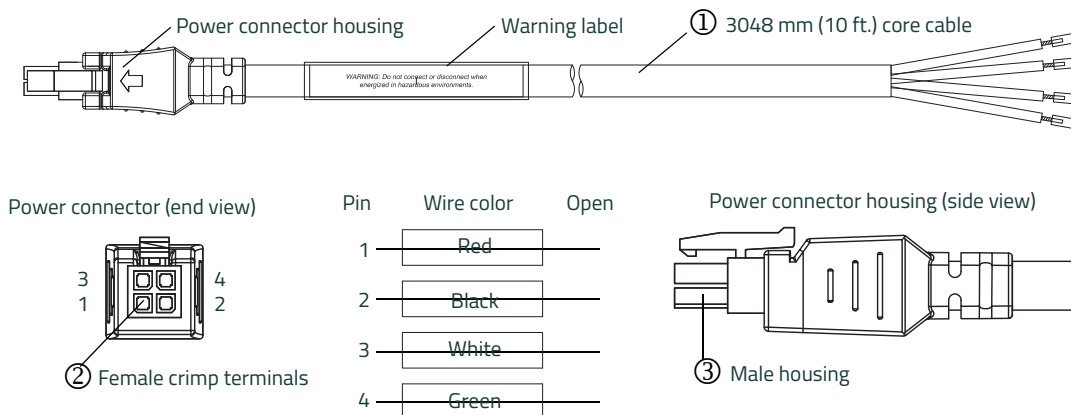

Figure A-1: DC Cable Specifications

AC Power Adapter (Black Connector)

Note: Please note that the AC power adapter is not available for sale in New Zealand (as of June 1, 2018).

AC Power Adapter	
Part Number	2000579
Product Release Date	2016

AC Power Adapter Input

Table A-2: Input Specifications

	Minimum	Typical	Maximum
Input			
Input Voltage	90 VAC	100–240 VAC	264 VAC
Input Frequency	47 Hz	50/60 Hz	63 Hz
<p><i>Note: Input voltage range is 90 VAC to 264 VAC. Maximum input current is 500 mA at 100–240 VAC. Inrush current will not exceed 75 A at 100–240 VAC input and maximum load from a cold start at 25°C.</i></p>			

AC Power Adapter Output

Table A-3: AC Power Adapter Output Specifications

	Minimum	Typical	Maximum	Test conditions
Output Voltage	11.4 VDC	12.0 VDC	12.6 VDC	0 ~ 1.5 A loading

AC Power Adapter Environmental Specifications

Table A-4: AC Power Adapter Environmental Specifications

Operating	
Operating Temperature	0°C ~ 40°C (operates normally)
Relative Humidity	10% ~ 90%
Altitude	Sea level to 2,000 meters
Vibration	1.0 mm, 10–55 Hz, 15 minutes per cycle for each axis (X, Y, Z)
Non-operating	
Storage Temperature	-30°C ~ 70°C
Relative Humidity	10% ~ 90%
Vibration and Shock	MIL-STD-810D, method 514

AC Power Adapter Reliability and Quality Control

AC Power Adapter MTBF

When the power supply is operating within the limits of this specification, the MTBF is at least 200,000 hours at 25°C (MIL-HDBK-217F).

Note: For router MTBF, see [Reliability Specifications](#) on page 42.

AC Power Adapter Safety Standards

The power supply is certified with the following international regulatory standards:

Table A-5: AC Power Adapter Safety Standards

Regulatory Agency	Country or Region	Certified	Standard
UL	USA	Approved	UL60950-1
GS	Europe	Approved	EN60950-1
CE	Europe	Approved	EN60950-1
SAA	Australia	Approved	AS/NZS 60950
CCC	China	Approved	GB4943
CUL	Canada	Approved	CSA C22.2 NO.60950-1

AC Power Adapter EMC Standards

The power supply meets the radiated and conducted emission requirements for EN55022, FCC Part 15, Class B, GB9254.

AC Power Adapter Hazardous Substances

- EU Directive 2011/65/EU “RoHS”
- EU Directive 2012/19/EU “WEEE”
- REACH

AC Power Adapter Energy Efficiency

The AC adapter complies with International Efficiency Levels, as shown in [Table A-6](#).

Table A-6: AC Adapter Energy Efficiency

Supplied Input	No-load power consumption	Average active mode efficiency	International Efficiency Level
115 VAC, 60 Hz	Less than 0.1 W	Greater than 85%	VI
230 VAC, 50 Hz	Less than 0.3 W	Greater than 80.4%	V

Dual Serial Port Adapter Cable

Note: This cable is compatible with non-Wi-Fi models only.

Dual Serial Port Adapter Cable	
Part Number	6001238
Product Release	2019

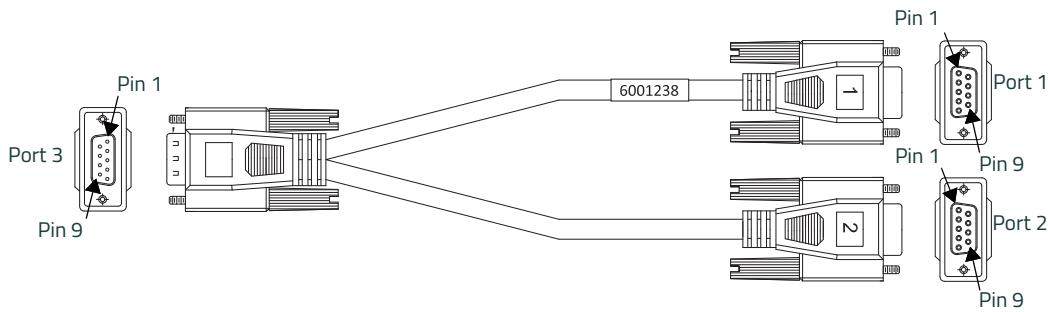

Table A-7: Serial Connector Pin Assignment

Description	Type	Port 3 Pin	Port 1 Pin	Port 2 Pin
Port 2 Clear To Send	OUT	1	—	8
Port 1 Transmit Data	OUT	2	2	—
Port 1 Receive Data	IN	3	3	—
Port 2 Receive Data	IN	4	—	3
Main GND. Connected internally to BOARD GND	GND	5	5	5
Port 2 Transmit Data	OUT	6	—	2
Port 1 Ready To Send	IN	7	7	—
Port 1 Clear To Send	OUT	8	8	—
Port 2 Ready To Send	IN	9	-	7

Serial CAN Y-Cable

The Serial CAN Y-Cable allows you to connect the RX55 to another serial-based system and/or to a vehicle bus interface cable.

Note: This cable is compatible with Wi-Fi models only.

Serial CAN Y-Cable	
Part Number	6001479
Product Release	2022

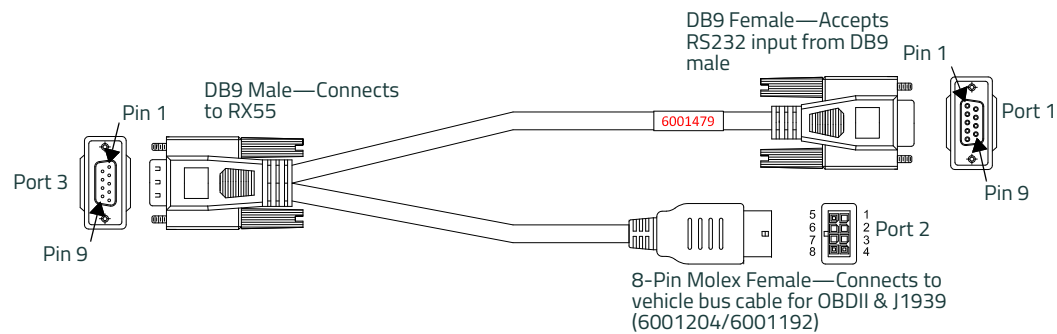

Table A-8: Serial CAN Y-Cable Pin Assignment

Pin #	Port 3 Pins	Port 1 Pins	Port 2 Pins
1	DCD	—	—
2	TXD	TXD	—
3	RXD	RXD	—
4	DTR	—	CAN_H
5	GND	GND	CAN_L
6	DSR	—	—
7	RTS	RTS	—
8	CTS	CTS	GND
9	Not used	—	—
Shell	GND	GND	—

Index

A

- Accessories, [13](#)
- accuracy (GNSS), [45](#)
- ACEmanager, [10](#)
- acquisition time (GNSS), [45](#)
- AirLink Management Service, [10](#)
- Analog input, [32](#)
- Antenna
 - Connecting, [18](#)
 - Recommended separation, [20](#)
 - Safe mounting, [16](#)

B

- bands supported, RF
 - LTE, [49](#), [50](#), [51](#)

C

- Cable strain relief, [23](#)
- Cables, connecting, [20](#)
- Carrier aggregation, [51](#)
- Certification
 - Mobile Network Operator, [43](#)
- conducted Tx power tolerances, [50](#), [51](#)
- Configuring the gateway, [10](#)
- Current sink, [33](#)

D

- DC cable wires, [24](#)
- DC voltage transients, [23](#)
- Description, product, [8](#)
- Digital I/O specifications, [45](#)
- Digital output, [34](#)
- Dual SIM, [13](#)

E

- Ethernet
 - LEDs, [38](#)
 - Specification, [21](#)
- Ethernet, virtual Ethernet port, [21](#)

F

- Features, [8](#)
- frequency band support
 - LTE, [49](#), [50](#), [51](#)
- Fusing, [23](#)

G

- GNSS, [45](#)
- GNSS, bands supported, [46](#)
- GPS
 - specifications, [45](#)
- Grounding the chassis, [18](#)

H

- Host Interfaces, [43](#)

I

- I / O Configuration, [28](#)
- Input
 - Analog, [32](#)
 - Dry contact switch, [31](#)
 - Ignition switch, [30](#)
- Installation
 - Connect data cables, [20](#)
 - Connect power cable, [23](#)
 - Connecting antennas, [18](#)
 - Fixed (with I/O), [28](#)
 - Fixed (without I/O), [27](#)
 - Insert SIM cards, [15](#)
 - overview, [14](#)
 - Tools and materials required, [14](#)
 - Vehicle, [26](#)

L

- LED
 - Description of LED, [34](#)
- LTE
 - frequency band support, [49](#), [50](#), [51](#)

M

- Mounting
 - Brackets, [16](#)
 - DIN rail, [17](#)
 - kits, [17](#)
 - On DIN rail, [17](#)
- MTBF, [42](#)

N

- Network Operator Switching, [13](#)

O

- Open drain, [34](#)
- Operating voltage, [45](#)
- Output, digital, [34](#)

P

- Ports, [8](#)
- Power
 - Connecting, [23](#)
 - Connector, [23](#)
 - input specifications, [45](#)
 - Modes, [10](#)
 - power supply specifications, [45](#)
- Power consumption, sample scenarios, [12](#)
- Power saving features, [11](#)

power tolerances, conducted Tx, [50](#), [51](#)
Protocols, [46](#)
Pull-up resistor, [31](#)
Pulse counter, [29](#)

R

Rebooting, [40](#)
Regulatory information, [56](#)
Regulatory specifications, [63](#)
Reliability, [42](#)
Reset to factory default settings, [40](#)
RF bands supported
 LTE, [49](#), [50](#), [51](#)
RF specifications, [18](#)

S

Screw Torque, [55](#)
Serial connector pin-out, [22](#), [64](#), [65](#)
Serial port, [21](#), [44](#)
 Virtual serial port, [21](#)
SIM cards, insert, [15](#)
SIM, dual, [13](#)
Specifications, [41](#)
 Environmental, [41](#)
 GNSS, [45](#)
 Regulatory, [63](#)
 RF, [18](#)
specifications
 GPS, [45](#)
Standards, regulatory, [63](#)

T

Tools required for install, [14](#)
Tx power tolerances, conducted, [50](#), [51](#)

U

USB, [21](#)

V

Vehicle installation
 Alternate, [26](#)
 Recommended, [26](#)
Virtual port, Ethernet or serial, [21](#)
Voltage, input and ripple range, [45](#)

W

Warranty, [13](#)
Wi-Fi performance, [47](#)
Wiring diagrams, [26](#)