



# AirPrime HL6528RDx

## Product Technical Specification



**SIERRA**  
WIRELESS®

4117701  
12.0  
June 05, 2019

## Important Notice

Due to the nature of wireless communications, transmission and reception of data can never be guaranteed. Data may be delayed, corrupted (i.e., have errors) or be totally lost. Although significant delays or losses of data are rare when wireless devices such as the Sierra Wireless modem are used in a normal manner with a well-constructed network, the Sierra Wireless modem should not be used in situations where failure to transmit or receive data could result in damage of any kind to the user or any other party, including but not limited to personal injury, death, or loss of property. Sierra Wireless accepts no responsibility for damages of any kind resulting from delays or errors in data transmitted or received using the Sierra Wireless modem, or for failure of the Sierra Wireless modem to transmit or receive such data.

## Safety and Hazards

Do not operate the Sierra Wireless modem in areas where cellular modems are not advised without proper device certifications. These areas include environments where cellular radio can interfere such as explosive atmospheres, medical equipment, or any other equipment which may be susceptible to any form of radio interference. The Sierra Wireless modem can transmit signals that could interfere with this equipment. Do not operate the Sierra Wireless modem in any aircraft, whether the aircraft is on the ground or in flight. In aircraft, the Sierra Wireless modem **MUST BE POWERED OFF**. When operating, the Sierra Wireless modem can transmit signals that could interfere with various onboard systems.

---

*Note: Some airlines may permit the use of cellular phones while the aircraft is on the ground and the door is open. Sierra Wireless modems may be used at this time.*

---

The driver or operator of any vehicle should not operate the Sierra Wireless modem while in control of a vehicle. Doing so will detract from the driver or operator's control and operation of that vehicle. In some states and provinces, operating such communications devices while in control of a vehicle is an offence.

## Limitations of Liability

This manual is provided "as is". Sierra Wireless makes no warranties of any kind, either expressed or implied, including any implied warranties of merchantability, fitness for a particular purpose, or noninfringement. The recipient of the manual shall endorse all risks arising from its use.

The information in this manual is subject to change without notice and does not represent a commitment on the part of Sierra Wireless. SIERRA WIRELESS AND ITS AFFILIATES SPECIFICALLY DISCLAIM LIABILITY FOR ANY AND ALL DIRECT, INDIRECT, SPECIAL, GENERAL, INCIDENTAL, CONSEQUENTIAL, PUNITIVE OR EXEMPLARY DAMAGES INCLUDING, BUT NOT LIMITED TO, LOSS OF PROFITS OR REVENUE OR ANTICIPATED PROFITS OR REVENUE ARISING OUT OF THE USE OR INABILITY TO USE ANY SIERRA WIRELESS PRODUCT, EVEN IF SIERRA WIRELESS AND/OR ITS AFFILIATES HAS BEEN ADVISED OF THE POSSIBILITY OF SUCH DAMAGES OR THEY ARE FORESEEABLE OR FOR CLAIMS BY ANY THIRD PARTY.

Notwithstanding the foregoing, in no event shall Sierra Wireless and/or its affiliates aggregate liability arising under or in connection with the Sierra Wireless product, regardless of the number of events, occurrences, or claims giving rise to liability, be in excess of the price paid by the purchaser for the Sierra Wireless product.

## Patents

This product may contain technology developed by or for Sierra Wireless Inc.

This product includes technology licensed from QUALCOMM®.

This product is manufactured or sold by Sierra Wireless Inc. or its affiliates under one or more patents licensed from MMP Portfolio Licensing.

## Copyright

© 2019 Sierra Wireless. All rights reserved.

## Trademarks

Sierra Wireless®, AirPrime®, AirLink®, AirVantage®, WISMO®, ALEOS® and the Sierra Wireless and Open AT logos are registered trademarks of Sierra Wireless, Inc. or one of its subsidiaries.

Watcher® is a registered trademark of NETGEAR, Inc., used under license.

Windows® and Windows Vista® are registered trademarks of Microsoft Corporation.

Macintosh® and Mac OS X® are registered trademarks of Apple Inc., registered in the U.S. and other countries.

QUALCOMM® is a registered trademark of QUALCOMM Incorporated. Used under license.

Other trademarks are the property of their respective owners.

## Contact Information

Sales information and technical support, including warranty and returns	Web: <a href="http://sierrawireless.com/company/contact-us/">sierrawireless.com/company/contact-us/</a> Global toll-free number: 1-877-687-7795 6:00 am to 5:00 pm PST
Corporate and product information	Web: <a href="http://sierrawireless.com">sierrawireless.com</a>

# Document History

Version	Date	Updates
1.0	July 31, 2015	Creation
1.1	August 18, 2015	Added 1.8 ESD
		Updated: <ul style="list-style-type: none"> <li>1.3 General Features</li> <li>Figure 1 AirPrime HL6528RDx Architecture Overview</li> <li>3 Detailed Interface Specifications</li> <li>5.1.2 Using USB</li> <li>5.9.1 Microphone Audio Design</li> </ul>
		Delete 1.4 Feature Restriction
2.0	December 08, 2015	Updated: <ul style="list-style-type: none"> <li>Typo in Table 26 ADC Electrical Characteristics</li> <li>Table 54 AirPrime HL6528RDx FCC IDs</li> <li>Table 55 AirPrime HL6528RDx IC IDs</li> </ul>
3.0	March 03, 2016	Updated: <ul style="list-style-type: none"> <li>Table 9 Current Consumption</li> <li>8 Regulatory Legal Information</li> </ul>
		Deleted UIM2
4.0	May 20, 2016	Updated section 3.2 Current Consumption
4.1	May 21, 2016	Added a note after Table 22 GPIO Pad Description
	September 13, 2016	Added: <ul style="list-style-type: none"> <li>1.10 Conformance with ATEX 94/9/CE Directive</li> <li>5.5 ESD Guidelines for USB</li> </ul>
		Updated: <ul style="list-style-type: none"> <li>Table 3 GNSS Capabilities</li> <li>Table 9 Current Consumption</li> <li>Table 41 GNSS Interface Specifications</li> <li>3.21.3 GNSS Antenna Recommendations</li> <li>Figure 33 GSM Antenna Connection with Antenna Detection</li> <li>9 Ordering Information</li> </ul>
4.2	September 19, 2016	Updated Table 41 GNSS Interface Specifications
5.0	December 06, 2016	Updated: <ul style="list-style-type: none"> <li>Table 9 Current Consumption</li> <li>Table 10 Current Consumption per Power Supply (VBATT / VBATT_PA)</li> <li>Table 41 GNSS Interface Specifications</li> </ul>
6.0	June 06, 2017	Updated: <ul style="list-style-type: none"> <li>3.7 Electrical Information for Digital I/O</li> <li>3.15 PCM</li> <li>8.5 CE</li> </ul>
		Deleted 1.9.2.Regulatory
6.1	June 22, 2017	Updated 3.15 PCM
7.0	September 06, 2017	Added Table 19 Internal Resistance for Group 2 Interface (UART)

Version	Date	Updates
		Updated: <ul style="list-style-type: none"> <li>• Table 2 AirPrime HL6528RDx Features</li> <li>• Table 18 Digital I/O Electrical Characteristics – Group 2 Input/Output Current</li> </ul>
8.0	October 31, 2017	Updated Table 16 Digital I/O Electrical Characteristics – Input/Output Voltage
8.1	November 06, 2017	
9.0	January 31, 2018	Added 5.8 Power Cycle
10.0	June 12, 2018	Updated: <ul style="list-style-type: none"> <li>• 1.9.2 RoHS Directive Compliance</li> <li>• 3.20 RF Interface</li> </ul>
11.0	January 18, 2019	Updated 3.4 BAT_RTC
12.0	June 05, 2019	Updated 3.17.2 JTAG

# Contents

<b>1. INTRODUCTION .....</b>	<b>12</b>
1.1. Common Flexible Form Factor (CF <sup>3</sup> ) .....	12
1.2. Physical Dimensions .....	13
1.3. General Features .....	13
1.4. GNSS Features .....	14
1.5. Architecture .....	14
1.6. Interfaces .....	15
1.7. Connection Interface .....	15
1.8. ESD .....	16
1.9. Environmental and Certifications .....	16
1.9.1. Environmental Specifications .....	16
1.9.2. RoHS Directive Compliance .....	17
1.9.3. Disposing of the Product .....	17
1.10. Conformance with ATEX 94/9/CE Directive .....	17
1.11. References .....	18
<b>2. PAD DEFINITION .....</b>	<b>19</b>
2.1. Pad Configuration (Top View) .....	24
<b>3. DETAILED INTERFACE SPECIFICATIONS .....</b>	<b>25</b>
3.1. Power Supply .....	25
3.2. Current Consumption .....	25
3.3. VGPIO .....	27
3.4. BAT_RTC .....	28
3.5. UIM Interface .....	28
3.5.1. UIM1_DET .....	29
3.6. USB Interface .....	29
3.7. Electrical Information for Digital I/O .....	30
3.8. General Purpose Input/Output (GPIO) .....	32
3.9. Main Serial Link (UART1) .....	32
3.9.1. 8-wire Application .....	33
3.9.2. 4-wire Application .....	34
3.9.3. 2-wire Application .....	34
3.10. Power On Signal (PWR_ON_N) .....	34
3.11. Reset Signal (RESET_IN_N) .....	35
3.12. ADC .....	36
3.13. Clock Interface .....	36

---

3.14.	Analog Audio Interfaces .....	37
3.14.1.	Analog Audio Input .....	37
3.14.2.	Analog Audio Output.....	38
3.15.	PCM.....	38
3.16.	I <sup>2</sup> C Interface.....	40
3.17.	Debug Interfaces .....	40
3.17.1.	Debug Port.....	40
3.17.2.	JTAG.....	41
3.18.	PPS (HL6528RD-G and HL6528RD-G2.8V only) .....	41
3.19.	EXT_LNA_GPS_EN (HL6528RD-G and HL6528RD-G2.8V only).....	42
3.20.	RF Interface .....	42
3.20.1.	RF Connection.....	42
3.20.2.	RF Performances.....	42
3.20.3.	TX Burst Indicator (2G_TX_ON).....	43
3.21.	GNSS Interface .....	44
3.21.1.	GNSS Performances .....	44
3.21.2.	GNSS Antenna Interface .....	45
3.21.3.	GNSS Antenna Recommendations .....	45
<b>4.</b>	<b>MECHANICAL DRAWINGS.....</b>	<b>46</b>
<b>5.</b>	<b>DESIGN GUIDELINES .....</b>	<b>48</b>
5.1.	Power On Sequence .....	48
5.1.1.	Using UART1.....	48
5.1.2.	Using USB .....	49
5.2.	Module Switch-Off .....	49
5.3.	Sleep Mode Management .....	49
5.4.	ESD Guidelines for UIM Cards.....	50
5.5.	ESD Guidelines for USB.....	51
5.6.	ESD Guidelines for RF Interface .....	51
5.7.	Power Supply.....	51
5.8.	Power Cycle.....	52
5.9.	Audio Integration .....	52
5.9.1.	Microphone Audio Design.....	52
5.9.2.	Speaker Audio Design .....	54
5.9.3.	Audio Layout Guidelines.....	56
5.10.	Radio Integration .....	57
5.10.1.	GSM Antenna Integration with Antenna Detection Circuitry.....	57
5.10.2.	GNSS Active Antenna Integration .....	58
5.11.	Temperature Monitor .....	58
<b>6.</b>	<b>FLASH MEMORY ENDURANCE.....</b>	<b>59</b>
<b>7.</b>	<b>RELIABILITY SPECIFICATION .....</b>	<b>60</b>
7.1.	Reliability Compliance .....	60

7.2.	Reliability Prediction Model .....	60
7.2.1.	Life Stress Test.....	60
7.2.2.	Environmental Resistance Stress Tests.....	61
7.2.3.	Corrosive Resistance Stress Tests .....	61
7.2.4.	Thermal Resistance Cycle Stress Tests.....	62
7.2.5.	Mechanical Resistance Stress Tests.....	63
7.2.6.	Handling Resistance Stress Tests.....	64
<b>8.</b>	<b>REGULATORY LEGAL INFORMATION .....</b>	<b>65</b>
8.1.	Label .....	65
8.2.	FCC Regulations .....	65
8.3.	RF Exposure Information.....	66
8.4.	IC Regulations .....	66
8.5.	CE.....	67
<b>9.</b>	<b>ORDERING INFORMATION .....</b>	<b>68</b>
<b>10.</b>	<b>TERMS AND ABBREVIATIONS .....</b>	<b>69</b>

# >> | List of Figures

Figure 1.	AirPrime HL6528RDx Architecture Overview.....	14
Figure 2.	AirPrime HL6528RDx Module Mechanical Overview.....	15
Figure 3.	Pad Configuration.....	24
Figure 4.	UIM Implementation Example .....	29
Figure 5.	8-wire UART Application Example .....	33
Figure 6.	4-wire UART Application Example .....	34
Figure 7.	2-wire UART Application Example .....	34
Figure 8.	PWR_ON_N Connection Example with Switch.....	35
Figure 9.	PWR_ON_N Connection Example with an Open Collector Transistor .....	35
Figure 10.	MIC Input Diagram .....	37
Figure 11.	PCM Timing Waveform .....	39
Figure 12.	2G_TX_ON State during TX Burst .....	43
Figure 13.	AirPrime HL6528RDx (angular view) .....	46
Figure 14.	AirPrime HL6528RDx (side view).....	46
Figure 15.	AirPrime HL6528RDx Module (top view) .....	47
Figure 16.	AirPrime HL6528RDx Module (bottom view with dimensions).....	47
Figure 17.	PWR_ON_N Sequence with $T_{rampup}$ .....	48
Figure 18.	UART Signals during the Power ON Sequence .....	48
Figure 19.	PWR_ON_N Sequence with VGPIO Information.....	49
Figure 20.	Power OFF Sequence for PWR_ON_N, VGPIO and UART1_CTS .....	49
Figure 21.	EMC and ESD Components Close to the UIM.....	50
Figure 22.	ESD Protection for USB .....	51
Figure 23.	Voltage Limiter Example .....	51
Figure 24.	Example of a MIC Input Connection with LC Filter .....	52
Figure 25.	Example of a MIC Input Connection without LC Filter .....	52
Figure 26.	Example of a Single-Ended MIC Input Connection with LC Filter.....	53
Figure 27.	Example of a Single-Ended MIC Input Connection without LC Filter.....	54
Figure 28.	Example of a Differential Connection for SPKR.....	55
Figure 29.	Example of a Single-Ended Speaker Connection (typical implementation).....	55
Figure 30.	Audio Track Design .....	56
Figure 31.	Differential Audio Connection.....	56
Figure 32.	Single-Ended Audio Connection .....	56
Figure 33.	GSM Antenna Connection with Antenna Detection .....	57
Figure 34.	GNSS Application with Active Antenna.....	58

# >> | List of Tables

Table 1.	Supported Frequencies .....	12
Table 2.	AirPrime HL6528RDx Features.....	13
Table 3.	GNSS Capabilities.....	14
Table 4.	ESD Specifications.....	16
Table 5.	AirPrime HL6528RDx Module Environmental Specifications.....	16
Table 6.	Values for ATEX Conformance .....	17
Table 7.	Pad Description .....	19
Table 8.	Power Supply .....	25
Table 9.	Current Consumption .....	25
Table 10.	Current Consumption per Power Supply (VBATT / VBATT_PA).....	26
Table 11.	VGPIO Electrical Characteristics.....	27
Table 12.	BAT_RTC Electrical Characteristics.....	28
Table 13.	Electrical Characteristics of UIM1 .....	28
Table 14.	USB Pad Description.....	29
Table 15.	USB_VBUS Electrical Characteristics.....	30
Table 16.	Digital I/O Electrical Characteristics – Input/Output Voltage.....	30
Table 17.	Digital I/O Electrical Characteristics – Group 1 Input/Output Current.....	31
Table 18.	Digital I/O Electrical Characteristics – Group 2 Input/Output Current.....	31
Table 19.	Internal Resistance for Group 2 Interface (UART) on the HL6528x-2.8V.....	31
Table 20.	Digital I/O Electrical Characteristics – Group 3 Input/Output Current.....	31
Table 21.	Digital I/O Electrical Characteristics – Group 4 Input/Output Current.....	32
Table 22.	GPIO Pad Description .....	32
Table 23.	UART1 Pad Description .....	33
Table 24.	PWR_ON_N Electrical Characteristics .....	34
Table 25.	RESET_IN_N Electrical Characteristics.....	36
Table 26.	ADC Electrical Characteristics .....	36
Table 27.	Clock Interface Pad Description.....	36
Table 28.	Analog Audio Differential Interface Input.....	37
Table 29.	Analog Audio Differential Interface Output.....	38
Table 30.	Recommended Speaker Characteristics.....	38
Table 31.	Digital Audio Interface Electrical Characteristics.....	39
Table 32.	I <sup>2</sup> C Pad Description .....	40
Table 33.	SW Trace Pad Description .....	40
Table 34.	JTAG Pad Description.....	41
Table 35.	PPS Electrical Characteristics.....	41
Table 36.	EXT_LNA_GPS_EN Electrical Characteristics .....	42
Table 37.	RF Connection.....	42

---

Table 38.	RF Performance .....	42
Table 39.	Burst Indicator States .....	43
Table 40.	TX Burst Characteristics.....	43
Table 41.	GNSS Interface Specifications .....	44
Table 42.	GNSS Antenna Specifications.....	45
Table 43.	GNSS Antenna Recommendations.....	45
Table 44.	Recommended Components for a Microphone Connection .....	53
Table 45.	Recommended Components for a Single-Ended Microphone Connection .....	54
Table 46.	Speaker Details .....	54
Table 47.	Standards Conformity for the AirPrime HL6528RDx Embedded Modules.....	60
Table 48.	Life Stress Test.....	60
Table 49.	Environmental Resistance Stress Tests .....	61
Table 50.	Corrosive Resistance Stress Tests .....	61
Table 51.	Thermal Resistance Cycle Stress Tests .....	62
Table 52.	Mechanical Resistance Stress Tests .....	63
Table 53.	Handling Resistance Stress Tests .....	64
Table 54.	AirPrime HL6528RDx FCC IDs .....	65
Table 55.	AirPrime HL6528RDx IC IDs .....	67

# 1. Introduction

The HL6528RDx series of embedded modules were created to improve, expand and enhance the design of the existing HL6528x.

This document defines the high-level product features and illustrates the interfaces for the AirPrime HL6528RDx, and covers the hardware aspects of the product series, including electrical and mechanical.

Redesigned variants covered in this document are:

- HL6528RD
- HL6528RD-G
- HL6528RD-2.8V
- HL6528RD-G2.8V

The AirPrime HL6528RD and HL6528RD-G modules are 1.8V IO modules as defined in section 2 Pad Definition. 2.8V IO variants are also available, and defined throughout this document as HL6528RD-2.8V and HL6528RD-G2.8V. HL6528RDx denotes applicability to all four variants.

The AirPrime HL6528RDx belongs to the AirPrime HL Series from Essential Connectivity Module family. This is an industrial-grade quad-band GSM/GPRS Embedded Wireless Module, designed for the automotive market and any other market with similar quality and life-time support requirements. The following table enumerates the frequencies supported by the HL6528RDx module.

Table 1. Supported Frequencies

RF Band	Transmit Band (Tx)	Receive Band (Rx)	Maximum Output Power
GSM 850	824 to 849 MHz	869 to 894 MHz	2 Watts GSM and GPRS
E-GSM 900	880 to 915 MHz	925 to 960 MHz	2 Watts GSM and GPRS
DCS 1800	1710 to 1785 MHz	1805 to 1880 MHz	1-Watt GSM and GPRS
PCS 1900	1850 to 1910 MHz	1930 to 1990 MHz	1-Watt GSM and GPRS

This module supports a large variety of interfaces such as Analog and Digital Audio, as well as Dual UIM Single Standby to provide customers with the highest level of flexibility in implementing high-end solutions. In addition, both AirPrime HL6528RD-G and HL6528RD-G2.8V modules also embed a high-performance GNSS receiver.

## 1.1. Common Flexible Form Factor (CF<sup>3</sup>)

The AirPrime HL6528RDx module belongs to the Common Flexible Form Factor (CF<sup>3</sup>) family of modules. This family consists of a series of WWAN modules that share the same mechanical dimensions (same width and length with varying thicknesses) and footprint. The CF<sup>3</sup> form factor provides a unique solution to a series of problems faced commonly in the WWAN module space as it:

- Accommodates multiple radio technologies (from 2G to LTE advanced) and band groupings
- Supports bit-pipe (Essential Module Series) and value add (Smart Module Series) solutions
- Offers electrical and functional compatibility
- Provides Direct Mount as well as Socketability depending on customer needs

## 1.2. Physical Dimensions

The AirPrime HL6528RDx modules are compact, robust, fully shielded modules with the following dimensions:

- Length: 23 mm
- Width: 22 mm
- Thickness: 2.50 mm (including the label)
- Weight: 2.25g

---

*Note:* Dimensions specified above are typical values.

---

## 1.3. General Features

The table below summarizes the AirPrime HL6528RDx module features.

Table 2. AirPrime HL6528RDx Features

Feature	Description
<b>GSM Output Power</b>	<ul style="list-style-type: none"> <li>• Class 4 (2 W) for GSM 850 and E-GSM 900</li> <li>• Class 1 (1 W) for DCS 1800 and PCS 1900</li> </ul>
<b>GPRS</b>	<ul style="list-style-type: none"> <li>• Quad-band GSM 850/E-GSM 900/DCS 1800/PCS 1900</li> <li>• GPRS Multi-slot class 10</li> <li>• R99 support</li> <li>• PBCCH support</li> <li>• Coding schemes: CS1 to CS4</li> </ul>
<b>Audio Interface</b>	<ul style="list-style-type: none"> <li>• Analog and Digital interfaces</li> <li>• Supports Full Rate (FR), Enhanced Full Rate (EFR), Half Rate (HR) and Adaptive Multi Rate (AMR)</li> <li>• Noise reduction and echo cancellation</li> <li>• DTMF generation</li> </ul>
<b>UIM Interface</b>	<ul style="list-style-type: none"> <li>• Dual UIM Single Standby support</li> <li>• 1.8V/3.0V support</li> <li>• Supports UIM application tool kit with proactive UIM commands</li> </ul>
<b>Application Interface</b>	<ul style="list-style-type: none"> <li>• Full set of AT commands for GSM/GPRS including GSM 07.07 and 07.05 AT command sets</li> <li>• Comprehensive set of dedicated AT commands for M2M applications</li> </ul>
<b>SMS</b>	<ul style="list-style-type: none"> <li>• SMS class 0, 1 and 2</li> <li>• SMS MT, MO</li> <li>• SMS storage into UIM card or Flash memory</li> <li>• Concatenation of MT SMS</li> </ul>
<b>Supplementary Services</b>	<ul style="list-style-type: none"> <li>• Call Forwarding</li> <li>• Call Barring</li> <li>• Multiparty Service</li> <li>• Call Waiting</li> <li>• Call Hold</li> <li>• USSD</li> <li>• Automatic answer</li> </ul>
<b>RTC</b>	Real Time Clock (RTC) with calendar and alarm

Feature	Description
Temperature Sensor	<ul style="list-style-type: none"> <li>Temperature monitoring</li> <li>Alarms</li> </ul>
Memory	<ul style="list-style-type: none"> <li>Flash: 64 Mbit/s</li> <li>PSRAM: 32 Mbit/s</li> </ul>

## 1.4. GNSS Features

The table below summarizes the GNSS capabilities of the AirPrime HL6528RD-G and HL6528RD-G2.8V modules.

Table 3. GNSS Capabilities

Feature	Description
GPS	L1 band (CDMA 1575.42 MHz)
GLONASS	L1 Band (FDMA 1602MHz)
SBAS	WAAS, EGNOS, MSAS, GAGAN
Channels	52
Antenna	Passive or active antenna support
Assistance data	Server-generated Extended Ephemeris

## 1.5. Architecture

The figure below presents an overview of the AirPrime HL6528RDx module's internal architecture and external interfaces.

*Note: Dotted parts are only supported on the AirPrime HL6528RD-G and HL6528RD-G2.8V.*

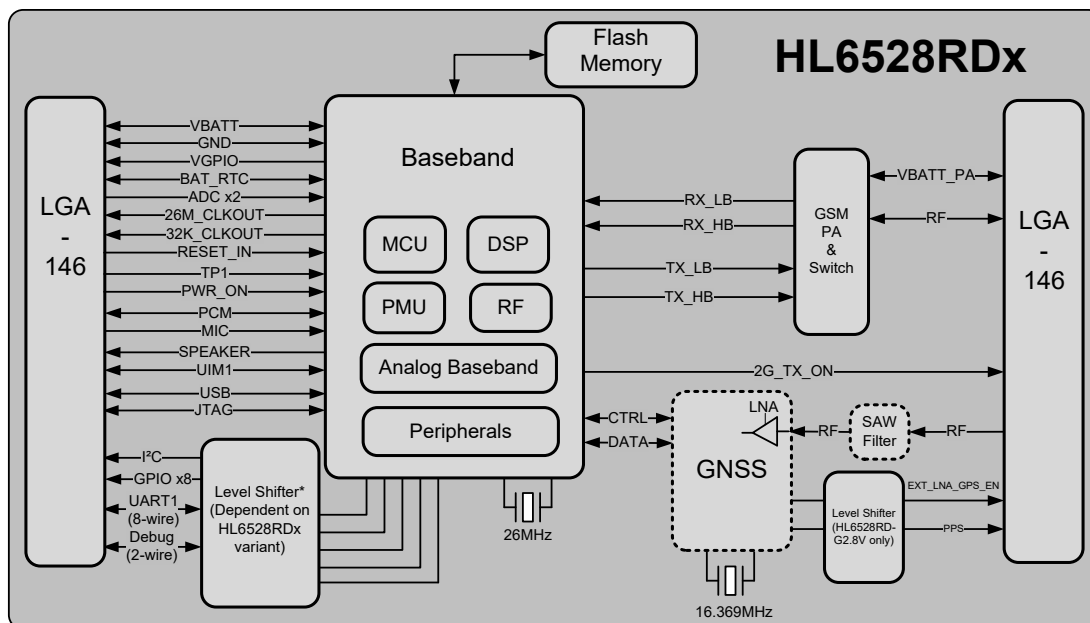

\* For more information regarding voltage values, refer to section 3.7 Electrical Information for Digital I/O

Figure 1. AirPrime HL6528RDx Architecture Overview

## 1.6. Interfaces

The AirPrime HL6528RD and HL6528RD-2.8V modules provide the following interfaces and peripheral connectivity:

- 1x – Backup Battery Interface
- 1x – 1.8V/3V UIM
- 1x – USB 1.1
- 8x – GPIOs, 3 of which have multiplexes
- 1x – 8-wire UART
- 1x – Active Low PWR\_ON\_N
- 1x – Active Low RESET\_IN\_N
- 2x – ADC
- 2x – System Clock Out
- 1x – Analog Audio Interface (Differential input/output)
- 1x – Digital Audio
- 1x – I<sup>2</sup>C
- 1x – Debug Interface
- 1x – JTAG Interface
- 1x – GSM Antenna
- 1x – 2G TX Burst Indicator

In addition to the interfaces above, the AirPrime HL6528RD-G and HL6528RD-G2.8V modules also provide the following interfaces and peripheral connectivity:

- GPS Antenna
- External LNA Enable/Disable
- Pulse Per Second

## 1.7. Connection Interface

The AirPrime HL6528RDx module is an LGA form factor device. All electrical and mechanical connections are made through the 146 pads Land Grid Array (LGA) on the bottom side PCB.

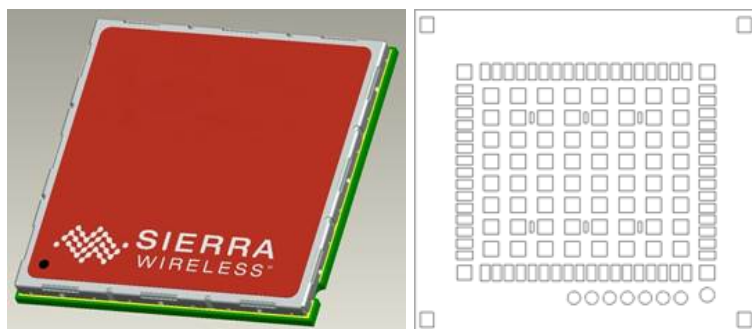

Figure 2. AirPrime HL6528RDx Module Mechanical Overview

The 146 pads have the following distribution

- 66 inner signal pads, 1x0.5mm, pitch 0.8mm
- 1 reference test point (Ground), 1.0mm diameter
- 7 test point (JTAG), 0.8mm diameter, 1.20mm pitch
- 64 inner ground pads, 1.0x1.0mm, pitch 1.825mm/1.475mm
- 4 inner corner ground pads, 1x1mm
- 4 outer corner ground pads, 1x0.9mm

## 1.8. ESD

Refer to the following table for ESD Specifications.

Table 4. ESD Specifications

Category	Connection	Specification
Operational	RF ports	IEC-61000-4-2 — Level (Electrostatic Discharge Immunity Test) ESD protection is highly recommended at the point where the antenna (main and GPS) contacts are exposed.
Non-operational	Host connector interface	Unless otherwise specified: <ul style="list-style-type: none"> <li>• JESD22-A114 ± 1500V Human Body Model</li> <li>• JESD22-A115 ± 150V Machine Model</li> <li>• JESD22-C101C ± 500V Charged Device Model</li> </ul>
Signals	SIM connector	ESD protection is highly recommended at the point where the USIM contacts are exposed, and for any other signals that would be subjected to ESD by the user.
	Other host signals	

## 1.9. Environmental and Certifications

### 1.9.1. Environmental Specifications

The environmental specification for both operating and storage conditions are defined in the table below.

Table 5. AirPrime HL6528RDx Module Environmental Specifications

Conditions	Range
Operating Class A	-30°C to +70°C
Operating Class B	-40°C to +85°C
Storage	-40°C to +90°C

Class A is defined as the operating temperature ranges that the device:

- Shall exhibit normal function during and after environmental exposure.
- Shall meet the minimum requirements of 3GPP or appropriate wireless standards.

Class B is defined as the operating temperature ranges that the device:

- Shall remain fully functional during and after environmental exposure
- Shall exhibit the ability to establish a voice, SMS or DATA call (emergency call) at all times even when one or more environmental constraint exceeds the specified tolerance.
- Unless otherwise stated, full performance should return to normal after the excessive constraint(s) have been removed.

## 1.9.2. RoHS Directive Compliance

AirPrime HL6528RDx modules are compliant with RoHS Directive 2011/65/EU, including directive 2015/863 amending annex II, which sets limits for the use of certain restricted hazardous substances. This directive states that electrical and electronic equipment put on the market does not contain lead, mercury, cadmium, hexavalent chromium, polybrominated biphenyls (PBB), polybrominated diphenyl ethers (PBDE), Bis (2-ethylhexyl) phthalate (DEHP), Butyl benzyl phthalate (BBP), Dibutyl phthalate (DBP) or Diisobutyl phthalate (DIBP) above threshold limits.

## 1.9.3. Disposing of the Product

This electronic product is subject to the EU Directive 2012/19/EU for Waste Electrical and Electronic Equipment (WEEE). As such, this product must not be disposed of at a municipal waste collection point. Please refer to local regulations for directions on how to dispose of this product in an environmentally friendly manner.



## 1.10. Conformance with ATEX 94/9/CE Directive

To evaluate the conformity of a product using the AirPrime HL6528RDx with ATEX 94/9/CE directive, the integrator must consider the following data from the AirPrime HL6528RDx.

Table 6. Values for ATEX Conformance

Variant	Sum of all Capacitors	Sum of all Inductors	Biggest Single Capacitor	Biggest Single Inductor
HL6528RD, HL6526RD-2.8V	93 $\mu$ F	0.02 $\mu$ H	22 $\mu$ F $\pm$ 20%	0.0043 $\mu$ H $\pm$ 20%
HL6528RD-G, HL6528RD-G2.8V	107 $\mu$ F	1.3 $\mu$ H	22 $\mu$ F $\pm$ 20%	1 $\mu$ H $\pm$ 20%

## 1.11. References

- [1] AirPrime HL Series Customer Process Guidelines  
Reference Number: 4114330
- [2] AirPrime HL6528RDx AT Commands Interface Guide  
Reference Number: 4117743
- [3] AirPrime HL Series Development Kit User Guide  
Reference Number: 4114877

## 2. Pad Definition

AirPrime HL6528RDx module pads are divided into 3 functional categories.

- **Core functions and associated pads** cover all the mandatory features for M2M connectivity and will be available by default across all CF<sup>3</sup> family of modules. These Core functions are always available and always at the same physical pad locations. A customer platform using only these functions and associated pads is guaranteed to be forward and/or backward compatible with the next generation of CF<sup>3</sup> modules.
- **Extension functions and associated pads** bring additional capabilities to the customer. Whenever an Extension function is available on a module, it is always at the same pad location.
- **Custom functions and associated pads** are specific to a given module, and make an opportunistic use of specific chipset functions and I/Os. Custom features should be used with caution as there is no guarantee that the custom functions available on a given module will be available on other CF<sup>3</sup> modules.

Other pads marked as “not connected” or “reserved” should not be used.

Table 7. Pad Description

Pad #	Signal Name	Function	I/O	Active Low / High	IO Voltage Domain for HL6528RD and HL6528RD-G	IO Voltage Domain for HL6528RD-2.8V and HL6528RD-G2.8V	Reset State**	Recommendation for Unused Pads	Type
1	GPIO1 / I2C1_CLK	General purpose input/output / I <sup>2</sup> C serial clock line	I/O		1.8V	2.8V	I, PU	Left Open	Extension
2	UART1_RI	UART1 Ring indicator	O		1.8V	2.8V	I, PU	Left Open	Core
3	UART1_RTS	UART1 Request to send	I	L	1.8V	2.8V	I, PU	Connect to UART1_CTS	Core
4	UART1_CTS	UART1 Clear to send	O	L	1.8V	2.8V	I, PU	Connect to UART1_RTS	Core
5	UART1_TX	UART1 Transmit data	I		1.8V	2.8V	I, PU	Mandatory connection	Core
6	UART1_RX	UART1 Receive data	O		1.8V	2.8V	O, H	Mandatory connection	Core

Pad #	Signal Name	Function	I/O	Active Low / High	IO Voltage Domain for HL6528RD and HL6528RD-G	IO Voltage Domain for HL6528RD-2.8V and HL6528RD-G2.8V	Reset State**	Recommendation for Unused Pads	Type
7	UART1_DTR	UART1 Data terminal ready	I	L	1.8V	2.8V	I, PU	Connect to UART1_DSR	Core
8	UART1_DCD	UART1 Data carrier detect	O	L	1.8V	2.8V	I, PD	Left Open	Core
9	UART1_DSR	UART1 Data set ready	O	L	1.8V	2.8V	I, PD	Connect to UART1_DTR	Core
10	GPIO2	General purpose input/output	I/O		1.8V	2.8V	O, H	Left Open	Core
11	RESET_IN_N	Input reset signal	I	L	1.8V	1.8V	O, H	Left Open (Test point recommended)	Core
12	USB_D-	USB Data Negative	I/O		3.3V	3.3V	T	Left Open	Extension
13	USB_D+	USB Data Positive	I/O		3.3V	3.3V	T	Left Open	Extension
14	NC	Not Connected							Not Connected
15	NC	Not Connected							Not Connected
16	USB_VBUS	USB VBUS	I		5V	5V	I, T		Extension
17	SPKR_N	Speaker negative output (32Ω impedance)	O		2.8V	2.8V	O, PD	Left Open	Extension
18	SPKR_P	Speaker positive output (32Ω impedance)	O		2.8V	2.8V	O, PD	Left Open	Extension
19	MIC_P	Microphone positive input	I		2.8V	2.8V	I, T	Left Open	Extension
20	MIC_N	Microphone negative input	I		2.8V	2.8V	I, T	Left Open	Extension
21	BAT_RTC	Power supply for RTC backup	I/O		2.8V	2.8V	O, H	C=10μF	Extension
22	26M_CLKOUT	26MHz System Clock Output	O		1.2V	1.2V	I, PD	Left Open	Extension
23	32K_CLKOUT	32.768kHz System Clock Output	O		2.8V	2.8V	I, PD	Left Open	Extension
24	ADC1	Analog to digital conversion	I		2.8V	2.8V	I, T	Connected to Ground	Extension
25	ADC0	Analog to digital conversion	I		2.8V	2.8V	I, T	Connected to Ground	Extension
26	UIM1_VCC	1.8V/3V UIM1 Power supply	O		1.8V/3V	1.8V/3V	N/A	Mandatory connection	Core

Pad #	Signal Name	Function	I/O	Active Low / High	IO Voltage Domain for HL6528RD and HL6528RD-G	IO Voltage Domain for HL6528RD-2.8V and HL6528RD-G2.8V	Reset State**	Recommendation for Unused Pads	Type
27	UIM1_CLK	1.8V/3V UIM1 Clock	O		1.8V/3V	1.8V/3V	I, PD	Mandatory connection	Core
28	UIM1_DATA	1.8V/3V UIM1 Data	I/O		1.8V/3V	1.8V/3V	I, PD	Mandatory connection	Core
29	UIM1_RESET	1.8V/3V UIM1 Reset	O	L	1.8V/3V	1.8V/3V	I, PD	Mandatory connection	Core
30	NC	NC (Reserved for 3G compatibility)							Not Connected
31	NC	NC (Reserved for 3G compatibility)							Not Connected
32	NC	NC (Reserved for 3G compatibility)							Not Connected
33	PCM_OUT	PCM data out	O		2.8V	2.8V	I, PD	Left Open	Extension
34	PCM_IN	PCM data in	I		2.8V	2.8V	I, PD	Left Open	Extension
35	PCM_SYNC	PCM sync out	I/O		2.8V	2.8V	I, PD	Left Open	Extension
36	PCM_CLK	PCM clock	I/O		2.8V	2.8V	I, PD	Left Open	Extension
37	GND	Ground	GND		0V	0V		Mandatory connection	Core
38	RF_GPS*	RF GPS Input	I					Mandatory connection	Extension
39	GND	Ground	GND		0V	0V		Mandatory connection	Core
40	GPIO7	General purpose input/output	I/O		1.8V	2.8V	I, PD	Left Open	Core
41	GPIO8	General purpose input/output	I/O		1.8V	2.8V	I, PD	Left Open	Core
42	PPS*	GPS Pulse Per Second	O		1.8V	2.8V	T	Left Open	Extension
43	EXT_LNA_GPS_EN*	External GPS LNA enable	O	H	1.8V	2.8V	T	Left Open	Extension
44	DEBUG_TX	Debug Transmit Data	O		1.8V	2.8V	I, PD	Left Open (Test point mandatory)	Extension
45	VGPIO	GPIO voltage output	O		1.8V	2.8V		Left Open	Core
46	GPIO6	General purpose input/output	I/O		1.8V	2.8V	I, PD	Left Open	Core

Pad #	Signal Name	Function	I/O	Active Low / High	IO Voltage Domain for HL6528RD and HL6528RD-G	IO Voltage Domain for HL6528RD-2.8V and HL6528RD-G2.8V	Reset State**	Recommendation for Unused Pads	Type
47	TP1	Test Point 1 0 - JTAG Enable Open - Normal Mode	I	L	2.8V	2.8V	I, PU	Mandatory Left Open	Extension
48	GND	Ground	GND		0V	0V		Mandatory connection	Core
49	RF_MAIN	RF GSM Input/output	I/O					Mandatory connection	Core
50	GND	Ground	GND		0V	0V		Mandatory connection	Core
51	DEBUG_RX	Debug Receive Data	I		1.8V	2.8V	I, PD	Left Open (Test point mandatory)	Extension
52	Reserved								Not Connected
53	Reserved								Not Connected
54	NC	Not connected							Not Connected
55	NC	Not connected							Not Connected
56	NC	Not connected							Not Connected
57	NC	Not connected							Not Connected
58	NC	Not connected							Not Connected
59	PWR_ON_N	Active Low Power On control signal	I	L	2.8V	2.8V	I, PU	Mandatory connection	Core
60	2G_TX_ON	2G TX burst indicator	O	H	2.8V	2.8V	T	Left Open	Extension
61	VBATT_PA	3.7V Power Amplifier Power supply	I		3.7V	3.7V		Mandatory connection	Core
62	VBATT_PA	3.7V Power Amplifier Power supply	I		3.7V	3.7V		Mandatory connection	Core
63	VBATT	3.7V Power supply	I		3.7V	3.7V		Mandatory connection	Core
64	UIM1_DET / GPIO3	UIM1 Detection / General purpose input/output	I/O	H	1.8V	2.8V	I, PD	Left Open	Core
65	GPIO4	General purpose input/output	I/O		1.8V	2.8V	I, PD	Left Open	Extension

Pad #	Signal Name	Function	I/O	Active Low / High	IO Voltage Domain for HL6528RD and HL6528RD-G	IO Voltage Domain for HL6528RD-2.8V and HL6528RD-G2.8V	Reset State**	Recommendation for Unused Pads	Type
66	GPIO5 / I2C1_DATA	General purpose input/output / I <sup>2</sup> C serial data line	I/O		1.8V	2.8V	I, PD	Left Open	Extension
67-70	GND	Ground	GND		0V	0V		Mandatory connection	Core
71-166	<i>Note: These pads are not available on the HL6528RDx module.</i>								
167 – 234	GND	GND	GND		0V	0V		Mandatory connection	Core
236	JTAG_RESET	JTAG RESET	I	L	2.8V	2.8V	O, H (1.8V)	Left Open	Extension
237	JTAG_TCK	JTAG Test Clock	I		2.8V	2.8V	I, PU	Left Open	Extension
238	JTAG_TDO	JTAG Test Data Output	O		2.8V	2.8V	I, PD	Left Open	Extension
239	JTAG_TMS	JTAG Test Mode Select	I		2.8V	2.8V	O, H	Left Open	Extension
240	JTAG_TRST	JTAG Test Reset	I	L	2.8V	2.8V	I, PD	Left Open	Extension
241	JTAG_TDI	JTAG Test Data Input	I		2.8V	2.8V	I, PD	Left Open	Extension
242	JTAG_RTCK	JTAG Returned Test Clock	O		2.8V	2.8V		Left Open	Extension

\* This pad is only available on the HL6528RD-G and H6528RD-G2.8V.

\*\* I = Input, O = Output, PU = Pull up, PD = Pull Down, H = High, T = High Impedance

## 2.1. Pad Configuration (Top View)

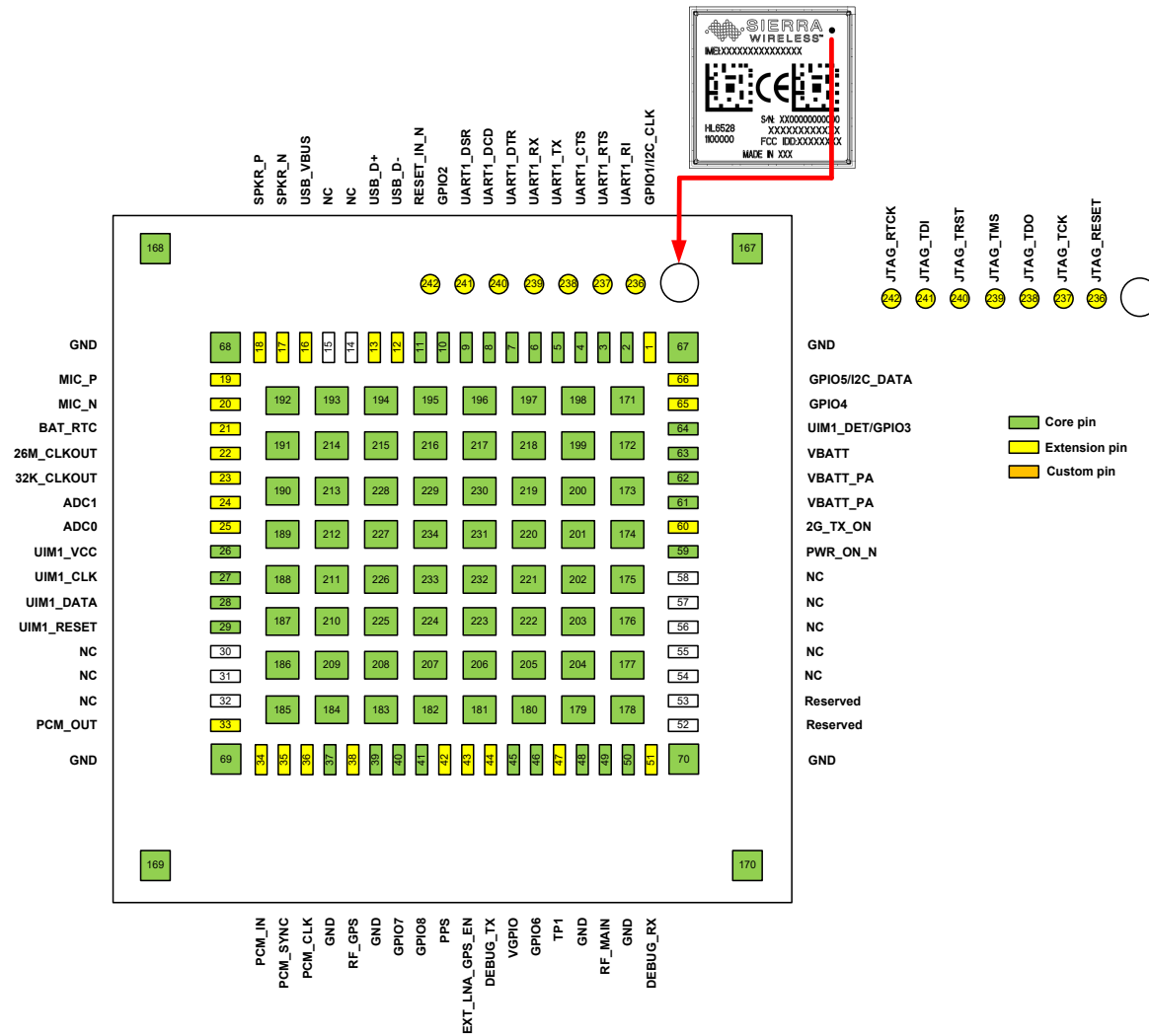

Figure 3. Pad Configuration

## 3. Detailed Interface Specifications

**Note:** If not specified, all electrical values are given for VBATT=3.7V and an operating temperature of 25°C.

If needed, the AirPrime HL6528RDx module can support two different voltages for VBATT and VBATT\_PA power inputs. However, using the same power supply for both signals is recommended.

### 3.1. Power Supply

The AirPrime HL6528RDx module is supplied through the VBATT signal with the following characteristics.

**Table 8. Power Supply**

	Minimum	Typical	Maximum
VBATT voltage (V)	3.35 <sup>1</sup>	3.7	4.3
VBATT_PA voltage (V) Full Specification	3.35 <sup>1</sup>	3.7	4.3
VBATT_PA voltage (V) Extended Range <sup>2</sup>	2.8 <sup>2</sup>	3.7	4.3

1 This value must be guaranteed during the burst.

2 No guarantee of 3GPP performances over extended range.

### 3.2. Current Consumption

The following table lists the current consumption of the AirPrime HL6528RDx module at different conditions.

**Note:** Typical values are defined for VBATT/VBATT\_PA at 3.7V and 25°C, for 50Ω impedance at all RF ports. Maximum values are provided for VSWR 3:1 with worst conditions among supported ranges of voltage and temperature.

**Table 9. Current Consumption**

Parameters		Typical	Maximum
Off mode (HL6528RD and HL6528RD-2.8V) (μA)		200	260
Off mode (HL6528RD-G and HL6528RD-G2.8V) (μA)		200	260
GSM Sleep mode (average, mA) Single UIM operation	DRX2	1.8	2.9
	DRX5	1.4	2.5
	DRX9	1.3	2.4
GSM in communication mode (average, mA)	E-GSM 900 / GSM 850 (PCL=5)	240	260
	DCS 1800 / PCS 1900 (PCL=0)	160	170
GPRS (2 TX, 3 RX) (average, mA)	E-GSM 900 / GSM 850 (PCL=5)	330	377
	DCS 1800 / PCS 1900 (PCL=0)	230	251
Peak Current consumption (peak, A)	E-GSM 900 / GSM 850	1.6	1.8
	DCS 1800 / PCS 1900	1.1	1.3

Parameters		Typical	Maximum
GNSS Acquisition <sup>1</sup> (average, mA) GSM registered on network	Max value <sup>3</sup>	46	60
	Min value <sup>4</sup>	37	46
GNSS Acquisition <sup>1</sup> (average, mA) GSM in Flight mode	Max value <sup>3</sup>	46	56
	Min value <sup>4</sup>	35	44
GNSS Navigation (1Hz) <sup>1</sup> (average, mA) GSM registered on network	Max value <sup>3</sup>	42	53
	Min value <sup>4</sup>	32	42
GNSS Navigation (1Hz) <sup>1</sup> (average, mA) GSM in Flight mode	Max value <sup>3</sup>	41	50
	Min value <sup>4</sup>	32	38
GNSS Hibernate mode <sup>2</sup> (average, mA) GSM registered on network	Max value <sup>3</sup>	15	20
	Min value <sup>4</sup>	1.5	3.3

- 1 Maximum SVs in view, signal level @-130dBm, high gain configuration.
- 2 Hot start conditions are maintained in Hibernate mode.
- 3 Baseband is running (or no sleep mode allowed) in max value condition. Refer to document [2] AirPrime HL6528RDx AT Commands Interface Guide for sleep mode description.
- 4 Baseband is in sleep mode in min value condition. Refer to document [2] AirPrime HL6528RDx AT Commands Interface Guide for sleep mode description.

**Table 10. Current Consumption per Power Supply (VBATT / VBATT\_PA)**

Parameters		Typical	Maximum	
VBATT_PA	Peak current (A) GPRS communication mode, 2TX	E-GSM 900 / GSM 850 (PCL=5)	1.5	1.8
		DCS 1800/ PCS 1900 (PCL=0)	0.9	1.0
	Peak current (A) GSM communication mode, 1TX	E-GSM 900 / GSM 850 (PCL=5)	1.5	1.8
		DCS 1800/ PCS 1900 (PCL=0)	0.9	1.0
	Average current (mA) GSM communication mode, 1TX	E-GSM 900 / GSM 850 (PCL=5)	190	210
		DCS 1800/ PCS 1900 (PCL=0)	110	130
VBATT (HL6528RD and HL6528RD-2.8V)	Peak current (A) GPRS communication mode, 2TX	E-GSM 900 / GSM 850 (PCL=5)	0.21	0.23
		DCS 1800/ PCS 1900 (PCL=0)	0.21	0.23
	Peak current (A) GSM communication mode, 1TX	E-GSM 900 / GSM 850 (PCL=5)	0.21	0.23
		DCS 1800/ PCS 1900 (PCL=0)	0.21	0.23
	Average current (mA) GSM communication mode, 1TX	E-GSM 900 / GSM 850 (PCL=5)	60	70
		DCS 1800/ PCS 1900 (PCL=0)	60	70

Parameters			Typical	Maximum
VBATT (HL6528RD-G and HL6528RD- G2.8V)	Peak current (A) GPRS communication mode, 2TX GNSS Navigation mode	E-GSM 900 / GSM 850 (PCL=5)	0.21	0.23
		DCS 1800/ PCS 1900 (PCL=0)	0.21	0.23
	Peak current (A) GSM communication mode, 1TX GNSS Navigation mode	E-GSM 900 / GSM 850 (PCL=5)	0.21	0.23
		DCS 1800/ PCS 1900 (PCL=0)	0.21	0.23
	Average current (mA) GSM communication mode, 1TX GNSS Navigation mode	E-GSM 900 / GSM 850 (PCL=5)	90	100
		DCS 1800/ PCS 1900 (PCL=0)	90	100

### 3.3. VGPIO

The VGPIO output can be used to:

- Pull-up signals such as I/Os
- Supply the digital transistors driving LEDs

The VGPIO output is available when the AirPrime HL6528RDx module is switched ON.

**Caution:** *VGPIO is only on when RESET\_IN\_N and PWR\_ON\_N are both at low level.*

Table 11. VGPIO Electrical Characteristics

Parameter	HL6528RD, HL6528RD-G			HL6528RD-2.8V, HL6528RD-G2.8V			Remarks
	Min	Typ	Max	Min	Typ	Max	
Voltage level (V)	1.70	1.80	1.90	2.7	2.80	2.95	Both active mode and sleep mode
Current capability active mode (mA)	-	-	50	-	-	50	
Current capability sleep mode (mA)	-	-	3	-	-	3	
Line regulation (mV/V)	-	-	50	-	-	50	lout = MAX
Rise Time (ns)	-	-	6	-	-	6	Test load capacitor = 30 pF

## 3.4. BAT\_RTC

The AirPrime HL6528RDx module provides an input/output to connect a Real Time Clock power supply.

This pad is used as a back-up power supply for the internal Real Time Clock. The RTC is supported when VBATT is available but a back-up power supply is needed to save date and hour when VBATT is switched off. Note that RTC tolerance is  $\pm 2.5\%$  when VBATT is not available.

If VBATT is available, the back-up battery can be charged by the internal 2.8 V power supply regulator.

Table 12. BAT\_RTC Electrical Characteristics

Parameter	Minimum	Typical	Maximum
Input voltage (V)	2.0	2.8	3.15
Input current consumption ( $\mu\text{A}$ )	-	2.5	56
Output voltage (V)	2.82	2.8	3.18
Max charging current (@VBATT=3.6V) (mA)	-	0.6	-

*Note: If unused, it is recommended to add a common 10  $\mu\text{F}$  capacitor to BAT\_RTC.*

## 3.5. UIM Interface

The AirPrime HL6528RDx has one physical UIM interface which has optional support for dual UIM application with an external UIM switch.

The UIM interface allows control of a 1.8V/3V UIM and is fully compliant with GSM 11.11 recommendations related to UIM functions.

The five signals used by the UIM interface are as follows:

- UIM1\_VCC: power supply
- UIM1\_CLK: clock
- UIM1\_DATA: I/O port
- UIM1\_RESET: reset
- UIM1\_DET: UIM detection (optional)

Table 13. Electrical Characteristics of UIM1

Parameter	Minimum	Typical	Maximum	Remarks
UIM1 Interface Voltage (V) (VCC, CLK, DATA, RESET)	2.7	3.0	3.15	The appropriate output voltage is auto detected and selected by software
	1.65	1.80	1.95	
UIM1_VCC Current (mA)	-	-	10	Max output current in sleep mode = 3 mA
UIM1_VCC Line Regulation (mV/V)	-	-	50	At Iout_Max
UIM1_VCC Power-up Setting Time ( $\mu\text{s}$ ) from power down	-	10	-	

Parameter	Minimum	Typical	Maximum	Remarks
Logic 1 of UIM1_DET (V)	2.4	-	-	For HL6528RD-2.8V and HL6528RD-G2.8V
	1.4	-	-	For HL6528RD and HL6528RD-G
Logic 0 of UIM1_DET (V)	-	-	0.4	For HL6528RD-2.8V and HL6528RD-G2.8V
	-	-	0.4	For HL6528RD and HL6528RD-G

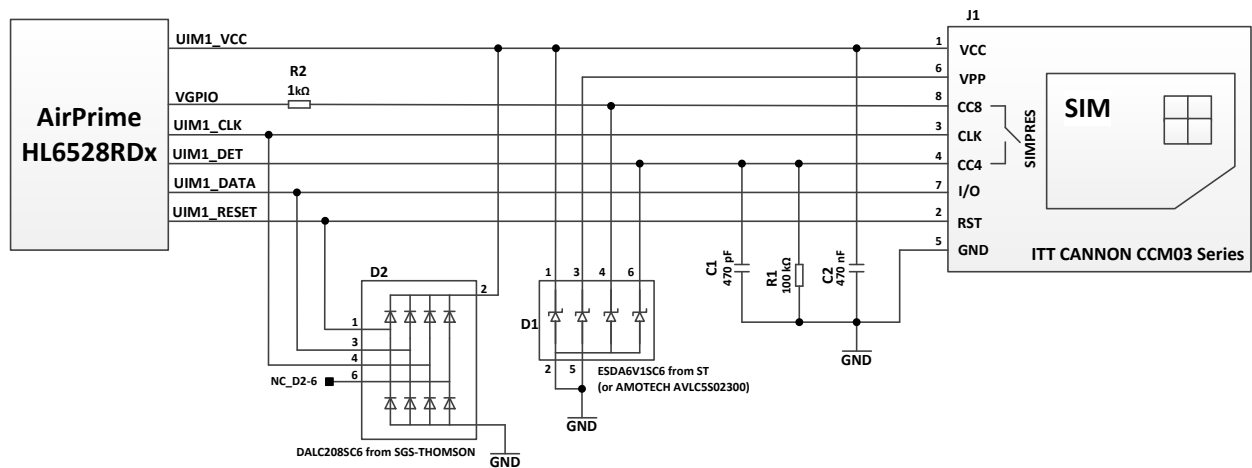

Figure 4. UIM Implementation Example

### 3.5.1. UIM1\_DET

UIM1\_DET is used to detect and notify the application about the insertion and removal of a UIM device in the UIM socket connected to the UIM interface. When a UIM is inserted, the state of UIM1\_DET transitions from logic 0 to logic 1. Inversely, when a UIM is removed, the state of UIM1\_DET transitions from logic 1 to logic 0.

The GPIO used for UIM1\_DET is GPIO3.

## 3.6. USB Interface

The AirPrime HL6528RDx has one USB interface.

USB\_VBUS is used for USB connection detection purposes. For details, refer to document [2] AirPrime HL6528RDx AT Commands Interface Guide.

Table 14. USB Pad Description

Pad #	Signal Name	I/O	Function
12	USB_D-	I/O	USB data negative
13	USB_D+	I/O	USB data position
16	USB_VBUS	I	USB VBUS

Table 15. USB\_VBUS Electrical Characteristics

Parameter	Minimum	Typical	Maximum	Unit
Input voltage	4.75	5.0	5.25	V
Input current consumption	-	1	-	mA

### 3.7. Electrical Information for Digital I/O

The AirPrime HL6528RDx supports four groups of digital interfaces with varying current drain limits.

Table 16 Digital I/O Electrical Characteristics – Input/Output Voltage provides the input and output voltage values of the digital interfaces, while the succeeding tables provides the input and output current per digital IO group. Digital IO groups are as follows:

- Group 1:
  - GPIO2
  - GPIO6
  - PPS
  - EXT\_LNA\_EN
- Group 2:
  - UART1
- Group 3:
  - GPIO3
  - GPIO4
  - GPIO7
  - GPIO8
  - I<sup>2</sup>C
- Group 4:
  - PCM
  - DEBUG\_TX

Table 16. Digital I/O Electrical Characteristics – Input/Output Voltage

Parameter	HL6528RD, HL6528RD-G			HL6528RD-2.8V, HL6528RD-G2.8V		
	Minimum	Typical	Maximum	Minimum	Typical	Maximum
Input Voltage-High (V)	1.4		2.1	2.1		3.1
Input Voltage-Low (V)			0.4			0.7
Output Voltage-High (V)	1.3		2.1	2.4		3.1
Output Voltage-Low (V)			0.4			0.4

Table 17. Digital I/O Electrical Characteristics – Group 1 Input/Output Current

Parameter	HL6528RD, HL6528RD-G			HL6528RD-2.8V, HL6528RD-G2.8V			Notes
	Min	Typ	Max	Min	Typ	Max	
Input Current-High ( $\mu$ A)	-22.5		12.5	-2			Current consumption
Input Current-Low ( $\mu$ A)	-82.5		-6.1			2	Current consumption
DC Output Current-High (mA)			16			0.02	
DC Output Current-Low (mA)	-16			-1			

Table 18. Digital I/O Electrical Characteristics – Group 2 Input/Output Current

Parameter	HL6528RD, HL6528RD-G			HL6528RD-2.8V, HL6528RD-G2.8V			Notes
	Min	Typ	Max	Min	Typ	Max	
Input Current-High ( $\mu$ A)			5	-22.5		12.5	Current consumption
Input Current-Low ( $\mu$ A)	-5			-82.5		-6.1	Current consumption
DC Output Current-High (mA)			1.5			16	
DC Output Current-Low (mA)	-1.5			-16			

Table 19. Internal Resistance for Group 2 Interface (UART) on the HL6528x-2.8V

Pin	Type	Operating State Value	Reset State Value
UART1_RX	Pull up	10 k $\Omega$ - 100 k $\Omega$	10 k $\Omega$ - 100 k $\Omega$
UART1_TX	Pull up	40 k $\Omega$ - 190 k $\Omega$	40 k $\Omega$ - 190 k $\Omega$
UART1_CTS	Pull up	15 k $\Omega$ - 55 k $\Omega$	15 k $\Omega$ - 55 k $\Omega$
UART1_RTS	Pull up	15 k $\Omega$ - 55 k $\Omega$	15 k $\Omega$ - 55 k $\Omega$
UART1_RI	Pull up	15 k $\Omega$ - 55 k $\Omega$	15 k $\Omega$ - 55 k $\Omega$
UART1_DTR	Pull up	15 k $\Omega$ - 55 k $\Omega$	15 k $\Omega$ - 55 k $\Omega$
UART1_DSR	Pull down	15 k $\Omega$ - 55 k $\Omega$	15 k $\Omega$ - 55 k $\Omega$
UART1_DCD	Pull down	15 k $\Omega$ - 55 k $\Omega$	15 k $\Omega$ - 55 k $\Omega$

Note: For the HL6528RD and HL6528RD-G, UART pins are high impedance input/output.

Table 20. Digital I/O Electrical Characteristics – Group 3 Input/Output Current

Parameter	HL6528RD, HL6528RD-G			HL6528RD-2.8V, HL6528RD-G2.8V			Notes
	Min	Typ	Max	Min	Typ	Max	
Input Current-High ( $\mu$ A)	-2			-22.5		12.5	Current consumption
Input Current-Low ( $\mu$ A)			2	-82.5		-6.1	Current consumption
DC Output Current-High (mA)			0.02			16	
DC Output Current-Low (mA)	-1			-16			

Table 21. Digital I/O Electrical Characteristics – Group 4 Input/Output Current

Parameter	HL6528RD, HL6528RD-G			HL6528RD-2.8V, HL6528RD-G2.8V			Notes
	Min	Typ	Max	Min	Typ	Max	
Input Current-High ( $\mu$ A)	-22.5		12.5	-22.5		12.5	Current consumption
Input Current-Low ( $\mu$ A)	-82.5		-6.1	-82.5		-6.1	Current consumption
DC Output Current-High (mA)			16			16	
DC Output Current-Low (mA)	-16			-16			

*Note:* The PCM interface only supports 2.8V even with 1.8V configuration.

## 3.8. General Purpose Input/Output (GPIO)

The AirPrime HL6528RDx provides 8 GPIOs, 3 of which have multiplexes.

Table 22. GPIO Pad Description

Pad #	Signal Name	Multiplex	I/O	Power Supply Domain	
				HL6528RD, HL6528RD-G	HL6528RD-2.8V, HL6528RD-G2.8V
1	GPIO1	I2C1_CLK1	I/O	1.8V	2.8V
10	GPIO2		I/O	1.8V	2.8V
40	GPIO7		I/O	1.8V	2.8V
41	GPIO8		I/O	1.8V	2.8V
46	GPIO6		I/O	1.8V	2.8V
64	GPIO3	UIM1_DET	I/O	1.8V	2.8V
65	GPIO4		I/O	1.8V	2.8V
66	GPIO5	I2C1_DATA	I/O	1.8V	2.8V

*Note:* The pull low resistance for GPI must be < 2.2 k $\Omega$ .

## 3.9. Main Serial Link (UART1)

The main serial link (UART1) is used for communication between the AirPrime HL6528RDx module and a PC or host processor. It consists of a flexible 8-wire serial interface that complies with RS-232 interface.

The supported baud rates of the UART1 are 1200, 2400, 4800, 9600, 19200, 38400, 57600 and 115200 bit/s, with autobauding and up to 1Mbit/s at maximum baud rate.

The signals used by UART1 are as follows:

- TX data (UART1\_TX)
- RX data (UART1\_RX)
- Request To Send (UART1\_RTS)
- Clear To Send (UART1\_CTS)
- Data Terminal Ready (UART1\_DTR)

- Data Set Ready (UART1\_DSR)
- Data Carrier Detect (UART1\_DCD)
- Ring Indicator (UART1\_RI)

**Note:** The capacitive load at UART1\_CTS and UART1\_RX must be lower than 45pF on the HL6528RD and HL6528RD-G (1.8V configuration).

A UART transceiver or uni-directional level shifter is needed for connection to the host when the interface level is not compatible with the HL6528RDx.

UART1 pad description is summarized below.

Table 23. UART1 Pad Description

Pad #	Signal Name*	I/O*	Description
2	UART1_RI	O	Signal incoming calls (voice and data), SMS, etc.
3	UART1_RTS	I	Wakes the module up when KSLEEP=1 is used
4	UART1_CTS	O	AirPrime HL6528RDx is ready to receive AT commands
5	UART1_TX	I	Transmit data
6	UART1_RX	O	Receive data
7	UART1_DTR	I (active low)	Prevents the AirPrime HL6528RDx from entering sleep mode, switches between data mode and command mode, and wakes the module up.
8	UART1_DCD	O	Signal data connection in progress
9	UART1_DSR	O	Signal UART interface is ON

\* From module side

### 3.9.1. 8-wire Application

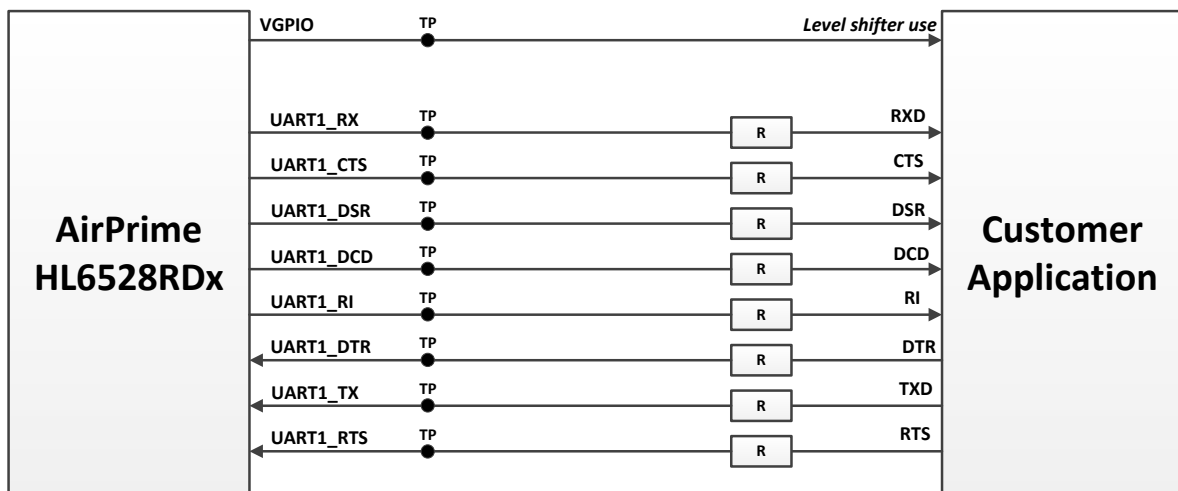

Figure 5. 8-wire UART Application Example

### 3.9.2. 4-wire Application

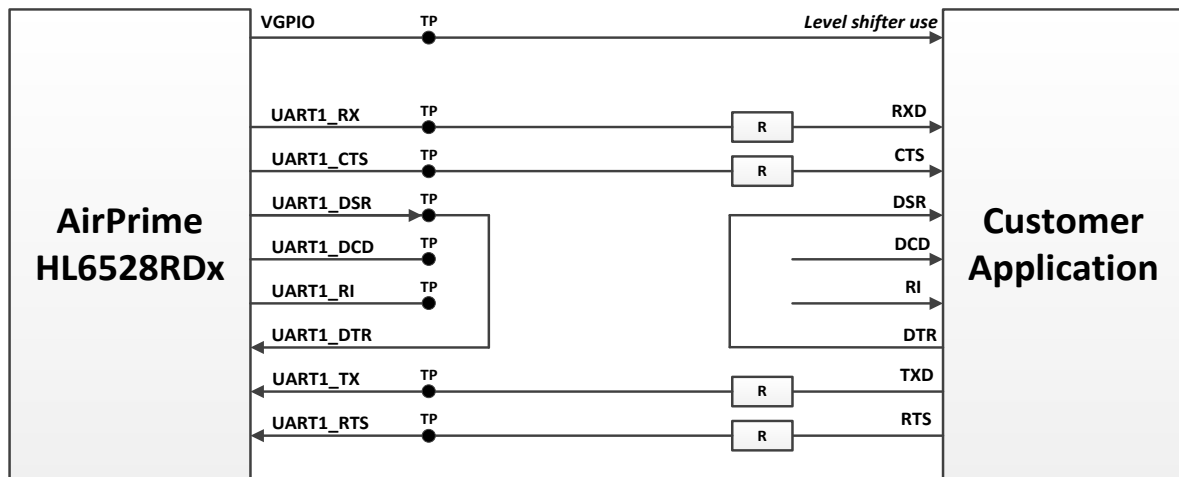

Figure 6. 4-wire UART Application Example

### 3.9.3. 2-wire Application

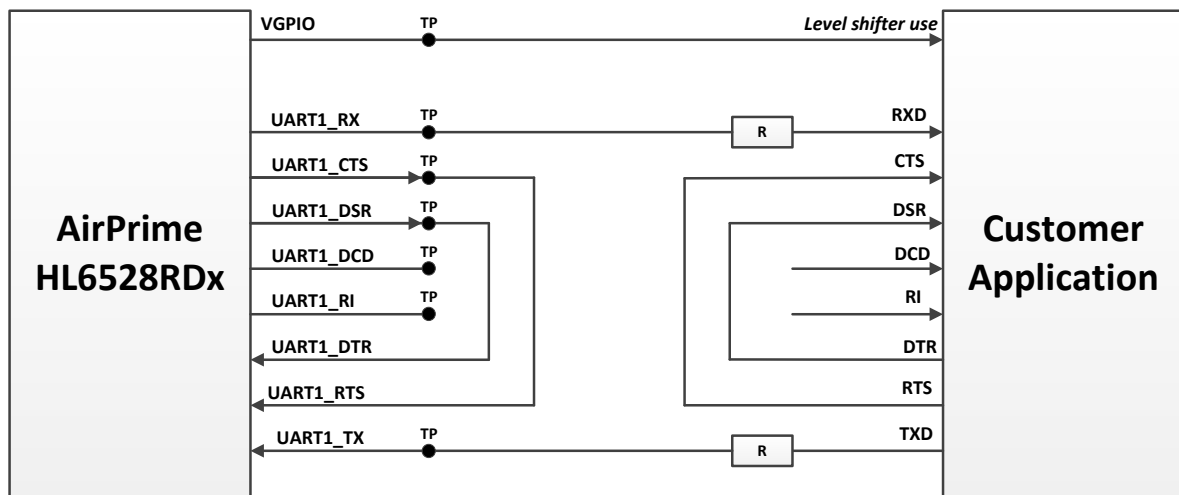

Figure 7. 2-wire UART Application Example

## 3.10. Power On Signal (PWR\_ON\_N)

A low-level signal should be provided to switch the AirPrime HL6528RDx module ON.

It is internally connected to the permanent 3.0V supply regulator inside the HL6528RDx via a pull-up resistor. Once VBATT is supplied to the HL6528RDx module, this 3.0V supply regulator will be enabled and so PWR\_ON\_N signal is by default at high level.

The PWR\_ON\_N signal's characteristics are listed in the table below.

Table 24. PWR\_ON\_N Electrical Characteristics

Parameter	Minimum	Typical	Maximum
Input Voltage-Low (V)	0	-	0.4

Parameter	Minimum	Typical	Maximum
Input Voltage-High (V)	2.4	-	3.15
Power-up period (ms) from PWR_ON_N falling edge	2000	-	-

**Note:** As PWR\_ON\_N is internally pulled up (typically by 100kΩ), a simple open collector or open drain transistor must be used for ignition. For convenience, PWR\_ON\_N can be connected to GND to automatically switch the module on when power is supplied.

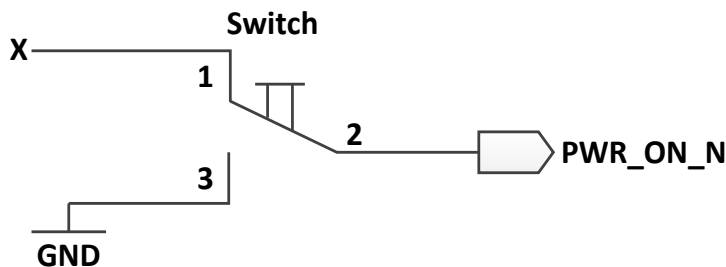

Figure 8. PWR\_ON\_N Connection Example with Switch

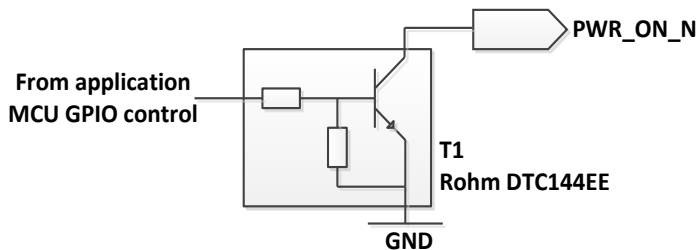

Figure 9. PWR\_ON\_N Connection Example with an Open Collector Transistor

VGPIO is an output from the module that can be used to check if the module is active.

- When VGPIO = 0V the module is OFF.
- When VGPIO = 2.8V or 1.8V the module is ON (it can be in Idle, Communication or Sleep mode)

**Caution:** VGPIO is always on when PWR\_ON\_N is at low level even during module reset.

**Note:** PWR\_ON\_N cannot be used to power the module off. The module is powered off with AT command `AT+PSCPOE`, and the PWR\_ON\_N signal will be internally pulled up to high level after.

### 3.11. Reset Signal (RESET\_IN\_N)

To reset the module, the RESET\_IN\_N pad must be tied low for at least 10ms (with PWR\_ON\_N at low level). This action will immediately restart the AirPrime HL6528RDx module. It is therefore not necessary to perform a new ignition sequence (PWR\_ON\_N) afterwards.

As RESET\_IN\_N is internally pulled up (typically by 100kΩ), a simple open collector or open drain transistor can be used to control it.

The RESET\_IN\_N signal will reset the registers of the CPU and reset the RAM memory as well.

**Note:** As RESET\_IN\_N is referenced to the 1.8V domain (internally pulled up to the module) it is impossible to enable a reset before the module is on or to try to use the RESET\_IN\_N as a way to power on the module.

**Caution:** *The module will be off if PWR\_ON\_N is high and RESET\_IN\_N is tied to low.*

**Table 25. RESET\_IN\_N Electrical Characteristics**

Parameter	Minimum	Typical	Maximum
Input Voltage-Low (V)	-0.2	-	0.4
Input Voltage-High (V)	1.4	-	2.2
Power up Period (ms) from RESET_IN_N falling edge	38	-	-

## 3.12. ADC

Two Analog to Digital Converter inputs, ADC0 and ADC1, are provided by the AirPrime HL6528RDx module. These converters are 10-bit resolution ADCs ranging from 0 to 2.8 V.

Typically, the ADCx input can be used to monitor external temperature. This is very useful for monitoring the application temperature and can be used as an indicator to safely power OFF the application in case of overheating (for Li-Ion batteries).

Both ADCs have the characteristics listed in the table below.

**Table 26. ADC Electrical Characteristics**

Parameter	Minimum	Typical	Maximum	Remarks
ADC Resolution (bits)	-	10	-	
Input Voltage Range (V)	0	-	2.8	General purpose input
Update rate per channel (kHz)	-	-	100	
Differential Nonlinearity (bits)	-1	-	+1	
Integral Nonlinearity (bits)	-1	-	+1	LSB
Offset Error (mV)	-10	-	+10	
Gain Error (mV/LSB)	-	1	-	
Input Resistance (MΩ)	-	1	-	
Input Capacitance (pF)	-	-	4	

## 3.13. Clock Interface

The AirPrime HL6528RDx supports two digital clock interfaces.

**Table 27. Clock Interface Pad Description**

Pad #	Signal Name	I/O	I/O Type	Description
22	26M_CLKOUT	O	1.2V	26MHz System Clock Output
23	32K_CLKOUT	O	2.8V	32.768kHz System Clock Output

## 3.14. Analog Audio Interfaces

The AirPrime HL6528RDx module supports one differential microphone input and one differential speaker output. It also includes a noise suppression and echo cancellation feature for enhanced voice call quality.

### 3.14.1. Analog Audio Input

The microphone input can either have a single-ended or a differential connection. However, performance with common mode noise and TDMA noise varies depending on the connection mode and PCB layout.

When connecting a microphone to the AirPrime HL6528RDx module, ensure to have a very good ground plane, very good filtering as well as shielding to avoid any disturbance on the audio path.

The gain of the microphone input can be tuned using AT commands.

The AirPrime HL6528RDx module microphone pads already include suitable biasing for an electret microphone. The electret microphone can then be connected directly on the inputs for easy connection.

AC coupling is also already embedded in the HL6528RDx embedded module.

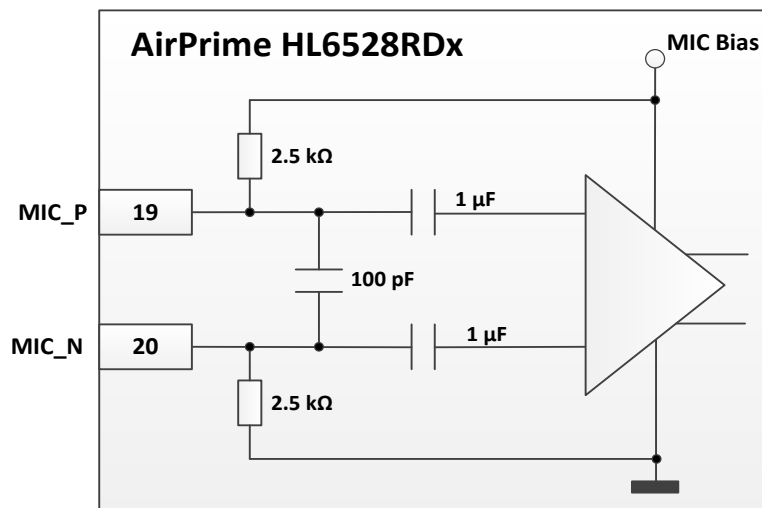

Figure 10. MIC Input Diagram

Table 28. Analog Audio Differential Interface Input

Parameter	Minimum	Typical	Maximum	Test Conditions
MIC_P DC Biasing (V)		2.2		Through internal 2.5kΩ
MIC_N DC Biasing (V)		0		Through internal 2.5kΩ
Maximum input range (V <sub>rms</sub> )		0.74		Gain = 0dB
Nominal reference level (mV <sub>rms</sub> )		16		Gain = + 34dB
Input Micro amplifier gain (dB)	-6		+ 50	

**Note:** It is recommended to add ESD protection to the microphone when it is exposed to the external environment. The ESD protection should be connected between the audio lines and a good ground, and placed as close to the microphone as possible.

## 3.14.2. Analog Audio Output

Table 29. Analog Audio Differential Interface Output

Parameter	Minimum	Typical	Maximum	Test Conditions
Maximum output range (Vrms)		1.75		Load=32Ω, THD=1%
Load resistance (Ω)		32		
Output amplifier gain (dB)	-28	-	8	

*Note:* It is recommended to add ESD protection to the speaker when it is exposed to the external environment. The ESD protection should be connected between the audio lines and a good ground, and placed as close to the speaker as possible.

It's important to select an appropriate speaker. The following table enumerates the recommended speaker characteristics.

Table 30. Recommended Speaker Characteristics

Characteristic	Value
Input power: rated / max	0.1W (Rate)
Audio chain impedance	32Ω ± 10% at 1V 1KHz
Frequency Range	300 Hz ~ 4.0 KHz
Sensitivity (S.P.L)	>105 dB at 1KHz with IEC318 coupler
Distortion	5% max at 1K Hz, nominal input power

## 3.15. PCM

The Digital Audio Interface (PCM) allows connectivity with standard audio peripherals. It can be used, for example, to connect an external audio codec.

The signals used by the Digital Audio Interface are as follows:

- PCM\_SYNC: The frame synchronization signal delivers an 8 kHz frequency pulse that synchronizes the frame “data in” and the frame “data out”.
- PCM\_CLK: The frame bit clock signal controls data transfer with the audio peripheral.
- PCM\_OUT: The frame “data out” relies on the selected configuration mode.
- PCM\_IN: The frame “data in” relies on the selected configuration mode.

The PCM interface is a high speed full duplex interface that can be used to send and receive digital audio data to external audio ICs. The digital audio interface also features the following:

- PCM master mode
- 16 bits data word length
- MSB first
- Rising sampling clock edge
- PCM Clock/Sync source: 256KHz, 512KHz, 102KHz, and 2048kHz
- Short or long PCM synchronization format (short PCM sync format by default)
- Zero Padding extension
- The programmability of this interface allows addressing a large range of audio peripheral

*Note: The PCM bit clock rate **must** be set to 1MHz in order to accommodate the 8kS/s source/sink mechanism on the DSP side, as well as the 125µs frame length.*

Refer to the following table for the electrical characteristics of the digital audio interface.

**Table 31. Digital Audio Interface Electrical Characteristics**

Signal	Description	Minimum	Typical	Maximum
Tsync_low + Tsync_high	PCM-SYNC period (µs)		125	
Tsync_low	PCM-SYNC low time (µs)		124	
Tsync_high	PCM-SYNC high time (µs)		1	
TSYNC-CLK	PCM-SYNC to PCM-CLK time (ns)		651	
TCLK-cycle	PCM-CLK period (ns)		1302	
TIN-setup	PCM-IN setup time (ns)	50		
TIN-hold	PCM-IN hold time (ns)	50		
TOUT-delay	PCM-OUT delay time (ns)			20
TSYNC-delay	PCM-SYNC output delay (ns)	-11		9

The following figure shows the PCM timing waveform.

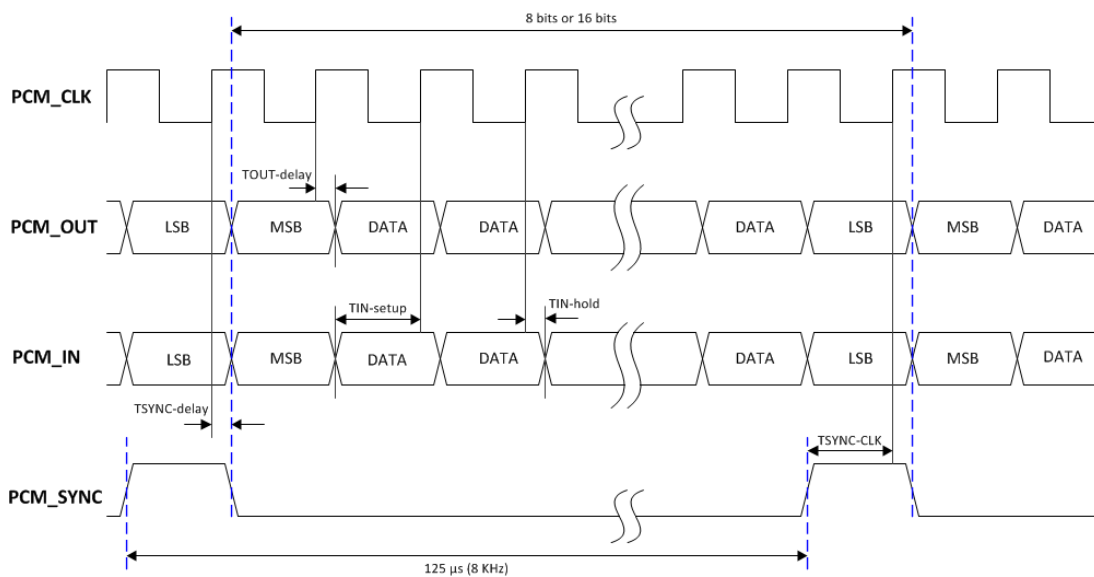

Figure 11. PCM Timing Waveform

## 3.16. I<sup>2</sup>C Interface

NMEA frames can be output from the UART or through a dedicated serial port (I<sup>2</sup>C).

Table 32. I<sup>2</sup>C Pad Description

Pad #	Name	Function
1	I2C1_CLK	I <sup>2</sup> C Serial Clock Line
66	I2C1_DATA	I <sup>2</sup> C Serial Data Line

*Note:* I<sup>2</sup>C pads are multiplexed with GPIO features and are internally pulled up to VGPI0 with 4.7kΩ.

The main characteristics of the I<sup>2</sup>C interface are as follows:

- Master mode (I2C1\_CLK is an output of the AirPrime HL6528RDx module)
- I<sup>2</sup>C clock is set at 400KHz

As the HL6528RDx's I<sup>2</sup>C interface works in master mode only, devices connected to the I<sup>2</sup>C bus shall be slave devices, and for the HL6528RDx module to communicate with slave devices, the slave device's 7-bit address should be loaded inside the HL6528RDx module before activating the GPS NMEA output. For more information on managing slave devices, refer to document [2] AirPrime HL6528RDx AT Commands Interface Guide.

## 3.17. Debug Interfaces

The AirPrime HL6528RDx module provides two interfaces for a powerful debug system.

### 3.17.1. Debug Port

The AirPrime HL6528RDx provides a 2-wire debug port interface, providing real-time instruction and data trace of the modem core.

Table 33. SW Trace Pad Description

Pad #	Signal Name*	I/O*	Function
44	DEBUG_TX	O	Debug transmit data
51	DEBUG_RX	I	Debug receive data

\* According to module view.

### 3.17.2. JTAG

*Note: This interface is reserved for Sierra Wireless' internal debug use (for customer support).*

The JTAG interface provides debug access to the core of the AirPrime HL6528RDx module. These JTAG signals are accessible through solderable Test Points.

Table 34. JTAG Pad Description

Pad #	Name	Function
47	TP1	Test Point 1
52	Reserved	JTAG configuration
53	Reserved	JTAG configuration
236	JTAG_RESET	JTAG RESET
237	JTAG_TCK	JTAG Test Clock
238	JTAG_TDO	JTAG Test Data Output
239	JTAG_TMS	JTAG Test Mode Select
240	JTAG_TRST	JTAG Test Reset
241	JTAG_TDI	JTAG Test Data Input
242	JTAG_RTCK	JTAG Returned Test Clock

*Note: It's recommended to provide access through Test Points to this interface (for failure analysis and debugging). All signals listed in the table above should be outputs on the customer board to allow JTAG debugging.*

### 3.18. PPS (HL6528RD-G and HL6528RD-G2.8V only)

The PPS signal is an output pulse related to GPS receiver time.

Table 35. PPS Electrical Characteristics

Parameter		Minimum	Typical	Maximum	Conditions
Voltage Level (V)	HL6528RD-G	1.70	1.80	1.90	
	HL6528RD-G2.8V	2.7	2.8	2.95	
Frequency (Hz)			1		
Pulse width (ms)			250		
Synchronization to GPS time ( $\mu$ s)				1	

*Note: This output is available only when GNSS is in navigation mode.*

## 3.19. EXT\_LNA\_GPS\_EN (HL6528RD-G and HL6528RD-G2.8V only)

EXT\_LNA\_GPS\_EN ON indicates whether the GNSS receiver is active and can be used to enable an external LNA (or active antenna).

Table 36. EXT\_LNA\_GPS\_EN Electrical Characteristics

Parameter		Minimum	Typical	Maximum	Conditions
Output Voltage Level (V)	HL6528RD-G	1.70	1.80	1.90	
	HL6528RD-G2.8V	2.7	2.8	2.95	
Output Current (mA)	HL6528RD-G	0	-	1.5	
	HL6528RD-G2.8V	0	-	2	

## 3.20. RF Interface

The GSM RF interface of the AirPrime HL6528RDx module allows the transmission of RF signals. This interface has a 50Ω nominal impedance.

Contact Sierra Wireless technical support for assistance in integrating the AirPrime HL6528RDx on applications with embedded antennas.

### 3.20.1. RF Connection

A short 50Ω (with maximum VSWR 1.1:1, and 0.5dB loss) RF track is recommended to connect to standard RF connectors such as SMA, UFL, etc. for antenna connection.

Table 37. RF Connection

RF Signal	Impedance	VSWR Rx (max)	VSWR Tx (max)
RF_MAIN	50Ω	3:1	3:1

### 3.20.2. RF Performances

RF performances are compliant with the ETSI recommendation GSM 05.05.

Table 38. RF Performance

Frequency Band	Typical Sensitivity (dBm)
GSM 850	-109
E-GSM 900	-109
DCS 1800	-108
PCS 1900	-108

### 3.20.3. TX Burst Indicator (2G\_TX\_ON)

The AirPrime HL6528RDx module provides a signal, 2G\_TX\_ON, for TX burst indication. 2G\_TX\_ON is a 2.8V signal and its status depends on the module transmitter state.

Refer to the following table for the status of the 2G\_TX\_ON signal depending on the embedded module's state.

Table 39. Burst Indicator States

Embedded Module State	2G_TX_ON
During TX burst	High
No TX	Low

During TX burst, there is a higher current drain from the VBATT\_PA power supply which causes a voltage drop. This voltage drop from VBATT\_PA is a good indication of a high current drain situation during TX burst.

The blinking frequency is about 217Hz.

The output logic high duration,  $T_{duration}$ , depends on the number of TX slots and is computed as follows:

$$T_{duration} = T_{advance} + (0.577ms \times \text{number of TX slots}) + T_{delay}$$

Table 40. TX Burst Characteristics

Parameter	Minimum	Typical	Maximum
High level output voltage (V)	2.7	2.85	3
Low level output voltage	0		0.1
Tadvance (µs)	30	240	
Tdelay (µs)	0	30	

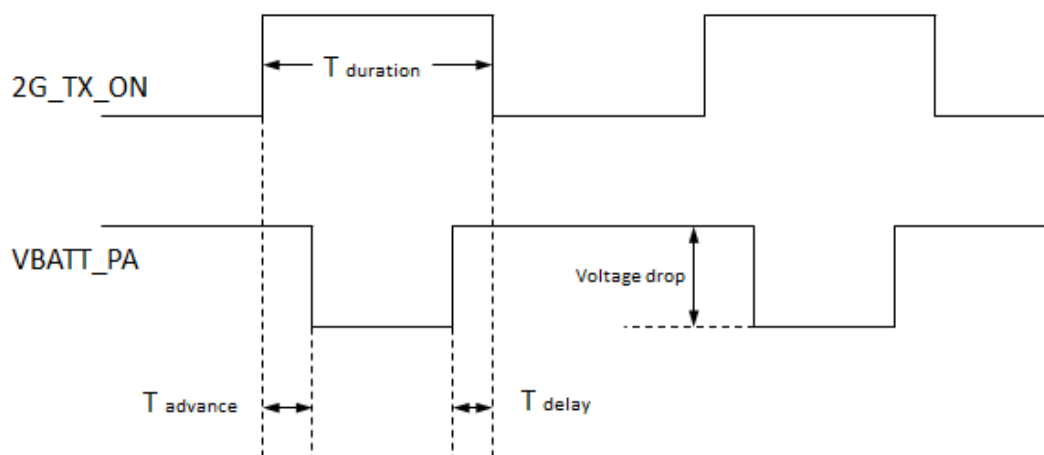

Figure 12. 2G\_TX\_ON State during TX Burst

## 3.21. GNSS Interface

The AirPrime HL6528RD-G and HL6528RD-G2.8V modules embed an integrated and high-sensitivity Global Navigation Satellite System (GNSS) solution.

Based on SiRFstarV™ from CSR, the AirPrime HL6528RD-G and HL6528RD-G2.8V modules combine GPS and GLONASS reception to improve navigation capabilities and position accuracy in obstructed view environments such as urban canyons. GNSS performances are improved by CW jammer and interference mitigation system and automated hardware blanking capabilities.

In addition, it supports Downloaded Extended Ephemeris Assisted-GNSS, for enhanced time to acquire or reacquire a fix.

The operation of GNSS is offloaded to a GNSS standalone solution to guarantee the availability of modem resources for best performance.

The GNSS implementation supports GPS L1 signal ( $1575.42 \pm 20$  MHz) and GLONASS L1 FDMA signals for frequency -7 to 6 (1597.5 – 1605.8 MHz), with 50Ω connection on the RF\_GPS pad.

### 3.21.1. GNSS Performances

Table 41. GNSS Interface Specifications

Test	Parameters	Typical Value	
Sensitivity	GPS Autonomous Acquisition (dBm); Cold and Warm start conditions	-146	
	GPS Autonomous Acquisition (dBm); Hot start conditions	-159	
	GPS Navigation (dBm)	-161	
	GLONASS Navigation (dBm)	-158	
	GNSS Navigation (dBm)	-161	
	GPS Tracking (dBm)	-165	
	GLONASS Tracking (dBm)	-165	
Autonomous Cold Start	Time To First Fix (s)	50%	20.8
		95%	34.8
	2D Position Error (m)	50%	2.9
		95%	8.9
Autonomous Warm Start	Time To First Fix (s)	50%	11.9
		95%	34.7
	2D Position Error (m)	50%	4.5
		95%	10
Autonomous Hot Start	Time To First Fix (s)	50%	1.9
		95%	1.9
	2D Position Error (m)	50%	4.5
		95%	9.5

*Note:* Values in the table above are based on static conditions, RF GNSS level @-130dBm. Cold start does not include internal GNSS firmware download on first GNSS start.

### 3.21.2. GNSS Antenna Interface

Specifications for the GNSS antenna interface are defined in the table below.

Table 42. GNSS Antenna Specifications

Characteristics		GNSS
Frequency (MHz)	GPS L1	1575.42±20
	GLONASS L1 FDMA	1597.5-1605.8
RF Impedance ( $\Omega$ )		50
VSWR max		2:1

The minimum isolation between GNSS and GSM antennas should be 20 dB.

### 3.21.3. GNSS Antenna Recommendations

Both passive and active antennas are supported by the AirPrime HL6528RD-G and HL6528RD-G2.8V modules.

The table below describes the expected performance function as input signal power.

Table 43. GNSS Antenna Recommendations

GNSS Signal Level Description	Input Signal Power (dBm)	Expected Performances
Absolute maximum	-110	Maximum to input level
Good	>-134	Best performance in TTFF and position accuracy
Acceptable	>-147	Minimum input level to allow initial acquisition without aiding
Poor	<-147	No signal acquisition without aiding
Minimum usable signal	-161	Below this level, no fix with reasonable error
Minimum tracking level	-165	Minimum level to lock the signal for fast recovery when the signal returns to the minimum usable level

For passive antennas, the internal LNA should be set to high gain mode. When configured in high gain mode, the noise figure of the HL6528RD-Gx's GNSS input is 3 dB.

For active antennas, the configuration of the internal LNA gain is dependent on external RF chain implementation, especially for the external net gain (i.e. gain from the antenna input to the module input including LNA gain minus cable losses).

The internal LNA gain should be set to low gain if the external net gain is higher than 8 dB. When configured in low gain mode, the noise figure of the HL6528RD-Gx's GNSS input is 7 dB.

The external net gain should never exceed 22 dB.

If the external net gain is lower than 8 dB, it is recommended that the internal LNA gain be set to high gain mode.

These limits have been determined for active antennas with noise figures lower than 3 dB.

## 4. Mechanical Drawings

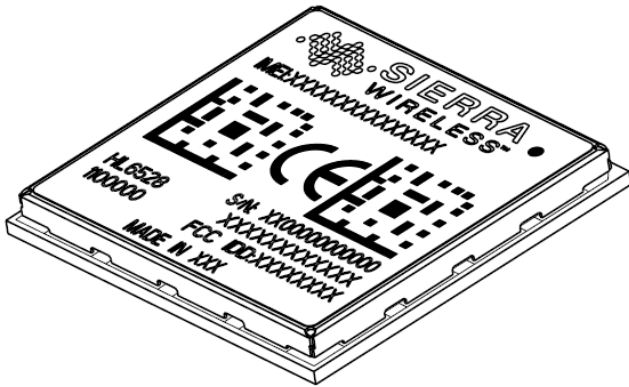

Figure 13. AirPrime HL6528RDx (angular view)

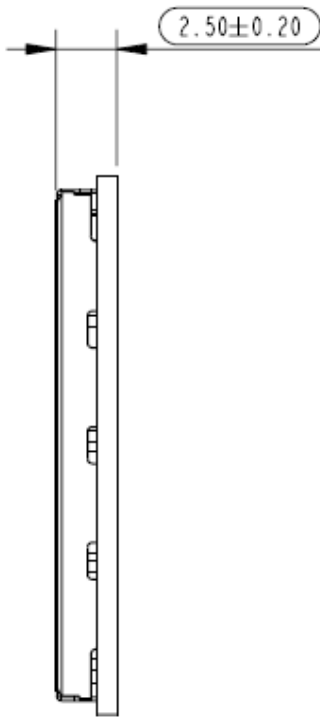
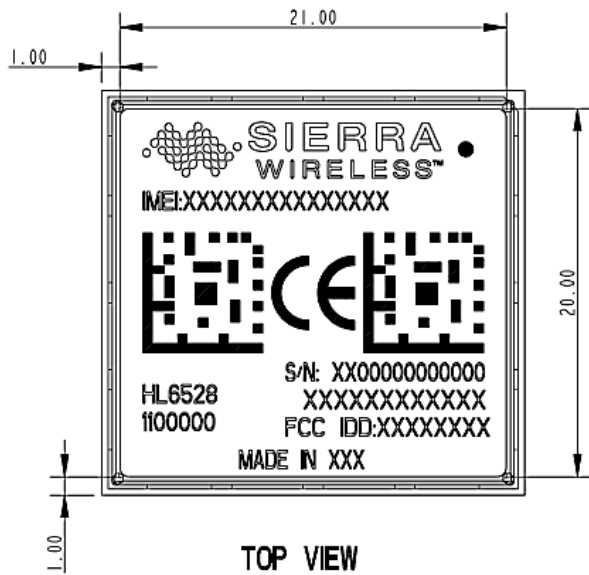
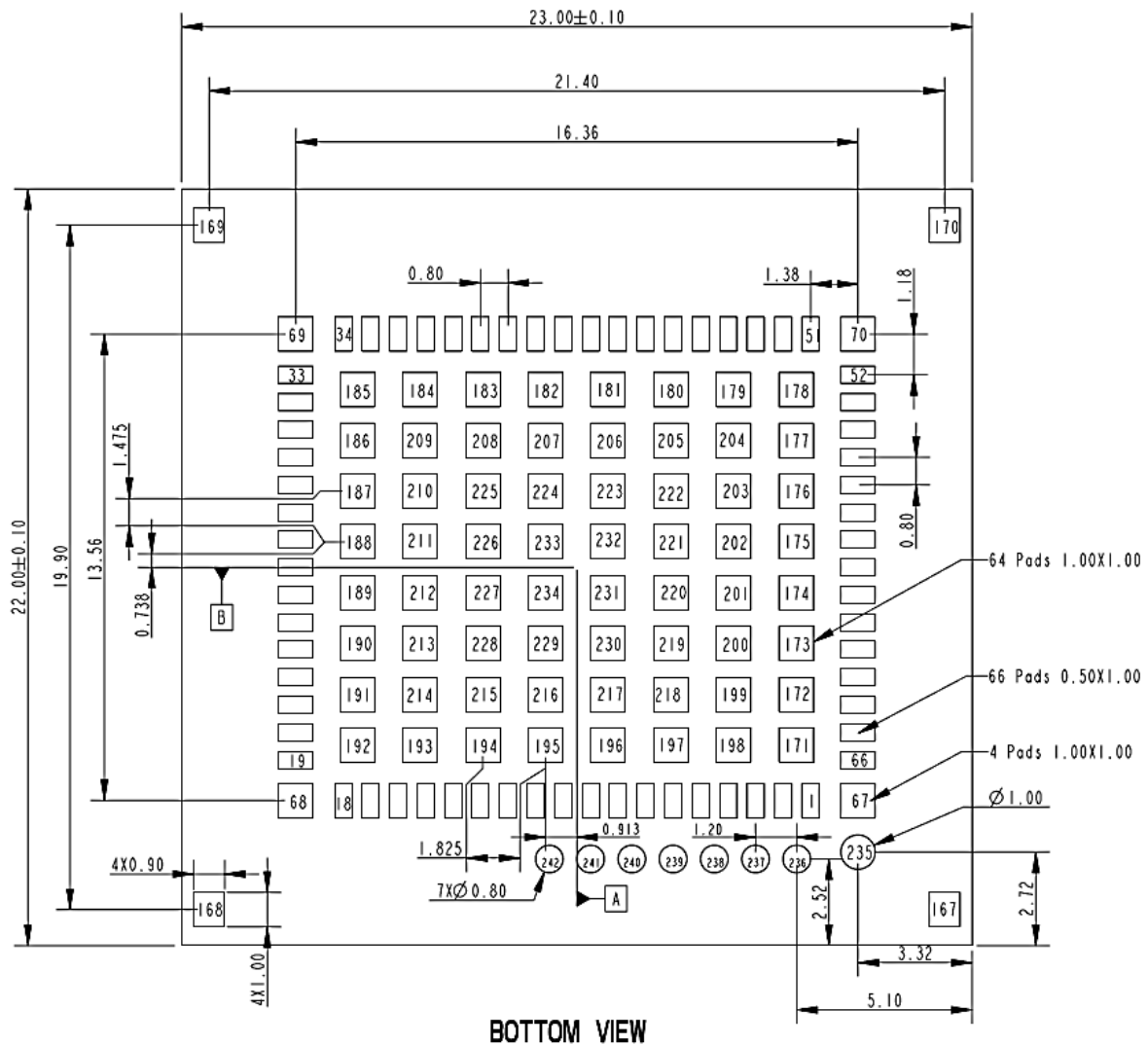

Figure 14. AirPrime HL6528RDx (side view)



TOP VIEW

Figure 15. AirPrime HL6528RDx Module (top view)



BOTTOM VIEW

Figure 16. AirPrime HL6528RDx Module (bottom view with dimensions)

# 5. Design Guidelines

## 5.1. Power On Sequence

The PWR\_ON\_N pad has the minimum assertion time requirement of 25 ms, with LOW active. Once the valid power on trigger is detected, the PWR\_ON\_N pad status can be left open.

VBATT should ramp up within 32 ms to reach the value of 3.35 V; otherwise, the module may not power up.

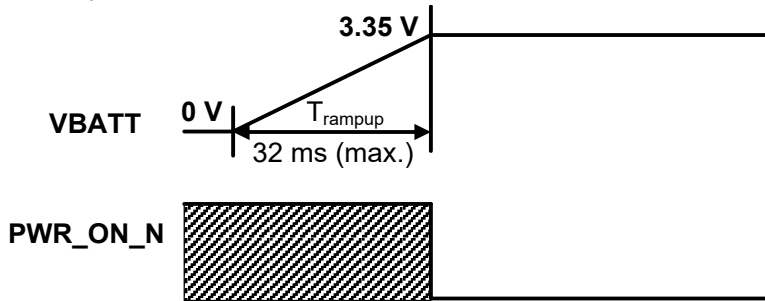

Figure 17. PWR\_ON\_N Sequence with  $T_{rampup}$

*Note:* As PWR\_ON\_N is internally pulled up with 100k $\Omega$ , a simple open collector or open drain transistor must be used for ignition.

Either UART1 or a USB interface could be used to send AT commands once the module has been powered on. Note that for USB connections, the time when AT commands can be sent will depend on the initialization time used for the USB connection with the USB host.

### 5.1.1. Using UART1

When using UART1 to send AT commands to the module, the HL6528RDx must be powered on by applying a low-level logic to the PWR\_ON\_N pad (pad 59). When CTS toggles to low level, the module is ready to receive AT commands.

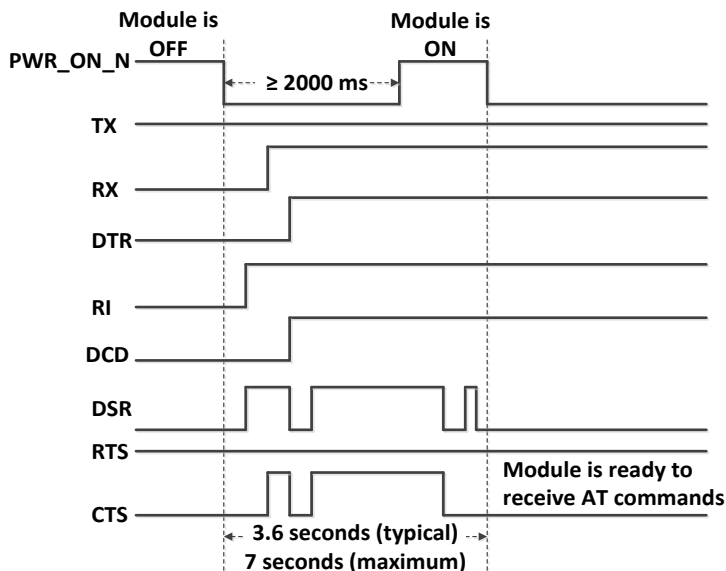

Figure 18. UART Signals during the Power ON Sequence

### 5.1.2. Using USB

When using USB to send AT commands to the module, the HL6528RDx must be powered on by applying a low-level logic to the PWR\_ON\_N pad (pad 59). VGPIO will appear to be ON within 25 ms; the module is then ready to receive AT commands.

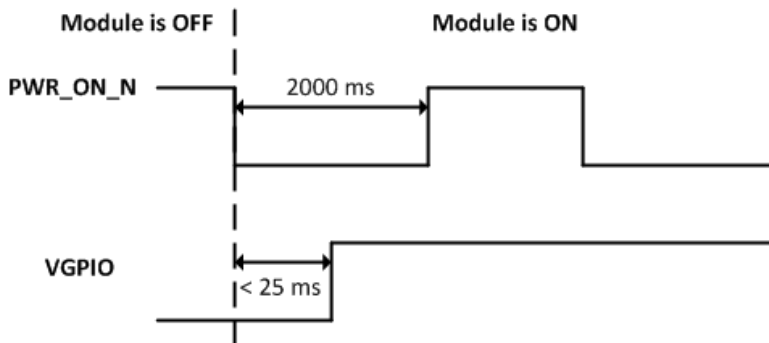

Figure 19. PWR\_ON\_N Sequence with VGPIO Information

### 5.2. Module Switch-Off

AT command `AT+PSCPOF` enables the user to properly switch the AirPrime HL6528RDx module off.

If required, the module can be switched off by controlling the power supply. This can be used, for example, when the system freezes and no reset line is connected to the AirPrime HL6528RDx module. In this case, the only way to get control back over the module is to switch off the power line.

PWR\_ON\_N, VGPIO and UART1\_CTS signal behavior during the power off sequence is described in the figure below.

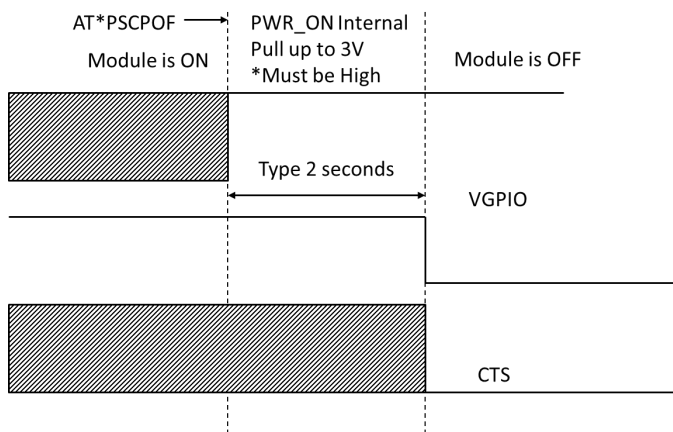

Figure 20. Power OFF Sequence for PWR\_ON\_N, VGPIO and UART1\_CTS

### 5.3. Sleep Mode Management

AT command `AT+KSLEEP` enables the sleep mode configuration.

`AT+KSLEEP=0:`

- The AirPrime HL6528RDx module is active when DTR signal is active (low electrical level).
- When DTR is deactivated (high electrical level), the AirPrime HL6528RDx module enters sleep mode after a while.
- On DTR activation (low electrical level), the AirPrime HL6528RDx module wakes up.



## 5.5. ESD Guidelines for USB

When the USB interface is externally accessible, it is required to have ESD protection on the USB\_VBUS, USB\_D+ and USB\_D- signals.

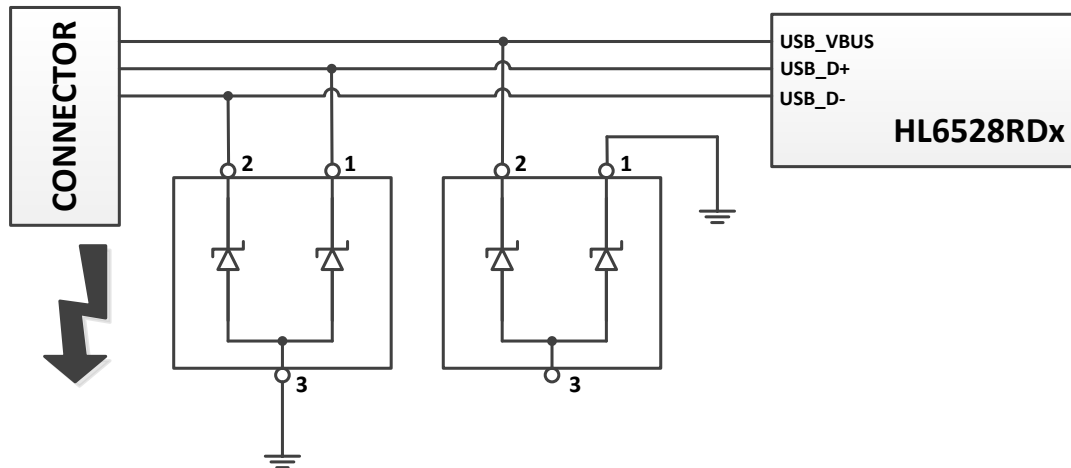

Figure 22. ESD Protection for USB

*Note:* It is not recommended to have an ESD diode with feedback path from USB\_VBUS to either USB\_D+ or USB\_D-.

## 5.6. ESD Guidelines for RF Interface

An ESD diode, placed close to the external antenna (main and GPS) ports, is highly recommended. Sierra Wireless recommends using the MURATA LXES15AAA1-117 as an ESD diode.

## 5.7. Power Supply

The AirPrime HL6528RDx module should not be supplied with voltage over 4.3 V even temporarily or however briefly.

If the system’s main board power supply unit is unstable or if the system’s main board is supplied with over 4.3 V, even in the case of transient voltage presence on the circuit, the HL6528RDx’s power amplifier and GPS chipset may be severely damaged.

To avoid such issues, add a voltage limiter to the module’s power supply lines so that VBATT and VBATT\_PA signal pads will never receive a voltage surge over 4.3 V. The voltage limiter can be as simple as a Zener diode as shown in the diagram below.

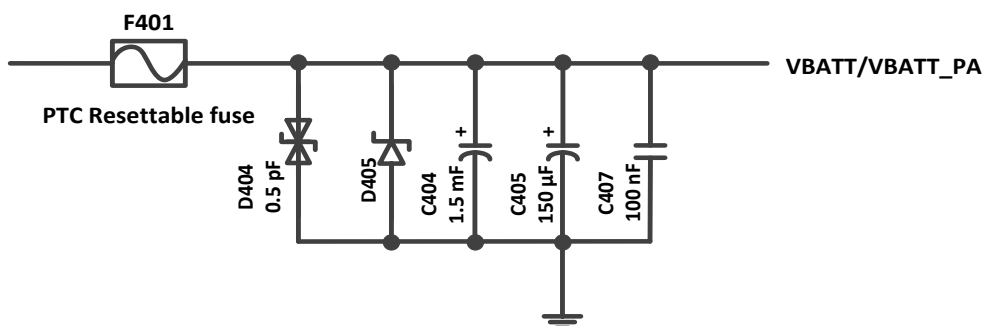

Figure 23. Voltage Limiter Example

## 5.8. Power Cycle

In addition to Sierra Wireless' reliable recovery mechanisms, it is highly recommended that the ability for a power cycle to reboot the module be included in the design in case the module becomes blocked and stops responding to reset commands.

## 5.9. Audio Integration

### 5.9.1. Microphone Audio Design

#### 5.9.1.1. Differential Connection Example

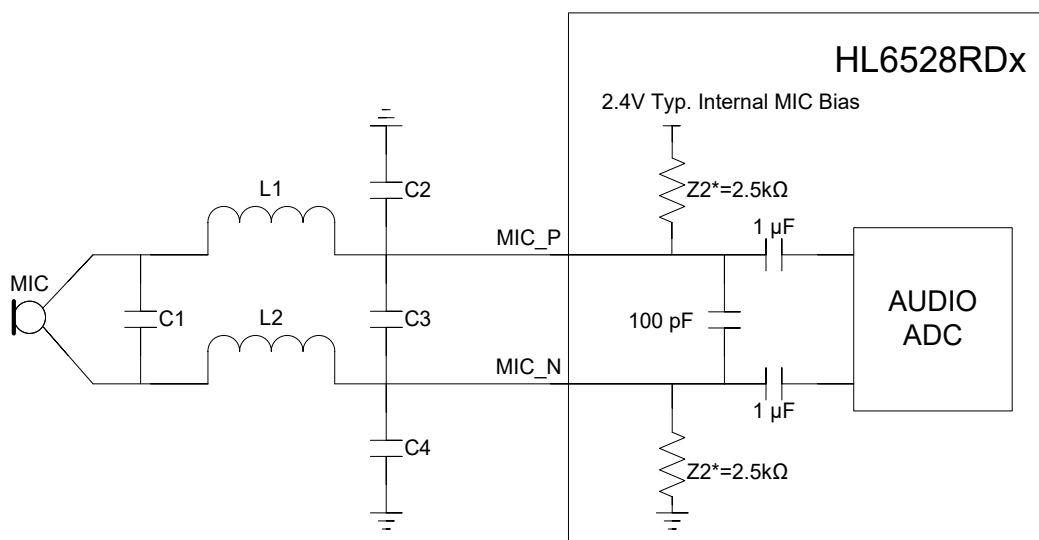

Figure 24. Example of a MIC Input Connection with LC Filter

The LC filter (L1, L2, C2, C3, and C4) is used to reduce EMI perturbation created by TDMA noise, but it is not mandatory. Good quality audio can be achieved without an LC filter depending on the design.

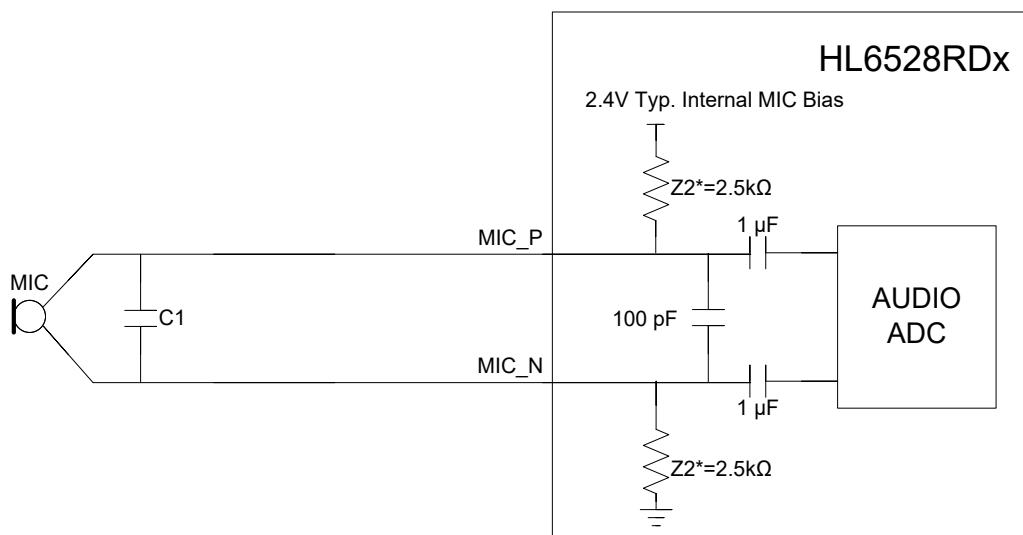

Figure 25. Example of a MIC Input Connection without LC Filter

Capacitor C1 is highly recommended to eliminate TDMA noise. Note that C1 must be close to the microphone.

Refer to the table below for the recommended components to use with a microphone connection.

**Table 44. Recommended Components for a Microphone Connection**

Component	Description/Details	Notes
C1	12pF to 33pF	Needs to be tuned depending on the design
C2, C3, C4	47pF	Needs to be tuned depending on the design
L1, L2	100nH	Needs to be tuned depending on the design

### 5.9.1.2. Single-Ended Connection Example

When a single-ended connection is used for MIC, MIC\_N is just left open.

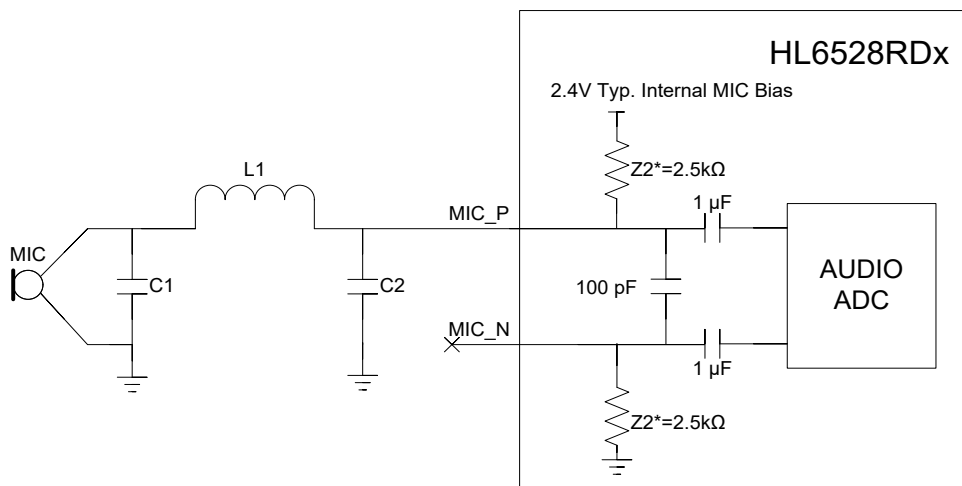

Figure 26. Example of a Single-Ended MIC Input Connection with LC Filter

The internal input impedance value becomes 1100Ω due to the connection of the other end to ground.

The single-ended design is very sensitive to TDMA noise; it is recommended to add L1 and C2 footprint as an LC filter to try to eliminate TDMA noise. Very good grounding on the MIC is required in order to ensure good performance against TDMA. Also, special care on the PCB layout must be taken.

When not used, the filter can be removed by replacing L1 with a 0Ω resistor and by disconnecting C2, as shown in the following figure.

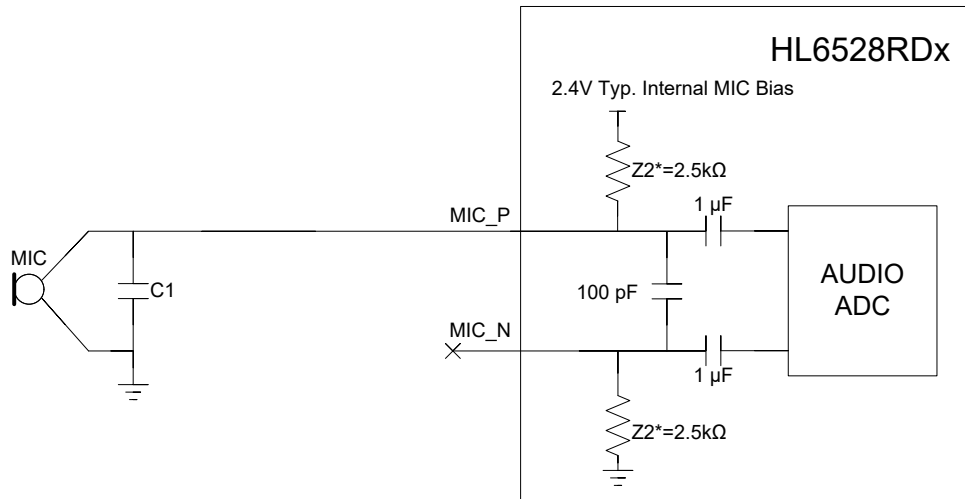

Figure 27. Example of a Single-Ended MIC Input Connection without LC Filter

The capacitor C1 is highly recommended to eliminate TDMA noise, and it must be placed close to the microphone.

Refer to the table below for the recommended components to use with a single-ended microphone connection.

Table 45. Recommended Components for a Single-Ended Microphone Connection

Component	Description/Details	Notes
C1	12pF to 33pF	Needs to be tuned depending on the design
C2	12pF to 33pF	Needs to be tuned depending on the design
L1	100nH	Needs to be tuned depending on the design

### 5.9.2. Speaker Audio Design

The SPKR interface can be used in a single-ended or a differential connection. However, it is strongly recommended to use a differential connection to reject common mode noise and TDMA noise. Moreover, in single-ended mode, half (1/2) of the power is lost.

When using a single-ended connection, be sure to have a very good ground plane, very good filtering as well as shielding to avoid any disturbance on the audio path.

The following table lists the typical values of both speaker output.

Table 46. Speaker Details

Parameter	Typical Value	Connection
Z (SPKR_P, SPKR_N) (Ω)	32	Differential mode
Z (SPKR_P, SPKR_N) (Ω)	32	Single-ended mode

It is recommended to add ESD protection to the speaker when it is exposed to the external environment. The ESD protection should be connected between the audio lines and a good ground, and placed as close to the speaker as possible.

It is important to select an appropriate speaker and filtering components to avoid TDMA noise.

### 5.9.2.1. SPKR Differential Connection

*Note:* Add a 33pF capacitor between the SPKR\_P and SPKR\_N pads to reduce TDMA noise.

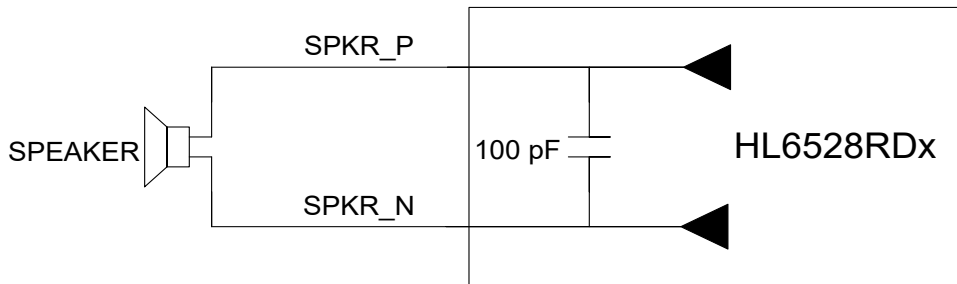

Figure 28. Example of a Differential Connection for SPKR

### 5.9.2.2. SPKR Single-Ended Connection

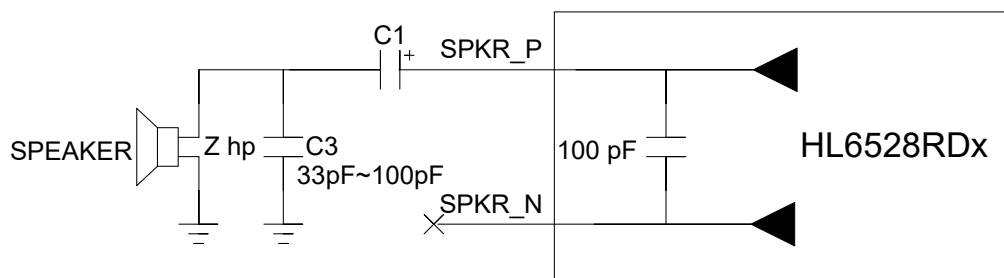

Figure 29. Example of a Single-Ended Speaker Connection (typical implementation)

In a single-ended connection:

- $4.7\mu\text{F} < C1 < 47\mu\text{F}$ , depending on the speaker characteristics and output power
- the connection between the AirPrime HL6528RDx module pads and the speaker must be designed to keep the serial impedance lower than  $1.5\Omega$
- SPKR\_N can be left open
- output power is lost (-6dB) as compared to a differential connection

### 5.9.3. Audio Layout Guidelines

To avoid TDMA noise, it is recommended to surround the audio tracks with ground as shown in the following figure.

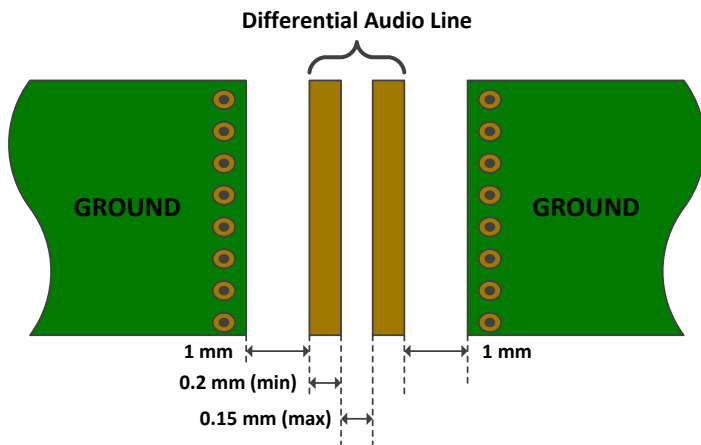

Figure 30. Audio Track Design

For differential connections, refer to the on following figure. Note that the differential audio line is always in parallel.

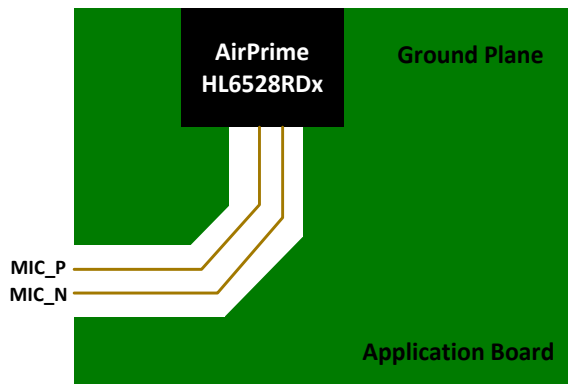

Figure 31. Differential Audio Connection

For single-ended connections, the negative pole of the microphone, MIC\_N, should be connected to GND. Refer to the following figure.

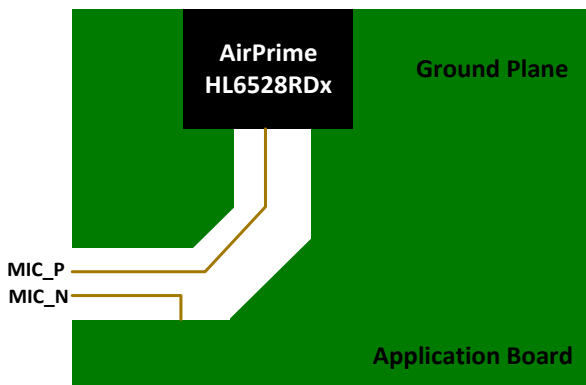

Figure 32. Single-Ended Audio Connection

---

**Caution:** Avoid digital tracks crossing under and over the audio tracks.

---

It is highly recommended to have the MIC ground and the LC filter ground to act as an audio analog ground during the PCB layout. This audio ground, together with the MIC\_P signal, should act as the differential line pair; and this audio ground should only be connected to the AirPrime HL6528RDx module ground, as close as possible to the LGA GND pad of the AirPrime HL6528RDx module. It is the same case for SPKR\_P and SPKR\_N.

Also, the audio interface is ESD sensitive. ESD protection MUST be added to the interface once it is externally accessible.

To avoid distortion and burst noise, the following guidelines should be followed:

- Audio signals must be symmetric (same components on each path)
- Differential signals must be routed in parallel
- Audio layer must be surrounded by 2 ground layers
- The link from one component to the ground must be as short as possible
- Separate the PCBs for the microphone and the speaker if possible
- Reduce the number of electronic components as much as possible (to avoid loss of quality and greater dispersion)

## 5.10. Radio Integration

### 5.10.1. GSM Antenna Integration with Antenna Detection Circuitry

The AirPrime HL6528RDx module is equipped with external antennas. A 50Ω line matching circuit between the module, the customer’s board and the RF antennas is required, for GSM and GPS feed path, as shown in the example below.

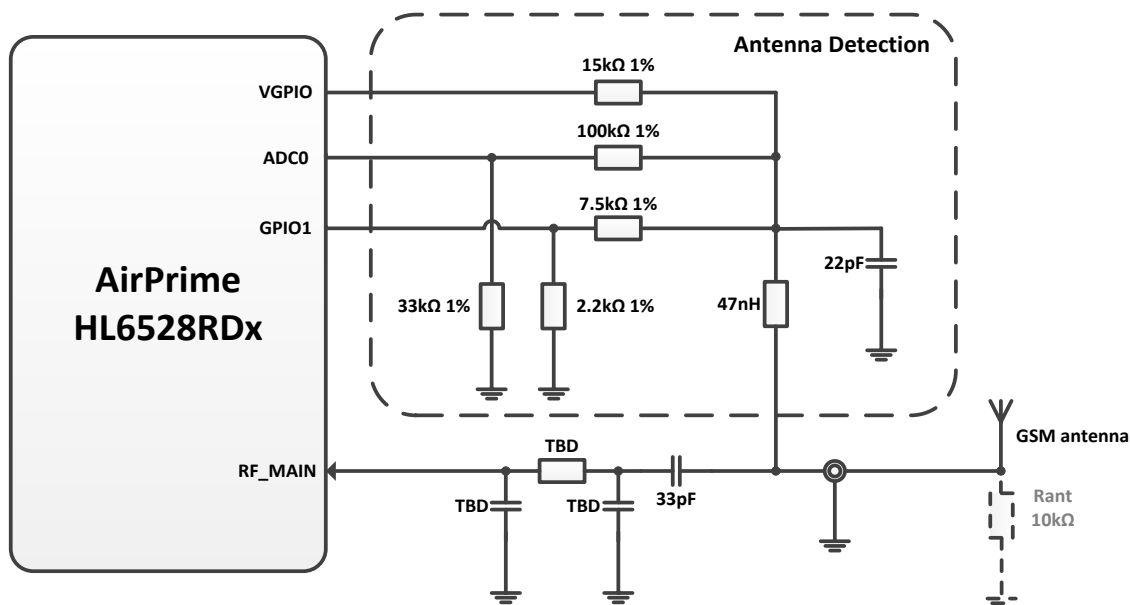

Figure 33. GSM Antenna Connection with Antenna Detection

**Note:** Antenna detection circuit is optional. Rant is the equivalent DC terminating resistor of the antenna. Rant should be close to 10KΩ.

### 5.10.2. GNSS Active Antenna Integration

The AirPrime HL6528RD-G and HL6528RD-G2.8V modules embed a GPS/GLONASS receiver inside. A possible implementation with an active GNSS antenna is defined below.

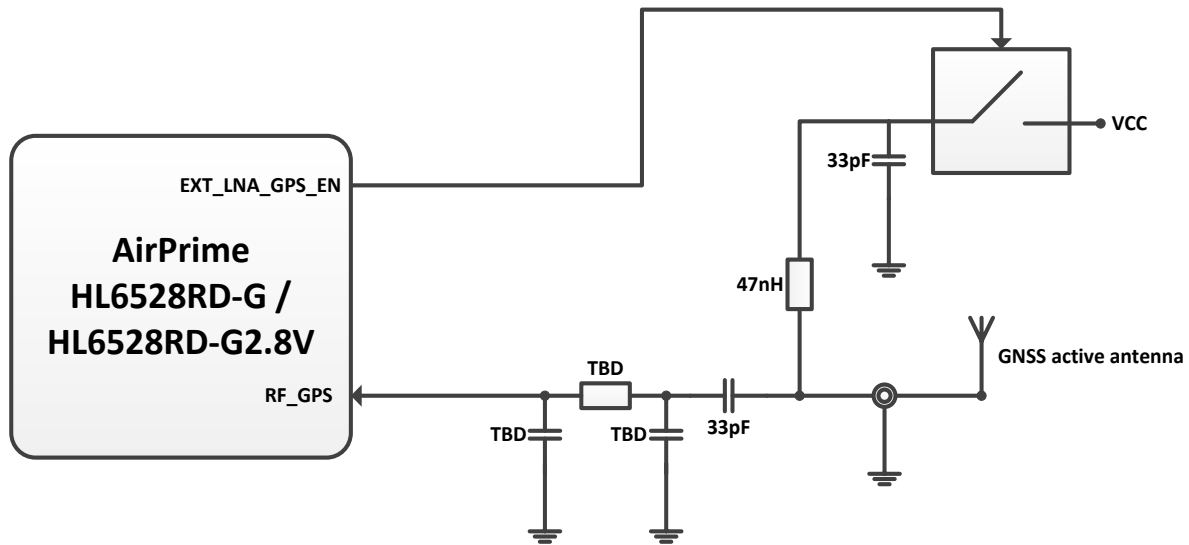

Figure 34. GNSS Application with Active Antenna

EXT\_LNA\_GPS\_EN is a specific signal that automatically sets the AirPrime HL6528RD-G and HL6528RD-G2.8V modules' internal LNA to low gain when an external pull-down resistor is detected.

---

*Note:* When the application needs to monitor the active antenna current, current monitor devices can be connected to any of the module's GPIOs, and read with a dedicated AT command.

---

### 5.11. Temperature Monitor

The AirPrime HL6528RDx module is embedded with an internal temperature monitor that can be used to determine the module's internal temperature. Refer to document [2] AirPrime HL6528RDx AT Commands Interface Guide for more information about configuring the internal temperature monitor.



## 6. Flash Memory Endurance

As with other embedded devices, the AirPrime HL6528RDx uses flash (or non-volatile) memory which guarantees a limited number of program/erasing cycles per sector (100,000 cycles). Although a state-of-the-art mechanism has been implemented to limit the number of writing/erasing cycles, Sierra Wireless recommends using “write” AT commands appropriately and always with caution. AT commands used to write to and configure the embedded module’s flash memory are enumerated in document [2] AirPrime HL6528RDx AT Commands Interface Guide.

# >> 7. Reliability Specification

The AirPrime HL6528RDx module is tested against the Sierra Wireless Industrial Reliability Specification defined below.

## 7.1. Reliability Compliance

The AirPrime HL6528RDx module connected on a development kit board application is compliant with the following requirements.

Table 47. Standards Conformity for the AirPrime HL6528RDx Embedded Modules

Abbreviation	Definition
IEC	International Electro technical Commission
ISO	International Organization for Standardization

## 7.2. Reliability Prediction Model

### 7.2.1. Life Stress Test

The following tests the AirPrime HL6528RDx module's product performances.

Table 48. Life Stress Test

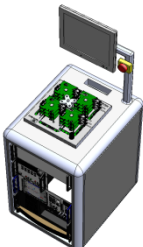
Designation	Condition
<b>Performance Test PT3T &amp; PTRT</b>  	Standard: N/A
	Special conditions: <ul style="list-style-type: none"> <li>• Temperature:               <ul style="list-style-type: none"> <li>▪ Class A: -30°C to +70°C</li> <li>▪ Class B: -40°C to +85°C</li> <li>▪ Rate of temperature change: ± 3°C/min</li> </ul> </li> <li>• Recovery time: 3 hours</li> </ul>
	Operating conditions: Powered
	Duration: 14 days

## 7.2.2. Environmental Resistance Stress Tests

The following tests the AirPrime HL6528RDx module’s resistance to extreme temperature.

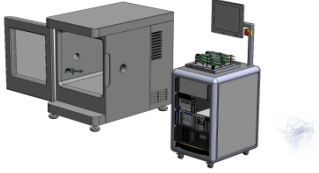
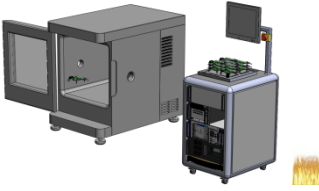
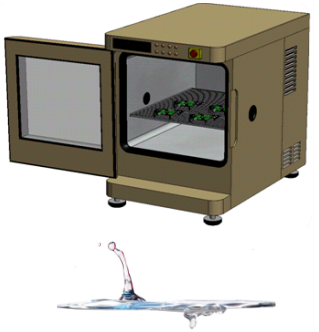

Table 49. Environmental Resistance Stress Tests

Designation	Condition
<b>Cold Test Active COTA</b> 	Standard: IEC 680068-2-1, Test Ad
	Special conditions: <ul style="list-style-type: none"> <li>• Temperature: -40°C</li> <li>• Temperature variation: 1°C/min</li> </ul>
	Operating conditions: Powered ON with a power cycle of 1 minute ON and 2 minutes OFF
	Duration: 3 days
<b>Resistance to Heat Test RH</b> 	Standard: IEC 680068-2-2, Test Bb
	Special conditions: <ul style="list-style-type: none"> <li>• Temperature: +85°C</li> <li>• Temperature variation: 1°C/min</li> </ul>
	Operating conditions: Powered ON with a power cycle of 15 minutes ON and 15 minutes OFF
	Duration: 50 days

## 7.2.3. Corrosive Resistance Stress Tests

The following tests the AirPrime HL6528RDx module’s resistance to corrosive atmosphere.

Table 50. Corrosive Resistance Stress Tests

Designation	Condition
<b>Humidity Test HUT</b> 	Standard: IEC 60068-2-3, Test Ca
	Special conditions: <ul style="list-style-type: none"> <li>• Temperature: +65°C</li> <li>• RH: 95%</li> <li>• Temperature variation: 3 ± 0.6°C/min</li> </ul>
	Operating conditions: Powered on, DUT is powered up for 15 minutes and OFF for 15 minutes
	Duration: 10 days
<b>Component Solder Wettability CSW</b> 	Standard: JESD22-B102, Method 1/Condition C, Solderability Test Method
	Special conditions: <ul style="list-style-type: none"> <li>• Test method: Dip and Look Test with Steam preconditioning 8 h ±15min. dip for 5 +0/-0.5 seconds</li> </ul>
	Operating conditions: Un-powered
	Duration: 1 days

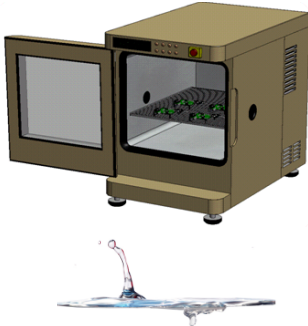
Designation	Condition
<b>Moist Heat Cyclic Test MHCT</b> 	Standard: IEC 60068-2-30, Test Db
	Special conditions: <ul style="list-style-type: none"> <li>• Upper temperature: <math>+40 \pm 2^\circ\text{C}</math></li> <li>• Lower temperature: <math>+25 \pm 5^\circ\text{C}</math></li> <li>• RH:                             <ul style="list-style-type: none"> <li>▪ Upper temperature: 93%</li> <li>▪ Lower temperature: 95%</li> </ul> </li> <li>• Number of cycles: 21 (1 cycle/24 hours)</li> <li>• Temperature Variation: <math>3 \pm 0.6^\circ\text{C}/\text{min}</math></li> </ul>
	Operating conditions: Powered ON for 15 minutes during each 3 hours ramp up and 3 hours ramp down (in middle) for every cycle
	Duration: 21 days

### 7.2.4. Thermal Resistance Cycle Stress Tests

The following tests the AirPrime HL6528RDx module’s resistance to extreme temperature cycling.

Table 51. Thermal Resistance Cycle Stress Tests

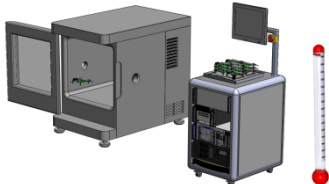
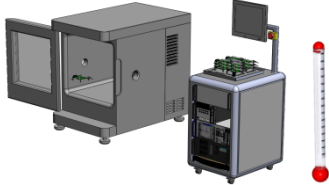
Designation	Condition
<b>Thermal Shock Test TSKT</b> 	Standard: IEC 60068-2-14, Test Na
	Special conditions: <ul style="list-style-type: none"> <li>• Temperature: <math>-30^\circ\text{C}</math> to <math>+80^\circ\text{C}</math></li> <li>• Temperature Variation: less than 30s</li> <li>• Number of cycles: 600</li> <li>• Dwell Time: 10 minutes</li> </ul>
	Operating conditions: Un-powered
	Duration: 9 days
<b>Temperature Change TCH</b> 	Standard: IEC 60068-2-14, Test Nb
	Special conditions: <ul style="list-style-type: none"> <li>• Temperature: <math>-40^\circ\text{C}</math> to <math>+90^\circ\text{C}</math></li> <li>• Temperature Variation: <math>3 \pm 0.6^\circ\text{C}/\text{min}</math></li> <li>• Number of cycles: 400</li> <li>• Dwell Time: 10 minutes</li> </ul>
	Operating conditions: Un-powered
	Duration: 29 days

## 7.2.5. Mechanical Resistance Stress Tests

The following tests the AirPrime HL6528RDx module’s resistance to vibrations and mechanical shocks.

Table 52. Mechanical Resistance Stress Tests

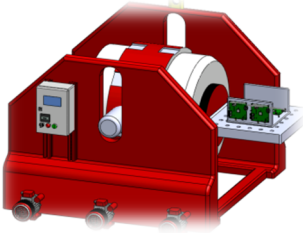
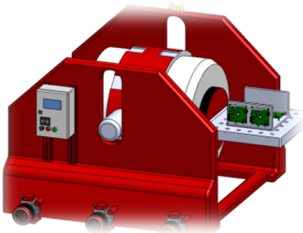
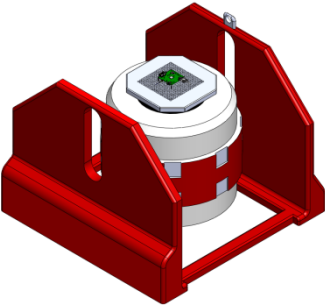

Designation	Condition
<p><b>Sinusoidal Vibration Test SVT</b></p> 	<p>Standard: IEC 60068-2-6, Test Fc</p> <p>Special conditions:</p> <ul style="list-style-type: none"> <li>• Frequency range: 16 Hz to 1000 Hz</li> <li>• Displacement: 0.35mm (peak-peak)</li> <li>• Acceleration:                             <ul style="list-style-type: none"> <li>▪ 5G from 16 to 62 Hz</li> <li>▪ 3G from 62 to 200 Hz</li> <li>▪ 1G from 200 to 1000 Hz</li> </ul> </li> <li>• Sweep rate: 1 octave / cycle</li> <li>• Number of Sweep: 20 sweeps/axis</li> <li>• Sweep direction: ±X, ±Y, ±Z</li> </ul> <p>Operating conditions: Un-powered</p> <p>Duration: 2 days</p>
<p><b>Random Vibration Test RVT</b></p> 	<p>Standard: IEC 60068-2-64, Test Fh</p> <p>Special conditions:</p> <ul style="list-style-type: none"> <li>• Frequency range: 10 Hz – 2000 Hz</li> <li>• Power Spectral Density in [(m/s<sup>2</sup>)<sup>2</sup>/Hz]                             <ul style="list-style-type: none"> <li>▪ 0.1 g<sup>2</sup>/Hz at 10Hz</li> <li>▪ 0.01 g<sup>2</sup>/Hz at 250Hz</li> <li>▪ 0.005 g<sup>2</sup>/Hz at 1000Hz</li> <li>▪ 0.005 g<sup>2</sup>/Hz at 2000Hz</li> </ul> </li> <li>• Peak factor: 3</li> <li>• Duration per Axis: 1 hr / axis</li> </ul> <p>Operating conditions: Un-powered</p> <p>Duration: 41 days</p>
<p><b>Mechanical Shock Test MST</b></p> 	<p>Standard: IEC 60068-2-27, Test Ea</p> <p>Special conditions:</p> <ul style="list-style-type: none"> <li>• Shock Test 1:                             <ul style="list-style-type: none"> <li>▪ Wave form: Half sine</li> <li>▪ Peak acceleration: 30g</li> <li>▪ Duration: 11ms</li> <li>▪ Number of shocks: 8</li> <li>▪ Direction: ±X, ±Y, ±Z</li> </ul> </li> <li>• Shock Test 2:                             <ul style="list-style-type: none"> <li>▪ Wave form: Half sine</li> <li>▪ Peak acceleration: 100g</li> <li>▪ Duration: 6ms</li> <li>▪ Number of shocks: 3</li> <li>▪ Direction: ±X, ±Y, ±Z</li> </ul> </li> </ul> <p>Operating conditions: Un-powered</p> <p>Duration: 72 hours</p>

## 7.2.6. Handling Resistance Stress Tests

The following tests test the AirPrime HL6528RDx module's resistance to handling malfunctions and damage.

**Caution:** *Special conditions for ESDC and ESD tests are not met on the GPS pad (pad 38).*

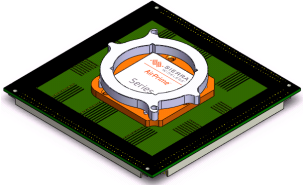
Table 53. Handling Resistance Stress Tests

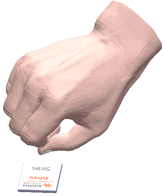
Designation	Condition
<b>ESDC Test</b> 	Standard: JESD22-A114, JESD22-A115, JESD 22-C101
	Special conditions: <ul style="list-style-type: none"> <li>• HBM (Human Body Model): 1500V (Class 1C)</li> <li>• MM (Machine Model): 150V (Class B)</li> <li>• CDM (Charged Device Model): 500V (Class III)</li> </ul>
	Operating conditions: Powered
	Duration: 3 days
<b>ESD Test</b> 	Standard: IEC 61000-4-2
	Special conditions: <ul style="list-style-type: none"> <li>• Contact Voltage: ±2kV, ±4kV, ±6kV</li> <li>• Air Voltage: ±2kV, ±4kV, ±8kV</li> </ul>
	Operating conditions: Powered
	Duration: 3 days
<b>Free Fall Test FFT 1</b> 	Standard: IEC 60068-2-32, Test Ed
	Special conditions: <ul style="list-style-type: none"> <li>• Number of drops: 2 drops per unit</li> <li>• Height: 1m</li> </ul>
	Operating conditions: Un-powered
	Duration: 6 hours

# 8. Regulatory Legal Information

## 8.1. Label

The AirPrime HL6528RDx module is labeled with its own FCC ID on the shield side. Each HL6528RDx variant has its own FCC ID as listed in the table below.

Table 54. AirPrime HL6528RDx FCC IDs

Model Name	FCC ID
HL6528RD	N7NHL6528RD
HL6528RD-G	N7NHL6528RDG
HL6528RD-2.8V	N7NHL6528RD28V
HL6528RD-G2.8V	N7NHL6528RDG28V

When the module is installed in a customer's product, the FCC ID label on the module will not be visible. To avoid this case, an exterior label must be stuck on the surface of the customer's product to indicate the FCC ID of the enclosed module. This label can use wording such as the following: "Contains Transmitter module FCC ID: <FCC ID as listed in Table 54 AirPrime HL6528RDx FCC IDs>" or "Contains FCC ID: <FCC ID as listed in Table 54 AirPrime HL6528RDx FCC IDs>".

## 8.2. FCC Regulations

This device complies with part 15 of the FCC Rules. Operation is subject to the following two conditions:

1. This device may not cause harmful interference, and
2. This device must accept any interference received, including interference that may cause undesired operation.

This device has been tested and found to comply with the limits for a Class B digital device, pursuant to Part 15 of the FCC Rules. These limits are designed to provide reasonable protection against harmful interference in a residential installation. This equipment can radiate radio frequency energy and, if not installed and used in accordance with the instructions, may cause harmful interference to radio communications. However, there is no guarantee that interference will not occur in a particular installation. If this equipment does cause harmful interference to radio or television reception, which can be determined by turning the equipment off and on, the user is encouraged to try to correct the interference by one or more of the following measures:

1. Reorient or relocate the receiving antenna.
2. Increase the separation between the equipment and receiver.
3. Connect the equipment into an outlet on a circuit different from that to which the receiver is connected.
4. Consult the dealer or an experienced radio/TV technician for help.

Changes or modifications not expressly approved by the party responsible for compliance could void the user's authority to operate the equipment.

## 8.3. RF Exposure Information

This Modular Approval is limited to OEM installation for mobile and fixed applications only. The antenna installation and operating configurations of this transmitter, including any applicable source-based time-averaging duty factor, antenna gain and cable loss must satisfy MPE categorical Exclusion Requirements of §2.1091.

The antenna(s) used for this transmitter must be installed to provide a separation distance of at least 20 cm from all persons, must not be collocated or operating in conjunction with any other antenna or transmitter, except in accordance with FCC multi-transmitter product procedures.

The end user has no manual instructions to remove or install the device and a separate approval is required for all other operating configurations, including portable configurations with respect to 2.1093 and different antenna configurations.

According to the MPE RF explore report, maximum antenna gain allowed for use with this device is 5.1 dBi for GSM 850 and 2.2 dBi for PCS 1900.

When the module is installed in the host device, the FCC ID label must be visible through a window on the final device or it must be visible when an access panel, door or cover is easily removed. Otherwise, a second label must be placed on the outside of the final device that contains the following text: —Contains FCC ID: <FCC ID as listed in Table 54 AirPrime HL6528RDx FCC IDs>

## 8.4. IC Regulations

IC Radiation Exposure Statement:

This device complies with Industry Canada license-exempt RSS standard(s). Operation is subject to the following two conditions:

1. this device may not cause interference, and
2. this device must accept any interference, including interference that may cause undesired operation of the device.

Le présent appareil est conforme aux CNR d'Industrie Canada applicables aux appareils radio exempts de licence. L'exploitation est autorisée aux deux conditions suivantes:

1. l'appareil ne doit pas produire de brouillage, et
2. l'utilisateur de l'appareil doit accepter tout brouillage radioélectrique subi, même si le brouillage est susceptible d'entraîner des comportements non-désirés

This Class B digital apparatus complies with Canadian ICES-003.

Cet appareil numérique de la classe B est conforme à la norme NMB-003 du Canada.

Under Industry Canada regulations, this radio transmitter may only operate using an antenna of a type and maximum (or lesser) gain approved for the transmitter by Industry Canada. To reduce potential radio interference to other users, the antenna type and its gain should be so chosen that the equivalent isotropically radiated power (e.i.r.p) is not more than necessary for successful communication.

Labeling Requirements for the Host Device (from Section 7.2, RSS RSP-100 issue 10, November 2014): The host device shall be properly labeled to identify the module within the host device. The Industry Canada certification label of a module shall be clearly visible at all times when installed in the host device, otherwise the host device must be labeled to display the Industry Canada certification number of the module, preceded by the words — Contains transmitter module, or the word — Contains, or similar wording expressing the same meaning, as follows: Contains transmitter module IC: <IC as listed in the table below>.

Table 55. AirPrime HL6528RDx IC IDs

Model Name	IC ID
HL6528RD	2417C-HL6528RD
HL6528RD-G	2417C-HL6528RDG
HL6528RD-2.8V	2417C-HL6528RD28V
HL6528RD-G2.8V	2417C-HL6528RDG28V

This device complies with IC radiation exposure limits set forth for an uncontrolled environment. In order to avoid the possibility of exceeding the IC radio frequency exposure limits, human proximity to the antenna shall not be less than 20 cm (8 inches) during normal operation.

Cet appareil est conforme aux limites d'exposition aux rayonnements de la IC CNR-102 définies pour un environnement non contrôlé. Afin d'éviter la possibilité de dépasser les limites d'exposition aux fréquences radio de la IC CNR-102, la proximité humaine à l'antenne ne doit pas être inférieure à 20 cm (8 pouces) pendant le fonctionnement normal.

This radio transmitter (identify the device by certification number, or model number if Category II) has been approved by Industry Canada to operate with the antenna types listed below with the maximum permissible gain and required antenna impedance for each antenna type indicated. Antenna types not included in this list, having a gain greater than the maximum gain indicated for that type, are strictly prohibited for use with this device.

## 8.5. CE

The AirPrime HL6528RDx module complies with the applicable requirements in ETSI EN 301 511 V9.0.2 covering the essential requirements of Article 3.2 of Directive 2014/53/EU (Radio Equipment Directive; RED).

## >> 9. Ordering Information

Model Name	Description	Part Number
HL6528RD	HL6528RD embedded module	Contact Sierra Wireless for the latest SKU
HL6528RD-G	HL6528RD-G embedded module	Contact Sierra Wireless for the latest SKU
HL6528RD-2.8V	HL6528RD-2.8V embedded module	Contact Sierra Wireless for the latest SKU
HL6528RD-G2.8V	HL6528RD-G2.8V embedded module	Contact Sierra Wireless for the latest SKU
DEV-KIT	HL Series Development Kit	6000620



## 10. Terms and Abbreviations

Abbreviation	Definition
ADC	Analog to Digital Converter
AGC	Automatic Gain Control
AT	Attention (prefix for modem commands)
AVL	Automatic Vehicle Location
CCB	Customer Carrier Board
CDMA	Code Division Multiple Access
CF3	Common Flexible Form Factor
CLK	Clock
CODEC	Coder Decoder
CPU	Central Processing Unit
DAC	Digital to Analog Converter
DTR	Data Terminal Ready
EGNOS	European Geostationary Navigation Overlay Service
EMC	Electromagnetic Compatibility
EMI	Electromagnetic Interference
EN	Enable
ESD	Electrostatic Discharges
ETSI	European Telecommunications Standards Institute
FDMA	Frequency-division multiple access
GAGAN	GPS aided geo augmented navigation
GLONASS	Global Navigation Satellite System
GND	Ground
GNSS	Global Navigation Satellite System
GPIO	General Purpose Input Output
GPRS	General Packet Radio Service
GSM	Global System for Mobile communications
Hi Z	High impedance (Z)
IC	Integrated Circuit
IMEI	International Mobile Equipment Identification
I/O	Input / Output
LED	Light Emitting Diode
LNA	Low Noise Amplifier
MAX	Maximum
MIN	Minimum
MSAS	Multi-functional Satellite Augmentation System
N/A	Not Applicable
PA	Power Amplifier
PC	Personal Computer
PCB	Printed Circuit Board
PCL	Power Control Level

<b>Abbreviation</b>	<b>Definition</b>
PLL	Phase Lock Loop
PWM	Pulse Width Modulation
QZSS	Quasi-Zenith Satellite System
RF	Radio Frequency
RFI	Radio Frequency Interference
RMS	Root Mean Square
RST	Reset
RTC	Real Time Clock
RX	Receive
SCL	Serial Clock
SDA	Serial Data
SIM	Subscriber Identification Module
SMD	Surface Mounted Device/Design
SPI	Serial Peripheral Interface
SV	Satellite Vehicle
SW	Software
PSRAM	Pseudo Static RAM
TBC	To Be Confirmed
TBD	To Be Defined
TP	Test Point
TTS	Text To Speech
TX	Transmit
TYP	Typical
UART	Universal Asynchronous Receiver-Transmitter
UICC	Universal Integrated Circuit Card
USB	Universal Serial Bus
UIM	User Identity Module
VBATT	Main Supply Voltage from Battery or DC adapter
VSWR	Voltage Standing Wave Ratio
WAAS	Wide Area Augmentation System