



AirPrime WP75xx/WP8548

Product Technical Specification



SIERRA
WIRELESS®

4116440
Rev 15

Important Notice

Due to the nature of wireless communications, transmission and reception of data can never be guaranteed. Data may be delayed, corrupted (i.e., have errors) or be totally lost. Although significant delays or losses of data are rare when wireless devices such as the Sierra Wireless modem are used in a normal manner with a well-constructed network, the Sierra Wireless modem should not be used in situations where failure to transmit or receive data could result in damage of any kind to the user or any other party, including but not limited to personal injury, death, or loss of property. Sierra Wireless accepts no responsibility for damages of any kind resulting from delays or errors in data transmitted or received using the Sierra Wireless modem, or for failure of the Sierra Wireless modem to transmit or receive such data.

Safety and Hazards

Do not operate the Sierra Wireless modem in areas where blasting is in progress, where explosive atmospheres may be present, near medical equipment, near life support equipment, or any equipment which may be susceptible to any form of radio interference. In such areas, the Sierra Wireless modem **MUST BE POWERED OFF**. The Sierra Wireless modem can transmit signals that could interfere with this equipment.

Do not operate the Sierra Wireless modem in any aircraft, whether the aircraft is on the ground or in flight. In aircraft, the Sierra Wireless modem **MUST BE POWERED OFF**. When operating, the Sierra Wireless modem can transmit signals that could interfere with various onboard systems.

Note: Some airlines may permit the use of cellular phones while the aircraft is on the ground and the door is open. Sierra Wireless modems may be used at this time.

The driver or operator of any vehicle should not operate the Sierra Wireless modem while in control of a vehicle. Doing so will detract from the driver or operator's control and operation of that vehicle. In some states and provinces, operating such communications devices while in control of a vehicle is an offence.

Limitation of Liability

The information in this manual is subject to change without notice and does not represent a commitment on the part of Sierra Wireless. SIERRA WIRELESS AND ITS AFFILIATES SPECIFICALLY DISCLAIM LIABILITY FOR ANY AND ALL DIRECT, INDIRECT, SPECIAL, GENERAL, INCIDENTAL, CONSEQUENTIAL, PUNITIVE OR EXEMPLARY DAMAGES INCLUDING, BUT NOT LIMITED TO, LOSS OF PROFITS OR REVENUE OR ANTICIPATED PROFITS OR REVENUE ARISING OUT OF THE USE OR INABILITY TO USE ANY SIERRA WIRELESS PRODUCT, EVEN IF SIERRA WIRELESS AND/OR ITS AFFILIATES HAS BEEN ADVISED OF THE POSSIBILITY OF SUCH DAMAGES OR THEY ARE FORESEEABLE OR FOR CLAIMS BY ANY THIRD PARTY.

Notwithstanding the foregoing, in no event shall Sierra Wireless and/or its affiliates aggregate liability arising under or in connection with the Sierra Wireless product, regardless of the number of events, occurrences, or claims giving rise to liability, be in excess of the price paid by the purchaser for the Sierra Wireless product.

Patents

This product may contain technology developed by or for Sierra Wireless Inc. This product includes technology licensed from QUALCOMM®. This product is manufactured or sold by Sierra Wireless Inc. or its affiliates under one or more patents licensed from MMP Portfolio Licensing.

Copyright

©2019 Sierra Wireless. All rights reserved.

Trademarks

Sierra Wireless®, AirPrime®, AirLink®, AirVantage® and the Sierra Wireless logo are registered trademarks of Sierra Wireless, Inc.

Windows® and Windows Vista® are registered trademarks of Microsoft Corporation.

QUALCOMM® is a registered trademark of QUALCOMM Incorporated. Used under license.

Other trademarks are the property of their respective owners.

Contact Information

Sales information and technical support, including warranty and returns	Web: sierrawireless.com/company/contact-us/ Global toll-free number: 1-877-687-7795 6:00 am to 6:00 pm PST
Corporate and product information	Web: sierrawireless.com

Revision History

Revision number	Release date	Changes
7	February 2016	Updated Table 3-9, WP8548 Current Consumption Values , on page 44 Updated Table 3-12, Conducted Tx Max Output Power Tolerances—GSM , on page 46 Updated Table 3-14, WP8548 Conducted Rx Sensitivity—GSM/EDGE Bands , on page 47 Updated Table 3-15, Conducted Tx Max Output Power Tolerances—WCDMA , on page 48 Updated Table 3-18, WP8548 Conducted Rx Sensitivity—WCDMA Bands , on page 49 Updated RF Circuit on page 96 Updated Important Compliance Information for North American Users on page 114

Revision number	Release date	Changes
8	March 2016	<p>Updated GPS frequency range and added Galileo.</p> <p>Updated I2C1_CLK references from 'O' to 'I/O'.</p> <p>Removed DRX_IQ from Figure 2-3 on page 25.</p> <p>Removed 'sku-dependent' notes from GNSS availability throughout document.</p> <p>Updated Power Supply Ratings on page 35 description, Table 3-2 on page 36, Table 3-4 on page 36, and added Figure 3-1 on page 37.</p> <p>Updated current consumption descriptions and values in Table 3-6 on page 39, Figure 3-3 on page 40, and Table 3-9 on page 44.</p> <p>Added Active State to ULPM Transition on page 41.</p> <p>Updated POWER_ON_N on page 69 (momentary switch recommendation) Table 4-3 on page 69, and Figure 4-1 on page 70 (POWER_ON_N and SAFE_PWR_REMOVE signals).</p> <p>Exposed additional GPIOs — General Purpose Input/Output (GPIO) on page 74, Figure 10-1 on page 118, Table 10-1 on page 119).</p> <p>Exposed additional ADCs — ADC on page 80, Figure 10-1 on page 118, Table 10-1 on page 119).</p> <p>Removed pins (for GPIOs/ADCs) from Table 10-4 on page 125.</p> <p>Removed auxiliary PCM timing content.</p> <p>Added RF trace design requirement to Important Compliance Information for North American Users on page 114</p>
9	April 2016	<p>Updated Table 9-3 on page 117 (Column heading—EIRP values; marked unused cells as '—')</p>
10	September 2016	<p>Merged in content from 4118045 rev3 WP75XX PTS</p> <p>Added chapter: Testing on page 134.</p> <p>Updated Coin cell voltage in Table 4-2 on page 68.</p> <p>Updated idle/Airplane mode current consumption, and removed sleep mode current consumption in WP8548 Current Consumption Values on page 44.</p> <p>Added note indicating UART1 (8-wire) software support will be in future f/w release.</p> <p>Added notes indicating ADC2/ADC3 will be available as wakeup pins in future f/w release.</p>
11	October 2016	<p>Added warning to Power Supply Ratings on page 35.</p> <p>Added GPIO note to ULP M description (Table 3-6 on page 39).</p> <p>Added warnings/notes and module-specific voltage values to Absolute Maximum Ratings on page 59.</p> <p>Updated SAFE_PWR_REMOVE in Figure 4-1 on page 70.</p> <p>Added ULPM note in General Purpose Input/Output (GPIO) on page 74 and updated Default State in Table 4-8 on page 75.</p> <p>Corrected footnote (signal direction) for UART signals in Table 10-1 on page 119.</p> <p>Marked ADC0-3 as supported.</p> <p>Clarified ADC2-3 to be available (in future update) to wake-up from ULPM, not USB-SS mode.</p> <p>Added Japan certification.</p>

Revision number	Release date	Changes
12	December 2016	<p>Clarified USB-SS mode as supported only if ECH disabled or USB disconnected</p> <p>Added Table 3-32, Digital I/O Characteristics (VDD_PX=1.20 V (nominal)), on page 60</p> <p>Updated list—Wakeup Interrupt (USB-SS Mode) on page 76</p> <p>Updated list—Wakeup Events (ULPM) on page 76</p> <p>Noted sensitivity decrease for snap-in sockets</p> <p>Updated temperature recommendation in Module Testing Recommendations on page 104</p> <p>Updated GSM current consumption values—Table 3-7 on page 41, Table 3-9 on page 44</p> <p>Updated architecture (added GPIO28, GPIO29, GPIO30, GPIO31)</p> <p>Updated Active State to ULPM Transition on page 41</p> <p>8-wire UART1 now fully supported</p> <p>Updated SPI supported clock speeds in SPI Bus on page 84</p> <p>Corrected HSIC I/O type—Table 4-25 on page 86</p> <p>Updated Figure 5-4 on page 100—ESD for UIM1_DET</p> <p>Added chapter Reliability Specification on page 107</p>
13	May 2017	<p>Added triggers (GPIO39,ADC2,ADC3) to Figure 3-3, Power State Transitions, on page 40</p> <p>Updated Embedded Memory on page 63 and added write cycles detail</p> <p>Added ULPM charging note in BAT_RTC on page 68</p> <p>Added details to I2C Interface on page 77</p> <p>Removed references to UART2_RTS and UART2_CTS (not supported) throughout document, marked pins as reserved</p> <p>Removed reference to EXT_GPS_LNA_EN (pin 43) and marked as reserved</p> <p>Clarified usage of !DAWSPARANGE in UMTS (WCDMA) RF Transmission Path Test on page 138</p>
14	November 2018	<p>Removed COEX alternative signal names from pin table</p> <p>Removed statements indicating firmware upgrades supported on UART interface</p> <p>Updated Pin Configuration image</p> <p>Updated Software-initiated Power Down procedure</p>
15	February 2019	<p>Added GPS week rollover note</p> <p>Corrected Figure 4-1 Signal Timing (start/end positions of t_pwr_remove)</p> <p>Added resistor value to POWER_ON_N electrical characteristics table</p> <p>Updated PCM codec timing diagrams (removed t_hsync)</p>

>> Contents

Introduction	18
General Features	18
Interfaces	20
Common Flexible Form Factor (CF3)	21
Physical Dimensions and Connection Interface	21
Functional Specifications	23
Architecture	23
Chipsets	25
Telecom Features	26
Network Technology Specifications	29
Modem Specifications	34
Multi-Core Processing Capabilities	34
Technical Specifications	35
Environmental	35
Power Supply Ratings	35
Under-Voltage Lockout (UVLO)	37
Power Consumption States	38
Active State to ULPM Transition	41
Current Consumption	41
RF	45
GSM RF Interface	46
WCDMA RF Interface	48
CDMA RF Interface	49
LTE RF Interface	50
WWAN Antenna Interface	52
GNSS	56
GNSS Characteristics	56
GNSS Antenna Interface	57

Electrical Specifications	58
Absolute Maximum Ratings	59
Digital I/O Characteristics	60
Internal Device Frequencies	62
Processing	62
Application Core	62
Embedded Memory	63
Recovery Mechanisms	65
Mechanical Drawing.	66
Interfaces Specification	68
Overview	68
BAT_RTC.	68
POWER_ON_N	69
Power-up Sequence	69
Software-Initiated Power Down	70
Emergency Power Off	71
USB	71
UART	71
UIM interface	72
General Purpose Input/Output (GPIO)	74
Wakeup Interrupt (USB-SS Mode).	76
Wakeup Events (ULPM)	76
Secure Digital IO (SDIO) interface.	76
I2C Interface	77
Application	78
VGPIO	78
Reset Signal (RESET_IN_N).	79
Reset Out (RESET_OUT_N).	80
ADC	80

Digital Audio	81
PCM	82
I2S	83
SPI Bus	84
SPI Configuration	85
SPI Waveforms	85
Application	86
HSIC Bus	86
HSIC Waveforms	87
Application	87
Clock	87
TP1 (Boot Pin)	87
Temperature Monitoring	88
Test Pins	89
Antenna Control	90
Indication Interfaces	90
Tx Activity Indicator (TX_ON)	91
WWAN_LED_N	91
WAKE_ON_WWAN	92
Ring Indicator	92
SAFE_PWR_REMOVE	92
UIM1_DET/UIM2_DET	92
DR_SYNC	93
W_DISABLE_N—Wireless Disable	93
Routing Constraints and Recommendations	94
General Rules and Recommendations	94
PCB Layout Recommendations	94
Power Supply	94
Antenna	94
PCB Specifications for the Application Board	95
Recommended PCB Land Pattern	95

Routing Constraints	95
Power Supply	95
UIM Interface	96
RF Circuit	96
USB Interface	98
Thermal Considerations.	98
EMC and ESD Recommendations.	99
Mechanical Integration.	100
Signal Reference Schematics	100
Software and Tools	102
Support Tools.	102
SED (Smart Error Detection)	102
Firmware Upgrade	102
Operating System Upgrade	102
Labeling	103
Debug and Assembly Considerations	104
Testing Assistance Provided by Sierra Wireless	104
Integration Requirements.	104
IOT/Operator	104
Module Testing Recommendations	104
Serial Link Access	105
RF Output Accessibility	105
Reliability Specification	107
Reliability Compliance	107

Reliability Prediction Model	107
Life Stress Test	107
Environmental Resistance Stress Tests	108
Corrosive Resistance Stress Tests	108
Thermal Resistance Cycle Stress Tests	109
Mechanical Resistance Stress Tests	110
Handling Resistance Stress Tests	112
Approval	113
RoHS Directive Compliance	113
Disposing of the Product	113
Important Notice.	113
Safety and Hazards	113
Compliance Acceptance and Certification	114
Regulatory Compliance	114
Important Compliance Information for North American Users	114
Japan Regulatory Compliance	116
Pinout	117
Pin Configuration	118
Pin Description.	118
Customization	126
References	127
Web Site Support.	127
Reference Documents	127
Abbreviations	128
Testing	134
Certification Testing	134
Production Testing	134

Functional Production Test	135
Suggested Production Tests	135
Production Test Procedure	135
UMTS (WCDMA) RF Transmission Path Test.	138
LTE RF Transmission Path Test (WP75xx).	140
UMTS (WCDMA) RF Receive Path Test	142
LTE RF Receive Path Test (WP75xx)	145
GNSS RF Receive Path Test.	147
Safety Recommendations (For Information Only)	148
RF Safety.	148
General	148
Exposure to RF Energy	148
Efficient Terminal Operation	148
Antenna Care and Replacement	149
General Safety.	149
Driving	149
Electronic Devices	149
Vehicle Electronic Equipment	149
Medical Electronic Equipment	149
Aircraft	149
Children	150
Blasting Areas	150
Potentially Explosive Atmospheres	150

>> List of Figures

Figure 1-1: AirPrime WP75xx/AirPrime WP8548 Mechanical Overview	22
Figure 2-1: AirPrime WP7502 Architecture Overview	23
Figure 2-2: AirPrime WP7504 Architecture Overview	24
Figure 2-3: AirPrime WP8548 Architecture Overview	25
Figure 3-1: Power Supply Characteristics (capture enlarged)	37
Figure 3-2: Under-Voltage Lockout (UVLO) Diagram	37
Figure 3-3: Power State Transitions	40
Figure 3-4: Flash Memory Partitions	64
Figure 3-5: AirPrime WP75xx/AirPrime WP8548 Mechanical Drawings	67
Figure 4-1: Signal timing (POWER_ON_N, and USB Enumeration)	70
Figure 4-2: Recommended UIM Holder Implementation	73
Figure 4-3: Example of I2C Bus Application	78
Figure 4-4: Illustration of Reset Timing When RESET_IN_N < Trdel	79
Figure 4-5: PCM_SYNC Timing Diagram (2048 kHz clock)	83
Figure 4-6: PCM Codec to Device Timing Diagram	83
Figure 4-7: Device to PCM Codec Timing Diagram	83
Figure 4-8: I2S Transmitter Timing	84
Figure 4-9: 4-Wire Configuration SPI Transfer	85
Figure 4-10: Example of 4-wire SPI Bus Application	86
Figure 4-11: Example of 2-wire HSIC Bus Application	87
Figure 4-12: Temperature Monitoring State Machine	88
Figure 4-13: LED Reference Circuit	91
Figure 4-14: Recommended WAKE_ON_WWAN Connection	92
Figure 4-15: Recommended Wireless Disable Connection	93
Figure 5-1: Power Supply Routing Example	95
Figure 5-2: Module Location on Development Board	97
Figure 5-3: Development Board RF Trace Design	98
Figure 5-4: UIM Interface	100
Figure 5-5: USB Interface	101
Figure 5-6: USB OTG Interface	101

Figure 6-1: Unit Label Example (Contents will vary by SKU)	103
Figure 7-1: Level Shifter Implementation for UART1 Serial Link Access	105
Figure 10-1: Pin Configuration (Top View)	118

>> List of Tables

Table 1-1: WP7502 Supported Bands/Connectivity	18
Table 1-2: WP7504 Supported Bands/Connectivity	19
Table 1-3: WP8548 Supported Bands/Connectivity	20
Table 1-4: AirPrime WP75xx/AirPrime WP8548 Dimensions	21
Table 2-1: AirPrime WP75xx/AirPrime WP8548 Capabilities	26
Table 2-2: WP7502 RF Bands/Connectivity	27
Table 2-3: WP7504 RF Bands/Connectivity	27
Table 2-4: WP8548 RF Bands/Connectivity	28
Table 2-5: Supported GSM/GPRS/EDGE Specifications	29
Table 2-6: Supported WCDMA Specifications	30
Table 2-7: Supported LTE Specifications	32
Table 2-8: Supported CDMA Specifications	33
Table 2-9: Supported Modem Specifications	34
Table 3-1: Environmental Specifications	35
Table 3-2: Absolute Maximum Ratings	36
Table 3-3: Power Supply Pins	36
Table 3-4: Operating Conditions	36
Table 3-5: UVLO Specifications	38
Table 3-6: Supported Power States	39
Table 3-7: WP7502 Current Consumption Values	41
Table 3-8: WP7504 Current Consumption Values	42
Table 3-9: WP8548 Current Consumption Values	44
Table 3-10: ULPM Current Consumption	45
Table 3-11: Standards Compliance	46
Table 3-12: Conducted Tx Max Output Power Tolerances—GSM	46
Table 3-13: WP7502 Conducted Rx Sensitivity—GSM/EDGE Bands	47
Table 3-14: WP8548 Conducted Rx Sensitivity—GSM/EDGE Bands	47
Table 3-15: Conducted Tx Max Output Power Tolerances—WCDMA	48
Table 3-16: WP7502 Conducted Rx Sensitivity—WCDMA Bands	48
Table 3-19: WP7504 Conducted Tx Max Output Power Tolerances—CDMA	49

Table 3-17: WP7504 Conducted Rx Sensitivity—WCDMA Bands	49
Table 3-18: WP8548 Conducted Rx Sensitivity—WCDMA Bands	49
Table 3-20: Conducted Rx Sensitivity—CDMA Bands ,	50
Table 3-21: WP7502 Conducted Tx Max Output Power Tolerances—LTE	50
Table 3-23: WP7502 Conducted Rx Sensitivity—LTE Bands	51
Table 3-22: WP7504 Conducted Tx Max Output Power Tolerances—LTE	51
Table 3-24: WP7504 Conducted Rx Sensitivity—LTE Bands	52
Table 3-25: WP75xx WWAN Antenna Interface Pins	52
Table 3-27: Antenna Recommendations	53
Table 3-26: WP8548 WWAN Antenna Interface Pins	53
Table 3-28: GNSS Characteristics	56
Table 3-29: GNSS Antenna Interface Pads	57
Table 3-30: GNSS Standalone Antenna Recommendations	57
Table 3-31: Absolute Maximum Ratings	59
Table 3-32: Digital I/O Characteristics (VDD_PX=1.20 V (nominal))	60
Table 3-33: Digital I/O Characteristics (VDD_PX=1.80 V (nominal))	60
Table 3-34: Digital I/O Characteristics (VDD_PX=2.95 V (nominal) signals)	61
Table 3-35: Internal Device Frequencies	62
Table 3-36: Embedded Memory Details	63
Table 4-1: BAT_RTC Pin.	68
Table 4-2: BAT_RTC Charging Specifications	68
Table 4-3: POWER_ON_N Electrical Characteristics	69
Table 4-4: POWER_ON_N Timing Parameters	70
Table 4-5: USB Pin Descriptions.	71
Table 4-6: UART Pins	72
Table 4-7: UIM Interface Pins	73
Table 4-8: GPIO Pin Description	75
Table 4-9: SDIO Pin Descriptions	77
Table 4-10: I2C Interface Pins.	77
Table 4-11: VGPIO Reference Pin	78

Table 4-12: VGPIO Electrical Characteristics	78
Table 4-13: RESET_IN_N Pin.	79
Table 4-14: Reset Timing	79
Table 4-15: RESET_OUT_N Pin.	80
Table 4-16: ADC Interface Pins.	80
Table 4-17: ADC Interface Characteristics	80
Table 4-18: PCM/I2S Interface Signals	81
Table 4-19: PCM Interface Configurations	82
Table 4-20: PCM Mode Timing	82
Table 4-21: Master Transmitter With Data Rate = 3.072 MHz ($\pm 10\%$)	84
Table 4-22: SPI Pin Descriptions	85
Table 4-23: SPI Configuration.	85
Table 4-24: SPI Master Timing Characteristics.	86
Table 4-25: HSIC Pin Descriptions	86
Table 4-26: Clock Interface Pin Descriptions	87
Table 4-27: TP1 Pin Description	88
Table 4-28: Temperature Monitoring States	89
Table 4-29: Test Pin Descriptions	89
Table 4-30: Antenna Control Signals	90
Table 4-31: Tx Activity Indicator States.	91
Table 4-32: LED Interface Pin.	91
Table 4-33: UART1_RI Pin	92
Table 4-34: DR_SYNC Pin Details	93
Table 5-1: ESD Specifications ,.	99
Table 8-1: Standards Conformity	107
Table 8-2: Life Stress Test	107
Table 8-3: Environmental Resistance Stress Tests	108
Table 8-4: Corrosive Resistance Stress Tests	108
Table 8-5: Thermal Resistance Cycle Stress Tests	109
Table 8-6: Mechanical Resistance Stress Tests	110

Table 8-7: Handling Resistance Stress Tests	112
Table 9-1: WP7504 Antenna Gain Specifications	115
Table 9-2: Collocated Radio Transmitter Specifications	116
Table 10-1: Pin Definitions	119
Table 10-2: RF Pin Information	125
Table 10-3: Supply Pin Information	125
Table 10-4: Ground & Reserved Pin Information	125
Table 11-1: Customizable Features	126
Table 13-1: Acronyms and Definitions	128
Table 14-1: Test Settings—WP7502 UMTS Transmission Path	138
Table 14-2: Test Settings—WP7504 UMTS Transmission Path	138
Table 14-3: Test Settings—WP8548 UMTS Transmission Path	138
Table 14-4: Test Settings—WP7502 LTE Transmission Path	140
Table 14-5: Test Settings—WP7504 LTE Transmission Path	140
Table 14-6: Test Settings—WP7502 UMTS Receive Path.	142
Table 14-7: Test Settings—WP7504 UMTS Receive Path.	142
Table 14-8: Test Settings—WP8548 UMTS Receive Path.	143
Table 14-9: Test Settings—WP7502 LTE Receive Path	145
Table 14-10: Test Settings—WP7504 LTE Receive Path	145

>> 1: Introduction

This document defines the high-level product features and illustrates the interfaces for the AirPrime WP75xx/AirPrime WP8548 Smart Embedded Modules. It covers the hardware aspects of the product series, including electrical and mechanical.

The AirPrime WP7502 is an LTE, HSPA, WCDMA, and dual-band GSM/GPRS/EDGE embedded wireless module.

The AirPrime WP7504 is an LTE, HSPA, WCDMA, and CDMA embedded wireless module.

The AirPrime WP8548 is an HSPA, WCDMA, and quad-band GSM/GPRS/EDGE embedded wireless module.

1.1 General Features

The AirPrime WP75xx/AirPrime WP8548 is an industrial-grade LGA 239-pad module. Its wireless modem provides voice and data connectivity on the following networks:

- WP7502—LTE, HSPA, WCDMA, EDGE/GPRS
- WP7504—LTE, HSPA, WCDMA, CDMA
- WP8548—HSPA, WCDMA, EDGE/GPRS

Note: VoLTE is not supported.

GNSS functionality is also available:

- WP75xx—Available as a SKU-configuration
- WP8548—Standard feature

In addition to modem features, the AirPrime WP75xx/AirPrime WP8548 also embeds several cores for maximum flexibility and security for embedded software execution, including:

- A Telecom Core that natively manages 2G (WP7502/WP8548)/3G/4G (WP75xx) modem features
- An Application Core dedicated to customer applications, natively provided with Legato Application framework.

The following tables detail the bands/connectivity supported by the AirPrime WP7502, AirPrime WP7504, and AirPrime WP8548.

Table 1-1: WP7502 Supported Bands/Connectivity

Technology	RF band	Transmit band (Tx) (MHz)	Receive band (Rx) (MHz)	Notes
LTE	B1	1920–1980	2110–2170	MIMO support
	B3	1710–1785	1805–1880	
	B7	2500–2570	2620–2690	
	B8	880–915	925–960	
	B20	832–862	791–821	

Table 1-1: WP7502 Supported Bands/Connectivity (Continued)

Technology	RF band	Transmit band (Tx) (MHz)	Receive band (Rx) (MHz)	Notes
UMTS	B1	1920–1980	2110–2170	Diversity support
	B8	880–915	925–960	
GSM/GPRS/EDGE	E-GSM 900	880–915	925–960	
	DCS 1800	1710–1785	1805–1880	
GNSS ^a	GPS	-	1575.42 ± 1.023	
	GLONASS	-	1597.52–1605.92	
	Galileo	-	1575.42 ± 2.046	

a. GNSS support is SKU-dependent.

Table 1-2: WP7504 Supported Bands/Connectivity

Technology	RF band	Transmit band (Tx) (MHz)	Receive band (Rx) (MHz)	Notes
LTE	B2	1850–1910	1930–1990	MIMO support
	B4	1710–1755	2110–2155	
	B5	824–849	869–894	
	B12	699–716	729–746	
	B17	704–716	734–746	
	B25	1850–1915	1930–1995	
	B26	814–849	859–894	
UMTS	B2	1850–1910	1930–1990	Diversity support
	B4	1710–1755	2110–2155	
	B5	824–849	869–894	
CDMA EVDO Release A	BC0	824–849	869–894	Diversity support
	BC1	1850–1910	1930–1990	
	BC10	816–824	861–869	
GNSS ^a	GPS	-	1575.42 ± 1.023	
	GLONASS	-	1597.52–1605.92	
	Galileo	-	1575.42 ± 2.046	

a. GNSS support is SKU-dependent.

Table 1-3: WP8548 Supported Bands/Connectivity

Technology	RF band	Transmit band (Tx) (MHz)	Receive band (Rx) (MHz)	
UMTS	B1	1920–1980	2110–2170	
	B2	1850–1910	1930–1990	
	B5	824–849	869–894	
	B6	830–840	875–885	
	B8	880–915	925–960	
	B19	830–845	875–890	
GSM/GPRS/ EDGE	GSM 850	824–849	869–894	
	E-GSM 900	880–915	925–960	
	DCS 1800	1710–1785	1805–1880	
	PCS 1900	1850–1910	1930–1990	
GNSS	GPS	-	1575.42 ± 1.023	
	GLONASS	-	1597.52–1605.92	
	Galileo	-	1575.42 ± 2.046	

1.2 Interfaces

The AirPrime WP75xx/AirPrime WP8548 module provides the following interfaces and peripheral connectivity:

- Digital section running under 1.8V
- Dual UIM interfaces—See [UIM interface on page 72](#).
- VBAT_RF/VBAT_BB power supply—See [Power Supply Ratings on page 35](#).
- RF—See [RF on page 45](#).
- GNSS¹ (RF_GNSS)—See [GNSS on page 56](#).
- Real Time Clock battery backup—See [BAT_RTC on page 68](#).
- ON/OFF control:
 - POWER_ON_N—See [POWER_ON_N on page 69](#).
 - RESET_IN_N—See [Reset Signal \(RESET_IN_N\) on page 79](#).
- USB 2.0—See [USB on page 71](#).
- Two UART serial links—primary (8-line) and secondary (4-line)—See [UART on page 71](#).
- GPIOs—See [General Purpose Input/Output \(GPIO\) on page 74](#).
- SDIO—See [Secure Digital IO \(SDIO\) interface on page 76](#).
- I²C—See [I²C Interface on page 77](#).
- 1.8V voltage reference—See [VGPIO on page 78](#).
- Four ADCs—See [ADC on page 80](#).
- Digital audio (PCM/I²S)—See [Digital Audio on page 81](#).
- HSIC bus—See [HSIC Bus on page 86](#).
- Digital I/O

1. (WP75xx) GNSS support is SKU-dependent; (WP8548) Supported

- Antenna control—See [Antenna Control](#) on page 90.
- Two System Clock outputs—See [Clock](#) on page 87.
- Test pins—See [Test Pins](#) on page 89.
- Tx Activity Indicator (TX_ON)—See [Tx Activity Indicator \(TX_ON\)](#) on page 91.

1.3 Common Flexible Form Factor (CF3)

The AirPrime WP75xx/AirPrime WP8548 belongs to the Common Flexible Form Factor (CF3) family of modules. This family consists of a series of WWAN modules that share the same mechanical dimensions (same width and length with varying thicknesses) and footprint. The CF3 form factor provides a unique solution to a series of problems faced commonly in the WWAN module space as it:

- Accommodates multiple radio technologies (from GSM to LTE advanced) and band groupings
- Supports bit-pipe (Essential Module Series) and value-add (Smart Module Series) solutions
- Offers electrical and functional compatibility

1.4 Physical Dimensions and Connection Interface

The AirPrime WP75xx/AirPrime WP8548 module is a compact, robust, fully shielded and labeled module with the dimensions noted in [Table 1-4](#).

Table 1-4: AirPrime WP75xx/AirPrime WP8548 Dimensions^a

Parameter	Nominal	Tolerance	Units
Length	23.00	±0.10	mm
Width	22.00	±0.10	mm
Thickness	4.352	±0.203	mm
Weight (with label)	4.2	±0.1	g

a. Dimensions are accurate as of the release date of this document.

The AirPrime WP75xx/AirPrime WP8548 module is an LGA form factor device. All electrical and mechanical connections are made through the 239 Land Grid Array (LGA) pads on the bottom side of the PCB. (See [Figure 10-1 on page 118](#) for details.)

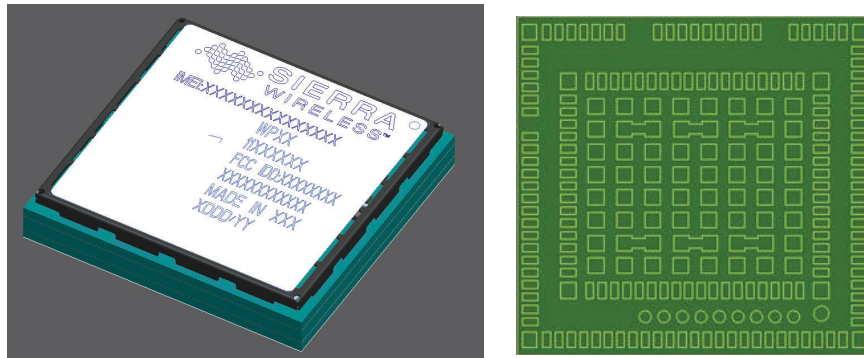


Figure 1-1: AirPrime WP75xx/AirPrime WP8548 Mechanical Overview

The 239 pads have the following distribution:

- 157 signal pads, 1.0x0.5 mm, 0.8 mm pitch
 - 66 inner signal pads
 - 91 outer signal pads
- 10 test points:
 - 1 polarity mark (Ground), 1.0 mm diameter
 - 9 test points, 0.8 mm diameter, 1.20 mm pitch
- 72 ground pads:
 - 64 inner ground pads, 1.0x1.0 mm, pitch 1.83 mm/1.48 mm
 - 4 inner corner ground pads, 1.0x1.0 mm
 - 4 outer corner ground pads, 1.0x0.9 mm

>> 2: Functional Specifications

2.1 Architecture

The following figures present overviews of the AirPrime WP75xx/AirPrime WP8548 modules' internal architecture and external interfaces.

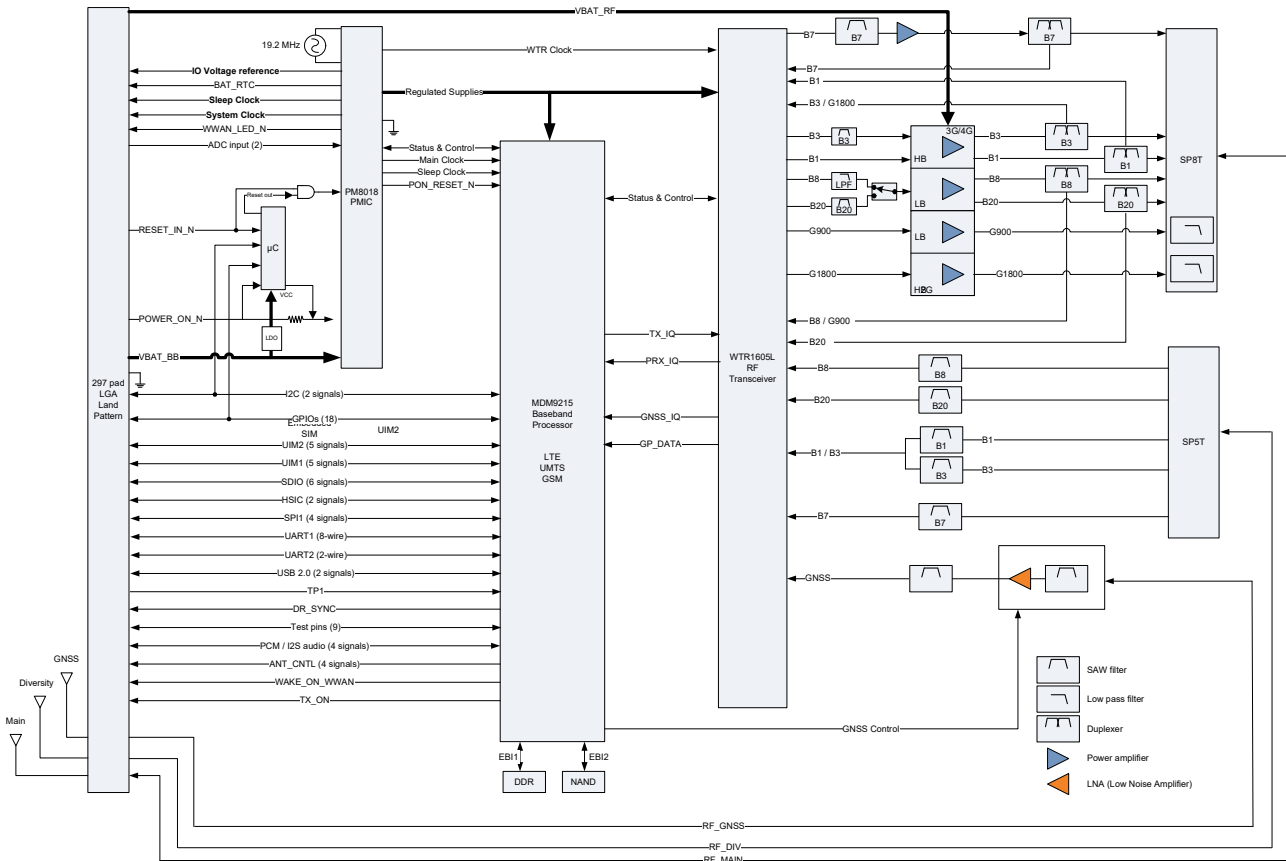


Figure 2-1: AirPrime WP7502 Architecture Overview

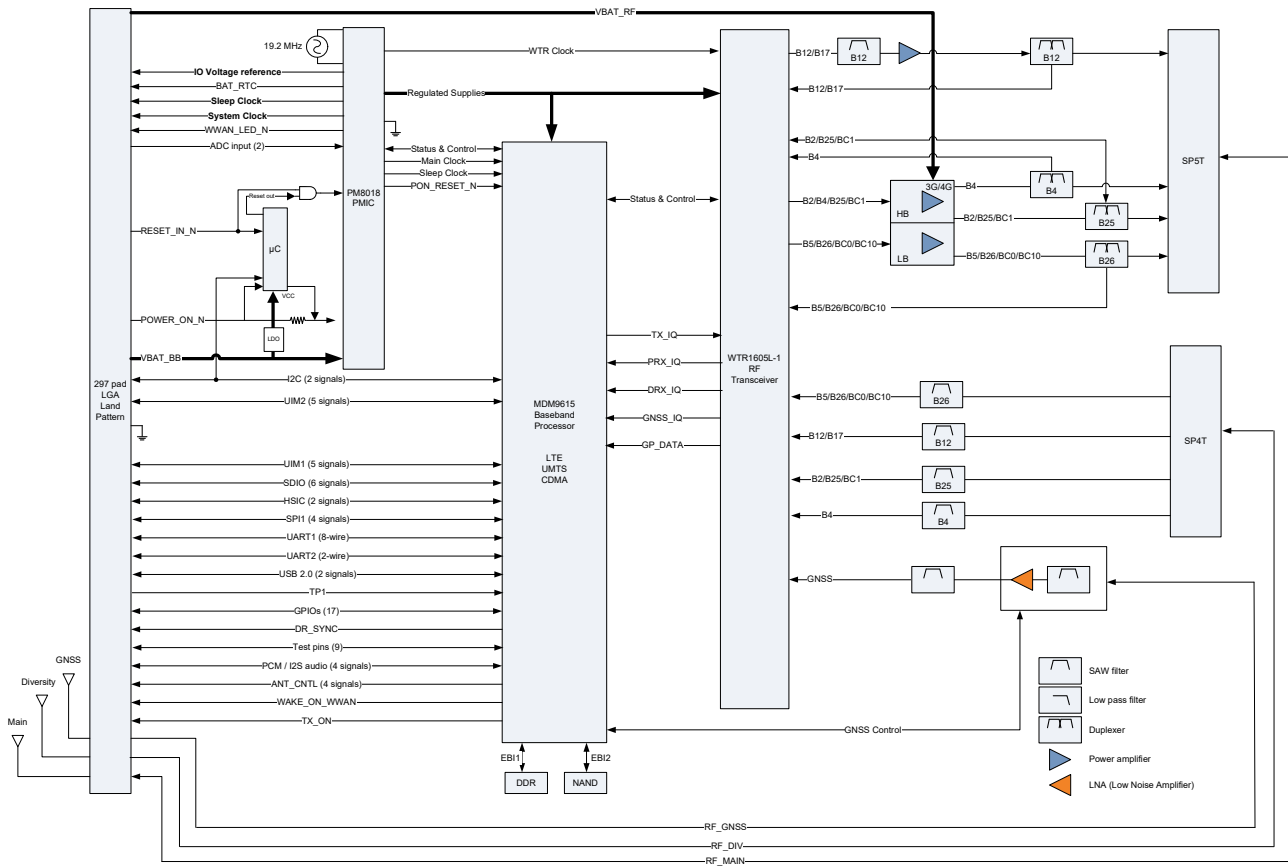


Figure 2-2: AirPrime WP7504 Architecture Overview

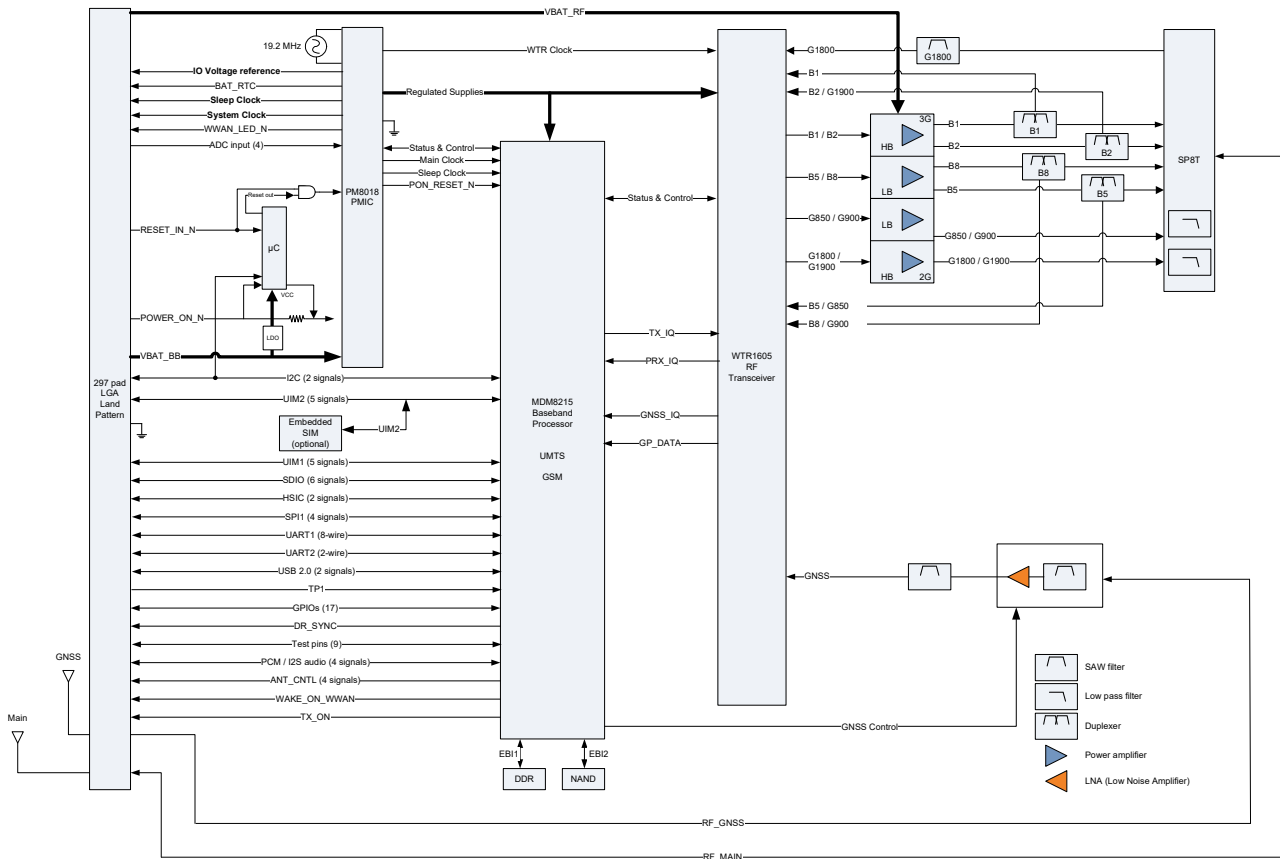


Figure 2-3: AirPrime WP8548 Architecture Overview

2.1.1 Chipsets

The AirPrime WP75xx/AirPrime WP8548 modules are based on the following QUALCOMM baseband processors:

- MDM8215—AirPrime WP8548
- MDM9215—AirPrime WP7502
- MDM9615—AirPrime WP7504

2.2 Telecom Features

Table 2-1 summarizes the AirPrime WP75xx/AirPrime WP8548 module’s capabilities offered through the Telecom core.

Table 2-1: AirPrime WP75xx/AirPrime WP8548 Capabilities

Feature	Description
Electrical	3.4–4.3V supply voltage (VBAT_BB, VBAT_RF): <ul style="list-style-type: none"> • Single supply (recommended), VBAT_BB tied to VBAT_RF <i>or</i> • Dual supplies, single supply each for VBAT_BB and VBAT_RF
Voice (Digital Audio)	<ul style="list-style-type: none"> • PCM/I²S digital audio interface • Supports Enhanced Full Rate (EFR), Full Rate (FR), Half Rate (HR), and both Narrow-Band and Wide-band Adaptive Multirate (AMR-NB and AMR-WB) vocoders • MO and MT calling • Echo cancellation and noise reduction • Emergency calls (112, 110, 911, etc.) • Incoming call notification • DTMF generation • Internal codec driver for WM8944
SMS	<ul style="list-style-type: none"> • SMS MO and MT • CS and PS support • SMS saving to UIM card or ME storage • SMS reading from UIM card or ME storage • SMS sorting • SMS concatenation • SMS Status Report • SMS replacement support • SMS storing rules (support of AT+CNMI, AT+CNMA)
Supplementary services	<ul style="list-style-type: none"> • Call Barring • Call Forwarding • Call Hold • Caller ID • Call Waiting • Multi-party service • USSD • Automatic answer

Table 2-2: WP7502 RF Bands/Connectivity

Technology	RF band	Transmit band (Tx) (MHz)	Receive band (Rx) (MHz)	Maximum output power
LTE	B1	1920–1980	2110–2170	23 dBm ± 1 dBm; Class 3bis
	B3	1710–1785	1805–1880	23 dBm ± 1 dBm; Class 3bis
	B7	2500–2570	2620–2690	22 dBm ± 1 dBm; Class 3bis
	B8	880–915	925–960	23 dBm ± 1 dBm; Class 3bis
	B20	832–862	791–821	23 dBm ± 1 dBm; Class 3bis
UMTS	B1	1920–1980	2110–2170	23 dBm ± 1 dBm; Class 3bis
	B8	880–915	925–960	23 dBm ± 1 dBm; Class 3bis
GSM/GPRS/ EDGE	E-GSM 900	880–915	925–960	2 Watts GSM/GPRS/EDGE
	DCS 1800	1710–1785	1805–1880	1 Watt GSM/GPRS/EDGE
GNSS ^a	GPS	-	1575.42 ± 1.023	-
	GLONASS	-	1597.52–1605.92	-
	Galileo	-	1575.42 ± 2.046	-

a. GNSS support is SKU-dependent.

Table 2-3: WP7504 RF Bands/Connectivity

Technology	RF band	Transmit band (Tx) (MHz)	Receive band (Rx) (MHz)	Maximum output power
LTE	B2	1850–1910	1930–1990	23 dBm ± 1 dBm; Class 3bis
	B4	1710–1755	2110–2155	23 dBm ± 1 dBm; Class 3bis
	B5	824–849	869–894	23 dBm ± 1 dBm; Class 3bis
	B12	699–716	729–746	23 dBm ± 1 dBm; Class 3bis
	B17	704–716	734–746	23 dBm ± 1 dBm; Class 3bis
	B25	1850–1915	1930–1995	23 dBm ± 1 dBm; Class 3bis
	B26	814–849	859–894	23 dBm ± 1 dBm; Class 3bis
UMTS	B2	1850–1910	1930–1990	23 dBm ± 2 dBm; Class 3bis
	B4	1710–1755	2110–2155	23 dBm ± 1 dBm; Class 3bis
	B5	824–849	869–894	23 dBm ± 1 dBm; Class 3bis
CDMA	BC0	824–849	869–894	23 dBm ± 1 dBm; Class 3bis
	BC1	1850–1910	1930–1990	23 dBm ± 1 dBm; Class 3bis
	BC10	816–824	861–869	23 dBm ± 1 dBm; Class 3bis

Table 2-3: WP7504 RF Bands/Connectivity (Continued)

Technology	RF band	Transmit band (Tx) (MHz)	Receive band (Rx) (MHz)	Maximum output power
GNSS ^a	GPS	-	1575.42 ± 1.023	-
	GLONASS	-	1597.52–1605.92	-
	Galileo	-	1575.42 ± 2.046	-

a. GNSS support is SKU-dependent.

Table 2-4: WP8548 RF Bands/Connectivity

Technology	RF band	Transmit band (Tx) (MHz)	Receive band (Rx) (MHz)	Maximum output power
UMTS	B1	1920–1980	2110–2170	23 dBm ± 1 dBm; Class 3bis
	B2	1850–1910	1930–1990	23 dBm ± 1 dBm; Class 3bis
	B5	824–849	869–894	23 dBm ± 1 dBm; Class 3bis
	B6	830–840	875–885	23 dBm ± 1 dBm; Class 3bis
	B8	880–915	925–960	23 dBm ± 1 dBm; Class 3bis
	B19	830–845	875–890	23 dBm ± 1 dBm; Class 3bis
GSM/GPRS/EDGE	GSM 850	824–849	869–894	2 Watts GSM/GPRS/EDGE
	E-GSM 900	880–915	925–960	2 Watts GSM/GPRS/EDGE
	DCS 1800	1710–1785	1805–1880	1 Watt GSM/GPRS/EDGE
	PCS 1900	1850–1910	1930–1990	1 Watt GSM/GPRS/EDGE
GNSS	GPS	-	1575.42 ± 1.023	-
	GLONASS	-	1597.52–1605.92	-
	Galileo	-	1575.42 ± 2.046	-

2.2.1 Network Technology Specifications

2.2.1.1 GSM/GPRS/EDGE Specifications

The following table describes GSM/GPRS/EDGE specifications for WP7502 and WP8548 modules.

Table 2-5: Supported GSM/GPRS/EDGE Specifications^a

Standard	Feature Description
GPRS	Packet-switched data: <ul style="list-style-type: none"> • DTM (simple class A) operation • GPRS Multislot class 10 (no backoff)—Four Rx slots (maximum), two Tx slots (maximum), five active slots total • Coding schemes—CS1–CS4 • GEA1, GEA2, and GEA3 ciphering • WCDMA/GERAN system selection
EDGE	<ul style="list-style-type: none"> • E2 power class for 8 PSK • DTM (simple class A), multislot class 12 • EGPRS—Multislot class 12 (with backoff)—Four Rx slots (maximum), four Tx slots (maximum), five active slots total • Coding schemes—MCS1–MCS9 • BEP reporting • SRB loopback and test modes A and B • 8-bit and 11-bit RACH • PBCCH support • One-phase/two-phase access procedures • Link adaptation and IR • NACC, extended UL TBF • PFC/PFI (Packet Flow Context/Packet Flow Identifier) support - allows identity tagging of RLC blocks to identify separate QoS streams at the radio link layer • GPRS/EDGE MSC12-EDA - permits allocation of more than two uplink timeslots for GPRS/EDGE • Enh DL RLC/MAC Segmentation - permits reception of MAC control messages that exceed one radio block capacity in length • Enhanced Ext UL TBF - dummy block transmission is punctured for current saving purposes • 2G PS handover - packet-switched equivalent of CS handover to ensure faster cell change and improved throughput • WCDMA/GERAN <ul style="list-style-type: none"> • Band Scan: Run-time Configurable RRC Band Scan Order • Power and Network Optimizations: Frame Early Termination for Power Optimization • Protocols: MRAB-Pack-1 Enhancements - reduces multi-RAB call drops

a. WP7502/WP8548 only

2.2.1.2 WCDMA Specifications

The following table describes WCDMA specifications for WP75xx/WP8548 modules.

Table 2-6: Supported WCDMA Specifications

Standard	Feature Description
R99	<ul style="list-style-type: none"> • All modes and data rates for WCDMA FDD, with the following restrictions: <ul style="list-style-type: none"> • The downlink supports the following specifications: <ul style="list-style-type: none"> • Up to four physical channels, including the broadcast channel (BCH), if present • Up to three dedicated physical channels (DPCHs) • Spreading factor (SF) range support from 4 to 256 • The uplink supports the following specifications: <ul style="list-style-type: none"> • One physical channel, eight TrCH, and 16 TrBks starting at any frame boundary • A maximum data rate of 384 kbps • Full SF range support from 4 to 256 • PS data rates of 384 kbps DL and 384 kbps UL
R5 HSDPA	<ul style="list-style-type: none"> • PS data speeds up to 42 Mbps (UE category 24) on the downlink • HS-DSCH (HS-SCCH, HS-PDSCH, and HS-DPCCH) • Maximum of 15 HS-PDSCH channels, both QPSK and 16 QAM modulation • Support for 3GPP-defined features: <ul style="list-style-type: none"> • R99 transport channels • Maximum of four simultaneous HS-SCCH channels • CQI and ACK/NACK on HS-DPCCH channel • All incremental redundancy versions for HARQ • Configurable support for power classes 3 or 4, per TS 25.101 • TFC selection limitation on UL factoring in transmissions on the HS-DPCCH, per TS 25.133 • Switching between HS-PDSCH and DPCH channel resources, as directed by the network • Network activation of compressed mode by SF/2 or HLS on the DPCH for conducting inter-frequency or inter-radio access technology (RAT) measurements when the HS-DSCH is active • STTD on both associated DPCH and HS-DSCH simultaneously • CLTD mode 1 on the DPCH when the HS-PDSCH is active • STTD on HS-SCCH when STTD or CLTD mode 1 are configured on the associated DPCH • SCH-IC support • HS-DSCH DRX support

Table 2-6: Supported WCDMA Specifications (Continued)

Standard	Feature Description
R6 HSUPA	<ul style="list-style-type: none"> • E-DCH data rates of up to 5.76 Mbps for 2 ms TTI (UE category 6) uplink • Support for 3GPP-defined features: <ul style="list-style-type: none"> • E-AGCH, E-RGCH, and E-HICH channels for downlink; E-RGCH and E-HICH supports serving and non-serving radio links, with up to four radio links in the E-DCH active set • All HARQ incremental redundancy versions and maximum number of HARQ retransmissions • Uplink E-DCH channel with support for up to four E-DPDCH channels • HSUPA channels run simultaneously with R99 and HSDPA channels • STTD on all HSUPA downlink channels • CLTD mode 1 on HS-PDSCH and DPCH along with HSUPA channels • Switch between HSUPA channels and DPCH channel resources, as directed by the network • Handover using compressed mode with simultaneous E-DCH and HS-DSCH interactive, background, and streaming QoS classes • DPCCH DTX support

2.2.1.3 LTE Specifications

The following table describes LTE specifications for WP75xx modules.

Table 2-7: Supported LTE Specifications^a

Standard	Feature Description
R9 Cat 3 FDD	<ul style="list-style-type: none"> • Release 9 mandatory LTE features • FDD: up to 100 Mbps downlink, 50 Mbps uplink • 1.4 MHz, 3 MHz, 5 MHz, 10 MHz, 15 MHz and 20 MHz RF bandwidth • IPv6, QoS • Inter-RAT capabilities with HSPA+, CDMA (WP7504 only), EDGE (WP7502 only) and applicable backward-compatible modes • NAS & RRC standalone security • Commercial Mobile Alert System (CMAS) • ETWS (Earthquake Tsunami Warning System) notification • Inter-frequency/bandwidth mobility • DRX cycle while in: <ul style="list-style-type: none"> • Connected mode • Idle mode • UE IRAT support for Self Organizing Networks and Automatic Neighbor Relation (SON AR) • Mode reselections: <ul style="list-style-type: none"> • eHRPD to LTE in idle mode based on LTE neighbor cell measurements • LTE in idle mode to eHRPD idle • LTE <-> GERAN Idle mode mobility (cell reselection) • LTE <-> UMTS Idle mode mobility (cell reselection) • Mode redirections: <ul style="list-style-type: none"> • LTE in connected mode to eHRPD idle <ul style="list-style-type: none"> • Blind redirection • Based on measurement gaps • UMTS to LTE redirections <ul style="list-style-type: none"> • Blind redirection • Based on measurements during WCDMA compressed mode gaps • GERAN to LTE redirections (blind; no measurements) • LTE to UMTS redirections (with measurements on UMTS) • LTE to UMTS PS Handover • LTE/GW Data Silent Redial for Inter-RAT • Attach/detach PS during Voice Call or SMS

Table 2-7: Supported LTE Specifications^a (Continued)

Standard	Feature Description
System Determination	<ul style="list-style-type: none"> • Frequency Scan and System Selection within LTE • LTE BPLMN support • LTE Connected mode OOS • System selection across RATs, Standalone Security, Dedicated EPS Bearer Management and Dormancy • System selection across LTE, UMTS, GERAN • 256 UPLMN and 256 OPLMN entries in UIM support • Carrier Specific BSR Requirements • Data Services: eHRPD/LTE - Data System Determination for Multiple Radio Systems • Multimode system selection - facilitates system selection and avoids unnecessary attach requests in a 3GPP+3GPP2 multimode UE
Data	<ul style="list-style-type: none"> • Data call throttling • Default IPv4 bearer activation at attach/IPv4 data call • NW and UE initiated QoS • Dual IP and IPv4/IPv6 continuity • IPv4/IPv6 session continuity • W/G IP session continuity • Emergency services - LTE NAS Support for Control Plane LTE Positioning Protocol • Data services - LTE-eHRPD Mobility Support of APN Class and APN Bearer in Application Profile over LTE

a. WP75xx only

2.2.1.4 CDMA Specifications

The following table describes CDMA specifications for WP7504 modules.

Table 2-8: Supported CDMA Specifications^a

Standard	Feature Description
CDMA IS-2000	<ul style="list-style-type: none"> • Up to 153 kbps, simultaneous forward and reverse channel
CDMA IS-856 (1xEV-DO Release A)	<ul style="list-style-type: none"> • Up to 3.1 Mbps forward channel • Up to 1.8 Mbps reverse channel

a. WP7504 only

2.2.2 Modem Specifications

Table 2-9: Supported Modem Specifications^a

Standard	Feature Description
Data	<ul style="list-style-type: none"> • IPHC protocol as RFC 2509 • Stateless DHCPv4 protocol to get P-CSCF and DNS addresses • IPv4/IPv6 • 4 PDNs Support over Multi-RmNet • Dual IP on single RmNet • IP only Mode/Raw IP Mode • Multi-RmNet Data Call

a. Preliminary

2.3 Multi-Core Processing Capabilities

The AirPrime WP75xx/AirPrime WP8548 is a powerful multiple-core system that includes:

- One QDSP6 core, embedding Telecom firmware with integrated cellular voice (future firmware release), data and wireless Internet connectivity
- One Cortex-A5 core entirely dedicated to customer application and natively provided with Linux operating system

>> 3: Technical Specifications

3.1 Environmental

The environmental specifications for operation and storage of the AirPrime WP75xx/AirPrime WP8548 are defined in Table 3-1.

Table 3-1: Environmental Specifications

Parameter	Range	Operating Class
Ambient Operating Temperature	-30°C to +70°C	Class A
	-40°C to +85°C	Class B
Ambient Storage Temperature	-40°C to +85°C	-
Ambient Humidity	95% or less	-

Class A is defined as the operating temperature range within which the device:

- Shall exhibit normal function during and after environmental exposure.
- Shall meet the minimum requirements of 3GPP or appropriate wireless standards.

Class B is defined as the operating temperature range within which the device:

- Shall remain fully functional during and after environmental exposure
- Shall exhibit the ability to establish any of the device's supported call modes (SMS, Data, and emergency calls) at all times even when one or more environmental constraint exceeds the specified tolerance.
- Unless otherwise stated, full performance should return to normal after the excessive constraint(s) have been removed.

3.2 Power Supply Ratings

The AirPrime WP75xx/AirPrime WP8548 operates using DC power supplied via the VBAT_RF and VBAT_BB signals. Power supply options are:

- (Recommended) A single regulated DC power supply (3.7V nominal)
- Two regulated DC power supplies (3.7V nominal), one each for VBAT_BB and VBAT_RF

Note: Operation above the maximum specified operating voltage (see [Table 3-4 on page 36](#)) is not recommended, and specified typical performance or functional operation of the device is neither implied nor guaranteed.

Note: The AirPrime WP75xx/AirPrime WP8548 does not support operation using USB_VBUS power.

Table 3-2: Absolute Maximum Ratings

Parameter	Module	Min	Max	Units
Power supply voltage (VBAT_BB/VBAT_RF)	WP7502	-0.3	+4.6	V
	WP7504	-0.3	+5.5	V
	WP8548	-0.3	+6.0	V

Table 3-3: Power Supply Pins

Pin	Name	Direction	Function	Notes
63, 158	VBAT_BB	Input	Baseband power supply	63—Must be used 158—Optional
61, 62, 157	VBAT_RF	Input	RF power supply	61/62—Must be used 157—Optional

Table 3-4: Operating Conditions

Parameter		Min	Typ	Max	Units	Notes
Power supply voltage ^a		3.4	3.7	4.3	V	Must be within min/max values over all operating conditions (including voltage ripple, droop, and transient), especially (for the WP7502 and WP8548) during the GSM transmit burst.
Power supply ripple		-	-	100	mV _{pp}	See Figure 3-1 on page 37 .
Power supply voltage droop		-	-	250	mV	See Figure 3-1 on page 37 and Under-Voltage Lockout (UVLO) on page 37 .
Power supply voltage transient (overshoot/undershoot)		-	-	300	mV	See Figure 3-1 on page 37 .
Supply current	LTE, UMTS, CDMA	-	0.8	1.5	A	<ul style="list-style-type: none"> Typical value varies and depends on output power, band, and operating voltage. See Current Consumption on page 41 for values measured under normal operating conditions. Max value measured over 100 μs period.
	GSM	-	1.0	3.0	A	

a. Power supply voltage outside the required range may affect call quality (dropped calls, data transfer errors, etc.).

Customer should characterize the ripple, droop, and transient response (overshoot/undershoot) of the power supply delivery system at the module input under full GSM transmit power. To minimize voltage variation, add suitable capacitors to the supply line as close as possible to the module—depending on the power supply design, these capacitors may range from tens to several thousand μF.

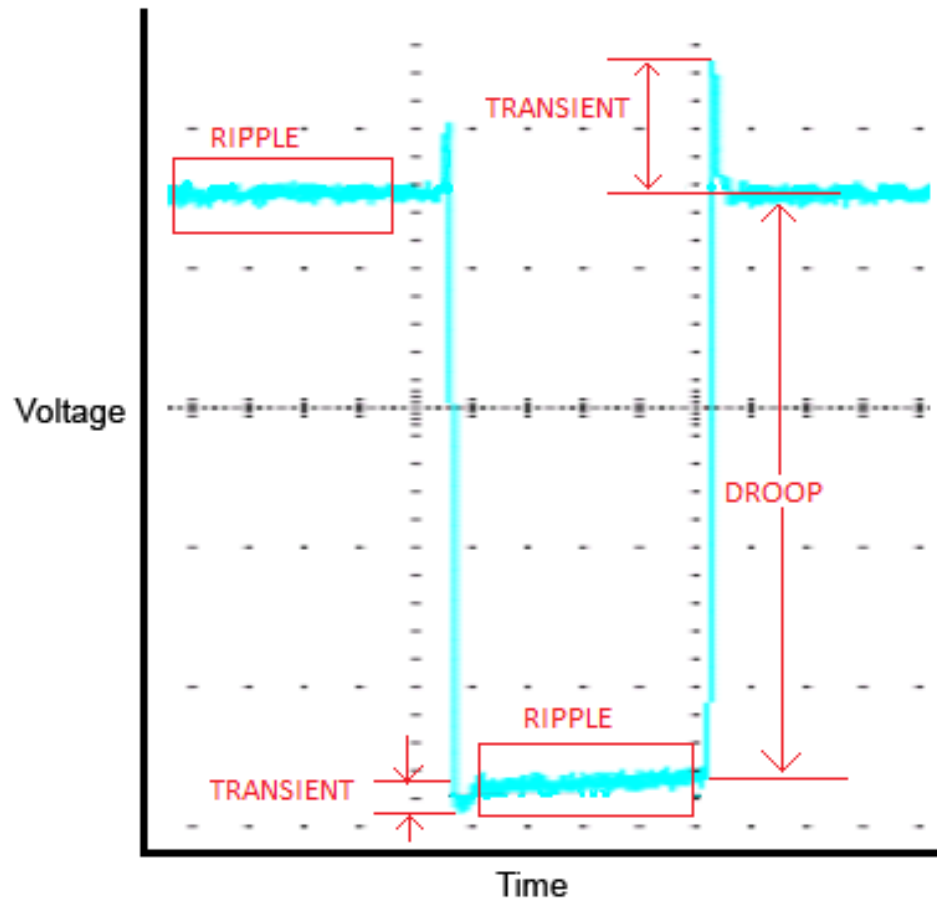


Figure 3-1: Power Supply Characteristics (capture enlarged)

3.2.1 Under-Voltage Lockout (UVLO)

The power management section of the AirPrime WP75xx/AirPrime WP8548 includes an under-voltage lockout circuit that monitors supply and shuts down when VBAT_BB/ VBAT_RF falls below the threshold.

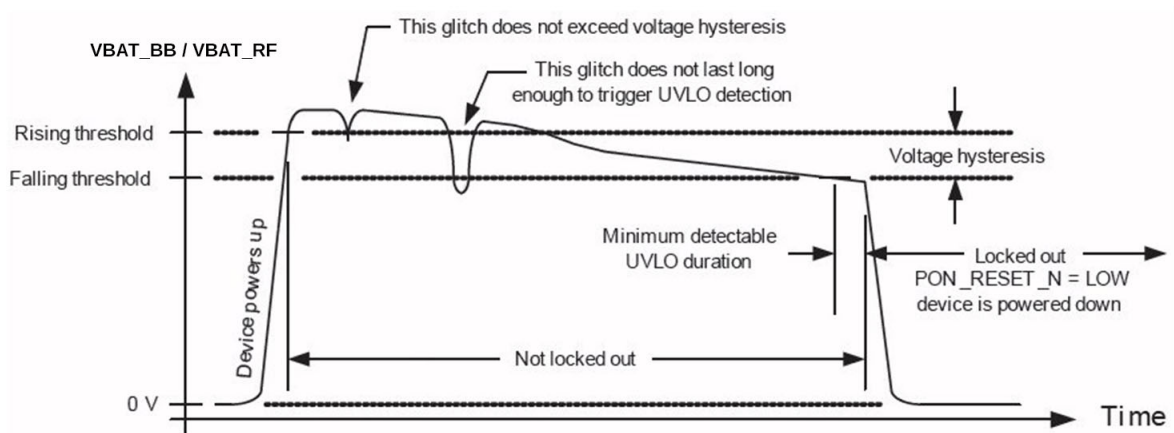


Figure 3-2: Under-Voltage Lockout (UVLO) Diagram

The AirPrime WP75xx/AirPrime WP8548 will power down and remain off until the level of VBAT_BB/VBAT_RF returns to the valid range and the ON/OFF signal is active.

Note: If the device experiences six consecutive UVLO events less than 45 seconds apart (approximately) and a host-initiated power down or reset has not occurred, the device enters a mode in which only the DM port enumerates on the USB.

Table 3-5: UVLO Specifications

Parameter	Min	Typ	Max	Units	Notes
Threshold voltage, falling	1.500	2.550	3.050	V	Programmable value
Threshold voltage, accuracy	-5	-	+5	%	
Hysteresis	100	175	250	mV	
UVLO detection interval	-	1.0	-	μs	

3.2.2 Power Consumption States

The AirPrime WP75xx/AirPrime WP8548 has three basic power states (Active, Ultra Low Power Mode, and Off). As the module transitions between power states, the range of available device functionality adjusts appropriately, as described in [Table 3-6 on page 39](#) and [Figure 3-3 on page 40](#).

Table 3-6: Supported Power States

State	Description
Active	<p>Module is fully powered and operating in one of the following modes:</p> <ul style="list-style-type: none"> • Full function (WWAN radio active; GNSS radio can be turned on/off)—Highest power consumption. • Idle (Module registered on network, but no active connection; GNSS radio can be turned on/off) • Airplane mode (WWAN radio off; GNSS radio can be active if allowed by PRI) • USB-SS mode—Lowest power consumption while module is in Active state. When the module is in this mode, the processor monitors certain signals (triggers) that can ‘wake’ the module—see Wakeup Interrupt (USB-SS Mode) on page 76 for details. <p>Note: On Windows systems, due to limitations of the Windows ECM driver, USB-SS mode is only supported if ECM is disabled or USB is disconnected.</p> <p>While in the Active state, the module actively reduces power consumption by disabling components that are not in use (for example, stepping down clock signals, putting the USB into ‘selective suspend’, etc.). If the device needs to be in use infrequently and greater current consumption savings are needed, the module can be configured to enter Ultra Low Power Mode. See Active State to ULPM Transition on page 41 for details.</p>
Ultra Low Power Mode (ULPM)	<p>Module is in its lowest power state monitoring configured triggers that will return the module to the Active state.</p> <ul style="list-style-type: none"> • For details on how ULPM is configured and entered, see Active State to ULPM Transition on page 41. • The module remains in ULPM until any of the following occur: <ul style="list-style-type: none"> • A configured trigger occurs. (See Wakeup Events (ULPM) on page 76 for details.) • POWER_ON_N is asserted (transitioned from OFF to ON) • RESET_IN_N is used to reset the module with POWER_ON_N on. (Note: If RESET_IN_N is used in ULPM when POWER_ON_N is off, all configured wakeup triggers are cleared, leaving only POWER_ON_N as a signal to exit ULPM mode.) • ULPM current consumption varies depending on which triggers are configured. For example, the lowest consumption occurs when the processor is waiting only for a timer (approximately 6 μA), and the highest consumption occurs when all supported triggers are configured. <p>Important: All interfaces connected to the module’s GPIOs (except GPIO34–GPIO41) must be tri-stated or off to prevent additional leakage current during ULPM and potentially damaging the unit by applying a voltage when the GPIOs are off. Only GPIO34–GPIO41 can safely be used. See Table 4-8 on page 75 for a listing of the module’s GPIOs.</p>
OFF	<p>Module is OFF (no power to the system).</p> <p>Apply power with POWER_ON_N asserted for the system to go to Active state.</p>

[Figure 3-3 on page 40](#) illustrates the current consumption requirements of the different power states and the possible transitions between power states. For specific values, see [Table 3-7 on page 41](#), [Table 3-8 on page 42](#), and [Table 3-9 on page 44](#).

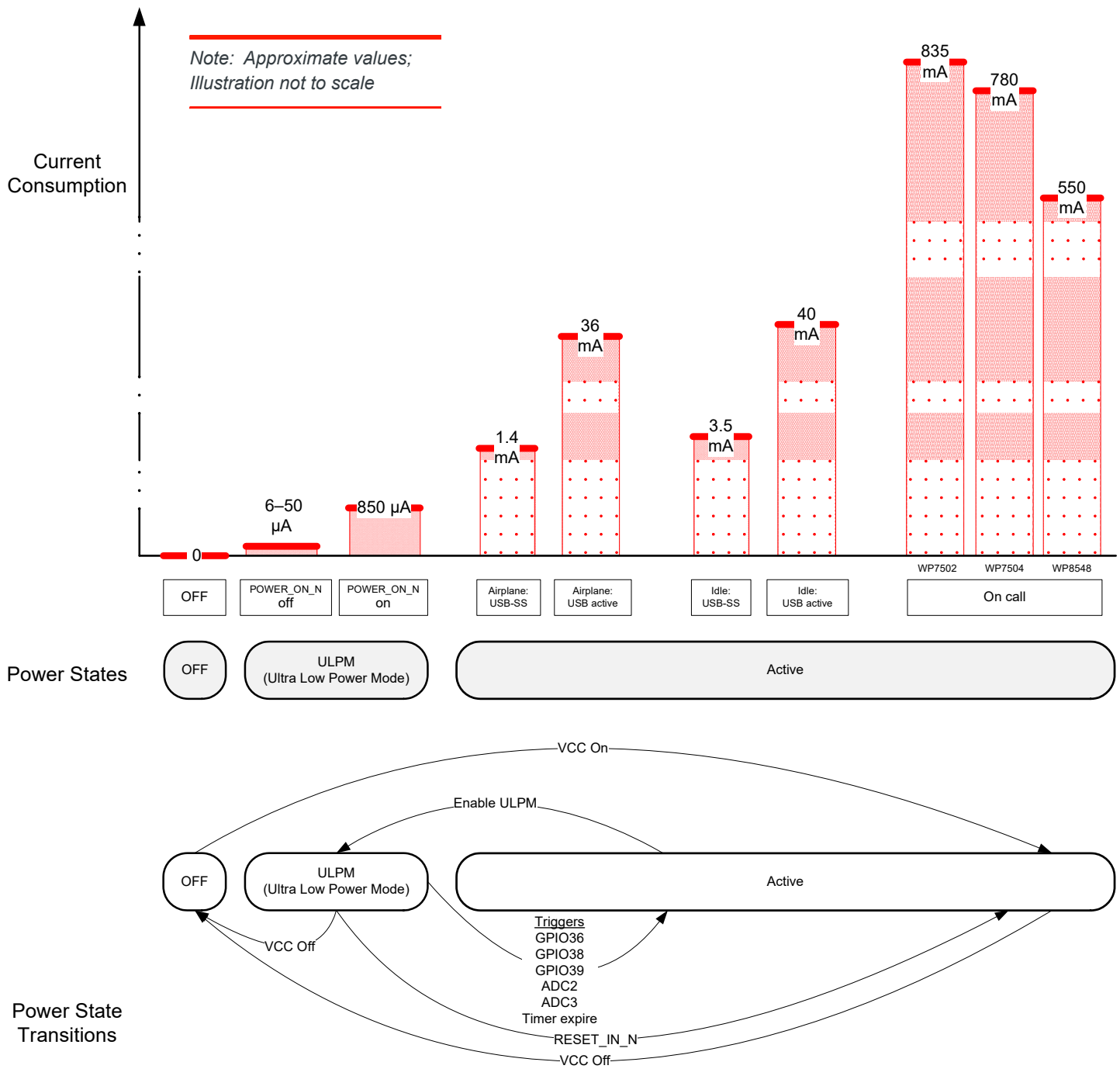


Figure 3-3: Power State Transitions

3.2.3 Active State to ULPM Transition

If the module will be used in situations where it needs to be active very infrequently (for example, in a remote monitoring station that must transmit data once a day), it can be placed in Ultra Low Power Mode (ULPM) via sysfs/Legato to achieve significantly lower power consumption than is possible in USB-SS mode (low power active state):

1. Configure one or more supported wakeup triggers that the processor will monitor when the module is in ULPM. Supported triggers include:
 - Interrupt-capable GPIOs (GPIO36, GPIO38, GPIO39)—Trigger on level (high/low) or edge (rising/falling/both)
 - Timer — Trigger after a specified period. (1–4294967 seconds; 0=timer disabled)
 - ADCs (ADC2, ADC3)—Trigger on threshold (above/below; e.g. wake on ADCx above 1.2V) or range (inside/outside; e.g. wake when value is inside a specified range, or outside a specified range)
2. Initiate ULPM. If the configured wakeup conditions are still valid (they have not triggered yet), the module will enter ULPM, otherwise the request will fail and will need to be repeated.

Note: These triggers are non-persistent — if the module enters ULPM and then returns to Active power state, the triggers are erased and will need to be reconfigured.

3.2.4 Current Consumption

The following tables describe the WP7502, WP7504, and WP8548 modules' current consumption under various power states. Typical values are measured at nominal supply voltage, nominal ambient temperature, and with a conducted 50Ω load on the antenna port.

Table 3-7: WP7502 Current Consumption Values

Mode	Parameter	Min	Typ ^a	Max ^b	Units
Power state—Active					
On Call—GSM ^c	900 MHz PCL5 +32 dBm	-	380 ^d	930 ^e	mA
	1800 MHz PCL0 +29 dBm	-	250 ^d	540 ^e	mA
GSM Peak current ^c	900 MHz PCL5	-	-	2.5 ^e	A
	1800 MHz PCL0	-	-	1.5 ^e	A
HSDPA Data transfer ^f	Band 1	-	690	745	mA
	Band 8	-	600	670	mA

Table 3-7: WP7502 Current Consumption Values (Continued)

Mode	Parameter	Min	Typ ^a	Max ^b	Units	
LTE Data transfer ^g	B1	-	835	950	mA	
	B3	-	755	925	mA	
	B7	-	720	870	mA	
	B8	-	760	850	mA	
	B20	-	695	800	mA	
Idle—GSM	<ul style="list-style-type: none"> Registered MFRMS=5 	USB active	36	39	40	mA
		USB-SS ^h	1.2	2.5	4.5	mA
Idle—WCDMA	<ul style="list-style-type: none"> Registered DRX=8 	USB active	37	38	39	mA
		USB-SS ^h	1.2	1.8	2.5	mA
Idle—LTE	<ul style="list-style-type: none"> Registered Paging cycle=256 	USB active	36	39	41	mA
		USB-SS ^h	2.7	2.9	3.7	mA
Airplane mode	Radio off	USB active	34	36	40	mA
		USB-SS ^h	1.2	1.4	1.6	mA
Power state—Ultra Low Power mode (ULPM)						
See Table 3-10 on page 45 for details.						
GNSS ⁱ						
GNSS	Acquisition (Airplane mode, cold start)	30	40	50	mA	
	Tracking (Registered)	25	35	45	mA	

- a. Typical, measured at nominal temperature, nominal voltage.
- b. Worst case, measured over extreme temperature and voltage.
- c. At GSM conducted max Tx output power (see [Table 3-12 on page 46](#))
- d. Typical—values for one slot
- e. Maximum—values for four slots with no backoff
- f. At WCDMA conducted max Tx output power (see [Table 3-15 on page 48](#))
- g. At LTE conducted max Tx output power (see [Table 3-21 on page 50](#))
- h. On Windows systems, due to limitations of the Windows ECM driver, USB-SS mode is only supported if ECM is disabled or USB is disconnected.
- i. GNSS current consumption values are for the GNSS radio only. For total consumption, add the GNSS value to the consumption for the mode being used.

Table 3-8: WP7504 Current Consumption Values

Mode	Parameter	Min	Typ ^a	Max ^b	Units
Power state—Active					
On Call—CDMA ^c	BC0	-	530	675	mA
	BC1	-	670	900	mA
	BC10	-	535	600	mA

Table 3-8: WP7504 Current Consumption Values (Continued)

Mode	Parameter	Min	Typ ^a	Max ^b	Units	
EV-DO ^c	BC0	-	500	675	mA	
	BC1	-	635	900	mA	
HSDPA data transfer ^d	Band 2	-	675	825	mA	
	Band 4	-	585	650	mA	
	Band 5	-	535	625	mA	
LTE Data transfer ^e	B2	-	780	975	mA	
	B4	-	645	825	mA	
	B5	-	595	800	mA	
	B12	-	650	800	mA	
	B17	-	665	800	mA	
	B25	-	775	975	mA	
Idle—CDMA	<ul style="list-style-type: none"> Registered QPCH=5.12 s 	USB active	36	40	46	mA
		USB-SS ^f	4	5	7.2	mA
Idle—WCDMA	<ul style="list-style-type: none"> Registered DRX=8 	USB active	37	38	39	mA
		USB-SS ^f	1.2	1.8	2.5	mA
Idle—LTE	<ul style="list-style-type: none"> Registered Paging cycle=256 	USB active	36	39	41	mA
		USB-SS ^f	2.7	2.9	3.7	mA
Airplane mode	Radio off	USB active	34	36	40	mA
		USB-SS ^f	1.2	1.4	1.6	mA
Power state—Ultra Low Power mode (ULPM)						
See Table 3-10 on page 45 for details.						

Table 3-8: WP7504 Current Consumption Values (Continued)

Mode	Parameter	Min	Typ ^a	Max ^b	Units
GNSS ^g					
GNSS ^h	Acquisition (Airplane mode, cold start)	30	40	50	mA
	Tracking (Registered)	25	35	45	mA

- a. Typical, measured at nominal temperature, nominal voltage.
- b. Worst case, measured over extreme temperature and voltage.
- c. At CDMA conducted max Tx output power (see [Table 3-19 on page 49](#))
- d. At WCDMA conducted max Tx output power (see [Table 3-17 on page 49](#))
- e. At LTE conducted max Tx output power (see [Table 3-22 on page 51](#))
- f. On Windows systems, due to limitations of the Windows ECM driver, USB-SS mode is only supported if ECM is disabled or USB is disconnected.
- g. GNSS current consumption values are for the GNSS radio only. For total consumption, add the GNSS value to the consumption for the mode being used.
- h. GNSS support is SKU-dependent.

Table 3-9: WP8548 Current Consumption Values

Mode	Parameter	Min	Typ	Max ^a	Units	
Power state—Active						
On Call—GSM ^b	850/900 MHz PCL5 +32 dBm	-	335 ^c	820 ^d	mA	
	1800/1900 MHz PCL0 +29 dBm	-	250 ^c	560 ^d	mA	
GSM Peak current ^b	850/900 MHz PCL5	-	-	2.5 ^d	A	
	1800/1900 MHz PCL0	-	-	1.5 ^d	A	
HSDPA Data transfer ^e	Band 1	450	550	650	mA	
	Band 2	450	550	650	mA	
	Band 5	350	500	600	mA	
	Band 6	330	500	550	mA	
	Band 8	410	550	650	mA	
	Band 19	330	500	550	mA	
Idle—GSM	<ul style="list-style-type: none"> • Registered • MFRMS=5 	USB active	36	39	40	mA
		USB-SS ^f	1.2	2.5	4.5	mA
Idle—WCDMA	<ul style="list-style-type: none"> • Registered • DRX=8 	USB active	37	38	39	mA
		USB-SS ^f	1.2	1.8	2.5	mA
Airplane mode	Radio off	USB active	34	36	40	mA
		USB-SS ^f	1.2	1.4	1.6	mA
Power state—Ultra Low Power Mode (ULPM)						
See Table 3-10 on page 45 for details.						

Table 3-9: WP8548 Current Consumption Values (Continued)

Mode	Parameter	Min	Typ	Max ^a	Units
GNSS ^g					
GNSS	Acquisition (Airplane mode, cold start)	30	40	50	mA
	Tracking (Registered)	25	35	45	mA

- Worst case, measured over extreme temperature and voltage.
- At GSM conducted max Tx output power (see [Table 3-12 on page 46](#))
- Typical—values for one slot
- Maximum—values for four slots with no backoff
- At WCDMA conducted max Tx output power (see [Table 3-15 on page 48](#))
- On Windows systems, due to limitations of the Windows ECM driver, USB-SS mode is only supported if ECM is disabled or USB is disconnected.
- GNSS current consumption values are for the GNSS radio only. For total consumption, add the GNSS value to the consumption for the mode being used.

[Table 3-10](#) describes parameters that contribute to total current consumption while the module is in ULPM.

Table 3-10: ULPM Current Consumption

Parameter		State	Value	Units
POWER_ON_N		Off	6	μA
		On	850	μA
MCU monitoring triggers	Wakeup timer	-	Insignificant	
	GPIO36 GPIO38 GPIO39 ADC2 ^a ADC3 ^a	Configured as open (default)	Insignificant	
		Other (Configured as closed and/or dependent on external circuitry design.)	≤ 50	μA

- Current consumption is affected by the interval between successive ADC measurements—longer intervals result in lower current consumption.

3.3 RF

This section presents the module's WWAN RF interface, and defines the specifications for the LTE, HSPA, WCDMA, GSM, and CDMA interfaces for supporting modules.

Note: RF sensitivity values presented in this section are for soldered-down modules. Sensitivity values decrease for modules installed in snap-in sockets, which might prevent the module from meeting 3GPP minimum specifications.

AirPrime WP75xx/AirPrime WP8548 embedded modules are designed to be compliant with the standards in [Table 3-11](#).

Table 3-11: Standards Compliance

Technology	Standards	WP7502	WP7504	WP8548
LTE	<ul style="list-style-type: none"> 3GPP Release 9 	Yes	Yes	
UMTS (WCDMA)	<ul style="list-style-type: none"> 3GPP Release 8 	Yes	Yes	Yes
CDMA	<ul style="list-style-type: none"> 3GPP2 C.S0011-D 3GPP2 C.S0033-C 		Yes	
GSM/GPRS/EDGE	<ul style="list-style-type: none"> 3GPP Release 8 	Yes		Yes

3.3.1 GSM RF Interface

This section presents the GSM RF specification for AirPrime WP7502 and AirPrime WP8548 modules.

3.3.1.1 GSM Tx Output Power

The module’s GSM maximum transmitter output power is specified in [Table 3-12](#).

Table 3-12: Conducted Tx Max Output Power Tolerances — GSM^a

RF band	Min	Typ	Max	Units	Notes	WP7502	WP7504	WP8548
GSM 850	31	32	33	dBm	GMSK mode (Power class 4; 2 W; 33 dBm)			Yes
E-GSM 900	31	32	33	dBm		Yes		Yes
DCS 1800	28	29	30	dBm	GMSK mode (Power class 1; 1 W, 30 dBm)	Yes		Yes
PCS 1900	28	29	30	dBm				Yes
GSM 850	25.5	26.5	27.5	dBm	8PSK mode (Power class E2; 0.5 W; 27 dBm)			Yes
E-GSM 900	25.5	26.5	27.5	dBm		Yes		Yes
DCS 1800	24.5	25.5	26.5	dBm	8PSK mode (Power class E2; 0.4 W, 26 dBm)	Yes		Yes
PCS 1900	24.5	25.5	26.5	dBm				Yes

a. Stated power tolerances satisfy 3GPP TS 51.010-1 requirements for normal (25°C) conditions.

3.3.1.2 GSM Rx Sensitivity

The module’s GSM receiver sensitivity is specified in [Table 3-13](#) (WP7502) and [Table 3-14](#) (WP8548).

Table 3-13: WP7502 Conducted Rx Sensitivity—GSM/EDGE Bands^a

GSM/EDGE Bands			Sensitivity @ +25°C (dBm) ^b	Sensitivity @ Class A (dBm) ^c	Standard Limit (dBm)
EGSM 900	2.44% BER CS	CS	-110.2	-109.8	-102
	10% BLER	GMSK CS1	-114.0	-113.2	-102
	10% BLER	EDGE MCS5	-105.5	-104.5	-98
DCS 1800	2.44% BER CS	CS	-107.6	-107.4	-102
	10% BLER	GMSK CS1	-111.2	-110.1	-102
	10% BLER	EDGE MCS5	-102.9	-101.5	-98

- a. Stated sensitivity values satisfy 3GPP TS 51.010-1 requirements for normal (25°C) and Class A (extreme) conditions.
- b. Typical value
- c. Typical value, tested at Class A extreme condition

Table 3-14: WP8548 Conducted Rx Sensitivity—GSM/EDGE Bands^a

GSM/EDGE Bands			Sensitivity @ +25°C (dBm) ^b	Sensitivity @ Class A (dBm) ^c	Standard Limit (dBm)
GSM 850	2.44% BER CS	CS	-109	-108	-102
	10% BLER	GMSK CS1	-113	-112	-102
	10% BLER	EDGE MCS5	-105	-104	-98
EGSM 900	2.44% BER CS	CS	-109	-108	-102
	10% BLER	GMSK CS1	-113	-112	-102
	10% BLER	EDGE MCS5	-105	-104	-98
DCS 1800	2.44% BER CS	CS	-108	-107	-102
	10% BLER	GMSK CS1	-112	-111	-102
	10% BLER	EDGE MCS5	-104	-103	-98
PCS 1900	2.44% BER CS	CS	-108	-107	-102
	10% BLER	GMSK CS1	-112	-111	-102
	10% BLER	EDGE MCS5	-104	-103	-98

- a. Stated sensitivity values satisfy 3GPP TS 51.010-1 requirements for normal (25°C) and Class A (extreme) conditions.
- b. Typical value
- c. Typical value, tested at Class A extreme condition

3.3.2 WCDMA RF Interface

This section presents the WCDMA RF specification for AirPrime WP75xx and AirPrime WP8548 modules.

3.3.2.1 WCDMA Tx Output Power

The module’s WCDMA maximum transmitter output power is specified in Table 3-15.

Table 3-15: Conducted Tx Max Output Power Tolerances—WCDMA^a

RF band	Min	Typ	Max	Units	Notes	WP7502	WP7504	WP8548
B1	22	23	24	dBm	Power class 3	Yes		Yes
B2	22	23	24	dBm	Power class 3		Yes	Yes
B4	22	23	24	dBm	Power class 3		Yes	
B5	22	23	24	dBm	Power class 3		Yes	Yes
B6	22	23	24	dBm	Power class 3			Yes
B8	22	23	24	dBm	Power class 3	Yes		Yes
B19	22	23	24	dBm	Power class 3			Yes

a. Stated power tolerances satisfy 3GPP TS 34.121-1 requirements for normal (25°C) conditions.

3.3.2.2 WCDMA Rx Sensitivity

The module’s GSM receiver sensitivity is specified in [Table 3-16](#) (WP7502), [Table 3-17](#) (WP7504) and [Table 3-14](#) (WP8548).

Table 3-16: WP7502 Conducted Rx Sensitivity—WCDMA Bands^a

Band	+25°C		Class A		Standard Limit (dBm)	Notes
	Primary (dBm) ^b	Secondary (dBm) ^b	Primary (dBm) ^c	Secondary (dBm) ^c		
B1	-111.3	-111.2	-110.5	-111.5	-106	CS 0.1% BER 12.2 kbps Reference Measurement Channel
B8	-112.1	-112.3	-111.6	-110.4	-103	

a. Stated sensitivity values satisfy 3GPP TS 34.121-1 V8.10.0 requirements for normal (25°C) and Class A (extreme) conditions.

b. Typical value

c. Typical value, tested at Class A extreme condition

Table 3-17: WP7504 Conducted Rx Sensitivity—WCDMA Bands^a

Band	+25°C		Class A		Standard Limit (dBm)	Notes
	Primary (dBm) ^b	Secondary (dBm) ^b	Primary (dBm) ^c	Secondary (dBm) ^c		
B2	-110.2	-110.3	-109.3	-109.5	-104	CS 0.1% BER 12.2 kbps Reference Measurement Channel
B4	-110.1	-112.0	-109.3	-111.0	-106	
B5	-111.9	-111.8	-110.8	-110.8	-104	

- a. Stated sensitivity values satisfy 3GPP TS 34.121-1 V8.10.0 requirements for normal (25°C) and Class A (extreme) conditions.
- b. Typical value
- c. Typical value, tested at Class A extreme condition

Table 3-18: WP8548 Conducted Rx Sensitivity—WCDMA Bands^a

Band	Sensitivity @ +25°C (dBm) ^b	Sensitivity @ Class A (dBm) ^c	Standard Limit (dBm)	Notes
B1	-109	-108	-106	CS 0.1% BER 12.2 kbps Reference Measurement Channel
B2	-110	-109	-104	
B5	-111	-110	-104	
B6	-111	-110	-106	
B8	-111	-110	-103	
B19	-111	-110	-106	

- a. Stated sensitivity values satisfy 3GPP TS 34.121-1 V8.10.0 requirements for normal (25°C) and Class A (extreme) conditions.
- b. Typical value
- c. Typical value, tested at Class A extreme condition

3.3.3 CDMA RF Interface

This section presents the CDMA RF specification for AirPrime WP7504 modules.

3.3.3.1 CDMA Tx Output Power

The module’s CDMA maximum transmitter output power is specified in Table 3-19.

Table 3-19: WP7504 Conducted Tx Max Output Power Tolerances—CDMA^a

RF band	Operating condition	Min	Typ	Max	Units	Notes
BC0	Normal (25°C)	22	23	24	dBm	ERP_min: -7 dBW (0.2W) with antenna gain > 3 dBi

Table 3-19: WP7504 Conducted Tx Max Output Power Tolerances — CDMA^a

RF band	Operating condition	Min	Typ	Max	Units	Notes
BC1	Normal (25°C)	22	23	24	dBm	EIRP_min: -7 dBW (0.2W) with antenna gain > 1 dBi
BC10	Normal (25°C)	22	23	24	dBm	ERP_min: -7 dBW (0.2W) with antenna gain > 3 dBi

a. Stated power tolerances are compliant with 3GPP2 ERP/EIRP specifications.

3.3.3.2 CDMA Rx Sensitivity

The module's CDMA receiver sensitivity is specified in [Table 3-20](#).

Table 3-20: Conducted Rx Sensitivity — CDMA Bands ^{a,b}

Band		+25°C		Class A		Standard Limit (dBm)
		Primary (dBm) ^c	Secondary (dBm) ^c	Primary (dBm) ^d	Secondary (dBm) ^d	
BC0	CDMA 1x ^e	-109.1	-109.5	-108.0	-108.6	-104.0
	EVDO rev A ^f	-110.8	n/a	-109.8	n/a	-104.0
BC1	CDMA 1x ^e	-107.7	-108.4	-107.0	-107.2	-104.0
	EVDO rev A ^f	-109.6	n/a	-108.6	n/a	-104.0
BC10	CDMA 1x ^e	-108.7	-110.0	-107.9	-108.8	-104.0

- a. Stated sensitivity values satisfy 3GPP2 specifications.
- b. CS 0.1% BER 12.2 kbps Reference Measurement Channel
- c. Typical value
- d. Typical value, tested at Class A extreme condition
- e. CDMA 1x 0.5% FER
- f. EVDO rev A 0.5% PERS

3.3.4 LTE RF Interface

This section presents the LTE RF specification for AirPrime WP75xx modules.

3.3.4.1 LTE Tx Output Power

The module's LTE maximum transmitter output power is specified in [Table 3-21](#) (WP7502) and [Table 3-22](#) (WP7504).

Table 3-21: WP7502 Conducted Tx Max Output Power Tolerances — LTE^a

RF band	Operating condition	Min	Typ	Max	Units	Notes
B1	Normal (25°C)	22	23	24	dBm	Power class 3
B3	Normal (25°C)	22	23	24	dBm	Power class 3
B7	Normal (25°C)	21	22	23	dBm	Power class 3

Table 3-21: WP7502 Conducted Tx Max Output Power Tolerances — LTE^a

RF band	Operating condition	Min	Typ	Max	Units	Notes
B8	Normal (25°C)	22	23	24	dBm	Power class 3
B20	Normal (25°C)	22	23	24	dBm	Power class 3

a. Stated power tolerances satisfy 3GPP TS 36.521-1 requirements for normal (25°C) and Class A (extreme) conditions.

Table 3-22: WP7504 Conducted Tx Max Output Power Tolerances — LTE^a

RF band	Operating condition	Min	Typ	Max	Units	Notes
B2	Normal (25°C)	22	23	24	dBm	Power class 3
B4	Normal (25°C)	22	23	24	dBm	Power class 3
B5	Normal (25°C)	22	23	24	dBm	Power class 3
B12	Normal (25°C)	22	23	24	dBm	Power class 3
B17	Normal (25°C)	22	23	24	dBm	Power class 3
B25	Normal (25°C)	22	23	24	dBm	Power class 3
B26	Normal (25°C)	22	23	24	dBm	Power class 3

a. Stated power tolerances satisfy 3GPP TS 36.521-1 requirements for normal (25°C) and Class A (extreme) conditions.

3.3.4.2 LTE Rx Sensitivity

The module's LTE receiver sensitivity is specified in [Table 3-23](#) (WP7502) and [Table 3-24](#) (WP7504).

Table 3-23: WP7502 Conducted Rx Sensitivity — LTE Bands

LTE bands		+25°C (dBm)			Class A (dBm)			SIMO ^a (Worst case) ^b
		Primary (Typical)	Secondary (Typical)	SIMO ^a (Typical)	Primary (Typical)	Secondary (Typical)	SIMO ^a (Typical)	
B1	Full RB BW: 10 MHz ^c	-98.7	-98.9	-101.8	-98.1	-97.9	-100.9	-96.3
B3		-97.5	-97.6	-100.5	-98.1	-96.7	-100.2	-93.3
B7		-96.9	-97.0	-99.6	-96.3	-96.0	-98.9	-94.3
B8		-99.2	-99.9	-102.4	-98.6	-98.9	-101.7	-93.3
B20		-98.9	-97.5	-101.6	-98.9	-97.5	-100.9	-93.3

a. Same data signal is sent by network to both of the module's receivers using a combiner for SIMO.

b. Per 3GPP specification.

c. Sensitivity values scale with bandwidth:
 $x_MHz_Sensitivity = 10_MHz_Sensitivity - 10 \cdot \log(10 \text{ MHz} / x_MHz)$
 Note: Bandwidth support is dependent on firmware version.

Table 3-24: WP7504 Conducted Rx Sensitivity—LTE Bands

LTE bands		+25°C (dBm)			Class A (dBm)			SIMO ^a (Worst case) ^b
		Primary (Typical)	Secondary (Typical)	SIMO ^a (Typical)	Primary (Typical)	Secondary (Typical)	SIMO ^a (Typical)	
B2	Full RB BW: 10 MHz ^c	-97.4	-98.1	-100.8	-96.5	-97.0	-99.9	-94.3
B4		-97.8	-99.5	-101.7	-97.1	-98.6	-101.0	-96.3
B5		-99.1	-99.5	-102.5	-97.9	-98.6	-101.2	-94.3
B12		-98.8	-100.4	-102.8	-98.1	-99.7	-102.0	-93.3
B17		-98.4	-100.3	-102.6	-98.1	-100.0	-101.9	-93.3
B25		-97.4	-98.0	-100.7	-96.5	-96.9	-99.3	-92.8
B26		-98.9	-99.5	-102.3	-97.9	-98.6	-101.3	-93.8

- a. Same data signal is sent by network to both of the module’s receivers using a combiner for SIMO.
- b. Per 3GPP specification.
- c. Sensitivity values scale with bandwidth:

$$x_MHz_Sensitivity = 10_MHz_Sensitivity - 10 \cdot \log(10\text{ MHz}/x_MHz)$$
 Note: Bandwidth support is dependent on firmware version.

3.3.5 WWAN Antenna Interface

The following tables define the WWAN antenna interfaces of the AirPrime WP75xx and AirPrime WP8548.

Table 3-25: WP75xx WWAN Antenna Interface Pins

Pin #	Signal name	Direction	Function
30	GND		Diversity Antenna Ground
31	RF_DIV	Input	Diversity Antenna Interface
32	GND		Diversity Antenna Ground
48	GND		Primary Antenna Ground
49	RF_MAIN	Input/Output	Primary Antenna Interface
50	GND		Primary Antenna Ground
111	GND		Diversity Antenna Ground
113	GND		Diversity Antenna Ground
136	GND		Primary Antenna Ground
139	GND		Primary Antenna Ground

Table 3-26: WP8548 WWAN Antenna Interface Pins

Pin #	Signal name	Direction	Function
48	GND		Primary Antenna Ground
49	RF_MAIN	Input/Output	Primary Antenna Interface
50	GND		Primary Antenna Ground
136	GND		Primary Antenna Ground
139	GND		Primary Antenna Ground

3.3.5.1 WWAN Antenna Recommendations

Table 3-27 defines the key characteristics to consider for antenna selection.

Table 3-27: Antenna Recommendations^a

Parameter	Recommendations	Comments
Antenna system	External multi-band antenna system	WP75xx—Dual WWAN antennas for diversity (Antenna 1/Antenna 2) ^b <ul style="list-style-type: none"> WP8548—Single WWAN antenna
<p>Important: Some specifications are not compatible with each other—the 3GPP specification for GSM/WCDMA/LTE max conducted power range, the 3GPP2 specification for CDMA/EVDO max radiated power range, and FCC radiated limits. As a result, the antennas that are used with WP8548 and WP7502 must meet different peak gains—gain > 3dBi for WP7504 in CDMA BC0/10, and gain < 3dBi for WP8548 in WCDMA/GSM 850/1900 MHz.</p>		

Table 3-27: Antenna Recommendations^a (Continued)

Parameter		Recommendations	Comments
Operating bands	WP7502 (Antenna 1)	791–960 MHz	Operating bands depend on the module's supported bands/modes.
		1710–1980 MHz	
		2110–2170 MHz	
		2500–2690 MHz	
	WP7502 (Antenna 2)	791–960 MHz	Operating bands depend on the module's supported bands/modes.
		1805–1880 MHz	
		2110–2170 MHz	
		2620–2690 MHz	
	WP7504 (Antenna 1)	699–894 MHz	Operating bands depend on the module's supported bands/modes.
		1710–1995 MHz	
		2110–2155 MHz	
	WP7504 (Antenna 2)	729–894 MHz	Operating bands depend on the module's supported bands/modes.
1930–1995 MHz			
2110–2155 MHz			
WP8548	824–960 MHz	Operating bands depend on the module's supported bands/modes.	
	1710–1990 MHz		
	2110–2170 MHz		
VSWR		< 2.5:1 (worst case)	<ul style="list-style-type: none"> • 1:1 (ideal) • On all bands including band edges • WP75xx—Applies to both antennas
Total radiated efficiency		> 50% on all bands	<ul style="list-style-type: none"> • Measured at the RF connector. • WP75xx—Applies to both antennas • Includes mismatch losses, losses in the matching circuit, and antenna losses, excluding cable loss. • Sierra Wireless recommends using antenna efficiency as the primary parameter for evaluating the antenna system. • Peak gain is not a good indication of antenna performance when integrated with a host device (the antenna does not provide omnidirectional gain patterns). Peak gain can be affected by antenna size, location, design type, etc.—the antenna gain pattern remains fixed unless one or more of these parameters change.
Radiation patterns		Nominally omnidirectional radiation pattern in azimuth plane.	<ul style="list-style-type: none"> • WP75xx—Applies to both antennas

Table 3-27: Antenna Recommendations^a (Continued)

Parameter		Recommendations	Comments
Envelope correlation coefficient between Antenna 1 and Antenna 2		<ul style="list-style-type: none"> < 0.5 on Rx bands below 960 MHz < 0.2 on Rx bands above 1.4 GHz 	
Mean Effective Gain (MEG)		≥ -3 dBi	<ul style="list-style-type: none"> WP75xx—Applies to both antennas (Antenna 1—MEG1, Antenna 2—MEG2)
Mean Effective Gain Imbalance—Antenna 1 and Antenna 2 (MEG1 / MEG2)	WP75xx	< 6 dB for diversity operation	
Maximum antenna gain		Must not exceed antenna gains due to RF exposure and ERP/EIRP limits, as listed in the module's FCC grant.	
Isolation between Antenna 1 and Antenna 2 (S21)	WP75xx	> 10 dB	<ul style="list-style-type: none"> If antennas can be moved, test all positions for both antennas. Unless otherwise specified, this isolation requirement must be maintained for optimum operation. Make sure all other wireless devices (Bluetooth or WLAN antennas, etc.) are turned OFF to avoid interference.
Maximum voltage applied to antenna		6.3 VDC	
Power handling		<ul style="list-style-type: none"> > 2 W RF power on low bands > 1 W on high bands 	<ul style="list-style-type: none"> Measure power endurance over 4 hours (estimated talk time) using a 2 W CW signal—set the CW test signal frequency to the middle of the PCS Tx band (1880 MHz for PCS). Visually inspect device to ensure there is no damage to the antenna structure and matching components. VSWR/TIS/TRP measurements taken before and after this test must show similar results.

a. These worst-case VSWR figures for the transmitter bands may not guarantee RSE levels to be within regulatory limits. The device alone meets all regulatory emissions limits when tested into a cabled (conducted) 50 ohm system. With antenna designs with up to 2.5:1 VSWR or worse, the radiated emissions could exceed limits. The antenna system may need to be tuned in order to meet the RSE limits as the complex match between the module and antenna can cause unwanted levels of emissions. Tuning may include antenna pattern changes, phase/delay adjustment, passive component matching. Examples of the application test limits would be included in FCC Part 22, Part 24 and Part 27, test case 4.2.16 for GSM (ETSI EN 301 511), and test case 4.2.2 for WCDMA (ETSI EN 301 908-1), where applicable.

b. Antenna 1—Primary (RF_MAIN), Antenna 2 (WP75xx only)—Secondary (RF_DIV) (Diversity)

3.4 GNSS

Note: GNSS is supported on AirPrime WP8548 modules, and is a SKU-dependent feature on AirPrime WP75xx modules.

The AirPrime WP75xx/AirPrime WP8548 includes Global Navigation Satellite System (GNSS) capabilities via the QUALCOMM IZat™ Gen8A Engine (formerly gpsOne), capable of operation in assisted and standalone GNSS modes (GPS/Galileo/GLONASS).

Note: AirPrime WPx5xx modules are not affected by the 2019 GPS week rollover. Software modifications extend the GPS rollover date to 12 December 2032.

3.4.1 GNSS Characteristics

The GNSS implementation supports GPS L1, Galileo E1, and GLONASS L1 FDMA operation.

Note: RF sensitivity values presented in this section are for soldered-down modules. Sensitivity values decrease for modules installed in snap-in sockets.

Table 3-28: GNSS Characteristics

Parameter		Value
Sensitivity	Standalone or MS-based tracking sensitivity	-161 dB
	Cold start sensitivity	-145 dB
	MS-assisted GNSS acquisition sensitivity	-158 dBm
Accuracy in open sky (1 Hz tracking)		< 2 m CEP-50
Satellite channels available ^a	Acquisition	118
	Simultaneous tracking	40
Support for predicted orbits		Yes
Predicted orbit CEP-50 accuracy		5 m
Standalone Time To First Fix (TTFF)	Hot	1 s
	Warm	29 s
	Cold	32 s
GNSS message protocols		NMEA
Altitude (max)		18,288 m (60,000 ft)
Velocity (max)		1,852 km/h (1150.8 mph)
Acceleration (max)		20 m/s ²

a. Resources are dynamically assigned and not constellation-specific.

Note: Acquisition/tracking sensitivity performance figures assume open sky with active patch GNSS antenna and a 2.5 dB noise figure.

3.4.2 GNSS Antenna Interface

The GNSS antenna interface is defined in [Table 3-29](#).

Table 3-29: GNSS Antenna Interface Pads

Pad	Name	Direction ^a	Function
37	GND		GNSS Antenna Ground
38	RF_GNSS	Input	GNSS Antenna Interface
39	GND		GNSS Antenna Ground
125	GND		GNSS Antenna Ground
128	GND		GNSS Antenna Ground

a. Signal direction with respect to the module.

Note: On WP75xx modules, GNSS functionality is available on the dedicated GNSS antenna only; it is not available on the diversity antenna.

3.4.2.1 GNSS Antenna Recommendations

[Table 3-30](#) defines the key characteristics to consider for antenna selection.

Table 3-30: GNSS Standalone Antenna Recommendations

Parameter	Recommendations	Notes
Frequency range	<ul style="list-style-type: none"> Wide-band GPS, Galileo, and GLONASS: 1573–1606 MHz recommended Narrow-band GPS: 1575.42 MHz ± 2.046 MHz minimum 	
Field of view (FOV)	<ul style="list-style-type: none"> Omni-directional in azimuth -45° to +90° in elevation 	
Polarization (average Gv/Gh)	> 0 dB	Vertical linear polarization is sufficient.
Free space average gain (Gv+Gh) over FOV	> -6 dBi (preferably > -3 dBi)	Gv and Gh are measured and averaged over -45° to +90° in elevation, and ±180° in azimuth.
Gain	<ul style="list-style-type: none"> Maximum gain and uniform coverage in the high elevation angle and zenith. Gain in azimuth plane is not desired. 	
Average 3D gain	> -5 dBi	

Table 3-30: GNSS Standalone Antenna Recommendations (Continued)

Parameter	Recommendations	Notes
Isolation between GNSS and RF Antenna	> 10 dB in all uplink bands	
Typical VSWR	< 2.5:1	
Polarization	Any other than LHCP (left-hand circular polarized) is acceptable.	Type of antenna and polarization (RHCP/linear) to be implemented is a matter of consideration based on specific end application.
Maximum voltage applied to antenna	6.3 VDC	
700 MHz harmonic ^a	< -56 dBm (input jammer 787.76 MHz at -25 dBm and measure the harmonic tone at 1575.42 MHz)	This specification is for B13 coexistence.
IIP2 ^a	> 45 dBm (Input jammers at 824.6 MHz with level -25 dBm and 2400 MHz with level -32 dBm and measure output IM2 at 1575.4 MHz)	Out of band
IIP3 ^a	> 2 dBm (Input jammers at 1712.7 MHz with level -20 dBm and 1850 MHz with level -65 dBm and measure output IM3 at 1575.4 MHz)	Out of band
Input 1 dB power compression point ^a	> -10 dBm	
Out of band rejection for an active antenna		
777–798 MHz	> 50 dB	
814–915 MHz	> 40 dB	50 dB is preferred
925–960 MHz	> 30 dB	50 dB is preferred
1427–1463 MHz	> 35 dB	
1710–1785 MHz	> 35 dB	
1850–1980 MHz	> 40 dB	
2010–2025 MHz	> 40 dB	
2305–2315 MHz	> 40 dB	
2401–2483 MHz	> 40 dB	
2500–2570 MHz	> 35 dB	

a. For the LNA used by an active antenna

3.5 Electrical Specifications

This section provides details of the key electrical specifications of the AirPrime WP75xx/ AirPrime WP8548 embedded module.

3.5.1 Absolute Maximum Ratings

This section defines the absolute maximum ratings of the AirPrime WP75xx/AirPrime WP8548.

Warning: *If these parameters are exceeded, even momentarily, damage may occur to the device. In addition, extended application of Absolute Maximum Rating conditions to the device may reduce device reliability.*

Note: Operation above the maximum specified operating voltage (see [Table 3-4 on page 36](#)) is not recommended, and specified typical performance or functional operation of the device is neither implied nor guaranteed.

Table 3-31: Absolute Maximum Ratings

Parameter		Min	Typ	Max	Units	
Power supply voltages						
VBAT_BB/ VBAT_RF	Power Supply Input	WP7502	-0.3	-	4.6	V
		WP7504	-0.3	-	5.5	V
		WP8548	-0.3	-	6.0	V
VDD_Px (low-voltage operation)	Digital pad circuits	-	-	2.2	V	
VDD_Px (high-voltage operation)	Digital pad circuits	-	-	3.05	V	
USB signal pins						
USB_D+	High-speed USB data plus	-	-	3.6	V	
USB_D-	High-speed USB data minus	-	-	3.6	V	
USB_VBUS	High-speed USB bus voltage	-	-	5.25	V	
Thermal conditions						
TS	Storage temperature	-40		85	°C	
TJ	Junction temperature	-	-	130	°C	
Maximum voltage applied to antenna interface pins						
VANT	RF_MAIN	-		6.3	Vdc	
	RF_DIV (WP75xx only)	-		6.3	Vdc	
	RF_GNSS	-		6.3	Vdc	
ESD ratings						
See EMC and ESD Recommendations on page 99 .						

3.5.2 Digital I/O Characteristics

The I/O characteristics for supported digital interfaces are described in:

- [Table 3-32](#)—HSIC signals
- [Table 3-33](#)—GPIOs, UART, ANT_CNTL, TX_ON, and PCM/I²S signals
- [Table 3-34](#)—SDIO signals

Table 3-32: Digital I/O Characteristics ($V_{DD_PX} = 1.20\text{ V}$ (nominal))

Parameter		Comments	Min	Max	Units
V_{IH}	High level input voltage	CMOS	$0.65 * V_{DD_PX}$	-	V
V_{IL}	Low level input voltage	CMOS	-	$0.35 * V_{DD_PX}$	V
I_{IH}	Input high leakage current ^a	No pull-down	-	2	μA
I_{IL}	Input low leakage current ^b	No pull-up	-2	-	μA
RPHSIC	HSIC pull up/down resistance	For HSIC_STRB and HSIC_DATA pins	17	60	$\text{k}\Omega$
RKHSIC	HSIC keeper resistance	For HSIC_STRB and HSIC_DATA pins	17	60	$\text{k}\Omega$
V_{OH}	High level output voltage	CMOS, at pin-rated drive strength	$0.9 * V_{DD_PX}$	-	V
V_{OL}	Low level output voltage	CMOS, at pin-rated drive strength	-	$0.1 * V_{DD_PX}$	V
I_{OZH}	Tri-state leakage current ^a	Logic high output	-	1	μA
I_{OZL}	Tri-state leakage current ^a	Logic low output	-1	-	μA
C_{IN}	Input capacitance ^c		1	2	pF
$C_{I/O}$	I/O capacitance ^c	I/O pins	1.25	2.5	pF

a. Pin voltage = V_{DD_PX} max.

b. Pin voltage = GND and supply = V_{DD_PX} max.

c. Input capacitance and I/O capacitance values are guaranteed by design, but is not 100% tested.

Table 3-33: Digital I/O Characteristics ($V_{DD_PX} = 1.80\text{ V}$ (nominal))

Parameter		Comments	Min	Max	Units
V_{IH}	High level input voltage	CMOS/Schmitt	$0.65 * V_{DD_PX}$	$V_{DD_PX} + 0.3$	V
V_{IL}	Low level input voltage	CMOS/Schmitt	-0.3	$0.35 * V_{DD_PX}$	V
V_{SHYS}	Schmitt hysteresis voltage		100	-	mV
I_{IH}	Input high leakage current ^a	No pull-down	-	1	μA
I_{IL}	Input low leakage current ^b	No pull-up	-1	-	μA
R_P	Pull up/down resistance		55	390	$\text{k}\Omega$
R_{PSD}	High-V pad pull up/down resistance	For SDCD1_CLK, SDC1_CMD, SDC1_DATA[3:0], GPIO[3:1], and GPIO[7:5] pins	10	100	$\text{k}\Omega$
V_{OH}	High level output voltage	CMOS, at pin-rated drive strength	$V_{DD_PX} - 0.45$	V_{DD_PX}	V
V_{OL}	Low level output voltage	CMOS, at pin-rated drive strength	0	0.45	V

Table 3-33: Digital I/O Characteristics ($V_{DD_PX} = 1.80\text{ V}$ (nominal)) (Continued)

Parameter		Comments	Min	Max	Units
I_{OZH}	Tri-state leakage current ^a	Logic high output, no pull-down	-	1	μA
I_{OZL}	Tri-state leakage current ^b	Logic low output, no pull-up	-1	-	μA
R_K	Keeper resistance		30	150	$\text{k}\Omega$
R_{KSD}	High-V pad keeper resistance	For SDCD1_CLK, SDC1_CMD, SDC1_DATA[3:0], GPIO[3:1], and GPIO[7:5] pins	10	100	$\text{k}\Omega$
I_{ISL}	Sleep crystal input leakage		-0.15	0.15	μA
I_{IHVKP}	High-V tolerant input leakage	With keeper	-1	-	μA
C_{IN}	Input capacitance ^c		-	5	pF
I_{PIN}	Current per pin		-	16	mA

- a. Pin voltage = V_{DD_PX} max. For keeper pins, pin voltage = V_{DD_PX} max - 0.45 V.
 b. Pin voltage = GND and supply = V_{DD_PX} max. For keeper pins, pin voltage = 0.45 V and supply = V_{DD_PX} max.
 c. Input capacitance is guaranteed by design, but is not 100% tested.

Table 3-34: Digital I/O Characteristics ($V_{DD_PX} = 2.95\text{ V}$ (nominal) signals)

Parameter		Comments	Min	Max	Units
V_{IH}	High level input voltage	CMOS/Schmitt	$0.65 * V_{DD_PX}$	$V_{DD_PX} + 0.3$	V
V_{IL}	Low level input voltage	CMOS/Schmitt	-0.3	$0.25 * V_{DD_PX}$	V
V_{SHYS}	Schmitt hysteresis voltage		100	-	mV
I_{IH}	Input high leakage current ^a	No pull-down	-	10	μA
I_{IL}	Input low leakage current ^b	No pull-up	-10	-	μA
R_{PSD}	High-V pad pull up/down resistance	For SDIO_CLK, SDIO_CMD, SDIO_DATA[0:3]	10	100	$\text{k}\Omega$
I_{OZH}	Tri-state leakage current ^a	Logic high output, no pull-down	-	10	μA
I_{OZL}	Tri-state leakage current ^b	Logic low output, no pull-up	-10	-	μA
R_{KSD}	High-V pad keeper resistance	For SDIO_CLK, SDIO_CMD, SDIO_DATA[0:3]	10	100	$\text{k}\Omega$
V_{OH}	High-level output voltage	CMOS, at pin-rated drive strength	$V_{DD_PX} - 0.45$	V_{DD_PX}	V
V_{OL}	Low-level output voltage	CMOS, at pin-rated drive strength	0	0.45	V
C_{IN}	Input capacitance ^c		-	5	pF
I_{PIN}	Current per pin		-	8	mA

- a. Pin voltage = V_{DD_PX} max. For keeper pins, pin voltage = V_{DD_PX} max - 0.45 V.
 b. Pin voltage = GND and supply = V_{DD_PX} max. for keeper pins, pin voltage = 0.45 V and supply = V_{DD_PX} max.
 c. Input capacitance is guaranteed by design, but is not 100% tested.

3.5.3 Internal Device Frequencies

[Table 3-35](#) summarizes the frequencies generated within the AirPrime WP75xx/AirPrime WP8548. This table is provided for reference only to the device integrator.

Table 3-35: Internal Device Frequencies

Subsystem/Feature	Frequency	Units
Real Time Clock	32.768	kHz
PCM Audio Interface (PCM Master Mode)	<ul style="list-style-type: none"> • 128 • 2048 	kHz
I ² C Interface	100	kHz
PMIC switching power supplies	1.6	MHz
Fundamental clock	19.2	MHz
PLL	<ul style="list-style-type: none"> • PLL0: 276.000 • PLL4: 393.216 • PLL5: 576.000 • PLL6: 460.800 • PLL7: 499.200 • PLL8: 384.000 • PLL9: 440.000 (v1) / 550.000 (v2+) • PLL11: 400.000 • PLL14: 480.000 	MHz
SPI	26	MHz
USB	480	Mb/s

3.6 Processing

3.6.1 Application Core

The Application Core is based on a Cortex A5 32-bit RISC architecture core. It has the following main characteristics:

- Up to 550 MHz operation
- Cache: Instruction (32kB) and Data (32kB)

The Application Core supports Legato™, an open source embedded platform built on Linux, which allows the simultaneous safe running of multiple applications.

Refer to [Interfaces Specification on page 68](#) for the list of interfaces supported by this core.

3.6.2 Embedded Memory

The AirPrime WP75xx/AirPrime WP8548 module includes Flash and RAM embedded memory as detailed in [Table 3-36](#).

Table 3-36: Embedded Memory Details^a

Type	Details	Size
Flash	Total	512 MB
	Reserved for Application processor	256 MB
	Minimum number of write cycles	50,000
RAM	Total	256 MB
	Reserved for Application processor	128 MB

a. Preliminary values, subject to change.

The application processor memory is dedicated to the Legato platform, including:

- Linux kernel
- Root file system
- Application framework
- Customer applications

3.6.2.1 Embedded Memory Available for Customer Use

Flash memory

As shown in [Figure](#) , the Flash memory is partitioned for use by various elements of the application processor. Partitions mtd0–mtd3 can be used by the customer to install custom firmware, and mtd4 can be used to install custom Legato applications. The remaining partitions are reserved for internal use.

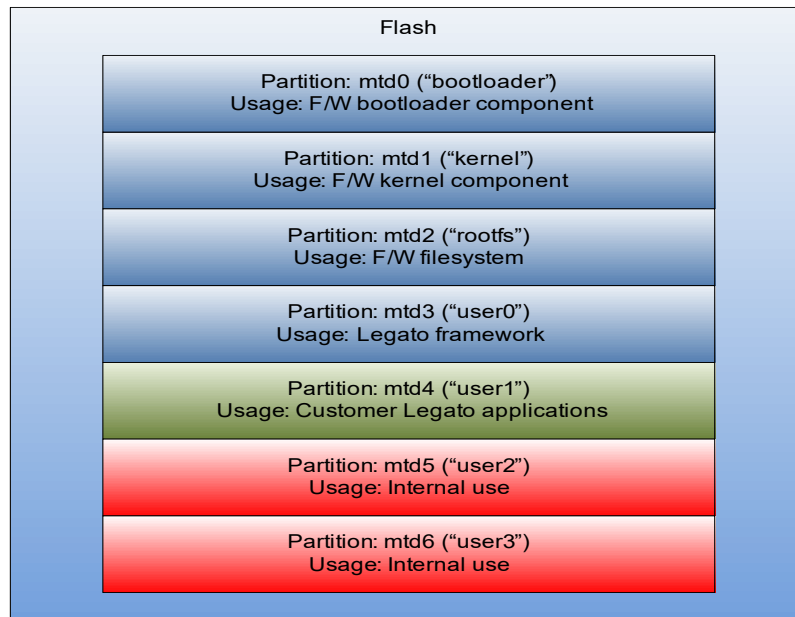


Figure 3-4: Flash Memory Partitions

To display partition sizes, and to determine whether a customer firmware will fit:

1. Connect to the WP module.
2. Use the Linux command 'cat /proc/mtd'. Partition sizes are listed in the 'size' column.

```
root@swi-mdm9x15:~# cat /proc/mtd
dev:   size erasesize name
mtd0: 00100000 00020000 "bootloader"
mtd1: 01400000 00020000 "kernel"
mtd2: 03140000 00020000 "rootfs"
mtd3: 02780000 00020000 "user0"
mtd4: 08b80000 00020000 "user1"
mtd5: 00500000 00020000 "user2"
mtd6: 00200000 00020000 "user3"
```

3. When building an image, use the swicwe command to display the sizes of the image components to ensure they can fit in the associated partitions.

For example, using the WPx5 Release 15 Linux (yocto cwe) and Legato (legato cwe) image components:

```
myname@mysystem:/$ swicwe -P boot-yocto_wp85.cwe
Type      Size(Exclude Header)  Product      Compress  Version
*APPL    29964923              Y912         0         Wed Nov 29 21:02:47 PST 2017
SYST     25891769              9X15        1         Wed Nov 29 21:02:47 PST 2017
APBL      74576                 9x15        0         Wed Nov 29 21:02:47 PST 2017
APPS     3997378               9x15        1         Wed Nov 29 21:02:47 PST 2017

myname@mysystem:/$ swicwe -P legatoz-16.10.4_wp85.cwe
Type      Size(Exclude Header)  Product      Compress  Version
*APPL    2311153              Y912         0         16.10.4 df5b086 jenkins 2017/09/29 20:11:02
SYST     2310753              9X15        1         16.10.4 df5b086 jenkins 2017/09/29 20:11:02
```

- Yocto component, SYST—To be stored in mtd2 ("rootfs")
- Yocto component, APBL—To be stored in mtd0 ("bootloader")
- Yocto component, APPS—To be stored in mtd1 ("kernel")
- Legato component, SYST—To be stored in mtd3 ("user0")

RAM

To display the amount of RAM currently available for use by customer applications:

1. Connect to the WP module.

2. Use the Linux command 'free -m' to display the free RAM.

The total free memory (at this moment) includes the Mem 'free' and the cache 'free'.

For example, as shown below, available RAM at the time the command is run is 58 + 81 = 139 MB.

```

root@swi-mdm9x15:~# free -m
              total          used         free       shared  buff/cache   available
Mem:           149             38           58            2           52          102
-/+ buffers/cache:
Swap:            0              0              0
    
```

3.6.3 Recovery Mechanisms

The AirPrime WP75xx/AirPrime WP8548 employs recovery mechanisms for the Embedded File System (EFS) and for the modem component of the firmware image.

Important: *To avoid the potential for memory corruption, make sure to always follow the proper power off procedure before removing power from the module. (Figure 4-1 on page 70 illustrates the signal timing details for powering off the module.)*

3.6.3.1 EFS Recovery

The AirPrime WP75xx/AirPrime WP8548 has the capability to automatically detect and recover from various EFS memory corruption scenarios.

For example, the EFS could be corrupted by:

- Unexpected (uncontrolled) module reset (e.g. due to power failure or other causes)
- Out-of-range supply voltage fluctuations
- Out-of-range operating temperature
- etc.

Each time the device boots and the file system mounts successfully, a backup of the file system is stored (the device will retain several backups).

EFS corruption can be detected while initializing when the device boots, as well as at runtime. To prevent unnecessary recovery, the recovery mechanism causes the module to reset and boot with the existing EFS. If the issue re-occurs (i.e. the EFS is confirmed to be corrupt), the module checks the stored backups and automatically restores the most recent good backup.

3.6.3.2 Linux Firmware Component Recovery

On modules that support Image Switching, the modem component of the firmware image will, if corrupted, be automatically restored from an image slot.

3.7 Mechanical Drawing

The AirPrime WP75xx/AirPrime WP8548 module's LGA footprint is a 239-pad array of copper pads (see [Physical Dimensions and Connection Interface on page 21](#)). The following drawing illustrates the device footprint and dimensions.

>> 4: Interfaces Specification

4.1 Overview

This section describes the interfaces supported by the AirPrime WP75xx/AirPrime WP8548 embedded module and provides specific voltage, timing, and circuit recommendations for each interface.

4.2 BAT_RTC

The AirPrime WP75xx/AirPrime WP8548 module's internal RTC is powered from the VBAT_BB supply (when available).

The module also provides an interface (BAT_RTC) for using a coin cell to maintain the internal RTC when VBAT_BB is removed from the module. The coin cell can also be charged via BAT_RTC when VBAT_BB is available.

Note: The coin cell will not charge when the device is in ULPM.

Table 4-1: BAT_RTC Pin

Pin	Name	Direction	Function	If Unused
21	BAT_RTC	Input/Output	Voltage input/Charging output	Leave Open

Table 4-2: BAT_RTC Charging Specifications

Specification	Comments	Min	Typ	Max	Units
Target regulator voltage ^a	$V_{IN} > 3.3 \text{ V}$, $I_{CHG} = 100 \mu\text{A}$	2.5	-	3.2	V
Target series resistance ^b		800	-	2100	Ω
Coin cell voltage		2.0	-	3.25	V
Coin cell charger voltage error	$I_{CHG} = 0 \mu\text{A}$	-5	-	+5	%
Coin cell charger resistor error		-20	-	+20	%
Dropout voltage ^c	$I_{CHG} = 2 \text{ mA}$	-	-	200	mV
Current draw	Charging	-	2.0	-	mA
	Off	-	5.0	8.0	μA
Ground current, charger enabled	VBAT=3.6V	-	4.5	-	μA
	VBAT=3.4–4.3 V	-	-	8.0	μA
Capacitance		-	-	4.7	μF

a. Programmable voltage: 2.5/3.0/3.1/3.2

b. Valid series resistor settings are 800, 1200, 1700, and 2100 Ω

c. Dropout is measured by reducing the supply voltage (VBAT) from 3.5 V until the charging voltage drops by 100 mV. Then calculate the dropout voltage: $V_{\text{dropout}} = \text{VBAT} - \text{charger output voltage}$.

4.3 POWER_ON_N

The AirPrime WP75xx/AirPrime WP8548 module requires a low level signal (POWER_ON_N) that is used to switch the module ON.

The signal is connected internally to the permanent 1.8V supply regulator inside the module via a pull-up resistor. Once VBAT_BB is supplied to the module, this 1.8V supply regulator will be enabled and so the POWER_ON_N signal is by default at high level.

Important: Use a momentary switch to control this line to reduce leakage current in ULPM mode. Holding POWER_ON_N low in ULPM mode incurs a significant current draw—see [Table 3-10 on page 45](#) for details.

[Table 4-3](#) describes the POWER_ON_N signal's characteristics.

Table 4-3: POWER_ON_N Electrical Characteristics

Parameter	Min	Typ	Max	Units
Input Voltage—Low		-	0.63	V
Internal pull-up resistor		200		k Ω
POWER_ON_N assertion time ^a	200			ms

a. Assertion time is the time required to keep POWER_ON_N at LOW level to ensure the module can be powered ON successfully.

4.3.1 Power-up Sequence

4.3.1.1 Power On/Off Timing

Figure 4-1 describes the timing sequence for powering the module on and off.

Note: Before reaching the “Active” state, signals on the host port are considered to be undefined and signal transitions may occur. This undefined state also applies when the module is in reset mode, during a firmware update, or during the Power-off sequence. The host must consider these undefined signal activities when designing the module interface.

Note: The host should not drive any signals to the module until > 100 ms from the start of the power-on sequence.

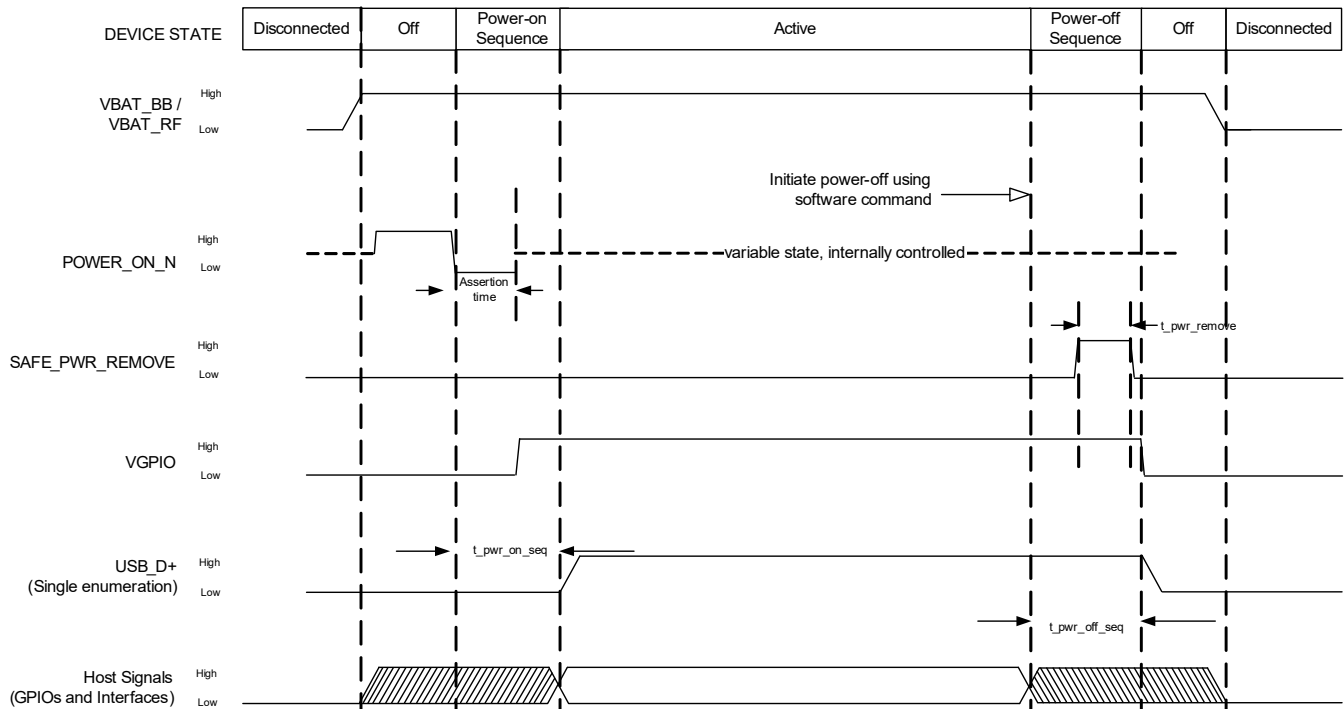


Figure 4-1: Signal timing ($POWER_ON_N$, and USB Enumeration)

Table 4-4: $POWER_ON_N$ Timing Parameters

Parameter	Typical	Maximum	Units
$t_{pwr_on_seq}$	14.5	15.5	s
$t_{pwr_off_seq}$	0.4–5.5	6	s
t_{pwr_remove}	13	-	ms

4.3.1.2 USB enumeration

The unit supports single USB enumeration with the host. Enumeration starts within (maximum) $t_{pwr_on_seq}$ seconds of power-on.

4.3.2 Software-Initiated Power Down

To power down the module via software:

1. Initiate the power down process:
ATIPOWERDOWN
2. Monitor VGPIO.
3. When VGPIO is low, remove power.

4.4 Emergency Power Off

The module can be switched off by controlling the RESET_IN_N pin. This must only be used in emergency situations if the system freezes (not responding to commands).

To perform an emergency power off:

1. De-assert POWER_ON_N.
2. While POWER_ON_N is de-asserted, assert RESET_IN_N (logic low) for at least 32 ms. This immediately powers down the module.

4.5 USB

The AirPrime WP75xx/AirPrime WP8548 implements one high-speed USB2.0 Interface, which conforms to the *Universal Serial Bus Specification, Revision 2.0*, except for USB_VBUS implementation (not connected internally).

See [USB Interface on page 98](#) for a reference USB schematic.

Table 4-5: USB Pin Descriptions

Pin	Signal name	Direction ^a	Function
12	USB_D-	Input/Output	Differential data interface negative
13	USB_D+	Input/Output	Differential data interface positive
16	Reserved	Input	For compatibility with Sierra Wireless HL devices, connect as indicated in the reference USB schematic.
16	USB_VBUS ^b	Input	USB supply voltage
91	USB_ID	Input	Used for USB_OTG

- a. Signal direction with respect to the module. Example: USB_ID is an input to the module from the host.
- b. Not currently connected internally, but customer solutions should provide this input for compatibility with future module revisions.

4.6 UART

The AirPrime WP75xx/AirPrime WP8548 provides two UART interfaces:

- UART1 (primary UART)—8-wire interface
- UART2 (secondary UART)—2-wire interface

The UART interfaces are used for data communication between the AirPrime WP75xx/AirPrime WP8548 module and a PC or host processor. These interfaces comply with the RS-232 interface.

Flow control is managed using the RTS/CTS signals, or using software XON/XOFF.

[Table 4-6 on page 72](#) describes the signals used for UART1 and UART2.

Note: UART signals are named with respect to the host device, and directions are listed with respect to the module. For example, UART1_RX is an output from the module to the host.

Table 4-6: UART Pins

Pin	Interface	Name ^a	Direction ^b	Function	If unused
2	UART1	UART1_RI	Output	Ring Indicator Signal incoming calls (voice and data), SMS, etc.	Leave open
3		UART1_RTS	Input	Ready To Send, flow control	Leave open ^c
4		UART1_CTS	Output	Clear To Send, flow control	Leave open
5		UART1_TX	Input	Transmit Data	Leave open
6		UART1_RX	Output	Receive Data	Leave open
7		UART1_DTR	Input (active low)	Data terminal ready Prevents the AirPrime WP75xx/ AirPrime WP8548 from entering USB-SS mode, switches between data mode and command mode, and wakes the module.	Leave open
8		UART1_DCD	Output	Data Carrier Detect Signal data connection in progress	Leave open
9		UART1_DSR	Output	Data Set Ready Signal UART interface is ON	Leave open
96	UART2	UART2_TX	Input	Transmit data	Leave open
97		UART2_RX	Output	Receive data	Leave open

- a. Signals are named with respect to the host device. For example, UART1_RX is the signal used by the host to receive data from the module.
- b. Signal direction with respect to the module. For example, UART1_RX is an output from the module to the host.
- c. If UART1 is implemented as a 2-wire interface, UART1_RTS should be pulled low to disable flow control.

4.7 UIM interface

The AirPrime WP75xx/AirPrime WP8548 has two physical UIM interfaces—UIM1 and UIM2, which support UIM for WCDMA and GSM.

Both UIM interfaces allow control of external 1.8V/3V UIMs and are fully compliant with GSM 11.11 recommendations concerning UIM functions.

[Table 4-7 on page 73](#) describes the signals used for UIM1 and UIM2.

Table 4-7: UIM Interface Pins

Pin	Interface	Name	Direction ^a	Function	If Unused
26	UIM1	UIM1_VCC	Output	Supply output	Leave open
27		UIM1_CLK	Output	Clock	Leave open
28		UIM1_DATA	Input/Output	Data connection	Leave open
29		UIM1_RESET_N	Output	Reset	Leave open
64		UIM1_DET	Input	Detect UIM	Leave open
55	UIM2	UIM2_VCC	Output	Supply output	Leave open
56		UIM2_DATA	Input/Output	Data connection	Leave open
57		UIM2_RESET_N	Output	Reset	Leave open
58		UIM2_CLK	Output	Clock	Leave open
65		UIM2_DET	Input	Detect UIM	Leave open

a. Signal direction with respect to the module. Examples: UIM1_DET (pin 64) is an input to the module from the host; UIM1_RESET_N (pin 29) is an output from the module to the host.

Figure 4-2 illustrates the recommended implementation of a UIM holder. (For a more detailed UIM schematic, see Figure 5-4 on page 100.)

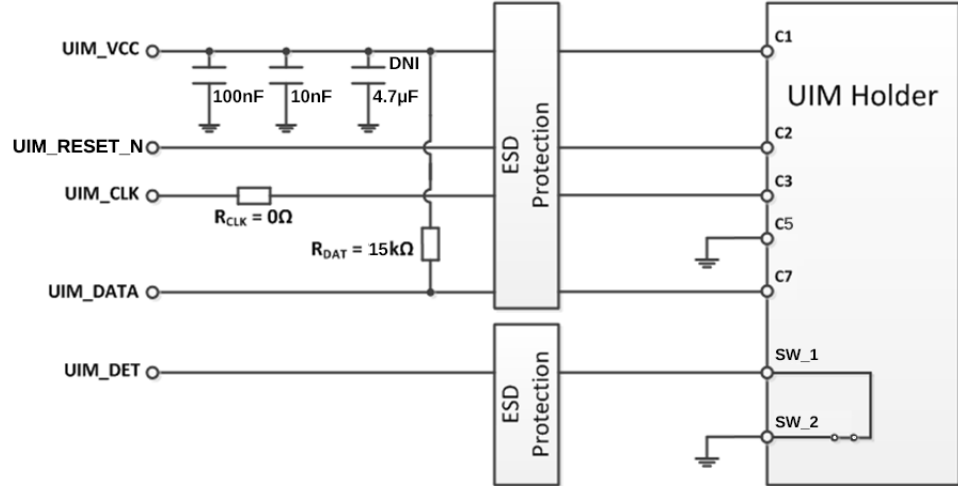


Figure 4-2: Recommended UIM Holder Implementation

The UIM Detect signals (UIM1_DET, UIM2_DET) are used to detect the physical presence of a UIM card in the UIM holder. Each UIM Detect signal has a pull-up internal to the AirPrime WP75xx/AirPrime WP8548. It should be set to GND when a UIM is not present. All signals near the UIM holder must be ESD-protected.

The UIM Detect signals transition:

- When a UIM is inserted—high (logic 0 to logic 1)
- When a UIM is removed—low (logic 1 to logic 0)

The capacitor and the two resistors, RCLK and RDATA, should be added as placeholders to compensate for potential layout issues. UIM_DAT trace should be routed away from the UIM_CLK trace. Keep the distance between the module and the UIM holder as short as possible.

An ESD device specifically designed for UIM cards is recommended for the UIM1 and UIM2 VCC, RESET_IN_N, CLK, and DAT signals (for example, STMicroelectronics DALC208SC6). For UIM1_DET/UIM2_DET a low leakage ESD suppressor should be selected.

4.8 General Purpose Input/Output (GPIO)

The AirPrime WP75xx/AirPrime WP8548 defines several GPIOs for customer use, as described in [Table 4-8](#). For electrical specifications, see [Table 3-33, Digital I/O Characteristics \(VDD_PX=1.80 V \(nominal\)\)](#), on page 60.

Note: In ULPM, all interfaces connected to GPIOs (except GPIO34–GPIO41) must be tri-stated or off to prevent additional leakage current during ULPM and potentially damaging the unit by applying a voltage when the GPIOs are off. Only GPIO34–GPIO41 can safely be used. Similarly, there should not be any voltage applied to the GPIOs when the module is off, to prevent damaging the module.

Table 4-8: GPIO Pin Description

Pin	Signal Name	Default state	Function	If Unused
10	GPIO2 ^a	Input, no pull ^b	General purpose I/O	Leave open
40	GPIO7			
41	GPIO8			
44	GPIO13			
92	GPIO38 ^{a,c,d}			
93	GPIO39 ^{a,c,d}			
94	GPIO40 ^{d,e}			
95	GPIO41 ^{d,e}			
100	GPIO34 ^d			
101	GPIO35 ^d			
102	GPIO36 ^{a,c,d}			
103	GPIO37 ^d			
104	GPIO32			
105	GPIO33			
109	GPIO42 ^a			
147	GPIO21 ^a			
148	GPIO22			
149	GPIO23			
150	GPIO24			
153	GPIO28 ^f			
154	GPIO29 ^f			
155	GPIO30 ^f			
156	GPIO31 ^f			
159	GPIO25			

- a. Pin is 'wakeable'. Can be used to trigger the module to wake up from USB-SS mode (low power active state). See [Wakeup Interrupt \(USB-SS Mode\) on page 76](#) for details.
- b. Internal configuration of all GPIOs—no internal pull-ups
- c. Can be configured as a wakeup trigger for ULPM. See [Wakeup Events \(ULPM\) on page 76](#) for details.
- d. Accessible via sysfs/Legato only.
- e. GPIO40 and GPIO41 may be unavailable in future WP products.
- f. GPIOs 28–31 are available for use when configured using AT+WIOCFG.

4.9 Wakeup Interrupt (USB-SS Mode)

The following pins can be used to wake the device when it is in USB-SS mode (low-power active state):

- GPIO2
- GPIO21
- GPIO36
- GPIO38
- GPIO39
- GPIO42
- UIM1_DET
- UIM2_DET

The GPIO pins can be configured as a wakeup source by using the +WIOCFG command (see [1] AirPrime WPx5/WP76xx/WP77xx AT Command Reference).

If the device firmware is monitoring these pins while the device is in USB-SS mode, any transition on these pins will wake the device. (Note: The UIMx_DET pins transition high when a UIM is installed, and low when a UIM is removed.)

Note: These signals wake the device when it is in USB-SS mode (a low-power ACTIVE state where the module is fully powered). If the device is in ULPM (Ultra Low Power Mode), it is only woken by configured wakeup triggers—see [Wakeup Events \(ULPM\)](#) on page 76 for details.

4.10 Wakeup Events (ULPM)

The following signals/sources can be used to wake the device from ULPM (Ultra Low Power Mode):

- Configurable:
 - Timer
 - GPIO36, GPIO38, GPIO39
 - ADC2, ADC3
- Always enabled:
 - POWER_ON_N

Note: These signals wake the device only when it is in ULPM. If the device is in regular USB-SS mode (a low-power ACTIVE state where the module is fully powered), it can be woken using the signals described in [Wakeup Interrupt \(USB-SS Mode\)](#) on page 76.

For ULPM details, see [Table 3-6, Supported Power States](#), on page 39.

4.11 Secure Digital IO (SDIO) interface

The AirPrime WP75xx/AirPrime WP8548 module defines a 3.0V SDIO interface (SD 2.0-compliant) for customer-defined use with SD cards, connection to a Wi-Fi module, etc.

Note: An external 3.0V supply is required to supply power to the SD card.

Table 4-9 describes the signals used for SDIO.

Table 4-9: SDIO Pin Descriptions

Pin	Signal Name	Direction ^a	Description	If unused	Voltage level
161	SDIO_CMD	Output	SDIO command	Leave Open	3.0V
162	SDIO_CLK	Output	SDIO clock	Leave Open	
163	SDIO_DATA_3	Input/Output	SDIO data bit 3	Leave Open	
164	SDIO_DATA_2	Input/Output	SDIO data bit 2	Leave Open	
165	SDIO_DATA_1	Input/Output	SDIO data bit 1	Leave Open	
166	SDIO_DATA_0	Input/Output	SDIO data bit 0	Leave Open	

a. Signal direction with respect to the module. Example: SDIO_CMD (pin 161) is an output from the module to the host.

4.12 I²C Interface

The AirPrime WP75xx/AirPrime WP8548 module provides one I²C (Inter-Integrated Circuit) dedicated serial port (bus interface) based on [5] The I2C Bus Specification, Version 2.1, January 2000 (Phillips Semiconductor document number 9398 393 40011).

The interface uses the pins indicated in Table 4-10.

Table 4-10: I²C Interface Pins

Pin	Signal name	Direction	Function	If Unused
1	I2C1_CLK	Input/Output	I ² C Clock	Leave open
66	I2C1_DATA	Input/Output	I ² C Data	Leave open

This implementation of the I²C interface includes the following characteristics:

- Supported voltage—1.8 V
- Standard-mode interface—Data transfer rates up to 100 kbit/s
- Master mode operation only—WP75xx/WP8548 module always operates as the master
- I²C signals are implemented internally as open drain outputs (per the I²C specification) with 2.2 k Ω pull-up resistors to VGPI0 (see Figure 4-3 on page 78).

For I²C bus details, including I2C bus waveform and timing details, refer to the I2C Bus Specification.

4.12.1 Application

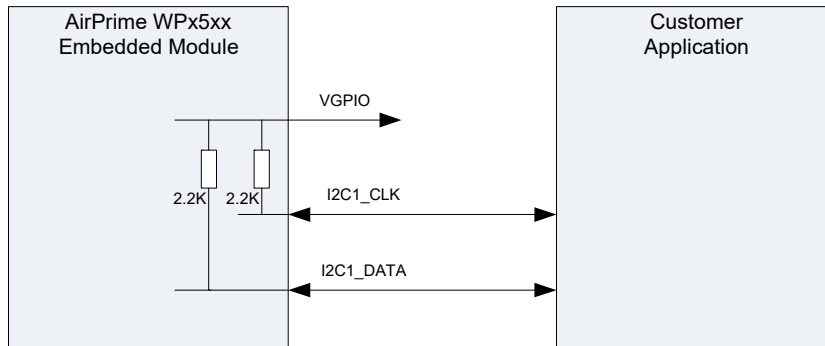


Figure 4-3: Example of I²C Bus Application

4.13 VGPIO

The AirPrime WP75xx/AirPrime WP8548 utilizes 1.8V logic, provided via the VGPIO (GPIO voltage output) pin.

Table 4-11: VGPIO Reference Pin

Pin	Signal name	Direction ^a	Function	If Unused
45	VGPIO	Output	GPIO voltage output	Leave open

a. Signal direction with respect to the module—VGPIO (pin 45) is an output from the module to the host.

Table 4-12: VGPIO Electrical Characteristics

Parameter	Min	Typ	Max	Unit	Remarks
Voltage level	1.7	1.8	1.9	V	Both active mode and USB-SS mode
	-	-	-	V	Off in ULPM
Current capability	-	-	50	mA	Power Management support up to 50 mA output

The VGPIO pin is available when the module is switched ON, and can be used to:

- Pull-up signals such as I/Os
- Supply external digital transistors driving LEDs
- Act as a voltage reference for the ADC interfaces—ADC0–ADC3

4.14 Reset Signal (RESET_IN_N)

The AirPrime WP75xx/AirPrime WP8548 provides the RESET_IN_N signal, which allows an external application to reset the module when it:

- has become unresponsive
and
- does not have a mechanism to perform a power cycle

Table 4-13: RESET_IN_N Pin

Pin	Signal name	Direction ^a	Function	If Unused
11	RESET_IN_N	Input	External Reset Input	Leave open

a. Signal direction with respect to the module—RESET_IN_N (pin 11) is an input to the module from the host.

RESET_IN_N is internally pulled-up with a 40 kΩ resistor. An open collector transistor or equivalent should be used to ground the signal to reset the module.

The effect of asserting RESET_IN_N depends on the state of POWER_ON_N:

- POWER_ON_N low—Module reboots with CPU registers and RAM memory reset.

Warning: RESET_IN_N must not be pulsed for more than $\max(\text{Trlen})$, otherwise the module may repeatedly reboot. See Table 4-14 for timing details.

Table 4-14: Reset Timing

Symbol	Parameter	Min	Typ	Max
Trdet	Duration of RESET_IN_N signal before firmware detects it (debounce timer)	-	32 ms	-
Trlen	Duration reset asserted	42 ms	-	500 ms
Trdel	Delay between minimum Reset duration and internal reset generated	-	500 ms	-

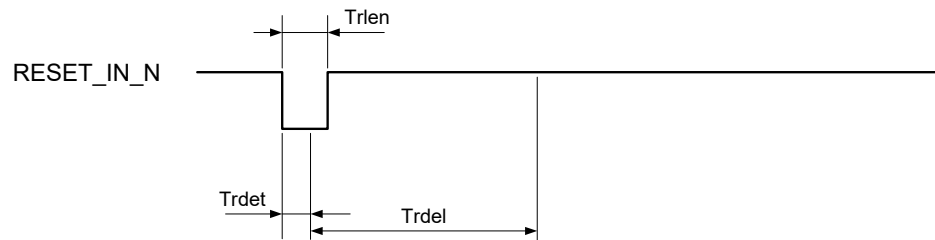


Figure 4-4: Illustration of Reset Timing When RESET_IN_N < Trdel

4.15 Reset Out (RESET_OUT_N)

The AirPrime WP75xx/AirPrime WP8548 provides a signal that will hold peripheral devices (such as a USB hub, I2C device, etc.) in reset until the power-up sequence is complete.

Table 4-15: RESET_OUT_N Pin

Pin	Signal name	Direction ^a	Function	If Unused
46	RESET_OUT_N	Output	Module reset peripheral device control	Leave open

- a. Signal direction with respect to the module—RESET_OUT_N is an output from the module to the host.

When the module is in reset or powering up, the signal is held low to put peripheral devices in reset. Once the power-on sequence is complete, the RESET_OUT_N signal will be turned high to take the peripherals out of reset.

4.16 ADC

The AirPrime WP75xx/AirPrime WP8548 provides four general purpose ADC (Analog to Digital Converter) inputs, as described [Table 4-16](#) and [Table 4-17](#).

Table 4-16: ADC Interface Pins

Pin	Signal name	Direction ^a	Function	If Unused
24	ADC1	Input	Analog to Digital Converter	Leave open or Ground
25	ADC0	Input	Analog to Digital Converter	Leave open or Ground
107	ADC2 ^b	Input	Analog to Digital Converter	Leave open or Ground
108	ADC3 ^b	Input	Analog to Digital Converter	Leave open or Ground

- a. Signal direction with respect to the module. Example: ADC1 (pin 24) is an input to the module from the host.
 b. Pin is 'wakeable'. Can be used to trigger the module to wake up from ULPM. See [Wakeup Events \(ULPM\) on page 76](#) for details.

Table 4-17: ADC Interface Characteristics

	ADC0/ADC1 Value	ADC2/ADC3 Value	Units
Full-scale voltage level	0–1.8	0–1.8	V
Resolution	15	12	bit
Sample rate	1.15	20.000–818.330	ksps
Voltage error	8 (Typ) 16 (Max)	2 (Typ)	mV

4.17 Digital Audio

The AirPrime WP75xx/AirPrime WP8548 provides a 4-wire digital audio interface that can be configured as either PCM (Pulse Code Modulation) or I²S (Inter-IC Sound).

[Table 4-18 on page 81](#) describes the audio interface signals.

Note: Audio availability is firmware-dependent.

Table 4-18: PCM/I²S Interface Signals

Pin	Signal name	Direction ^a	Function	If Unused
33	PCM_OUT	Output	PCM Data Out The frame “data out” relies on the selected configuration mode.	Leave open
	I2S_OUT	Output	I2S Data Out The frame “data out” relies on the selected configuration mode.	
34	PCM_IN	Input	PCM Data In The frame “data in” relies on the selected configuration mode.	Leave open
	I2S_IN	Input	I2S Data In The frame “data in” relies on the selected configuration mode.	
35	PCM_SYNC	Input/Output	PCM Sync The frame synchronization signal delivers an 8 kHz frequency pulse that synchronizes the frame data in and the frame data out.	Leave open
	I2S_WS	Output	I2S Word Select The word select clock indicates which channel is currently being transmitted (low cycle indicates left audio channel, high cycle indicates right audio channel).	
36	PCM_CLK	Input/Output	PCM Clock The frame bit clock signal controls data transfer with the audio peripheral.	Leave open
	I2S_CLK	Output	I2S Clock The frame bit clock signal controls data transfer with the audio peripheral.	

- a. Signal direction with respect to the module. Examples: PCM_IN (pin 34) is an input to the module from the host; PCM_OUT (pin 33) is an output from the module to the host.

4.17.1 PCM

Table 4-19 defines the PCM interface configuration.

Table 4-19: PCM Interface Configurations

Element	PCM
Slot configuration	Slot-based
Sync type	Short
Clock (in Master mode)	2.048 MHz
Data formats	16-bit linear, 8-bit A-law, 8-bit mu-law
Mode	Master or Slave

4.17.1.1 PCM Data Format

The PCM data is 8 kHz and 16 bits with the following PDM (Pulse-density modulation) bit format:

- PCM_DIN—SDDD DDDD DDDD DDVV
- PCM_DOUT—SDDD DDDD DDDD DDVV

Where:

- S—Signed bit
- D—Data
- V—Volume padding

4.17.1.2 PCM Timing

The following table and drawings illustrate PCM signals timing when operating in PCM mode.

Table 4-20: PCM Mode Timing^a

Parameter	Description	Min	Typ	Max	Units
t(sync)	PCM_SYNC cycle time	-	125	-	μs
t(synch)	PCM_SYNC high time	-	488	-	ns
t(syncl)	PCM_SYNC low time	-	124.5	-	μs
t(clk)	PCM_CLK cycle time	-	488	-	ns
t(clkh)	PCM_CLK high time	-	244	-	ns
t(clkl)	PCM_CLK low time	-	244	-	ns
t(susync)	PCM_SYNC setup time high before falling edge of PCM_CLK	-	122	-	ns
t(sudin)	PCM_IN setup time before falling edge of PCM_CLK	60	-	-	ns
t(hdin)	PCM_IN hold time after falling edge of PCM_CLK	60	-	-	ns

Table 4-20: PCM Mode Timing^a (Continued)

Parameter	Description	Min	Typ	Max	Units
t(pdout)	Delay from PCM_CLK rising to PCM_OUT valid	-	-	60	ns
t(zdout)	Delay from PCM_CLK falling to PCM_OUT HIGH-Z	-	-	60	ns

a. Maximum PCM clock rate is 2.048 MHz.

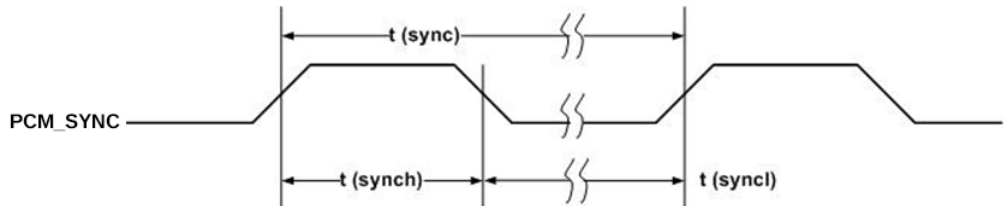


Figure 4-5: PCM_SYNC Timing Diagram (2048 kHz clock)

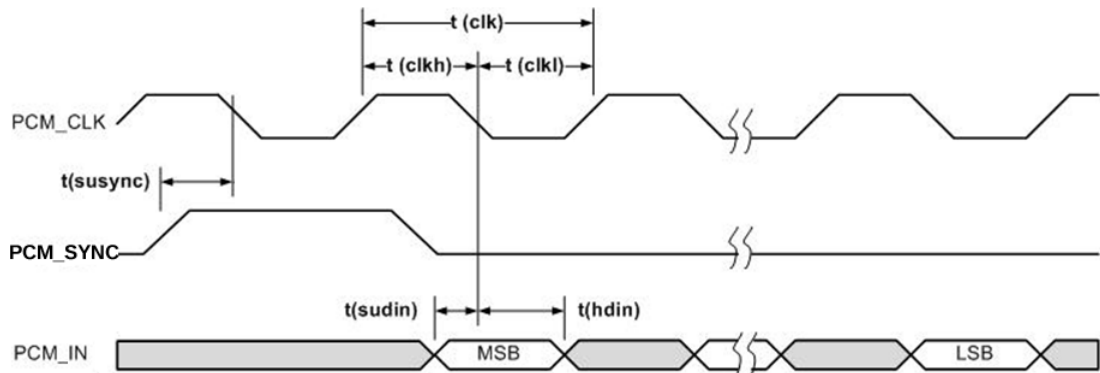


Figure 4-6: PCM Codec to Device Timing Diagram

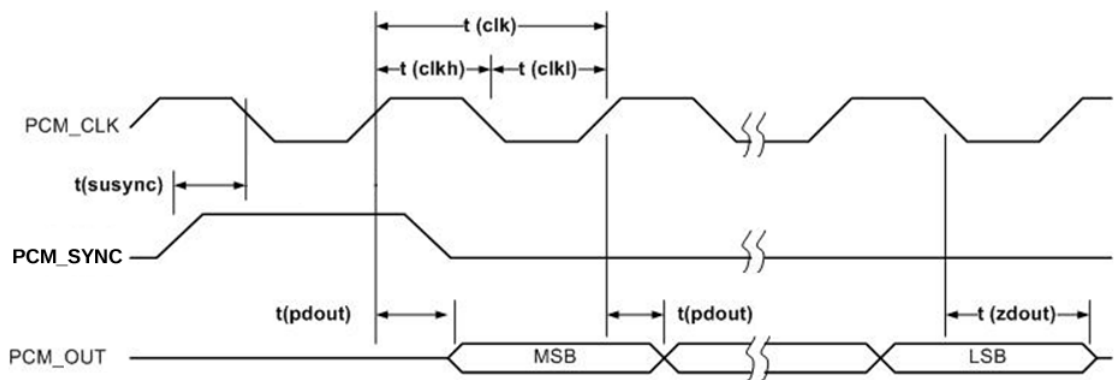


Figure 4-7: Device to PCM Codec Timing Diagram

4.17.2 I²S

The I²S interface can be used to transfer serial digital audio to or from an external stereo DAC/ADC and supports the following features:

- Mode: Master (Slave mode is not supported)
- Sampling rate: 48 kHz

- Bits per frame: 16
- Bit clock: 1536 kHz

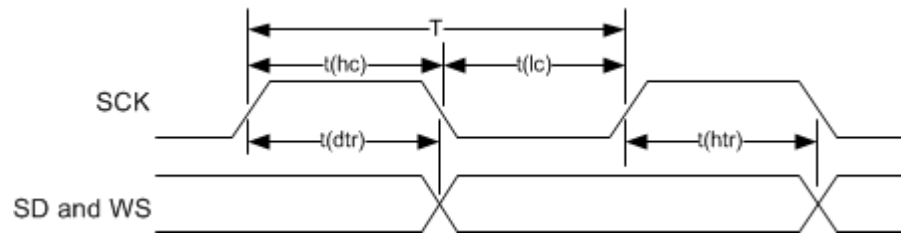


Figure 4-8: I²S Transmitter Timing

Table 4-21: Master Transmitter With Data Rate = 3.072 MHz (±10%)^a

Parameter	Description	Condition	Min	Typ	Max	Units
T	Clock period	I ² S requirement: min T=293	293	326	359	ns
t(hc)	Clock high	I ² S requirement: min > 0.35T	120	-	-	ns
t(lc)	Clock low	I ² S requirement: min > 0.35T	120	-	-	ns
t(dtr)	Delay	I ² S requirement: max < 0.8T	-	-	250	ns
t(htr)	Hold time	I ² S requirement: min > 0	100	-	-	ns

a. Maximum sample rate = 48 kHz at 3.072 MHz (16 bits per sample)

4.18 SPI Bus

The AirPrime WP75xx/AirPrime WP8548 module provides one 4-wire serial peripheral interfaces (SPI1).

The following features are available on the SPI bus:

- Mode: Master (Slave mode is not supported)
- SPI speeds: 960 kbps, 4 Mbps, 4.8 Mbps, 9.6 Mbps, 13 Mbps in master mode operation
- 4-wire interface
- 4 to 32 bits data length

[Table 4-22 on page 85](#) describes the SPI interface pins.

Table 4-22: SPI Pin Descriptions

Pin	Signal Name	Direction ^a	Description	Reset State	I/O Type
51	SPI1_MRDY	Output	SPI Master Ready	Z	1V8
52	SPI1_MISO	Input	SPI Master Input/Slave Output (output from slave)	Z	
53	SPI1_CLK	Output	SPI serial clock (output from Master)	Z	
54	SPI1_MOSI	Output	SPI Master Output/Slave Input (output from master)	Z	

a. Signal direction with respect to module. Examples: SPI1_MISO (pin 52) is an input to the module from the host; SPI1_CLK (pin 53) is an output from the module to the host.

4.18.1 SPI Configuration

Table 4-23: SPI Configuration

Operation	Max Speed	SPI-Mode	Duplex	4-wire Type
Master	26 Mb/s	0,1,2,3	Full	<ul style="list-style-type: none"> SCLK (SPI1_CLK) MOSI (SPI1_MOSI) MISO (SPI1_MISO) SS (SPI1_MRDY)

4.18.2 SPI Waveforms

The following figure shows waveforms for SPI transfer using a 4-wire configuration.

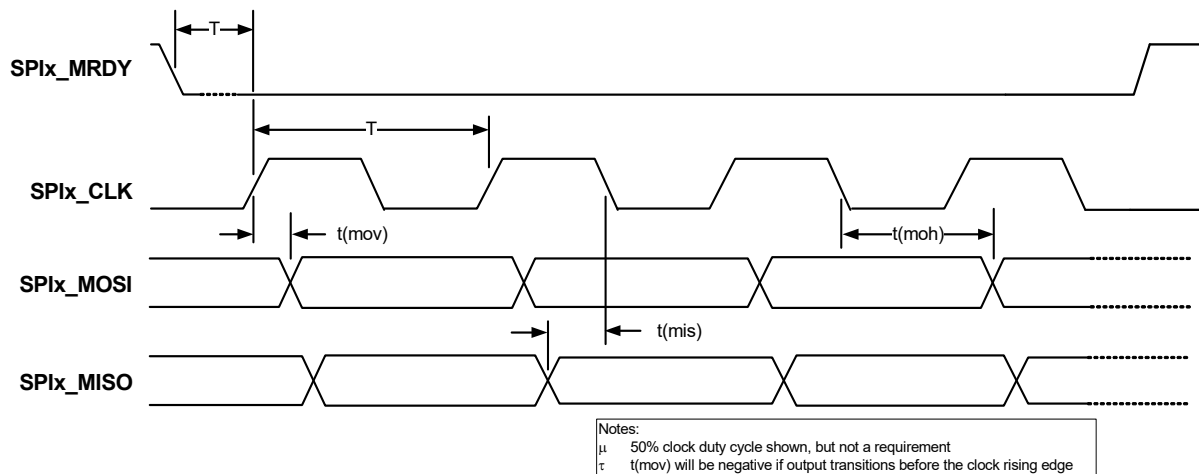


Figure 4-9: 4-Wire Configuration SPI Transfer

Table 4-24: SPI Master Timing Characteristics

Parameter		Min	Typ	Max	Unit
SPI clock frequency		0.96	-	26	MHz
T	SPI clock period	38	-	-	ns
t(ch)	Clock high	17	-	-	ns
t(cl)	Clock low	17	-	-	ns
t(mov)	Master output valid	-5	-	5	ns
t(mis)	Master input setup	3	-	-	ns
t(moh)	Master output hold	3	-	-	ns
t(tse)	Tri-state enable	-5	-	5	ns
t(tsd)	Tri-state disable	-5	-	5	ns

4.18.3 Application

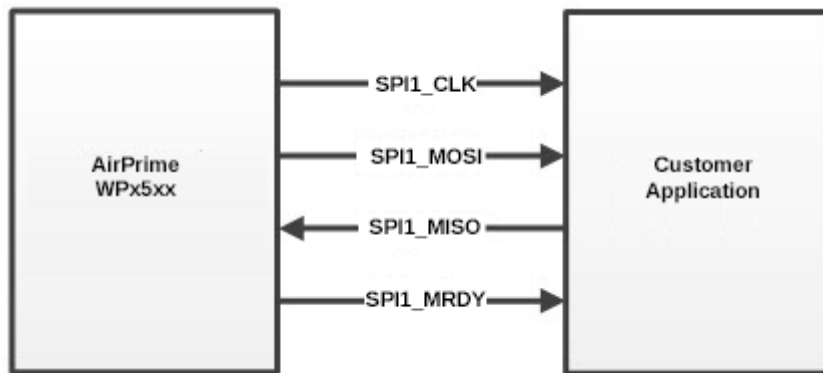


Figure 4-10: Example of 4-wire SPI Bus Application

4.19 HSIC Bus

The AirPrime WP75xx/AirPrime WP8548 module provides a 2-wire HSIC (High-Speed Inter-Chip) bus.

Table 4-25: HSIC Pin Descriptions

Pin	Signal Name ^a	Direction ^a	Description	Reset State	I/O Type
14	HSIC_DATA	I/O	HSIC data	Z	1V2
15	HSIC_STRB	I/O	HSIC strobe signal	Z	

a. From host view

4.19.1 HSIC Waveforms

Refer to [2] Inter-Chip USB Supplement to the USB 2.0 Specification Revision 1.0.

4.19.2 Application

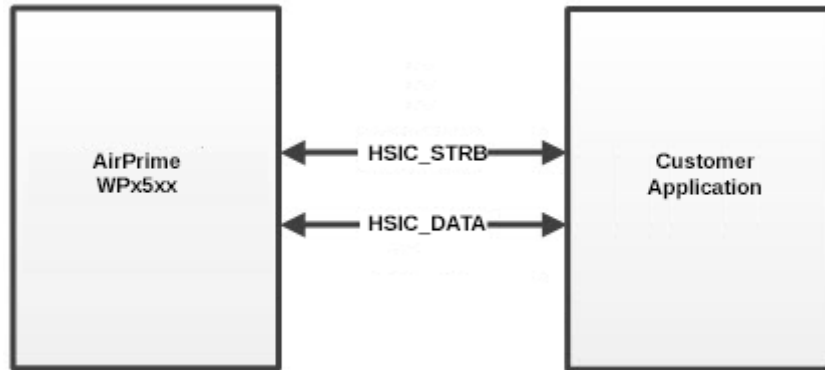


Figure 4-11: Example of 2-wire HSIC Bus Application

Application notes:

- Trace length < 10 cm
- Skew between data and strobe signals < 15 ps
- HSIC_DATA and HSIC_STRB should maintain a 50Ω impedance routing, and isolation between the lines should be maintained

4.20 Clock

The AirPrime WP75xx/AirPrime WP8548 module supports two digital clock interfaces that are connected directly from the PMIC.

Table 4-26 describes the clock interface pins.

Table 4-26: Clock Interface Pin Descriptions

Pin	Signal name	I/O	I/O type	Description	If Unused
22	SYS_CLK	Output	1.8V	19.2 MHz digital clock output	Leave open
23	SLEEP_CLK	Output	1.8V	32.768 kHz digital clock output	Leave open

4.21 TP1 (Boot Pin)

The TP1 pin (boot pin) can be used for two primary purposes:

- The pin can be used to force the module to enter boot-loader mode on power-up— Connect the pin to a control mechanism (for example, a button, switch, or jumper) on the host platform, and use this mechanism to assert (drive low) the TP1 pin on power-up. The boot loader monitors the TP1 pin and when it detects a low signal, prevents normal power-up and prepares to download firmware via the DM port.

When the module has restarted and entered boot-loader mode, make sure to de-assert the TP1 pin. When the firmware download finishes, the module reboots automatically and the de-asserted pin allows the module to boot normally.

- If not connected to a control mechanism, at minimum the pin should be connected to a test point on the host platform, for use by Sierra Wireless in RMA debugging.

Note: Firmware downloads also occur using software tools available on source.sierrawireless.com or over the air using an AirVantage server.

Table 4-27: TP1 Pin Description

Pin	Name	Direction	Function	If Unused
47	TP1	Input	Device recovery (boot load)	Mandatory test point

4.22 Temperature Monitoring

The AirPrime WP75xx/AirPrime WP8548 provides internal temperature monitoring of the module’s thermistor (located near the PA), as detailed below in Figure 4-12 and Table 4-28.

The temperature state can be queried directly, and unsolicited notifications of temperature state transitions can be received by using:

- AT!PATEMP—Display the current temperature state (normal, hi or low warning, hi or low critical).
- AT+WUSLMSK—Enable unsolicited notifications for !PATEMP, to be received over the AT port whenever the state changes.

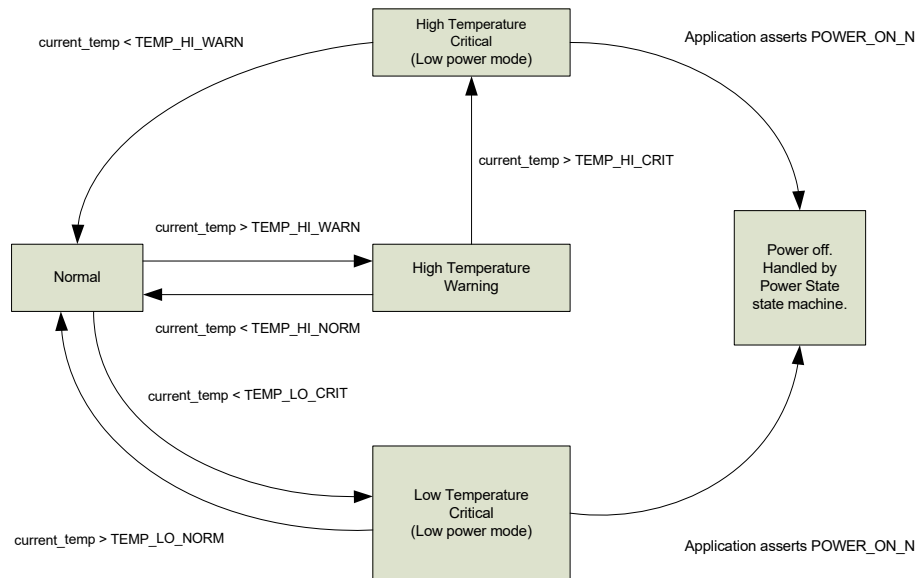


Figure 4-12: Temperature Monitoring State Machine

Table 4-28: Temperature Monitoring States

State	Description	Threshold	Default Temp value (C) ^a	Functionality
Normal	PA thermistor is between	TEMP_HI_NORM	+100	All
		TEMP_LO_NORM	-40	
High Temperature Warning	PA thermistor has exceeded	TEMP_HI_WARN	+110	All
High Temperature Critical	PA thermistor has exceeded	TEMP_HI_CRIT	+120	Low Power Mode
Low Temperature Critical	PA thermistor has descended past	TEMP_LO_CRIT	-45	Low Power Mode

a. Junction (PA thermistor) temperature

To restore full operation, the PA thermistor's temperature reading must be within the normal or high temperature warning state thresholds.

4.23 Test Pins

Sierra Wireless requires test points on the customer application for Sierra Wireless RMA and debug service.

Table 4-29: Test Pin Descriptions

Pin	Name	Function	If Unused
236	J1	Test point	Mandatory test point
237	J2	Test point	Mandatory test point
238	J3	Test point	Mandatory test point
239	J4	Test point	Mandatory test point
240	J5	Test point	Mandatory test point
241	J6	Test point	Mandatory test point
242	J7	Test point	Mandatory test point
243	J8	Test point	Mandatory test point
244	J9	Test point	Mandatory test point

4.24 Antenna Control

Note: Antenna control signals support is optional.

The AirPrime WP75xx/AirPrime WP8548 provides four output signals that can be used for host designs that incorporate tunable antennas.

Note: It is the responsibility of developers of host designs to evaluate the performance of tunable antennas that use these signals for neighbor cell measurements, Inter-RAT handovers, etc. Sierra Wireless does not guarantee ANT_CNTLx signal timing.

Note: These pins can be configured for use as GPIOs using +WIOCFG.

Table 4-30: Antenna Control Signals

Pin	Name	Direction ^a	Function	If Unused
153	ANT_CNTL0	Output	Customer-defined external switch control for tunable antennas	Leave open
154	ANT_CNTL1	Output		Leave open
155	ANT_CNTL2	Output		Leave open
156	ANT_CNTL3	Output		Leave open

a. Signal direction with respect to module. Examples: ANT_CNTL0 (pin 153) is an output from the module to the host.

To tune the antenna:

1. Enable band selection, which is required to tune the antennas for specific bands:
 - `AT!CUSTOM="BANDSELEN",1`

(Note: This setting is persistent unless disabled by issuing `AT!CUSTOM="BANDSELEN",0`.)
2. Drive the antenna control signals high or low, as required, for a specific band:
 - `AT!ANTSEL=<band>, <gpio1>, <gpio2>, <gpio3>[, <gpio4>]`

See [1] AirPrime WPx5/WP76xx/WP77xx AT Command Reference for details.
(Note: <gpio1>–<gpio4> correspond to ANT_CTRL0–ANTCTRL3.)

4.25 Indication Interfaces

The AirPrime WP75xx/AirPrime WP8548 module provides several indication interfaces that deliver notifications when specific events occur. These interfaces include:

- [Tx Activity Indicator \(TX_ON\) on page 91](#)
- [WWAN_LED_N on page 91](#)
- [WAKE_ON_WWAN on page 92](#)
- [Ring Indicator on page 92](#)
- [SAFE_PWR_REMOVE on page 92](#)
- [UIM1_DET/UIM2_DET on page 92](#)

4.25.1 Tx Activity Indicator (TX_ON)

The AirPrime WP75xx/AirPrime WP8548 module provides a digital output signal to indicate the occurrence of Tx activity.

Table 4-31: Tx Activity Indicator States

Pin	Signal name	Direction ^a	I/O type	Module state	Signal State
60	TX_ON	Output	1.8V	During Tx activity	High
				No Tx	Low

a. Signal direction with respect to module—TX_ON (pin 60) is an output from the module to the host.

4.25.2 WWAN_LED_N

The AirPrime WP75xx/AirPrime WP8548 provides an LED control output signal pad. This signal is an open drain output.

Table 4-32: LED Interface Pin

Pin	Signal name	Direction ^a	Voltage / Current	Function	If Unused
106	WWAN_LED_N	Output	<ul style="list-style-type: none"> Voltage (max)=VBAT_BB + 0.5 V Maximum current sink capability=300 mA 	LED driver control	Leave open

a. Signal direction with respect to module—WWAN_LED_N (pin 106) is an output from the module to the host.

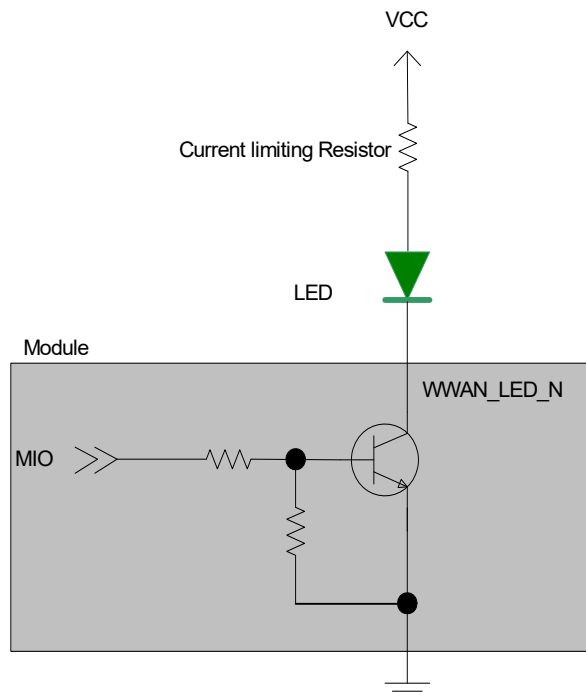


Figure 4-13: LED Reference Circuit

4.25.3 WAKE_ON_WWAN

Note: Host support for WAKE_ON_WWAN signal is optional.

The AirPrime WP75xx/AirPrime WP8548 drives WAKE_ON_WWAN high to wake the host when specific events occur.

See [Figure 4-14](#) for a recommended implementation.

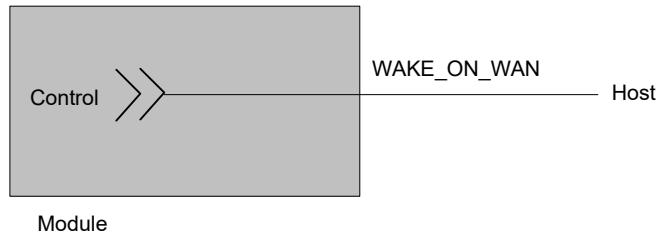


Figure 4-14: Recommended WAKE_ON_WWAN Connection

4.25.4 Ring Indicator

The ring indicator (UART1_RI) may be used to notify an external application of several events such as an incoming call, timer expiration, or incoming SMS. The AirPrime WP75xx/AirPrime WP8548 pulses the signal high when an event occurs.

Table 4-33: UART1_RI Pin

Pin	Name	Direction ^a	Function	If unused
2	UART1_RI	Output	Ring Indicator Signal incoming calls (voice and data), SMS, etc.	Leave open

a. Signal direction with respect to the module—UART1_RI (pin 2) is an output from the module to the host.

For additional details, refer to the Legato API documentation for Legato.io.

4.25.5 SAFE_PWR_REMOVE

The SAFE_PWR_REMOVE signal is used by the AirPrime WP75xx/AirPrime WP8548 to indicate to the host device that VBAT_BB/VBAT_RF can be removed. The signal is driven high when it is safe to remove the power supply.

REV12For timing details, refer to [Figure 4-1 on page 70](#).

4.25.6 UIM1_DET/UIM2_DET

The UIM Detect signals (UIM1_DET, UIM2_DET) are used to detect the physical presence of UIM cards in the UIM holders. Each UIM Detect signal has a pull-up internal to the AirPrime WP75xx/AirPrime WP8548. It should be set to GND when a UIM is not present. All signals near the UIM holder must be ESD-protected.

The UIM Detect signals transition:

- When a UIM is inserted—high (logic 0 to logic 1)
- When a UIM is removed—low (logic 1 to logic 0)

4.26 DR_SYNC

The AirPrime WP75xx/AirPrime WP8548 provides DR_SYNC, an output used for GPS dead reckoning synchronization.

The module pulses the DR_SYNC signal once every integer GPS second. While position fixes are occurring, the DR_SYNC pulse is aligned precisely with the GPS time. When a position fix cannot be made (for example, when a vehicle has entered a tunnel), the module continues to pulse the DR_SYNC signal every second while the level of uncertainty of the GPS time is low. When the uncertainty level is high, the module stops pulsing the signal.

Table 4-34: DR_SYNC Pin Details

Pin	Signal name	Direction ^a	Function	If Unused
42	DR_SYNC	Output	GPS dead reckoning sync signal	Leave open

a. Signal direction with respect to the module—DR_SYNC (pin 42) is an output from the module to the host.

4.27 W_DISABLE_N—Wireless Disable

Note: Host support for wireless disable signals is optional.

The host device uses W_DISABLE_N (pin 151) to enable / disable the WWAN or radio modem. When disabled, the modem cannot transmit or receive information.

Letting this signal float high allows the module to operate normally. The pin has an internal pull-up resistor. See [Figure 4-15](#) for a recommended implementation.

When integrating with your host device, keep the following in mind:

- The signal is an input to the module and should be driven LOW only for its active state (controlling the power state); otherwise it should be floating or (High impedance). It should never be driven to a logic high level. The module has an internal pull-up resistor to an internal 1.8V rail, so if the signal is floating or (high impedance), then the radio is on.
- If the host never needs to assert this power state control to the module, leave this signal unconnected from the host interface.

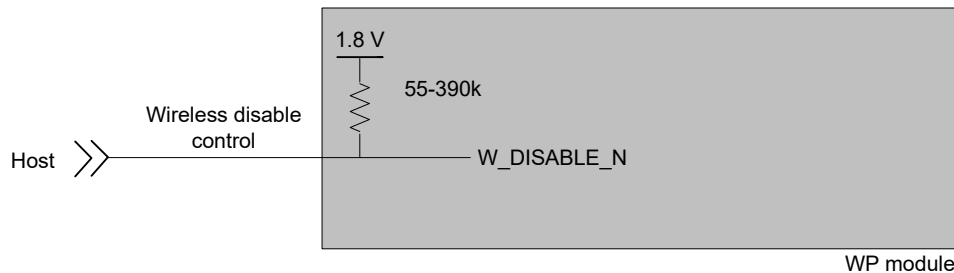


Figure 4-15: Recommended Wireless Disable Connection

>> 5: Routing Constraints and Recommendations

This section describes general routing constraints and recommendations for the AirPrime WP75xx/AirPrime WP8548 module.

Note: This is a non-exhaustive list of suggested design guidelines. The developer is responsible for deciding whether to implement these guidelines.

5.1 General Rules and Recommendations

Clock and other high-frequency digital signals (e.g. serial buses) should be routed as far as possible from the module's analog signals.

If the application design makes it possible, all analog signals should be separated from digital signals by a ground trace on the PCB.

Tip: Avoid routing any signals under the module on the application board.

5.2 PCB Layout Recommendations

Ground pads should be re-flowed on to the host PCB with < 30% voiding to allow effective heat dissipation.

5.3 Power Supply

When designing the power supply, make sure that VBAT_BB/VBAT_RF meet the requirements listed in [Power Supply Ratings on page 35](#).

Careful attention should be paid to the following:

- Power supply quality—PFM, or PSM systems should be avoided; Low ripple, linear regulation or PWM converters are preferred for low noise.
- Capacity to deliver high current peaks in a short time (for pulsed radio emission)
- VBAT_BB/VBAT_RF must support peak currents with an acceptable voltage drop that guarantees the minimum required VBAT_BB/VBAT_RF value.
- VBAT_BB/VBAT_RF signal pads must never exceed the maximum required VBAT_BB/VBAT_RF value, otherwise the module's power amplifier and GPS chipset may be severely damaged.
- A weakly-designed (not robust) power supply could affect EMC performance, the emission spectrum, and the phase error and frequency error.

5.4 Antenna

Sierra Wireless strongly recommends working with an antenna manufacturer either to develop an antenna adapted to the application, or to adapt an existing solution to the application.

For information on routing constraints for the RF circuit, see [RF Circuit on page 96](#).

5.5 PCB Specifications for the Application Board

Sensitive signals (such as audio, UIM, and clocks) should be protected by ground planes/fills. Routing sensitive signals close to noisy signals could result in noise being coupled.

5.6 Recommended PCB Land Pattern

Refer to the AirPrime WP75xx/AirPrime WP8548 Customer Process Guidelines document, available at <http://source.sierrawireless.com>.

5.7 Routing Constraints

5.7.1 Power Supply

If the following design recommendations are not followed, phase error (peak) and power loss could occur.

Note: The recommended power supply capacity (Table 3-4 on page 36) is greater than the maximum peak current to provide an operating margin.

- Since the maximum peak current can reach 2.5 A, Sierra Wireless strongly recommends having a large width for the layout of the power supply signal (to avoid voltage loss between the external power supply and VBAT_BB/VBAT_RF).

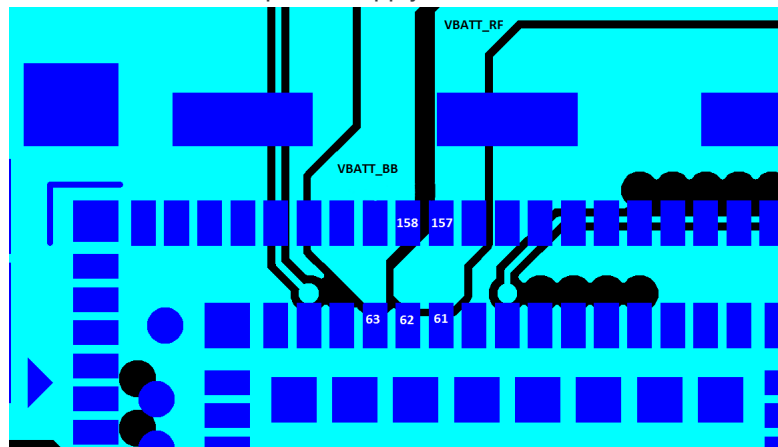


Figure 5-1: Power Supply Routing Example

Note: Figure 5-1 shows separate traces for VBAT_BB and VBAT_RF. If VBAT_BB and VBAT_RF share a single power supply, these traces should be connected.

Note: For optimal decoupling, place the capacitors on the underside of the board, directly under the pins.

- Filtering capacitors (100 nF to 1500 μ F) are recommended near the module's power supply.
- Attention should be paid to the ground trace or the ground plane on the application board for the power supply that supplies the module. The ground trace or ground plane, as well as the VBAT trace, must be able to support current peaks.
- If the ground trace between the module and the power supply is a copper plane, make sure it is a solid plane.
- Design routing to make sure total line impedance does not exceed 10 m Ω @ 217 Hz.

5.7.1.1 Ground Plane Connection

The AirPrime WP75xx/AirPrime WP8548 module requires a solid, central ground plane (with solder mask defined pads) located directly under the module. This will:

- Ensure high current signal returns
- Provide heat dissipation under higher operating temperatures

The ground plane should be connected (with vias) to the reference ground layer of the application board.

5.7.2 UIM Interface

- The length of the tracks between the AirPrime WP75xx/AirPrime WP8548 and the UIM socket should be as short as possible. Maximum recommended length is 10cm.
- ESD protection is mandatory on the UIM lines unless:
 - (WP8548 only) An ESIM is being used, or
 - There is no physical access to the UIM
- The decoupling capacitor(s) should be placed as close as possible to the UIM card connector for the UIM1_VCC signal.

5.7.3 RF Circuit

The RF signal must be routed on the application board using tracks with a 50 Ω characteristic impedance.

The characteristic impedance depends on the dielectric, the track width and the ground plane spacing.

It is recommended to use stripline design if the RF path is fairly long (more than 3cm), since microstrip design is not shielded. Consequently, the RF (transmit) signal may interfere with neighboring electronic circuits. In the same way, the neighboring electronics (micro-controllers, etc.) may interfere with the RF (receive) signal and degrade the reception performance.

The RF trace on the development board is routed from the AirPrime WP75xx/AirPrime WP8548 antenna port to the RF connector (IPEX MHF-4). The RF trace is designed as a 50 Ω coplanar stripline and its length is 20.7 mm.

The following drawings show the location of the AirPrime WP75xx/AirPrime WP8548 on the development board, the routing cross-section, and the top view of the RF trace on the development board.

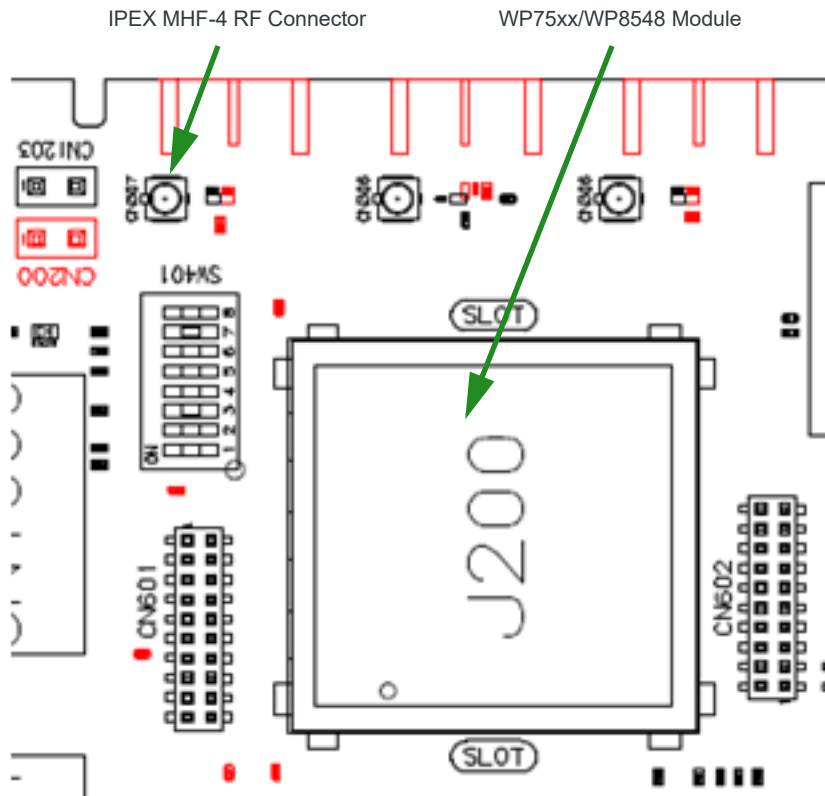


Figure 5-2: Module Location on Development Board

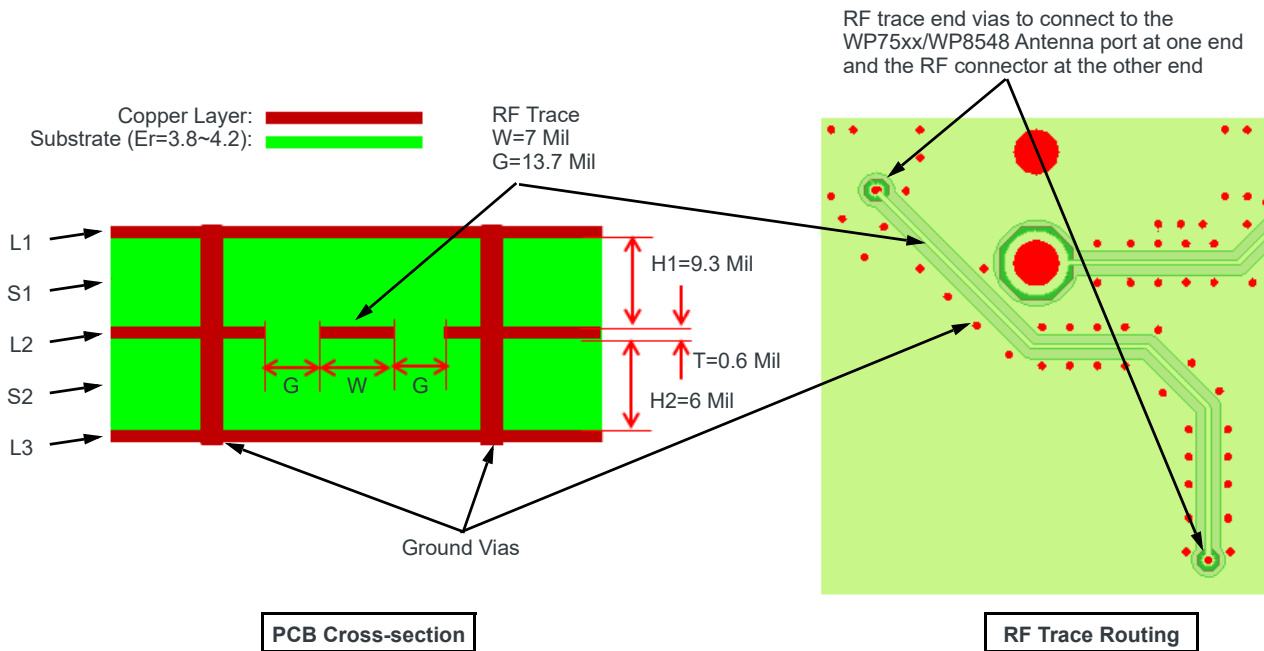


Figure 5-3: Development Board RF Trace Design

5.7.4 USB Interface

When the USB interface is externally accessible, ESD protection is required on the USB_VBUS, USB_D+, and USB_D- signals.

5.8 Thermal Considerations

When transmitting, the AirPrime WP75xx/AirPrime WP8548 can generate significant amounts of heat (due to the internal Power Amplifier) that must be dissipated in the host device for safety and performance reasons.

The amount of thermal dissipation required depends on the following factors:

- Supply voltage—Maximum power dissipation for these modules can be up to 3 W at voltage supply limits.
- Usage—Typical power dissipation values depend on the location within the host, amount of data transferred, etc.

To enhance heat dissipation:

- Maximize airflow over / around the module
- Locate the module away from other components that generate heat
- Ensure the module is connected to a solid ground plane

5.9 EMC and ESD Recommendations

EMC tests must be performed on the application as soon as possible to detect any potential problems.

When designing, special attention should be paid to:

- Possible spurious emissions radiated by the application to the RF receiver in the receiver band
- ESD protection—Typically, ESD protection is mandatory for externally accessible signals, including:
 - VBAT_RF/VBAT_BB
 - UIM (if accessible from outside)
 - Serial link
 - USB
 - Antennas
- Length of the UIM interface lines (preferably <10 cm)
- Length of the HSIC interface lines (<10 cm, as required by the HSIC specification)
- EMC protection on audio input/output (filters against 900 MHz emissions)
- Ground plane: Sierra Wireless recommends a common ground plane for analog/digital/RF grounds

Note: The AirPrime WP75xx/AirPrime WP8548 does not include any protection against over-voltage.

The host device must provide adequate ESD protection on digital circuits and antenna ports as detailed in the following table.

Note: The level of protection required depends on your application.

Table 5-1: ESD Specifications ^{a,b}

Category	Connection	Specification
Operational	<ul style="list-style-type: none"> • RF ports • UIM connector • USB connector • UART connector 	IEC-61000-4-2 - Level (Electrostatic Discharge Immunity Test) <ul style="list-style-type: none"> • ± 6kV Contact • ± 8kV Air
Non-operational	Host connector interface	Unless otherwise specified: <ul style="list-style-type: none"> • JESD22-A114 ± 1kV Human Body Model • JESD22-A115 ± 100V Machine Model • JESD22-C101C ± 500V Charged Device Model

- a. ESD specifications are preliminary, subject to change.
 b. ESD protection is highly recommended at the point where the UIM contacts are exposed, and for any other signals that would be subjected to ESD by the user.

5.10 Mechanical Integration

Attention should be paid to:

- Antenna cable integration (bending, length, position, etc)
- Pads of the AirPrime WP75xx/AirPrime WP8548 to be soldered to the ground plane
- Ensuring proper board layout
- Providing sufficient space around the module for heat dissipation

5.11 Signal Reference Schematics

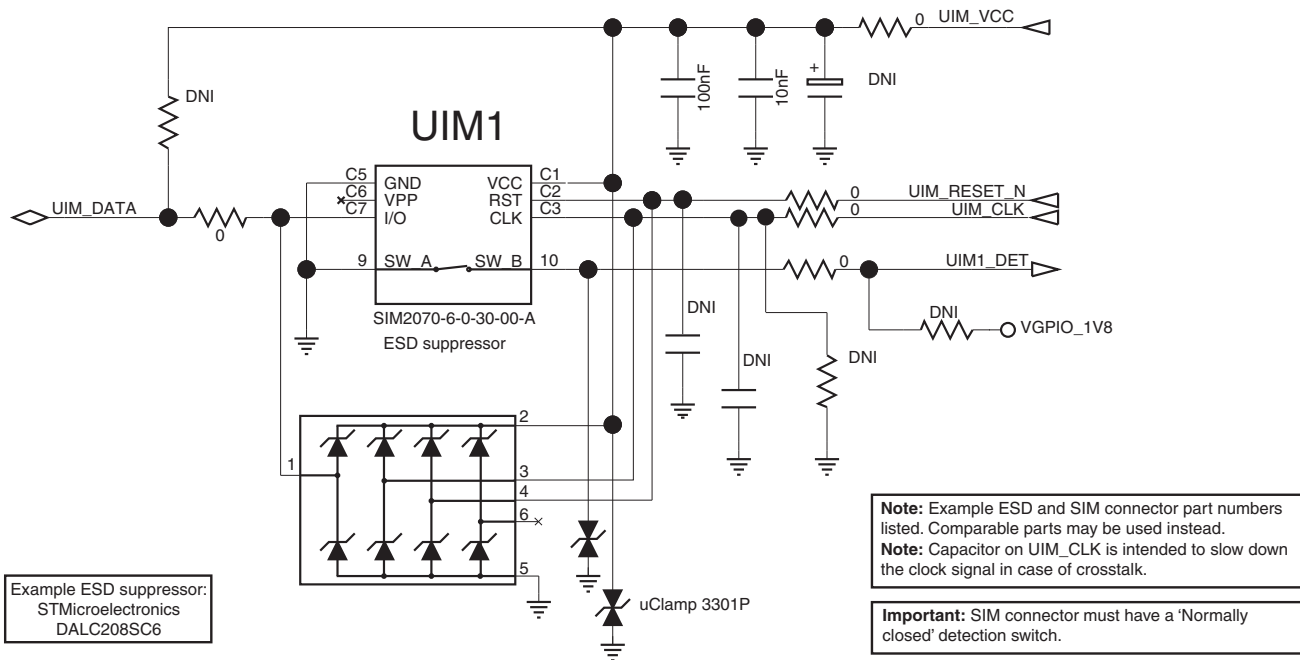


Figure 5-4: UIM Interface

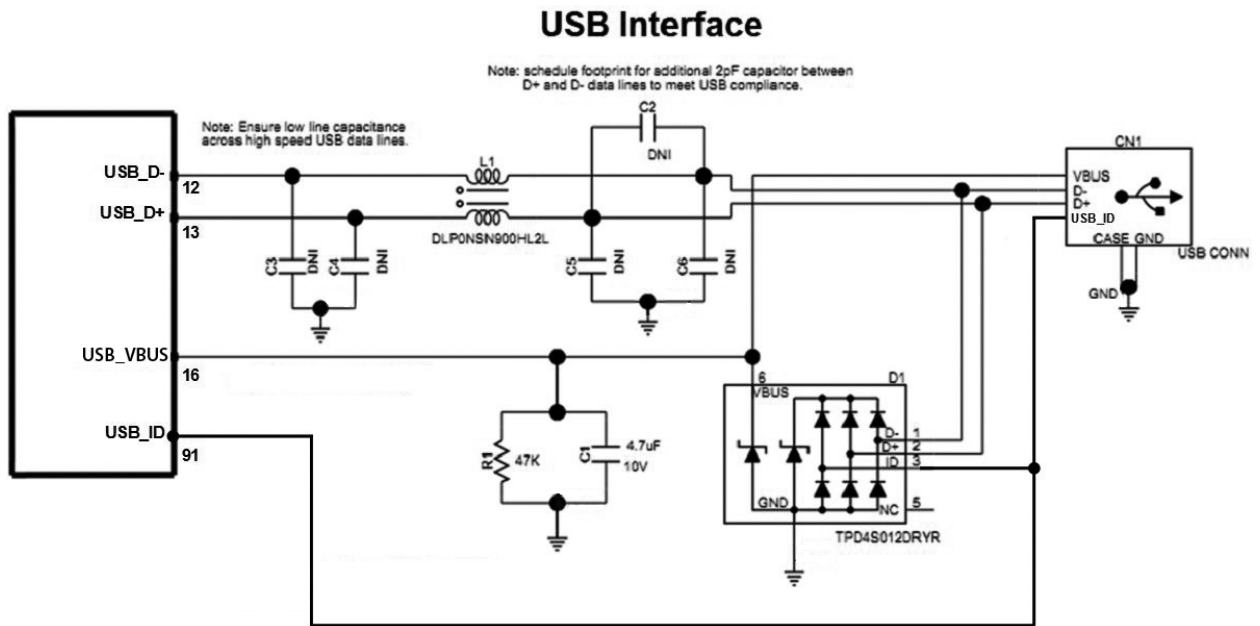


Figure 5-5: USB Interface

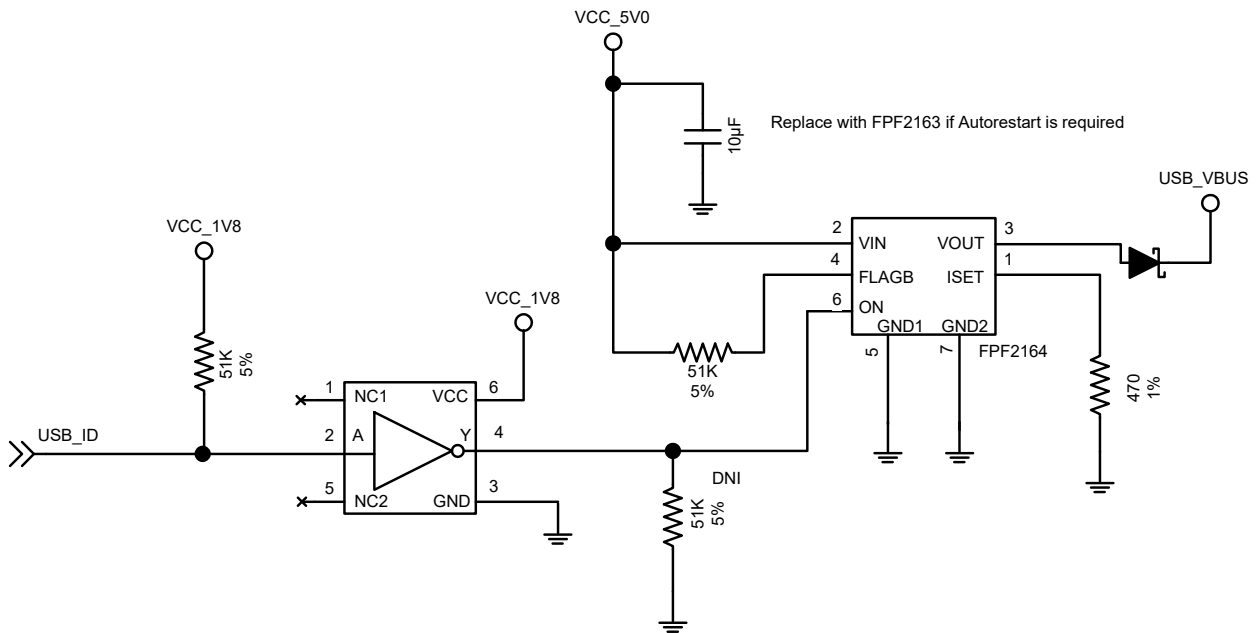


Figure 5-6: USB OTG Interface

>> 6: Software and Tools

6.1 Support Tools

The AirPrime WP75xx/AirPrime WP8548 is compatible with Sierra Wireless' SwiLogPlus trace tool that allows users to send error logs to Sierra Wireless.

6.2 SED (Smart Error Detection)

The AirPrime WP75xx/AirPrime WP8548 uses a form of SED to track unexpected/spontaneous module resets (resets that are not deliberately initiated). In such cases, the module automatically forces a pause in boot-and-hold mode at power-on to accept an expected firmware download to resolve the problem.

1. Module tracks consecutive unexpected/spontaneous resets within 30 seconds of power-on.
2. After a sixth consecutive unexpected/spontaneous reset, the module waits in boot-and-hold mode (up to 30 seconds) for a firmware download to resolve the power-cycle problem.

A RAM dump tool that can be used to help isolate the cause of unexpected/spontaneous resets is available from Sierra Wireless. Contact your Sierra Wireless account representative for assistance.

6.3 Firmware Upgrade

Firmware upgrades are downloaded to the embedded module over the USB interface or over the air via Sierra Wireless' AVMS (AirVantage Management System). Contact your Sierra Wireless account representative for assistance.

6.4 Operating System Upgrade

The AirPrime WP75xx/AirPrime WP8548 module's operating system is stored in flash memory and can be easily upgraded.

Tip: *To follow regular changes in the 3GPP standard and to offer a state-of-the-art operating system, Sierra Wireless recommends that the application designed around an embedded module (or embedded module based product) should allow easy operating system upgrades on the embedded module via the recommended firmware download protocol. Therefore, the application shall either allow a direct access to the embedded module USB interface through an external connector or implement any mechanism allowing the embedded module operating system to be downloaded.*

6.5 Labeling

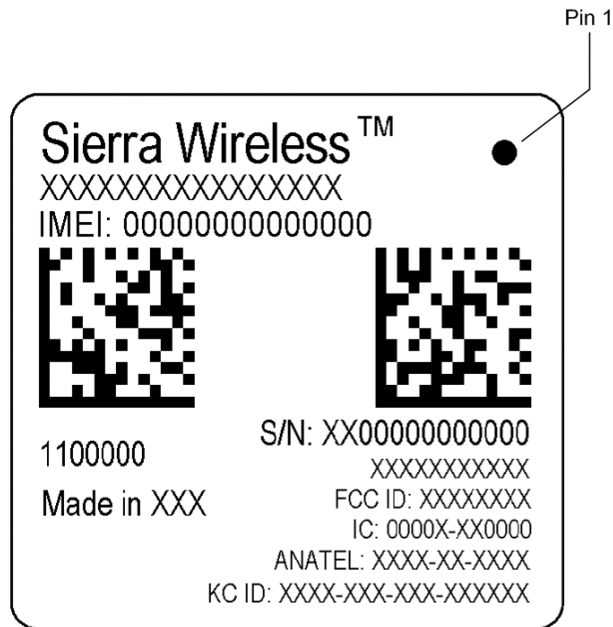


Figure 6-1: Unit Label Example (Contents will vary by SKU)

The AirPrime WP75xx/AirPrime WP8548 label is non-removable and may contain:

- Product identification (Model name, serial number)
- IMEI or MEID number and barcode
- Fabrication country
- Required regulatory markings (FCC ID, IC certification number, etc., as appropriate)
- Pin 1 indicator

Note: The AirPrime WP75xx/AirPrime WP8548 supports OEM partner specific label requirements.

>> 7: Debug and Assembly Considerations

7.1 Testing Assistance Provided by Sierra Wireless

Sierra Wireless offers optional professional services based assistance to OEMs with regulatory approvals.

7.2 Integration Requirements

When integrating the AirPrime WP75xx/AirPrime WP8548 module, the following items must be addressed:

- Mounting—Effect on temperature, shock, and vibration performance
- Power supply—Impact on battery drain and possible RF interference
- Antenna location and type—Impact on RF performance
- Regulatory approvals—As discussed in [Approval on page 113](#)
- Service provisioning—Manufacturing process

Sierra Wireless provides guidelines for successful AirPrime WP75xx/AirPrime WP8548 module integration with the document suite and offers integration support services as necessary.

7.3 IOT/Operator

Interoperability and Operator/Carrier testing of the finished system is the responsibility of the OEM. The test process will be determined with the chosen network operator(s) and will be dependent upon your business relationship with them, as well as the product's application and sales channel strategy.

Sierra Wireless offers assistance to OEMs with the testing process, if required.

7.4 Module Testing Recommendations

When testing your integration design:

- Test to your worst case operating environment conditions (temperature and voltage)
- Test using worst case operation (transmitter on 100% duty cycle, maximum power)
- Monitor the module's junction temperature using AT!PATEMP. This command polls the module's thermistor (located near the power amplifier, typically the hottest spot on the module).

Note: Make sure that your system design provides sufficient cooling for the integrated module. The RF shield temperature should not be exposed to an ambient temperature greater than 85 °C to prevent damage to the module's components.

7.5 Serial Link Access

Direct access to the UART1/UART2 serial link is very useful for:

- Testability operations
- Accessing the module’s Linux console for debugging

Refer to the following figure for a level shifter implementation that allows UART1 serial link access. (A UART2 (2-wire interface) level shifter would use the corresponding WP75xx/ WP8548 UART2 pins—UART2_TX (pin 96), UART2_RX (pin 97).)

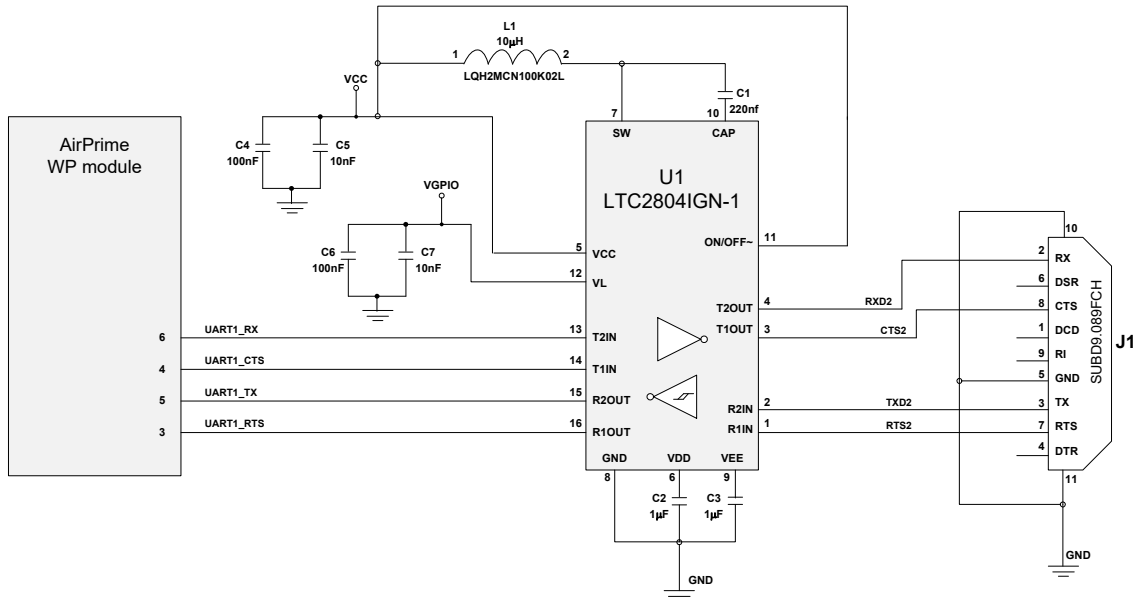


Figure 7-1: Level Shifter Implementation for UART1 Serial Link Access

7.6 RF Output Accessibility

During the integration phase of the AirPrime WP75xx/AirPrime WP8548, it can be helpful to connect the module to a simulator to check critical RF TX parameters and power behavior for supported RATs (LTE (WP75xx), WCDMA, HSDPA, HSUPA, CDMA (WP7504), and GSM/EDGE/GPRS (WP7502/WP8548)).

Although the AirPrime WP75xx/AirPrime WP8548 module has been certified, some parameters may have degraded if some basic precautions have not been followed (poor power supply, for example). This may not affect the functionality of the product, but the product may not comply with 3GPP specifications.

The following TX parameters can be checked using a Radio Communication tester:

- Phase & Frequency Error
- Output Power and Burst Time
- Output Spectrum (Modulation and Switching)

The following are available typical Radio Communication testers:

- Rohde & Schwarz: CMU200, CMW500
- Keysight (formerly Agilent): 8960
- Anritsu: MD8475

Because of the high prices associated with Radio Communication testers and the necessary RF know-how to perform simulations, customers can check their applications in the Sierra Wireless laboratories. Contact the Sierra Wireless support team for more information.

>> 8: Reliability Specification

AirPrime WP75xx/AirPrime WP8548 modules are tested against the Sierra Wireless Industrial Reliability Specification defined below.

8.1 Reliability Compliance

AirPrime WP75xx/AirPrime WP8548 modules connected on a reliability test board are compliant with the requirements in [Table 8-1](#).

Table 8-1: Standards Conformity


Abbreviation	Definition
IEC	International Electrotechnical Commission
ISO	International Organization for Standardization

8.2 Reliability Prediction Model

8.2.1 Life Stress Test

The following tests the AirPrime WP75xx/AirPrime WP8548 module's product performance.

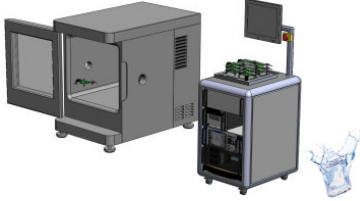
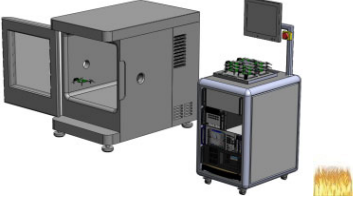
Table 8-2: Life Stress Test

Designation	Condition
Performance Test PT3T & PTRT 	Standard: N/A
	Special conditions: <ul style="list-style-type: none"> • Temperature: <ul style="list-style-type: none"> • Class A: -30°C to +70°C • Class B: -40°C to +85°C • Rate of temperature change: $3 \pm 0.6^\circ\text{C}/\text{min}$ • Recovery time: 3 hours
	Operating conditions: Powered
	Duration: 14 days

8.2.2 Environmental Resistance Stress Tests

The following tests the AirPrime WP75xx/AirPrime WP8548 module's resistance to extreme temperature.

Table 8-3: Environmental Resistance Stress Tests

Designation	Condition
Cold Test Active COTA 	Standard: IEC 680068-2-1, Test ad
	Special conditions: <ul style="list-style-type: none"> • Temperature: -40°C • Temperature variation: 1°C/min
	Operating conditions: Powered ON with a power cycle of 1 minute ON and 2 minutes OFF
	Duration: 3 days
Resistance to Heat Test RH 	Standard: IEC 680068-2-2, Test Bb
	Special conditions: <ul style="list-style-type: none"> • Temperature: +85°C • Temperature variation: 1°C/min
	Operating conditions: Powered ON with a power cycle of 15 minutes ON and 15 minutes OFF
	Duration: 50 days

8.2.3 Corrosive Resistance Stress Tests

The following tests the AirPrime WP75xx/AirPrime WP8548 module's resistance to corrosive atmosphere.

Table 8-4: Corrosive Resistance Stress Tests



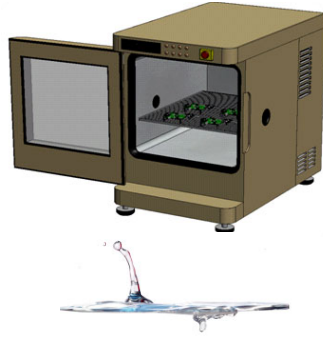
Designation	Condition
Humidity Test HUT 	Standard: IEC 60068-2-3, Test Ca
	Special conditions: <ul style="list-style-type: none"> • Temperature: +65°C • RH: 95% • Temperature variation: $3 \pm 0.6^\circ\text{C}/\text{min}$
	Operating conditions: Powered ON with a power cycle of 15 minutes ON and 15 minutes OFF
	Duration: 10 days

Table 8-4: Corrosive Resistance Stress Tests (Continued)

Designation	Condition
Component Solder Wettability CSW 	Standard: JESD22-B102, Method 1/Condition C, Solderability Test Method Special conditions: <ul style="list-style-type: none"> • Test method: Dip and Look Test with Steam preconditioning 8 h ± 15 min. Dip for 5 +0/-0.5 seconds Operating conditions: Unpowered Duration: 1 day
Moist Heat Cyclic Test MHCT 	Standard: IEC 60068-2-30, Test Db Special conditions: <ul style="list-style-type: none"> • Upper temperature: +40 ± 2°C • Lower temperature: +23 ± 5°C • RH: <ul style="list-style-type: none"> • At upper temperature: 93% • At lower temperature: 95% • Number of cycles: 21 (1 cycle/24 hours) • Temperature variation: 3 ± 0.6°C/min Operating conditions: Powered ON for 15 minutes during each 3 hours ramp up and 3 hours ramp down (in middle) for every cycle Duration: 21 days

8.2.4 Thermal Resistance Cycle Stress Tests

The following tests the AirPrime WP75xx/AirPrime WP8548 module's resistance to extreme temperature cycling.

Table 8-5: Thermal Resistance Cycle Stress Tests


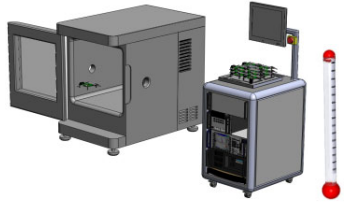
Designation	Condition
Thermal Shock Test TSKT 	Standard: IEC 60068-2-14, Test Na Special conditions: <ul style="list-style-type: none"> • Temperature: -30°C to +80°C • Temperature variation: 6–30 s • Number of cycles: 600 • Dwell time: 10 minutes Operating conditions: Unpowered Duration: 9 days

Table 8-5: Thermal Resistance Cycle Stress Tests (Continued)

Designation	Condition
Temperature Change TCH 	Standard: IEC 60068-2-14, Test Nb
	Special conditions: Temperature: -40°C to +90°C Temperature variation: 3 ± 0.6°C/min Number of cycles: 400 Dwell time: 10 minutes
	Operating conditions: Unpowered
	Duration: 29 days

8.2.5 Mechanical Resistance Stress Tests

The following tests the AirPrime WP75xx/AirPrime WP8548 module's resistance to vibrations and mechanical shocks.

Table 8-6: Mechanical Resistance Stress Tests

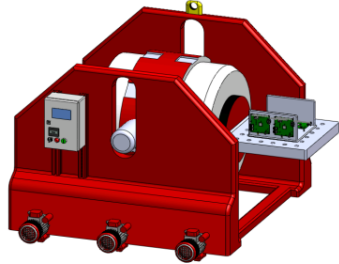
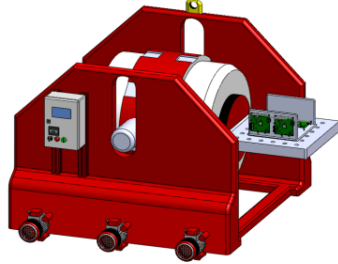
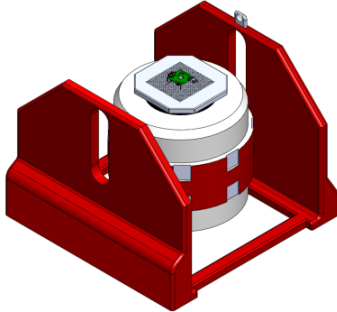
Designation	Condition
Sinusoidal Vibration Test SVT 	Standard: IEC 60068-2-6, Test Fc
	Special conditions: <ul style="list-style-type: none"> • Frequency range: 16 Hz to 1000 Hz • Displacement: 0.35 mm (peak-peak) • Acceleration: <ul style="list-style-type: none"> • 5 g from 16 to 62 Hz • 3 g from 62 to 200 Hz • 1 g from 200 to 1000 Hz • Sweep rate: 1 octave/minute • Number of sweeps: 20 sweeps/axis • Sweep direction: ± X, ± Y, ± Z
	Operating conditions: Unpowered
	Duration: 2 days

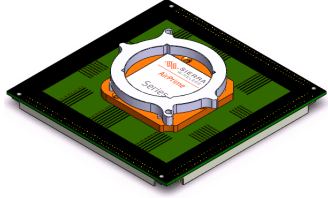

Table 8-6: Mechanical Resistance Stress Tests (Continued)

Designation	Condition
Random Vibration Test RVT 	Standard: IEC 60068-2-64, Test Fh Special conditions: <ul style="list-style-type: none"> • Frequency range: 10 Hz to 2000 Hz • Power Spectral Density in $[(m/s^2)^2/Hz]$ <ul style="list-style-type: none"> • 0.1 g^2/Hz at 10 Hz • 0.01 g^2/Hz at 250 Hz • 0.005 g^2/Hz at 1000 Hz • 0.005 g^2/Hz at 2000 Hz • Peak factor: 3 • Duration per axis: 1 hr/axis Operating conditions: Unpowered Duration: 1 day
Mechanical Shock Test MST 	Standard: IEC 60068-2-27, Test Ea Special conditions: <ul style="list-style-type: none"> • Shock Test 1: <ul style="list-style-type: none"> • Wave form: Half sine • Peak acceleration: 30 g • Duration: 11 ms • Number of shocks: 8 • Direction: $\pm X, \pm Y, \pm Z$ • Shock Test 2: <ul style="list-style-type: none"> • Wave form: Half sine • Peak acceleration: 100 g • Duration: 6 ms • Number of shocks: 3 • Direction: $\pm X, \pm Y, \pm Z$ Operating conditions: Unpowered Duration: 72 hours

8.2.6 Handling Resistance Stress Tests

The following tests the AirPrime WP75xx/AirPrime WP8548 module's resistance to handling malfunctions and damage.

Table 8-7: Handling Resistance Stress Tests

Designation	Condition
<p>ESDC Test</p> 	<p>Standard: JESD22-A114, JESD22-A115, JESD22-C101</p> <p>Special conditions:</p> <ul style="list-style-type: none"> • HBM (Human Body Model): 1 KV (Class 1C) • MM (Machine Model): 100 V • CDM (Charged Device Model): 500 V (Class IV) <p>Operating conditions: Powered</p> <p>Duration: 3 days</p>
<p>Free Fall Test FFT 1</p> 	<p>Standard: IEC 60068-2-32, Test Ed</p> <p>Special conditions:</p> <ul style="list-style-type: none"> • Number of drops: 2 drops per unit • Height: 1 m <p>Operating conditions: Unpowered</p> <p>Duration: 6 hours</p>

>> 9: Approval

9.1 RoHS Directive Compliance

The AirPrime WP75xx/AirPrime WP8548 module complies with the European Union's requirements on the restriction of the use of certain hazardous substances in electrical and electronic equipment—RoHS Directive 2011/65/EU, including Commission Delegated Directive (EU) 2015/863 amending Annex II of Directive 2011/65/EU.

9.2 Disposing of the Product

This electronic product is subject to the EU Directive 2012/19/EU for Waste Electrical and Electronic Equipment (WEEE). As such, this product must not be disposed of at a municipal waste collection point. Please refer to local regulations for directions on how to dispose of this product in an environmental friendly manner.

9.3 Important Notice

Due to the nature of wireless communications, transmission and reception of data can never be guaranteed. Data may be delayed, corrupted (i.e., have errors) or be totally lost. Although significant delays or losses of data are rare when wireless devices such as the Sierra Wireless modem are used in a normal manner with a well-constructed network, the Sierra Wireless modem should not be used in situations where failure to transmit or receive data could result in damage of any kind to the user or any other party, including but not limited to personal injury, death, or loss of property. Sierra Wireless accepts no responsibility for damages of any kind resulting from delays or errors in data transmitted or received using the Sierra Wireless modem, or for failure of the Sierra Wireless modem to transmit or receive such data.

9.4 Safety and Hazards

Do not operate your AirPrime WP75xx Embedded Module/AirPrime WP8548 Embedded Module:

- In areas where blasting is in progress
- Where explosive atmospheres may be present including refueling points, fuel depots, and chemical plants
- Near medical equipment, life support equipment, or any equipment which may be susceptible to any form of radio interference.

In such areas, the AirPrime WP75xx/AirPrime WP8548 modem **MUST BE POWERED OFF**. Otherwise, the AirPrime WP75xx/AirPrime WP8548 modem can transmit signals that could interfere with this equipment.

In an aircraft, the AirPrime WP75xx/AirPrime WP8548 modem **MUST BE POWERED OFF**. Otherwise, the AirPrime WP75xx/AirPrime WP8548 modem can transmit signals that could interfere with various onboard systems and may be dangerous to the operation

of the aircraft or disrupt the cellular network. Use of a cellular phone in an aircraft is illegal in some jurisdictions. Failure to observe this instruction may lead to suspension or denial of cellular telephone services to the offender, or legal action or both.

Some airlines may permit the use of cellular phones while the aircraft is on the ground and the door is open. The AirPrime WP75xx/AirPrime WP8548 modem may be used normally at this time.

9.5 Compliance Acceptance and Certification

The AirPrime WP75xx is designed to be compliant with the 3GPP Release 8 UTRA and Release 9 E-UTRA Specifications for Mobile Terminated Equipment. The AirPrime WP8548 is designed to be compliant with the 3GPP Release 8 UTRA Specification for Mobile Terminated Equipment.

Final regulatory and operator certification requires regulatory agency testing and approval with the fully integrated UE host device incorporating the AirPrime WP75xx/AirPrime WP8548 module.

The OEM host device and, in particular, the OEM antenna design and implementation will affect the final product functionality, RF performance, and certification test results.

Note: Tests that require features not supported by the AirPrime WP75xx/AirPrime WP8548 (as defined by this document) are not supported.

9.6 Regulatory Compliance

9.6.1 Important Compliance Information for North American Users

The AirPrime WP7504/AirPrime WP8548 module, upon commercial release, will have been granted modular approval for mobile applications. Integrators may use the AirPrime WP7504/AirPrime WP8548 module in their final products without additional FCC/IC (Industry Canada) certification if they meet the following conditions. Otherwise, additional FCC/IC approvals must be obtained.

1. The end product must use the RF trace design approved with the AirPrime WP7504/AirPrime WP8548 module. The Gerber file of the trace design can be obtained from Sierra Wireless upon request.
2. At least 20 cm separation distance between the antenna and the user's body must be maintained at all times.
3. To comply with FCC/IC regulations limiting both maximum RF output power and human exposure to RF radiation, the maximum antenna gain including cable loss in a

mobile-only exposure condition must not exceed the limits stipulated in [Table 9-1 on page 115](#).

Table 9-1: WP7504 Antenna Gain Specifications

Device	Technology	Band	Frequency (MHz)	Maximum antenna gain (dBi)
AirPrime WP7504	LTE	2	1850–1910	6
		4	1710–1755	6
		5	824–849	6
		12	699–716	6
		25	1850–1910	6
		26	814–849	6
	UMTS	2	1850–1910	6
		4	1710–1755	6
		5	824–849	6
	CDMA	BC0	824–849	6
BC1		1850–1910	6	
BC10		816–824	6	
AirPrime WP8548	UMTS	2	1850–1910	3
		5	824–849	4
	GPRS/EDGE	850	824–849	4
		1900	1850–1910	3

4. The AirPrime WP7504/AirPrime WP8548 module may transmit simultaneously with other collocated radio transmitters within a host device, provided the following conditions are met:
 - Each collocated radio transmitter has been certified by FCC/IC for mobile application.
 - At least 20 cm separation distance between the antennas of the collocated transmitters and the user's body must be maintained at all times.

- The output power of a collocated transmitter must not exceed the EIRP limit stipulated in [Table 9-2 on page 116](#).

Table 9-2: Collocated Radio Transmitter Specifications

Device	Technology	Frequency (MHz)	EIRP Limit (dBm)	
			AirPrime WP7504	AirPrime WP8548
Collocated transmitters ^a	WLAN	2400–2500	25	27
		5150–5850	27	27
	WiMAX	2300–2400	25	27
		2500–2700	25	27
		3300–3800	25	27
	BT	2400–2500	15	20

a. Valid collocated transmitter combinations: WLAN+BT; WiMAX+BT. (WLAN+WiMAX+BT is not permitted.)

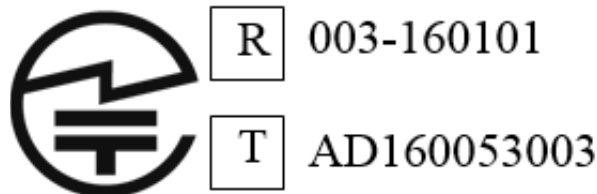
5. A label must be affixed to the outside of the end product into which the AirPrime WP7504/AirPrime WP8548 module is incorporated, with a statement similar to the following:
 - **(WP7504)— This device contains FCC ID: N7NWP7/IC:2417C-WP7.**
 - **(WP8548)— This device contains FCC ID: N7NWP8/IC:2417C-WP8.**
6. A user manual with the end product must clearly indicate the operating requirements and conditions that must be observed to ensure compliance with current FCC/IC RF exposure guidelines.

The end product with an embedded AirPrime WP7504/AirPrime WP8548 module may also need to pass the FCC Part 15 unintentional emission testing requirements and be properly authorized per FCC Part 15.

Note: If this module is intended for use in a portable device, you are responsible for separate approval to satisfy the SAR requirements of FCC Part 2.1093 and IC RSS-102.

9.6.2 Japan Regulatory Compliance

The AirPrime WP8548 module has been granted regulatory approval in Japan with the following certification numbers:



>> 10: Pinout

The system interface of the AirPrime WP75xx/AirPrime WP8548 is through the LGA pattern on the bottom of the PCB.

AirPrime WP75xx/AirPrime WP8548 pins are divided into three functional categories:

- Core functions and associated pins—Cover all the mandatory features for M2M connectivity and will be available by default across all CF3 family of modules. These Core functions are always available and always at the same physical pin locations. A customer platform using only these functions and associated pins is guaranteed to be forward and/or backward compatible with the next generation of CF3 modules.
- Extension functions and associated pins—Bring additional capabilities to the customer. Whenever an Extension function is available on a module, it is always at the same pin location.
- Custom functions and associated pins—These are module-specific and make use of specific chipset functions and I/Os.

Warning: *Custom features should be used with caution as there is no guarantee that the custom functions available on a given module will be available on other CF3 modules.*

Pins marked as "Leave open" or "Reserved" should not be used or connected.

10.1 Pin Configuration

Figure 10-1 illustrates the pin configuration of the AirPrime WP75xx/AirPrime WP8548 module.

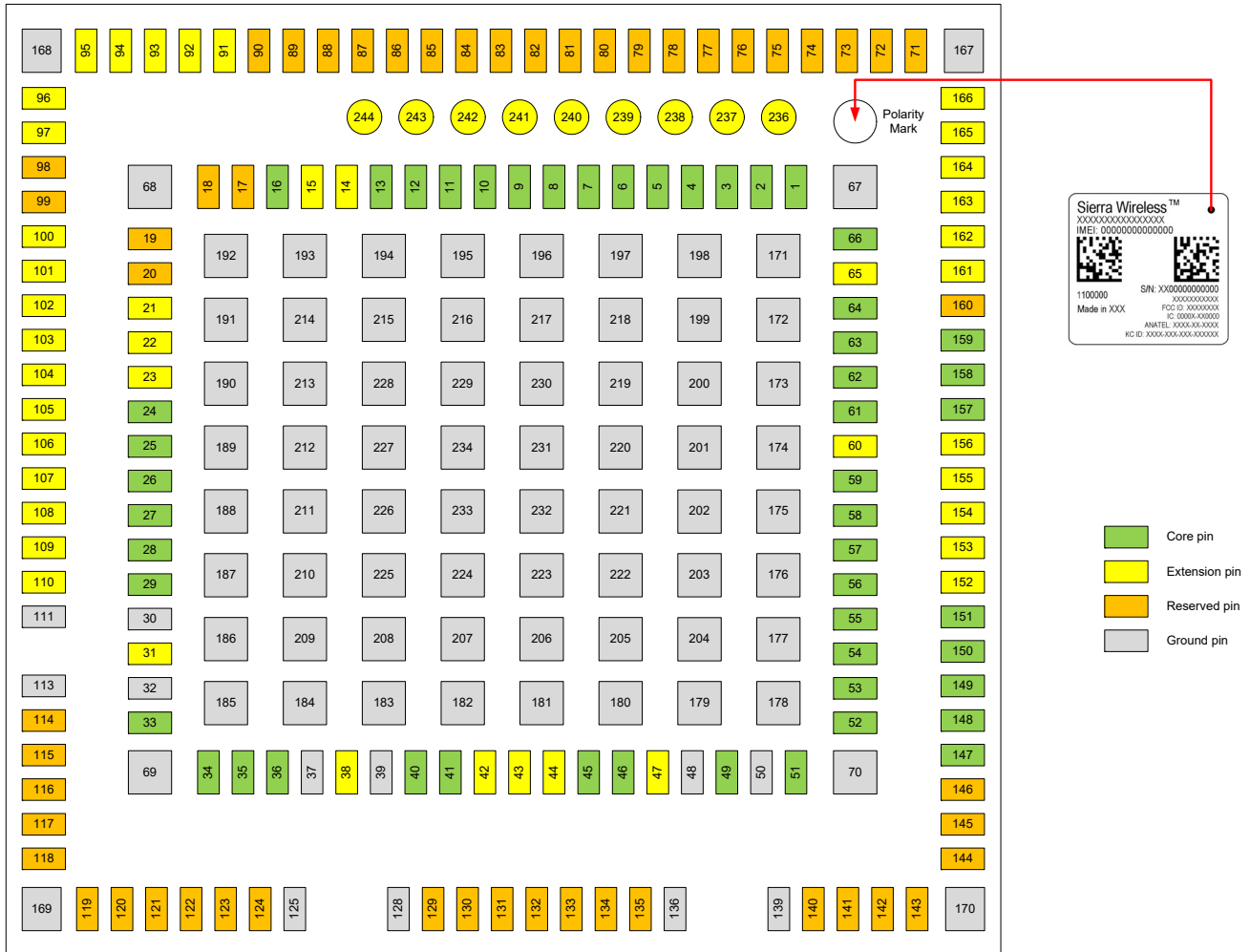


Figure 10-1: Pin Configuration (Top View)

10.2 Pin Description

Table 10-1 on page 119 lists detailed information for the LGA pins.

Note: Some pin numbers (112, 126, 127, 137, 138, 235) do not appear in this table because there are no corresponding pads on the module's PCB.

Table 10-1: Pin Definitions

Pin	Signal name	Group	I/O ^a	Voltage	PU/ PD ^b	Active	If unused	Function	Type
1	I2C1_CLK	I2C	I/O	1.8V	PU		Leave open	I ² C clock	Core
2	UART1_RI ^c	UART1	O	1.8V		H	Leave open	UART1 Ring indicator	Core
3	UART1_RTS ^c	UART1	I	1.8V		L	Leave open	UART1 Request to send	Core
4	UART1_CTS ^c	UART1	O	1.8V		L	Leave open	UART1 Clear to send	Core
5	UART1_TX ^c	UART1	I	1.8V			Leave open	UART1 Transmit data	Core
6	UART1_RX ^c	UART1	O	1.8V			Leave open	UART1 Receive data	Core
7	UART1_DTR ^c	UART1	I	1.8V		L	Leave open	UART1 Data terminal ready	Core
8	UART1_DCD ^c	UART1	O	1.8V		L	Leave open	UART1 Data carrier detect	Core
9	UART1_DSR ^c	UART1	O	1.8V		L	Leave open	UART1 Data set ready	Core
10	GPIO2 ^d	GPIO	I/O	1.8V	NP		Leave open	General purpose I/O	Core
11	RESET_IN_N	Control signal	I	1.8V	PU	L	Leave open	Input reset signal	Core
12	USB_D-	USB	I/O				Leave open	USB Data negative	Core
13	USB_D+	USB	I/O				Leave open	USB Data positive	Core
14	HSIC_DATA	HSIC	I/O				Leave open	High Speed Inter-Chip Data	Extension
15	HSIC_STRB	HSIC	I/O				Leave open	High Speed Inter-Chip Strobe	Extension
16	USB_VBUS ^e	USB	I	5V			Mandatory connection (Connect to USB_VBUS, or if unavailable, connect to VBAT_BB)	USB power supply	Core
17–20	Reserved	No Connection					See footnote ^f .		Extension
21	BAT_RTC	Power	I/O				Leave open	Power supply for RTC backup	Extension
22	SYS_CLK	Clock	O				Leave open	19.2 MHz digital clock output	Extension
23	SLEEP_CLK	Clock	O				Leave open	32.768 kHz digital clock output	Extension
24	ADC1	ADC	I				Leave open	Analog to digital conversion	Core
25	ADC0	ADC	I				Leave open	Analog to digital conversion	Core
26	UIM1_VCC	UIM1	O	1.8V/3V			Mandatory connection	1.8V/3V UIM1 Power supply	Core

Table 10-1: Pin Definitions (Continued)

Pin	Signal name	Group	I/O ^a	Voltage	PU/ PD ^b	Active	If unused	Function	Type
27	UIM1_CLK	UIM1	O	1.8V/3V			Mandatory connection	UIM1 Clock	Core
28	UIM1_DATA	UIM1	I/O	1.8V/3V			Mandatory connection	UIM1 Data	Core
29	UIM1_RESET_N	UIM1	O	1.8V/3V		L	Mandatory connection	UIM1 Reset	Core
30	GND	Ground	0V	0V			Mandatory connection	(WP75xx) Diversity antenna ground	Extension
								(WP8548) Ground	
31	(WP75xx) RF_DIV	RF						See footnote ^f .	Extension
	(WP8548) Reserved								
32	GND	Ground	0V	0V			Mandatory connection	(WP75xx) Diversity antenna ground	Extension
								(WP8548) Ground	
33	PCM_OUT	PCM	O	1.8V			Leave open	PCM data out	Core
	I2S_OUT	I2S	O	1.8V			Leave open	I2S data out	
34	PCM_IN	PCM	I	1.8V			Leave open	PCM data in	Core
	I2S_IN	I2S	I	1.8V			Leave open	I2S data in	
35	PCM_SYNC	PCM	Pri: I/O Aux: O	1.8V			Leave open	PCM sync	Core
	I2S_WS	I2S	O	1.8V			Leave open	I2S word select	
36	PCM_CLK	PCM	Pri: I/O Aux: O	1.8V			Leave open	PCM clock	Core
	I2S_CLK	I2S	O	1.8V			Leave open	I2S clock	
37	GND	RF	0V	0V			Mandatory connection	GNSS antenna ground	Core
38	RF_GNSS ^g	RF					Mandatory connection	RF GNSS input	Extension
39	GND	RF	0V	0V			Mandatory connection	GNSS antenna ground	Core
40	GPIO7 ^d	GPIO	I/O	1.8V	NP		Leave open	General purpose I/O	Core
41	GPIO8	GPIO	I/O	1.8V	NP		Leave open	General purpose I/O	Core
42	DR_SYNC ^g	GPS	O	1.8V			Leave open	GPS dead reckoning sync	Extension
43	Reserved	No Connection							Extension
44	GPIO13 ^d	GPIO	I/O	1.8V	NP		Leave open	General purpose I/O	Extension
45	VGPIO	Voltage reference	O	1.8V			Leave open	GPIO voltage output	Core

Table 10-1: Pin Definitions (Continued)

Pin	Signal name	Group	I/O ^a	Voltage	PU/ PD ^b	Active	If unused	Function	Type
46	RESET_OUT_N	Control signal	O	1.8V	PD	L	Leave open	Reset	Core
	GPIO6	GPIO	I/O	1.8V	NP		Leave open	General purpose I/O	Extension
47	TP1 (Boot pin)	Boot	I	1.8V		L	Mandatory test point	Test point 1 <ul style="list-style-type: none"> 0—Download mode Open—Normal mode 	Extension
48	GND	RF	0V	0V			Mandatory connection	Main antenna ground	Core
49	RF_MAIN	RF					Mandatory connection	Main RF antenna	Core
50	GND	RF	0V	0V			Mandatory connection	Main antenna ground	Core
51	SPI1_MRDY	SPI1	O	1.8V			Leave open	SPI Master Ready	Core
52	SPI1_MISO	SPI1	I	1.8V			Leave open	SPI Master Input/Slave Output (output from slave)	Core
53	SPI1_CLK	SPI1	O	1.8V			Leave open	SPI serial clock (output from Master)	Core
54	SPI1_MOSI	SPI1	O	1.8V			Leave open	SPI Master Output/ Slave Input (output from master)	Core
55	UIM2_VCC	UIM2	O	1.8V/3V			Optional connection	UIM2 Power supply	Core
56	UIM2_DATA	UIM2	I/O	1.8V/3V			Optional connection	UIM2 Data	Core
57	UIM2_RESET_N	UIM2	O	1.8V/3V		L	Optional connection	UIM2 Reset	Core
58	UIM2_CLK	UIM2	O	1.8V/3V			Optional connection	UIM2 Clock	Core
59	POWER_ON_N	Control	I	1.8V	PU	L	Mandatory connection	Power On control signal	Core
60	TX_ON	Indication	O	1.8V		H	Leave open	Tx activity indicator	Extension
61	VBAT_RF	Power	I	3.4V (min) 3.7V (typ) 4.3V (max)			Mandatory connection	RF power supply (see Power Supply Ratings on page 35)	Core
62	VBAT_RF	Power	I	3.4V (min) 3.7V (typ) 4.3V (max)			Mandatory connection	RF power supply (see Power Supply Ratings on page 35)	Core
63	VBAT_BB	Power	I	3.4V (min) 3.7V (typ) 4.3V (max)			Mandatory connection	Baseband power supply (see Power Supply Ratings on page 35)	Core

Table 10-1: Pin Definitions (Continued)

Pin	Signal name	Group	I/O ^a	Voltage	PU/ PD ^b	Active	If unused	Function	Type
64	UIM1_DET	UIM1		1.8V			Mandatory connection	Detect UIM1 insertion/removal. (Pin must be open to detect the UIM, or grounded if no UIM is present.)	Core
65	UIM2_DET	UIM2		1.8V			Ground	Detect UIM2 insertion/removal (Pin must be open to detect the UIM, or grounded if no UIM is present.)	Extension
66	I2C1_Data	I2C	I/O	1.8V	PU		Leave open	I ² C data	Core
67–70	GND	Ground	0V	0V			Mandatory connection	Ground	Core
71–90	Reserved	No Connection					See footnote ^f .		
91	USB_ID	USB	I				Leave open	Reserved for use with USB OTG	Extension
92	GPIO38 ^{h,i}	GPIO	I/O	1.8V	NP		Leave open	General purpose I/O	Extension
93	GPIO39 ^{h,i}	GPIO	I/O	1.8V	NP		Leave open	General purpose I/O	Extension
94	GPIO40 ^{h,j}	GPIO	I/O	1.8V	NP		Leave open	General purpose I/O	Extension
95	GPIO41 ^{h,j}	GPIO	I/O	1.8V	NP		Leave open	General purpose I/O	Extension
96	UART2_TX ^c	UART2	I	1.8V			Leave open	UART2 Transmit data	Extension
97	UART2_RX ^c	UART2	O	1.8V			Leave open	UART2 Receive data	Extension
98	Reserved	No Connection							
99	Reserved	No Connection							
100	GPIO34 ^h	GPIO	I/O	1.8V	NP		Leave open	General purpose I/O	Extension
101	GPIO35 ^h	GPIO	I/O	1.8V	NP		Leave open	General purpose I/O	Extension
102	GPIO36 ^{h,i}	GPIO	I/O	1.8V	NP		Leave open	General purpose I/O	Extension
103	GPIO37 ^h	GPIO	I/O	1.8V	NP		Leave open	General purpose I/O	Extension
104	GPIO32 ^d	GPIO	I/O	1.8V	NP		Leave open	General purpose I/O	Extension
105	GPIO33 ^d	GPIO	I/O	1.8V	NP		Leave open	General purpose I/O	Extension
106	WWAN_LED_N	Indication	O	VBAT_BB ^k		L	Leave open		Extension
107	ADC2	ADC	I				Leave open		Extension
108	ADC3	ADC	I				Leave open		Extension
109	GPIO42 ^d	GPIO	I/O	1.8V	NP		Leave open	General purpose I/O	Extension
110	WAKE_ON_WWAN	Indication	O	1.8V		H	Leave open	Driven high to wake the host when specific events occur.	Extension

Table 10-1: Pin Definitions (Continued)

Pin	Signal name	Group	I/O ^a	Voltage	PU/ PD ^b	Active	If unused	Function	Type
111	GND	Ground	0V	0V			Mandatory connection	(WP75xx) Diversity antenna ground	Core
								(WP8548) Ground	
113	GND	Ground	0V	0V			Mandatory connection	(WP75xx) Diversity antenna ground	Core
								(WP8548) Ground	
114–124	Reserved	No Connection					See footnote ^f .		
125	GND	RF	0V	0V			Mandatory connection	GNSS antenna ground	Core
128	GND	RF	0V	0V			Mandatory connection	GNSS antenna ground	Core
129–135	Reserved	No Connection					See footnote ^f .		
136	GND	RF	0V	0V			Mandatory connection	Main antenna ground	Core
139	GND	RF	0V	0V			Mandatory connection	Main antenna ground	Core
140–146	Reserved	No Connection					See footnote ^f .		
147	GPIO21 ^d	GPIO	I/O	1.8V	NP		Leave open	General purpose I/O	Core
148	GPIO22	GPIO	I/O	1.8V	NP		Leave open	General purpose I/O	Core
149	GPIO23	GPIO	I/O	1.8V	NP		Leave open	General purpose I/O	Core
150	GPIO24	GPIO	I/O	1.8V	NP		Leave open	General purpose I/O	Core
151	W_DISABLE_N	Control	I	1.8V		L		Wireless disable (main RF radio)	Core
152	SAFE_PWR_REMOVE	Indication	O	1.8V		H	Leave open	Indicate to host that Main DC power can be removed	Extension
153	ANT_CNTL0	Antenna control	O	1.8V			Leave open		Extension
	GPIO28 ^l	GPIO	I/O	1.8V	NP		Leave open	General purpose I/O	Extension
154	ANT_CNTL1	Antenna control	O	1.8V			Leave open		Extension
	GPIO29 ^l	GPIO	I/O	1.8V	NP		Leave open	General purpose I/O	Extension
155	ANT_CNTL2	Antenna control	O	1.8V			Leave open		Extension
	GPIO30 ^l	GPIO	I/O	1.8V	NP		Leave open	General purpose I/O	Extension
156	ANT_CNTL3	Antenna control	O	1.8V			Leave open		Extension
	GPIO31 ^l	GPIO	I/O	1.8V	NP		Leave open	General purpose I/O	Extension
157	VBAT_RF	Power	I	3.4V (min) 3.7V (typ) 4.3V (max)			Optional connection	RF power supply (see Power Supply Ratings on page 35)	Core

Table 10-1: Pin Definitions (Continued)

Pin	Signal name	Group	I/O ^a	Voltage	PU/ PD ^b	Active	If unused	Function	Type
158	VBAT_BB	Power	I	3.4V (min) 3.7V (typ) 4.3V (max)			Optional connection	Baseband power supply (see Power Supply Ratings on page 35)	Core
159	GPIO25	GPIO	I/O	1.8V	NP		Leave open	General purpose I/O	Core
160	Reserved	No Connection					See footnote ^f .		
161	SDIO_CMD	SDIO	O	2.95V			Leave open	SDIO command	Extension
162	SDIO_CLK	SDIO	O	2.95V			Leave open	SDIO clock	Extension
163	SDIO_DATA_3	SDIO	I/O	2.95V			Leave open	SDIO data bit 3	Extension
164	SDIO_DATA_2	SDIO	I/O	2.95V			Leave open	SDIO data bit 2	Extension
165	SDIO_DATA_1	SDIO	I/O	2.95V			Leave open	SDIO data bit 1	Extension
166	SDIO_DATA_0	SDIO	I/O	2.95V			Leave open	SDIO data bit 0	Extension
167–234	GND	Ground	0V	0V			Mandatory connection	Ground	Core
236	J1 ^m			1.8V		L	Mandatory test point	Test point	Extension
237	J2 ^m			1.8V			Mandatory test point	Test point	Extension
238	J3 ^m			1.8V			Mandatory test point	Test point	Extension
239	J4 ^m			1.8V			Mandatory test point	Test point	Extension
240	J5 ^m			1.8V		L	Mandatory test point	Test point	Extension
241	J6 ^m			1.8V			Mandatory test point	Test point	Extension
242	J7 ^m			1.8V			Mandatory test point	Test point	Extension
243	J8 ^m			1.8V			Mandatory test point	Test point	Extension
244	J9 ^m			1.8V			Mandatory test point	Test point	Extension

- a. Signal direction with respect to the module. Examples: PCM_OUT (pin 33) is an output from the module to the host; PCM_IN (pin 34) is an input to the module from the host.
- b. NP—No Pull; PD—Pull Down; PU—Pull Up
- c. (UART signals only) Signals are named with respect to the host device. For example, UART1_RX is the signal used by the host to receive data from the module.
- d. Wakeable GPIO. See [WakeUp Interrupt \(USB-SS Mode\) on page 76](#) for details.
- e. Not currently connected internally, but customer solutions should provide this input for compatibility with future module revisions.
- f. Pins are not connected internally, but are reserved for future use. Leave them unconnected to ensure compatibility with other Sierra Wireless CF3 modules.
- g. (WP75xx) Support is SKU-dependent; (WP8548) Supported.
- h. Accessible via sysfs/Legato only.
- i. Can be configured as a wakeup trigger for ULPM. See [Power Consumption States on page 38](#) for details.
- j. GPIO40 and GPIO41 may be unavailable in future WP products.
- k. Maximum rating is VBAT_BB + 0.5V, with maximum current sink capability of 300 mA.
- l. GPIOs 28–31 are available for use when configured using AT+WIOCFG.
- m. Accessibility restricted to soldered-down modules. Not available for socket-mounted modules.

Table 10-2: RF Pin Information

Signal name	Pin #	Description
(WP75xx) RF_DIV	31	Diversity input
RF_GNSS ^a	38	RF GNSS input
RF_MAIN	49	Main RF port (input/output)

a. WP75xx—Support is SKU-dependent; WP8548—Supported

Table 10-3: Supply Pin Information

Signal name	Pin #	Description
VBAT_RF	61, 62, 157	RF power supply
VBAT_BB	63, 158	Baseband power supply
BAT_RTC	21	Power supply for RTC backup
USB_VBUS	16	Connected to VBAT_BB

Table 10-4: Ground & Reserved Pin Information

Signal name	Pin #	Description
Ground	30, 32, 37, 39, 48, 50, 67–70, 111, 113, 125, 128, 136, 139, 167–234	Ground connection
Reserved	17–20, (WP8548) 31, 71–90, 114–124, 129–135, 140–146, 160	Pins are not connected internally, but are reserved for future use. Leave them unconnected to ensure compatibility with other Sierra Wireless CF3 modules.

>> 11: Customization

Subject to commercial terms, Sierra Wireless can supply custom-configured modems to facilitate a carrier's network and performance requirements. Sierra Wireless also offers a standard configuration for each country.

Custom configurations are entered into a selector spreadsheet that Sierra supplies. A unique part number is assigned to each custom configuration to facilitate customer ordering.

Table 11-1: Customizable Features

Name	Description	Default
Display of IMSI	Display of International Mobile Subscriber Identity via AT+CIMI command	Display enabled
UART baud rate	Default UART speed	115200 bps
UART enabled	Defines whether UART port is enabled by default or not	UART disabled

>> 12: References

For more details, several references can be consulted, as detailed below.

12.1 Web Site Support

Check <http://source.sierrawireless.com> for the latest documentation available for the AirPrime WP75xx/AirPrime WP8548.

12.2 Reference Documents

- [1] AirPrime WPx5/WP76xx/WP77xx AT Command Reference
Reference number: 4118047
- [2] Inter-Chip USB Supplement to the USB 2.0 Specification Revision 1.0
- [3] Legato.io for Legato API details
- [4] AirPrime WPx5 Series Customer Process Guidelines
- [5] The I²C Bus Specification, Version 2.1, January 2000 (Phillips Semiconductor document number 9398 393 40011)

>> 13: Abbreviations

Table 13-1: Acronyms and Definitions

Acronym or term	Definition
3GPP	3rd Generation Partnership Project
8PSK	Octagonal Phase Shift Keying
ADC	Analog to Digital Converter
AF	Audio-Frequency
API	Application Programming Interface
AT	Attention (prefix for modem commands)
BeiDou	BeiDou Navigation Satellite System A Chinese system that uses a series of satellites in geostationary and middle earth orbits to provide navigational data.
BER	Bit Error Rate—A measure of receive sensitivity
BLER	Block Error Rate
Bluetooth	Wireless protocol for data exchange over short distances
CEP	Circular Error Probable
CF3	Common Flexible Form Factor
CLK	Clock
CMOS	Complementary Metal Oxide Semiconductor
CPU	Central Processing Unit
CQI	Channel Quality Indication
CS	Circuit-Switched
	Coding Scheme
CTS	Clear To Send
CW	Continuous waveform
DAC	Digital to Analog Converter
dB	Decibel = $10 \times \log_{10} (P1/P2)$ <i>P1 is calculated power; P2 is reference power</i> Decibel = $20 \times \log_{10} (V1/V2)$ <i>V1 is calculated voltage, V2 is reference voltage</i>
dBm	A logarithmic (base 10) measure of relative power (dB for decibels); relative to milliwatts (m). A dBm value will be 30 units (1000 times) larger (less negative) than a dBW value, because of the difference in scale (milliwatts vs. watts).
DC	Direct Current
DCD	Data Carrier Detect

Table 13-1: Acronyms and Definitions (Continued)

Acronym or term	Definition
DCS	Digital Cellular System A cellular communication infrastructure that uses the 1.8 GHz radio spectrum.
DL	Downlink (network to mobile)
DRX	Discontinuous Reception
DSR	Data Set Ready
DTR	Data Terminal Ready
E-GSM	Extended GSM
EDGE	Enhance Data rates for GSM Evolution
EFR	Enhanced Full Rate
EFS	Embedded File System
EGPRS	Enhance GPRS
EIRP	Effective (or Equivalent) Isotropic Radiated Power
EMC	Electromagnetic Compatibility
EN	Enable
ERP	Effective Radiated Power
ESD	Electrostatic Discharges
ETSI	European Telecommunications Standards Institute
FCC	Federal Communications Commission The U.S. federal agency that is responsible for interstate and foreign communications. The FCC regulates commercial and private radio spectrum management, sets rates for communications services, determines standards for equipment, and controls broadcast licensing. Consult www.fcc.gov .
FDD	Frequency Division Duplexing
FDMA	Frequency Division Multiple Access
firmware	Software stored in ROM or EEPROM; essential programs that remain even when the system is turned off. Firmware is easier to change than hardware but more permanent than software stored on disk.
FOV	Field Of View
FR	Full Rate
FSN	Factory Serial Number—A unique serial number assigned to the mini card during manufacturing.
Galileo	A European system that uses a series of satellites in middle earth orbit to provide navigational data.
GCF	Global Certification Forum
GLONASS	Global Navigation Satellite System—A Russian system that uses a series of 24 satellites in middle circular orbit to provide navigational data.

Table 13-1: Acronyms and Definitions (Continued)

Acronym or term	Definition
GMSK	Gaussian Minimum Shift Keying modulation
GND	Ground
GNSS	Global Navigation Satellite Systems (GPS, GLONASS, BeiDou, and Galileo)
GPIO	General Purpose Input Output
GPRS	General Packet Radio Service
GPS	Global Positioning System An American system that uses a series of 24 satellites in middle circular orbit to provide navigational data.
GSM	Global System for Mobile communications
Hi Z	High impedance (Z)
Host	The device into which an embedded module is integrated
HR	Half Rate
HSDPA	High Speed Downlink Packet Access
HSUPA	High Speed Uplink Packet Access
Hz	Hertz = 1 cycle/second
I/O	Input/Output
IC IC	Industry Canada Integrated Circuit
IMEI	International Mobile Equipment Identity
IMS	IP Multimedia Subsystem—Architectural framework for delivering IP multimedia services.
inrush current	Peak current drawn when a device is connected or powered on
IOT	Interoperability Testing
IS	Interim Standard. After receiving industry consensus, the TIA forwards the standard to ANSI for approval.
ISIM	IMS Subscriber Identity Module.
LED	Light Emitting Diode. A semiconductor diode that emits visible or infrared light.
LGA	Land Grid Array
LHCP	Left-Hand Circular Polarized
LNA	Low noise Amplifier
LTE	Long Term Evolution—a high-performance air interface for cellular mobile communication systems.
MAX	Maximum

Table 13-1: Acronyms and Definitions (Continued)

Acronym or term	Definition
MCS	Modulation and Coding Scheme
MHz	Megahertz = 10e6 Hz
MIC	Microphone
MIMO	Multiple Input Multiple Output—wireless antenna technology that uses multiple antennas at both transmitter and receiver side. This improves performance.
MIN	Minimum
MO	Mobile Originated
MT	Mobile Terminated
N/A	Not Applicable
NMEA	National Marine Electronics Association
NOM	Nominal
OEM	Original Equipment Manufacturer—a company that manufactures a product and sells it to a reseller.
PA	Power Amplifier
packet	A short, fixed-length block of data, including a header, that is transmitted as a unit in a communications network.
PBCCH	Packet Broadcast Control Channel
PC	Personal Computer
PCB	Printed Circuit Board
PCL	Power Control Level
PCS	Personal Communication System A cellular communication infrastructure that uses the 1.9 GHz radio spectrum.
PDN	Packet Data Network
PFM	Power Frequency Modulation
PLL	Phase Lock Loop
PMIC	Power Management Integrated Circuit
PSM	Phase Shift Modulation
PSS	Primary synchronisation signal
PST	Product Support Tools
PTCRB	PCS Type Certification Review Board
PWM	Pulse Width Modulation

Table 13-1: Acronyms and Definitions (Continued)

Acronym or term	Definition
QAM	Quadrature Amplitude Modulation. This form of modulation uses amplitude, frequency, and phase to transfer data on the carrier wave.
QPSK	Quadrature Phase-Shift Keying
RAM	Random Access Memory
RAT	Radio Access Technology
RF	Radio Frequency
RHCP	Right Hand Circular Polarization
RI	Ring Indicator
RSE	Radiated Spurious Emissions
RSSI	Received Signal Strength Indication
RST	Reset
RTC	Real Time Clock
RTS	Request To Send
RX	Receive
SCLK	Serial Clock
SED	Smart Error Detection
Sensitivity (Audio)	Measure of lowest power signal that the receiver can measure.
Sensitivity (RF)	Measure of lowest power signal at the receiver input that can provide a prescribed BER/BLER/ SNR value at the receiver output.
SIM	Subscriber Identity Module.
SKU	Stock Keeping Unit—identifies an inventory item: a unique code, consisting of numbers or letters and numbers, assigned to a product by a retailer for purposes of identification and inventory control.
SMS	Short Message Service
SNR	Signal-to-Noise Ratio
SPI	Serial Peripheral Interface
SPK	Speaker
SW	Software
TBC	To Be Confirmed
TBD	To Be Determined
TIA/EIA	Telecommunications Industry Association / Electronics Industry Association. A standards setting trade organization, whose members provide communications and information technology products, systems, distribution services and professional services in the United States and around the world. Consult www.tiaonline.org .

Table 13-1: Acronyms and Definitions (Continued)

Acronym or term	Definition
TIS	Total Isotropic Sensitivity
TP	Test Point
TRP	Total Radiated Power
TX	Transmit
TYP	Typical
UART	Universal Asynchronous Receiver-Transmitter
UE	User Equipment
UICC	Universal Integrated Circuit Card
UIM	User Identity Module. Generic term used in this document to refer to UICC, where the application on the UICC (USIM, ISIM, CSIM, etc.) varies depending on the provider of the card.
UL	Uplink (mobile to network)
UMTS	Universal Mobile Telecommunications System
USB	Universal Serial Bus
USB-SS	USB Selective Suspend/USB not enumerated
USIM	Universal Subscriber Identity Module (UMTS)
USSD	Unstructured Supplementary Services Data
UTRA	UMTS Terrestrial Radio Access
VBAT-BB	Baseband power supply
VBAT-RF	RF power supply
VCC	Supply voltage
VSWR	Voltage Standing Wave Ratio
WCDMA	Wideband Code Division Multiple Access (also referred to as UMTS)
WLAN	Wireless Local Area Network
WWAN	Wireless Wide Area Network
ZIF	Zero Intermediate Frequency

>> 14: Testing

14.1 Certification Testing

Note: Typically, certification testing of your device with the integrated module is required one time only.

The AirPrime WP75xx Embedded Module/AirPrime WP8548 Embedded Module has been certified as described in [Regulatory Compliance and Industry Certifications on page 95](#).

When you produce a host device with a Sierra Wireless AirPrime embedded module, you must obtain certifications for the final product from appropriate regulatory bodies in the jurisdictions where it will be distributed.

The following are *some* of the regulatory bodies from which you may require certification—it is your responsibility to make sure that you obtain all necessary certifications for your product from these or other groups:

- FCC (Federal Communications Commission—www.fcc.gov)
- Industry Canada (www.ic.gc.ca)
- GCF (Global Certification Forum—www.globalcertificationforum.org) outside of North America
- PTCRB (PCS Type Certification Review Board—www.ptcrb.com) in North America

14.2 Production Testing

Note: Production testing typically continues for the life of the product.

Production testing ensures that, for each assembled device, the module is installed correctly (I/O signals are passed between the host and module), and the antenna is connected and performing to specifications (RF tests).

Typical items to test include:

- Host connectivity
- Baseband (host/module connectors)
- RF assembly (Tx and/or Rx, as appropriate)
- Network availability
- Host/device configuration issues

*Note: The number and types of tests to perform are **your** decision—the tests listed in this section are guidelines only. Make sure that the tests you perform exercise functionality to the degree that **your** situation requires.*

Use an appropriate test station and use AT commands to control the integrated module.

Note: Your test location must be protected from ESD to avoid interference with the module and antenna(s), assuming that your test computer is in a disassembled state.

Also, consider using an RF shielding box—local government regulations may prohibit unauthorized transmissions.

Note: The tests described in this chapter are done using a Linux O/S (e.g. Ubuntu 12.04).

14.3 Functional Production Test

This section presents a suggested procedure for performing a basic manual functional test on a laboratory bench using an AirPrime WP75xx Embedded Module/AirPrime WP8548 Embedded Module and a hardware development kit. When you have become familiar with the testing method, use it to develop your own automated production testing procedures.

14.3.1 Suggested Production Tests

Consider the following tests when you design your production test procedures for devices with the AirPrime module installed.

- Visual check of the module's connectors and RF assemblies
- Module is operational
- USB connection is functional
- LED is functional
- Power on/off
- Firmware revision check
- Rx tests on main and auxiliary paths
- Tx test

14.3.2 Production Test Procedure

The following is a suggested test plan—you must decide which tests are appropriate for your product. You may wish to add additional tests that more fully exercise the capabilities of your product.

Using an appropriate test station, and referring to the appropriate AT command references:

1. Visually inspect the module for obvious defects (such as tainted or damaged shields) before installing it in the test station.
2. Ensure that the module is powered off (no voltage on VBAT_BB/VBAT_RF) before beginning your tests.
3. Determine whether any USB devices are currently connected to the computer:
 - a. Open a shell window and enter the command `ls /dev/tty/USB*`.
 - b. Record the `ttyUSBn` values that are returned; these are the currently connected USB devices. If the command returns “no such file or directory”, there are no devices currently connected.
4. Provide power to the module (voltage on VBAT_BB/VBAT_RF).

5. Test POWER_ON_N—Turn on the module by driving POWER_ON_N low, as shown in [Figure 4-1 on page 70](#).
6. Test USB functionality—Check for USB enumeration.
Enter the command `ls /dev/tty/USB*` and then record and compare the results with those from [Step 3](#). If there are any new `ttyUSBn` devices, then the modem has enumerated successfully. (The AT port is usually the *last* new device.)
7. Make sure your modem is connected and running, and then establish contact with the module:
Use a terminal emulation/communications program such as `minicom` to connect over the device handle for AT commands (see listings in [Step 6](#)):

Note: If the command “minicom” is not found, then use a different program, or download minicom and repeat this step. See [Downloading and Configuring minicom for Linux Systems on page 137](#) for details.

- i. Start `minicom`:
 - First use of the modem: From the command line, type `minicom -s`. (The ‘-s’ switch shows the configuration menu.)
 - Subsequent uses: From the command line, type `minicom`. (The ‘-s’ switch is assumed.)

The `minicom` configuration details appear and the message OK appears when the connection is established.

```

CA Telnet 00.0.00.00
Welcome to minicom 2.2
OPTIONS: I18n
Compiled on Apr 27 2007, 15:50:20.
Port /dev/ttyUSB2

          Press CTRL-A Z for help on special keys

AT S7=45 S0=0 L1 U1 X4 &c1 E1 Q0
OK
CTRL-A Z for help !115200 8N1 ! NOR ! Minicom 2.2 ! UT102 ! Offline

```

8. Display the firmware version:
 - `ATI`
9. Unlock the extended AT command set. (Note: Use `ATI!ENTERCND?` to check command syntax, which is SKU-dependent.):
 - `ATI!ENTERCND="<password>"`
10. Test the LED—Visually confirm that the LED turns on and off using:
 - `AT!LDTEST=0,1` (LED on)
 - `AT!LDTEST=0,0` (LED off)
11. Put the module in diagnostic/factory test mode:
 - `AT!DAFTMACT`
12. Communicate with the SIM using `AT+CPIN` or `AT+CIMI`.
13. Test RF transmission, if desired:
 - (UMTS) See [UMTS \(WCDMA\) RF Transmission Path Test on page 138](#).
 - (LTE) See [LTE RF Transmission Path Test \(WP75xx\) on page 140](#).

14. Test RF reception, if desired:
 - (UMTS) See [UMTS \(WCDMA\) RF Receive Path Test on page 142](#).
 - (LTE) See [LTE RF Receive Path Test \(WP75xx\) on page 145](#).
15. Test standalone GNSS functionality—See [GNSS RF Receive Path Test on page 147](#).
16. Remove power from the module.

14.3.2.1 Downloading and Configuring minicom for Linux Systems

Note: This procedure is for Ubuntu systems. If you are using a different Linux distribution, use the appropriate commands for your system to download minicom.

To download and configure minicom in a Ubuntu system:

Note: To install minicom, you must have root access, or be included in the sudoers list.

1. Download and install minicom—enter the following command:
`sudo apt-get install minicom`
2. When prompted, enter your user password to begin the download and installation. When minicom is installed, the shell prompt appears.
3. Configure minicom to communicate with your modem:
 - a. Start minicom with the following command:
`minicom -s`
4. Use the down-arrow key to select the **Serial port setup** option.
5. Refer to [Step 6](#) on page 136 to identify the device file handle (/dev/ttyUSBn) used for AT commands.
6. Indicate the file handle to use for AT commands—Enter A and then replace the serial device string with the AT file handle.
7. Press **Enter** twice.
8. Use the down-arrow key to select **Save setup as dfl**.
9. Select **Exit**.

14.4 UMTS (WCDMA) RF Transmission Path Test

Note: This procedure segment is performed in Step 13 of the Production Test Procedure on page 135.

The suggested test procedure that follows uses the parameters in the following tables.

Table 14-1: Test Settings—WP7502 UMTS Transmission Path

	Band	Band ID	Tx Channel ^a
2100 MHz	Band 1	9	9750
900 MHz	Band 8	29	2787

a. Channel values shown are at the center of the corresponding bands.

Table 14-2: Test Settings—WP7504 UMTS Transmission Path

	Band	Band ID	Tx Channel ^a
1900 MHz	Band 2	15 ^b	9400
1700 MHz	Band 4	28	1412
850 MHz	Band 5	22	4182

a. Channel values shown are at the center of the corresponding bands.

b. Either 15 (WCDMA1900A) or 16 (WCDMA1900B) may be used for testing.

Table 14-3: Test Settings—WP8548 UMTS Transmission Path

	Band	Band ID	Tx Channel ^a
2100 MHz	Band 1	9	9750
1900 MHz	Band 2	15 ^b	9400
850 MHz	Band 5	22	4182
900 MHz	Band 8	29	2787

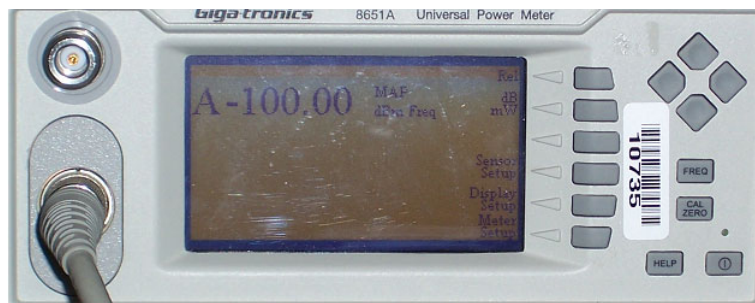
a. Channel values shown are at the center of the corresponding bands.

b. Either 15 (WCDMA1900A) or 16 (WCDMA1900B) may be used for testing.

To test the DUT's transmitter path:

Note: This procedure describes steps using the "Power Meter: Gigatronics 8651A" (with Option 12 and Power Sensor 80701A).

1. Set up the power meter:



- a. Make sure the meter has been given sufficient time to warm up, if necessary, to enable it to take accurate measurements.
 - b. Zero-calibrate the meter.
 - c. Enable MAP mode.
2. Prepare the DUT using the following AT commands:
 - a. `ATIINTERCND=<password>` (Unlock extended AT command set.)
 - b. `ATIDAFTMACT` (Enter test mode.)
 - c. `ATIDASBAND=<bandValue>` (Set frequency band.)
 - See [Table 14-1 on page 138](#), [Table 14-2 on page 138](#), or [Table 14-3 on page 138](#) for appropriate `<bandValue>` values
 - d. `ATIDASCHAN=<channel>` (Set modem channel)
 - See [Table 14-1 on page 138](#), [Table 14-2 on page 138](#), or [Table 14-3 on page 138](#) for appropriate `<channel>` values
 - e. `ATIDASTXON` (Turns on the transmit path.)
 - f. `ATIDAWSTXCW=0` (Use a modulated carrier.)
`ATIDASPDM=2, 75` (Set the power level. Repeat command with different offsets until desired Tx power is obtained.)
 - g. Set the PA gain state as appropriate:
 - For high gain state:
`ATIDAWSPARANGE=0`
 - or
 - For low gain state:
`ATIDAWSPARANGE=1`
 - h. Offset the tracking (If necessary, repeat with different offsets until the desired frequency is obtained.)
`ATIDASPDM=4,35100`
 - i. Take the measurement.
 - j. `ATIDASTXOFF` (Turn off the transmitter.)
 3. Test limits—Run ten or more good DUTs through this test procedure to obtain a nominal output power value.
 - Apply a tolerance of ± 5 to 6 dB to each measurement (assuming a good setup design).
 - Monitor these limits during mass-production ramp-up to determine if further adjustments are needed.

Note: The module has a nominal output power of +23 dBm \pm 1 dB in WCDMA mode. However, the value measured by the power meter is significantly influenced (beyond the stated \pm 1 dB output power tolerance) by the test setup (host RF cabling loss, antenna efficiency and pattern, test antenna efficiency and pattern, and choice of shield box).

Note: When doing the same test over the air in an RF chamber, values are likely to be significantly lower.

14.5 LTE RF Transmission Path Test (WP75xx)

Note: This procedure segment is performed in [Step 13](#) of the [Production Test Procedure on page 135](#).

The suggested test procedure that follows uses the parameters in the following tables.

Table 14-4: Test Settings—WP7502 LTE Transmission Path

	Band	Band ID	Tx Channel ^a
2100 MHz	Band 1	9	9750
1800 MHz	Band 3	44	19575
2600 MHz	Band 7	35	21100
900 MHz	Band 8	29	2787
800 MHz	Band 20	56	24300

a. Channel values shown are at the center of the corresponding bands.

Table 14-5: Test Settings—WP7504 LTE Transmission Path

	Band	Band ID	Tx Channel ^a
1900 MHz	Band 2	15 ^b	9400
1700 MHz	Band 4	28	1412
850 MHz	Band 5	22	4182
700 MHz	Band 12	50	23095
700 MHz	Band 17	37	23790
1900 MHz	Band 25	61	26365
850 MHz	Band 26	62	26865

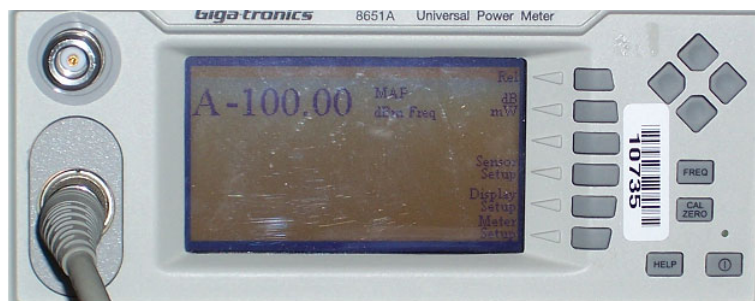
a. Channel values shown are at the center of the corresponding bands.

b. Either 15 (WCDMA1900A) or 16 (WCDMA1900B) may be used for testing.

To test the DUT's transmitter path:

Note: This procedure describes steps using the "Power Meter: Gigatronics 8651A" (with Option 12 and Power Sensor 80701A).

1. Set up the power meter:



- a. Make sure the meter has been given sufficient time to warm up, if necessary, to enable it to take accurate measurements.
 - b. Zero-calibrate the meter.
 - c. Enable MAP mode.
2. Prepare the DUT using the following AT commands (adjusting the band, channel, bandwidth, modulation, RB allocation, NS, and power level as necessary):
- a. **AT+ENTERCND=<password>** (Unlock extended AT command set.)
 - b. **AT+IDAFTMACT** (Enter test mode.)
 - c. **AT+IDASBAND=<bandValue>** (Set frequency band (e.g. 34 for LTE B1).
 - See [Table 14-4 on page 140](#) or [Table 14-5 on page 140](#) for appropriate <bandValue> values.
 - d. **AT+IDALSTXBW=3** (Set Tx bandwidth to 10 MHz.)
 - e. **AT+IDALSRXBW=3** (Set Rx bandwidth to 10 MHz.)
 - f. **AT+IDASCHAN=<channel>** (Set modem channel (e.g. 18300 for LTE B1).
 - See [Table 14-4 on page 140](#) or [Table 14-5 on page 140](#) for appropriate <channel> values.
 - g. **AT+IDALSTXMOD=0** (Set Tx modulation type to QPSK.)
 - h. **AT+IDALSWAVEFORM=1,12,0,19** (Set the Tx waveform characteristics. Make sure to set the correct resource block allocation (2nd parameter) appropriately. For example, 12 is used to produce max power—refer to 3GPP 36.521 table for Maximum Power Reduction (MPR) for Power Class 3 for more information.)
 - i. **AT+IDALSNSVAL=1** (Set the LTE NS (Net Sig) value.)
 - j. **AT+IDASTXON** (Turn on the transmitter. Note that the transmitter will put out the last power level that was programmed.)
 - k. **AT+IDALSTXPWR=1,10** (Begin transmitting at requested power level.)
 - l. Take the measurement.
 - m. Repeat steps k–l with different power levels if desired.
 - n. **AT+IDALSTXPWR=0,0** (Reduce Tx power to 0, so next time transmitter is turned on, it will come on with 0 dBm power.)
 - o. **AT+IDASTXOFF** (Turn off the transmitter.)

3. Test limits—Run ten or more good DUTs through this test procedure to obtain a nominal output power value.
 - Apply a tolerance of ± 5 to 6 dB to each measurement (assuming a good setup design).
 - Monitor these limits during mass-production ramp-up to determine if further adjustments are needed.

Note: The module has a nominal output power of +23 dBm ± 1 dB in LTE mode. However, the value measured by the power meter is significantly influenced (beyond the stated ± 1 dB output power tolerance) by the test setup (host RF cabling loss, antenna efficiency and pattern, test antenna efficiency and pattern, and choice of shield box).

Note: When doing the same test over the air in an RF chamber, values are likely to be significantly lower.

14.6 UMTS (WCDMA) RF Receive Path Test

Note: This procedure segment is performed in [Step 14](#) of the [Production Test Procedure on page 135](#).

The suggested test procedure that follows uses the parameters in the following tables.

Table 14-6: Test Settings—WP7502 UMTS Receive Path

	Band #	Frequency ^a (MHz)	Band ID	Rx Channel ^b
2100 MHz	Band 1	2141.20	9	9750
900 MHz	Band 8	948.60	29	2787

- a. Receive frequencies shown are 1.2 MHz offset from center
- b. Channel values shown are at the center of the corresponding bands.

Table 14-7: Test Settings—WP7504 UMTS Receive Path

	Band #	Frequency ^a (MHz)	Band ID	Rx Channel ^b
1900 MHz	Band 2	1961.20	15 ^c	9400
1700 MHz	Band 4	2133.20	28	1412
850 MHz	Band 5	882.60	22	4182

- a. Receive frequencies shown are 1.2 MHz offset from center
- b. Channel values shown are at the center of the corresponding bands.
- c. Either 15 (WCDMA1900A) or 16 (WCDMA1900B) may be used for testing.

Table 14-8: Test Settings—WP8548 UMTS Receive Path

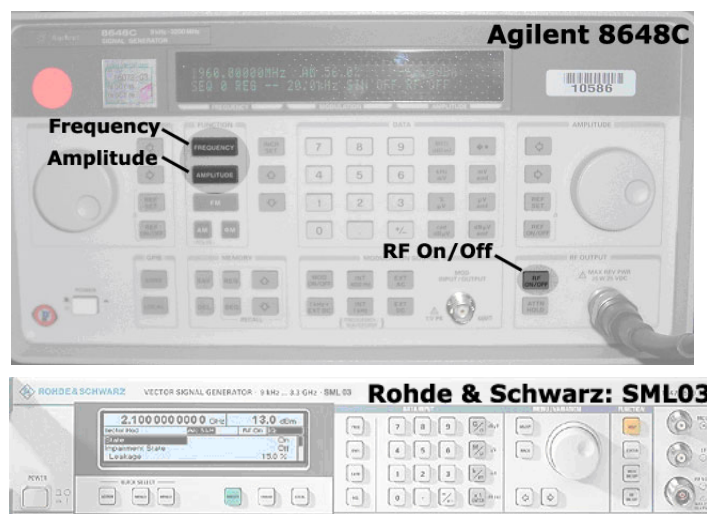
	Band #	Frequency ^a (MHz)	Band ID	Rx Channel ^b
2100 MHz	Band 1	2141.20	9	9750
1900 MHz	Band 2	1961.20	15 ^c	9400
850 MHz	Band 5	882.60	22	4182
900 MHz	Band 8	948.60	29	2787

- Receive frequencies shown are 1.2 MHz offset from center
- Channel values shown are at the center of the corresponding bands.
- Either 15 (WCDMA1900A) or 16 (WCDMA1900B) may be used for testing.

To test the DUT's receive path:

Note: This procedure describes steps using the Agilent 8648C signal generator—the Rohde & Schwarz SML03 is shown for reference only.

- Set up the signal generator:



- Set the amplitude to:
 - 80 dBm
 - Set the frequency for the band being tested. See [Table 14-6 on page 142](#), [Table 14-7 on page 142](#), or [Table 14-8 on page 143](#) for frequency values.
- Set up the DUT:
 - ATIENTERCND="<password>" (Unlock extended AT command set.)
 - ATIDAFTMACT (Put modem into factory test mode.)
 - ATIDASBAND=<band> (Set frequency band.)
 - See [Table 14-6 on page 142](#), [Table 14-7 on page 142](#), or [Table 14-8 on page 143](#) for <band> values.
 - ATIDASCHAN=<channel> (Set modem channel)
 - See [Table 14-6 on page 142](#), [Table 14-7 on page 142](#), or [Table 14-8 on page 143](#) for <channel> values.
 - ATIDASLNAGAIN=0 (Set the LNA to maximum gain.)

f. ATIDAWGAVGAGC=9400,0 (For PCS1900, channel 9400 as an example.)

The returned value is the RSSI in dBm.

- 3. Test limits**—Run ten or more good DUTs through this test procedure to obtain a nominal received power value.
- Apply a tolerance of ± 5 to 6 dB to each measurement (assuming a good setup design).
 - Make sure the measurement is made at a high enough level that it is not influenced by DUT-generated and ambient noise.
 - The Signal Generator power level can be adjusted and new limits found if the radiated test needs greater signal strength.
 - Monitor these limits during mass-production ramp-up to determine if further adjustments are needed.

Note: The value measured from the DUT is significantly influenced by the test setup and DUT design (host RF cabling loss, antenna efficiency and pattern, test antenna efficiency and pattern, and choice of shield box).

- 4. (WP75xx only) Test diversity paths:**
- a.** Set up the signal generator as in [Step 1](#).

Note: Setup of the DUT is the same as in [Step 2](#), except for a change to ATIDAWGAVGAGC and the addition of ATIDAWSSCHAIN.

- b.** Set up the DUT:
 - i.** ATIENTERCND=<password> (Unlock extended AT command set.)
 - ii.** ATIDAFTMACT (Put modem into factory test mode.)
 - iii.** ATIDASBAND=<band> (Set frequency band.)
 - See [Table 14-6 on page 142](#), [Table 14-7 on page 142](#), or [Table 14-8 on page 143](#) for <band> values
 - iv.** ATIDAWSSCHAIN=1 (Enable the secondary chain.)
 - v.** ATIDASCHAN=<channel> (Set modem channel)
 - See [Table 14-6 on page 142](#), [Table 14-7 on page 142](#), or [Table 14-8 on page 143](#) for <channel> values
 - vi.** ATIDASLNAGAIN=0 (Set the LNA to maximum gain.)
 - vii.** ATIDAWGAVGAGC=9400,0,1 (The '1' indicates the diversity path is used.)
- c.** Test the limits as in [Step 3](#).

14.7 LTE RF Receive Path Test (WP75xx)

Note: This procedure segment is performed in [Step 14](#) of the [Production Test Procedure](#) on [page 135](#).

The suggested test procedure that follows uses the parameters in [Table 14-9](#) and [Table 14-10](#).

Table 14-9: Test Settings — WP7502 LTE Receive Path

	Band #	Frequency ^a (MHz)	Band ID	Rx Channel ^b
2100 MHz	Band 1	2142.00	34	18300
1800 MHz	Band 3	1844.50	44	19575
2600 MHz	Band 7	2657.00	35	21100
900 MHz	Band 8	944.50	47	21625
800 MHz	Band 20	808.00	56	24300

- a. Receive frequencies shown are 2 MHz offset from center
- b. Channel values shown are at the center of the corresponding bands.

Table 14-10: Test Settings — WP7504 LTE Receive Path

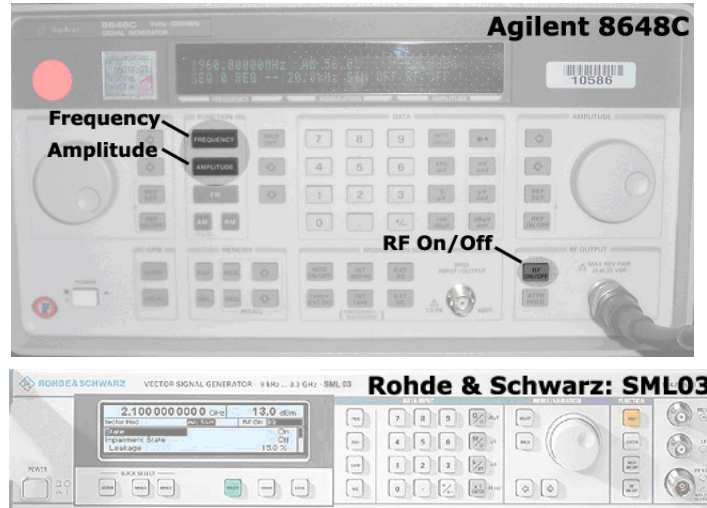
	Band #	Frequency ^a (MHz)	Band ID	Rx Channel ^b
1900 MHz	Band 2	1962.00	43	18900
1700 MHz	Band 4	2134.50	42	20175
850 MHz	Band 5	883.50	45	20525
700 MHz	Band 12	739.50	50	23095
700 MHz	Band 17	742.00	37	23790
1900 MHz (G Block)	Band 25	1964.50	61	26365
850 MHz	Band 26	878.50	62	26865

- a. Receive frequencies shown are 2 MHz offset from center
- b. Channel values shown are at the center of the corresponding bands.

To test the DUT's receive path (or diversity path, while connected to the diversity antenna):

Note: This procedure describes steps using the Agilent 8648C signal generator—the Rohde & Schwarz SML03 is shown for reference only.

1. Set up the signal generator:



- a. Set the amplitude to -70 dBm
 - b. Set the frequency for the band being tested. See [Table 14-9](#) or [Table 14-10](#) for frequency values.
2. Set up the DUT:
 - a. ATIENTERCND="**<password>**" (Unlock extended AT command set.)
 - b. ATIDAFTMACT (Put modem into factory test mode.)
 - c. ATIDASBAND=**<band>** (Set frequency band.)
 - See [Table 14-9](#) or [Table 14-10](#) for **<band>** values.
 - d. ATIDALSRXBW=2 (Set Rx LTE bandwidth to 5MHz.)
 - e. ATIDALSTXBW=2 (Set Tx LTE bandwidth to 5MHz.)
 - f. ATIDASCHAN=**<channel>** (Set modem channel)
 - See [Table 14-9](#) or [Table 14-10](#) for **<channel>** values.
 - g. ATIDALGAVGAGC=**<channel>**,0 (Get averaged Rx AGC)
 - See [Table 14-9](#) or [Table 14-10](#) for **<channel>** values.
3. Test limits—Run ten or more good DUTs through this test procedure to obtain a nominal received power value.
 - Apply a tolerance of ± 5 to 6 dB to each measurement (assuming a good setup design).
 - Make sure the measurement is made at a high enough level that it is not influenced by DUT-generated and ambient noise.
 - The Signal Generator power level can be adjusted and new limits found if the radiated test needs greater signal strength.
 - Monitor these limits during mass-production ramp-up to determine if further adjustments are needed.

Note: The value measured from the DUT is significantly influenced by the test setup and DUT design (host RF cabling loss, antenna efficiency and pattern, test antenna efficiency and pattern, and choice of shield box).

14.8 GNSS RF Receive Path Test

The GNSS receive path uses the dedicated GNSS connector.

To test the GNSS receive path:

1. Inject a carrier signal at -110dBm, frequency 1575.52 MHz into the GNSS Rx path at the connector. (Note that this frequency is 100 kHz higher than the actual GPS L1 center frequency.)
2. Test the signal carrier-to-noise level at the GNSS receiver:
 - a. **ATIINTERCND=<password>** (Unlock extended AT command set.)
 - b. **ATIDAFTMACT** (Put modem into factory test mode.)
 - c. **ATIDACGPSTESTMODE=1** (Start CGPS diagnostic task.)
 - d. **ATIDACGPSSTANDALONE=1** (Enter standalone RF mode.)
 - e. **ATIDACGPSMASKON** (Enable log mask.)
 - f. **ATIDACGPSCTON** (Return signal-to-noise and frequency measurements.)
 - g. Repeat **ATIDACGPSCTON** five to ten times to ensure the measurements are repeatable and stable.
3. Leave the RF connection to the embedded module intact, and turn off the signal generator.
4. Take several more **IDACGPSCTON** readings. This will demonstrate a 'bad' signal in order to set limits for testing, if needed. This frequency offset should fall outside of the guidelines in the note below, which indicates that the CtoN result is invalid.
5. (Optional) Turn the signal generator on again, and reduce the level to -120dBm. Take more **IDACGPSCTON** readings and use these as a reference for what a marginal/poor signal would be.

*Note: The response to **ATIDACGPSCTON** for a good connection should show CtoN within 58 +/- 5dB and Freq (frequency offset) within 100000 Hz +/- 5000 Hz.*

>> 15: Safety Recommendations (For Information Only)

For the efficient and safe operation of your GSM application based on the AirPrime WP75xx Embedded Module/AirPrime WP8548 Embedded Module, please read the following RF safety information carefully.

15.1 RF Safety

15.1.1 General

Your GSM terminal is based on the GSM standard for cellular technology. The GSM standard is spread all over the world. It covers Europe, Asia and some parts of America and Africa. This is the most used telecommunication standard.

Your GSM terminal is actually a low power radio transmitter and receiver. It sends out as well as receives radio frequency energy. When you use your GSM application, the cellular system which handles your calls controls both the radio frequency and the power level of your cellular modem.

15.1.2 Exposure to RF Energy

There has been some public concern about possible health effects of using GSM terminals. Although research on health effects from RF energy has focused on the current RF technology for many years, scientists have begun research regarding newer radio technologies, such as GSM. After existing research had been reviewed, and after compliance to all applicable safety standards had been tested, it has been concluded that the product was fitted for use.

If you are concerned about exposure to RF energy, there are things you can do to minimize exposure. Obviously, limiting the duration of your calls will reduce your exposure to RF energy. In addition, you can reduce RF exposure by operating your cellular terminal efficiently by following the guidelines below.

15.1.3 Efficient Terminal Operation

For your GSM terminal to operate at the lowest power level, consistent with satisfactory call quality:

- If your terminal has an extendable antenna, extend it fully. Some models allow you to place a call with the antenna retracted. However your GSM terminal operates more efficiently with the antenna when it is fully extended.
- Do not hold the antenna when the terminal is "IN USE". Holding the antenna affects call quality and may cause the modem to operate at a higher power level than needed.

15.1.4 Antenna Care and Replacement

Do not use the GSM terminal with a damaged antenna. If a damaged antenna comes into contact with the skin, a minor burn may result. Replace a damaged antenna immediately. You may repair antenna to yourself by following the instructions provided to you. If so, use only a manufacturer-approved antenna. Otherwise, have your antenna repaired by a qualified technician.

Buy or replace the antenna only from the approved suppliers list. Using unauthorized antennas, modifications or attachments could damage the terminal and may contravene local RF emission regulations or invalidate type approval.

15.2 General Safety

15.2.1 Driving

Check the laws and the regulations regarding the use of cellular devices in the area where you have to drive as you always have to comply with them. When using your GSM terminal while driving, please:

- Give full attention to driving,
- Pull off the road and park before making or answering a call if driving conditions so require.

15.2.2 Electronic Devices

Most electronic equipment, for example in hospitals and motor vehicles is shielded from RF energy. However, RF energy may affect some improperly shielded electronic equipment.

15.2.3 Vehicle Electronic Equipment

Check with your vehicle manufacturer representative to determine if any on-board electronic equipment is adequately shielded from RF energy.

15.2.4 Medical Electronic Equipment

Consult the manufacturer of any personal medical devices (such as pacemakers, hearing aids, etc...) to determine if they are adequately shielded from external RF energy.

Turn your terminal **OFF** in health care facilities when any regulations posted in the area instruct you to do so. Hospitals or health care facilities may be using RF monitoring equipment.

15.2.5 Aircraft

Turn your terminal OFF before boarding any aircraft.

- Use it on the ground only with crew permission.
- Do not use it in the air.

To prevent possible interference with aircraft systems, Federal Aviation Administration (FAA) regulations require you should have prior permission from a crew member to use your terminal while the aircraft is on the ground. To prevent interference with cellular systems, local RF regulations prohibit using your modem while airborne.

15.2.6 Children

Do not allow children to play with your GSM terminal. It is not a toy. Children could hurt themselves or others (by poking themselves or others in the eye with the antenna, for example). Children could damage the modem, or make calls that increase your modem bills.

15.2.7 Blasting Areas

To avoid interfering with blasting operations, turn your unit OFF when you are in a "blasting area" or in areas posted "turn off two-way radio". Construction crew often uses remote control RF devices to set off explosives.

15.2.8 Potentially Explosive Atmospheres

Turn your terminal OFF when in any area with a potentially explosive atmosphere. Though it is rare, but your modem or its accessories could generate sparks. Sparks in such areas could cause an explosion or fire resulting in bodily injuries or even death.

Areas with a potentially explosive atmosphere are often, but not always, clearly marked. They include fueling areas such as petrol stations; below decks on boats; fuel or chemical transfer or storage facilities; and areas where the air contains chemicals or particles, such as grain, dust, or metal powders.

Do not transport or store flammable gas, liquid, or explosives, in the compartment of your vehicle which contains your terminal or accessories.

Before using your terminal in a vehicle powered by liquefied petroleum gas (such as propane or butane) ensure that the vehicle complies with the relevant fire and safety regulations of the country in which the vehicle is used.