

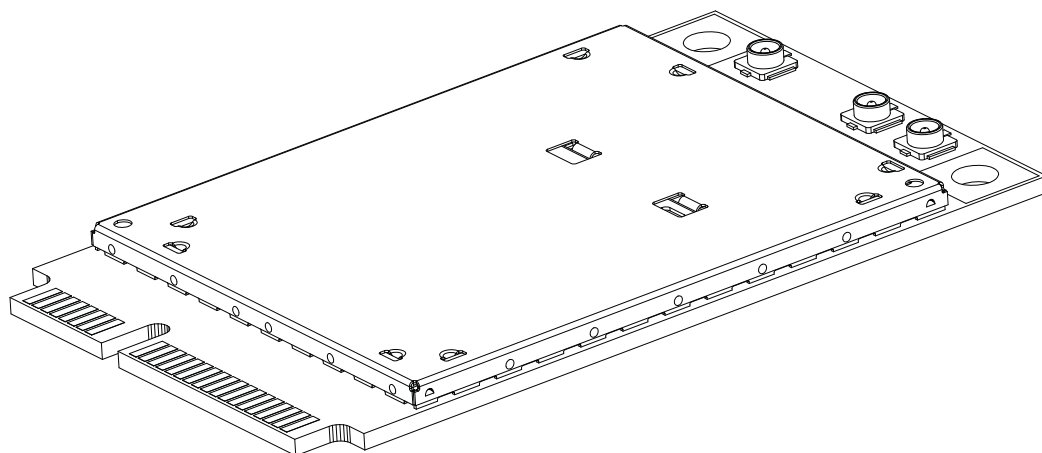

Product Technical Specification & Customer Design Guidelines

AirPrime MC7354



SIERRA
WIRELESS®

4114635

Rev 9

Proprietary and Confidential
Contents subject to change

Important Notice

Due to the nature of wireless communications, transmission and reception of data can never be guaranteed. Data may be delayed, corrupted (i.e., have errors) or be totally lost. Although significant delays or losses of data are rare when wireless devices such as the Sierra Wireless modem are used in a normal manner with a well-constructed network, the Sierra Wireless modem should not be used in situations where failure to transmit or receive data could result in damage of any kind to the user or any other party, including but not limited to personal injury, death, or loss of property. Sierra Wireless accepts no responsibility for damages of any kind resulting from delays or errors in data transmitted or received using the Sierra Wireless modem, or for failure of the Sierra Wireless modem to transmit or receive such data.

Safety and Hazards

Do not operate the Sierra Wireless modem in areas where blasting is in progress, where explosive atmospheres may be present, near medical equipment, near life support equipment, or any equipment which may be susceptible to any form of radio interference. In such areas, the Sierra Wireless modem **MUST BE POWERED OFF**. The Sierra Wireless modem can transmit signals that could interfere with this equipment.

Do not operate the Sierra Wireless modem in any aircraft, whether the aircraft is on the ground or in flight. In aircraft, the Sierra Wireless modem **MUST BE POWERED OFF**. When operating, the Sierra Wireless modem can transmit signals that could interfere with various onboard systems.

Note: Some airlines may permit the use of cellular phones while the aircraft is on the ground and the door is open. Sierra Wireless modems may be used at this time.

The driver or operator of any vehicle should not operate the Sierra Wireless modem while in control of a vehicle. Doing so will detract from the driver or operator's control and operation of that vehicle. In some states and provinces, operating such communications devices while in control of a vehicle is an offence.

Limitation of Liability

The information in this manual is subject to change without notice and does not represent a commitment on the part of Sierra Wireless. SIERRA WIRELESS AND ITS AFFILIATES SPECIFICALLY DISCLAIM LIABILITY FOR ANY AND ALL DIRECT, INDIRECT, SPECIAL, GENERAL, INCIDENTAL, CONSEQUENTIAL, PUNITIVE OR EXEMPLARY DAMAGES INCLUDING, BUT NOT LIMITED TO, LOSS OF PROFITS OR REVENUE OR ANTICIPATED PROFITS OR REVENUE ARISING OUT OF THE USE OR INABILITY TO USE ANY SIERRA WIRELESS PRODUCT, EVEN IF SIERRA WIRELESS AND/OR ITS AFFILIATES HAS BEEN ADVISED OF THE POSSIBILITY OF SUCH DAMAGES OR THEY ARE FORESEEABLE OR FOR CLAIMS BY ANY THIRD PARTY.

Notwithstanding the foregoing, in no event shall Sierra Wireless and/or its affiliates aggregate liability arising under or in connection with the Sierra Wireless product, regardless of the number of events, occurrences, or claims giving rise to liability, be in excess of the price paid by the purchaser for the Sierra Wireless product.

Patents

This product may contain technology developed by or for Sierra Wireless Inc. This product includes technology licensed from QUALCOMM®. This product is manufactured or sold by Sierra Wireless Inc. or its affiliates under one or more patents licensed from InterDigital Group and MMP Portfolio Licensing.

Copyright

©2016 Sierra Wireless. All rights reserved.

Trademarks

Sierra Wireless®, AirPrime®, AirLink®, AirVantage® and the Sierra Wireless logo are registered trademarks of Sierra Wireless, Inc.

Windows® and Windows Vista® are registered trademarks of Microsoft Corporation.

QUALCOMM® is a registered trademark of QUALCOMM Incorporated. Used under license.

Other trademarks are the property of their respective owners.

Contact Information

Sales information and technical support, including warranty and returns	Web: sierrawireless.com/company/contact-us/ Global toll-free number: 1-877-687-7795 6:00 am to 6:00 pm PST
Corporate and product information	Web: sierrawireless.com

Revision History

Revision number	Release date	Changes
1	September 2013	Initial release.
2	September 2013	Introduction wording. Updated humidity spec. Removed WMC DLL support statement.
3	April 2014	Updated voltage levels and/or pin type (WAKE_N, USIM_DATA, WAN_LED_N), current consumption, ANT_CTRL/GPIO and GPIO/DPR pin definitions. Temperature spec wording changes.
4	April 2014	Minor formatting fixes
5	June 2014	Updated temperature specification details in Table 7-1 on page 65 . Updated GSM, UMTS and LTE Rx frequency details in Testing chapter.
6	October 2014	Corrected IC cert #.
7	March 2015	Updated Table 4-11 on page 52 (# of satellites)

Revision number	Release date	Changes
8	November 2015	Added W_DISABLE_N to power on/off signal timing— Figure 5-2 on page 59 Added Required shutdown sequence on page 60 . Updated FCC/IC IDs, and antenna gains in list and table in Important compliance information for North American users on page 72 .
9	September 2016	Removed 1.3/3.0 MHz support for LTE Bands 2/4/5/25 (Table 4-2 on page 48).

»» Contents

Introduction	17
Supported RF bands	17
Physical features	18
Application interface features	18
Modem features	19
LTE features	19
Short Message Service (SMS) features	20
Position location (GNSS)	20
Warranty and support	20
Supporting documents	20
Accessories	21
Required connectors	21
Ordering information	21
Integration requirements	22
Standards Compliance	23
Electrical Specifications	25
Host interface pin assignments	27
Power supply	32
USB interface	32
USB high/full speed throughput performance	33
User-developed drivers	33
SIM interface	33
SIM implementation	35

Control interface (Signals)	36
WAKE_N — Wake host	36
W_DISABLE_N — Wireless disable	37
WAN_LED_N—LED output	37
SYSTEM_RESET_N—Reset Input	38
PCM/I2S Audio Interface	38
Antenna control	41
RF Specifications	43
RF connections	43
Shielding	43
Antenna and cabling	44
Ground connection	45
Interference and sensitivity	45
Interference from other wireless devices	45
Host-generated RF interference	46
Device-generated RF interference	46
Methods to mitigate decreased Rx performance	46
Radiated Spurious Emissions (RSE)	46
Radiated sensitivity measurement.	47
Sierra Wireless' sensitivity testing and desensitization investigation	47
Sensitivity vs. frequency	47
Supported frequencies.	47
Conducted Rx sensitivity / Tx power	50
GNSS specifications	52
Power	55
Power consumption	55
Module power states	57
Power state transitions	58

Power interface	59
Power ramp-up	59
Power-on/off timing	59
Transmit power waveform (GSM)	61
Power supply noise	61
SED (Smart Error Detection)	61
Tx power control	61
Software Interface	63
Support tools	63
USB interface	63
Mechanical and Environmental Specifications	65
Device views	66
Labeling	67
Electrostatic discharge (ESD)	68
Thermal considerations	68
Regulatory Compliance and Industry Certifications	71
Important notice	71
Safety and hazards	71
Important compliance information for North American users	72
Antenna Specification	75
Recommended GNSS antenna specifications	77
Antenna tests	77
Design Checklist	79
Testing	81
AT command entry timing requirement	81

Acceptance testing	81
Acceptance test requirements	82
Acceptance test procedure	82
Certification testing	82
Production testing	83
Functional production test	83
Production test procedure	84
UMTS (WCDMA/GSM) RF transmission path test	87
UMTS (WCDMA/GSM) RF receive path test	89
LTE RF receive path test	91
GNSS RF receive path test	92
Quality assurance testing	93
Suggested testing equipment	93
Testing assistance provided by Sierra Wireless	94
IOT/Operator testing	94
Extended AT commands for testing.	94
Packaging	97
References	99
Sierra Wireless documents	99
Command documents	99
Other Sierra documents	99
Industry/other documents	99
Technology Overview	101
LTE	101
CDMA	101
1xEV-DO	101
1X and IS-95A	102
UMTS.	102
HSPA.	103

HSPA+	103
DC-HSPA+	103
GPRS / EGPRS	103
Acronyms	105

List of Tables

Table 1-1: Supported RF bands	17
Table 1-2: Modem features	19
Table 1-3: Required host-module connectors	21
Table 2-1: Standards compliance	23
Table 3-1: Connector pin assignments	28
Table 3-2: Power and ground specifications	32
Table 3-3: USB interface	32
Table 3-4: SIM interface signal	33
Table 3-5: Module control signals	36
Table 3-6: PCM/I2S Interface signals	38
Table 3-7: PCM Timing	39
Table 3-8: I2S master transmitter timing,	40
Table 3-9: Antenna control signals	41
Table 4-1: LTE frequency band support	48
Table 4-2: LTE bandwidth support.	48
Table 4-3: WCDMA frequency band support.	48
Table 4-4: GSM frequency band support.	49
Table 4-5: CDMA frequency band support	49
Table 4-6: Conducted Rx (Receive) sensitivity—LTE bands	50
Table 4-7: Conducted Rx (Receive) sensitivity—CDMA bands	50
Table 4-8: Conducted Rx (Receive) sensitivity—UMTS bands.	51
Table 4-9: Conducted Rx (Receive) sensitivity—GSM/EDGE bands.	51
Table 4-10: Conducted Tx (Transmit) power tolerances	51
Table 4-11: GNSS specifications.	52
Table 5-1: Averaged standby DC power consumption	55
Table 5-2: Averaged call mode DC power consumption	56
Table 5-3: Miscellaneous DC power consumption	57
Table 5-4: Module power states	57

Table 5-5: Power state transitions (including voltage/temperature trigger levels)	58
Table 5-6: Power-on timing parameters (double enumeration).	60
Table 5-7: Power-on timing parameters (single enumeration)	60
Table 5-8: Power-off timing parameters	60
Table 5-9: Dynamic power control of SAR backoff state.	62
Table 7-1: Mechanical and environmental specifications	65
Table 8-1: Collocated configuration specifications	73
Table A-1: Antenna requirements	75
Table A-2: GNSS standalone antenna requirements	77
Table B-1: Hardware integration design considerations	79
Table C-1: Test settings—UMTS transmission path	87
Table C-2: Test settings—WCDMA/GSM receive path	89
Table C-3: Test settings—LTE receive path.	91
Table C-4: Extended AT commands.	94
Table F-1: EGPRS power backoff.	104
Table G-1: Acronyms and definitions	105

»» | List of Figures

Figure 3-1: System block diagram	26
Figure 3-2: Expanded RF block diagram	27
Figure 3-3: SIM application interface	34
Figure 3-4: SIM card contacts (contact view)	34
Figure 3-5: Recommended WAKE_N connection	36
Figure 3-6: Recommended wireless disable connection	37
Figure 3-7: Example LED	38
Figure 3-8: PCM_SYNC timing	39
Figure 3-9: Timing—PCM_CODEC to Module	39
Figure 3-10: Timing—Module to PCM_CODEC	39
Figure 3-11: I2S transmitter timing	40
Figure 4-1: Module connectors	43
Figure 5-1: Voltage/temperature monitoring state machines	59
Figure 5-2: Signal timing (Power-on, USB enumeration, and power-off).	59
Figure 5-3: GSM transmit power waveform (class 10 operation)	61
Figure 7-1: Top view	66
Figure 7-2: Dimensioned view	67
Figure 7-3: Sample unit label.	67
Figure 7-4: Shield locations	68
Figure 4-1: Device placement in module tray	97
Figure 4-2: Shipping package	97

1: Introduction

The Sierra Wireless MC7354 PCI Express Mini Card is a compact, lightweight, wireless LTE-, UMTS-, and CDMA-based modem.

The MC7354 provides LTE, DC-HSPA+, HSPA+, HSDPA, HSUPA, WCDMA, GSM, GPRS, EDGE, CDMA, and GNSS connectivity for networking, and M2M applications over several radio frequency bands. The device also supports 2G/3G roaming, subject to network operator provisioning.

The device is designed to be network operator-certified. Contact Sierra Wireless for details.

Supported RF bands

The modem, based on Qualcomm's MDM9615 baseband processor, supports data operation on LTE, DC-HSPA+, HSPA+, EDGE, GPRS, GSM, and CDMA networks.

Table 1-1: Supported RF bands

Technology	Bands	Notes	Data rates
LTE	<ul style="list-style-type: none"> Band 2 (1900 MHz) Band 4 (AWS) (1700/2100 MHz) Band 5 (850 MHz) Band 13 (700 MHz) Band 17 (700 MHz) Band 25 (1900 MHz) 	MIMO support	Category 3 <ul style="list-style-type: none"> Downlink: <ul style="list-style-type: none"> 100 Mbps (20 MHz bandwidth) 50 Mbps (10 MHz bandwidth) Uplink: <ul style="list-style-type: none"> 50 Mbps (20 MHz bandwidth) 25 Mbps (10 MHz bandwidth)
CDMA EVDO Release 0 and EVDO Release A	<ul style="list-style-type: none"> BC0 (Cellular 800 MHz) BC1 (PCS 1900 MHz) BC10 (Secondary 800 MHz) 	Diversity support	CDMA IS-856 (1xEV-DO Release A) <ul style="list-style-type: none"> Up to 3.1 Mbps forward channel Up to 1.8 Mbps reverse channel CDMA IS-2000 <ul style="list-style-type: none"> Up to 153 kbps, simultaneous forward and reverse channel Circuit-switched data bearers up to 14.4 kbps
UMTS (WCDMA) HSDPA HSUPA HSPA+ DC-HSPA+	<ul style="list-style-type: none"> Band 1 (2100 MHz) Band 2 (1900 MHz) Band 4 (AWS 1700/2100 MHz) Band 5 (850 MHz) Band 8 (900 MHz) 	Diversity support	HSPA+ rates <ul style="list-style-type: none"> Downlink: Up to 42 Mbps (category 24) Uplink: Up to 5.76 Mbps (category 6)

Table 1-1: Supported RF bands (Continued)

Technology	Bands	Notes	Data rates
GSM GPRS EDGE	<ul style="list-style-type: none"> GSM 850 (850 MHz) EGSM 900 (900 MHz) DCS 1800 (1800 MHz) PCS 1900 (1900 MHz) 		EDGE throughput up to 236 kbps
GNSS	<ul style="list-style-type: none"> GPS: 1575.42 MHz GLONASS: 1602 MHz 		

Physical features

- Small form factor—conforms to type F2 as specified in *PCI Express Mini Card Electromechanical Specification Revision 1.2*.
- Temperature
 - Operating temperature range (Class A): -30°C to +70°C
 - Operating temperature range (Class B): -40°C to +85°C

Important: *The internal module temperature must be kept below 100°C. For best performance, the internal module temperature should be kept below 85°C. Proper mounting, heat sinks, and active cooling may be required, depending on the integrated application.*

Application interface features

- USB interface (QMI) for Windows 7 and legacy Windows operating systems
- MBIM for Windows 8
- USB Link Power Management (LPM2) combined with selective suspend to maximize power savings. Also supports fast wakeup.
- AT command interface ([1] *AT Command Set for User Equipment (UE) (Release 6) (Doc# 3GPP TS 27.007)*, plus proprietary extended AT commands in [2] *AirPrime MiniCard MC73xx/MC8805 AT Command Reference (Doc# 4114486)*)
- Software Development Kits (SDK) for Windows 7 and Windows 8
- Linux SDK, including a Linux API (Application Program Interface)
- OMA DM (Open Mobile Alliance Device Management)
- FOTA (Firmware Over The Air)
- QDL loader compliant
- Support for active antenna control via dedicated antenna control signals (ANT_CTRL0:2)
- Dynamic power reduction support via software and dedicated signal (DPR)

Note: Dial-up networking (DUN) is not supported.

Note: OMA DM and FOTA support is operator-dependent.

Modem features

Table 1-2: Modem features

- CDMA (EVDO)/LTE/DC-HSPA+/HSPA+/HSPA/UMTS (WCDMA)/EDGE/GPRS operation
- Multiple (up to 16) cellular packet data profiles
- Traditional modem COM port support for AT commands
- USB suspend/resume
- Sleep mode for minimum idle power draw
- SIM application tool kit with proactive SIM commands
- Enhanced Operator Name String (EONS)
- Automatic GPRS attach at power-up
- GPRS detach
- GPRS detach only
- Combined GPRS / IMSI detach; MS-initiated and network-initiated detach
- Mobile-originated PDP context activation / deactivation
- Support QoS profile
 - Release 99 QoS negotiation—Background, Interactive, and Streaming
 - Release 97—Precedence Class, Reliability Class, Delay Class, Peak Throughput, Mean Throughput
- Static and Dynamic IP address. The network may assign a fixed IP address or dynamically assign one using DHCP (Dynamic Host Configuration Protocol).
- PAP and CHAP support
- PDP context type (IPv4, IPv6, or IPv4v6). IP Packet Data Protocol context.
- RFC1144 TCP/IP header compression
- Interaction with existing GSM services (MO / MT SMS) while:
 - GPRS is attached, or
 - In a GPRS data session (class B GPRS suspend / resume procedures)

LTE features

- Basic cell selection and system acquisition
 - PSS/SSS/MIB decode
 - SIB1–SIB12 decoding
- NAS/AS security procedures
 - Snow 3G/AES security
- CQI/RI/PMI reporting
- Paging procedures
 - Paging in Idle and Connected mode

- Dedicated bearer
 - Network-initiated dedicated bearer
 - [UE](#)-initiated dedicated bearer
- Multiple PDN connections (IPv4 and IPv6 combinations), subject to operating system support. (For example, not supported in Windows 8.)
- Connected mode intra-LTE mobility
- Idle mode intra-LTE mobility
- iRAT between LTE/2G
iRAT between LTE/3G for idle and connection release with redirection
- Detach procedure
 - Network-initiated detach with reattach required
 - Network-initiated detach followed by connection release
- LTE → [eHRPD](#) redirection with data continuity (IPv4/IPv6)

Short Message Service (SMS) features

- Mobile-terminated [SMS](#) for CDMA and UMTS
- Mobile-originated SMS for CDMA and UMTS
- SMS over SGs (LTE)
- Mobile-terminated SMS over [IMS](#) for LTE/eHRPD
- Mobile-terminated SMS over GPRS/UMTS/HSPA/HRPD/1xRTT

Position location (GNSS)

- Concurrent standalone GPS and GLONASS
- Assisted GPS (A-GPS) SUPL1.0
- Assisted [GNSS](#) (A-GNSS) SUPL2.0
- gpsOneXTRA 2.0 with GPS + GLONASS support
- GNSS on dedicated connector or diversity connector
- DC bias on GNSS connector to support an external active GNSS antenna

Warranty and support

The MC7354 offers the following support features:

- Standard 1-year warranty
- Enabling software (drivers, [SDK](#), etc.) for Android RIL (Radio Interface Layer) v4.0 (Ice Cream Sandwich) and later, Linux, Windows 7, and Windows 8

Supporting documents

Several additional documents describe Mini Card design, usage, integration, and other features. See [References on page 99](#).

Accessories

The Universal Development Kit (UDK) is a hardware development platform for AirPrime MC-series modules. It contains hardware components for evaluating and developing with the module, including:

- Development board
- Cables
- Antennas (Additional antennas may be required to support all bands.)
- Initial allotment of support hours
- Other accessories

For instructions on setting up the UDK (part number 6000270), see [3] *PCI Express Mini Card Dev Kit Quick Start Guide (Doc# 2130705)*.

For over-the-air LTE testing, ensure that suitable antennas are used. (Two antennas are required for this testing; Sierra Wireless offers an LTE-capable antenna covering 700–2600 MHz BW—please order part number 6000492 (Qty 1—this contains two antennas).)

Required connectors

[Table 1-3](#) describes the connectors used to integrate AirPrime MC-series modules into your host device.

Table 1-3: Required host-module connectors¹

Connector type	Description
RF cables	<ul style="list-style-type: none"> • Mate with Hirose U.FL connectors (model U.FL #CL331-0471-0-10) • Three connector jacks (Note: The UDK has two connector jacks.)
EDGE (52-pin)	<ul style="list-style-type: none"> • Industry-standard mating connector • Some manufacturers include Tyco, Foxconn, Molex • Example: UDK board uses Molex 67910-0001
SIM	<ul style="list-style-type: none"> • Industry-standard connector. Type depends on how host device exposes the SIM socket • Example: UDK board uses ITT CCM03-3518

1. Manufacturers/part numbers are for reference only and are subject to change. Choose connectors that are appropriate for your own design.

Ordering information

To order, contact the Sierra Wireless Sales Desk at +1 (604) 232-1488 between 8 AM and 5 PM Pacific Time.

Integration requirements

Sierra Wireless provides, in the document suite, guidelines for successful Mini Card integration and offers integration support services as necessary.

When integrating the MC7354 PCI-Express Mini Card, the following items need to be addressed:

- **Mounting**—Effect on temperature, shock, and vibration performance
- **Power supply**—Impact on battery drain and possible [RF](#) interference
- **Antenna location and type**—Impact on RF performance
- **Regulatory approvals**—As discussed in [Regulatory Compliance and Industry Certifications on page 71](#).
- **Service provisioning**—Manufacturing process
- **Software**—As discussed in [Software Interface on page 63](#).
- **Host Interface**—Compliance with interface voltage levels

2: Standards Compliance

The MC7354 Mini Card complies with the mandatory requirements described in the following standards. The exact set of requirements supported is network operator-dependent.

Table 2-1: Standards compliance

Technology	Standards
LTE	<ul style="list-style-type: none"> 3GPP Release 9
CDMA	<ul style="list-style-type: none"> TIA/EIA/IS-2000.1 through .6. <i>cdma2000® Standards for Spread Spectrum Systems. Release 0.</i> April 2000 TIA/EIA/IS-2000.1-1 through .6-1. <i>cdma2000® Addendum 1.</i> April 2000 TIA/EIA/IS-2000.1-2 through .6-2. <i>cdma2000® Addendum 2.</i> June 2001 TIA/EIA/IS-95-B. <i>Mobile Station-Base Station Compatibility Standard for Dual-Mode Spread Spectrum Systems.</i> December 4, 1998 TIA/EIA/IS-. <i>cdma2000® High Rate Packet Data Air Interface Specification.</i> November 2000
UMTS	<ul style="list-style-type: none"> 3GPP Release 5 3GPP Release 6 3GPP Release 7 3GPP Release 8
GSM/GPRS/EDGE	<ul style="list-style-type: none"> 3GPP Release 99 GERAN Feature Package #1

3: Electrical Specifications

The system block diagram in [Figure 3-1 on page 26](#) represents the MC7354 module integrated into a host system. The module includes the following interfaces to the host:

- **Power**—Supplied to the module by the host.
- **W_DISABLE_N**—Active low input from a hardware switch to the MC7354 that disables the main RF radio.
- **WAKE_N**—Signal used to wake the host when specific events occur.
- **WAN_LED_N**—Active-low **LED** drive signal provides an indication of RADIO ON state, either WAN or GNSS.
- **SYSTEM_RESET_N**—Active-low reset input.
- **Antenna**—Three U.FL **RF** connectors (one for Rx/Tx, one for Rx only, and one for GNSS). For details, see [RF Specifications on page 43](#).

Note that GNSS can use either the dedicated GNSS port, or the diversity/**MIMO** port.

- **SIM**—Supported through the interface connector. The **SIM** cavity / connector must be placed on the host device for this feature.
- **USB**—Interface to the host for data, control, and status information.
- **Antenna control**—Three signals that can be used to control external antenna switches.
- **Dynamic power control**—Signal used to adjust Tx power to meet FCC SAR requirements. For details, see [Tx power control on page 61](#).
- **PCM/I²S audio interface**—PCM or Inter-IC Sound (I²S) serial bus for digital audio.

The MC7354 has two main interface areas—the host I/O connector and the **RF** ports. Details of these interfaces are described in the sections that follow.

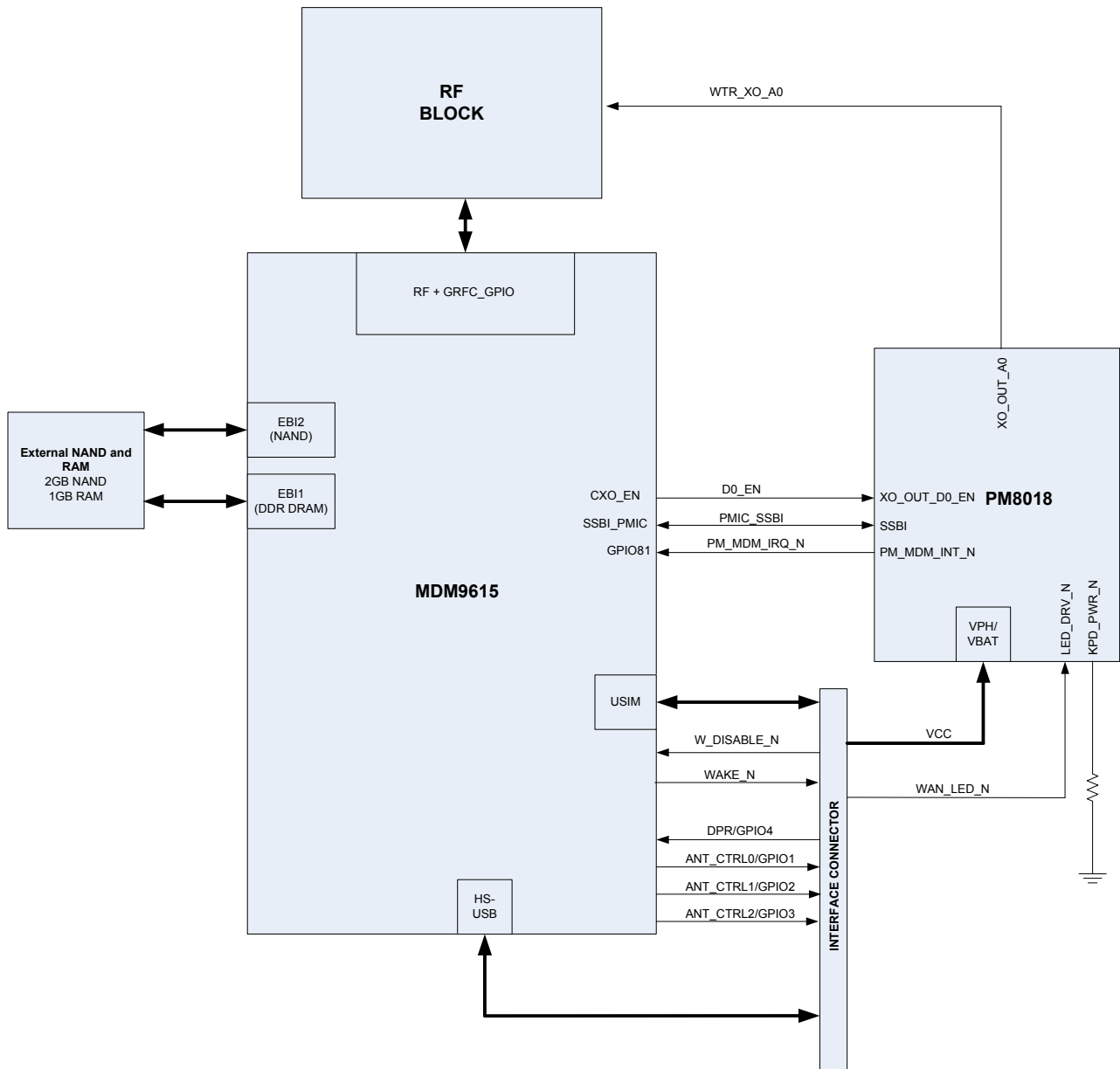

Figure 3-1: System block diagram

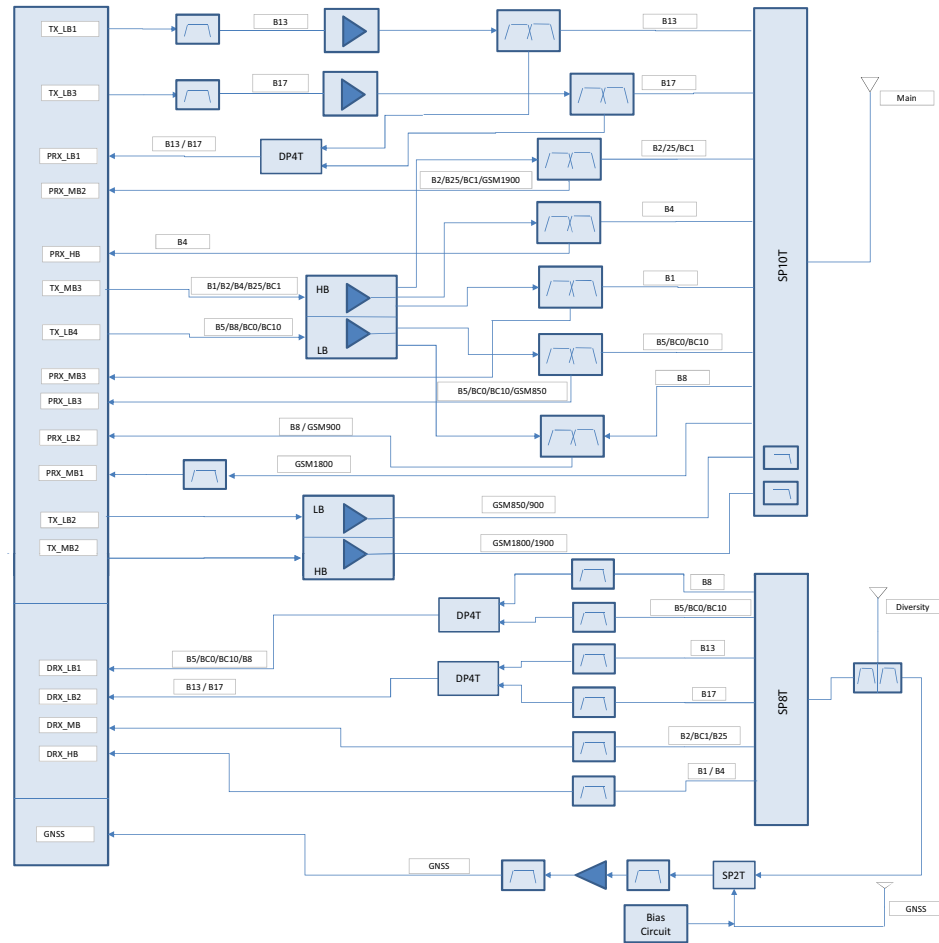

Figure 3-2: Expanded RF block diagram

Host interface pin assignments

The MC7354 host I/O connector provides pins for power, serial communications, and control. Pin assignments are listed in [Table 3-1](#). See the following tables for pin details based on interface types:

- [Table 3-2, Power and ground specifications](#), on page 32
- [Table 3-3, USB interface](#), on page 32
- [Table 3-4, SIM interface signal](#), on page 33
- [Table 3-5, Module control signals](#), on page 36

Note: On any given interface (USB, SIM, etc.), leave unused inputs and outputs as no-connects.

Note: The following table describes the **internal** structure of the module.

Table 3-1: Connector pin assignments¹

Pin	Signal name	Pin type ²	Description	Direction to module	Active state	Voltage levels (V)		
						Min	Typ	Max
1	WAKE_N	OC	Wake host	Output	Low	-	-	0.10
2	VCC	V	Power supply	Input	Power	3.00	3.30	3.60
3	ANT_CTRL0 / GPIO1	-	(ANT_CTRL0) Customer-defined external switch control for multiple antennas	Output	High	1.35	-	1.90
				Output	Low	0	-	0.45
			(GPIO1) General purpose I/O	Input High		1.17	1.80	2.10
				Input Low		-0.30		0.63
				Output High		1.35	1.80	1.90
				Output Low		0.00		0.45
4	GND	V	Ground	Input	Power	-	0	-
5	ANT_CTRL1 / GPIO2	-	(ANT_CTRL1) Customer-defined external switch control for multiple antennas	Output	High	1.35	-	1.90
				Output	Low	0	-	0.45
			(GPIO2) General purpose I/O	Input High		1.17	1.80	2.10
				Input Low		-0.30		0.63
				Output High		1.35	1.80	1.90
				Output Low		0.00		0.45
6	NC	-	No connect	-	-	-	-	-
7	NC	-	No connect	-	-	-	-	-
8	USIM_PWR	-	SIM VCC supply	Output	Power	2.75 (3V SIM) 1.75 (1.8V SIM)	2.85 (3V SIM) 1.80 (1.8V SIM)	3.05 (3V SIM) 1.85 (1.8V SIM)
9	GND	V	Ground	Input	Power	-	0	-
10	USIM_DATA	-	SIM IO pin	Input	Low	-0.30 (3V SIM) -0.30 (1.8V SIM)	-	0.70 (3V SIM) 0.63 (1.8V SIM)
					High	1.85 (3V SIM) 1.17 (1.8V SIM)	2.85 (3V SIM) 1.80 (1.8V SIM)	3.15 (3V SIM) 2.10 (1.8V SIM)
				Output	Low	0	-	0.45
					High	2.40 (3V SIM) 1.35 (1.8V SIM)	-	2.85 (3V SIM) 1.90 (1.8V SIM)

Table 3-1: Connector pin assignments¹ (Continued)

Pin	Signal name	Pin type ²	Description	Direction to module	Active state	Voltage levels (V)		
						Min	Typ	Max
11	VCC_MSM18_DIG ³	-	1.8V reference voltage output	Output	Power	1.75	1.80	1.85
12	USIM_CLK	-	SIM Clock	Output	Low	0	-	0.45
					High	2.40 (3V SIM) 1.35 (1.8V SIM)	-	2.85 (3V SIM) 1.90 (1.8V SIM)
13	NC	-	No connect	-	-	-	-	-
14	USIM_RST	-	SIM Reset	Output	Low	0	-	0.45
					High	2.40 (3V SIM) 1.35 (1.8V SIM)	-	2.85 (3V SIM) 1.90 (1.8V SIM)
15	GND	V	Ground	Input	Power	-	0	-
16	NC	-	No connect	-	-	-	-	-
17	NC	-	No connect	-	-	-	-	-
18	GND	V	Ground	Input	Power	-	0	-
19	NC	-	No connect	-	-	-	-	-
20	W_DISABLE_N	-	Wireless Disable (main RF radio)	Input	Low	-	-	0.7
21	GND	V	Ground	Input	Power	-	0	-
22	NC	-	No connect	-	-	-	-	-
23	NC	-	No connect	-	-	-	-	-
24	VCC	V	Power supply	Input	Power	3.00	3.30	3.60
25	NC	-	No connect	-	-	-	-	-
26	GND	V	Ground	Input	Power	-	0	-
27	GND	V	Ground	Input	Power	-	0	-
28	NC	-	No connect	-	-	-	-	-
29	GND	V	Ground	Input	Power	-	0	-
30	I2C_CLK ^{4,5}	-	I2C serial bus clock	Input High		1.17	1.80	2.10
				Input Low		-0.30		0.63
				Output High		1.35	1.80	1.90
				Output Low		0.00		0.45
31	NC	-	No connect	-	-	-	-	-

Table 3-1: Connector pin assignments¹ (Continued)

Pin	Signal name	Pin type ²	Description	Direction to module	Active state	Voltage levels (V)		
						Min	Typ	Max
32	I2C_DATA ^{4,5}	-	I2C serial bus data	Input High		1.17	1.80	2.10
				Input Low		-0.3		0.63
				Output High		1.35	1.80	1.90
				Output Low		0.00		0.45
33	SYSTEM_RESET_N	-	Reset	Input	Low	-0.30	-	0.63
34	GND	V	Ground	Input	Power	-	0	-
35	GND	V	Ground	Input	Power	-	0	-
36	USB_D-	-	USB data negative	Input/Output	Differential	-	-	-
37	GND	V	Ground	Input	Power	-	0	-
38	USB_D+	-	USB data positive	Input/Output	Differential	-	-	-
39	VCC	V	Power supply	Input	Power	3.00	3.30	3.60
40	GND	V	Ground	Input	Power	-	0	-
41	VCC	V	Power supply	Input	Power	3.00	3.30	3.60
42	WAN_LED_N	OC	LED Driver	Output	Low	0	-	0.15
43	GND	V	Ground	Input	Power	-	0	-
44	ANT_CTRL2 / GPIO3	-	(ANT_CTRL2) Customer-defined external switch control for multiple antennas	Output	High	1.35	-	1.90
				Output	Low	0	-	0.45
				Input High		1.17	1.80	2.10
					Input Low		-0.30	
			(GPIO3) General purpose I/O	Output High		1.35	1.80	1.90
				Output Low		0.00		0.45
				Input High		1.17	1.80	2.10
					Input Low		-0.30	
45	PCM_CLK / I2S_CLK ⁶	-	(PCM_CLK) PCM Clock— Input in Slave mode, output in Master mode	Input High		1.17	1.80	2.10
				Input Low		-0.30		0.63
				Output High		1.35	1.80	1.90
				Output Low		0.00		0.45
			(I2S_CLK) I2S Clock	Output	High	1.35	-	1.90
				Output	Low	0	-	0.45
				Input High		1.17	1.80	2.10
					Input Low		-0.30	

Table 3-1: Connector pin assignments¹ (Continued)

Pin	Signal name	Pin type ²	Description	Direction to module	Active state	Voltage levels (V)		
						Min	Typ	Max
46	DPR/ GPIO4	-	(DPR) Dynamic power control	Input	High	1.17	1.80	2.10
				Input	Low	-0.30	-	0.63
			(GPIO4) General purpose I/O	Input High		1.17	1.80	2.10
				Input Low		-0.30		0.63
				Output High		1.35	1.80	1.90
Output Low		0.00		0.45				
47	PCM_DOUT/ I2S_DOUT ⁶	-	PCM Data Out/ I ² S Data Out	Output	High	1.35	1.80	1.90
				Output	Low	0		0.45
48	NC	-	No connect	-	-	-	-	-
49	PCM_DIN/ I2S_DIN ⁶	-	PCM Data In/ I ² S Data In	Input	High	1.17	1.80	2.10
				Input	Low	-0.30		0.63
50	GND	V	Ground	Input	Power	-	0	-
51	PCM_WS / I2S_SYNC ⁶	-	PCM Sync— Input in Slave mode, output in Master mode	Input High		1.17	1.80	2.10
				Input Low		-0.30		0.63
				Output High		1.35	1.80	1.90
				Output Low		0.00		0.45
			I ² S WS	Output	High	1.35	-	1.90
				Output	Low	0	-	0.45
52	VCC	V	Power supply	Input	Power	3.00	3.30	3.60

1. The host should leave all 'NC' ('no connect) pins unconnected.
2. A—Analog; I—Input; NP—No pull; O—Digital output; OC—Open Collector; PU—Digital input (internal pull up); PD—Digital output (internal pull down); V—Power or ground
3. To avoid adverse effects on module operation, do not draw more than 10 mA current on pin 11.
4. Leave both I2C pins as No Connect if I2C interface is not used.
5. Clock speed: 400 kHz
6. PCM Master/Slave mode and I2S Master mode are supported.

Power supply

The host provides power to the MC7354 through multiple power and ground pins as summarized in [Table 3-2](#).

The host must provide safe and continuous power at all times; the module does not have an independent power supply, or protection circuits to guard against electrical issues.

Table 3-2: Power and ground specifications

Name	Pins	Specification	Min	Typ	Max	Units
VCC	2, 24, 39, 41, 52	Voltage range	See Table 3-1 on page 28 .			
		Ripple voltage	-	-	100	mV _{pp}
GND	4, 9, 15, 18, 21, 26, 27, 29, 34, 35, 37, 40, 43, 50	-	-	0	-	V

USB interface

Note: Host support for USB signals is required.

The USB interface is the path for communication between the host and module.

The interface complies with the [11] *Universal Serial Bus Specification, Rev 2.0*, and the host device must be designed to the same standard. (When designing the host device, careful PCB layout practices must be followed.)

Table 3-3: USB interface

Name	Pin	Description
USB_D-	36	USB data negative
USB_D+	38	USB data positive

USB interface features include:

- Data rate: Full-speed (12 Mbps)/High-speed (480 Mbps)
- Module enumeration:
 - Windows: Modem or COM ports, using host Windows drivers
 - Linux: /dev/ttyUSBn devices for Linux systems with the Sierra Wireless driver installed
- USB-compliant transceivers
- Selective suspend mode
- Resumption initiated by host or module

USB high/full speed throughput performance

This device has been designed to achieve optimal performance and maximum throughput using USB high speed mode. Although the device may operate with a full speed host, throughput performance will be on an “as is” basis and needs to be characterized by the [OEM](#). Note that throughput will be reduced and may vary significantly based on [packet](#) size, host interface, and [firmware](#) revision. Sierra Wireless does not recommend using this device in USB full speed mode.

User-developed drivers

If you will be developing your own USB drivers, see [\[4\] AirCard/AirPrime USB Driver Developer’s Guide \(Doc# 2130634\)](#).

SIM interface

Note: Host support for SIM interface signals is required.

The module supports one SIM (Subscriber Identity Module) (1.8 V or 3 V). The SIM holds account information, allowing users to use their account on multiple devices.

The [SIM](#) pins ([Table 3-4](#)) provide the connections necessary to interface to a SIM socket located on the host device as shown in [Figure 3-3 on page 34](#). Voltage levels over this interface comply with 3GPP standards.

Table 3-4: SIM interface signal

Name	Pin	Description	SIM contact number ¹	Notes
USIM_PWR	8	SIM voltage	1	Power supply for SIM
USIM_DATA	10	Data I/O	7	Bi-directional SIM data line
USIM_CLK	12	Serial clock	3	Serial clock for SIM data
USIM_RST	14	Reset	2	Active low SIM reset
USIM_GND		Ground	5	Ground reference USIM_GND is common to module ground

1. See [Figure 3-4 on page 34](#) for SIM card contacts.

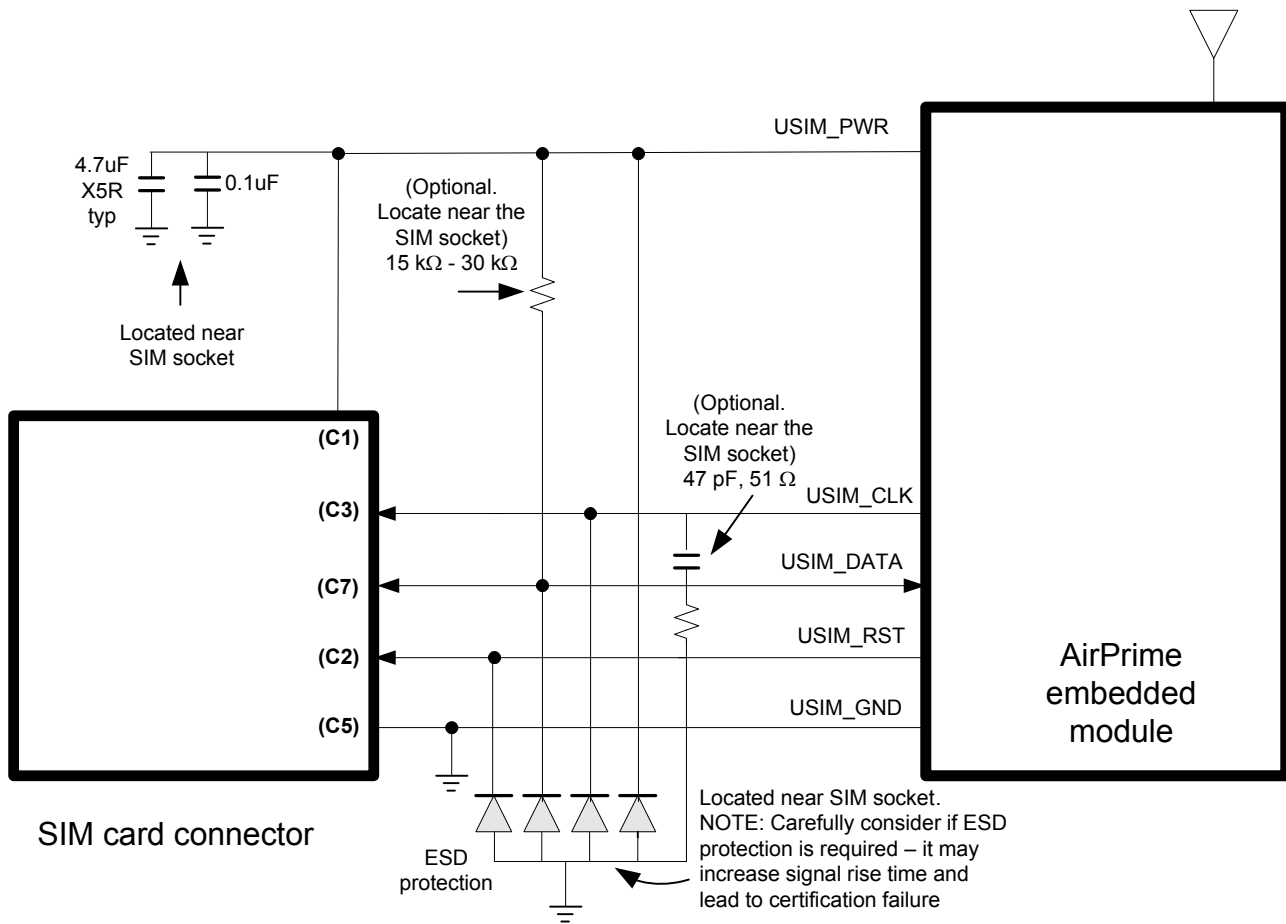

Figure 3-3: SIM application interface

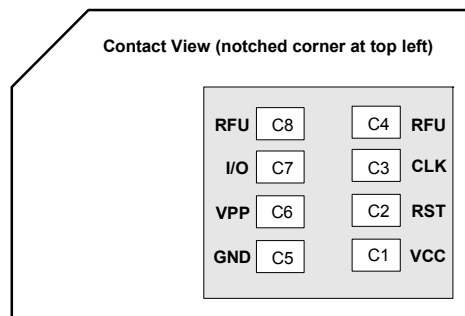

Figure 3-4: SIM card contacts (contact view)

SIM implementation

Note: For interface design requirements, refer to: (2G) 3GPP TS 51.010-1, section 27.17, or (3G) ETSI TS 102 230 V5.5.0, section 5.2.

When designing the remote SIM interface, you *must* make sure that SIM signal integrity is not compromised.

Some design recommendations include:

- Total impedance of the VCC and GND connections to the SIM, measured at the module connector, should be less than $1\ \Omega$ to minimize voltage drop (includes any trace impedance and lumped element components—inductors, filters, etc.).
- Position the SIM connector ≤ 10 cm from the module. If a longer distance is required because of the host device design, use a shielded wire assembly—connect one end as close as possible to the SIM connector and the other end as close as possible to the module connector. The shielded assembly may help shield the SIM interface from system noise.
- Reduce crosstalk on the USIM_DATA line to reduce the risk of failures during GCF approval testing.
- Avoid routing the USIM_CLK and USIM_DATA lines in parallel over distances > 2 cm—cross-coupling of these lines can cause failures.
- 3GPP has stringent requirements for I/O rise time ($< 1\ \mu\text{s}$), signal level limits, and noise immunity—consider this carefully when developing your PCB layout.
 - Keep signal rise time $< 1\ \mu\text{s}$ —keep USIM signals as short as possible, and keep very low capacitance traces on the USIM_DATA and USIM_CLK signals. High capacitance increases signal rise time, potentially causing your device to fail certification tests.
- Add external pull-up resistors ($15\ \text{k}\Omega$ – $30\ \text{k}\Omega$), if required, between the USIM_DATA and USIM_PWR lines to optimize the signal rise time.
- VCC line should be decoupled close to the SIM socket.
- SIM is specified to run up to 5 MHz (SIM clock rate). Take note of this speed in the placement and routing of the SIM signals and connectors.
- You must decide whether additional ESD protection is required for your product, as it is dependent on the application, mechanical enclosure, and SIM connector design. The SIM pins will require additional ESD protection if they are exposed to high ESD levels (i.e. can be touched by a user).
- Putting an optional decoupling capacitor at USIM_PWR near the SIM socket is recommended—the longer the trace length (impedance) from the socket to the module, the greater the capacitance requirement to meet compliance tests.
- Putting an optional series capacitor and resistor termination (to ground) at USIM_CLK at the SIM socket to reduce EMI and increase signal integrity is recommended if the trace length between the SIM socket and module is long— $47\ \text{pF}$ and $50\ \Omega$ resistor are recommended.
- Test your first prototype host hardware with a Comprion IT³ SIM test device at a suitable testing facility.

Control interface (Signals)

The MC7354 provides signals for:

- Waking the host when specific events occur
- Host control of the module's radios
- LED driver output

These signals are summarized in [Table 3-5](#) and paragraphs that follow.

Table 3-5: Module control signals

Name	Pin	Description	Type ¹
WAKE_N	1	Wake host	OC
W_DISABLE_N	20	Wireless disable (Main RF)	PU
WAN_LED_N	42	LED driver	OC

1. OC—Open Collector; PU—Digital pin Input, internal pull up

WAKE_N — Wake host

Note: Host support for WAKE_N is optional.

The module uses WAKE_N to wake the host when specific events occur. (Support for this signal is firmware-dependent. Contact your Sierra Wireless account representative to determine specific availability.)

The host must provide a 5 kΩ–100 kΩ pullup resistor that considers total line capacitance (including parasitic capacitance) such that when WAKE_N is deasserted, the line will rise to 3.3 V (Host power rail) in < 100 ns.

See [Figure 3-5 on page 36](#) for a recommended implementation.

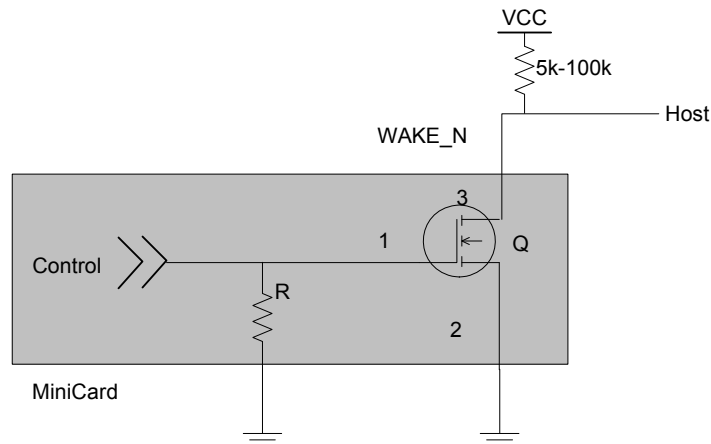

Figure 3-5: Recommended WAKE_N connection

W_DISABLE_N — Wireless disable

Note: Host support for wireless disable signals is optional.

The host device uses W_DISABLE_N (pin 20) to enable/disable the WWAN or radio modem. When disabled, the modem cannot transmit or receive information.

Letting this signal float high allows the module to operate normally. This switch follows the behavior described in [10] *PCI Express Mini Card Electromechanical Specification Revision 1.2*. This pin has a 20 k Ω pull-up resistor. See [Figure 3-6 on page 37](#) for a recommended implementation.

When integrating with your host device, keep the following in mind:

- The signal is an input to the module and should be driven LOW only for its active state (controlling the power state); otherwise it should be floating or (High impedance). It should never be driven to a logic high level. The module has an internal pull-up resistor to Module Power (3.3V) in place, so if the signal is floating or (high impedance), then the radio is on.
- Wait for two seconds after asserting W_DISABLE_N before disconnecting power.
- If the host never needs to assert this power state control to the module, leave this signal unconnected from the host interface.

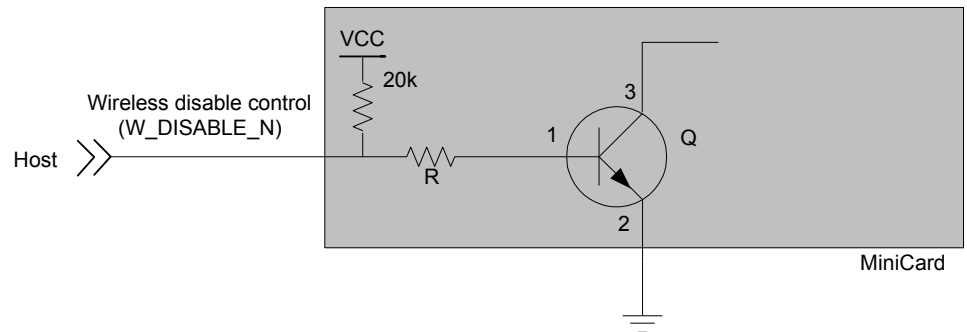

Figure 3-6: Recommended wireless disable connection

WAN_LED_N—LED output

Note: Host support for WAN_LED_N is optional.

The module drives the LED output according to [10] *PCI Express Mini Card Electromechanical Specification Revision 1.2*.

Note: The LED configuration is customizable. Contact your Sierra Wireless account representative for details.

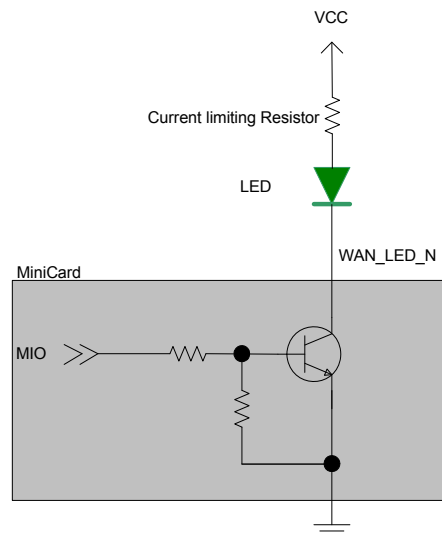

Figure 3-7: Example LED

SYSTEM_RESET_N—Reset Input

Note: Host support for SYSTEM_RESET_N is optional.

SYSTEM_RESET_N has an internal 1.8 V internal pull up. Set this signal to active low to reset the device. Note that the minimum pulse width is 250 ms.

PCM/I2S Audio Interface

Note: PCM Master/Slave mode, Auxiliary PCM mode, and I2S Master modes are supported; I2S Slave mode is not supported. The default setting is PCM slave mode.

The module implements a PCM/I2S digital audio interface using a dedicated serial link for digital audio data; all other signals, such as subcoding and control, are transmitted separately. The audio interface could be switchable via AT command between PCM and I2S. The PCM/I2S signals are summarized in the following table.

Table 3-6: PCM/I2S Interface signals

Signal name	Pin	Description
PCM_CLK/I2S_CLK	45	PCM Clock/I2S Clock
PCM_DOUT/I2S_DOUT	47	PCM Data Out/I2S Data Out
PCM_DIN/I2S_DIN	49	PCM Data In/I2S Data In
PCM_SYNC/I2S_WS	51	PCM SYNC/I2S WS

PCM

The PCM interface implementation details include:

- Modes: Master and slave
- Sampling rates: 8 kHz, 16 kHz
- Audio compression formats: Linear, μ -law, A-Law
- Padding: Disabled, enabled
- Bits per frame: 8, 16, 32, 64, 128, 256
- Bit frequency: (Sampling rate * Bits per frame)

Figure 3-8, Figure 3-9 and Figure 3-10, and Table 3-7 below describe the PCM interface timing.

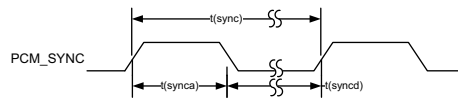

Figure 3-8: PCM_SYNC timing

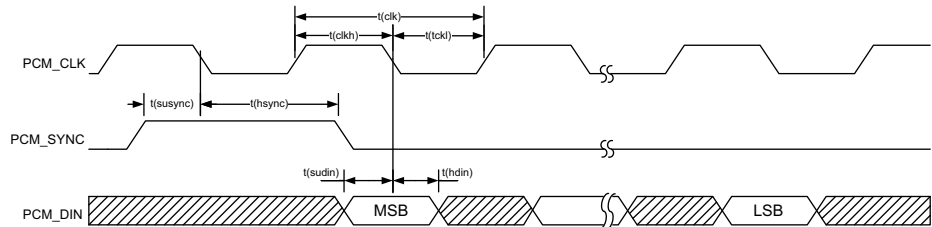

Figure 3-9: Timing—PCM_CODEEC to Module

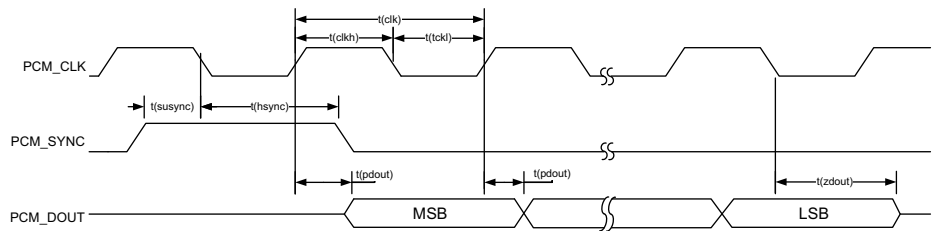

Figure 3-10: Timing—Module to PCM_CODEEC

Table 3-7: PCM Timing¹

Parameter	Description	Min	Typ	Max	Unit
T(sync)	PCM_FS cycle time	-	125	-	μ s
T(synch)	PCM_FS high time	-	488	-	ns
T(syncl)	PCM_FS low time	-	124.5	-	μ s
T(clk)	PCM_CLK cycle time	-	488	-	ns
T(clkh)	PCM_CLK high time	-	244	-	ns
T(clkl)	PCM_CLK low time	-	244	-	ns

Table 3-7: PCM Timing¹ (Continued)

Parameter	Description	Min	Typ	Max	Unit
T(sync_offset)	PCM_SYNC offset time to PCM_CLK falling	-	122	-	ns
T(sudin)	PCM_DIN setup time before falling edge of PCM_CLK	60	-	-	ns
T(hdin)	PCM_DIN hold time after falling edge of PCM_CLK	60	-	-	ns
T(pdout)	Delay from PCM_CLK rising to PCM_DOUT valid	-	-	60	ns
T(zdout)	Delay from PCM_CLK falling to PCM_DOUT HIGH-Z	-	-	60	ns

1. Maximum PCM clock rate is 2.048 MHz.

I2S

The I2S can be used to transfer serial digital audio to/from an external stereo DAC/ADC. Interface implementation details include:

- Modes: Master (Slave mode is not supported)
- Sampling rates: 48 kHz
- Bits per frame: 16
- Bit clock: 1536 kHz

Figure 3-11 and Table 3-8 describe the I2S interface timing (per the Philips I2S bus timing specification).

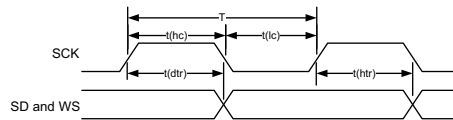

Figure 3-11: I2S transmitter timing

Table 3-8: I2S master transmitter timing^{1,2}

Parameter	Description	Condition	Min	Typ	Max	Unit
T	Clock period	I2S requirement: min T=293	293	326	359	ns
t(hc)	Clock high	I2S requirement: min > 0.35T	120	-	-	ns
t(lc)	Clock low	I2S requirement: min > 0.35T	120	-	-	ns
t(dtr)	Delay	I2S requirement: Max < 0.8T	-	-	250	ns
t(htr)	Hold time	I2S requirement: min > 0	1--	-	-	ns

1. Bit clock: 1536 KHz (±10%)

2. Sample rate: 48 KHz (16 bits per sample)

Antenna control

Note: Host support for antenna control signals is optional.

The MC7354 Mini Card provides three output signals that may be used for host designs that incorporate tunable antennas. For details, see [2] *AirPrime MiniCard MC73xx/MC8805 AT Command Reference (Doc# 4114486)*.

Table 3-9: Antenna control signals

Name	Pin	Description
ANT_CTRL0	3	Customer-defined external switch control for tunable antennas
ANT_CTRL1	5	
ANT_CTRL2	44	

4: RF Specifications

The MC7354 includes three RF connectors for use with host-supplied antennas:

- Main RF connector—Rx/Tx path
- GNSS connector 1—Dedicated GNSS
- Diversity/MIMO/GNSS connector 2—Diversity, MIMO, or GNSS

The module does not have integrated antennas.

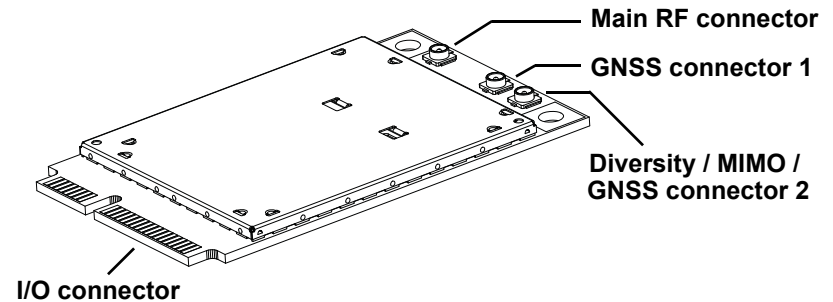

Figure 4-1: Module connectors

RF connections

When attaching antennas to the module:

- Use Hirose U.FL connectors (3 mm x 3 mm, low profile; model U.FL #CL331-0471-0-10) to attach antennas to connection points on the module, as shown in [Figure 4-1](#) on page 43.
- Match coaxial connections between the module and the antenna to 50 Ω .
- Minimize RF cable losses to the antenna; the recommended maximum cable loss for antenna cabling is 0.5 dB.
- To ensure best thermal performance, mounting holes must be used to attach (ground) the device to the main PCB ground or a metal chassis.

*Note: To **disconnect** the antenna, make sure you use the Hirose U.FL connector removal tool (P/N UFL-LP-N-2(01)) to prevent damage to the module or coaxial cable assembly.*

Note: If the antenna connection is shorted or open, the modem will not sustain permanent damage.

Shielding

The module is fully shielded to protect against EMI and must not be removed.

Antenna and cabling

When selecting the antenna and cable, it is critical to RF performance to optimize antenna gain and cable loss.

Note: For detailed electrical performance criteria, see [Appendix A: Antenna Specification](#) on page 75.

Choosing the correct antenna and cabling

When matching antennas and cabling:

- The antenna (and associated circuitry) should have a nominal impedance of 50 Ω with a recommended return loss of better than 10 dB across each frequency band of operation.
- The system gain value affects both radiated power *and* regulatory (FCC, IC, CE, etc.) test results.

Designing custom antennas

Consider the following points when designing custom antennas:

- A skilled RF engineer should do the development to ensure that the RF performance is maintained.
- If both CDMA and UMTS modules will be installed in the same platform, you may want to develop separate antennas for maximum performance.

Determining the antenna's location

When deciding where to put the antennas:

- Antenna location may affect RF performance. Although the module is shielded to prevent interference in most applications, the placement of the antenna is still very important—if the host device is insufficiently shielded, high levels of broadband noise or spurious interference can degrade the module's performance.
- Connecting cables between the module and the antenna must have 50 Ω impedance. If the impedance of the module is mismatched, RF performance is reduced significantly.
- Antenna cables should be routed, if possible, away from noise sources (switching power supplies, LCD assemblies, etc.). If the cables are near the noise sources, the noise may be coupled into the RF cable and into the antenna. See [Interference from other wireless devices on page 45](#).

Disabling the diversity antenna

- For LTE/UMTS bands, use the AT command **!RXDEN=0** to disable receive diversity or **!RXDEN=1** to enable receive diversity.
- For CDMA bands, use the AT command **IDIVERSITY** to enable or disable receive diversity.

Note: A diversity antenna is used to improve connection quality and reliability through redundancy. Because two antennas may experience difference interference effects (signal distortion, delay, etc.), when one antenna receives a degraded signal, the other may not be similarly affected.

Ground connection

When connecting the module to system ground:

- Prevent noise leakage by establishing a very good ground connection to the module through the host connector.
- Connect to system ground using the two mounting holes at the top of the module (shown in [Figure 4-1](#) on page 43).
- Minimize ground noise leakage into the RF.
Depending on the host board design, noise could *potentially* be coupled to the module from the host board. This is mainly an issue for host designs that have signals traveling along the length of the module, or circuitry operating at both ends of the module interconnects.

Interference and sensitivity

Several interference sources can affect the module's RF performance (RF desense). Common sources include power supply noise and device-generated RF.

RF desense can be addressed through a combination of mitigation techniques ([Methods to mitigate decreased Rx performance on page 46](#)) and radiated sensitivity measurement ([Radiated sensitivity measurement on page 47](#)).

Note: The MC7354 is based on ZIF (Zero Intermediate Frequency) technologies. When performing EMC (Electromagnetic Compatibility) tests, there are no IF (Intermediate Frequency) components from the module to consider.

Interference from other wireless devices

Wireless devices operating inside the host device can cause interference that affects the module.

To determine the most suitable locations for antennas on your host device, evaluate each wireless device's radio system, considering the following:

- Any harmonics, sub-harmonics, or cross-products of signals generated by wireless devices that fall in the module's Rx range may cause spurious response, resulting in decreased Rx performance.
- The Tx power and corresponding broadband noise of other wireless devices may overload or increase the noise floor of the module's receiver, resulting in Rx desense.

The severity of this interference depends on the closeness of the other antennas to the module's antenna. To determine suitable locations for each wireless device's antenna, thoroughly evaluate your host device's design.

Host-generated RF interference

All electronic computing devices generate RF interference that can negatively affect the receive sensitivity of the module.

Proximity of host electronics to the antenna in wireless devices can contribute to decreased Rx performance. Components that are most likely to cause this include:

- Microprocessor and memory
- Display panel and display drivers
- Switching-mode power supplies

Device-generated RF interference

The module can cause interference with other devices. Wireless devices such as AirPrime embedded modules transmit in bursts (pulse transients) for set durations (RF burst frequencies). Hearing aids and speakers convert these burst frequencies into audible frequencies, resulting in audible noise.

Methods to mitigate decreased Rx performance

It is important to investigate sources of localized interference early in the design cycle. To reduce the effect of device-generated RF on Rx performance:

- Put the antenna as far as possible from sources of interference.
- Shield the host device. The module itself is well shielded to avoid external interference. In most instances, it is necessary to employ shielding on the components of the host device (such as the main processor and parallel bus) that have the highest RF emissions.
- Filter out unwanted high-order harmonic energy by using discrete filtering on low frequency lines.
- Form shielding layers around high-speed clock traces by using multi-layer PCBs.
- Route antenna cables away from noise sources.

Radiated Spurious Emissions (RSE)

When designing an antenna for use with AirPrime embedded modules, the host device with an AirPrime embedded module must satisfy the radiated spurious emission (RSE) test cases described in:

- (CDMA) Refer to CDMA standards for receive-only mode, and local regulatory bodies for transmit mode (transmitter is operating).

Note that antenna impedance affects radiated emissions, which must be compared against the conducted 50-ohm emissions baseline. (AirPrime embedded modules meet the 50-ohm conducted emissions requirement.)

Radiated sensitivity measurement

A wireless host device contains many noise sources that contribute to a reduction in Rx performance.

To determine the extent of any receiver performance desensitization due to self-generated noise in the host device, over-the-air (OTA) or radiated testing is required. This testing can be performed by Sierra Wireless or you can use your own OTA test chamber for in-house testing.

Sierra Wireless' sensitivity testing and desensitization investigation

Although AirPrime embedded modules are designed to meet network operator requirements for receiver performance, they are still susceptible to various performance inhibitors.

As part of the Engineering Services package, Sierra Wireless offers modem OTA sensitivity testing and desensitization (desense) investigation. For more information, contact your account manager or the Sales Desk (see [Contact Information on page 4](#)).

Note: Sierra Wireless has the capability to measure TIS (Total Isotropic Sensitivity) and TRP (Total Radiated Power) according to CTIA's published test procedure.

Sensitivity vs. frequency

For CDMA bands, sensitivity is defined as the input power level in dBm that produces a FER (Frame Error Rate) of 0.5%. Sensitivity should be measured at all CDMA frequencies across each band.

For UMTS bands, sensitivity is defined as the input power level in dBm that produces a BER (Bit Error Rate) of 2% (GSM) or 0.1% (UMTS). Sensitivity should be measured at all GSM / UMTS frequencies across each band.

For LTE bands, sensitivity is defined as the RF level at which throughput is 95% of maximum.

Supported frequencies

The MC7354 supports:

- Six-band LTE—See [Table 4-1 on page 48](#).
- Penta-band WCDMA/HSDPA/HSUPA/HSPA+/DC-HSPA+—See [Table 4-3 on page 48](#).
- Penta-band WCDMA receive diversity
- Tri-band CDMA—See [Table 4-5 on page 49](#).
- Quad-band GSM/GPRS/EDGE—See [Table 4-4 on page 49](#).
- GPS and GLONASS—See [Table 4-11 on page 52](#).

- Inter-RAT and inter-frequency cell reselection and handover between supported frequency bands

Table 4-1: LTE frequency band support

Band	Frequencies
Band 2	Tx: 1850–1910 MHz Rx: 1930–1990 MHz
Band 4 (AWS)	Tx: 1710–1755 MHz Rx: 2110–2155 MHz
Band 5	Tx: 824–849 MHz Rx: 869–894 MHz
Band 13	Tx: 777–787 MHz Rx: 746–756 MHz
Band 17	Tx: 704–716 MHz Rx: 734–746 MHz
Band 25	Tx: 1850–1915 MHz Rx: 1930–1995 MHz

Table 4-2: LTE bandwidth support¹

Band	1.4 MHz	3 MHz	5 MHz	10 MHz	15 MHz	20 MHz
Band 2	✗	✗	✓	✓	✓ ²	✓ ²
Band 4 (AWS)	✗	✗	✓	✓	✓	✓
Band 5	✗	✗	✓	✓ ²	✗	✗
Band 13	✗	✗	✓ ²	✓ ²	✗	✗
Band 17	✗	✗	✓ ²	✓ ²	✗	✗
Band 25	✗	✗	✓	✓	✓ ²	✓ ²

1. Table contents are derived from 3GPP TS 36.521-1 v9.4.1, table 5.4.2.1-1.
2. Bandwidth for which a relaxation of the specified UE receiver sensitivity requirement (Clause 7.3 of 3GPP TS 36.521-1 v9.4.1) is allowed.

Table 4-3: WCDMA frequency band support¹

Band	Frequencies
Band 1 WCDMA 2100	Tx: 1920–1980 MHz Rx: 2110–2170 MHz
Band 2 WCDMA 1900	Tx: 1850–1910 MHz Rx: 1930–1990 MHz
Band 4 AWS 1700/2100	Tx: 1710–1755 MHz Rx: 2110–2155 MHz

Table 4-3: WCDMA frequency band support¹

Band	Frequencies
Band 5 WCDMA 850	Tx: 824–849 MHz Rx: 869–894 MHz
Band 8 WCDMA 900	Tx: 880–915 MHz Rx: 925–960 MHz

1. WCDMA channel spacing is 5 MHz, but this can be adjusted to optimize performance in a particular deployment scenario.

Table 4-4: GSM frequency band support

Band	Frequencies
GSM 850	Tx: 824–849 MHz Rx: 869–894 MHz
EGSM 900	Tx: 880–915 MHz Rx: 925–960 MHz
DCS 1800	Tx: 1710–1785 MHz Rx: 1805–1880 MHz
PCS 1900	Tx: 1850–1910 MHz Rx: 1930–1990 MHz

Table 4-5: CDMA frequency band support

Band	Frequencies
Band Class 0 (Cellular 800 MHz)	Tx: 824–849 MHz Rx: 869–894 MHz
Band Class 1 (PCS)	Tx: 1850–1910 MHz Rx: 1930–1990 MHz
Band Class 10 (Secondary 800 MHz) ¹	Tx: 817–824 MHz Rx: 861–869 MHz

1. BC10 subclasses 2 and 3 (system designator C and D) are supported

Conducted Rx sensitivity / Tx power

Table 4-6: Conducted Rx (Receive) sensitivity — LTE bands

LTE bands		Conducted Rx sensitivity (dBm)			
		Primary (Typical)	Secondary (Typical)	SIMO (Typical)	SIMO ¹ (Worst case)
LTE Band 2	Full RB BW: 10 MHz ²	-99.1	-98.2	-101.6	-94.3
LTE Band 4		-99.7	-98.9	-102.4	-96.3
LTE Band 5		-98.0	-99.1	-101.5	-94.3
LTE Band 13		-98.7	-99.1	-101.9	-96.3 ³
LTE Band 17		-99.7	-99.0	-101.1	-93.3
LTE Band 25		-98.8	-98.1	-101.4	-92.8

1. Per 3GPP specification (unless otherwise indicated)
2. Sensitivity values scale with bandwidth:
 $x_MHz_Sensitivity = 10_MHz_Sensitivity - 10 * \log(10 \text{ MHz} / x_MHz)$
 Note: Bandwidth support is dependent on firmware version.
3. Per Verizon specification (3GPP specification is -93.3 dBm.)

Table 4-7: Conducted Rx (Receive) sensitivity — CDMA bands

CDMA bands		Conducted Rx sensitivity (dBm)	
		Typical	Worst case ¹
BC0 (Cellular 800 MHz)	CDMA 1x 0.5% FER	-109.6	-104.0
	EVDO rev A 0.5% PER	-109.8	-105.5
BC1 (PCS 1900 MHz)	CDMA 1x 0.5% FER	-110.8	-104.0
	EVDO rev A 0.5% PER	-110.6	-105.5
BC10 (Secondary 800 MHz)	CDMA 1x 0.5% FER	-110.3	-104.0
	EVDO rev A 0.5% PER	-110.7	-105.5

1. Per 3GPP2 specification.

Table 4-8: Conducted Rx (Receive) sensitivity — UMTS bands

UMTS bands		Conducted Rx sensitivity (dBm)		
		Primary (Typical)	Secondary (Typical)	Primary/Secondary (Worst case) ¹
Band 1 (UMTS 2100)	0.1% BER 12.2 kbps	-111.0	-110.4	-106.7
Band 2 (UMTS 1900)		-111.4	-110.5	-104.7
Band 4 (AWS 1700/2100)		-112.1	-110.6	-106.7
Band 5 (UMTS 850)		-110.8	-111.7	-104.7
Band 8 (UMTS 900)		-111.8	-111.5	-103.7

1. Per 3GPP specification.

Table 4-9: Conducted Rx (Receive) sensitivity — GSM/EDGE bands

GSM/EDGE bands			Conducted Rx sensitivity (dBm)	
			Typical	Worst case ¹
GSM 850	2% BER	CS ²	-109	-102
	10% BLER	GMSK (CS1)	-111	-104
		EDGE (MCS5)	-102	-98
EGSM 900	2% BER	CS ²	-109	-102
	10% BLER	GMSK (CS1)	-111	-104
		EDGE (MCS5)	-102	-98
DCS 1800	2% BER	CS ²	-108	-102
	10% BLER	GMSK (CS1)	-111	-104
		EDGE (MCS5)	-101	-98
PCS 1900	2% BER	CS ²	-108	-102
	10% BLER	GMSK (CS1)	-111	-104
		EDGE (MCS5)	-101	-98

1. Per 3GPP specification.

2. CS=Circuit Switched

Table 4-10: Conducted Tx (Transmit) power tolerances

Parameter	Conducted transmit power	Notes
LTE		
LTE Band 2, 4, 5, 13, 17, 25	+23 dBm ± 1 dB	

Table 4-10: Conducted Tx (Transmit) power tolerances (Continued)

Parameter	Conducted transmit power	Notes
UMTS		
Band 1 (IMT 2100 12.2 kbps) Band 2 (UMTS 1900 12.2 kbps) Band 4 (AWS 1700/2100 12.2 kbps) Band 5 (UMTS 850 12.2 kbps) Band 8 (UMTS 900 12.2 kbps)	+23 dBm ± 1 dB	Connectorized (Class 3)
GSM / EDGE		
GSM850 CS EGSM900 CS	+32 dBm ± 1 dB	GMSK mode, connectorized (Class 4; 2 W, 33 dBm)
	+27 dBm ± 1 dB	8PSK mode, connectorized (Class E2; 0.5 W, 27 dBm)
DCS1800 CS PCS1900 CS	+29 dBm ± 1 dB	GMSK mode, connectorized (Class 1; 1 W, 30 dBm)
	+26 dBm ± 1 dB	8PSK mode, connectorized (Class E2; 0.4 W, 26 dBm)
CDMA		
Band Class 0 (Cellular)	+24 dBm +0.5/-1 dB	
Band Class 1 (PCS)	+24 dBm +0.5/-1 dB	
Band Class 10 (Cellular)	+24 dBm +0.5/-1 dB	

GNSS specifications

Note: For detailed electrical performance criteria, see [Recommended GNSS antenna specifications on page 77](#).

Table 4-11: GNSS specifications

Parameter/feature	Description
Satellite channels	Maximum 30 channels (16 GPS, 14 GLONASS), simultaneous tracking
Protocols	NMEA 0183 V3.0
Acquisition time	Hot start: 1 s Warm start: 29 s Cold start: 32 s
Accuracy	Horizontal: < 2 m (50%); < 5 m (90%) Altitude: < 4 m (50%); < 8 m (90%) Velocity: < 0.2 m/s

Table 4-11: GNSS specifications (Continued)

Parameter/feature	Description
Sensitivity	Tracking ¹ : -161 dBm Acquisition ² (Assisted, non-LTE): -158 dBm Acquisition (Assisted, LTE): -153 dBm Acquisition (Standalone): -145 dBm
Operational limits	Altitude <6000 m or velocity <100 m/s (Either limit may be exceeded, but not both.)

1. Tracking sensitivity is the lowest GNSS signal level for which the device can still detect an in-view satellite 50% of the time when in sequential tracking mode.
2. Acquisition sensitivity is the lowest GNSS signal level for which the device can still detect an in-view satellite 50% of the time.

Power consumption

Power consumption measurements in the tables below are for the MC7354 Mini Card module connected to the host PC via USB.

The module does not have its own power source and depends on the host device for power. For a description of input voltage requirements, see [Power supply on page 32](#).

Table 5-1: Averaged standby DC power consumption

Signal	Description ¹	Current			Notes / configuration
		Typ	Max ²	Unit	
VCC	Standby current consumption (Sleep mode activated³)				
	LTE	1.8	3.0	mA	DRX cycle = 8 (2.56 s)
	CDMA EVDO	1.9	3.0	mA	QPCH = 5.12 s
	HSDPA / WCDMA	1.8	3.0	mA	DRX cycle = 8 (2.56 s)
	GSM / GPRS / EDGE	2.4	3.5	mA	MFRM = 5 (1.175 s)
	Standby current consumption⁴ (Sleep mode deactivated³)				
	LTE	25	30	mA	DRX cycle = 8 (2.56 s)
	CDMA EVDO	23	28	mA	QPCH = 5.12 s
	HSDPA / WCDMA	23	28	mA	DRX cycle = 8 (2.56 s)
	GSM / GPRS / EDGE	27	32	mA	MFRM = 5 (1.175 s)
	Low Power Mode (LPM)/Offline Mode⁴ (Sleep mode activated³)				
	RF disabled, but module is operational	1.3	1.6	mA	
	Low Power Mode (LPM)/Offline Mode⁴ (Sleep mode deactivated³)				
	RF disabled, but module is operational	23	27	mA	

1. For supported bands, see [Table 4-1, LTE frequency band support](#), on page 48, [Table 4-3, WCDMA frequency band support](#), on page 48, and [Table 4-4, GSM frequency band support](#), on page 49.
2. Measured at 30°C/nominal voltage.
3. Assumes USB bus is fully suspended during measurements
4. LPM and standby power consumption will increase when LEDs are enabled. To reduce power consumption, configure LEDs to remain off while in standby and LPM modes.

Table 5-2: Averaged call mode DC power consumption

Description	Current ¹		Notes
	Max ²	Unit	
1x/EV-DO	160	mA	<ul style="list-style-type: none"> 0 dBm Tx power Data call, any band
	1100	mA	<ul style="list-style-type: none"> Worst case BC1 at 24 dBm Tx power Data call, any band @3.0 V
LTE	300	mA	<ul style="list-style-type: none"> 68/23 Mbps—0 dBm Tx power 10 MHz bandwidth MIMO operation
	600	mA	<ul style="list-style-type: none"> 68/23 Mbps—20 dBm Tx power 10 MHz bandwidth MIMO operation
	950 ³	mA	<ul style="list-style-type: none"> Worst case 68/23 Mbps—23 dBm Tx power All bands 20 MHz bandwidth
WCDMA	200	mA	<ul style="list-style-type: none"> 384 kbps at 0 dBm Tx power
	500	mA	<ul style="list-style-type: none"> 384 kbps at 20 dBm Tx power
	850	mA	<ul style="list-style-type: none"> Worst case 23 dBm Tx power
HSPA	250	mA	<ul style="list-style-type: none"> All speeds at 0 dBm Tx power
	550	mA	<ul style="list-style-type: none"> All speeds at 20 dBm Tx power
	925	mA	<ul style="list-style-type: none"> Worst case 23 dBm Tx power
GSM/GPRS	525	mA	<ul style="list-style-type: none"> All bands 2 timeslots at 32 dBm Tx power
EDGE	550	mA	<ul style="list-style-type: none"> All bands 4 timeslots at 27 dBm Tx power
Peak current (averaged over 100 μ s)	2.5	A	<ul style="list-style-type: none"> All GSM/GPRS/EDGE bands

1. Measured at 30°C/nominal voltage.
 2. Highest current is on LTE Band 2 and CDMA/EVDO BC1.
 3. Worst case current at temperature/voltage extremes is 1.1 A.

Table 5-3: Miscellaneous DC power consumption

Signal	Description	Current / Voltage			Unit	Notes / configuration
		Min	Typ	Max		
VCC	USB active current		10	15	mA	High speed USB connection, $C_L = 50$ pF on D+ and D- signals
	Inrush current		750	2500	mA	<ul style="list-style-type: none"> Assumes power supply turn on time > 100μs Dependent on host power supply rise time.
GNSS Signal connector 1	Active bias on GNSS port	50	75	100	mA	GNSS connector 1 in Figure 4-1 on page 43
	Max. voltage output @ 75mA			3.3	V	

Module power states

The module has four power states, as described in [Table 5-4](#).

Table 5-4: Module power states

State	Details	Host is powered	Module is powered	USB interface active	RF enabled
Normal (Default state)	<ul style="list-style-type: none"> Module is active Default state when VCC is first applied in the absence of W_DISABLE_N control Module is capable of placing/receiving calls, or establishing data connections on the wireless network Current consumption is affected by several factors, including: <ul style="list-style-type: none"> Radio band being used Transmit power Receive gain settings Data rate Number of active Tx time slots 	✓	✓	✓	✓
Low power ('Airplane mode')	<ul style="list-style-type: none"> Module is active Module enters this state: <ul style="list-style-type: none"> Under host interface control using either of the following methods: <ul style="list-style-type: none"> Host issues AT+CFUN=0 ([1] AT Command Set for User Equipment (UE) (Release 6) (Doc# 3GPP TS 27.007)), or Host asserts W_DISABLE_N, after AT!PCOFFEN=0 has been issued. Automatically, when critical temperature or voltage trigger limits have been reached 	✓	✓	✓	✗

Table 5-4: Module power states (Continued)

State	Details	Host is powered	Module is powered	USB interface active	RF enabled
Sleep	<ul style="list-style-type: none"> Normal state of module between calls or data connections Module cycles between wake (polling the network) and sleep, at network provider-determined interval. 	✓	✓	✗	✗
Disconnected	<ul style="list-style-type: none"> Host power source is disconnected from the module and all voltages associated with the module are at 0 V. To safely power off, see Required shutdown sequence on page 60. 	✗	✗	✗	✗

Power state transitions

The module uses state machines to monitor supply voltage and operating temperature, and notifies the host when critical threshold limits are exceeded. (See [Table 5-5](#) for trigger details and [Figure 5-1](#) for state machine behavior.)

Power state transitions may occur:

- Automatically, when critical supply voltage or module temperature trigger levels are encountered.
- Under host control, using available AT commands in response to user choices (for example, opting to switch to airplane mode) or operating conditions.

Table 5-5: Power state transitions (including voltage/temperature trigger levels)

Transition	Voltage		Temperature ¹		Notes
	Trigger	v ²	Trigger	°C	
Normal to Low Power	VOLT_HI_CRIT	3.8	TEMP_LO_CRIT	-45	<ul style="list-style-type: none"> RF activity suspended
	VOLT_LO_CRIT	2.9	TEMP_HI_CRIT	110	
Low Power to Normal	VOLT_HI_NORM	3.5	TEMP_NORM_LO	-40	<ul style="list-style-type: none"> RF activity resumed
Low Power to Normal or Remain in Normal (Remove warnings)	VOLT_LO_NORM	3.05	TEMP_HI_NORM	85	
Normal (Issue warning)	VOLT_LO_WARN	2.95	TEMP_HI_WARN	95	
Power off/on (Host-initiated)	-	-	-	-	<ul style="list-style-type: none"> Power off recommended when supply voltage or module operating temperature is critically low or high. To safely power off, see Required shutdown sequence on page 60.

1. Module-reported temperatures at the printed circuit board.
 2. Supply voltage—3.3V

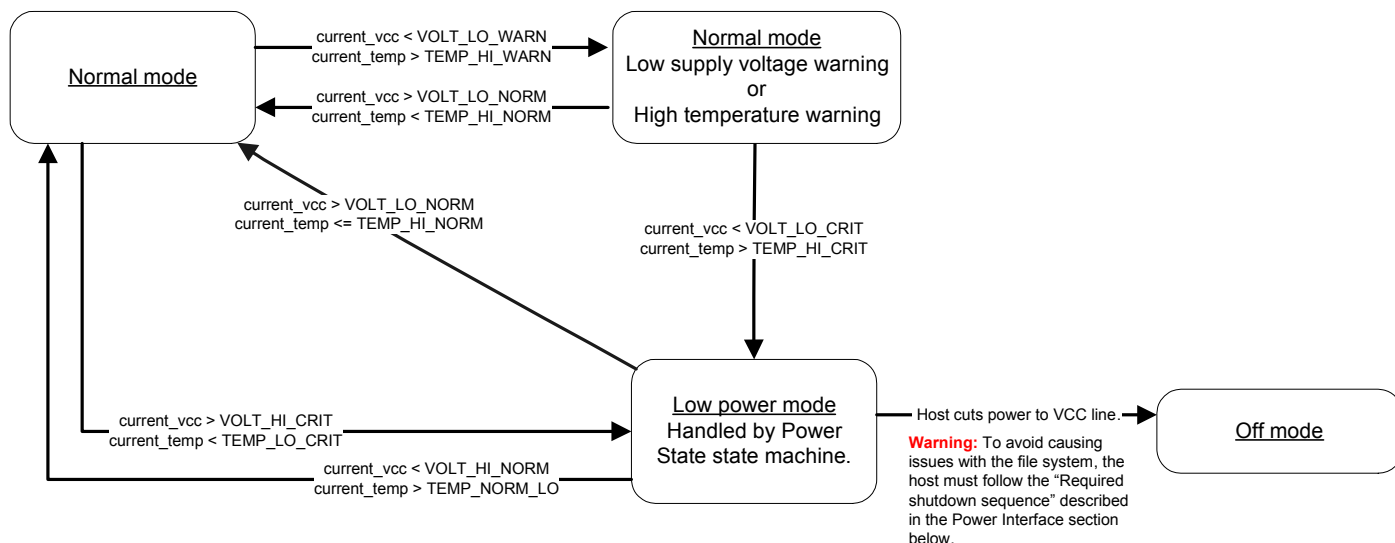

Figure 5-1: Voltage/temperature monitoring state machines

Power interface

Power ramp-up

On initial power up, inrush current depends on the power supply rise time—turn on time >100 μs is required for < 3A inrush current.

The supply voltage must remain within specified tolerances while this is occurring.

Power-on/off timing

Figure 5-2 describes the timing sequence for powering the module on and off.

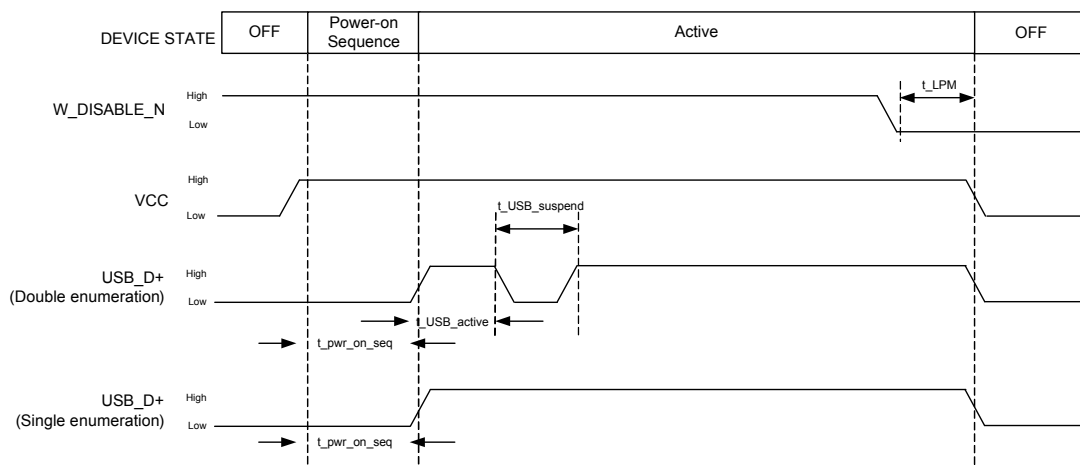

Figure 5-2: Signal timing (Power-on, USB enumeration, and power-off)

Table 5-6: Power-on timing parameters (double enumeration)

Parameter	Typical (s)	Maximum (s)
t_pwr_on_seq	0.43	0.5
t_USB_active	0.25	0.3
t_USB_suspend	12	13

Table 5-7: Power-on timing parameters (single enumeration)

Parameter	Typical (s)	Maximum (s)
t_pwr_on_seq	12	13

Table 5-8: Power-off timing parameters

Parameter	Minimum (s)
t_LPM	13

Required shutdown sequence

Warning: *To avoid causing issues with the file system, follow this shutdown sequence.*

1. Put the module into low power mode (LPM), using either of the following methods:
 - Issue AT+CFUN=0
 - or
 - After issuing AT!PCOFFEN=0, assert W_DISABLE_N
2. Wait at least t_LPM seconds.
3. Remove power.

USB enumeration

The unit supports single and double USB enumeration with the host:

- Single enumeration—Enumeration starts within maximum t_pwr_on_seq seconds of power-on.
- Double enumeration—As shown in [Figure 5-2](#):
 - First enumeration starts within t_pwr_on_seq seconds of power-on (while USB_D+ is high)
 - Second enumeration starts within 14 seconds of power-on (when USB_D+ goes high again)

Transmit power waveform (GSM)

As shown in [Figure 5-3](#), at maximum GSM transmit power, the input current can remain at 2.2 A for up to 25% of each 4.6 ms GSM cycle (1.15 ms) after reaching an initial peak of 2.5 A (average over 100 μ s). For class 12 operation, the peak could remain for 2.3 ms (four timeslots).

The 2.2 A current draw is for 50 ohm systems (1:1 VSWR). For worst-case antenna designs (3.5:1 VSWR), the current draw could increase to 2.5 A, as shown in the diagram.

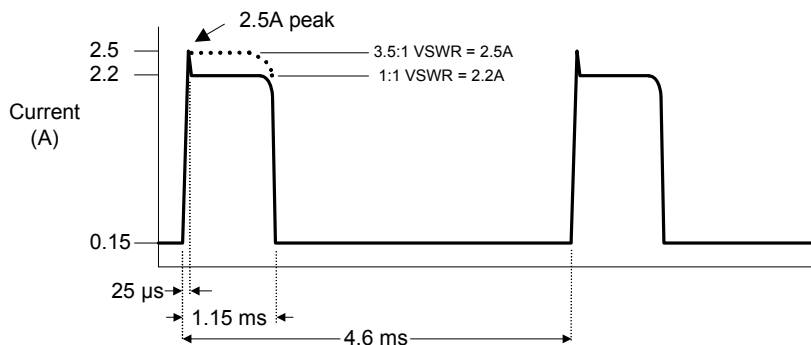

Figure 5-3: GSM transmit power waveform (class 10 operation)

Power supply noise

Noise in the power supply can lead to noise in the RF signal.

The power supply ripple limit for the module is no more than 200 mVp-p 1 Hz to 100 kHz. This limit includes voltage ripple due to transmitter burst activity.

Additional decoupling capacitors can be added to the main VCC line to filter noise into the device.

SED (Smart Error Detection)

The module uses a form of SED to track premature modem resets.

- Module tracks consecutive resets occurring soon after power-on.
- After a sixth consecutive reset, the module waits in boot-and-hold mode for a firmware download to resolve the power-cycle problem.

Tx power control

The module's Tx power limit may be controlled using either SAR backoff AT commands (defined in [2] *AirPrime MiniCard MC73xx/MC8805 AT Command Reference (Doc# 4114486)*), or the DPR (Dynamic power control) signal. Use the GPIOARENABLE parameter for !CUSTOM to choose the method:

- AT commands:
 - !SARSTATED—Set (or report) the default SAR backoff state that the device uses when it powers up. This setting persists across power cycles and overrides any PRI setting.

- !SARSTATE—Set (or report) the current SAR backoff state (override the default state). This change in state is non-persistent across power cycles.
- !SARBACKOFF—Set (or report) the maximum Tx power limit for a specific band/technology/state combination.

Note: A customization is available to invert the DPR logic. (e.g. DPR low = No SAR backoff)

- Dynamic power control—The module’s firmware monitors DPR (pin 46) and adjusts the RF Tx power appropriately, as detailed in [Table 5-9](#). (This state change is equivalent to using the !SARSTATE AT command.)

Table 5-9: Dynamic power control of SAR backoff state

DPR	SAR backoff state
High ¹	No SAR backoff
Low	Backoff 1

1. DPR is pulled high by default.

Note: The host can implement an open collector drive for the DPR pin (if a 1.8 V-compatible drive is not available.)

»» | 6: Software Interface

6

Support tools

The MC7354 is compatible with the following support tools from Sierra Wireless and authorized third parties:

- Firmware update utilities from Sierra Wireless
- Sierra Wireless Product Support Tool (SW-PST)
- CDMA Air Interface Tool (CAIT) from QUALCOMM
- Sierra Wireless Logger
- QXDM from QUALCOMM
- Noise profiling tool
- QUALCOMM Product Support Tool (QPST)
- Windows and Linux SDKs (including API and drivers)

USB interface

The device supports the Qualcomm QMI interface.

Please contact your Sierra Wireless account representative for QMI interface documentation.

MTU size (Windows 7)

The MTU (Maximum Transmission Unit) size is configured using a driver installer command line option:

MTUSize=<value> (<value> is the size in bytes)

Example:

```
driverinstaller /MTUSize=1428
```

Note: Wireless network operators will have their own specific MTU requirements.

7: Mechanical and Environmental Specifications

The MC7354 module complies with the mechanical and environmental specifications in [Table 7-1](#). Final product conformance to these specifications depends on the [OEM](#) device implementation.

Table 7-1: Mechanical and environmental specifications

	Mode	Details
Temperature	Operational	Class A ¹ : -30°C to +70°C (3GPP compliant) Class A is defined as the operating temperature range within which the device: <ul style="list-style-type: none"> • Exhibits normal function during and after environmental exposure. • Meets the minimum requirements of 3GPP, 3GPP2, or appropriate wireless standards.
		Class B ¹ : -40°C to +85°C (non-3GPP compliant) Class B is defined as the operating temperature range within which the device: <ul style="list-style-type: none"> • Remains functional during and after environmental exposure. • Exhibits the ability to establish a voice, SMS or DATA call (emergency call) at all times even when one or more environmental constraints exceed the specified tolerances.
		Internal module temperature: <ul style="list-style-type: none"> • Class A—Recommended temperature²: < 85°C (3GPP compliant) • Class B—Maximum temperature²: < 100°C (non-3GPP compliant)
	Non-operational	-40°C to +85°C, 96 hours (from MIL-STD 202 Method 108)
Relative humidity	Operational	65°C, 95% relative humidity for 10 days (non-condensing)
	Non-operational	85°C, 85% relative humidity for 48 hours (non-condensing)
Vibration	Non-operational	Random vibration, 10 to 2000 Hz, 0.1 g ² /Hz to 0.0005 g ² /Hz, in each of three mutually perpendicular axes. Test duration of 60 minutes for each axis, for a total test time of three hours.
Shock	Non-operational	Half sine shock, 11 ms, 30 g, 8x each axis. Half sine shock, 6 ms, 100 g, 3x each axis.
Drop	Non-operational	1 m on concrete on each of six faces, two times (module only).

Table 7-1: Mechanical and environmental specifications (Continued)

	Mode	Details
(Electrostatic discharge (See Electrostatic discharge (ESD) on page 68.)	Operational	The RF port (antenna launch and RF connector) complies with the IEC 61000-4-2 standard: <ul style="list-style-type: none"> Electrostatic Discharge Immunity: Test: Level3 Contact Discharge: ± 6 kV
	Non-operational	The host connector Interface complies with the following standard only: <ul style="list-style-type: none"> minimum ± 500 V Human Body Model (JESD22-A114-B)
Thermal considerations		See Thermal considerations on page 68.
Form factor		PCI-Express Mini Card shielded with metal and metalized fabric (F2 specification)
Dimensions		Length: 50.95 mm Width: 30 mm Thickness: 2.75 mm (max) Weight: 8.6 g

1. Ambient temperature (temperature around the module). Proper mounting, heat sinks and active cooling may be required, depending on the integrated application.
2. Measured by AT!PCTEMP

Device views

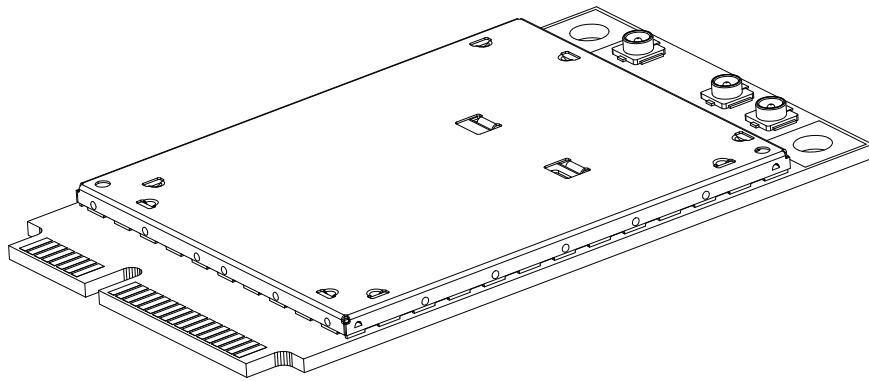

Figure 7-1: Top view

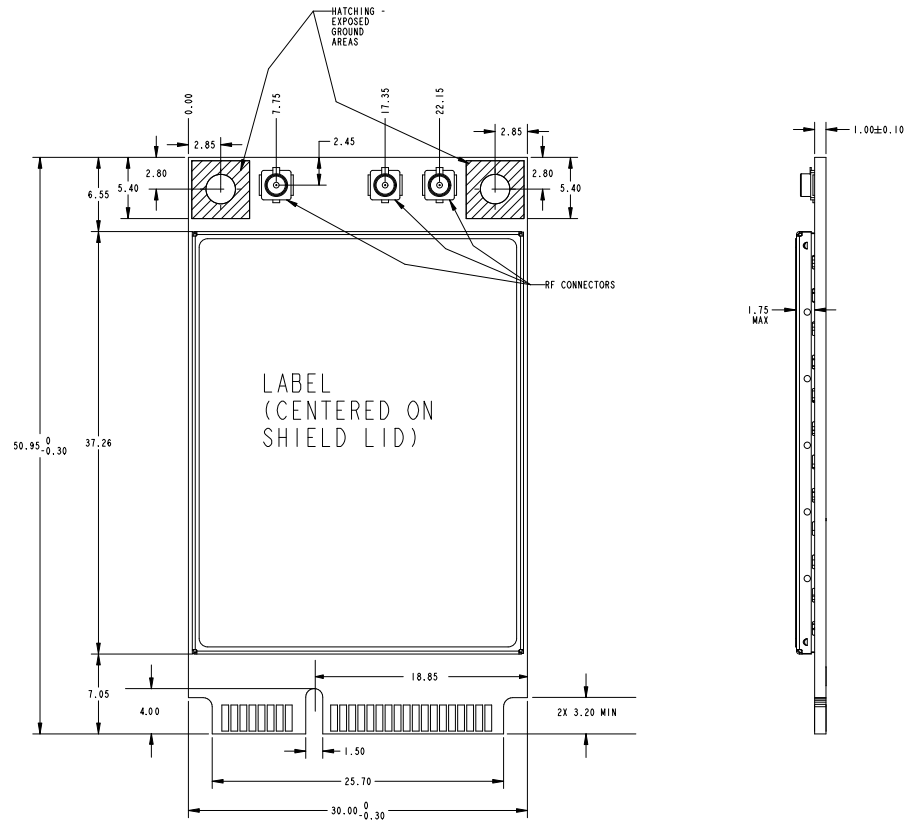

Figure 7-2: Dimensioned view

Labeling



Figure 7-3: Sample unit label

Note: The displayed label is an example only. The production label will vary by SKU.

The MC7354 label is non-removable and contains:

- Sierra Wireless logo and product name

- **IMEI** number in Code-128 barcode format
- **SKU** number (when required)
- Factory Serial Number (**FSN**) in alphanumeric format
- Manufacturing date code (incorporated into FSN)
- Licensed vendor logo
- Applicable certification marks/details (e.g. FCC ID, CE information, etc. Example shows FCC ID.)

*Note: The MC7354 supports **OEM** partner-specific label requirements.*

Electrostatic discharge (ESD)

The OEM is responsible for ensuring that the Mini Card host interface pins are not exposed to ESD during handling or normal operation. (See [Table 7-1 on page 65](#) for specifications.)

ESD protection is highly recommended for the SIM connector at the point where the contacts are exposed, and for any other signals from the host interface that would be subjected to ESD by the user of the product. (The device includes ESD protection on the antenna.)

Thermal considerations

Embedded modules can generate significant amounts of heat that must be dissipated in the host device for safety and performance reasons.

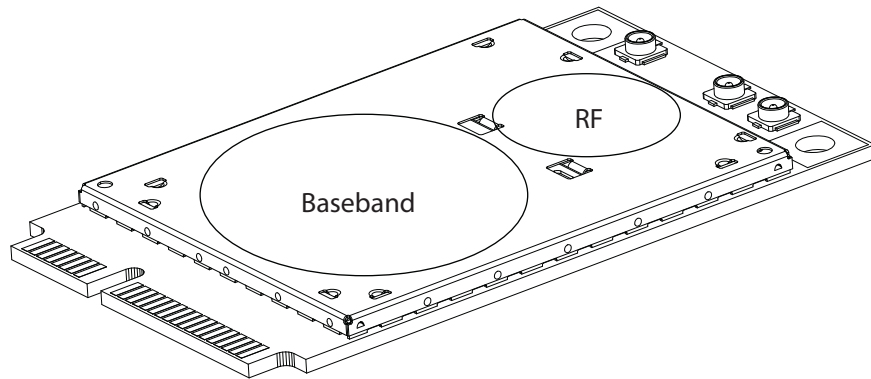

Figure 7-4: Shield locations

The amount of thermal dissipation required depends on:

- Supply voltage—Maximum power dissipation for the module can be up to 3.5 W at voltage supply limits.
- Usage—Typical power dissipation values depend on the location within the host product, throughput, amount of data transferred, etc.

Specific areas requiring heat dissipation are shown in [Figure 7-4](#):

- RF—Top and bottom faces of module near RF connectors. Likely to be the hottest area.
- Baseband—Top and bottom faces of module, below the RF area.

To enhance heat dissipation:

- Maximize airflow over/around the module.
- Locate the module away from other hot components.
- Module mounting holes must be used to attach (ground) the device to the main PCB ground or a metal chassis.
- You may need to add a heat sink that mounts the module to the main PCB (thermal compound or pads must be used between the module and the heat sink).
- You may also need active cooling to pull heat away from the module.

Note: Adequate dissipation of heat is necessary to ensure that the module functions properly.

Module integration testing

When testing your integration design:

- Test to your worst case operating environment conditions (temperature and voltage)
- Test using worst case operation (transmitter on 100% duty cycle, maximum power)
- Monitor temperature at all shield locations. Attach thermocouples to the areas indicated in [Figure 7-4](#) on page 68 (Baseband, RF).
- Monitor the module's internal temperature using the command **AT!PCTEMP**. (See [2] *AirPrime MiniCard MC73xx/MC8805 AT Command Reference* (Doc# 4114486).)

Note: Make sure that your system design provides sufficient cooling for the module—proper mounting, heat sinks, and active cooling may be required, depending on the integrated application.

The internal module temperature must be kept to <100°C when integrated to prevent damage to the module's components. For best performance, keep the internal module temperature below 85°C.

(For acceptance, certification, quality, and production (including RF) test suggestions, see [Testing on page 81](#).)

8: Regulatory Compliance and Industry Certifications

This module is designed to meet, and upon commercial release, will meet the requirements of the following regulatory bodies and regulations, where applicable:

- Federal Communications Commission (FCC) of the United States
- The Certification and Engineering Bureau of Industry Canada (IC)
- The National Communications Commission (NCC) of Taiwan, Republic of China

Upon commercial release, the following industry approvals will have been obtained, where applicable:

- PTCRB
- CDG2

Additional certifications and details on specific country approvals may be obtained upon customer request—contact your Sierra Wireless account representative for details.

Additional testing and certification may be required for the end product with an embedded MC7354 modem and are the responsibility of the [OEM](#). Sierra Wireless offers professional services-based assistance to OEMs with the testing and certification process, if required.

Important notice

Because of the nature of wireless communications, transmission and reception of data can never be guaranteed. Data may be delayed, corrupted (i.e., have errors) or be totally lost. Although significant delays or losses of data are rare when wireless devices such as the Sierra Wireless modem are used in a normal manner with a well-constructed network, the Sierra Wireless modem should not be used in situations where failure to transmit or receive data could result in damage of any kind to the user or any other party, including but not limited to personal injury, death, or loss of property. Sierra Wireless and its affiliates accept no responsibility for damages of any kind resulting from delays or errors in data transmitted or received using the Sierra Wireless modem, or for failure of the Sierra Wireless modem to transmit or receive such data.

Safety and hazards

Do not operate your MC7354 modem:

- In areas where blasting is in progress

- Where explosive atmospheres may be present including refuelling points, fuel depots, and chemical plants
- Near medical equipment, life support equipment, or any equipment which may be susceptible to any form of radio interference. In such areas, the MC7354 modem **MUST BE POWERED OFF**. Otherwise, the MC7354 modem can transmit signals that could interfere with this equipment.

In an aircraft, the MC7354 modem **MUST BE POWERED OFF**. Otherwise, the MC7354 modem can transmit signals that could interfere with various onboard systems and may be dangerous to the operation of the aircraft or disrupt the cellular network. Use of a cellular phone in an aircraft is illegal in some jurisdictions. Failure to observe this instruction may lead to suspension or denial of cellular telephone services to the offender, or legal action or both.

Some airlines may permit the use of cellular phones while the aircraft is on the ground and the door is open. The MC7354 modem may be used normally at this time.

Important compliance information for North American users

The MC7354 modem has been granted modular approval for mobile applications. Integrators may use the MC7354 modem in their final products without additional FCC/IC (Industry Canada) certification if they meet the following conditions. Otherwise, additional FCC/IC approvals must be obtained.

1. At least 20 cm separation distance between the antenna and the user's body must be maintained at all times.
2. To comply with FCC / IC regulations limiting both maximum RF output power and human exposure to RF radiation, the maximum antenna gain including cable loss in a mobile-only exposure condition must not exceed:
 - 4.0 dBi in Cellular band
 - 3.0 dBi in PCS band
 - 3.0 dBi in LTE Band 2
 - 4.0 dBi in LTE Band 4
 - 4.0 dBi in LTE Band 5
 - 4.0 dBi in LTE Band 13
 - 4.0 dBi in LTE Band 17
 - 3.0 dBi in LTE Band 25
3. The MC7354 modem may transmit simultaneously with other collocated radio transmitters within a host device, provided the following conditions are met:
 - Each collocated radio transmitter has been certified by FCC/IC for mobile application.
 - At least 20 cm separation distance between the antennas of the collocated transmitters and the user's body must be maintained at all times.

- The output power and antenna gain in a collocated configuration must not exceed the limits and configurations stipulated in the following table.

Table 8-1: Collocated configuration specifications

Device	Technology	Band	Frequency (MHz)	Collocated configuration	
				Maximum antenna gain (dBi)	Maximum conducted power (dBm)
MC7354 Mini Card	LTE	2	1850–1910	3.0	See Table 4-10 on page 51 .
		4	1710–1755	4.0	
		5	824–849	4.0	
		13	777–787	4.0	
		17	704–716	4.0	
		25	1850–1915	3.0	
	UMTS	2	1850–1910	3.0	See Table 4-10 on page 51 .
		4	1710–1755	4.0	
		5	824–849	4.0	
	GSM	Cellular (850)	824–849	4.0	See Table 4-10 on page 51 .
		PCS (1900)	1850–1910	3.0	
	CDMA	BC0	824–849	4.0	See Table 4-10 on page 51 .
		BC1	1850–1910	3.0	
		BC10	817–824	4.0	
	Collocated transmitters ¹	WLAN		2400–2500	5.0
			5150–5850	5.0	29
WiMAX			2300–2400	5.0	29
			2500–2700	5.0	29
			3300–3800	5.0	29
BT			2400–2500	5.0	15

1. Valid collocated transmitter combinations: WLAN+BT; WiMAX+BT.
(WLAN+WiMAX+BT is not permitted.)

4. A label must be affixed to the outside of the end product into which the MC7354 modem is incorporated, with a statement similar to the following:
 - **This device contains FCC ID: N7NMC7354.**
Contains transmitter module IC: 2417C-MC7354 where 2417C-MC7354 is the module's certification number.

5. A user manual with the end product must clearly indicate the operating requirements and conditions that must be observed to ensure compliance with current FCC / IC RF exposure guidelines.

The end product with an embedded MC7354 modem may also need to pass the FCC Part 15 unintentional emission testing requirements and be properly authorized per FCC Part 15.

Note: If this module is intended for use in a portable device, you are responsible for separate approval to satisfy the SAR requirements of FCC Part 2.1093 and IC RSS-102.

>> A: Antenna Specification

This appendix describes recommended electrical performance criteria for main path, diversity path, and GNSS antennas used with AirPrime embedded modules.

The performance specifications described in this section are valid while antennas are mounted in the host device with antenna feed cables routed in their final application configuration.

*Note: Antennas should be designed **before** the industrial design is finished to make sure that the best antennas can be developed.*

Table A-1: Antenna requirements ^a

Parameter	Requirements	Comments
Antenna system	External multi-band 2x2 MIMO antenna system (Ant1/Ant2) ^b	If Ant2 includes GNSS, then it must also satisfy requirements in Table A-2 on page 77 .
Operating bands— Antenna 1	704–960 MHz	
	1710–1995 MHz	
	2110–2170 MHz	
Operating bands— Antenna 2	734–960 MHz	
	1930–1995 MHz	
	2110–2170 MHz	
VSWR of Ant1 and Ant2	<ul style="list-style-type: none"> < 2:1 (recommended) < 3:1 (worst case) 	On all bands including band edges
Total radiated efficiency of Ant1 and Ant2	> 50% on all bands	<ul style="list-style-type: none"> Measured at the RF connector. Includes mismatch losses, losses in the matching circuit, and antenna losses, excluding cable loss. Sierra Wireless recommends using antenna efficiency as the primary parameter for evaluating the antenna system. Peak gain is not a good indication of antenna performance when integrated with a host device (the antenna does not provide omni-directional gain patterns). Peak gain can be affected by antenna size, location, design type, etc.—the antenna gain patterns remain fixed unless one or more of these parameters change.

Table A-1: Antenna requirements (Continued)^a

Parameter	Requirements	Comments
Radiation patterns of Ant1 and Ant2	Nominally Omni-directional radiation pattern in azimuth plane.	
Envelope correlation coefficient between Ant1 and Ant2	<ul style="list-style-type: none"> < 0.4 on 793–894 MHz and 925–960 MHz bands < 0.2 on 1930–1995 MHz and 2110–2170 MHz bands 	
Mean Effective Gain of Ant1 and Ant2 (MEG1, MEG2)	≥ -3 dBi	
Ant1 and Ant2 Mean Effective Gain Imbalance I MEG1 / MEG2 I	< 2 dB for MIMO operation < 6 dB for diversity operation	
Maximum antenna gain	Must not exceed antenna gains due to RF exposure and ERP/ EIRP limits, as listed in the module's FCC grant.	See Important compliance information for North American users on page 72 .
Isolation between Ant1 and Ant2 (S21)	> 10 dB	<ul style="list-style-type: none"> If antennas can be moved, test all positions for both antennas. Make sure all other wireless devices (Bluetooth or WLAN antennas, etc.) are turned OFF to avoid interference.
Power handling	<ul style="list-style-type: none"> > 2 W RF power on low bands > 1 W on high bands 	<ul style="list-style-type: none"> Measure power endurance over 4 hours (estimated talk time) using a 2 W CW signal—set the CW test signal frequency to the middle of the PCS Tx band (1880 MHz for PCS). Visually inspect device to ensure there is no damage to the antenna structure and matching components. VSWR/TIS/TRP measurements taken before and after this test must show similar results.

a. These worst-case VSWR figures for the transmitter bands may not guarantee RSE levels to be within regulatory limits. The device alone meets all regulatory emissions limits when tested into a cabled (conducted) 50 ohm system. With antenna designs with up to 2.5:1 VSWR or worse, the radiated emissions could exceed limits. The antenna system may need to be tuned in order to meet the RSE limits as the complex match between the module and antenna can cause unwanted levels of emissions. Tuning may include antenna pattern changes, phase/delay adjustment, passive component matching. Examples of the application test limits would be included in FCC Part 22, Part 24 and Part 27, test case 4.2.16 for GSM (ETSI EN 301 511), and test case 4.2.2 for WCDMA (ETSI EN 301 908-1), where applicable.

b. Ant1—Primary, Ant2—Secondary (Diversity/MIMO/GNSS connector 2)

Recommended GNSS antenna specifications

Table A-2: GNSS standalone antenna requirements

Parameter	Requirements	Comments
Frequency range	<ul style="list-style-type: none"> Narrow-band GPS: 1575.42 MHz \pm2 MHz minimum Wide-band GPS and GLONASS: 1565–1606 MHz recommended 	
Field of view (FOV)	<ul style="list-style-type: none"> Omni-directional in azimuth -45° to +90° in elevation 	
Polarization (average Gv/Gh)	> 0 dB	Vertical linear polarization is sufficient.
Free space average gain (Gv+Gh) over FOV	> -6 dBi (preferably > -3 dBi)	Gv and Gh are measured and averaged over -45° to +90° in elevation, and \pm 180° in azimuth.
Gain	<ul style="list-style-type: none"> Maximum gain and uniform coverage in the high elevation angle and zenith. Gain in azimuth plane is not desired. 	
Average 3D gain	> -5 dBi	
Isolation between GNSS and Ant1	> 10 dB in all uplink bands	
Typical VSWR	< 2.5:1	
Polarization	Any other than LHCP (left-hand circular polarized) is acceptable.	

Antenna tests

The following guidelines apply to the requirements described in [Table A-1 on page 75](#) and [Table A-2 on page 77](#):

- Perform electrical measurements at room temperature (+20°C to +26°C) unless otherwise specified
- For main and diversity path antennas, make sure the antennas (including contact device, coaxial cable, connectors, and matching circuit with no more than six components, if required) have nominal impedances of 50 Ω across supported frequency bands.
- All tests (except isolation/correlation coefficient)—Test the main or diversity antenna with the other antenna terminated.

- Any metallic part of the antenna system that is exposed to the outside environment needs to meet the electrostatic discharge tests per IEC61000-4-2 (conducted discharge +8kV).
- The functional requirements of the antenna system are tested and verified while the embedded module's antenna is integrated in the host device.

Note: Additional testing, including active performance tests, mechanical, and accelerated life tests can be discussed with Sierra Wireless' engineering services. Contact your Sierra Wireless representative for assistance.

» B: Design Checklist

B

This chapter provides a summary of the design considerations mentioned throughout this guide. This includes items relating to the power interface, RF integration, thermal considerations, cabling issues, and so on.

Note: This is NOT an exhaustive list of design considerations. It is expected that you will employ good design practices and engineering principles in your integration.

Table B-1: Hardware integration design considerations

Suggestion	Section where discussed
Component placement	
Protect the SIM socket so the SIM cannot be removed while the host is powered up.	SIM implementation on page 35
If an ESD suppressor is not used, allow space on the SIM connector for series resistors in layout. (Up to 100 Ω may be used depending on ESD testing requirements).	SIM implementation on page 35
Minimize RF cable losses as these affect performance values listed in product specification documents.	RF connections on page 43
Antennas	
Match the module/antenna coax connections to 50 Ω —mismatched antenna impedance and cable loss negatively affect RF performance.	RF connections on page 43
If installing CDMA and UMTS modules in the same device, consider using separate antennas for maximum performance.	Antenna and cabling on page 44
Power	
Make sure the power supply can handle the maximum current specified for the module type.	Power consumption on page 55
Limit the total impedance of VCC and GND connections to the SIM at the connector to less than 1 Ω (including any trace impedance and lumped element components—inductors, filters, etc.). All other lines must have a trace impedance less than 2 Ω .	SIM implementation on page 35
Decouple the VCC line close to the SIM socket. The longer the trace length (impedance) from socket to module, the greater the capacitance requirement to meet compliance tests.	SIM implementation on page 35
EMI/ESD	
Investigate sources of localized interference early in the design cycle.	Methods to mitigate decreased Rx performance on page 46
Provide ESD protection for the SIM connector at the exposed contact point (in particular, the CLK, VCC, IO, and RESET lines).	SIM implementation on page 35

Table B-1: Hardware integration design considerations (Continued)

Suggestion	Section where discussed
Keep very low capacitance traces on the USIM_DATA and USIM_CLK signals.	SIM implementation on page 35
To minimize noise leakage, establish a very good ground connection between the module and host.	Ground connection on page 45
Route cables away from noise sources (for example, power supplies, LCD assemblies, etc.).	Methods to mitigate decreased Rx performance on page 46
Shield high RF-emitting components of the host device (for example, main processor, parallel bus, etc.).	Methods to mitigate decreased Rx performance on page 46
Use discrete filtering on low frequency lines to filter out unwanted high-order harmonic energy.	Methods to mitigate decreased Rx performance on page 46
Use multi-layer PCBs to form shielding layers around high-speed clock traces.	Methods to mitigate decreased Rx performance on page 46
Thermal	
Test to worst case operating conditions—temperature, voltage, and operation mode (transmitter on 100% duty cycle, maximum power).	Thermal considerations on page 68
Use appropriate techniques to reduce module temperatures (for example, airflow, heat sinks, heat-relief tape, module placement, etc.).	Thermal considerations on page 68
Host/Modem communication	
Make sure the host USB driver supports remote wakeup, resume, and suspend operations, and serial port emulation.	<i>[4] AirCard/AirPrime USB Driver Developer's Guide (Doc# 2130634)</i>
When no valid data is being sent, do not send SOF tokens from the host (causes unnecessary power consumption).	<i>[4] AirCard/AirPrime USB Driver Developer's Guide (Doc# 2130634)</i>

Note: All AirPrime embedded modules are factory-tested to ensure they conform to published product specifications.

Developers of OEM devices integrating Sierra Wireless AirPrime embedded modules should include a series of test phases in their manufacturing process to make sure that *their* devices work properly with the embedded modules.

Suggested phases include:

- [Acceptance testing](#)—Testing of modules when they are received from Sierra Wireless
- [Certification testing](#)—Testing of completed devices to obtain required certifications before beginning mass production
- [Production testing](#)—Testing of completed devices with the modules embedded
- [Quality assurance testing](#)—Post-production

AT command entry timing requirement

Some AT commands require time to process before additional commands are entered. For example, the modem will return “OK” when it receives `AT!DAFTMACT`. However, if `AT!DASBAND` is received too soon after this, the modem will return an error.

When building automated test scripts, ensure that sufficient delays are embedded where necessary to avoid these errors.

Acceptance testing

*Note: Acceptance testing is typically performed for **each** shipment received.*

When you receive a shipment from Sierra Wireless, you should make sure it is suitable before beginning production.

From a random sampling of units, test that:

- Units are operational
- Units are loaded with the correct firmware version

Acceptance test requirements

To perform the suggested tests, you require a test system in which to temporarily install the module, and you must be able to observe the test device's LED indicator.

Acceptance test procedure

The following is a suggested acceptance testing procedure using Sierra Wireless' Skylight™ (formerly Watcher™) software:

Note: You can perform these tests using appropriate AT commands.

Test 1: Check power-up and initialization

1. After installing the module, start the test system.
2. Launch Skylight.
3. Check the LED—If the LED is off, there is a problem with the module or with the connection to the LED.

Test 2: Check version numbers

1. From Skylight, select **Help > About**.
2. Verify that the firmware version in the **About** window is correct.
3. Close the **About** window.

If the module fails either of these tests, or is not recognized by Skylight:

1. Replace the module with one that is known to work correctly and repeat the tests.
2. If the tests are successful, reinstall the original module and repeat the tests.

If the module still does not work correctly, contact your account manager.

Certification testing

Note: Typically, certification testing of your device with the integrated module is required one time only.

The AirPrime embedded module has been certified as described in [Regulatory Compliance and Industry Certifications on page 71](#).

When you produce a host device with a Sierra Wireless AirPrime embedded module, you must obtain certifications for the final product from appropriate regulatory bodies in the jurisdictions where it will be distributed.

The following are *some* of the regulatory bodies from which you may require certification—it is your responsibility to make sure that you obtain all necessary certifications for your product from these or other groups:

- FCC (Federal Communications Commission—www.fcc.gov)
- Industry Canada (www.ic.gc.ca)
- CDG (CDMA Development Group—www.cdg.org)

- GCF (Global Certification Forum—www.globalcertificationforum.org) outside of North America
- PTCRB (PCS Type Certification Review Board—www.ptcrb.com) in North America

Production testing

Note: Production testing typically continues for the life of the product.

Production testing ensures that, for each assembled device, the module is installed correctly (I/O signals are passed between the host and module), and the antenna is connected and performing to specifications (RF tests).

Typical items to test include:

- Host connectivity
- Baseband (host/module connectors)
- RF assembly (Tx and/or Rx, as appropriate)
- Network availability
- Host/device configuration issues

*Note: The amount and types of tests to perform are **your** decision—the tests listed in this section are guidelines only. Make sure that the tests you perform exercise functionality to the degree that **your** situation requires.*

Use an appropriate test station for your testing environment (see [Acceptance test requirements on page 82](#) for suggestions) and use AT commands to control the integrated module.

Note: Your test location must be protected from ESD to avoid interference with the module and antenna(s), assuming that your test computer is in a disassembled state. Also, consider using an RF shielding box—local government regulations may prohibit unauthorized transmissions.

Functional production test

This section presents a suggested procedure for performing a basic manual functional test on a laboratory bench using an AirPrime embedded module and a Mini Card Dev Kit. When you have become familiar with the testing method, use it to develop your own automated production testing procedures.

Suggested production tests

Consider the following tests when you design your production test procedures for devices with the AirPrime module installed.

- Visual check of the module's connectors and RF assemblies
- Module is operational

- USB connection is functional
- LED is functional
- W_DISABLE_N (enter low power mode)
- Firmware revision check
- Rx tests on main and auxiliary paths
- Tx test

Production test procedure

The following is a suggested test plan—you must decide which tests are appropriate for your product. You may wish to add additional tests that more fully exercise the capabilities of your product.

Using an appropriate Dev Kit-based test station, and referring to the appropriate AT command references:

1. Visually inspect the module's connectors and RF assemblies for obvious defects before installing it in the test station.
2. Ensure that the module is powered off (no voltage on VCC).
3. If using Linux, determine if any USB devices are currently connected to the computer:
 - a. Open a shell window and enter the command `ls /dev/tty/USB*`.
 - b. Record the `ttyUSBn` values that are returned; these are the currently connected USB devices. If the command returns “no such file or directory”, there are no devices currently connected.
4. Provide power to the module (voltage on VCC).
5. Test W_DISABLE_N.
6. Test USB functionality—Check for USB enumeration.
 - (Windows systems) The Device Manager shows the device under Network adapters. For example:



- (Linux systems) Enter the command `ls /dev/tty/USB*` and then record and compare the results with those from [Step 3](#). If there are any new `ttyUSBn` devices, then the modem has enumerated successfully. (The AT port is the *last* new device.)
7. Make sure your modem is connected and running, and then establish contact with the module:
 - **Windows systems:** Use a terminal emulation/communications program such as Microsoft HyperTerminal® to connect to the Sierra Wireless modem (see listings in [Step 6](#)):
 - a. Start HyperTerminal.

- b. Select **File > Connection Description**. The Connection Description dialog box appears.
 - i. Type Sierra in the Name box and click **OK**. The Connect To dialog box appears.
 - ii. Click **OK** without changing any of the displayed information. The Connect dialog box appears.
 - iii. Click **Cancel**.
 - iv. Type **ATZ** in the HyperTerminal window. If the connection is established, the message OK appears.
- **Linux systems:** Use a terminal emulation/communications program such as minicom to connect over the device handle for AT commands (see listings in [Step 6](#)):

*Note: If necessary, use **ATE1** to enable echo.*

Note: If the command “minicom” is not found, then use a different program, or download minicom and repeat this step. See [Downloading and configuring minicom for Linux systems on page 86](#) for details.

- i. Start minicom:
 - First use of the modem: From the command line, type minicom -s. (The ‘-s’ switch shows the configuration menu.)
 - Subsequent uses: From the command line, type minicom. (The ‘-s’ switch is assumed.)

The minicom configuration details appear and the message OK appears when the connection is established.

```

cx Telnet 00.0.00.00
Welcome to minicom 2.2
OPTIONS: I18n
Compiled on Apr 27 2007, 15:50:20.
Port /dev/ttyUSB2

Press CTRL-A Z for help on special keys

AT S7=45 S0=0 L1 U1 X4 &c1 E1 Q0
OK
CTRL-A Z for help !115200 8N1 ! NOR ! Minicom 2.2 ! UT102 ! Offline
  
```

8. Display the firmware version:
 - **ATI**
9. Test the LED—Set the LED in blinking mode using this command, then visually verify that the LED turns off and on:
 - **AT!LDTEST=0,0** (LED on)
 - **AT!LDTEST=0,1** (LED off)
10. Unlock the extended AT command set:
 - **AT!ENTERCND**
11. Put the module in diagnostic/factory test mode:
 - **AT!DAFTMACT**
12. Communicate with the SIM using **+CPIN** or **+CIMI**.
When performing RF tests, use a test platform as described in [Suggested testing equipment on page 93](#).
13. Test RF transmission, if desired:
 - (UMTS) See [UMTS \(WCDMA/GSM\) RF transmission path test on page 87](#). Note: The CDMA paths (BC0, BC1, and BC10) are tested by testing UMTS Band 5 (850 MHz) and Band 2 (1900 MHz). A separate test is not required.
 - (LTE) To test the LTE transmission path, use a call box.

14. Test RF reception, if desired:
 - (UMTS) See [UMTS \(WCDMA/GSM\) RF receive path test on page 89](#).
Note: The CDMA paths (BC0, BC1, and BC10) are tested by testing UMTS Band 5 (850 MHz) and Band 2 (1900 MHz). A separate test is not required.
 - (LTE) See [LTE RF receive path test on page 91](#).
15. Test standalone GNSS functionality—See [GNSS RF receive path test on page 92](#).

Downloading and configuring minicom for Linux systems

Note: This procedure is for Ubuntu systems. If you are using a different Linux distribution, use the appropriate commands for your system to download minicom.

To download and configure minicom in a Ubuntu system:

Note: To install minicom, you must have root access, or be included in the sudoers list.

1. Download and install minicom—enter the following command:
`sudo apt-get install minicom`
2. When prompted, enter your user password to begin the download and installation. When minicom is installed, the shell prompt appears.
3. Configure minicom to communicate with your modem:
 - a. Start minicom with the following command:
`minicom -s`
4. Use the down-arrow key to select the **Serial port setup** option.
5. Refer to [Step 6](#) on page 84 to identify the device file handle (/dev/ttyUSBn) used for AT commands.
6. Indicate the file handle to use for AT commands—Enter A and then replace the serial device string with the AT file handle.
7. Press **Enter** twice.
8. Use the down-arrow key to select **Save setup as dfi**.
9. Select **Exit**.

UMTS (WCDMA/GSM) RF transmission path test

Note: This procedure segment is performed in [Step 13](#) of the [Production test procedure on page 84](#).

The suggested test procedure that follows uses the parameters in [Table C-1](#).

Table C-1: Test settings—UMTS transmission path

Mode	Test category	850 MHz	900 MHz	1700 MHz	1800 MHz	1900 MHz	2100 MHz
WCDMA	Band #	B5	B8	B4	n/a	B2	B1
	Band ID	22	29	28		15 ^a	9
	Uplink Channel ^b	4182	2812	1410		9400	9750
GSM	Band #	GSM850	GSM900	n/a	DCS1800	PCS1900	n/a
	Band ID	18	10		11	12	
	Uplink Channel ^b	190	65		697	661	

a. Either 15 (WCDMA1900A) or 16 (WCDMA1900B) may be used for testing.

b. Channel values shown are at the center of the corresponding bands.

To test the DUT's transmitter path:

1. Set up the power meter:

Note: This procedure describes steps using the "Power Meter: Gigatronics 8651A" (with Option 12 and Power Sensor 80701A).

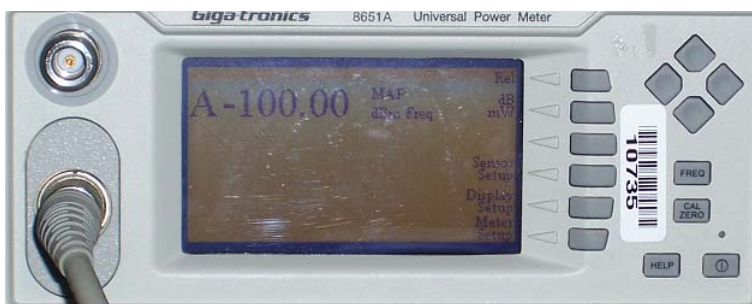

- a. Make sure the meter has been given sufficient time to warm up, if necessary, to enable it to take accurate measurements.
 - b. Zero-calibrate the meter.
 - c. Enable MAP mode.
2. Prepare the DUT using the following AT commands:
- a. `ATIINTERCND=<password>` (Unlock extended AT command set.)
 - b. `ATIDAFTMACT` (Enter test mode.)
 - c. `ATIDASBAND=<bandValue>` (Set frequency band.)
 - See [Table C-1 on page 87](#) for appropriate <bandValue> values
 - d. `ATIDASCHAN=<channel>` (Set modem channel)
 - See [Table C-1 on page 87](#) for appropriate <channel> values

- e. (GSM mode only)
ATIDAGSTXFRAME=0, 1, 3000, 0 (Set Tx frame structure.)
 - f. **ATIDASTXON** (Turns on the transmit path.)
 - g. (WCDMA mode only)
ATIDAWSTXCW=0 (Use a modulated carrier.)
ATIDASPDM=2, 75 (Set the power level. Repeat command with different offsets until desired Tx power is obtained.)
ATIDAWSPARANGE=3 (Set to high PA gain state.)
 - h. Offset the tracking (If necessary, repeat with different offsets until the desired frequency is obtained.)
(WCDMA mode) **ATIDASPDM=4,35100**
(GSM mode) **ATIDASPDM=0,2240**
 - i. Take the measurement.
 - j. **ATIDASTXOFF** (Turn off the transmitter.)
3. Test limits—Run ten or more good DUTs through this test procedure to obtain a nominal output power value.
- Apply a tolerance of ± 5 to 6 dB to each measurement (assuming a good setup design).
 - Monitor these limits during mass-production ramp-up to determine if further adjustments are needed.
 - For GSM mode, the transmit signal is bursted, so the transmit power will appear averaged on the power meter reading.

Note: The module has a nominal output power of +23 dBm ± 1 dB in WCDMA mode. However, the value measured by the power meter is significantly influenced (beyond the stated ± 1 dB output power tolerance) by the test setup (host RF cabling loss, antenna efficiency and pattern, test antenna efficiency and pattern, and choice of shield box).

Note: When doing the same test over the air in an RF chamber, values are likely to be significantly lower.

UMTS (WCDMA/GSM) RF receive path test

Note: This procedure segment is performed in [Step 14](#) of the [Production test procedure](#) on [page 84](#).

The suggested test procedure that follows uses the parameters in [Table C-2](#).

Table C-2: Test settings—WCDMA/GSM receive path

Mode	Test category	850 MHz	900 MHz	1800 MHz	1900 MHz	2100 MHz	
WCDMA	Band #	B5	B8	n/a	B2	B1	B4
	Frequency ^a (MHz)	882.6	948.6		1961.2	2141.2	2133.2
	Band ID	22	29		15 ^b	9	28
	Uplink Channel ^c	4182	2812		9400	9750	1410
GSM	Band #	GSM850	GSM900	DCS1800	PCS1900	n/a	n/a
	Frequency ^d (MHz)	881.667	948.067	1842.267	1960.067		
	Band ID	18	10	11	12		
	Uplink Channel ^c	190	65	697	661		

- Receive frequencies shown are +1.2 MHz offset from center
- Either 15 (WCDMA1900A) or 16 (WCDMA1900B) may be used for testing.
- Channel values shown are at the center of the corresponding bands.
- Receive frequencies shown are +0.067 MHz offset from center.

To test the DUT's receive path:

- Set up the signal generator:

Note: This procedure describes steps using the Agilent 8648C signal generator—the Rohde & Schwarz SML03 is shown for reference only.

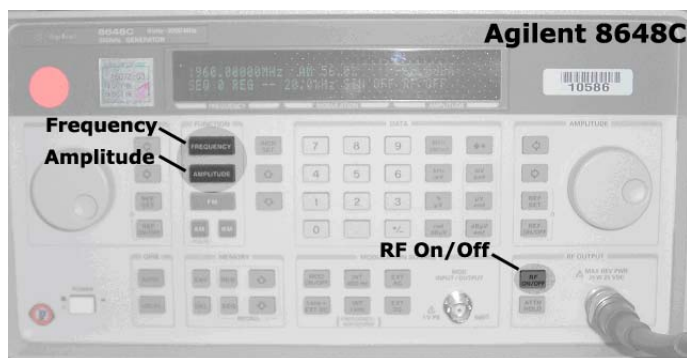

- Set the amplitude to:
 - 80 dBm (WCDMA mode)
 - 60 dBm (GSM mode)

- vi. ATIDASLNAGAIN=0 (Set the LNA to maximum gain.)
 - vii. ATIDAWGAVGAGC=9400,0,1 (The '1' indicates the diversity path is used.)
- c. Test the limits as in [Step 3](#).

LTE RF receive path test

Note: This procedure segment is performed in [Step 14](#) of the [Production test procedure on page 84](#).

The suggested test procedure that follows uses the parameters in [Table C-3](#).

Table C-3: Test settings—LTE receive path

Mode	Test category	700 MHz		850 MHz	1700 MHz	1900 MHz (G Block)	1900 MHz
LTE	Band #	B13	B17	B5	B4	B25	B2
	Frequency ^a (MHz)	753.0	742.0	883.5	2134.5	1964.5	1962.0
	Band ID	36	37	45	42	61	43
	Uplink Channel ^b	23230	23790	20525	20175	26365	18900

- a. Receive frequencies shown are +2 MHz offset from center
- b. Channel values shown are at the center of the corresponding bands.

To test the DUT's receive path (or diversity path, while connected to the diversity antenna):

1. Set up the signal generator:

Note: This procedure describes steps using the Agilent 8648C signal generator—the Rohde & Schwarz SML03 is shown for reference only.

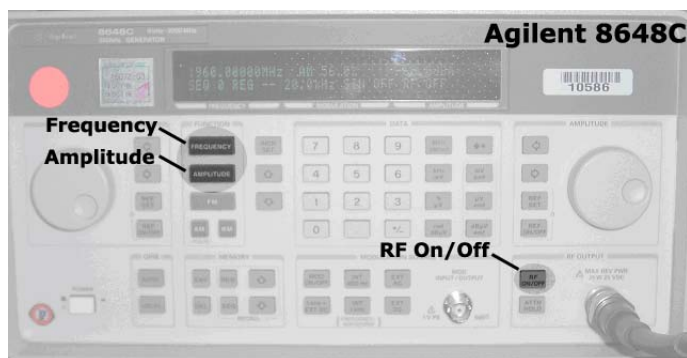

- a. Set the amplitude to -70 dBm
- b. Set the frequency for the band being tested. See [Table C-3 on page 91](#) for frequency values.

2. Set up the DUT:
 - a. **ATIINTERCND** (Unlock extended AT command set.)
 - b. **ATIDAFTMACT** (Put modem into factory test mode.)
 - c. **ATIDASBAND=<band>** (Set frequency band.)
 - See [Table C-3 on page 91](#) for <band> values
 - d. **ATIDALSTXBW=<bw>** (Set Tx bandwidth.)
 - e. **ATIDALSRXBW=<bw>** (Set Rx bandwidth.)
 - f. **ATIDASCHAN=<channel>** (Set modem channel.)
 - See [Table C-3 on page 91](#) for <channel> values
 - g. **ATIDALGAVGAGC=<channel>,0** (Get averaged Rx AGC.)
 - See [Table C-3 on page 91](#) for <channel> values
3. Test limits—Run ten or more good DUTs through this test procedure to obtain a nominal received power value.
 - Apply a tolerance of ± 5 to 6 dB to each measurement (assuming a good setup design).
 - Make sure the measurement is made at a high enough level that it is not influenced by DUT-generated and ambient noise.
 - The Signal Generator power level can be adjusted and new limits found if the radiated test needs greater signal strength.
 - Monitor these limits during mass-production ramp-up to determine if further adjustments are needed.

Note: The value measured from the DUT is significantly influenced by the test setup and DUT design (host RF cabling loss, antenna efficiency and pattern, test antenna efficiency and pattern, and choice of shield box).

GNSS RF receive path test

The GNSS receive path uses either the dedicated GNSS connector or the shared Diversity/MIMO/GNSS connector.

To test the GNSS receive path:

1. Inject a carrier signal at -110dBm, frequency 1575.52 MHz into the GNSS Rx path at the connector. (Note that this frequency is 100 kHz higher than the actual GPS L1 center frequency.)
2. Test the signal carrier-to-noise level at the GNSS receiver:
 - a. **ATIINTERCND** (Unlock extended AT command set.)
 - b. **ATIDAFTMACT** (Put modem into factory test mode.)
 - c. **ATIDACGPSTESTMODE=1** (Start CGPS diagnostic task.)
 - d. **ATIDACGPSSTANDALONE=1** (Enter standalone RF mode.)
 - e. **ATIDACGPSMASKON** (Enable log mask.)
 - f. **ATIDACGPSCTON** (Return signal-to-noise and frequency measurements.)
 - g. Repeat **ATIDACGPSCTON** five to ten times to ensure the measurements are repeatable and stable.

3. Leave the RF connection to the Mini Card device intact, and turn off the signal generator.
4. Take several more **IDACGPSTON** readings. This will demonstrate a 'bad' signal in order to set limits for testing, if needed. This frequency offset should fall outside of the guidelines in the note below, which indicates that the CtoN result is invalid.
5. (Optional) Turn the signal generator on again, and reduce the level to -120dBm. Take more **IDACGPSTON** readings and use these as a reference for what a marginal/poor signal would be.

*Note: The response to **ATIDACGPSTON** for a good connection should show CtoN within 58 +/- 5dB and Freq (frequency offset) within 100000 Hz +/- 5000 Hz .*

Quality assurance testing

Note: QA is an ongoing process based on random samples from a finished batch of devices.

The quality assurance tests that you perform on your finished products should be designed to verify the performance and quality of your devices.

The following are *some* testing suggestions that can confirm that the antenna is interfaced properly, and that the RF module is calibrated and performs to specifications:

- Module registration on cellular networks
- Power consumption
- Originate and terminate data and voice (if applicable) calls
- Cell hand-off
- Transmitter and receiver tests
- FER (Frame Error Rate) as an indicator of receiver sensitivity/performance
- Channel and average power measurements to verify that the device is transmitting within product specifications
- CDMA:
 - FER testing—Test receiver sensitivity for conditions of minimum cell power. FER can be measured for the specified receiver sensitivity of -104 dBm. The objective of this test is to determine if the FER measured is within the acceptable limits for the specified receiver sensitivity of the module. Unlike the FER tests performed during production testing, this test determines the receiver performance without the influence of the noise factor (AWGN), but with extremely low cell power. The reported FER and the confidence level must be <1% and >95% respectively for the test to be considered a pass.
- (UMTS) RF sensitivity testing—BER/BLER for different bands and modes
- (UMTS) Transmitter and receiver tests (based on relevant sections of the 3GPP TS51010 and 3GPP 34121 documents)

Suggested testing equipment

To perform production and post-production tests, you will require appropriate testing equipment. A test computer can be used to coordinate testing between the integrated module (on the development kit or host) and the measurement

equipment, usually with GPIB connections. The suggested setup includes a power meter to test RF output power and a signal generator to evaluate the receiver.

Testing assistance provided by Sierra Wireless

Extended AT commands have been implemented to assist with performing FTA GCF tests and portions of CE Mark tests requiring radio module access. These are documented in the [2] *AirPrime MiniCard MC73xx/MC8805 AT Command Reference (Doc# 4114486)*.

Sierra Wireless offers optional professional services based assistance to [OEMs](#) with regulatory approvals.

IOT/Operator testing

Interoperability and Operator/Carrier testing of the finished system is the responsibility of the [OEM](#). The test process will be determined with the chosen network operator(s) and will be dependent upon your business relationship with them, as well as the product's application and sales channel strategy.

Sierra Wireless offers assistance to OEMs with the testing process, if required.

Extended AT commands for testing

Sierra Wireless provides the [2] *AirPrime MiniCard MC73xx/MC8805 AT Command Reference (Doc# 4114486)*, which describes proprietary AT commands that may help in hardware integration design and testing (these commands are NOT intended for use by end users).

Some commands from this document that may be useful for hardware integration are listed in [Table C-4 on page 94](#).

Table C-4: Extended AT commands

Command	Description
Password commands	
!ENTERCND	Enable access to password-protected commands
!SETCND	Set AT command password
Modem reset and status commands	
!GRESET	Reset the modem
!GSTATUS	Return the operation status of the modem (mode, band, channel, and so on)

Table C-4: Extended AT commands

Command	Description
Diagnostic commands	
!BAND	Select a set of frequency bands or reports current selection
!GBAND	Read/set the current operating band
Test commands	
!ALLUP	Turn transmitter on/off and simulate 'All UPs'
!DAFTMACT	Put the modem into FTM (Factory Test Mode)
!DAFTMDEACT	Put the modem into online mode
!DAGRSSI	Return the RSSI (Received Signal Strength Indicator) in dBm (GSM mode)
!DAGGAVGRSSI	Return an averaged RSSI (Received Signal Strength Indicator) in dBm (GSM mode)
!DAGGRSSIRAW	Return the raw RSSI (GSM mode)
!DAGINFO	Return GSM mode RF information
!DAGSLOCK	Return the RF synthesizer lock state
!DAGSRXBURST	Set the GSM receiver to burst mode
!DAGSRXCONT	Set the GSM receiver continually on
!DAGSTXBURST	Set the GSM transmitter to burst mode
!DAGSTXFRAME	Set the GSM Tx frame structure
!DALGAVGAGC	Return averaged Rx AGC value (LTE)
!DALGRXAGC	Return Rx AGC value (LTE)
!DALGTXAGC	Return Tx AGC value and transmitter parameters (LTE)
!DAOFFLINE	Place modem offline
!DASBAND	Set the frequency band (UMTS/GSM)
!DASCHAN	Set the modem channel (frequency) (UMTS/GSM)
!DASLNAGAIN	Set the LNA (Low Noise Amplifier) gain state
!DASPDM	Set the PDM (Pulse Duration Modulation) value
!DASTXOFF	Turn off the Tx PA (Power Amplifier)
!DASTXON	Turn on the Tx PA (Power Amplifier)
!DAWGAVGAGC	Return averaged RX AGC value (WCDMA)
!DAWGRXAGC	Return the Rx AGC (Automatic Gain Control) value (UMTS)
!DAWINFO	Return WCDMA mode RF information
!DAWSCONFIGRX	Set the UMTS receiver to factory calibration settings

Table C-4: Extended AT commands

Command	Description
!DAWSPARANGE	Set the PA range state machine (UMTS)
!DAWSCHAINTCM	Place receive chain in test call mode (WCDMA)
!DAWSSCHAIN	Enable secondary receive chain (WCDMA)
!DAWSTXCW	Set the waveform used by the transmitter (UMTS)
!DAWSTXPWR	Set desired Tx power level (WCDMA)
!OSDSM	Display memory usage for DSM (Distributed Shared Memory) buffer pools

»» D: Packaging

D

Sierra Wireless AirPrime Mini Cards are shipped in sealed boxes. The standard packaging (see [Figure 4-1](#)), contains a single tray with a capacity of 100 modules. (Note that some SKUs may have custom packaging—contact Sierra Wireless for SKU-specific details.)

In the standard packaging, Mini Cards are inserted, system connector first, into the bottom portion (T1) of a two-part tray, all facing the same direction. This allows the top edge of each Mini Card to contact the top of the triangular features in the top portion (T2) of the tray (see Detail A).

The top and bottom portions of the tray snap together at the four connection points.

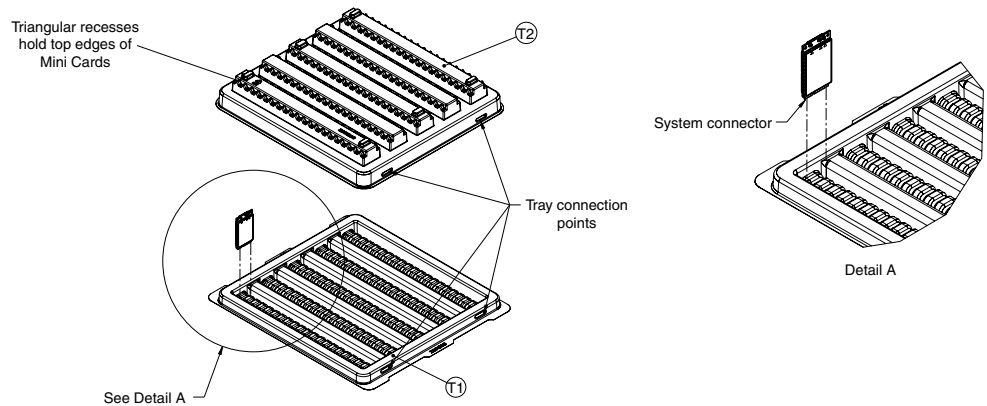

Figure 4-1: Device placement in module tray

The tray is placed in a manufacturing box (T2 at the top), sealed with a security tape (P1), and a manufacturing label is placed on the bottom-right corner, above the security tape. (See [Figure 4-2](#).)

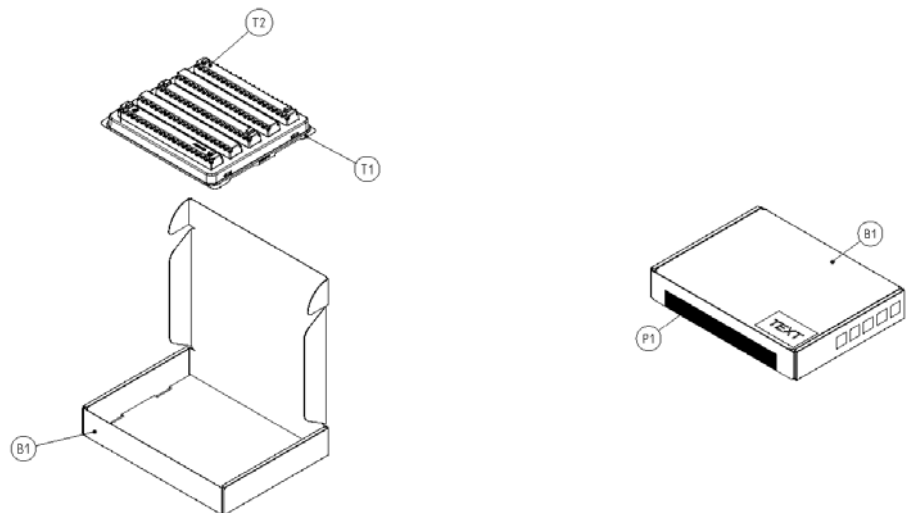

Figure 4-2: Shipping package

Sierra Wireless documents

The Sierra Wireless documents listed below are available from www.sierrawireless.com. For additional documents describing embedded module design, usage, and integration issues, contact your Sierra Wireless account representative.

Command documents

- [1] AT Command Set for User Equipment (UE) (Release 6)
(Doc# 3GPP TS 27.007)
- [2] AirPrime MiniCard MC73xx/MC8805 AT Command Reference
(Doc# 4114486)

Other Sierra documents

- [3] PCI Express Mini Card Dev Kit Quick Start Guide
(Doc# 2130705)
- [4] AirCard/AirPrime USB Driver Developer's Guide (Doc# 2130634)

Industry/other documents

The following non-Sierra Wireless references are not included in your documentation package:

- [5] CDMA 1x Standard (CDMA 200 Series Release A (2000))
(Doc# TIA/EIA/IS-2000 Series, Release A)
- [6] FCC Regulations - Part 15 - Radio Frequency Devices
- [7] IEC-61000-4-2 level 3
- [8] IEC-61000-4-2 level (Electrostatic Discharge Immunity Test)
- [9] Mobile Station (MS) Conformance Specification; Part 4:
Subscriber Interface Module (Doc# 3GPP TS 11.10-4)
- [10] PCI Express Mini Card Electromechanical Specification Revision
1.2
- [11] Universal Serial Bus Specification, Rev 2.0
- [12] JESD22-A114-B
- [13] JESD22-C101

LTE

LTE (Long Term Evolution) is a 4th-generation wireless standard. The [3GPP](#) Release 8 specification outlines the features and requirements.

Key features include.

- Peak data rate:
 - 100 Mbps DL within 20 MHz bandwidth (Peak DL data rate in 10 MHz bandwidth: 70 Mbps (approx.) for Cat 3 device)
 - 50 Mbps UL within 20 MHz bandwidth

Actual throughput depends on the network configuration, bandwidth assigned to the UE, the number of users, and RF signal conditions.

- Up to 200 active users in a cell (5 MHz)
- Less than 5 ms user-plane latency
- Supported bandwidths: 1.4/3/5/10/15/20 MHz (See [Table 4-2 on page 48](#) for band-specific support.)
- Spectrum flexibility: 1.4–20 MHz (3–20 MHz in future F/W release)
- Enhanced support for end-to-end [QOS](#)
- Frequency Division Duplexing (FDD)
- Physical layer uses:
 - [DL](#): OFDMA (Orthogonal Frequency Division Multiple Access). Modulation: QPSK, [16QAM](#), and 64QAM
 - [UL](#): Single Carrier FDMA (single carrier modulation and orthogonal frequency multiplexing) Modulation: QPSK and 16QAM
- MIMO (Multi-Input Multi-Output) antenna support

CDMA

1xEV-DO

1xEV-DO is backwards compatible to both [1X](#) and [IS-95A/B](#) standards. However, 1xEV-DO represents an evolutionary enhancement, specifically designed and optimized for high-speed wireless data access. This was driven by fundamental differences between voice and data traffic characteristics.

eHRPD (Enhanced High Rate Packet Data) is an enhancement of 1xEV-DO that enables LTE to CDMA handover.

To optimize for data, there are some fundamental characteristics and differences between 1X and 1xEV-DO, including:

- The network has dedicated spectrum (1.25 MHz) for data traffic using 1xEV-DO standard, so resources don't compete with 1X data/voice (hybrid mode used to monitor 1X carriers)
- BTS always transmits at maximum available power
- Each user receives data from only one base station at a time (no forward link soft handoff)
- 1xEV-DO lets each user use 100% of available resources, while dynamically allocating time resources among users for maximum efficiency
- 1xEV-DO uses time-division multiplexing of users on forward link (slots assigned for [packet](#) transmission)
- Forward link supports higher order modulation (QPSK, 8-PSK and 16-QAM)
- Reverse link (1xEV-DO Revision A) supports higher order modulation (8-PSK)
- Mobile supports dynamic channel estimation using measured [S/N](#) to set the highest rate it can decode (uses Data Rate Control channel to communicate to network access point)
- Mobiles can support Rx diversity for S/N enhancements particularly in multi-path/fading environments

1X and IS-95A

The type of data connection made at any given time depends on the services available from the carrier in the given coverage area. If 1X packet services are not available, the modem connects using circuit-switched data over [IS-95A](#) technology. The modem automatically selects the fastest connection mode available when a data call is connecting.

When [roaming](#), the modem **does not** automatically change connection modes. If the modem connects using 1X and then roams outside of the packet service area, the connection is dropped. To resume data communication, a new connection using IS-95A has to be created. Similarly, an IS-95A call established in one area does not automatically transition to 1X when the unit enters the 3G coverage area.

UMTS

The Universal Mobile Telecommunications System (UMTS) specification is the 3G mobile systems standard based on an evolution of GSM core network components. High-speed 3G systems implementing the UMTS standard enable improved performance for wireless data applications, delivery of enhanced multimedia content, and improved network capacity to support additional subscribers.

HSPA

HSPA is a third generation (3G) evolution of WCDMA that combines two extensions to UMTS—HSDPA (High Speed Downlink Packet Access) and HSUPA (High Speed Uplink Packet Access).

HSPA+

HSPA+ is an enhanced version of HSPA (High Speed Packet Access), as defined by the 3rd Generation Partnership Project (3GPP) Release 7 UMTS Specification for Mobile Terminated Equipment. Using improved modulation schemes and refined data communication protocols, HSPA+ permits increased uplink and downlink data rates.

DC-HSPA+

Dual-Carrier HSPA+ is an enhanced version of HSPA+, as defined by the 3GPP Release 8 UMTS Specification for Mobile Terminated Equipment. DC-HSPA+ uses paired spectrum allocations to double the bandwidth available and, therefore, double downlink data rates.

GPRS / EGPRS

GPRS and EGPRS are 2G wireless technologies providing end-to-end [packet](#) data services through reuse of existing GSM infrastructure.

Note: The network controls slot assignments based on current network loads and the bandwidth required by the mobile device - users cannot change slot assignments.

GPRS / EGPRS packet data rates are determined by the number of timeslots available for downlink (Rx) and uplink (Tx), and the coding scheme used for any given transmission.

The MC7354 supports:

- GPRS—Multislot class 10 (no backoff)—Four Rx slots (maximum), two Tx slots(maximum), five active slots total

- EGPRS—Multislot class 12 (with backoff. See [Table F-1 on page 104](#))—Four Rx slots (maximum), four Tx slots (maximum), five active slots total
- All standardized coding schemes (GMSK—CS 1 to CS 4, EDGE—MCS1 to MCS9)

Table F-1: EGPRS power backoff

Power class	Mode	Band	Coding scheme	Modulation	Power Backoff (dB)			
					1 Time slot	2 Time Slots	3 Time Slots	4 Time Slots
12	EGPRS	GSM850	MCS1–MCS4	GMSK	0	0	3.5	5.5
		GSM900						
		GSM850	MCS5–MCS9	8PSK	0	0	0	0
		GSM900						
		GSM1800	MCS1–MCS4	GMSK	0	0	2.5	3.5
		GSM1900						
		GSM1800	MCS5–MCS9	8PSK	0	0	0	0
		GSM1900						

»» G: Acronyms

Table G-1: Acronyms and definitions

Acronym or term	Definition
1xEV-DO	Single Carrier (1X) EVolution – Data Only. A high-speed standard for cellular packet data communications. Supports Internet connections with data rates up to 3.1 Mbps (downlink from the network) and 1.8 Mbps (uplink to the network). Average data rates are roughly: for Rev. A: 600 1300 kbps (downlink from the network) and 300 400 kbps (uplink to the network); for Rev. 0: 400 700 kbps (downlink from the network) and 40 80 kbps (uplink to the network). Actual speed depends on the network conditions. Compare to 1X .
1X	Single Carrier (1X) Radio Transmission Technology. A high-speed standard for cellular packet data communications. Supports Internet connections with data rates up to 153 kbps (simultaneously in each direction—downlink and uplink). Actual speed depends on the network conditions. Compare to 1xEV-DO .
3GPP	3rd Generation Partnership Project
8PSK	Octagonal Phase Shift Keying
AGC	Automatic Gain Control
A-GPS	Assisted GPS
API	Application Programming Interface
BER	Bit Error Rate—A measure of receive sensitivity
BLER	Block Error Rate
bluetooth	Wireless protocol for data exchange over short distances
CAIT	CDMA Air Interface Tool
CDG	CDMA Development Group—a consortium of companies that develop and promote the products and services for CDMA wireless systems.
CDMA	Code Division Multiple Access. A wideband spread spectrum technique used in digital cellular, personal communications services, and other wireless networks. Wide channels (1.25 MHz) are obtained through spread spectrum transmissions, thus allowing many active users to share the same channel. Each user is assigned a unique digital code, which differentiates the individual conversations on the same channel.
CQI	Channel Quality Indication
COM	Communication port
CS	Circuit-switched
CW	Continuous waveform

Table G-1: Acronyms and definitions (Continued)

Acronym or term	Definition
dB	Decibel = $10 \times \log_{10} (P1/P2)$ <i>P1 is calculated power; P2 is reference power</i> Decibel = $20 \times \log_{10} (V1/V2)$ <i>V1 is calculated voltage, V2 is reference voltage</i>
dBm	A logarithmic (base 10) measure of relative power (dB for decibels); relative to milliwatts (m). A dBm value will be 30 units (1000 times) larger (less negative) than a dBW value, because of the difference in scale (milliwatts vs. watts).
DC-HSPA+	Dual Carrier HSPA+
DCS	Digital Cellular System A cellular communication infrastructure that uses the 1.8 GHz radio spectrum.
DL	Downlink (network to mobile)
DUN	Dial-Up Networking
DRX	Discontinuous Reception
DSM	Distributed Shared Memory
DUT	Device Under Test
EDGE	Enhanced Data rates for GSM Evolution
eHRPD	Evolved High Rate Packet Data—Enhances traditional 1xEV-DO to enable LTE to CDMA handover.
EIRP	Effective (or Equivalent) Isotropic Radiated Power
EMC	Electromagnetic Compatibility
EMI	Electromagnetic Interference
ERP	Effective Radiated Power
ESD	Electrostatic Discharge
FCC	Federal Communications Commission The U.S. federal agency that is responsible for interstate and foreign communications. The FCC regulates commercial and private radio spectrum management, sets rates for communications services, determines standards for equipment, and controls broadcast licensing. Consult www.fcc.gov .
FDMA	Frequency Division Multiple Access
FER	Frame Error Rate—A measure of receive sensitivity.
firmware	Software stored in ROM or EEPROM; essential programs that remain even when the system is turned off. Firmware is easier to change than hardware but more permanent than software stored on disk.
FOTA	Firmware Over The Air—Technology used to download firmware upgrades directly from the service provider, over the air.
FOV	Field Of View

Table G-1: Acronyms and definitions (Continued)

Acronym or term	Definition
FSN	Factory Serial Number—A unique serial number assigned to the mini card during manufacturing.
GCF	Global Certification Forum
GLONASS	Global Navigation Satellite System—A Russian system that uses a series of 24 satellites in middle circular orbit to provide navigational data.
GMSK	Gaussian Minimum Shift Keying modulation
GNSS	Global Navigation Satellite Systems (GPS plus GLONASS)
GPRS	General Packet Radio Service
GPS	Global Positioning System An American system that uses a series of 24 satellites in middle circular orbit to provide navigational data.
GSM	Global System for Mobile Communications
Host	The device into which an embedded module is integrated
HSDPA	High Speed Downlink Packet Access
HSPA+	Enhanced HSPA, as defined in 3GPP Release 7 and beyond
HSUPA	High Speed Uplink Packet Access
Hz	Hertz = 1 cycle/second
IC	Industry Canada
IF	Intermediate Frequency
IMEI	International Mobile Equipment Identity
IMS	IP Multimedia Subsystem—Architectural framework for delivering IP multimedia services.
inrush current	Peak current drawn when a device is connected or powered on
inter-RAT	Radio Access Technology
IOT	Interoperability Testing
IS	Interim Standard. After receiving industry consensus, the TIA forwards the standard to ANSI for approval.
IS-2000	3G radio standards for voice and data (CDMA only)
IS-95	2G radio standards targeted for voice (cdmaONE)
LED	Light Emitting Diode. A semiconductor diode that emits visible or infrared light.
LHCP	Left-Hand Circular Polarized
LNA	Low Noise Amplifier

Table G-1: Acronyms and definitions (Continued)

Acronym or term	Definition
LPM	Low Power Mode
LPT	Line Print Terminal
LTE	Long Term Evolution—a high-performance air interface for cellular mobile communication systems.
MCS	Modulation and Coding Scheme
MHz	Megahertz = 10e6 Hz
MEID	Mobile Equipment Identifier—The unique second-generation serial number assigned to the minicard for use on the wireless network.
MIMO	Multiple Input Multiple Output—wireless antenna technology that uses multiple antennas at both transmitter and receiver side. This improves performance.
NAS/AS	Network Access Server
NC	No Connect
NIC	Network Interface Card
NMEA	National Marine Electronics Association
OEM	Original Equipment Manufacturer—a company that manufactures a product and sells it to a reseller.
OFDMA	Orthogonal Frequency Division Multiple Access
OMA DM	Open Mobile Alliance Device Management—A device management protocol.
OTA	'Over the air' (or radiated through the antenna)
PA	Power Amplifier
packet	A short, fixed-length block of data, including a header, that is transmitted as a unit in a communications network.
PCB	Printed Circuit Board
PCS	Personal Communication System A cellular communication infrastructure that uses the 1.9 GHz radio spectrum.
PDN	Packet Data Network
PMI	Pre-coding Matrix Index
PSS	Primary synchronisation signal
PST	Product Support Tools
PTCRB	PCS Type Certification Review Board
QAM	Quadrature Amplitude Modulation. This form of modulation uses amplitude, frequency, and phase to transfer data on the carrier wave.
QMI	Qualcomm MSM/Modem Interface

Table G-1: Acronyms and definitions (Continued)

Acronym or term	Definition
QOS	Quality of Service
QPSK	Quadrature Phase-Shift Keying
QPST	Qualcomm Product Support Tools
RAT	Radio Access Technology
RF	Radio Frequency
RI	Ring Indicator
roaming	A cellular subscriber is in an area where service is obtained from a cellular service provider that is not the subscriber's provider.
RSE	Radiated Spurious Emissions
RSSI	Received Signal Strength Indication
SDK	Software Development Kit
SED	Smart Error Detection
Sensitivity (Audio)	Measure of lowest power signal that the receiver can measure.
Sensitivity (RF)	Measure of lowest power signal at the receiver input that can provide a prescribed BER/BLER/SNR value at the receiver output.
SG	An LTE signaling interface for SMS ("SMS over SGs")
SIB	System Information Block
SIM	Subscriber Identity Module. Also referred to as USIM or UICC.
SIMO	Single Input Multiple Output—smart antenna technology that uses a single antenna at the transmitter side and multiple antennas at the receiver side. This improves performance and security.
SISO	Single Input Single Output—antenna technology that uses a single antenna at both the transmitter side and the receiver side.
SKU	Stock Keeping Unit—identifies an inventory item: a unique code, consisting of numbers or letters and numbers, assigned to a product by a retailer for purposes of identification and inventory control.
SMS	Short Message Service. A feature that allows users of a wireless device on a wireless network to receive or transmit short electronic alphanumeric messages (up to 160 characters, depending on the service provider).
S/N	Signal-to-noise (ratio)
SNR	Signal-to-Noise Ratio
SOF	Start of Frame—A USB function.
SSS	Secondary synchronisation signal.

Table G-1: Acronyms and definitions (Continued)

Acronym or term	Definition
SUPL	Secure User Plane Location
TIA/EIA	Telecommunications Industry Association / Electronics Industry Association. A standards setting trade organization, whose members provide communications and information technology products, systems, distribution services and professional services in the United States and around the world. Consult www.tiaonline.org .
TIS	Total Isotropic Sensitivity
TRP	Total Radiated Power
UDK	Universal Development Kit (for PCI Express Mini Cards)
UE	User Equipment
UICC	Universal Integrated Circuit Card (Also referred to as a SIM card.)
UL	Uplink (mobile to network)
UMTS	Universal Mobile Telecommunications System
USB	Universal Serial Bus
USIM	Universal Subscriber Identity Module (UMTS)
VCC	Supply voltage
VSWR	Voltage Standing Wave Ratio
WAN	Wide Area Network
WCDMA	Wideband Code Division Multiple Access (also referred to as UMTS)
WLAN	Wireless Local Area Network
ZIF	Zero Intermediate Frequency

Index

Numerics

- 1X
 - overview, [102](#)
- 1xEV-DO
 - overview, [101](#)
- 3D gain, average
 - gain
 - 3D average (GNSS), [77](#)
- 3GPP compliance
 - GSM/GPRS/EDGE, [23](#)
 - LTE, [23](#)
 - UMTS, [23](#)

A

- acceptance tests, [81](#)
- accessories, [21](#)
- accuracy (GNSS), [52](#)
- acquisition time (GNSS), [52](#)
- acronyms and definitions, [105–110](#)
- A-GNSS, [20](#)
- A-GPS, [20](#)
- antenna
 - connection considerations, [43](#)
 - connectors, [25](#)
 - custom, design, [44](#)
 - diversity antenna, disabling, [44](#)
 - GNSS, specifications, recommended, [77](#)
 - limit, matching coaxial connections, [43](#)
 - location, considerations, [44](#)
 - matching, considerations, [44](#)
 - maximum cable loss, [43](#)
 - routing, [44](#)
 - specification, [75–78](#)
 - specifications, recommended, [75](#)
 - testing, [77](#)
- antennas
 - design checklist, [79](#)
- API, [63](#)
- application interface features, [18](#)
- approvals, regulatory and industry, [71](#)
- AT commands, [94](#)
- averaged call mode DC power consumption, [56](#)
- averaged standby DC power consumption, [55](#)

B

- bands supported, RF
 - summary, [17](#)
 - CDMA, [49](#)
 - GSM, [49](#)
 - LTE, [48](#)
 - WCDMA, [48](#)

- bearers, dedicated, [20](#)
- BER (Bit Error Rate), [47](#)
- bit error rate (BER)
 - measure of sensitivity, [47](#)
- block diagram
 - expanded RF, [27](#)
 - system, [26](#)
- bottom view, [66](#)

C

- cable loss
 - antenna, maximum, [43](#)
- CAIT support, [63](#)
- capacitors
 - with SIM, [35](#)
 - with XIM_DATA / XIM_CLK, [35](#)
- carrier/operator testing, [94](#)
- CDMA
 - bands supported, [17](#)
 - overview, [101](#)
 - frequency band support, [49](#)
 - TIA/EIA/IS compliance, [23](#)
- cell selection, [19](#)
- certification tests, [82](#)
- checklist, design, [79](#)
- communications, host to modem
 - design checklist, [80](#)
- conducted Tx power tolerances, [51](#)
- connection
 - grounding, [45](#)
- connectors, [43](#)
- connectors, required
 - host-module, [21](#)
- control interface, [36](#)
- CQI, [19](#)

D

- DC power consumption
 - averaged call mode, [56](#)
 - averaged standby, [55](#)
- DC-HSPA+
 - overview, [103](#)
- desense. See RF
- design checklist
 - antennas, [79](#)
 - component placement, [79](#)
 - EMI/ESD, [79](#)
 - host/modem communications, [80](#)
 - power, [79](#)
 - thermal, [80](#)
- detach procedure, [20](#)

- Development Kit contents, [21](#)
- digital interface, [41](#)
- dimensioned view, [67](#)
- dimensions, [66](#), [67](#)
- diversity antenna
 - disabling, [44](#)
- diversity connector, location, [43](#)
- drop specifications, [65](#)

E

- EDGE
 - overview, [103](#)
 - bands supported, [18](#)
 - connector, required, [21](#)
- electrical specifications, [25](#)
- electrostatic discharge specifications, [66](#)
- electrostatic discharge. See ESD
- envelope correlation coefficient, [76](#)
- environmental specifications, [65–68](#)
- ESD
 - design checklist, [79](#)
 - protection requirements, [68](#)
- ESD specifications, [66](#)
- EVDO
 - overview, [101](#)
- expanded RF block diagram, [27](#)

F

- FER (Frame Error Rate), [47](#)
- field of view, [77](#)
- filtering, RF desense, [46](#)
- form factor, [66](#)
- FOV, [77](#)
- frame error rate (FER)
 - measure of sensitivity, [47](#)
- free space average gain, [77](#)
- frequencies supported, [47](#)
- frequency band support
 - CDMA, [49](#)
 - GSM, [49](#)
 - LTE, [48](#)
 - WCDMA, [48](#)

G

- gain
 - GNSS, [77](#)
 - maximum, [72](#), [76](#)
 - mean effective, [76](#)
 - mean effective imbalance, [76](#)
- GERAN compliance
 - GSM/GPRS/EDGE, [23](#)

- GNSS
 - antenna specifications, recommended, [77](#)
 - connector location, [43](#)
 - features supported, [20](#)
 - specifications, [52](#)
- GPRS
 - overview, [103](#)
 - bands supported, [18](#)
- ground specifications, [32](#)
- grounding
 - connection considerations, [45](#)
- GSM
 - bands supported, [18](#)
 - frequency band support, [49](#)
- GSM/GPRS/EDGE
 - 3GPP compliance, [23](#)
 - GERAN compliance, [23](#)

H

- host interface
 - pin assignments, [27](#)
- HSDPA
 - bands supported, [17](#)
- HSPA
 - overview, [103](#)
- HSPA+
 - overview, [103](#)
 - bands supported, [17](#)
- HSUPA
 - bands supported, [17](#)
- humidity specifications, [65](#)

I

- I/O connector location, [43](#)
- I/O rise time requirements, [35](#)
- impedance
 - module–antenna, [44](#)
 - SIM, [35](#)
- industry approvals, [71](#)
- integration requirements, [22](#)
- interface
 - control interface, [36](#)
 - digital interface, [41](#)
 - feature summary, [18](#)
 - host, pin assignments, [27](#)
 - QMI, [63](#)
 - SIM, [33](#)
 - software, [63](#)
 - USB, [32](#)
- interference
 - device generated, [46](#)
 - host-generated, [46](#)
 - power supply noise, [61](#)
 - wireless devices, [45](#)
- Interoperability testing, [94](#)
- intra-LTE mobility, [20](#)

IOT testing, [94](#)
 iRAT, [20](#)
 IS-95A
 overview, [102](#)
 isolation, [76](#), [77](#)

L

labeling, [67](#)
 LED
 example, [38](#)
 LED output, [25](#), [36](#), [37](#)
 LTE
 3GPP compliance, [23](#)
 overview, [101](#)
 bands supported, [17](#)
 bandwidth support, [48](#)
 features, [19](#)
 frequency band support, [48](#)

M

mean effective gain, [76](#)
 mean effective gain imbalance, [76](#)
 mechanical specifications, [65–68](#)
 MIB, [19](#)
 MIMO support, [17](#)
 minicom
 downloading and installing, [86](#)
 module
 power states, [57–59](#)

N

NAS/AS security, [19](#)
 noise
 leakage, minimizing, [45](#)
 RF interference, power supply, [61](#)

O

OEM
 assistance with testing, [94](#)
 labeling, [68](#)
 operator/carrier testing, [94](#)
 ordering information, [21](#)

P

packaging, [97](#)
 paging procedures, [19](#)
 PCB
 multi-layer, shielding for RF desense, [46](#)
 PCM/I2S audio interface, [38](#)
 PDN connections, multiple, [20](#)
 pin assignments, host interface, [27](#)
 PMI, [19](#)

polarization, [77](#)
 position location, [20](#)
 power
 design checklist, [79](#)
 handling, [76](#)
 power-up timing, [59](#)
 ramp-up timing, [59](#)
 state machines, [58](#)
 states, module, [57–59](#)
 supply, RF interference, [61](#)
 supply, ripple limit, [61](#)
 transmit, waveform, [61](#)
 power consumption, DC
 averaged call mode, [56](#)
 averaged standby, [55](#)
 power specifications, [32](#)
 power tolerances, conducted Tx, [51](#)
 Product Support Tool, QUALCOMM (QPST), [63](#)
 Product Support Tool, Sierra Wireless (PST), [63](#)
 production tests, [83](#)
 PSS, [19](#)
 PST (Product Support Tool, Sierra Wireless), [63](#)

Q

QMI interface, [63](#)
 QPST (QUALCOMM Product Support Tool), [63](#)
 QUALCOMM Product Support Tool (QPST), [63](#)
 quality assurance tests, [93](#)
 QXDM support, [63](#)

R

radiated efficiency, total, [75](#)
 radiated sensitivity measurement, [47](#)
 radiated spurious emissions, [46](#)
 radiation patterns, [76](#)
 references, [99](#)
 regulatory approvals, [71](#)
 regulatory information, [71–74](#)
 FCC, [72](#)
 limitation of liability, [71](#)
 safety and hazards, [71](#)
 reset device, [38](#)
 resistors, external pull-up, [35](#)
 RF
 antenna cable loss, maximum, [43](#)
 antenna connection, considerations, [43](#)
 connectors, required, [21](#)
 desense
 device-generated, [46](#)
 harmonic energy, filtering, [46](#)
 mitigation suggestions, [46](#)
 shielding suggestions, [46](#)
 interference
 other devices, [46](#)
 power supply, [61](#)
 wireless devices, [45](#)

- RF bands supported
 - summary, 17
 - CDMA, 49
 - GSM, 49
 - LTE, 48
 - WCDMA, 48
- RF block diagram, expanded, 27
- RF connector location, 43
- RF specifications, 43–53
- RI, 19
- RSE, 46
- Rx sensitivity
 - conducted, 50, 51

S

- sales
 - ordering, 21
- SDKs available, 63
- SED
 - see Smart Error Detection
- See also GPS_DISABLE_N, 25
- See also W_DISABLE_N, 37
- sensitivity
 - conducted, RF parameter, 50, 51
 - defined, 47
 - radiated measurement, overview, 47
 - testing, overview, 47
- shielding
 - module, compliance, 43
 - reducing RF desense, 46
- shock specifications, 65
- SIB, 19
- signals, 36
 - SYSTEM_RESET_N, 38
 - W_DISABLE_N, 37
 - WAKE_N, 36
 - WLAN_LED_N, 37
- SIM
 - capacitor recommendations, 35
 - card contacts, 34
 - clock rate, 35
 - connector, required, 21
 - electrical specifications, 35
 - impedance, connectors, 35
 - interface, 33
 - interface diagram, 34
 - operation, 35
- Smart Error Detection
 - detecting module reset, 61
- SMS features, 20
- Snow 3G/AES security, 19
- software interface, 63
- specifications
 - electrical, 25
 - environmental specifications, 65–68
 - GNSS, 52
 - mechanical, 65–68
 - RF, 43–53

- SSS, 19
- standalone mode, concurrent, GNSS, 20
- standby DC power consumption, averaged, 55
- state machines, 58
- support
 - features, 20
 - testing assistance by Sierra Wireless, 94
 - tools, 63
- system acquisition, 19
- system block diagram, 26
- SYSTEM_RESET_N, 38

T

- temperature specifications, 65
- temperature, module. See thermal
- testing
 - overview, 81
 - acceptance tests, 81
 - assistance provided by Sierra Wireless, 94
 - certification tests, 82
 - equipment, suggested, 93
 - interoperability and operator/carrier testing, 94
 - manual functional test, suggested, 83
 - production tests, 83
 - quality assurance tests, 93
 - RF receive path, LTE, 91
 - suggestions, 81–96
- thermal
 - considerations, 68–69
 - design checklist, 80
 - dissipation, factors affecting, 68
 - dissipation, suggestions, 69
 - internal temperature, maximum, 69
 - testing, module, 69
- TIA/EIA/IS compliance
 - CDMA, 23
- timing
 - power ramp-up, 59
 - power-up, 59
- top view, 66
- transmit power waveform, 61
- Tx power tolerances, conducted, 51

U

- UDK, 21
- UMTS
 - 3GPP compliance, 23
 - overview, 102
 - bands supported, 17
- Universal Development Kit, 21
- USB
 - drivers, user-developed, 33
 - high / full speed throughput performance, 33
 - interface, 32

V

vibration specifications, [65](#)
VSWR, [75](#), [77](#)

W

W_DISABLE_N, [36](#), [37](#)
WAKE_N, [25](#), [36](#)
warranty, [20](#)

WCDMA

frequency band support, [48](#)
Wireless Disable, [25](#), [36](#)
Wireless Disable (GNSS), [25](#)
Wireless Disable (Main RF), [37](#)
WLAN_LED_N, [36](#), [37](#)

Z

ZIF (Zero Intermediate Frequency), [45](#)



SIERRA
WIRELESS®