



Product Technical Specification

EM759x

Important Notice

Information relating to this product and the application or design described herein is believed to be reliable, however such information is provided as a guide only and Semtech assumes no liability for any errors in this document, or for the application or design described herein.

Semtech reserves the right to make changes to the product or this document at any time without notice. Buyers should obtain the latest relevant information before placing orders and should verify that such information is current and complete. Semtech warrants performance of its products to the specifications applicable at the time of sale, and all sales are made in accordance with Semtech's standard terms and conditions of sale.

SEMTECH PRODUCTS ARE NOT DESIGNED, INTENDED, AUTHORIZED OR WARRANTED TO BE SUITABLE FOR USE IN LIFE-SUPPORT APPLICATIONS, DEVICES OR SYSTEMS, OR IN NUCLEAR APPLICATIONS IN WHICH THE FAILURE COULD BE REASONABLY EXPECTED TO RESULT IN PERSONAL INJURY, LOSS OF LIFE OR SEVERE PROPERTY OR ENVIRONMENTAL DAMAGE. INCLUSION OF SEMTECH PRODUCTS IN SUCH APPLICATIONS IS UNDERSTOOD TO BE UNDERTAKEN SOLELY AT THE CUSTOMER'S OWN RISK. Should a customer purchase or use Semtech products for any such unauthorized application, the customer shall indemnify and hold Semtech and its officers, employees, subsidiaries, affiliates, and distributors harmless against all claims, costs damages and attorney fees which could arise.

The Semtech name and logo are registered trademarks of the Semtech Corporation. All other trademarks and trade names mentioned may be marks and names of Semtech or their respective companies. Semtech reserves the right to make changes to, or discontinue any products described in this document without further notice. Semtech makes no warranty, representation or guarantee, express or implied, regarding the suitability of its products for any particular purpose. All rights reserved.

Wireless Communications

Due to the nature of wireless communications, transmission and reception of data can never be guaranteed. Data may be delayed, corrupted (i.e., have errors) or be totally lost. The Semtech product should not be used in situations where failure to transmit or receive data could result in damage of any kind to the user or any other party, including but not limited to personal injury, death, or loss of property. Semtech accepts no responsibility for damages of any kind resulting from delays or errors in data transmitted or received using the Semtech product, or for failure of the Semtech product to transmit or receive such data.

Warranty

Warranty information for AirLink products is available at www.sierrawireless.com/end-user-warranty.

Safety

Do not operate the Semtech product in areas where blasting is in progress, where explosive atmospheres may be present, near medical equipment, near life support equipment, or near any equipment which may be susceptible to any form of radio interference. In such areas, the Semtech product should be powered off.

Qualcomm licenses

Semtech’s cellular modules are sold subject to certain notices and restrictions regarding patent licenses from Qualcomm Incorporated. These notices and restrictions are available at www.sierrawireless.com/qualcomm-notices.

Sierra Wireless

Semtech Corporation acquired Sierra Wireless in January 2023. The Sierra Wireless brand is gradually being phased out. During the phase-out period, references to both “Semtech” and “Sierra Wireless” may appear in product documentation.

Contact Information

Sales information and technical support, including warranty and returns	Web: sierrawireless.com/company/contact-us/ Global toll-free number: 1-877-687-7795 6:00 am to 5:00 pm PST
Corporate and product information	Web: sierrawireless.com

Revision History

Revision number	Release date	Changes
1	Apr 2022	Document creation, preliminary release
2	Jul 2022	Updated Table 1-4, EM7595 Carrier Aggregation Downlink Combinations Updated Table 4-3, Typical Conducted Rx (Receive) Sensitivity — LTE Bands at 10 MHz BW Updated Table 4-4, Conducted Rx (Receive) Sensitivity — UMTS Bands Updated Table 4-5, Conducted Tx (Transmit) Power Tolerances Updated Table 4-6, GNSS Specifications Updated Table 5-1, Averaged Standby DC Power Consumption Updated Table 5-1, Averaged Standby DC Power Consumption Updated Table 5-2, Averaged Call Mode DC Power Consumption Updated Table 5-3, Miscellaneous DC Power Consumption Updated Table 5-5, Power State Transition Default Trigger Levels Updated Table 5-1, Voltage/Temperature Monitoring State Machines Updated Table 5-6, USB 2.0 Power-On/Off Timing Parameters (Single Enumeration) Updated Tx Power Control (removed !SARBACKOFF) Updated Support Tools Updated Figure 7-4, EM7595 Unit Product Marking Example — Laser-etched, Typical Representation Updated Thermal Considerations (supply voltage) Updated Table E-1, Thermal Testing — Suggested Worst Case Conditions

Revision number	Release date	Changes
3	Aug 2022	Updated Timing (Added Double Enumeration to Figure 5-2; Added Table 5-8, Table 5-9) Updated Table 5-6, Table 5-7 Updated Regulatory Compliance and Industry Certifications (Added MIC, RED, Table 8-1; Updated Table 8-2)
4	Sep 2022	Updated Conducted Tx (Transmit) Power Tolerances (LTE B39) Updated Table 5-6, Table 5-7, Table 5-8, Table 5-9 Added USB enumeration figures (Figure 5-3. Figure 5-3) Updated Reset Timing Corrected IC ID
5	Nov 2022	Updated Figure 3-5 and Table C-1 EMI/ESD entry Updated Figure 5-4 Corrected GNSS RF Receive Path Test (!DACGPSSTANDALONE value)
6	Jun 2023	Updated Modem Features (added Public Safety features (QCI values)) Updated Table 5-5 (temperature trigger values) Updated Thermal Considerations (maximum power dissipation, document references) Updated Table C-1 (Removed RmNet from Windows Driver support statement)
7	Aug 2023	Added EM7595 Moved carrier aggregation tables to Carrier Aggregations Updated Table 3-7 (updated RESET# description)
8	Oct 2023	Corrected typo in Table 3-1 (Corrected pin number for pin 64)
9	Dec 2023	Corrected gpsOneXTRA version (3.1) Updated Table 4-2 (removed inapplicable bands (B17, B46)) Updated Table 5-2 (replaced TBD entries with measured values, updated peak current) Updated Table 5-2 (updated Maximum current) Updated Reset Timing (removed Case 6 from list and Figure 5-5) Updated Figure 7-2 (updated front view with dimensional tolerances) Updated LTE RF Receive Path Test (corrected typo in !DARCONFIG command)
10	Mar 2024	Updated Figure 3-2 Updated Table 7-1 (updated Ambient temperature details; removed Relative humidity; added Humidity Test)
11	Apr 2025	New document format applied Removed chapter 2: Standards (content moved to 7: Regulatory Compliance and Industry Certifications) Updated Table 3-1, Supported Frequency Bands, by RAT (LTE/3G) (B42 Tx range adjustment for Canada; added LTE B106) Updated Table 3-2, LTE Bandwidth Support (added LTE B106) Updated Table 3-3, Typical Conducted Rx (Receive) Sensitivity — LTE Bands at 10 MHz BW (added LTE B106) Updated Table 3-5, Conducted Tx (Transmit) Power Tolerances (added LTE B106) Corrected Figure 4-5, Signal Timing (RESET#) (Figure position) Separated 7.1 Important Compliance Information for Canada and the United States into Important Compliance Information for Canada and Important Compliance Information for the United States (continued on next page)

Revision number	Release date	Changes
		(continued from previous page) Updated Table 7-1, ISED Antenna Gain and Collocated Radio Transmitter Specifications (adjusted B42 Tx range for Canada only) Updated Table 7-2, FCC Antenna Gain and Collocated Radio Transmitter Specifications (added LTE B106)

Contents

Important Notice	2
Wireless Communications.....	2
Warranty.....	2
Safety.....	2
Qualcomm licenses	3
Sierra Wireless	3
Contact Information	3
Revision History	3
Introduction	13
Supported RF bands	13
Mechanical Features.....	13
Host Interface Features.....	14
Modem Features	14
LTE Features	15
Short Message Service (SMS) Features.....	15
Position Location (GNSS).....	15
Supporting Documents.....	16
Accessories	16
Required Connectors.....	16
Integration Guidance.....	16
Security Considerations	17
Electrical Specifications	18
M.2 (Host) Interface Pin Assignments	21
Power Supply	27
USB Interface	28
Host-side Recommendation	29
USB Throughput Performance	29
SIM Interface	29
SIM Implementation.....	31
Control Interface (Signals)	32
WAKE_ON_WAN# — Wake Host	33
W_DISABLE# (Wireless Disable) and GPS_DISABLE# (GNSS Disable).....	34
Full_Card_Power_Off# and RESET#	35
WWAN_LED# — LED Output.....	36
Antenna Control	36

RF Specifications	37
RF Connections	37
Shielding	37
Antennas and Cabling	37
Choosing the Correct Antenna and Cabling	38
Designing Custom Antennas	38
Determining the Antenna's Location	38
Disabling the Diversity Antenna	38
Ground Connection	38
Interference and Sensitivity	39
Interference from Other Wireless Devices	39
Host-generated RF Interference	39
Device-generated RF Interference	39
Methods to Mitigate Decreased Rx Performance	39
Radiated Spurious Emissions (RSE)	40
Radiated Sensitivity Measurement	40
Sierra Wireless' Sensitivity Testing and Desensitization Investigation	40
Sensitivity vs. Frequency	40
Supported RATs	41
Supported Bands	41
Conducted Rx Sensitivity/Tx Power	43
GNSS Specifications	45
Power	47
Power Consumption	47
Module Power States	49
Power State Transitions	50
Power Interface	51
Power Ramp-up	51
Timing	52
Power On/Off Timing for USB Port	52
USB Enumeration	53
Reset Timing	54
Required Shutdown Sequence	55
Power Supply Noise	56
SED (Smart Error Detection)	56
Tx Power Control	56
Software	57
Support Tools	57
Host Interface	57

Mechanical and Environmental Specifications	58
Device Views	59
Product Marking.....	60
Electrostatic Discharge (ESD).....	61
Thermal Considerations.....	61
Module Integration Testing.....	62
Regulatory Compliance and Industry Certifications	63
Regulatory Compliance.....	63
Important Compliance Information for Canada.....	63
Important Compliance Information for the United States.....	64
Industry Certifications	66
Antenna Specification	67
Recommended Main/Diversity Antenna Specifications	67
Recommended GNSS Antenna Specifications.....	68
Antenna Tests.....	69
Carrier Aggregations	70
Design Checklist	73
Testing	75
AT Command Entry Timing Requirement.....	75
Acceptance Testing	75
Acceptance Test Requirements	75
Certification Testing	75
Production Testing.....	76
Functional Production Test.....	76
Suggested Production Tests	77
Production Test Procedure.....	77
UMTS (WCDMA) RF Transmission Path Test	78
LTE RF Transmission Path Test	80
UMTS (WCDMA) RF Receive Path Test.....	82
LTE RF Receive Path Test.....	83
GNSS RF Receive Path Test.....	86
Quality Assurance Testing.....	86
Suggested Testing Equipment.....	87
Testing Assistance Provided by Sierra Wireless.....	87
IOT/Operator Testing	87
Extended AT Commands for Testing	87

Thermal Testing	89
Worst Case Testing	89
Thermal Testing Process	89
Packaging	91
References	92
Sierra Wireless Documents	92
Industry/Other Documents	92
Abbreviations	93

List of Figures

Figure 2-1: System Block Diagram	19
Figure 2-2: Expanded RF (Transmit) Block Diagram.....	20
Figure 2-3: Expanded RF (Receive/GNSS) Block Diagram	21
Figure 2-4: Recommended Capacitor Placement for USB 3.0 Signals	29
Figure 2-5: SIM Application Interface (applies to both SIM interfaces).....	31
Figure 2-6: SIM Card Contacts (Contact View).....	31
Figure 2-7: Recommended WAKE_ON_WAN# Connection	33
Figure 2-8: Recommended Wireless Disable Connection.....	34
Figure 2-9: Recommended LED Connection.....	36
Figure 3-1: Module Connectors	37
Figure 4-1: Voltage/Temperature Monitoring State Machines	51
Figure 4-2: Signal Timing (Full_Card_Power_Off#, and USB Enumeration)	52
Figure 4-3: USB 2.0 Double Enumeration— Example Sequence Waveform	54
Figure 4-4: USB 3.0 Double Enumeration— Example Sequence Waveform	54
Figure 4-5: Signal Timing (RESET#).....	55
Figure 6-1: Top View	59
Figure 6-2: Dimensioned View	59
Figure 6-3: EM7590 Unit Product Marking Example— Laser-etched, Typical Representation .	60
Figure 6-4: EM7595 Unit Product Marking Example— Laser-etched, Typical Representation .	60
Figure 6-5: Shield Locations (Top View).....	61
Figure 6-6: Copper Pad Location on Bottom Side of Module.....	62
Figure 0-1: Device Placement in Module Tray	91
Figure 0-2: Shipping Package	91

List of Tables

Table 1-1: Supported RF Bands	13
Table 1-2: Required Host-Module Connectors	16
Table 2-1: Host Interface (75-pin) Connections — Module View	22
Table 2-2: Power and Ground Specifications	27
Table 2-3: USB Interface.	28
Table 2-4: SIM Interface Signals.	30
Table 2-5: Module Control Signals.	33
Table 2-6: W_DISABLE#/GPS_DISABLE# Usage.	34
Table 2-7: Full_Card_Power_Off# and RESET# Usage	35
Table 2-8: Antenna Control Signals.	36
Table 3-1: Supported Frequency Bands, by RAT (LTE/3G)	41
Table 3-2: LTE Bandwidth Support	42
Table 3-3: Typical Conducted Rx (Receive) Sensitivity — LTE Bands at 10 MHz BW	43
Table 3-4: Conducted Rx (Receive) Sensitivity — UMTS Bands	45
Table 3-5: Conducted Tx (Transmit) Power Tolerances.	45
Table 3-6: GNSS Specifications.	45
Table 4-1: Averaged Standby DC Power Consumption	47
Table 4-2: Averaged Call Mode DC Power Consumption	48
Table 4-4: Module Power States	49
Table 4-3: Miscellaneous DC Power Consumption.	49
Table 4-5: Power State Transition Default Trigger Levels	50
Table 4-6: USB 2.0 Power-On/Off Timing Parameters (Single Enumeration)	52
Table 4-7: USB 3.0 Power-On/Off Timing Parameters (Single Enumeration)	53
Table 4-8: USB 2.0 Power-On/Off Timing Parameters (Double Enumeration)	53
Table 4-9: USB 3.0 Power-On/Off Timing Parameters (Double Enumeration)	53
Table 4-10: Dynamic Power Control of SAR Backoff State	56
Table 6-1: Mechanical and Environmental Specifications	58
Table 7-1: ISED Antenna Gain and Collocated Radio Transmitter Specifications	63
Table 7-2: FCC Antenna Gain and Collocated Radio Transmitter Specifications	65
Table 7-3: Standards Compliance	66

Table A-1: Antenna Requirements	67
Table A-2: GNSS Antenna Requirements	68
Table B-1: EM759X Carrier Aggregation (2CC) Downlink Combinations	70
Table B-2: EM7595 Carrier Aggregation (3CC) Downlink Combinations	70
Table B-3: EM759X Carrier Aggregation Uplink Combinations.....	72
Table C-1: Hardware Integration Design Considerations	73
Table D-1: Test Settings — UMTS Transmission Path.....	78
Table D-2: Test Settings — LTE Transmission Path.....	80
Table D-3: Test Settings — UMTS Receive Path	82
Table D-4: Test Settings — LTE Receive Path	83
Table D-5: Extended AT Commands	87
Table E-1: Thermal Testing — Suggested Worst Case Conditions.....	89
Table H-1: Abbreviations and Definitions	93

1: Introduction

Sierra Wireless EM759X Embedded Modules (EM7590, EM7595) are FirstNet-ready (B14 LTE) M.2 modules that provide LTE, UMTS and GNSS connectivity for notebook, ultrabook, tablet computers, and M2M applications over several radio frequency bands.

Note: In this document:

- EM759X refers to EM7590 and EM7595.

1.1 Supported RF bands

The modules, based on Qualcomm's SDX12 baseband processor, support data operation on LTE and UMTS networks over the bands described in [Table 1-1](#), with LTE carrier aggregation (CA) as described in [Carrier Aggregations](#).

Table 1-1: Supported RF Bands

RAT	Bands																														
	1	2	3	4	5	6	7	8	9	12	13	14	18	19	20	25	26	28	29	32	38	39	40	41	42	43	48	66	71	106 ^a	
LTE ^b	F	F	F	F	F	—	F	F	—	F	F	F	F	F	F	F	F	F	F ^c	F ^c	T	T	T	T	T	T	T	T	F	F	F
UMTS ^d	Y	Y	—	Y	Y	Y	—	Y	Y	—	—	—	—	Y	—	—	—	—	—	—	—	—	—	—	—	—	—	—	—	—	—
GNSS	<ul style="list-style-type: none"> GPS: 1575.42 MHz GLONASS: 1602 MHz BeiDou: 1561.098 MHz Galileo: 1575.42 MHz QZSS: 1575.42 MHz 																														

a. LTE B106 availability is SKU-specific. For details, contact your Semtech account representative.

b. (LTE) Downlink MIMO support (2x2; 4x2) F=FDD; T=TDD

Data rates:

EM7590: Downlink (Cat 13 with 2CA, 256QAM=400 Mbps), Uplink (Cat 13 with 2CA contiguous, 64QAM=150 Mbps)

EM7595: Downlink (Cat 12 with 3CA, 256QAM=600 Mbps), Uplink (Cat 13 with 2CA contiguous, 64QAM=150 Mbps)

c. Downlink only

d. UMTS (DC-HSPA+, HSPA+, HSPA, UMTS) Diversity support

Data rates: Downlink (Cat 24, up to 42 Mbps), Uplink (Cat 6, up to 5.76 Mbps)

1.2 Mechanical Features

- M.2 form factor:
 - WWAN Type 3042-S3-B (in WWAN — USB3 Port Configuration 2) with length of 42 mm, as specified in [\[5\] PCI Express NGFF \(M.2\) Specification Revision 1.0](#).
 - Conforms to M.2 form factor width specification. For complete dimensions, see [Figure 6-2](#).
 - Input voltage per M.2 specification

Note: Any variations from the M.2 specification are detailed in this document.

- Ambient operating temperature range with appropriate heatsinking:
 - Class A (3GPP compliant): -30°C to +70°C
 - Class B (operational, non-3GPP compliant): -40°C to +85°C (reduced operating parameters required)

Important: *The internal module temperature (reported by AT!PCTEMP?) must be kept below 100°C. For best performance, the internal module temperature should be kept below 85°C. Proper mounting, heat sinks, and active cooling may be required, depending on the integrated application.*

1.3 Host Interface Features

- USB interface (QMI) for Linux and Android
- MBIM for Windows 10, Windows 11, and Linux
- AT command interface ([4] *AT Command Set for User Equipment (UE) (Release 6) (Doc# 3GPP TS 27.007)*), plus proprietary extended AT commands in [1] *Sierra Wireless EM759X AT Command Reference (Doc# 41114426)*
- Support for active antenna control via dedicated antenna control signals (ANTCTLO:3)
- Dynamic power reduction support via software and dedicated GPIO (DPR)
- OMA LwM2M (Lightweight M2M)
- FOTA (Firmware Over The Air)

Note: OMA LwM2M and FOTA support is operator-dependent.

1.4 Modem Features

- 4G LTE, 3G (DC-HSPA+ / HSPA+ / HSPA / UMTS (WCDMA)) operation
- Multiple (up to 16) cellular packet data profiles
- Traditional modem COM port support for AT commands
- USB suspend / resume
- Sleep mode for minimum idle power draw
- SIM application tool kit with proactive SIM commands
- Enhanced Operator Name String (EONS)
- Mobile-originated PDP context activation / deactivation
- QoS QCI
- Static and Dynamic IP address. The network may assign a fixed IP address or dynamically assign one using DHCP (Dynamic Host Configuration Protocol).
- PAP and CHAP support
- PDP context type (IPv4, IPv6, or IPv4v6)
- RFC1144 TCP/IP header compression
- Secure boot (see [Security Considerations](#))
- Public Safety 3GPP features (3GPP Release 12) per 3GPP TS 23.203 and 3GPP TS 29.212 — QCI values: 65, 66, 69, 70

1.5 LTE Features

- Carrier aggregation

Download / Upload	EM7590	EM7595
DL LTE-FDD	40 MHz	60 MHz
DL LTE-TDD	40 MHz	60 MHz
UL LTE	40 MHz intraband contiguous	

- LTE Advanced receivers (ICIC, eICIC, feICIC)
- Basic cell selection and system acquisition
 - PSS/SSS/MIB decode
 - SIB1–SIB16 decoding
- NAS/AS security procedures
 - Snow 3G/AES/ZUC security
- CQI/RI/PMI reporting
- Paging procedures
 - Paging in Idle and Connected mode
- Dedicated bearer
 - Network-initiated dedicated bearer
 - UE-initiated dedicated bearer
- Multiple PDN connections (IPv4 and IPv6 combinations), subject to operating system support.
- Connected mode intra-LTE mobility
- Idle mode intra-LTE mobility
- iRAT between LTE / 3G for idle and connection release with redirection
- Detach procedure
 - Network-initiated detach with reattach required
 - Network-initiated detach followed by connection release

1.6 Short Message Service (SMS) Features

- Mobile-originated and mobile-terminated SMS over [IMS](#)
- Mobile-originated and mobile-terminated SMS over SGs

1.7 Position Location (GNSS)

- Customizable tracking session
- Automatic tracking session on startup
- Concurrent standalone GNSS (GPS, GLONASS, Galileo, BeiDou, QZSS)
- Assisted GPS (A-GPS) SUPL1.0
- Assisted GPS/GLONASS SUPL2.0
- gpsOneXTRA 3.1
- GNSS reception on dedicated connector or diversity connector

1.8 Supporting Documents

Several additional documents describe module design, usage, integration, and other features. See [References](#) on page 92.

1.9 Accessories

A hardware development kit (part #6001173) is available for Sierra Wireless M.2 modules. The kit contains hardware components for evaluating and developing with the module, including:

- Development board
- Cables
- Antennas
- Other accessories

For details, refer to [2] *AirPrime EM Series USB3.0 (M.2) Development Kit User Guide (Doc# 5303013)*.

For over-the-air LTE testing, ensure that suitable antennas are used.

1.10 Required Connectors

[Table 1-2](#) describes the connectors used to integrate the EM759X Embedded Module into your host device.

Table 1-2: Required Host-Module Connectors^a

Connector type	Description
RF cables — LTE/GNSS	<ul style="list-style-type: none"> ▪ Mate with M.2-spec connectors ▪ Three connector jacks (mate with I-PEX 20448-001R-081 or equivalent)
M.2 (Slot B-compatible) 67-pin edge connector	<ul style="list-style-type: none"> ▪ Slot B compatible — Per the M.2 standard ([5] <i>PCI Express NGFF (M.2) Specification Revision 1.0</i>), a generic M.2 Slot B-compatible edge connector on the motherboard uses a mechanical key to mate with the 67-pin notched module connector. ▪ Manufacturers include LOTES (part #APCI0018-P001A01), Kyocera, JAE, Tyco, and Longwell.
SIM	<ul style="list-style-type: none"> ▪ Industry-standard connector. See SIM Interface on page 29 for details.

a. Manufacturers/part numbers are for reference only and are subject to change. Choose connectors that are appropriate for your own design.

1.11 Integration Guidance

When integrating the EM759X Embedded Module, the following items, if applicable, must be considered:

- **Mounting** — Effect on temperature, shock, and vibration performance
- **Power supply** — Impact on battery drain and possible [RF](#) interference
- **Antenna location and type** — Impact on RF performance
- **Regulatory approvals** — As discussed in [Regulatory Compliance and Industry Certifications](#) on page 63.
- **Service provisioning** — Manufacturing process
- **Software** — As discussed in [Software](#) on page 57.
- **Host interface** — Compliance with interface voltage levels

1.12 Security Considerations

While the EM759X has secure boot protection for its core modem firmware, Sierra Wireless advises that the OEM / customer is responsible for implementing appropriate protections against unauthorized administrative access to the module including, but not limited to:

- Physical security of the control lines on the module
- Access control for the host-modem interface from the OS
- Disabling administrative control access from the cellular interface

2: Electrical Specifications

The system block diagram in [Figure 2-1](#) represents the EM759X module integrated into a host system. The module includes the following interfaces to the host:

- Full_Card_Power_Off#—Active-low input from the host—Low turns the module off, high turns the module on.
- W_DISABLE#—Active low input from the host—Low disables the main RF radio.
- GPS_DISABLE#—Active low input from the host—Low disables the GNSS radio receiver.
- WAKE_ON_WAN#—Active low output to the host—Low wakes the host when specific events occur.
- WWAN_LED#—Active low LED drive signal provides an indication of WAN radio ON state.
- RESET#—Active low input from the host—Low resets the module.
- Antenna—Three LTE RF connectors (main (Rx/Tx), GNSS, and auxiliary (diversity/MIMO/GNSS)). For details, see [RF Specifications](#) on page 37.
- Antenna control—Four signals that can be used to control external antenna switches.
- Dynamic power control (DPR)—Signal used to adjust Tx power to meet FCC SAR requirements. For details, see [Tx Power Control](#) on page 56.).
- Dual SIM—Supported through the interface connector. The SIM cavities / connectors must be placed on the host device for this feature.
- SIM detect—Internal pull-up on the module detects whether a SIM is present or not:
 - If a SIM is not inserted, the pin must be shorted to ground.
 - If a SIM is present, the pin will be an open circuit.
- USB—USB 2.0 and USB 3.0 interfaces to the host for data, control, and status information.

The EM759X module has two main interface areas—the host I/O connector and the RF ports. Details of these interfaces are described in the sections that follow.

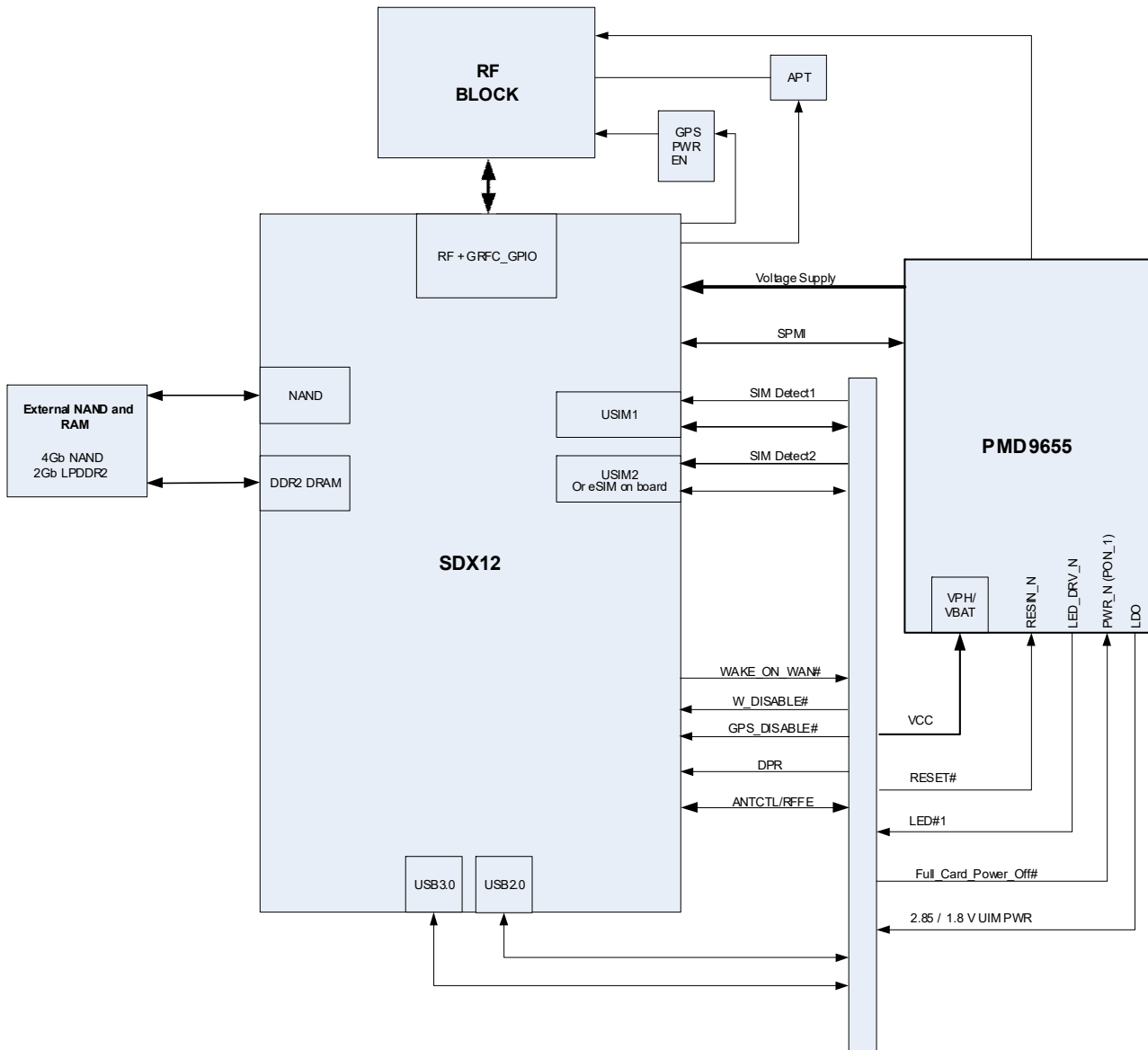

Figure 2-1: System Block Diagram

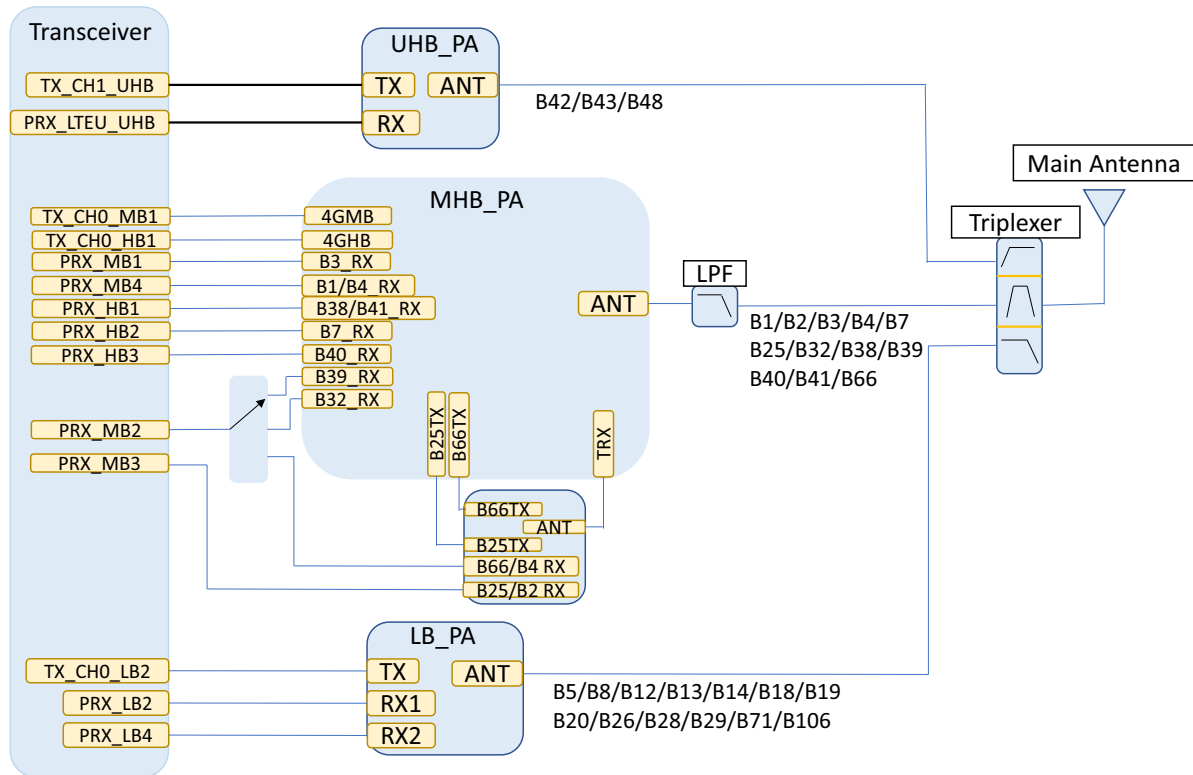

Figure 2-2: Expanded RF (Transmit) Block Diagram

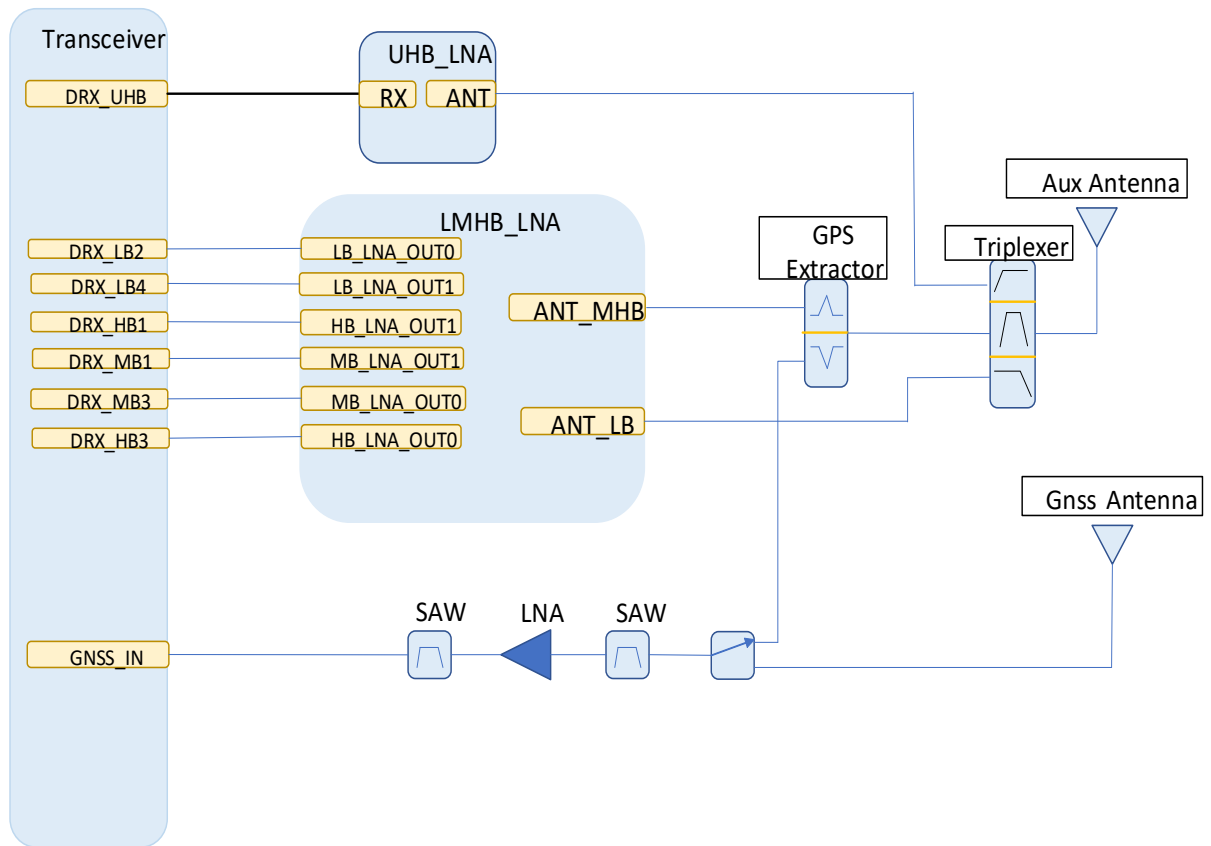

Figure 2-3: Expanded RF (Receive/GNSS) Block Diagram

2.1 M.2 (Host) Interface Pin Assignments

The EM759X module's host I/O connector provides pins for power, serial communications, and control. Pin assignments are listed in [Table 2-1](#).

Refer to the following tables for pin details based on interface types:

- [Table 2-2, Power and Ground Specifications](#), on page 27
- [Table 2-3, USB Interface](#), on page 28
- [Table 2-4, SIM Interface Signals](#), on page 30
- [Table 2-5, Module Control Signals](#), on page 33

Note: On any given interface (USB, SIM, etc.), leave unused inputs and outputs as no-connects.

Note: The host should not drive any signals to the module until > 100 ms from the start of the power-on sequence.

Table 2-1: Host Interface (75-pin) Connections — Module View^a

Pin	Signal name	Pin type ^b	Description	Direction ^c	Active state	Voltage levels (V)		
						Min	Typ	Max
1	CONFIG_3 (NC in default module configuration)		Reserved — Host must not repurpose this pin.			–	–	–
2	VCC	V	Power source	Input	Power	3.135	3.3	4.4
3	GND	V	Ground	Input	Power	–	0	–
4	VCC	V	Power source	Input	Power	3.135	3.3	4.4
5	GND	V	Ground	Input	Power	–	0	–
6	Full_Card_Power_Off# ^d	PD	Turn modem on	Input	High	0.7	–	4.4
			Turn modem off	Input	Low	-0.3	–	0.5
7	USB_D+ ^d	-	USB data positive	Input/Output	Differential	–	–	–
8	W_DISABLE# ^e	PU	Wireless Disable (WWAN radio)	Input	Low	–	–	0.4
				Input	High	0.7	–	4.4
9	USB_D- ^d	-	USB data negative	Input/Output	Differential	–	–	–
10	WWAN_LED#	OC	LED Driver	Output	Low	0	–	0.15
11	GND	V	Ground	Input	Power	–	0	–
12	Key	Notch location						
13	Key	Notch location						
14	Key	Notch location						
15	Key	Notch location						
16	Key	Notch location						
17	Key	Notch location						

Table 2-1: Host Interface (75-pin) Connections — Module View^a (Continued)

Pin	Signal name	Pin type ^b	Description	Direction ^c	Active state	Voltage levels (V)		
						Min	Typ	Max
18	Key		Notch location					
19	Key		Notch location					
20	NC		Reserved — Host must not repurpose this pin.					
21	CONFIG_0 (GND in default configuration)		Reserved — Host must not repurpose this pin.	Output	–		0	
22	NC		Reserved — Host must not repurpose this pin.					
23	WAKE_ON_WAN# ^d	OC	Wake Host	Output	Low	0	–	0.1
24	NC		Reserved — Host must not repurpose this pin.					
25	DPR	–	Dynamic power control	Input	High	1.17	1.80	2.10
				Input	Low	–0.3	–	0.63
26	GPS_DISABLE# ^e	PU	Wireless disable (GNSS radio)	Input	Low	–	–	0.4
				Input	High	0.7	–	4.4
27	GND	V	Ground	Input	Power	–	0	–
28	NC		Reserved — Host must not repurpose this pin.					
29	USB3.0_TX-		USB 3.0 Transmit Data Negative	Output	Differential	–	–	–
30	UIM1_RESET ^d	O	SIM Reset	Output	Low	0	–	0.4
					High	2.28 (3V SIM) 1.35 (1.8V SIM)	2.85 (3V SIM) 1.80 (1.8V SIM)	3.207 (3V SIM) 2.136 (1.8V SIM)
31	USB3.0_TX+		USB 3.0 Transmit Data Positive	Output	Differential	–	–	–
32	UIM1_CLK ^d	O	SIM Clock	Output	Low	0	–	0.4
					High	2.28 (3V SIM) 1.35 (1.8V SIM)	2.85 (3V SIM) 1.80 (1.8V SIM)	3.207 (3V SIM) 2.136 (1.8V SIM)
33	GND	V	Ground	Input	Power	–	0	–

Table 2-1: Host Interface (75-pin) Connections — Module View^a (Continued)

Pin	Signal name	Pin type ^b	Description	Direction ^c	Active state	Voltage levels (V)		
						Min	Typ	Max
34	UIM1_DATA ^d	PU	SIM I/O pin	Input	Low	-0.30 (3V SIM) -0.30 (1.8V SIM)	–	0.60 (3V SIM) 0.35 (1.8V SIM)
					High	2.10 (3V SIM) 1.26 (1.8V SIM)	2.85 (3V SIM) 1.80 (1.8V SIM)	3.20 (3V SIM) 2.10 (1.8V SIM)
				Output	Low	0	–	0.4
					High	2.28 (3V SIM) 1.35 (1.8V SIM)	2.85 (3V SIM) 1.80 (1.8V SIM)	3.207 (3V SIM) 2.136 (1.8V SIM)
35	USB3.0_RX-		USB 3.0 Receive Data Negative	Input	Differential	–	–	–
36	UIM1_PWR ^d	V	SIM VCC supply	Output	Power	2.7 (3V SIM) 1.74 (1.8V SIM)	2.85 (3V SIM) 1.80 (1.8V SIM)	3.2 (3V SIM) 1.85 (1.8V SIM)
37	USB3.0_RX+		USB 3.0 Receive Data Positive	Input	Differential	–	–	–
38	NC		Reserved					
39	GND	V	Ground	Input	Power	–	0	–
40	SIM_DETECT_2		SIM2 indication	Input		0 V — SIM not present Open circuit — SIM present		
41	NC		Reserved <i>Note: Leave pin floating on host side</i>					
42	UIM2_DATA ^d	PU	SIM2 IO pin	Input	Low	-0.30 (3V SIM) -0.30 (1.8V SIM)	–	0.60 (3V SIM) 0.35 (1.8V SIM)
					High	2.10 (3V SIM) 1.26 (1.8V SIM)	2.85 (3V SIM) 1.80 (1.8V SIM)	3.20 (3V SIM) 2.10 (1.8V SIM)
				Output	Low	0	–	0.4
					High	2.28 (3V SIM) 1.35 (1.8V SIM)	2.85 (3V SIM) 1.80 (1.8V SIM)	3.207 (3V SIM) 2.136 (1.8V SIM)

Table 2-1: Host Interface (75-pin) Connections — Module View^a (Continued)

Pin	Signal name	Pin type ^b	Description	Direction ^c	Active state	Voltage levels (V)		
						Min	Typ	Max
43	NC		Reserved <i>Note: Leave pin floating on host side</i>					
44	UIM2_CLK ^d	O	SIM2 Clock	Output	Low	0	–	0.4
					High	2.28 (3V SIM) 1.35 (1.8V SIM)	2.85 (3V SIM) 1.80 (1.8V SIM)	3.207 (3V SIM) 2.136 (1.8V SIM)
45	GND	V	Ground	Input	Power	–	0	–
46	UIM2_RESET ^d	O	SIM2 Reset	Output	Low	0	–	0.4
					High	2.28 (3V SIM) 1.35 (1.8V SIM)	2.85 (3V SIM) 1.80 (1.8V SIM)	3.207 (3V SIM) 2.136 (1.8V SIM)
47	NC		Reserved <i>Note: Leave pin floating on host side</i>					
48	UIM2_PWR ^d	V	SIM2 VCC supply	Output	Power	2.7 (3V SIM) 1.74 (1.8V SIM)	2.85 (3V SIM) 1.80 (1.8V SIM)	3.2 (3V SIM) 1.85 (1.8V SIM)
49	NC		Reserved <i>Note: Leave pin floating on host side</i>					
50	NC		Reserved <i>Note: Leave pin floating on host side</i>					
51	GND	V	Ground	Input	Power	–	0	–
52	NC		Reserved <i>Note: Leave pin floating on host side</i>					
53	NC		Reserved <i>Note: Leave pin floating on host side</i>					
54	NC		Reserved <i>Note: Leave pin floating on host side</i>					

Table 2-1: Host Interface (75-pin) Connections — Module View^a (Continued)

Pin	Signal name	Pin type ^b	Description	Direction ^c	Active state	Voltage levels (V)		
						Min	Typ	Max
55	NC		Reserved <i>Note: Leave pin floating on host side</i>					
56	NC		Reserved — Host must not repurpose this pin.					
57	GND	V	Ground	Input	Power	–	0	–
58	NC		Reserved — Host must not repurpose this pin.					
59	ANTCTLO (GPIO1)		Customer-defined external switch control for multiple antennas	Output	High	1.35	–	1.80
				Output	Low	0	–	0.45
60	Reserved — Host must not repurpose this pin and should leave it not connected.							
61	ANTCTL1 (GPIO2)		Customer-defined external switch control for multiple antennas	Output	High	1.35	–	1.80
				Output	Low	0	–	0.45
62	Reserved — Host must not repurpose this pin and should leave it not connected.							
63	ANTCTL2 (GPIO3)		Customer-defined external switch control for multiple antennas	Output	High	1.35	–	1.80
				Output	Low	0	–	0.45
64	Reserved — Host must not repurpose this pin and should leave it not connected.							
65	ANTCTL3 (GPIO4)		Customer-defined external switch control for multiple antennas	Output	High	1.35	–	1.80
				Output	Low	0	–	0.45
66	SIM1_DETECT ^d	PU	SIM indication	Input		0 V — SIM not present Open circuit — SIM present		
67	RESET#	PU	Reset module	Input	Low	-0.3	–	0.63
68	NC		Reserved					
69	CONFIG_1 (GND in default configuration)		Reserved — Host must not repurpose this pin.	Output	–		0	
70	VCC	V	Power source	Input	Power	3.135	3.3	4.4

Table 2-1: Host Interface (75-pin) Connections — Module View^a (Continued)

Pin	Signal name	Pin type ^b	Description	Direction ^c	Active state	Voltage levels (V)		
						Min	Typ	Max
71	GND	V	Ground	Input	Power	–	0	–
72	VCC	V	Power source	Input	Power	3.135	3.3	4.4
73	GND	V	Ground	Input	Power	–	0	–
74	VCC	V	Power source	Input	Power	3.135	3.3	4.4
75	CONFIG_2 (NC in default module configuration)	V	Reserved	Output	–	–		–

- a. All values are preliminary and subject to change.
- b. I— Input; O— Digital output; OC— Open Collector output; PU— Digital input (internal pull-up); PD— Digital input (internal pull-down); V— Power or ground
- c. Signal directions are from module’s point of view (e.g. ‘Output’ from module to host, ‘Input’ to module from host.)
- d. Required signal
- e. Sierra Wireless recommends that the host implement an open collector driver where a Low signal will turn the module off or enter low power mode, and a high signal will turn the module on or leave low power mode.

2.2 Power Supply

The host provides power to the EM759X module through multiple power and ground pins as summarized in [Table 2-2](#).

The host must provide safe and continuous power (via battery or a regulated power supply) at all times; the module does not have an independent power supply, or protection circuits to guard against electrical issues.

Table 2-2: Power and Ground Specifications

Name	Pins	Specification	Min	Typ	Max	Units
VCC (3.3V)	2, 4, 70, 72, 74	Voltage range	See Table 2-1			
		Ripple voltage	-	-	100	mV _{pp}
GND	3, 5, 11, 27, 33, 39, 45, 51, 57, 71, 73	-	-	0	-	V

2.3 USB Interface

Important: Host support for USB 2.0 or USB 3.0 signals is required.

Note: USB2.0 full speed and low speed are not supported.

The EM759X module supports USB 2.0 and USB 3.0 interfaces for communication between the host and module.

The USB interface complies with the [6] *Universal Serial Bus Specification, Rev 2.0* and [7] *Universal Serial Bus Specification, Rev 3.0* (subject to limitations described below), and the host platform must be designed to the same standards.

Table 2-3: USB Interface

	Name	Pin	Description
USB 2.0	USB_D+	7	(USB 2 High speed) Data positive
	USB_D-	9	(USB 2 High speed) Data negative
USB 3.0	USB3_TX ^{-a}	29	(USB 3 Superspeed) Transmit data negative
	USB3_TX ^{+a}	31	(USB 3 Superspeed) Transmit data positive
	USB3_RX ^{-a}	35	(USB 3 Superspeed) Receive data negative
	USB3_RX ^{+a}	37	(USB 3 Superspeed) Receive data positive

a. Signal directions (Tx/Rx) are from the module's point of view.

2.3.1 Host-side Recommendation

Note: When designing the host device, careful PCB layout practices must be followed.

Series capacitors are recommended on the host-side USB 3.0 Rx signals (no capacitors required for the Tx signals), as shown below.

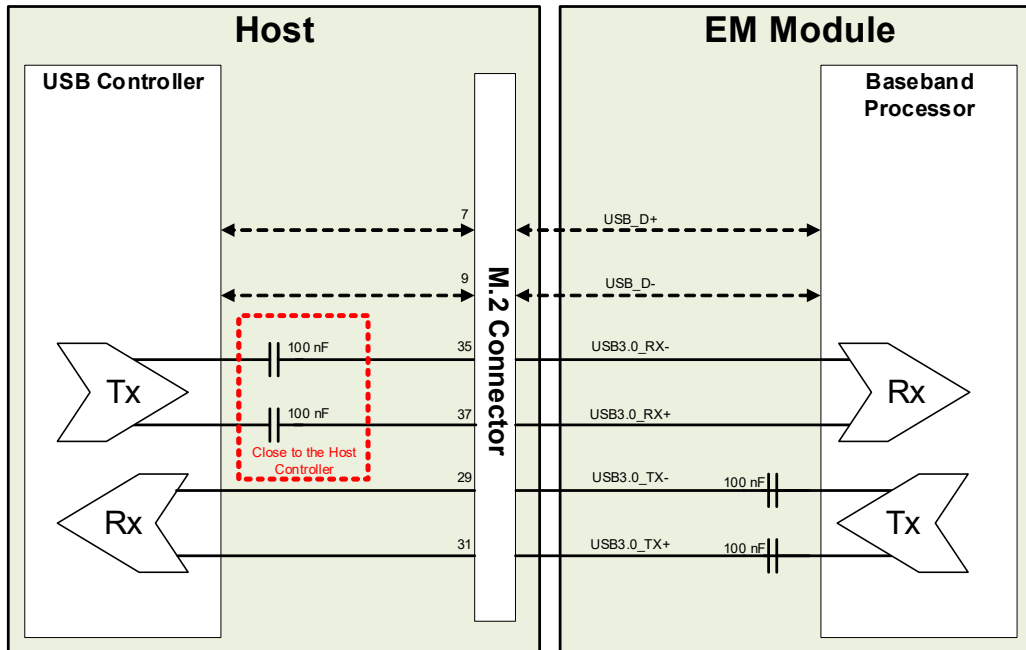

Figure 2-4: Recommended Capacitor Placement for USB 3.0 Signals

2.3.2 USB Throughput Performance

This device has been designed to achieve optimal performance and maximum throughput using USB SuperSpeed mode (USB 3.0). Although the device may operate with a high speed host, throughput performance will be on an “as is” basis and must be characterized by the OEM. Note that throughput will be reduced and may vary significantly based on packet size, host interface, and firmware revision.

2.4 SIM Interface

Note: Host support for SIM interface signals is required.

The module supports up to two SIMs (Subscriber Identity Module) (1.8 V or 3 V). Each SIM holds information for a unique account, allowing users to optimize their use of each account on multiple devices.

The SIM pins (Table 2-4 on page 30) provide the connections necessary to interface to SIM sockets located on the host platform as shown in Figure 2-5 on page 31. Voltage levels over this interface comply with 3GPP standards.

The SIM connector types used depend on how the host platform exposes the SIM sockets.

Table 2-4: SIM Interface Signals

SIM	Name	Pin	Description	SIM contact ^a	Notes
Primary	UIM1_RESET	30	Reset	2	Active low SIM reset
	UIM1_CLK	32	Serial clock	3	Serial clock for SIM data
	UIM1_DATA	34	Data I/O	7	Bi-directional SIM data line
	UIM1_PWR	36	SIM voltage	1	Power supply for SIM
	SIM_DETECT	66	SIM indication	–	Input from host indicating whether SIM is present or not <ul style="list-style-type: none"> ▪ Grounded if no SIM is present ▪ No-connect (floating) if SIM is inserted
	UIM_GND		Ground	5	Ground reference UIM_GND is common to module ground
Secondary	UIM2_RESET	46	Reset	2	Active low SIM reset
	UIM2_CLK	44	Serial clock	3	Serial clock for SIM data
	UIM2_DATA	42	Data I/O	7	Bi-directional SIM data line
	UIM2_PWR	48	SIM voltage	1	Power supply for SIM
	SIM_DETECT_2	40	SIM indication	–	Input from host indicating whether SIM is present or not <ul style="list-style-type: none"> ▪ Grounded if no SIM is present ▪ No-connect (floating) if SIM is inserted
	UIM2_GND		Ground	5	Ground reference UIM2_GND is common to module ground

a. See [Figure 2-6](#) on page 31 for SIM card contacts.

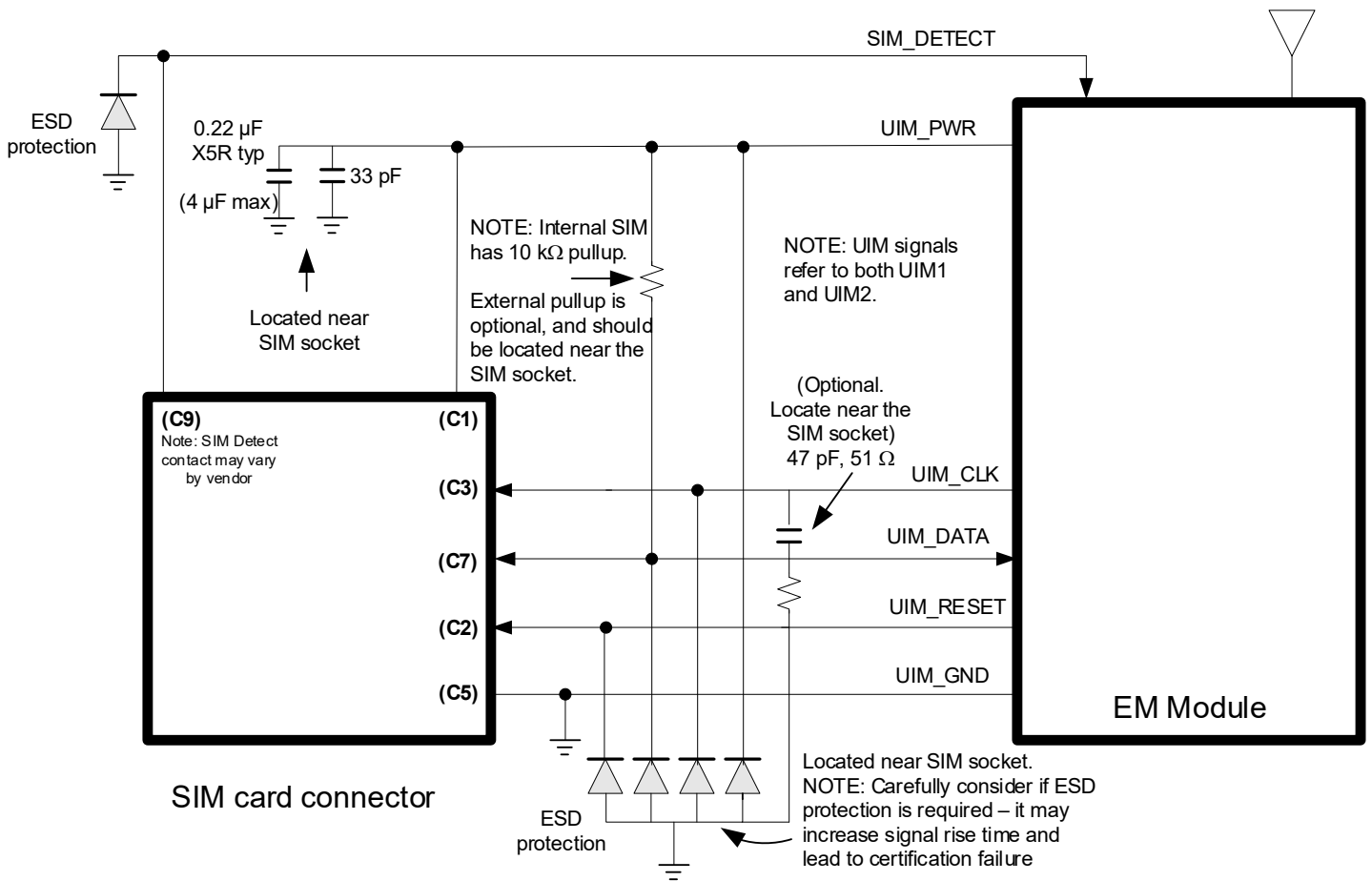

Figure 2-5: SIM Application Interface (applies to both SIM interfaces)

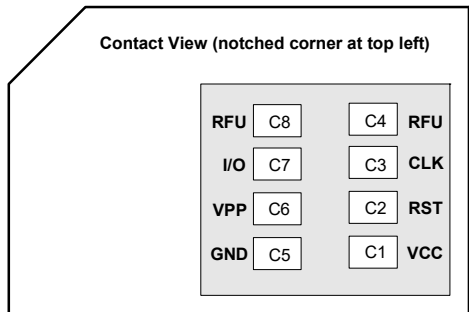

Figure 2-6: SIM Card Contacts (Contact View)

2.4.1 SIM Implementation

Note: For interface design requirements, refer to ETSI TS 102 230 V5.5.0, section 5.2.

When designing the remote SIM interface, you must make sure that SIM signal integrity is not compromised.

Some design recommendations include:

- Total impedance of the VCC and GND connections to the SIM, measured at the module connector, should be less than $1\ \Omega$ to minimize voltage drop (includes any trace impedance and lumped element components — inductors, filters, etc.).
- Position the SIM connector ≤ 10 cm from the module. If a longer distance is required because of the host platform design, use a shielded wire assembly — connect one end as close as possible to the SIM connector and the other end as close as possible to the module connector. The shielded assembly may help shield the SIM interface from system noise.
- Reduce crosstalk on the UIM1_DATA and UIM2_DATA lines to reduce the risk of failures during GCF approval testing.
- Avoid routing the clock and data lines for each SIM (UIM1_CLK/UIM1_DATA, UIM2_CLK/UIM2_DATA) in parallel over distances > 2 cm — cross-coupling of a clock and data line pair can cause failures.
- 3GPP has stringent requirements for I/O rise time ($< 1\ \mu\text{s}$), signal level limits, and noise immunity — consider this carefully when developing your PCB layout.
 - Keep signal rise time $< 1\ \mu\text{s}$ — keep SIM signals as short as possible, and keep very low capacitance traces on the data and clock signals (UIM1_CLK, UIM1_DATA, UIM2_CLK, UIM2_DATA). High capacitance increases signal rise time, potentially causing your device to fail certification tests.
- Add external pull-up resistors ($15\ \text{k}\Omega$ – $30\ \text{k}\Omega$), if required, between the data and power lines for each SIM (UIM1_DATA/UIM1_PWR, UIM2_DATA/UIM2_PWR) to optimize the signal rise time.
- VCC line should be decoupled close to the SIM socket.
- Make sure that placement and routing of SIM signals and connectors supports SIM clock rates up to 5 MHz (per 3GPP specification).
- You must decide whether additional ESD protection is required for your product, as it is dependent on the platform, mechanical enclosure, and SIM connector design. The SIM pins will require additional ESD protection if they are exposed to high ESD levels (i.e., can be touched by a user).
- Putting optional decoupling capacitors on the SIM power lines (UIM1_PWR, UIM2_PWR) near the SIM sockets is recommended — the longer the trace length (impedance) from the socket to the module, the greater the capacitance requirement to meet compliance tests.
- Putting an optional series capacitor and resistor termination (to ground) on the clock line (UIM1_CLK, UIM2_CLK) at the SIM socket to reduce EMI and increase signal integrity is recommended if the trace length between the SIM socket and module is long — a $47\ \text{pF}$ capacitor and $50\ \Omega$ resistor are recommended.
- Test your first prototype host hardware with a Comprion IT³ SIM test device at a suitable testing facility.

2.5 Control Interface (Signals)

The EM759X module provides signals for:

- Waking the host when specific events occur
- Host platform control of the module's radios
- Host platform control of module power
- LED driver output (i.e., module status indication to host)

Note: Host support for Full_Card_Power_Off# is required, and support for other signals in [Table 2-5](#) is optional.

These signals are summarized in [Table 2-5](#) and the subsections that follow.

Table 2-5: Module Control Signals

Name	Pin	Description	Type ^a
Full_Card_Power_Off#	6	On/off control	PD
W_DISABLE#	8	Wireless disable (Main RF)	PU
WWAN_LED#	10	LED driver	OC
WAKE_ON_WAN#	23	Wake host	O
GPS_DISABLE#	26	Wireless disable (GNSS)	PU
RESET#	67	Reset module	PU

- a. O—Digital pin Output; OC—Open Collector output; PD—Digital pin Input, internal pull-down; PU—Digital pin Input, internal pull-up

2.5.1 WAKE_ON_WAN# — Wake Host

Note: Host support for WAKE_ON_WAN# is optional.

The EM759X module uses WAKE_ON_WAN# to wake the host when specific events occur.

The host must provide a 5k Ω –100k Ω pull-up resistor that considers total line capacitance (including parasitic capacitance) such that when WAKE_ON_WAN# is deasserted, the line will rise to 3.3 V (Host power rail) in < 100 ns.

See [Figure 2-7](#) for a recommended implementation.

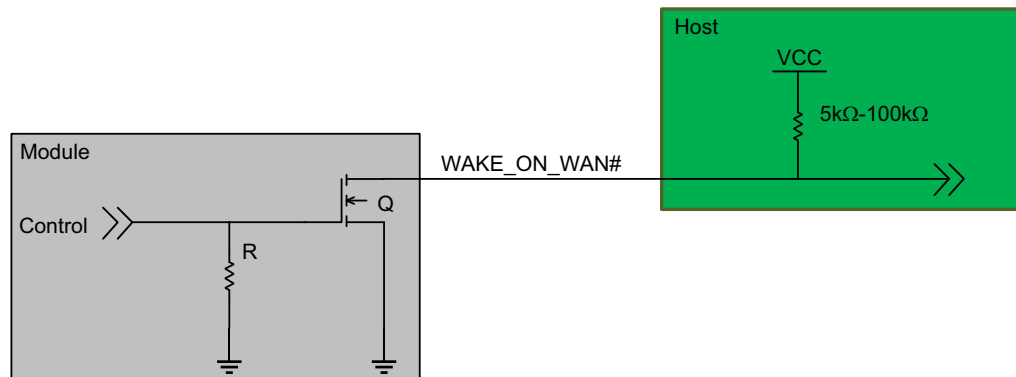

Figure 2-7: Recommended WAKE_ON_WAN# Connection

2.5.2 W_DISABLE# (Wireless Disable) and GPS_DISABLE# (GNSS Disable)

Note: Host support for wireless/GNSS disable signals is optional.

The host platform uses W_DISABLE# to enable/disable the WWAN or radio modem, and GPS_DISABLE# to enable/disable GNSS functionality.

Letting these signals float high allows the module to operate normally. These pins have 100 kΩ pull-up resistors. See Figure 2-8 for a recommended implementation.

When integrating with your host platform, keep the following in mind:

- The signal is an input to the module and should be driven LOW to turn the radio off, or HIGH or floating to keep it on.
- If the host never needs to assert this power state control to the module, leave this signal unconnected from the host interface.

Table 2-6: W_DISABLE# / GPS_DISABLE# Usage

Name	Pin	Description / notes
W_DISABLE#	8	Enable/disable the WWAN or radio modem ^a . When disabled, the modem cannot transmit or receive. <ul style="list-style-type: none"> ▪ Keep modem always on — Leave as not connected or drive HIGH. ▪ Turn modem off — Drive LOW.
GPS_DISABLE#	26	Enable/disable GNSS functionality ^a <ul style="list-style-type: none"> ▪ Enable GNSS functionality — Leave as not connected or drive HIGH. ▪ Disable GNSS functionality — Drive LOW. ▪ For details on enabling/disabling GNSS functionality, refer to the AT!CUSTOM="GPSEENABLE" command in [1] Sierra Wireless EM759X AT Command Reference (Doc# 41114426).

a. Sierra Wireless recommends that the host implement an open collector driver where a Low signal turns off the modem or disables GNSS functionality, and a high signal turns on the modem or enables GNSS functionality.

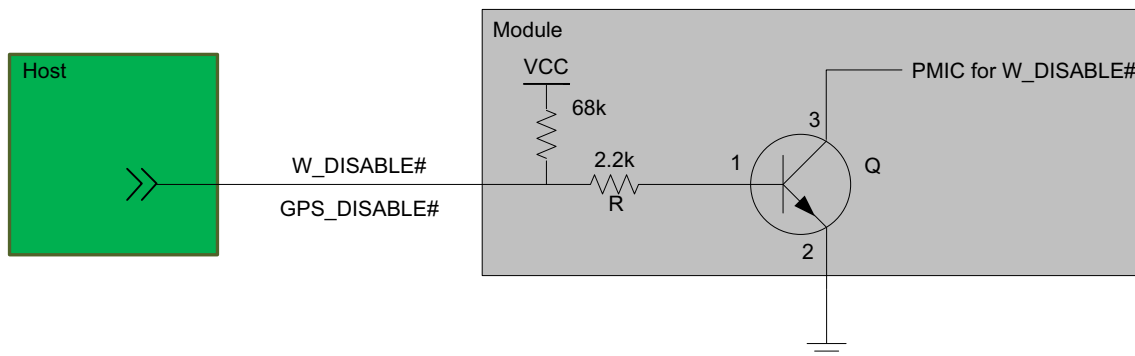

Figure 2-8: Recommended Wireless Disable Connection

2.5.3 Full_Card_Power_Off# and RESET#

Note: Host support for Full_Card_Power_Off# is required, and support for RESET# is optional.

Full_Card_Power_Off# and RESET# are inputs to the module that the host uses as described in [Table 2-7](#).

For timing details, see [Power On/Off Timing for USB Port](#) on page 52.

Table 2-7: Full_Card_Power_Off# and RESET# Usage

Name	Pin	Description / notes
Full_Card_Power_Off#	6	<p>Powers the module on/off</p> <ul style="list-style-type: none"> Signal is required. Pull HIGH to keep the module on. To keep the module always on: <ul style="list-style-type: none"> Tie the pin directly to a host GPIO (1.8V), or Use an external pull-up to pull the signal high (10 kΩ–20 kΩ for 1.8V, 75 kΩ–100 kΩ for VCC rail). Note that a larger-value resistor will reduce leakage current. To power off the module, see Required Shutdown Sequence on page 55.
RESET#	67	<p>Resets the module</p> <ul style="list-style-type: none"> Signal is optional. The module will operate correctly if the pin is left disconnected on the host. If the firmware is running, asserting RESET# has different effects depending on the duration of the assertion: <ul style="list-style-type: none"> Assert for 400 ms–9 sec — Perform a software reset. (See Figure 4-5, Case 2.) Assert for 9 sec to ~12 sec — Perform a graceful shutdown and restart, or perform a software reset if the shutdown is interrupted. (See Figure 4-5, Case 4.) <p>The graceful shutdown process starts 9 seconds after asserting RESET# and completes after approximately 3 seconds (total assertion time is ~12 seconds).</p> <ul style="list-style-type: none"> Graceful shutdown and restart—If the shutdown process completed before RESET# is deasserted, the module restarts. Software reset—If the shutdown process is interrupted when RESET# is deasserted, a software reset occurs. Assert for > 12 sec — Perform a graceful shutdown and restart. (See Figure 4-5, Case 3.) If the firmware hangs, assert RESET# for > 2 seconds and then deassert to perform a hardware reset. (See Figure 4-5, Case 5.) (Note — If RESET# is asserted for < 2 seconds, nothing happens.) Otherwise, leave the signal floating or high impedance (the module will remain operational because the module has a pull-up resistor to an internal reference 1.8V voltage in place). <div style="text-align: center;"> <p>RESET# High Low</p> <p>400 ms–12 sec</p> </div> <ul style="list-style-type: none"> The signal requires an open collector input from the host. <p>Caution: RESET# should not be driven or pulled to a logic high level by the host, as this may cause damage to the module.</p>

2.5.4 WWAN_LED# — LED Output

Note: Host support for WWAN_LED# is optional.

The configuration for the LED shown in Figure 2-9 is customizable. Contact your Semtech account representative for details.

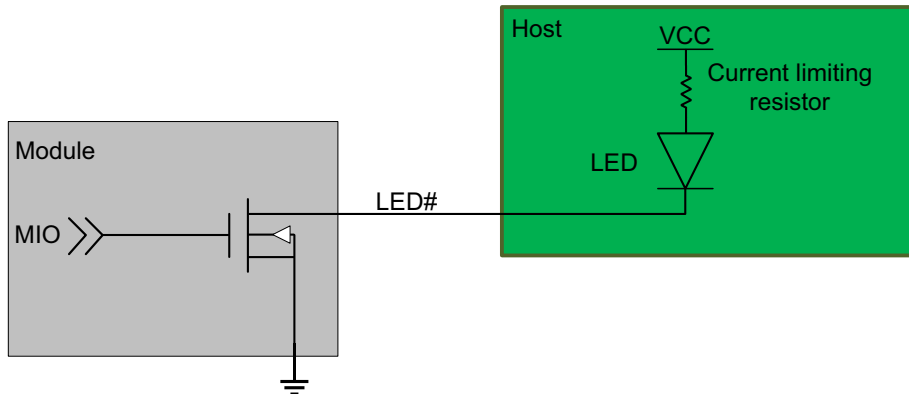

Figure 2-9: Recommended LED Connection

2.6 Antenna Control

Note: Host support for the antenna control signals is optional.

The EM759X module provides four output signals (listed in [Table 2-8](#)) that may be used for host designs that incorporate tunable antennas. Customers can configure these signals as appropriate for the operating band(s) using the command AT!ANTSEL. (See [1] *Sierra Wireless EM759X AT Command Reference (Doc# 41114426)* for details.)

Note: To avoid detuning the PCC band, customers must make sure there are no GPIO state conflicts between the PCC and SCC for all supported CA combinations.

Table 2-8: Antenna Control Signals

Name	Pin	Description
ANT_CTRL0	59	Customer-defined external switch controls for tunable antennas.
ANT_CTRL1	61	
ANT_CTRL2	63	
ANT_CTRL3	65	

3: RF Specifications

The EM759X includes three RF connectors for use with host-supplied antennas:

- Main RF connector — Tx/Rx path
- GNSS RF connector — Dedicated GPS, GLONASS, BeiDou, Galileo, and QZSS
- Auxiliary RF connector — Diversity, MIMO, GPS, GLONASS, BeiDou, Galileo, and QZSS
- The module does not have integrated antennas.

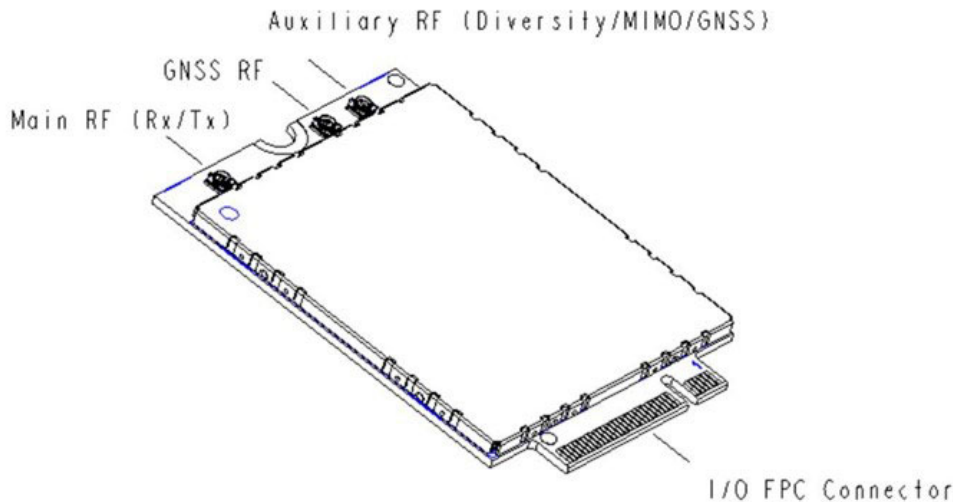

Figure 3-1: Module Connectors

3.1 RF Connections

When attaching antennas to the module:

- Use RF plug connectors that are compatible with I-PEX (20449-001E (MHF4)) RF receptacle connectors.
- Match coaxial connections between the module and the antenna to 50 Ω .
- Minimize RF cable losses to the antenna; the recommended maximum cable loss for antenna cabling is 0.5 dB.
- To ensure best thermal performance, use the mounting hole (if possible) to attach (ground) the device to a metal chassis.

Note: If the antenna connection is shorted or open, the modem will not sustain permanent damage.

3.1.1 Shielding

The module is fully shielded to protect against EMI. The shielding must not be removed.

3.2 Antennas and Cabling

When selecting the antenna and cable, it is critical to RF performance to match antenna gain and cable loss.

Note: For detailed electrical performance criteria, see [Appendix A: Antenna Specification](#) on page 67.

3.2.1 Choosing the Correct Antenna and Cabling

When matching antennas and cabling:

- The antenna (and associated circuitry) should have a nominal impedance of 50 Ω with a return loss of better than 10 dB across each frequency band of operation.
- The system gain value affects both radiated power and regulatory (FCC, IC, CE, etc.) test results.

3.2.2 Designing Custom Antennas

Consider the following points when designing custom antennas:

- A skilled RF engineer should do the development to ensure that the RF performance is maintained.

3.2.3 Determining the Antenna's Location

When deciding where to put the antennas:

- Antenna location may affect RF performance. Although the module is shielded to prevent interference in most host platforms, the antenna placement is still very important — if the host platform is insufficiently shielded, high levels of broadband or spurious noise can degrade the module's performance.
- Connecting cables between the module and the antenna must have 50 Ω impedance. If the impedance of the module is mismatched, RF performance is reduced significantly.
- Antenna cables should be routed, if possible, away from noise sources (switching power supplies, LCD assemblies, etc.). If the cables are near the noise sources, the noise may be coupled into the RF cable and into the antenna. See [Interference from Other Wireless Devices](#) on page 39.

3.2.4 Disabling the Diversity Antenna

Certification testing of a device with an integrated EM759X module may require the module's main and diversity antennas to be tested separately.

To facilitate this testing, receive diversity can be enabled / disabled using AT commands:

- `!RXDEN` — Used to enable / disable diversity for single-cell call (no carrier aggregation).
- `!LTERXCONTROL` — Used to enable / disable paths (in carrier aggregation scenarios) after a call is set up.

Important: *LTE networks expect modules to have more than one antenna enabled for proper operation. Therefore, customers must not commercially deploy their systems with the diversity antenna disabled.*

For details, refer to [1] *Sierra Wireless EM759X AT Command Reference (Doc# 41114426)*.

Note: A diversity antenna is used to improve connection quality and reliability through redundancy. Because two antennas may experience different interference effects (signal distortion, delay, etc.), when one antenna receives a degraded signal, the other may not be similarly affected.

3.3 Ground Connection

When connecting the module to system ground:

- Prevent noise leakage by establishing a very good ground connection to the module through the host connector.
- Connect to system ground using the mounting hole shown in [Figure 3-1](#) on page 37.

- Minimize ground noise leakage into the RF. Depending on the host board design, noise could potentially be coupled to the module from the host board. This is mainly an issue for host designs that have signals traveling along the length of the module, or circuitry operating at both ends of the module interconnects.

3.4 Interference and Sensitivity

Interference sources can affect the module's RF performance (RF desense). Common sources include power supply noise and device-generated RF.

RF desense can be addressed through a combination of mitigation techniques ([Methods to Mitigate Decreased Rx Performance](#) on page 39) and radiated sensitivity measurement ([Radiated Sensitivity Measurement](#) on page 40).

3.4.1 Interference from Other Wireless Devices

Wireless devices operating inside the host device can cause interference that affects the module.

To determine the most suitable locations for antennas on your host device, evaluate each wireless device's radio system, considering the following:

- Any harmonics, sub-harmonics, or cross-products of signals generated by wireless devices that fall in the module's Rx range may cause spurious response, resulting in decreased Rx performance.
- The Tx power and corresponding broadband noise of other wireless devices may overload or increase the noise floor of the module's receiver, resulting in Rx desense.

The severity of this interference depends on the closeness of the other antennas to the module's antenna. To determine suitable locations for each wireless device's antenna, thoroughly evaluate your host device's design.

3.4.2 Host-generated RF Interference

All electronic computing devices generate RF interference that can negatively affect the receive sensitivity of the module.

Proximity of host electronics to the antenna in wireless devices can contribute to decreased Rx performance. Components that are most likely to cause this include:

- Microprocessor and memory
- Display panel and display drivers
- Switching-mode power supplies

3.4.3 Device-generated RF Interference

The module can cause interference with other devices. Wireless devices such as Sierra Wireless embedded modules transmit in bursts (pulse transients) for set durations (RF burst frequencies). Hearing aids and speakers convert these burst frequencies into audible frequencies, resulting in audible noise.

3.4.4 Methods to Mitigate Decreased Rx Performance

It is important to investigate sources of localized interference early in the design cycle. To reduce the effect of device-generated RF on Rx performance:

- Put the antenna as far as possible from interference sources. Note, however, that the module may be less convenient to use.

- Shield the host device. The module itself is well shielded to avoid external interference. However, the antenna cannot be shielded for obvious reasons. In most instances, it is necessary to employ shielding on host device components (such as the main processor and parallel bus) that have the highest RF emissions.
- Filter out unwanted high-order harmonic energy by using discrete filtering on low frequency lines.
- Form shielding layers around high-speed clock traces by using multi-layer PCBs.
- Route antenna cables away from noise sources.

3.4.5 Radiated Spurious Emissions (RSE)

When designing an antenna for use with Sierra Wireless embedded modules, the host device with a Sierra Wireless embedded module must satisfy any applicable standards/local regulatory bodies for radiated spurious emission (RSE) for receive-only mode and for transmit mode (transmitter is operating).

Note that antenna impedance affects radiated emissions, which must be compared against the conducted 50 Ω emissions baseline. (Sierra Wireless embedded modules meet the 50 Ω conducted emissions requirement.)

3.5 Radiated Sensitivity Measurement

A wireless host device contains many noise sources that contribute to a reduction in Rx performance.

To determine the extent of any receiver performance desensitization due to self-generated noise in the host device, over-the-air (OTA) or radiated testing is required. This testing can be performed by Sierra Wireless or you can use your own OTA test chamber for in-house testing.

3.5.1 Sierra Wireless' Sensitivity Testing and Desensitization Investigation

Although Sierra Wireless embedded modules are designed to meet network operator requirements for receiver performance, they are still susceptible to various performance inhibitors.

As part of the Engineering Services package, Sierra Wireless offers modem OTA sensitivity testing and desensitization (desense) investigation. For more information, contact your Semtech account manager or the Sales Desk (see [Contact Information](#) on page 3).

Note: Sierra Wireless has the capability to measure TIS (Total Isotropic Sensitivity) and TRP (Total Radiated Power) according to CTIA's published test procedure.

3.5.2 Sensitivity vs. Frequency

Sensitivity definitions for supported RATs:

- UMTS bands — Sensitivity is defined as the input power level in dBm that produces a BER (Bit Error Rate) of 0.1%. Sensitivity should be measured at all UMTS frequencies across each band.
- LTE bands — Sensitivity is defined as the RF level at which throughput is 95% of maximum.

3.6 Supported RATs

The EM759X module supports:

- LTE:
 - Multiple-band LTE — See [Table 3-1](#) (supported bands) and [Table 3-2](#) on page 42 (LTE bandwidth support).
 - LTE Advanced carrier aggregation — See [Carrier Aggregations](#) for details.
- WCDMA:
 - Multiple-band WCDMA/HSPA/HSPA+/DC-HSPA+ — See [Table 3-1](#).
 - Multiple-band WCDMA receive diversity
- [inter-RAT](#) and inter-frequency cell reselection and handover between supported frequency bands
- GNSS:
 - GPS, GLONASS, BeiDou, Galileo, QZSS — See [Table 3-6](#) on page 45.

3.6.1 Supported Bands

Table 3-1: Supported Frequency Bands, by RAT (LTE/3G)

Band#	LTE (B<band#>)	3G (Band<band#>)	Frequency (Tx)	Frequency (Rx)
1	Y	Y	1920–1980 MHz	2110–2170 MHz
2	Y	Y	1850–1910 MHz	1930–1990 MHz
3	Y	—	1710–1785 MHz	1805–1880 MHz
4	Y	Y	1710–1755 MHz	2110–2155 MHz
5	Y	Y	824–849 MHz	869–894 MHz
6	—	Y	830–840 MHz	875–885 MHz
7	Y	—	2500–2570 MHz	2620–2690 MHz
8	Y	Y	880–915 MHz	925–960 MHz
9	—	Y	1749.9–1784.9 MHz	1844.9–1879.9 MHz
12	Y	—	699–716 MHz	729–746 MHz
13	Y	—	777–787 MHz	746–756 MHz
14	Y	—	788–798 MHz	758–768 MHz
18	Y	—	815–830 MHz	860–875 MHz
19	Y	Y	830–845 MHz	875–890 MHz
20	Y	—	832–862 MHz	791–821 MHz
25	Y	—	1850–1915 MHz	1930–1995 MHz
26	Y	—	814–849 MHz	859–894 MHz
28	Y	—	703–748 MHz	758–803 MHz
29	Y	—	n/a	717–728 MHz
32	Y	—	n/a	1452–1496 MHz

Table 3-1: Supported Frequency Bands, by RAT (LTE/3G) (Continued)

Band#	LTE (B<band#>)	3G (Band<band#>)	Frequency (Tx)	Frequency (Rx)
38	Y	—	2570–2620 MHz (TDD)	
39	Y	—	1880–1920 MHz (TDD)	
40	Y	—	2300–2400 MHz (TDD)	
41	Y	—	2496–2690 MHz (TDD)	
42	Y	—	3400–3600 MHz (TDD) ^a	
43	Y	—	3600–3800 MHz (TDD)	
48	Y	—	3550–3700 MHz (TDD)	
66	Y	—	1710–1780 MHz	2110–2200 MHz
71	Y	—	663–698 MHz	617–652 MHz
106	Y	—	896–901 MHz	935–940 MHz

a. LTE B42 Tx frequency is restricted to 3450–3600 MHz in Canada.

Table 3-2: LTE Bandwidth Support^a

Band	1.4 MHz	3 MHz	5 MHz	10 MHz	15 MHz	20 MHz
B1	—	—	Y	Y	Y	Y
B2	Y	Y	Y	Y	Y ^b	Y ^b
B3	Y	Y	Y	Y	Y ^b	Y ^b
B4	Y	Y	Y	Y	Y	Y
B5	Y	Y	Y	Y ^b	—	—
B7	—	—	Y	Y	Y ^c	Y ^{b,c}
B8	Y	Y	Y	Y ^b	—	—
B12	Y	Y	Y ^b	Y ^b	—	—
B13	—	—	Y ^b	Y ^b	—	—
B14	—	—	Y ^b	Y ^b	—	—
B18	—	—	Y	Y ^b	Y ^b	—
B19	—	—	Y	Y ^b	Y ^b	—
B20	—	—	Y	Y ^b	Y ^b	Y ^b
B25	Y	Y	Y	Y	Y ^b	Y ^b
B26	Y	Y	Y	Y ^b	Y ^b	—
B28	—	Y	Y	Y ^b	Y ^b	Y ^{b,d}
B29	—	Y	Y	Y	—	—
B32	—	—	Y	Y	Y	Y
B38	—	—	Y	Y	Y ^c	Y ^c

Table 3-2: LTE Bandwidth Support^a (Continued)

Band	1.4 MHz	3 MHz	5 MHz	10 MHz	15 MHz	20 MHz
B39	—	—	Y	Y	Y ^c	Y ^c
B40	—	—	Y	Y	Y	Y
B41	—	—	Y	Y	Y	Y
B42	—	—	Y	Y	Y	Y
B43	—	—	Y	Y	Y	Y
B48	—	—	Y	Y	Y	Y
B66	Y	Y	Y	Y	Y	Y
B71	—	—	Y	Y ^b	Y ^b	Y ^{b,e}
B106	Y	Y	—	—	—	—

- Table contents are derived from 3GPP TS 36.521-1 v12.6.0, table 5.4.2.1-1.
- Bandwidth for which a relaxation of the specified UE receiver sensitivity requirement (Clause 7.3 of 3GPP TS 36.521-1 v12.6.0) is allowed.
- Bandwidth for which uplink transmission bandwidth can be restricted by the network for some channel assignments in FDD/TDD co-existence scenarios in order to meet unwanted emissions requirements (Clause 6.6.3.2 of 3GPP TS 36.521-1 v12.6.0).
- For 20 MHz bandwidth, the minimum requirements are specified for E-UTRA UL carrier frequencies confined to either 713–723 MHz or 728–738 MHz.
- For 20 MHz bandwidth, the minimum requirements are specified for E-UTRA UL carrier frequencies confined to either 673–678 MHz or 683–688 MHz.

3.7 Conducted Rx Sensitivity/Tx Power

Note: Values in the following tables are preliminary, pending transceiver matching / testing.

Table 3-3: Typical Conducted Rx (Receive) Sensitivity — LTE Bands at 10 MHz BW^{a,b}

LTE bands	Conducted Rx sensitivity (dBm) ^{c,d}			
	Primary (Typ)	Secondary (Typ)	SIMO (Typ)	SIMO ^e (Worst Case)
B1	-97.0	-97.5	-100.0	-96.3
B2	-98.0	-97.5	-100.5	-94.3
B3	-97.0	-98.0	-100.5	-93.3
B4	-97.0	-98.0	-100.0	-96.3
B5	-99.0	-100.5	-102.5	-94.3
B7	-97.0	-99.0	-101.0	-94.3
B8	-98.5	-100.5	-102.5	-93.3
B12	-97.0	-98.5	-100.5	-95.3
B13	-98.0	-101.0	-102.5	-93.3
B14	-98.0	-101.0	-103.0	-93.3
B18	-97.5	-100.0	-102.0	-93.3

Table 3-3: Typical Conducted Rx (Receive) Sensitivity — LTE Bands at 10 MHz BW^{a,b} (Continued)

LTE bands	Conducted Rx sensitivity (dBm) ^{c,d}			
	Primary (Typ)	Secondary (Typ)	SIMO (Typ)	SIMO ^e (Worst Case)
B19	-99.0	-101.0	-103	-96.3
B20	-98.5	-100.5	-102.5	-96.3
B25	-98.5	-98.5	-103.5	-93.3
B26	-99.0	-100.5	-102.5	-93.8
B28	-97.0	-101.0	-102.5	-93.3
B29	-97.0	-99.0	-101.0	-95.3
B32	-97.0	-98.0	-101.5	-96.3
B38	-97.0	-98.0	-100.5	-94.3
B39	-97.0	-98.5	-101.0	-95.0
B40	-97.0	-97.5	-101.0	-95.0
B41	-97.0	-98.0	-101.0	-95.3
B42	-97.0	-98.0	-100.0	-95.8
B43	-97.0	-97.0	-99.0	-88.5
B48	-97.0	-97.5	-100.0	-96.3
B66	-97.0	-98.0	-100.0	-95.8
B71	-100.0	-97.0	-101.0	-93.5
B106 ^b	-102.0	-103.0	-105.5	-99.2

- a. Full RB on downlink
- b. B106 BW = 3 MHz
- c. Sensitivity values scale with bandwidth: $x_MHz_Sensitivity = 10_MHz_Sensitivity - 10 \cdot \log(10\text{ MHz}/x_MHz)$ Note: Bandwidth support is dependent on firmware version.
- d. Results at room temperature. Based on Lab test result and Call box only in a shielded test environment, and the test is based on standalone mode only.
- e. Per 3GPP specification

Table 3-4: Conducted Rx (Receive) Sensitivity — UMTS Bands

UMTS bands		Conducted Rx sensitivity (dBm)		
		Primary (Typical) ^a	Secondary (Typical)	Primary / Secondary (Worst case) ^b
Band 1	0.1% BER 12.2 kbps	-109.5	-110.5	-106.6
Band 2		-111.2	-110.4	-104.7
Band 4		-109.5	-110.5	-106.5
Band 5		-111.4	-112.3	-104.6
Band 6		-111.2	-112.3	-106.4
Band 8		-111.4	-112.5	-103.7
Band 9		-110.1	-110.9	-105.4
Band 19		-111.1	-112.2	-106.5

- a. The typical result is at room temperature and based on Lab test result and Call box only at a shielded test environment.
b. Per 3GPP specification

Table 3-5: Conducted Tx (Transmit) Power^a Tolerances

Bands	Conducted Tx Power	Notes
LTE		
LTE bands 1, 2, 3, 4, 5, 7, 8, 12, 13, 14, 18, 19, 20, 25, 26, 28, 38, 40, 41, 66, 71, 106	+23 dBm \pm 1 dB	Connectorized (Power Class 3)
LTE band 39	+20 dBm \pm 1 dB	
LTE bands 42, 43, 48	+22 dBm \pm 1 dB	
UMTS		
UMTS bands 1, 2, 4, 5, 6, 8, 9, 19	+23 dBm \pm 1 dB	12.2 kbps Connectorized (Power Class 3)

- a. Tx Power is based on no maximum power reduction (MPR) configuration as 3GPP defined. For configurations that require MPR or additional MPR, refer to 3GPP for the power reduction.

3.8 GNSS Specifications

Note: For detailed electrical performance criteria, see [Recommended GNSS Antenna Specifications](#) on page 68.

Table 3-6: GNSS Specifications

Parameter/feature	Description
Satellite channels	Maximum 54 channels (16 GPS, 14 GLONASS, 12 Galileo, 12 BeiDou), simultaneous tracking
Protocols	NMEA 0183 V3.0 ^a

Table 3-6: GNSS Specifications (Continued)

Parameter/feature	Description
Acquisition time ^b	Hot start: 1 s Warm start: 29 s Cold start: 32 s
Accuracy	Horizontal: < 2 m (50%); < 5 m (90%) Altitude: < 4 m (50%); < 8 m (90%) Velocity: < 0.2 m/s
Sensitivity	Tracking ^c : -161 dBm Acquisition (Assisted) ^d : -158 dBm Acquisition (Standalone): -147 dBm
Operational Limits	Altitude < 6000 m or velocity < 100 m/s (Either limit may be exceeded, but not both.)

- a. NMEA 0183 V4.11 will be supported in a future release.
- b. Acquisition times measured with signal strength = -135 dBm.
- c. Tracking sensitivity is the lowest GNSS signal level in which the device can still detect in-view satellites and get fixed at least 50% of the time when in sequential tracking mode.
- d. Acquisition sensitivity is the lowest GNSS signal strength for which the device can still detect in-view satellites at least 50% of the time.

The module includes an internal GNSS LNA, as shown in [Figure 2-3](#) on page 21.

4: Power

4.1 Power Consumption

Power consumption measurements in the tables below are for the EM759X connected to the host PC via USB.

The module does not have its own power source and depends on the host device for power. For a description of input voltage requirements, see [Power Supply](#) on page 27.

Table 4-1: Averaged Standby DC Power Consumption^a

Signal	Description	Bands ^b	Current ^c			Notes / configuration
			Typ	Max	Unit	
VCC	Standby current consumption (Sleep mode activated ^d)					
	LTE	LTE bands	3.1	3.4	mA	DRX cycle = 8 (2.56 s)
	HSPA / WCDMA	UMTS bands	3.1	3.4	mA	DRX cycle = 8 (2.56 s)
	Standby current consumption ^e (Sleep mode deactivated ^d)					
	LTE	LTE bands	37	42	mA	DRX cycle = 8 (2.56 s)
	HSPA / WCDMA	UMTS bands	37	42	mA	DRX cycle = 8 (2.56 s)
	Low Power Mode (LPM) / Offline Mode ^e (Sleep mode activated ^d)					
	RF disabled, but module is operational		2.6	2.9	mA	
	Low Power Mode (LPM) / Offline Mode ^e (Sleep mode deactivated ^d)					
	RF disabled, but module is operational		37	40	mA	

a. Preliminary, subject to change.

b. For supported bands, see [Table 3-1, Supported Frequency Bands, by RAT \(LTE/3G\)](#), on page 41.

c. Measured at 25°C / nominal 3.3 V voltage.

d. Assumes USB bus is fully suspended during measurements

e. LPM and standby power consumption will increase when LEDs are enabled. To reduce power consumption, configure LEDs to remain off while in standby and LPM modes.

Table 4-2: Averaged Call Mode DC Power Consumption

Description	Tx power (dBm)	Current ^a (mA)		Notes
		Typ	Unit	
LTE ^b	0	568	mA	3CA, 20 MHz+20 MHz+20 MHz BW ^c
		490	mA	3CA, 10 MHz+10 MHz+10 MHz BW ^c
		315	mA	2CA, 20 MHz+20 MHz BW
		285	mA	2CA, 10 MHz+10 MHz BW
		266	mA	Single carrier, 20 MHz BW
		235	mA	Single carrier, 10 MHz BW
	20	1145	mA	3CA, 20 MHz+20 MHz+20 MHz BW ^c
		958	mA	3CA, 10 MHz+10 MHz+10 MHz BW ^c
		866	mA	2CA, 20 MHz+20 MHz BW
		840	mA	2CA, 10 MHz+10 MHz BW
		740	mA	Single carrier, 20 MHz BW
		720	mA	Single carrier, 10 MHz BW
	23	1247	mA	3CA, 20 MHz+20 MHz+20 MHz BW ^c
		1075	mA	3CA, 10 MHz+10 MHz+10 MHz BW ^c
		1023	mA	2CA, 20 MHz+20 MHz BW
		1000	mA	2CA, 10 MHz+10 MHz BW
		906	mA	Single carrier, 20 MHz BW
		890	mA	Single carrier, 10 MHz BW
DC-HSPA/HSPA	0	220	mA	All speeds
	20	720	mA	All speeds
	23	980	mA	Worst case
Peak current (averaged over 100 μs)		2.3	A	All LTE/WCDMA bands

- a. Measured at 25°C/nominal 3.3 V voltage
- b. LTE UL/DL RB = Full, middle channel
- c. 3CA combinations are supported only for EM7595

Table 4-3: Miscellaneous DC Power Consumption

Signal	Description	Current / Voltage				Notes / Configuration
		Min	Typ	Max	Unit	
VCC	Inrush current	—	2.2	2.4	A	<ul style="list-style-type: none"> Assume power supply turn-on time > 100 μs Dependent on host power supply rise time.
	Peak current	—	—	2.5	A	<ul style="list-style-type: none"> Across all bands, all temperature ranges 3.3 V supply
	Leakage current	90	—	120	μ A	<ul style="list-style-type: none"> Module is powered off. Full_Card_Power_Off# is Low, and VCC is supplied.
GNSS Signal connector	Active bias on GNSS port	—	—	100	mA	Voltage applied to the GNSS antenna to power electronics inside the antenna (GNSS RF connector in Figure 3-1)
		3.0	3.10	3.25	V	

Warning: The maximum RF power level allowable on any RF port is +10dBm—damage may occur if this level is exceeded.

4.2 Module Power States

The module has five power states, as described in [Table 4-4](#).

Table 4-4: Module Power States

State	Details	Host is powered	USB interface active	RF enabled
Normal (Default state)	<ul style="list-style-type: none"> Module is active Default state. Occurs when VCC is first applied, Full_Card_Power_Off# is deasserted (pulled high), and W_DISABLE# is deasserted Module is capable of placing/receiving calls, or establishing data connections on the wireless network Current consumption is affected by several factors, including: <ul style="list-style-type: none"> Radio band being used Transmit power Receive gain settings Data rate 	✓	✓	✓

Table 4-4: Module Power States (Continued)

State	Details	Host is powered	USB interface active	RF enabled
Low power (Airplane mode)	<ul style="list-style-type: none"> ▪ Module is active ▪ Module enters this state: <ul style="list-style-type: none"> • Under host interface control: <ul style="list-style-type: none"> • Host issues AT+CFUN=0 ([4] AT Command Set for User Equipment (UE) (Release 6) (Doc# 3GPP TS 27.007)), or • Host asserts W_DISABLE#, after AT!PCOFFEN=0 has been issued. • Automatically, when critical temperature or voltage trigger limits have been reached. 	✓	✓	✗
Sleep	<ul style="list-style-type: none"> ▪ Normal state of module between calls or data connections ▪ Module cycles between wake (polling the network) and sleep, at network provider-determined interval. 	✓	✗	✗
Off	<ul style="list-style-type: none"> ▪ Host keeps module powered off by asserting Full_Card_Power_Off# (signal pulled low or left floating) ▪ Module draws minimal current ▪ See Full_Card_Power_Off# and RESET# on page 35 for more information. 	✓	✗	✗
Disconnected	<ul style="list-style-type: none"> ▪ Host power source is disconnected from the module and all voltages associated with the module are at 0 V. 	✗	✗	✗

4.2.1 Power State Transitions

The module uses state machines to monitor supply voltage and operating temperature, and notifies the host when critical threshold limits are exceeded. (See Table 4-5 for trigger details and Figure 4-1 for state machine behavior.)

Power state transitions may occur:

- Automatically, when critical supply voltage or module temperature trigger levels are encountered.
- Under host control, using available AT commands in response to user choices (for example, opting to switch to airplane mode) or operating conditions.

Table 4-5: Power State Transition Default Trigger Levels

Transition	Voltage		Temperature ^a			Notes
	Trigger	V	Trigger	By CPU	By PA	
				°C	°C	
Normal to Low Power	VOLT_HI_CRIT	4.4	TEMP_LO_CRIT	-40	-40	RF activity suspended
	VOLT_LO_CRIT	3.135	TEMP_HI_CRIT	107	110	

Table 4-5: Power State Transition Default Trigger Levels (Continued)

Transition	Voltage		Temperature ^a			Notes
			Trigger	By CPU	By PA	
	Trigger	°C		°C		
Low Power to Normal	VOLT_HI_NORM	4.3	TEMP_LO_NORM	-29	-29	RF activity resumed
Low Power to Normal or Remain in Normal (Remove warnings)	VOLT_LO_NORM	3.3	TEMP_HI_NORM	75	70	
Normal (Issue warning)	VOLT_LO_WARN	3.2	TEMP_HI_WARN	85	80	In the TEMP_HI_WARN state, the module may have reduced performance (Class B temperature range).

a. Module-reported temperatures at the printed circuit board.

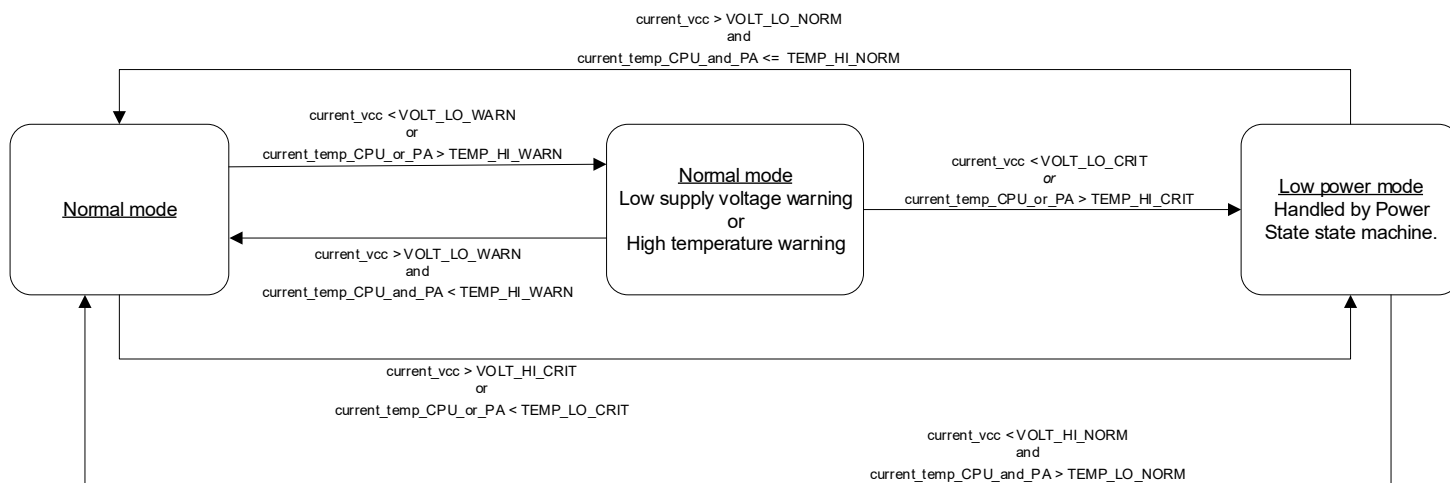

Figure 4-1: Voltage/Temperature Monitoring State Machines

4.3 Power Interface

4.3.1 Power Ramp-up

On initial power up, inrush current depends on the power supply rise time — turn on time > 100 μs is required for < 3 A inrush current.

The supply voltage must remain within specified tolerances while this is occurring.

4.3.2 Timing

4.3.2.1 Power On/Off Timing for USB Port

Figure 4-2 describes the timing sequence for powering the module on and off.

Note: Before reaching the “Active” state, signals on the host port are considered to be undefined and signal transitions may occur. This undefined state also applies when the module is in reset mode, during a firmware update, or during the Power-off sequence. The host must consider these undefined signal activities when designing the module interface.

Note: The host should not drive any signals to the module until > 100 ms from the start of the power-on sequence.

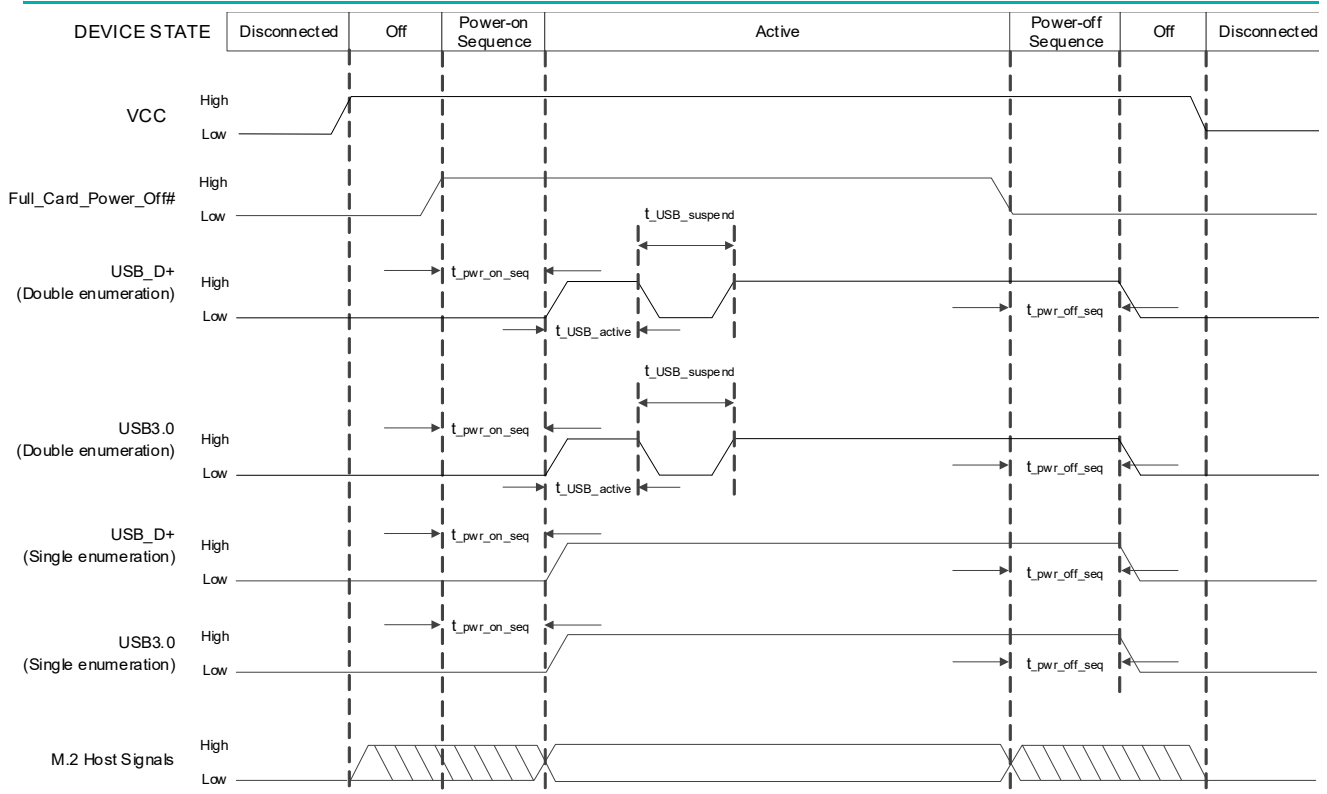

Figure 4-2: Signal Timing (Full_Card_Power_Off#, and USB Enumeration)

Table 4-6: USB 2.0 Power-On / Off Timing Parameters (Single Enumeration)

Symbol	Parameter	Typ	Max	Unit
$t_{pwr_on_seq}$	Power on sequence time	17.64	18	s
$t_{pwr_off_seq}$	Power off sequence time	10.5	12	s

Table 4-7: USB 3.0 Power-On / Off Timing Parameters (Single Enumeration)

Symbol	Parameter	Typ	Max	Unit
t_pwr_on_seq	Power on sequence time	17.38	18	s
t_pwr_off_seq	Power off sequence time	10.5	12	s

Table 4-8: USB 2.0 Power-On / Off Timing Parameters (Double Enumeration)

Symbol	Parameter	Typ	Max	Unit
t_pwr_on_seq	Power on sequence time	1.29	1.31	s
t_USB_active	First enumeration duration	0.07	0.12	s
t_USB_suspend	Duration between enumerations	16.17	17	s
t_pwr_off_seq	Power off sequence time	10.5	12	s

Table 4-9: USB 3.0 Power-On / Off Timing Parameters (Double Enumeration)

Symbol	Parameter	Typ	Max	Unit
t_pwr_on_seq	Power on sequence time	1.02	1.1	s
t_USB_active	First enumeration duration	0.20	0.22	s
t_USB_suspend	Duration between enumerations	16.11	17	s
t_pwr_off_seq	Power off sequence time	10.5	12	s

4.3.2.2 USB Enumeration

The unit supports single and double USB enumeration with the host, as shown in [Figure 4-2](#):

- Single enumeration:
 - Enumeration starts within maximum t_pwr_on_seq seconds of power-on.
- Double enumeration
 - First enumeration starts within t_pwr_on_seq seconds of power-on.
 - Second enumeration starts after t_USB_suspend.

For examples of USB 2.0 and USB 3.0 double enumeration sequences, see [Figure 4-3](#) and [Figure 4-4](#) below. Note that these are sketch diagrams of timing trends for reference purposes only. To verify actual USB performance, it is recommended to use an oscilloscope with the USB Protocol Analyzer).

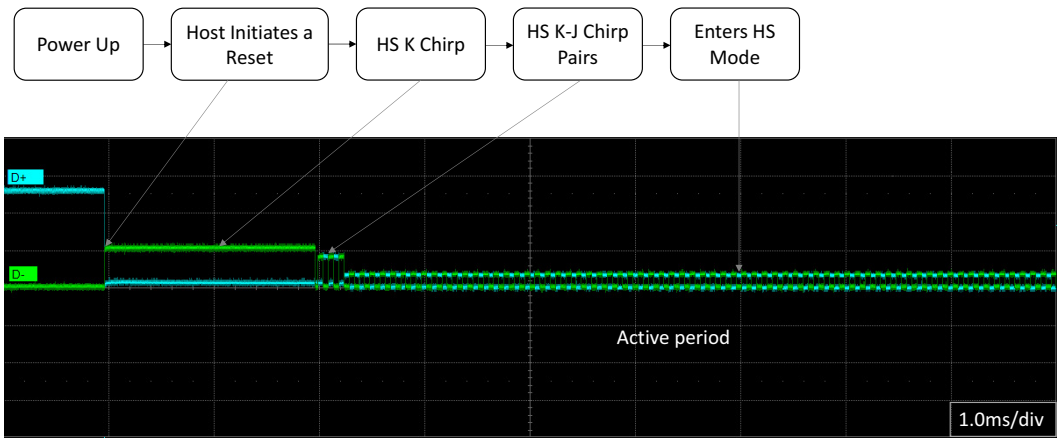

Figure 4-3: USB 2.0 Double Enumeration — Example Sequence Waveform

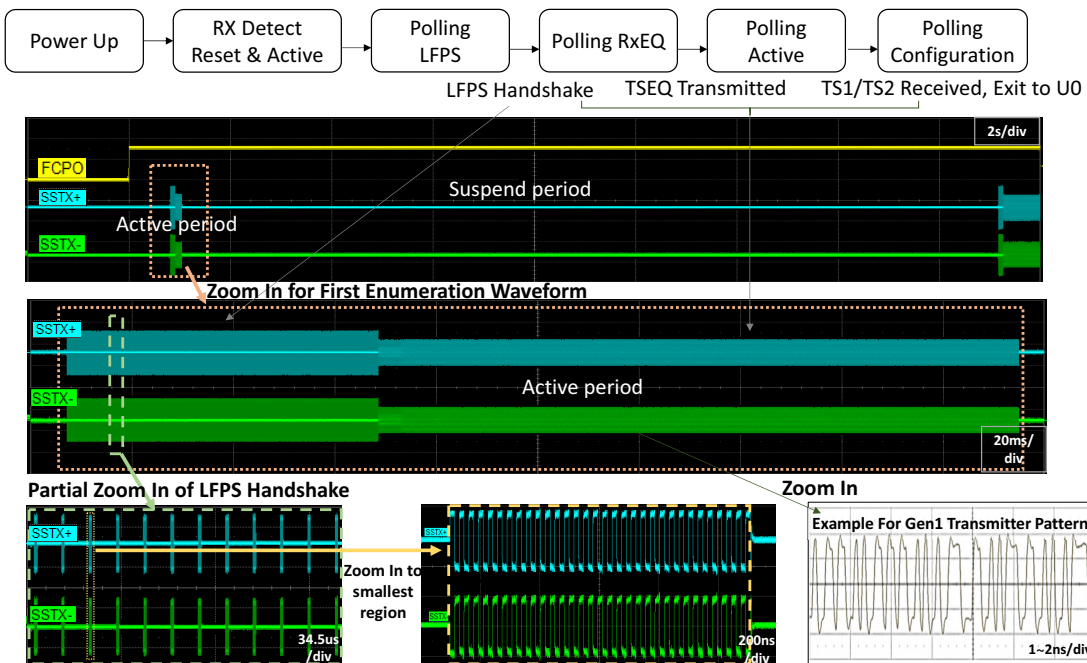

Figure 4-4: USB 3.0 Double Enumeration — Example Sequence Waveform

4.3.2.3 Reset Timing

To reset the module, see [Table 2-7](#) on page 35 for RESET# signal usage instructions.

[Figure 4-5](#) on page 55 describes the reset timing for the following cases:

- Case 1 — The host triggers RESET# and releases in < 400 ms. Nothing happens.
- Case 2 — The host triggers RESET# and releases in 400 ms to 9 s. A software reset occurs.
- Case 3 — The host triggers RESET# and releases anytime after ~12 s. A graceful shutdown starts after 9 s and completes by ~12 s. The module restarts when RESET# is released any time after the shutdown completes.
- Case 4 — The host triggers RESET# and releases between 9 s to ~12 s. A graceful shutdown starts after 9 s and, when RESET# is released before 12 s, either the module restarts (because the graceful shutdown had completed), or a software reset occurs.
- Case 5 — The module’s firmware hangs before or up to 400 ms after the host triggers RESET#, and the host releases RESET# any time after 2 s. A hardware reset occurs.

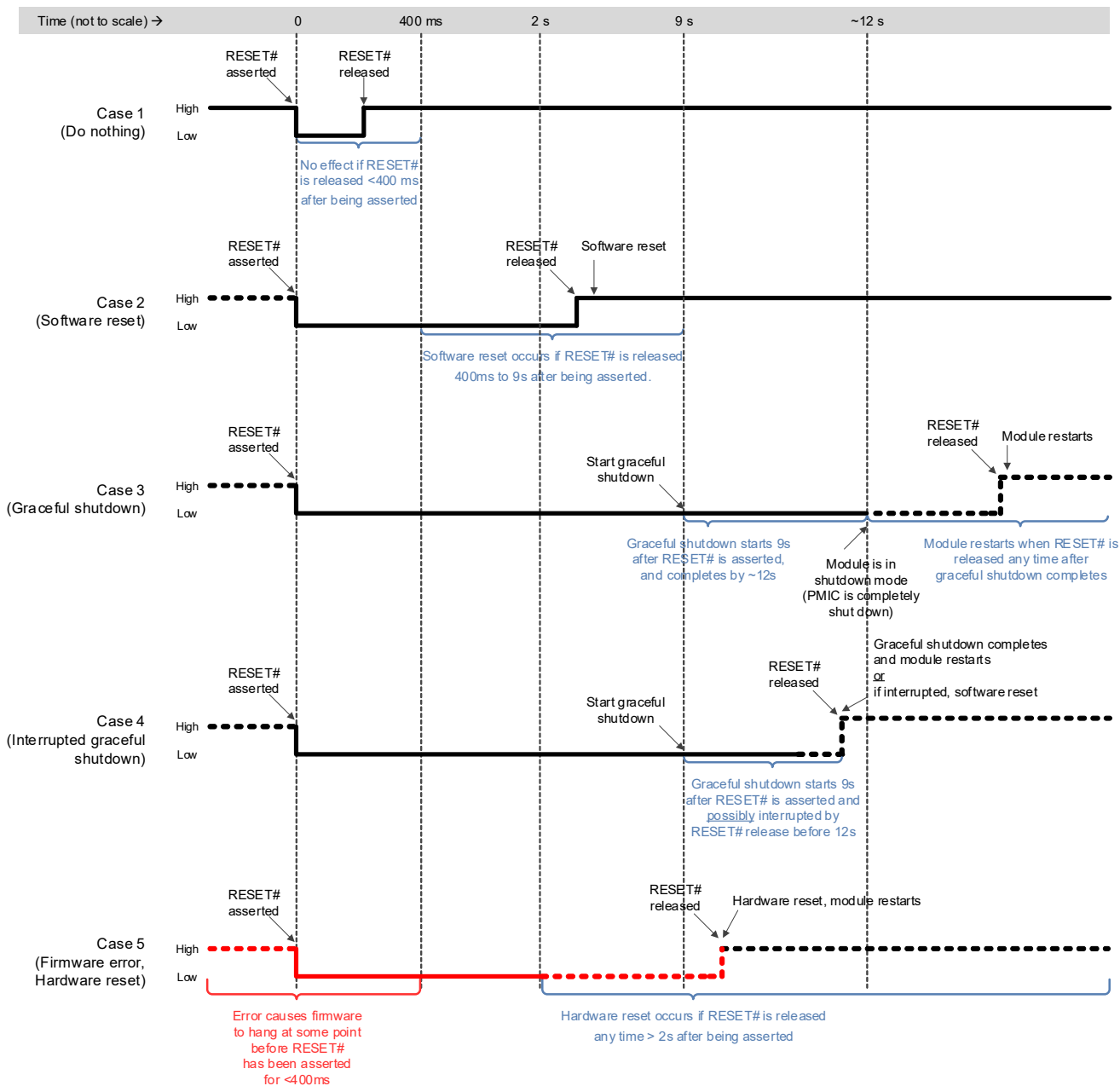

Figure 4-5: Signal Timing (RESET#)

4.3.2.4 Required Shutdown Sequence

Warning: To avoid causing issues with the file system, follow this shutdown sequence.

To safely power off the module:

1. Drive Full_Card_Power_Off# low.
2. Wait for at least t_pwr_off_seq seconds.
3. Remove power.

4.3.3 Power Supply Noise

Noise in the power supply can lead to noise in the RF signal.

The power supply ripple limit for the module is no more than 100 mVp-p, 1–100 kHz. This limit includes voltage ripple due to transmitter burst activity.

Additional decoupling capacitors can be added to the main VCC line to filter noise into the device.

4.4 SED (Smart Error Detection)

The module uses a form of SED to track premature module resets.

- The module tracks consecutive resets occurring soon after power-on.
- After a fifth consecutive reset, the module waits in boot-and-hold mode for a firmware download to resolve the power-cycle problem.

4.5 Tx Power Control

The module’s Tx power limit may be controlled using either SAR backoff AT commands, defined in [1] *Sierra Wireless EM759X AT Command Reference (Doc# 41114426)*, or the DPR (Dynamic power control) signal. Use the GPIOARENABLE parameter for !CUSTOM to choose the method:

- AT commands:
 - !SARSTATEDFLT— Set (or report) the default SAR backoff state that the device uses when it powers up. This setting is persistent across power cycles and overrides any PRI setting.
 - !SARSTATE— Set (or report) the current SAR backoff state (override the default state). This change in state is non-persistent across power cycles.

Note: A customization is available to invert the DPR logic. (e.g. make DPR low = No SAR backoff)

- Dynamic power control— The module’s firmware monitors DPR (pin 25) and adjusts the RF Tx power appropriately, as detailed in [Table 4-10](#). (This state change is equivalent to issuing the !SARSTATE AT command.)

Table 4-10: Dynamic Power Control of SAR Backoff State

DPR	SAR Backoff State
High ^a	No SAR backoff
Low	Backoff 1

a. DPR is pulled high by default.

Note: The host can implement an open collector drive for the DPR pin (if a 1.8 V-compatible drive is not available).

5: Software

5.1 Support Tools

The EM759X is compatible with the following support tools from Sierra Wireless and authorized third parties:

- Firmware update utilities (Windows, Linux)
- Modem Logger (Windows, Linux)
- Win Logger tool (Windows)
- Windows Driver Package
- MBIMAT (Windows)
- RAM dump tool (Windows, Linux)
- QXDM from Qualcomm
- Qualcomm Product Support Tool (QUTS)

5.2 Host Interface

The device supports the following protocols for modem communication:

- MBIM (Mobile Broadband Interface Model)
- Qualcomm QMI interface. (Please contact your Semtech account representative for QMI interface documentation.)

Mobile Broadband Packages are available for the EM759X modules on the specific device pages at source.sierrawireless.com.

6: Mechanical and Environmental Specifications

EM759X modules comply with the mechanical and environmental specifications in [Table 6-1](#). Final product conformance to these specifications depends on the [OEM](#) device implementation.

Table 6-1: Mechanical and Environmental Specifications

	Mode	Details
Ambient temperature	Operational Class A	-30°C to +70°C — 3GPP compliant, with host application-appropriate heatsinking
	Operational Class B	-40°C to +85°C, with host application-appropriate heatsinking — non-3GPP compliant (reduced operating parameters required)
	Storage	-40°C to +85°C (at up to 85% RH, non-condensing)
Humidity test	15 minutes Idle / 15 minutes Off	Test temperature: 85°C Relative humidity: 85% Stress duration: 10 days
Vibration	Non-operational	Random vibration, 10 to 2000 Hz, 0.1 g ² /Hz to 0.0005 g ² /Hz, in each of three mutually perpendicular axes. Test duration of 60 minutes for each axis, for a total test time of three hours.
Shock	Non-operational	Half sine shock, 11 ms, 30 g, 8x each axis Half sine shock, 6 ms, 100 g, 3x each axis
Drop	Non-operational	1 m on concrete on each of six faces, two times (module only)
Electrostatic Discharge (See Electrostatic Discharge (ESD) on page 61.)	Operational	The RF port (antenna launch and RF connector) complies with the IEC 61000-4-2 standard: <ul style="list-style-type: none"> Electrostatic discharge immunity: Test Level 3 Air discharge: ±8 kV
	Non-operational	The host connector interface complies with the following standard only: <ul style="list-style-type: none"> Minimum ±500 V Human Body Model (JESD22-A114-B)
Thermal considerations		See Thermal Considerations on page 61
Form factor		M.2 Form Factor
Dimensions		Length: 42±0.10 mm (max) Width: 30±0.10 mm (max) Thickness: 2.38 mm (max) Above PCB — 1.50 mm (max) PCB — 0.88 mm (max) Weight: 6.5 g (max)

6.1 Device Views

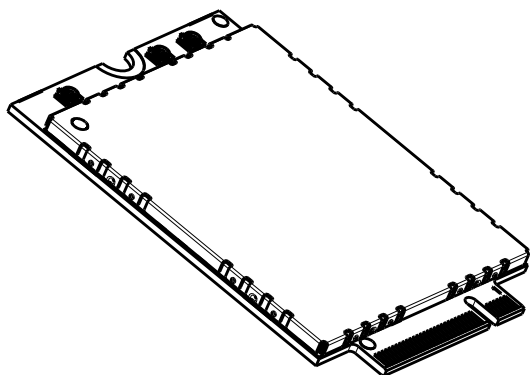
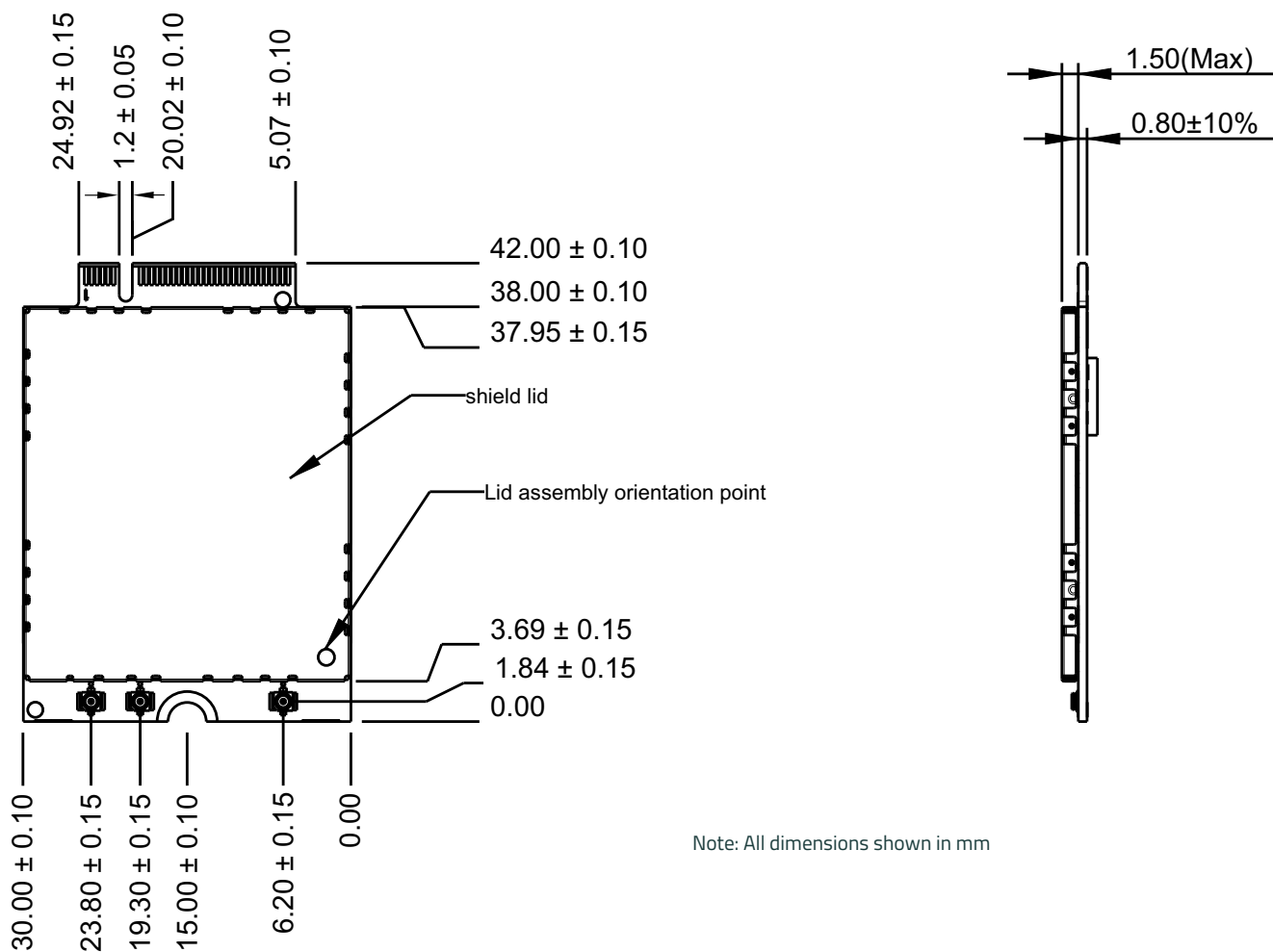

Figure 6-1: Top View



Note: All dimensions shown in mm

Figure 6-2: Dimensioned View

6.2 Product Marking

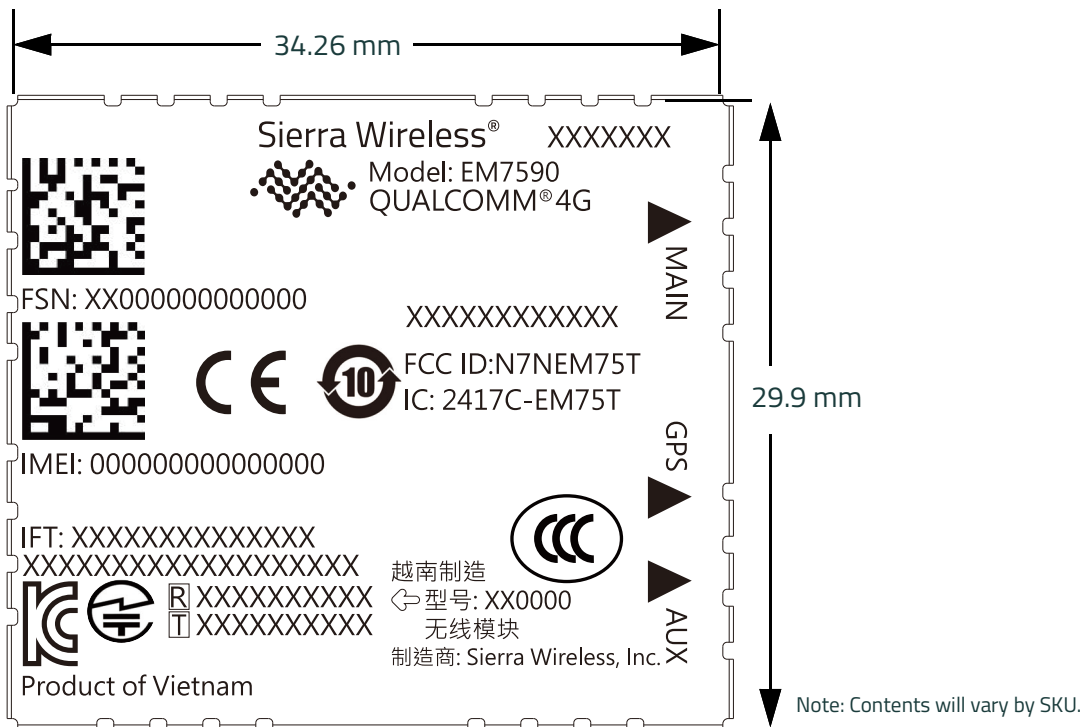

Figure 6-3: EM7590 Unit Product Marking Example — Laser-etched, Typical Representation

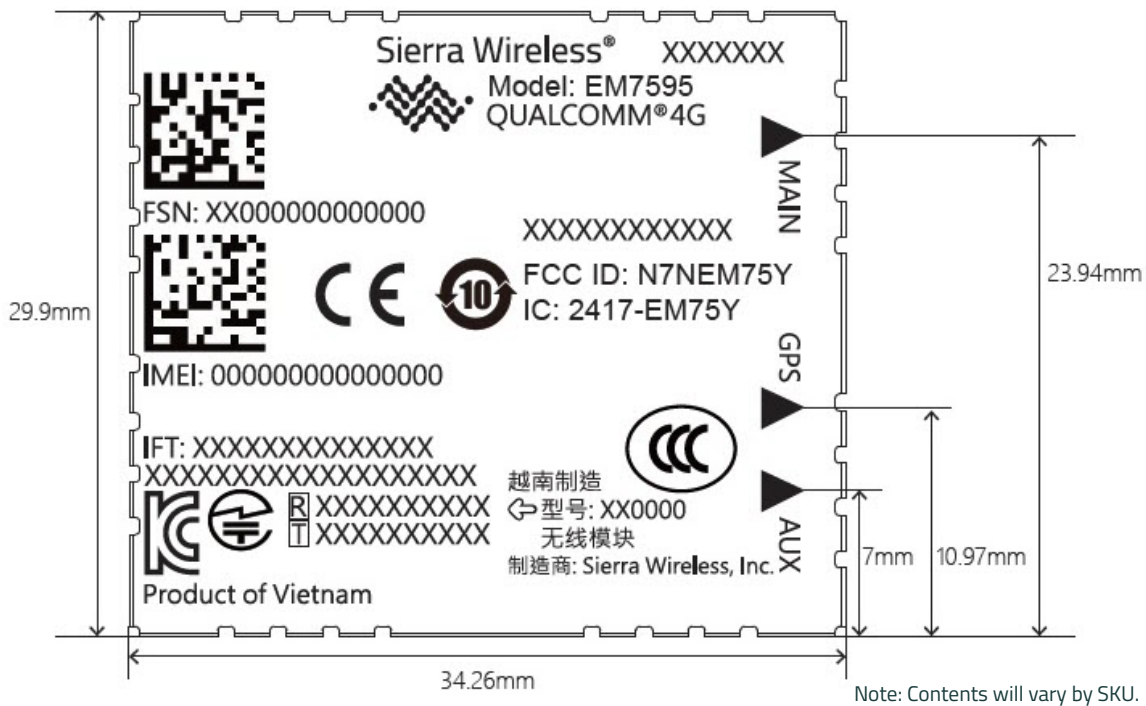

Figure 6-4: EM7595 Unit Product Marking Example — Laser-etched, Typical Representation

The EM759X module's product marking is laser-etched and may contain:

- Sierra Wireless logo and product name
- IMEI number in Data Matrix barcode format
- SKU number (when required)
- Factory Serial Number (FSN) in alphanumeric format
- Manufacturing date code (incorporated into FSN)
- Licensed vendor logo
- Certification marks / details

Note: The EM759X supports OEM partner-specific label requirements.

6.3 Electrostatic Discharge (ESD)

The OEM is responsible for ensuring that the EM759X module's host interface pins are not exposed to ESD during handling or normal operation. (See [Table 6-1](#) on page 58 for specifications.)

ESD protection is highly recommended for the SIM connector at the point where the contacts are exposed, and for any other signals from the host interface that would be subjected to ESD by the user of the product. (The device includes ESD protection on the antenna.)

6.4 Thermal Considerations

Embedded modules can generate significant amounts of heat that must be dissipated in the host device for safety and performance reasons.

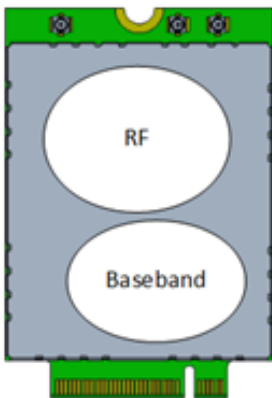

Figure 6-5: Shield Locations (Top View)

The amount of thermal dissipation required depends on:

- Supply voltage — Maximum power dissipation for the module can be up to 4.7 W at voltage supply limits.
- Usage — Typical power dissipation values depend on the location within the host, amount of data transferred, etc.

Specific areas requiring heat dissipation are shown in [Figure 6-6](#):

- RF — Bottom face of module near RF connectors. Likely to be the hottest area.
- Baseband — Bottom face of module, below the baseband area.

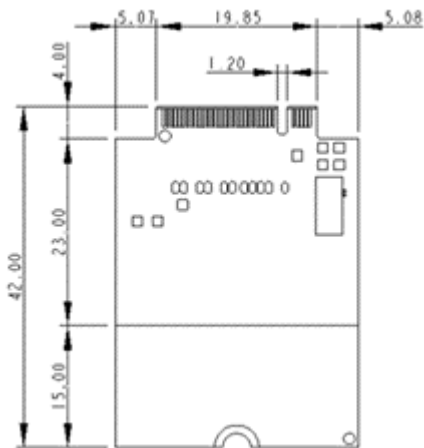

Figure 6-6: Copper Pad Location on Bottom Side of Module

To enhance heat dissipation:

- It is recommended to add a heat sink that mounts the module to the main PCB or metal chassis (a thermal compound or pads must be used between the module and the heat sink).
- Maximize airflow over / around the module.
- Locate the module away from other hot components.
- Module ground holes must be used to attach (ground) the device to the main PCB ground or a metal chassis.
- You may also need active cooling to pull heat away from the module.

Note: Adequate dissipation of heat is necessary to ensure that the module functions properly. Refer to [3] EM759X Thermal Mitigation Guide (Doc# 2174324) for more details.

6.5 Module Integration Testing

When testing your integration design:

- Test to your worst case operating environment conditions (temperature and voltage)
- Test using worst case operation (transmitter on 100% duty cycle, maximum power)
- Monitor temperature at all shield locations. Attach thermocouples to the areas indicated in [Figure 6-6](#) (RF, Baseband).

Note: Make sure that your system design provides sufficient cooling for the module.

(For acceptance, certification, quality and production (including RF) test suggestions, see [Testing](#) on page 75.)

7: Regulatory Compliance and Industry Certifications

This chapter describes the current certification status of the EM7590 and EM7595 (hereinafter collectively referred to as “EM759X”). Certifications in other countries may be attained upon customer request—contact your Semtech account representative for details.

Additional testing and certification may be required for the host product with an embedded EM759X module and are the responsibility of the OEM. Sierra Wireless offers professional services-based assistance to OEMs with the testing and certification process, if required.

7.1 Regulatory Compliance

The EM759X module meets the requirements of the following regulatory bodies and regulations, where applicable:

- Federal Communications Commission (FCC) of the United States
- Innovation, Science and Economic Development Canada (ISED)
- The National Communications Commission (NCC) of Taiwan, Republic of China
- Japan Ministry of Internal Affairs and Communications (MIC)
- Radio Equipment Directive (RED) of the European Union

7.2 Important Compliance Information for Canada

The EM759X module has been granted modular approval for mobile applications under:

- EM7590: IC: 2417C-EM75T
- EM7595: IC: 2417C-EM75Y

Integrators may use the EM759X module in their host products without additional ISED certification if they meet the following conditions. Otherwise, additional ISED approvals must be obtained.

1. At least 20 cm separation distance between the antenna and the user’s body must be maintained at all times.
2. To comply with ISED regulations limiting both maximum RF output power and human exposure to RF radiation, the maximum antenna gain including cable loss in a mobile-only exposure condition must not exceed the limits stipulated in [Table 7-1](#) on page 63.
3. The EM759X module may transmit simultaneously with other collocated radio transmitters within a host product, provided the following conditions are met:
 - Each collocated radio transmitter has been certified by ISED for mobile application.
 - At least 20 cm separation distance between the antennas of the collocated transmitters and the user’s body must be maintained at all times.
 - The radiated power of a collocated transmitter must not exceed the EIRP limit stipulated in [Table 7-1](#).

Table 7-1: ISED Antenna Gain and Collocated Radio Transmitter Specifications

	Operating mode	Tx Freq Range (MHz)		Antenna Gain Limit (dBi)	
				Standalone	Collocated
EM759X	WCDMA Band 2, LTE B2	1850	1910	9.00	7.30
	WCDMA Band 4, LTE B4	1710	1755	6.00	6.00

Table 7-1: ISED Antenna Gain and Collocated Radio Transmitter Specifications (Continued)

	Operating mode	Tx Freq Range (MHz)		Antenna Gain Limit (dBi)	
				Standalone	Collocated
	WCDMA Band 5, LTE B5	824	849	7.00	4.90
	LTE B7	2500	2570	9.00	8.20
	LTE B12	699	716	6.60	4.50
	LTE B13	777	787	6.90	4.80
	LTE B14	788	798	6.90	4.80
	LTE B25	1850	1915	9.00	7.30
	LTE B26	814	849	7.00	4.90
	LTE B41	2496	2690	9.00	8.20
	LTE B42	3450	3600	0.00	0.00
	LTE B43	3600	3800	0.00	0.00
	LTE B48	3550	3700	0.00	0.00
	LTE B66	1710	1780	6.00	6.00
	LTE B71	663	698	6.40	4.30
Collocated transmitters				Maximum EIRP (dBm)	
	WLAN 2.4 GHz	2400	2500	30	
	WLAN 5 GHz	5150	5850	30	
	WLAN 6 GHz	5955	7115	30	
	Bluetooth	2400	2500	16	

4. A label must be affixed to the outside of the end product into which the EM759X module is incorporated, with a statement similar to the following:
 - (EM7590) **This device contains IC: 2417C-EM75T.**
 - (EM7595) **This device contains IC: 2417C-EM75Y.**
5. A user manual with the end product must clearly indicate the operating requirements and conditions that must be observed to ensure compliance with current ISED RF exposure guidelines.

Note: Host product manufacturers are responsible for the overall compliance of the host products including, where applicable, all additional equipment authorization and testing not covered by the modular approval (e.g., ISED’s Interference-Causing Equipment Standards, and RF exposure requirements for host products intended for use within 20 cm of the user’s body.)

7.3 Important Compliance Information for the United States

The EM759X module has been granted modular approval for mobile applications under:

- EM7590: FCC ID: N7NEM75T
- EM7595: FCC ID: N7NEM75Y

Integrators may use the EM759X module in their host products without additional FCC certification if they meet the following conditions. Otherwise, additional FCC approvals must be obtained.

1. At least 20 cm separation distance between the antenna and the user’s body must be maintained at all times.
2. To comply with FCC regulations limiting both maximum RF output power and human exposure to RF radiation, the maximum antenna gain including cable loss in a mobile-only exposure condition must not exceed the limits stipulated in [Table 7-2](#) on page 65.
3. The EM759X module may transmit simultaneously with other collocated radio transmitters within a host product, provided the following conditions are met:
 - Each collocated radio transmitter has been certified by FCC for mobile application.
 - At least 20 cm separation distance between the antennas of the collocated transmitters and the user’s body must be maintained at all times.
 - The radiated power of a collocated transmitter must not exceed the EIRP limit stipulated in [Table 7-2](#).

Table 7-2: FCC Antenna Gain and Collocated Radio Transmitter Specifications

	Operating mode	Tx Freq Range (MHz)		Antenna Gain Limit (dBi)	
				Standalone	Collocated
EM759X	WCDMA Band 2, LTE B2	1850	1910	9.00	7.30
	WCDMA Band 4, LTE B4	1710	1755	6.00	6.00
	WCDMA Band 5, LTE B5	824	849	7.00	4.90
	LTE B7	2500	2570	9.00	8.20
	LTE B12	699	716	6.60	4.50
	LTE B13	777	787	6.90	4.80
	LTE B14	788	798	6.90	4.80
	LTE B25	1850	1915	9.00	7.30
	LTE B26	814	849	7.00	4.90
	LTE B41	2496	2690	9.00	8.20
	LTE B48*	3550	3700	0.00	0.00
	LTE B66	1710	1780	6.00	6.00
	LTE B71	663	698	6.40	4.30
LTE B106	897.5	900.5	10.70	9.70	
Collocated transmitters				Maximum EIRP (dBm)	
	WLAN 2.4 GHz	2400	2500	30	
	WLAN 5 GHz	5150	5850	30	
	WLAN 6 GHz	5955	7115	30	
	Bluetooth	2400	2500	16	

***Important:** Airborne operations in LTE Band 48 are prohibited.

4. A label must be affixed to the outside of the end product into which the EM759X module is incorporated, with a statement similar to the following:
 - (EM7590) **This device contains FCC ID: N7NEM75T.**
 - (EM7595) **This device contains FCC ID: N7NEM75Y.**
5. A user manual with the end product must clearly indicate the operating requirements and conditions that must be observed to ensure compliance with current FCC RF exposure guidelines.

Note: Host product manufacturers are responsible for the overall compliance of the host products including, where applicable, all additional equipment authorization and testing not covered by the modular approval (e.g., unintentional radiator FCC Part 15 Subpart B requirements, and RF exposure requirements for host products intended for use within 20 cm of the user’s body.)

7.4 Industry Certifications

The EM759X module complies with the mandatory requirements described in the following standards. The exact set of requirements supported is network operator-dependent.

Table 7-3: Standards Compliance

Technology	Standards
LTE	3GPP Release 12 ^a
UMTS	3GPP Release 9

a. Some auxiliary functions support Release 13.

The following industry certifications have been obtained, where applicable:

- GCF
- PTCRB

A: Antenna Specification

This appendix describes recommended electrical performance criteria for main path, diversity path, and GNSS antennas used with Sierra Wireless embedded modules.

The performance specifications described in this section are valid while antennas are mounted in the host device with antenna feed cables routed in their final application configuration.

Note: Antennas should be designed before the industrial design is finished to make sure that the best antennas can be developed.

A.1 Recommended Main / Diversity Antenna Specifications

Table A-1: Antenna Requirements^a

Parameter	Requirements	Comments
Antenna system	(LTE) External multi-band 2x2 MIMO antenna system (Ant1 / Ant2) ^b (3G) External multi-band antenna system with diversity (Ant1 / Ant2) ^c	If Ant2 includes GNSS, then it must also satisfy requirements in Table A-2 on page 68.
Operating bands — Antenna 1	All supporting Tx and Rx frequency bands.	
Operating bands — Antenna 2	All supporting Rx frequency bands, plus GNSS frequency bands if Antenna 2 is used in shared Diversity / MIMO / GNSS mode.	
VSWR of Ant1 and Ant2	<ul style="list-style-type: none"> ▪ < 2:1 (recommended) ▪ < 3:1 (worst case) 	On all bands including band edges
Total radiated efficiency of Ant1 and Ant2	> 50% on all bands	<ul style="list-style-type: none"> ▪ Measured at the RF connector. ▪ Includes mismatch losses, losses in the matching circuit, and antenna losses, excluding cable loss. ▪ Sierra Wireless recommends using antenna efficiency as the primary parameter for evaluating the antenna system. ▪ Peak gain is not a good indication of antenna performance when integrated with a host device (the antenna does not provide omnidirectional gain patterns). Peak gain can be affected by antenna size, location, design type, etc. — the antenna gain patterns remain fixed unless one or more of these parameters change.
Radiation patterns of Ant1 and Ant2	Nominally omni-directional radiation pattern in azimuth plane.	
Envelope correlation coefficient between Ant1 and Ant2	<ul style="list-style-type: none"> ▪ < 0.5 on Rx bands below 960 MHz ▪ < 0.2 on Rx bands above 1.4 GHz 	
Mean Effective Gain — Ant1 (MEG1), Ant2 (MEG2)	≥ -3 dBi	

Table A-1: Antenna Requirements^a (Continued)

Parameter	Requirements	Comments
Ant1 and Ant2 Mean Effective Gain Imbalance $\frac{ MEG1 }{ MEG2 }$	<ul style="list-style-type: none"> < 2 dB for MIMO operation < 6 dB for diversity operation 	
Maximum antenna gain	Must not exceed antenna gains due to RF exposure and ERP/EIRP limits, as listed in the module's FCC and ISED grants.	See Important Compliance Information for Canada on page 63 and Important Compliance Information for the United States on page 64.
Isolation between Ant1 and Ant2 (S21)	> 10 dB	<ul style="list-style-type: none"> If antennas can be moved, test all positions for both antennas. Make sure all other wireless devices (Bluetooth or WLAN antennas, etc.) are turned OFF to avoid interference.
Power handling	> 1 W	<ul style="list-style-type: none"> Measure power endurance over 4 hours (estimated talk time) using a 1 W CW signal— set the CW test signal frequency to the middle of each supporting Tx band. Visually inspect device to ensure there is no damage to the antenna structure and matching components. VSWR/TIS/TRP measurements taken before and after this test must show similar results.

- a. These worst-case VSWR figures for the transmitter bands may not guarantee RSE levels to be within regulatory limits. The device alone meets all regulatory emissions limits when tested into a cabled (conducted) 50 Ω system. With antenna designs with up to 2.5:1 VSWR or worse, the radiated emissions could exceed limits. The antenna system may need to be tuned in order to meet the RSE limits as the complex match between the module and antenna can cause unwanted levels of emissions. Tuning may include antenna pattern changes, phase/delay adjustment, and passive component matching. Examples of the application test limits would be included in FCC Part 22, Part 24 and Part 27, test case 4.2.2 for WCDMA (ETSI EN 301 908-1), where applicable.
- b. Ant1—main RF (Rx/Tx), Ant2—Auxiliary RF (Diversity/MIMO/GNSS)
- c. Ant1—main RF (Rx/Tx), Ant2—Auxiliary RF (Diversity/GNSS)

A.2 Recommended GNSS Antenna Specifications

Table A-2: GNSS Antenna Requirements

Parameter	Requirements	Comments
Frequency range	<ul style="list-style-type: none"> Wide-band GNSS: 1559–1606 MHz recommended Narrow-band GPS: 1575.42 MHz ±2 MHz minimum Narrow-band Galileo: 1575.42 MHz ±2 MHz minimum Narrow-band BeiDou: 1561.098 MHz ±2 MHz minimum Narrow-band GLONASS: 1601.72 MHz ±4.2 MHz minimum Narrow-band QZSS: 1575.42 MHz ±2 MHz minimum 	
Field of view (FOV)	<ul style="list-style-type: none"> Omni-directional in azimuth -45° to +90° in elevation 	

Table A-2: GNSS Antenna Requirements (Continued)

Parameter	Requirements	Comments
Polarization (average Gv/Gh)	> 0 dB	Vertical linear polarization is sufficient.
Free space average gain (Gv+Gh) over FOV	> -6 dBi (preferably > -3 dBi)	Gv and Gh are measured and averaged over -45° to +90° in elevation, and ±180° in azimuth.
Gain	<ul style="list-style-type: none"> ▪ Maximum gain and uniform coverage in the high elevation angle and zenith. ▪ Gain in azimuth plane is not desired. 	
Average 3D gain	> -5 dBi	
Isolation between GNSS and ANT1	> 10 dB in all uplink bands	
Typical VSWR	< 2.5:1	
Polarization	Any other than LHCP (left-hand circular polarized) is acceptable.	

A.3 Antenna Tests

The following guidelines apply to the requirements described in [Table A-1](#) on page 67 and [Table A-2](#) on page 68:

- Perform electrical measurements at room temperature (+20°C to +26°C) unless otherwise specified
- For main and diversity path antennas, make sure the antennas (including contact device, coaxial cable, connectors, and matching circuit with no more than six components, if required) have nominal impedances of 50 Ω across supported frequency bands.
- All tests (except isolation/correlation coefficient)—Test the main or diversity antenna with the other antenna terminated.
- Any metallic part of the antenna system that is exposed to the outside environment needs to meet the electrostatic discharge tests per IEC61000-4-2 (conducted discharge +8 kV).
- The functional requirements of the antenna system are tested and verified while the embedded module's antenna is integrated in the host device.

Note: Additional testing, including active performance tests, mechanical, and accelerated life tests can be discussed with Sierra Wireless' engineering services. Contact your Sierra Wireless representative for assistance.

B: Carrier Aggregations

This appendix indicates the supported downlink (Table B-1, Table B-2) and uplink (Table B-3) carrier aggregation (CA) combinations for EM759X modules.

Table B-1: EM759X Carrier Aggregation (2CC) Downlink Combinations

1 Band / 2 CC		2 Bands / 2CC			
CA_1A-1A	CA_41A-41A	CA_1A-3A	CA_2A-28A	CA_4A-29A	CA_12A-25A
CA_1C	CA_41C	CA_1A-5A	CA_2A-29A	CA_4A-71A	CA_12A-66A
CA_2A-2A	CA_42C	CA_1A-7A	CA_2A-66A	CA_5A-7A	CA_13A-66A
CA_2C	CA_43C	CA_1A-8A	CA_2A-71A	CA_5A-25A	CA_14A-66A
CA_3A-3A	CA_48C	CA_1A-18A	CA_3A-5A	CA_5A-38A	CA_19A-1A
CA_3C	CA_66A-66A	CA_1A-19A	CA_3A-7A	CA_5A-40A	CA_19A-3A
CA_4A-4A	CA_66B	CA_1A-20A	CA_3A-8A	CA_5A-41A	CA_19A-42A
CA_5A-5A	CA_66C	CA_1A-26A	CA_3A-19A	CA_5A-66A	CA_20A-32A
CA_5B	—	CA_1A-28A	CA_3A-20A	CA_7A-8A	CA_20A-40A
CA_7A-7A	—	CA_1A-32A	CA_3A-26A	CA_7A-12A	CA_20A-42A
CA_7B	—	CA_1A-38A	CA_3A-28A	CA_7A-20A	CA_25A-26A
CA_7C	—	CA_1A-40A	CA_3A-38A	CA_7A-28A	CA_26A-41A
CA_8B	—	CA_1A-41A	CA_3A-40A	CA_7A-32A	CA_28A-38A
CA_12A-12A	—	CA_1A-42A	CA_3A-41A	CA_7A-42A	CA_28A-40A
CA_12B	—	CA_2A-4A	CA_3A-42A	CA_8A-32A	CA_28A-41A
CA_25A-25A	—	CA_2A-5A	CA_4A-5A	CA_8A-38A	CA_28A-42A
CA_38C	—	CA_2A-7A	CA_4A-7A	CA_8A-39A	CA_29A-66A
CA_39C	—	CA_2A-12A	CA_4A-12A	CA_8A-40A	CA_39A-41A
CA_40A-40A	—	CA_2A-13A	CA_4A-13A	CA_8A-41A	CA_41A-42A
CA_40C	—	CA_2A-14A	CA_4A-28A	CA_8A-42A	CA_66A-71A

Table B-2: EM7595 Carrier Aggregation (3CC) Downlink Combinations

1 Band / 3 CC	2 Bands / 3CC				3 Bands / 3CC	
CA_40D	CA_1A-1A-5A	CA_3A-3A-28A	CA_5A-40C	CA_38A-40C	CA_1A-3A-5A	CA_2A-7A-12A
CA_41D	CA_1A-1A-7A	CA_3A-3A-41A	CA_5A-48C	CA_39A-41C	CA_1A-3A-7A	CA_2A-12A-66A
CA_42D	CA_1A-1A-28A	CA_3A-7A-7A	CA_5A-66A-66A	CA_39C-41A	CA_1A-3A-8A	CA_2A-13A-48A
CA_48D	CA_1A-3C	CA_3A-7B	CA_5A-66B	CA_40A-40C	CA_1A-3A-19A	CA_2A-13A-66A

Table B-2: EM7595 Carrier Aggregation (3CC) Downlink Combinations (Continued)

1 Band / 3 CC	2 Bands / 3CC				3 Bands / 3CC	
CA_66D	CA_1A-7A-7A	CA_3A-7C	CA_5A-66C	CA_40A-42C	CA_1A-3A-20A	CA_2A-14A-66A
—	CA_1A-7C	CA_3A-38C	CA_5B-66A	CA_40C-42A	CA_1A-3A-26A	CA_2A-66A-71A
—	CA_1A-40C	CA_3A-40A-40A	CA_7A-7A-8A	CA_41A-41C	CA_1A-3A-28A	CA_3A-5A-7A
—	CA_1A-41C	CA_3A-40C	CA_7A-40C	CA_41A-42C	CA_1A-3A-38A	CA_3A-5A-38A
—	CA_1A-42C	CA_3A-41C	CA_7B-28A	CA_41C-42A	CA_1A-3A-40A	CA_3A-5A-40A
—	CA_1C-3A	CA_3A-42C	CA_7C-8A	CA_48A-66A-66A	CA_1A-3A-41A	CA_3A-7A-8A
—	CA_1C-41A	CA_3C-5A	CA_7C-20A	CA_48A-66B	CA_1A-3A-42A	CA_3A-7A-20A
—	CA_2A-2A-5A	CA_3C-7A	CA_7C-28A	CA_48A-66C	CA_1A-5A-7A	CA_3A-7A-28A
—	CA_2A-2A-12A	CA_3C-8A	CA_8A-39C	CA_48C-66A	CA_1A-5A-38A	CA_3A-7A-40A
—	CA_2A-2A-13A	CA_3C-20A	CA_8A-40C	CA_66A-66A-71A	CA_1A-5A-40A	CA_3A-7A-42A
—	CA_2A-2A-14A	CA_3C-28A	CA_8A-41C	CA_66A-66B	CA_1A-7A-8A	CA_3A-8A-38A
—	CA_2A-2A-29A	CA_3C-32A	CA_8A-42C	CA_66A-66C	CA_1A-7A-20A	CA_3A-8A-40A
—	CA_2A-2A-71A	CA_3C-40A	CA_12A-66A-66A	CA_66C-71A	CA_1A-7A-28A	CA_3A-19A-42A
—	CA_2A-5B	CA_3C-41A	CA_12A-66B	—	CA_1A-7A-32A	CA_3A-20A-38A
—	CA_2A-7A-7A	CA_4A-4A-5A	CA_12A-66C	—	CA_1A-7A-40A	CA_3A-20A-42A
—	CA_2A-7C	CA_4A-4A-7A	CA_13A-48C	—	CA_1A-7A-42A	CA_3A-28A-38A
—	CA_2A-12A-12A	CA_4A-4A-12A	CA_13A-66A-66A	—	CA_1A-8A-40A	CA_3A-28A-40A
—	CA_2A-12B	CA_4A-4A-13A	CA_13A-66B	—	CA_1A-19A-42A	CA_3A-28A-41A
—	CA_2A-48C	CA_4A-4A-71A	CA_13A-66C	—	CA_1A-20A-32A	CA_3A-28A-42A
—	CA_2A-66B	CA_4A-5B	CA_14A-66A-66A	—	CA_1A-20A-42A	CA_3A-41A-42A
—	CA_2A-66C	CA_4A-7A-7A	CA_19A-42C	—	CA_1A-26A-41A	CA_4A-7A-12A
—	CA_2C-5A	CA_4A-7C	CA_20A-38C	—	CA_1A-28A-42A	CA_5A-48A-66A
—	CA_2C-12A	CA_4A-12A-12A	CA_20A-40C	—	CA_1A-41A-42A	CA_7A-8A-40A
—	CA_2C-29A	CA_4A-12B	CA_25A-25A-26A	—	CA_2A-4A-5A	CA_7A-20A-32A
—	CA_2C-66A	CA_4A-48C	CA_26A-41A-41A	—	CA_2A-4A-12A	CA_7A-20A-42A
—	CA_3A-3A-5A	CA_5A-5A-66A	CA_26A-41C	—	CA_2A-4A-13A	CA_13A-48A-66A
—	CA_3A-3A-7A	CA_5A-7A-7A	CA_28A-40C	—	CA_2A-4A-71A	CA_20A-38A-40A
—	CA_3A-3A-8A	CA_5A-7C	CA_28A-41C	—	CA_2A-5A-48A	CA_28A-41A-42A
—	CA_3A-3A-20A	CA_5A-40A-40A	CA_28A-42C	—	CA_2A-5A-66A	—

Table B-3: EM759X Carrier Aggregation Uplink Combinations

CA_1C
CA_3C
CA_5B
CA_7C
CA_39C
CA_41C
CA_42C
CA_43C
CA_48C

C: Design Checklist

This chapter provides a summary of the design considerations mentioned throughout this guide. This includes items relating to the power interface, RF integration, thermal considerations, cabling issues, and so on.

Note: This is NOT an exhaustive list of design considerations. It is expected that you will employ good design practices and engineering principles in your integration.

Table C-1: Hardware Integration Design Considerations

Suggestion	Section where discussed
Component Placement	
If an ESD suppressor is not used on the host device, allow space on the SIM connector for series resistors in layout. (Up to 100 Ω may be used depending on ESD testing requirements).	SIM Implementation on page 31
Minimize RF cable losses as these affect performance values listed in product specification documents.	RF Connections on page 37
Antennas	
Match the module/antenna coax connections to 50 Ω — mismatched antenna impedance and cable loss negatively affect RF performance.	RF Connections on page 37
If installing UMTS and CDMA modules in the same device, consider using separate antennas for maximum performance.	Antennas and Cabling on page 37
Power	
Make sure the power supply can handle the maximum current specified for the module type.	Power Consumption on page 47
Limit the total impedance of VCC and GND connections to the SIM at the connector to less than 1 Ω (including any trace impedance and lumped element components — inductors, filters, etc.). All other lines must have a trace impedance less than 2 Ω .	SIM Implementation on page 31
Decouple the VCC line close to the SIM socket. The longer the trace length (impedance) from socket to module, the greater the capacitance requirement to meet compliance tests.	
PCB Signal Routing	
USB 2.0/3.0 — Route the USB interface signals over 90 $\Omega \pm 10\%$ differential lines on the PCB.	
USB 2.0 data lines must have closely matched trace lengths (within 2 mm (15 ps)). Trace lengths must be < 105 mm.	
USB 3.0 Tx/Rx differential pair length matching is < 0.7 mm (5 ps), and the recommended differential pair maximum length is < 100 mm.	
Route USB signals using a minimum number of vias and corners to reduce reflections and impedance changes.	
USB traces should be routed away from sensitive circuits and signals. Maintain good isolation, and spacing to all adjacent signals should be at least 2 \times the trace width.	

Table C-1: Hardware Integration Design Considerations (Continued)

Suggestion	Section where discussed
EMI / ESD	
Investigate sources of localized interference early in the design cycle.	Methods to Mitigate Decreased Rx Performance on page 39
Provide ESD protection for the SIM connector at the exposed contact point (in particular, the CLK, VCC, IO, DETECT and RESET# lines).	SIM Implementation on page 31
Keep very low capacitance traces on the UIM_DATA and UIM_CLK signals.	
To minimize noise leakage, establish a very good ground connection between the module and host.	Ground Connection on page 38
Route cables away from noise sources (for example, power supplies, LCD assemblies, etc.).	Methods to Mitigate Decreased Rx Performance on page 39
Shield high RF-emitting components of the host device (for example, main processor, parallel bus, etc.).	
Use discrete filtering on low frequency lines to filter out unwanted high-order harmonic energy.	
Use multi-layer PCBs to form shielding layers around high-speed clock traces.	
For HS_USB, the ESD protection is recommended on D+ and D-. The ESD diodes used in the design should have less than 3 pF of capacitance. For USB_SS_RX_M/P, include external ESD protection on Tx and Rx that is designed for GHz signals. The ESD diodes used in the design should have ~ 0.3 pF of capacitance.	
Thermal	
Test to worst case operating conditions — temperature, voltage, and operation mode (transmitter on 100% duty cycle, maximum power).	Thermal Considerations on page 61
Use appropriate techniques to reduce module temperatures (for example, airflow, heat sinks, heat-relief tape, module placement, etc.).	
Host / Modem Communication	
Make sure the host USB driver supports remote wakeup, resume, and suspend operations, and serial port emulation.	
When no valid data is being sent, do not send SOF tokens from the host (causes unnecessary power consumption).	
Windows Driver — Support Win10, Win11 for MBIM data connection Linux Driver — Support Linux kernel 4.4 and later for MBIM (cdc_mbim + libmbim) and RmNet (qmi_wwan + libqmi)	Libmbim: 1.24.8 Libqmi: 1.28.8

D: Testing

Note: All Sierra Wireless embedded modules are factory-tested to ensure they conform to published product specifications.

Developers of OEM devices integrating Sierra Wireless embedded modules should include a series of test phases in their manufacturing process to make sure their devices work properly with the embedded modules.

Suggested phases include:

- [Acceptance Testing](#)— Testing of modules when they are received from Sierra Wireless
- [Certification Testing](#)— Testing of completed devices to obtain required certifications before beginning mass production
- [Production Testing](#)— Testing of completed devices with the modules embedded
- [Quality Assurance Testing](#)— Post-production

D.1 AT Command Entry Timing Requirement

Some AT commands require time to process before additional commands are entered. For example, the modem will return "OK" when it receives **ATIDAFTMACT**. However, if **ATIDARCONFIG** is received too soon after this, the modem will return an error.

When building automated test scripts, ensure that sufficient delays are embedded where necessary to avoid these errors.

D.2 Acceptance Testing

Note: Acceptance testing is typically performed for each shipment received.

When you receive a shipment from Sierra Wireless, you should make sure it is suitable before beginning production.

From a random sampling of units, test that:

- Units are operational
- Units are loaded with the correct firmware version

D.2.1 Acceptance Test Requirements

To perform the suggested tests, you require a test system in which to temporarily install the module, and you must be able to observe the test device's LED indicator.

D.3 Certification Testing

Note: Typically, certification testing of your device with the integrated module is required one time only.

The Sierra Wireless embedded module has been certified as described in [Regulatory Compliance and Industry Certifications](#) on page 63.

When you produce a host device with a Sierra Wireless embedded module, you must obtain certifications for the final product from appropriate regulatory bodies in the jurisdictions where it will be distributed.

The following are *some* of the regulatory bodies from which you may require certification — it is your responsibility to make sure that you obtain all necessary certifications for your product from these or other groups:

- FCC (Federal Communications Commission — www.fcc.gov)
- Innovation, Science and Economic Development Canada (www.ic.gc.ca)
- GCF (Global Certification Forum — www.globalcertificationforum.org) outside of North America
- PTCRB (PCS Type Certification Review Board — www.ptcrb.com) in North America

D.4 Production Testing

Note: Production testing typically continues for the life of the product.

Production testing ensures that, for each assembled device, the module is installed correctly (I/O signals are passed between the host and module), and the antenna is connected and performing to specifications (RF tests).

Typical items to test include:

- Host connectivity
- Baseband (host/module connectors)
- RF assembly (Tx and/or Rx, as appropriate)
- Network availability
- Host/device configuration issues

*Note: The number and types of tests to perform are **your** decision — the tests listed in this section are guidelines only. Make sure that the tests you perform exercise functionality to the degree that **your** situation requires.*

Use an appropriate test station for your testing environment (see [Acceptance Test Requirements](#) on page 75 for suggestions) and use AT commands to control the integrated module.

Note: Your test location must be protected from ESD to avoid interference with the module and antenna(s), assuming that your test computer is in a disassembled state.

Also, consider using an RF shielding box — local government regulations may prohibit unauthorized transmissions.

D.5 Functional Production Test

This section presents a suggested procedure for performing a basic manual functional test on a laboratory bench using an EM759X Embedded Module and a hardware development kit. When you have become familiar with the testing method, use it to develop your own automated production testing procedures.

D.5.1 Suggested Production Tests

Consider the following tests when you design your production test procedures for devices with the Sierra Wireless module installed.

- Visual check of the module's connectors and RF assemblies
- Module is operational
- USB connection is functional
- Power on/off
- Firmware revision check
- Rx tests on main and auxiliary paths
- Tx test

D.5.2 Production Test Procedure

The following is a suggested test plan — you must decide which tests are appropriate for your product. You may wish to add additional tests that more fully exercise the capabilities of your product.

Using an appropriate Dev Kit-based test station, and referring to the appropriate AT command references:

1. Visually inspect the module's connectors and RF assemblies for obvious defects before installing it in the test station.
2. Ensure that the module is turned off before beginning your tests — Drive Full_Card_Power_Off# low or leave floating.
3. Test Full_Card_Power_Off# — Turn on the module by driving Full_Card_Power_Off# high.
4. Test USB functionality — Check for USB enumeration.

- (Windows systems) The Device Manager shows the device under **Network adapters**. For example:

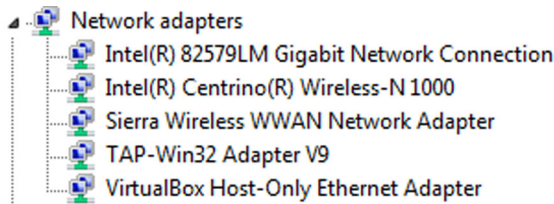

5. Make sure your modem is connected and running, and then establish contact with the module:
 - Windows systems: Use a terminal emulation / communications program such as Microsoft HyperTerminal® to connect to the Sierra Wireless modem (see listings in [Step 4](#)):
 - a. Start HyperTerminal.
 - b. Select **File > Connection Description**. The Connection Description dialog box appears.
 - i. Type Sierra in the Name box and click **OK**. The Connect To dialog box appears.
 - ii. Click **OK** without changing any of the displayed information. The Connect dialog box appears.
 - iii. Click **Cancel**.

*Note: If necessary, use **ATE1** to enable echo.*

- iv. Type ATZ in the HyperTerminal window. If the connection is established, the message OK appears.

6. Display the firmware version:
 - **AT+GMR**
7. Unlock the extended AT command set. (Note: Use AT!ENTERCND? to check command syntax, which is SKU-dependent.):
 - **AT!ENTERCND="<password>"**
8. Put the module in diagnostic/factory test mode:
 - **AT!DAFTMACT**
9. Communicate with the SIM using **+CPIN** or **+CIMI**.
When performing RF tests, use a test platform as described in [Suggested Testing Equipment](#) on page 87.
10. Test RF transmission, if desired:
 - (UMTS) See [UMTS \(WCDMA\) RF Transmission Path Test](#) on page 78.
 - (LTE) See [LTE RF Transmission Path Test](#) on page 80
11. Test RF reception, if desired:
 - (UMTS) See [UMTS \(WCDMA\) RF Receive Path Test](#) on page 82.
 - (LTE) See [LTE RF Receive Path Test](#) on page 83.
12. Test standalone GNSS functionality — See [GNSS RF Receive Path Test](#) on page 86.
13. Drive Full_Card_Power_Off# low (or leave floating) and confirm that the module powers down:
 - Windows systems — The Sierra Wireless items under the Ports (COM & LPT) entry in Device Manager disappear as the module powers off.

D.5.3 UMTS (WCDMA) RF Transmission Path Test

Note: This procedure segment is performed in [Step 10](#) of the [Production Test Procedure](#) on page 77.

The suggested test procedure that follows uses the parameters in [Table D-1](#).

Table D-1: Test Settings — UMTS Transmission Path

	Band	Frequency (MHz)	Band ID	Channel ^a
2100 MHz	Band 1	1950.0	9	9750
1900 MHz	Band 2	1880.0	15 ^b	9400
1700 MHz	Band 4	1732.6	28	1413
850 MHz	Band 5	836.6	22	4183
800 MHz	Band 6	835.0	22	4175
900 MHz	Band 8	897.6	29	2788
1700 MHz	Band 9	1767.4	31	8837
800 MHz	Band 19	837.6	75	338

- a. Channel value used by the !DARCONFIG command (!DARCONFIG uses uplink (Tx) channel at the center of the corresponding band (rounded down), for both Tx and Rx testing).
- b. Either 15 (WCDMA1900A) or 16 (WCDMA1900B) may be used for testing.

To test the DUT's transmitter path:

1. Set up the power meter:

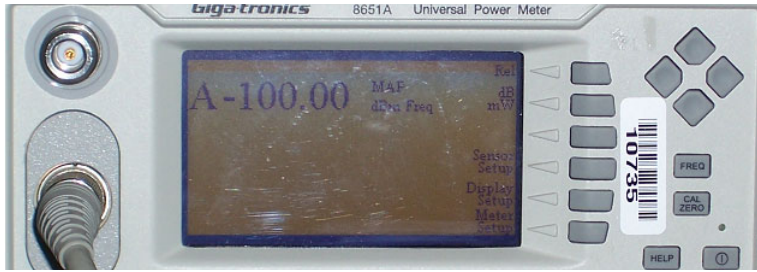

Note: This procedure describes steps using the "Power Meter: Gigatronics 8651A" (with Option 12 and Power Sensor 80701A).

- a. Make sure the meter has been given sufficient time to warm up, if necessary, to enable it to take accurate measurements.
 - b. Zero-calibrate the meter.
 - c. Enable MAP mode.
2. Prepare the DUT using the following AT commands:
 - a. **AT!ENTERCND="<password>"** (Unlock extended AT command set.)
 - b. **AT!DAFTMACT** (Enter test mode.)
 - c. **AT!DARCONFIG=0,1,<bandValue>,<channel>**
(e.g. AT!DARCONFIG=0,1,2,9400)
(Set frequency band and channel.
See [Table D-1](#) for values.)
 - d. **AT!DAWTXCONTROL=1,<power_dBm>**
(e.g. AT!DAWTXCONTROL=1,10)
(Enable Tx power output.
<power_dBm> = -57.0 to 23.0)
 - e. Take the measurement.
 - f. Repeat steps c–e with different Tx power levels if needed.
 - g. **AT!DAWTXCONTROL=0** (Disable Tx power output.)
 - h. **AT!DARCONFIGDROP=1** (Drop the current UMTS configuration.)
 3. Test limits— Run ten or more good DUTs through this test procedure to obtain a nominal output power value.
 - Apply a tolerance of ± 5 to 6 dB to each measurement (assuming a good setup design).
 - Monitor these limits during mass-production ramp-up to determine if further adjustments are needed.

Note: The module has a nominal output power of +23 dBm ± 1 dB in WCDMA mode. However, the value measured by the power meter is significantly influenced (beyond the stated ± 1 dB output power tolerance) by the test setup (host RF cabling loss, antenna efficiency and pattern, test antenna efficiency and pattern, and choice of shield box).

Note: When doing the same test over the air in an RF chamber, values are likely to be significantly lower.

D.5.4 LTE RF Transmission Path Test

Note: This procedure segment is performed in [Step 10](#) of the [Production Test Procedure](#) on page 77.

The suggested test procedure that follows uses the parameters in [Table D-2](#).

Table D-2: Test Settings — LTE Transmission Path

	Band #	Frequency (MHz)	Band ID	Channel ^a
2100 MHz	B1	1950.0	34	18300
1900 MHz	B2	1880.0	43	18900
1800 MHz	B3	1747.5	44	19575
1700 MHz	B4	1732.5	42	20175
850 MHz	B5	836.5	45	20525
2600 MHz	B7	2535.0	35	21100
900 MHz	B8	897.5	47	21625
700 MHz	B12	707.5	50	23095
700 MHz	B13	782.0	36	23230
700 MHz	B14	793.0	51	23330
850 MHz	B18	822.5	54	23925
850 MHz	B19	837.5	55	24075
800 MHz	B20	847.0	56	24300
1900 MHz	B25	1882.5	61	26365
850 MHz	B26	831.5	62	26865
700 MHz	B28	725.5	64	27435
2600 MHz	B38	2595.0	38	38000
1900 MHz	B39	1900.0	74	38450
2300 MHz	B40	2350.0	39	39150
2500 MHz	B41	2593.0	76	40620
3500 MHz	B42	3500.0	77	42590
3700 MHz	B43	3700.0	88	44590
3600 MHz	B48	3625.0	96	55990
1700 MHz	B66	1745.0	83	132322
600 MHz	B71	680.5	97	133297
900 MHz	B106	898.5	187	134317

a. Channel value used by the !DARCONFIG command (!DARCONFIG uses uplink (Tx) channel at the center of the corresponding band (rounded down), for both Tx and Rx testing).

To test the DUT's transmitter path:

1. Set up the power meter:

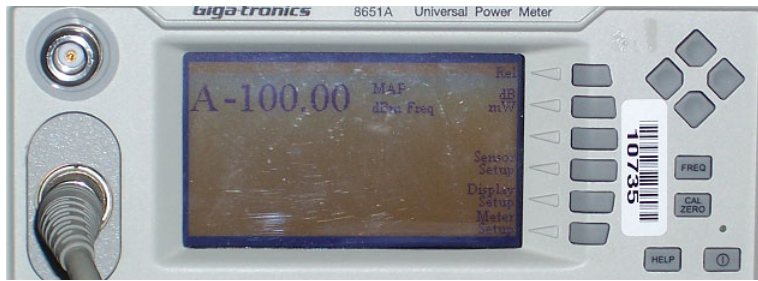

Note: This procedure describes steps using the "Power Meter: Gigatronics 8651A" (with Option 12 and Power Sensor 80701A).

- a. Make sure the meter has been given sufficient time to warm up, if necessary, to enable it to take accurate measurements.
 - b. Zero-calibrate the meter.
 - c. Enable MAP mode.
2. Prepare the DUT using the following AT commands:
 - a. **AT+ENTERCND=<password>** (Unlock extended AT command set.)
 - b. **AT+IDAFTMACT** (Enter test mode.)
 - c. **AT+DARCONFIG=0,3,<bandValue>,<channel>,<lte_bw>**
(e.g. AT+DARCONFIG=0,3,1,18300,3)
(Set frequency band and channel. See [Table D-1](#) for values. <lte_bw>: 0 (1.4 MHz), 1 (3 MHz), 2 (5 MHz), 3 (10 MHz), 4 (15 MHz), 5(20 MHz))
 - d. **AT+DALTXCONTROL=0,1,<tx_pwr>,<waveform>,<mod>,<ns_val>,<num_RB>,<start_RB>**
(e.g. AT+DALTXCONTROL=0,1,10,1,0,1,12,19)
(Set LTE Tx power level, waveform, modulation and NS value. Programs PA range, LUT index, and digital gain to reach Tx power level with power limiting enabled.)
 - e. Take the measurement.
 - f. Repeat steps c–e with different Tx power levels if desired.
 - g. **AT+DALTXCONTROL=0,0** (Disable Tx power control.)
 - h. **AT+DARCONFIGDROP=3** (Drop the current LTE configuration.)
 3. Test limits— Run ten or more good DUTs through this test procedure to obtain a nominal output power value.
 - Apply a tolerance of ± 5 to 6 dB to each measurement (assuming a good setup design).
 - Monitor these limits during mass-production ramp-up to determine if further adjustments are needed.

Note: The module has a nominal output power of +23 dBm ± 1 dB in LTE mode. However, the value measured by the power meter is significantly influenced (beyond the stated ± 1 dB output power tolerance) by the test setup (host RF cabling loss, antenna efficiency and pattern, test antenna efficiency and pattern, and choice of shield box).

Note: When doing the same test over the air in an RF chamber, values are likely to be significantly lower.

D.5.5 UMTS (WCDMA) RF Receive Path Test

Note: This procedure segment is performed in Step 11 of Production Test Procedure on page 77.

The suggested test procedure that follows uses the parameters in Table D-3.

Table D-3: Test Settings — UMTS Receive Path

	Band #	Frequency ^a (MHz)	Band ID	Channel ^b
2100 MHz	Band 1	2141.2	9	9750
1900 MHz	Band 2	1961.2	15 ^c	9400
1700 MHz	Band 4	2133.7	28	1413
850 MHz	Band 5	882.7	22	4183
800 MHz	Band 6	881.2	22	4175
900 MHz	Band 8	943.7	29	2788
1700 MHz	Band 9	1863.6	31	8837
800 MHz	Band 19	883.7	75	338

- a. Receive frequencies shown are 1.2 MHz offset from center
- b. Channel value used by the !DARCONFIG command (!DARCONFIG uses uplink (Tx) channel at the center of the corresponding band (rounded down), for both Tx and Rx testing).
- c. Either 15 (WCDMA1900A) or 16 (WCDMA1900B) may be used for testing.

To test the DUT's receive path:

1. Set up the signal generator:

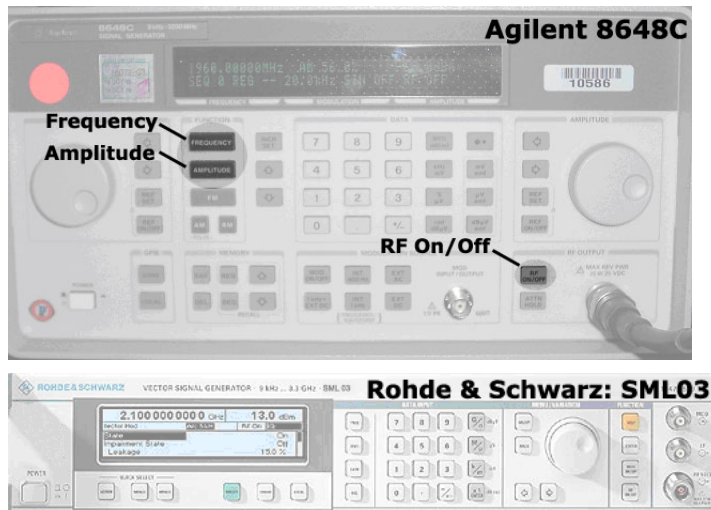

Note: This procedure describes steps using the Agilent 8648C signal generator—the Rohde & Schwarz SML03 is shown for reference only.

- a. Set the amplitude to:
 - -80 dBm
 - b. Set the frequency for the band being tested. See [Table D-3](#) on page 82 for frequency values.
2. Set up the DUT:

Warning: *The maximum RF power level allowable on any RF port is +10dBm—damage may occur if this level is exceeded.*

- a. **AT+ENTERCND=<password>** (Unlock extended AT command set.)
 - b. **AT+IDAFTMACT** (Put modem into factory test mode.)
 - c. **AT+DARCONFIG=0,1,<bandValue>,<channel>**
(e.g. AT+DARCONFIG=0,1,2,9400)
(Set frequency band and channel.
See [Table D-3](#) for values.)
 - d. **AT+DAGFTMRXAGC=0,1,0,0**
(Set LNA to maximum gain on primary Rx, and
get the RSSI.)
 - e. **AT+DAGFTMRXAGC=0,1,0,1** (Set LNA to maximum gain on Diversity Rx, and
get the RSSI.)
 - f. **AT+DARCONFIGDROP=1** (Drop the current UMTS configuration.)
3. Test limits — Run ten or more good DUTs through this test procedure to obtain a nominal received power value.
- Apply a tolerance of ± 5 to 6 dB to each measurement (assuming a good setup design).
 - Make sure the measurement is made at a high enough level that it is not influenced by DUT-generated and ambient noise.
 - The Signal Generator power level can be adjusted and new limits found if the radiated test needs greater signal strength.
 - Monitor these limits during mass-production ramp-up to determine if further adjustments are needed.

Note: The value measured from the DUT is significantly influenced by the test setup and DUT design (host RF cabling loss, antenna efficiency and pattern, test antenna efficiency and pattern, and choice of shield box).

D.5.6 LTE RF Receive Path Test

Note: This procedure segment is performed in [Step 11](#) of the [Production Test Procedure](#) on page 77.

The suggested test procedure that follows uses the parameters in [Table D-4](#).

Table D-4: Test Settings — LTE Receive Path

	Band #	Frequency ^a (MHz)	Band ID	Channel ^b
2100 MHz	B1	2142.0	34	18300
1900 MHz	B2	1962.0	43	18900
1800 MHz	B3	1844.5	44	19575
1700 MHz	B4	2134.5	42	20175

Table D-4: Test Settings — LTE Receive Path (Continued)

	Band #	Frequency ^a (MHz)	Band ID	Channel ^b
850 MHz	B5	883.5	45	20525
2600 MHz	B7	2657.0	35	21100
900 MHz	B8	944.5	47	21625
700 MHz	B12	739.5	50	23095
700 MHz	B13	753.0	36	23230
850 MHz	B14	765	51	23330
850 MHz	B18	869.5	54	23925
850 MHz	B19	884.5	55	24075
800 MHz	B20	808.0	56	24300
1900 MHz	B25	1962.5	61	8365
850 MHz	B26	878.5	62	26865
700 MHz	B28	780.5	64	27435
700 MHz	B29	See footnote ^c		
1500 MHz	B32	See footnote ^c .		
2600 MHz	B38	2595.0	38	38000
1900 MHz	B39	1900.0	74	38450
2300 MHz	B40	2350.0	39	39150
2500 MHz	B41	2595.0	76	40620
3500 MHz	B42	3502.0	77	42590
3700 MHz	B43	3702.0	88	44590
3600 MHz	B48	3627.0	96	55990
1700 MHz	B66	2157.0	83	132322
600 MHz	B71	636.5	97	133297
900 MHz	B106	939.5	187	134317

- a. Receive frequencies shown are 2 MHz offset from center
- b. Channel value used by the !DARCONFIG command (!DARCONFIG uses uplink (Tx) channel at the center of the corresponding band (rounded down), for both Tx and Rx testing).
- c. Test procedure does not apply to this band. Downlink-only band requires CA mode testing in signaling mode (outside scope of this document; testing methodology to be determined by user).

To test the DUT's receive path (or diversity path, while connected to the diversity antenna):

1. Set up the signal generator:

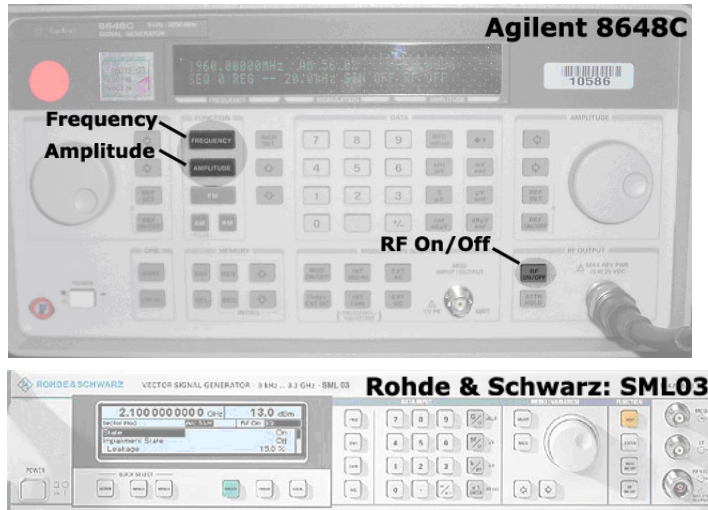

Note: This procedure describes steps using the Agilent 8648C signal generator—the Rohde & Schwarz SML03 is shown for reference only.

- a. Set the amplitude to -70 dBm
 - b. Set the frequency for the band being tested. See [Table D-4](#) for frequency values.
2. Set up the DUT:

Warning: *The maximum RF power level allowable on any RF port is +10dBm—damage may occur if this level is exceeded.*

- a. **ATIENTERCND=<password>** (Unlock extended AT command set.)
 - b. **ATIDAFTMACT** (Put modem into factory test mode.)
 - c. **ATIDARCONFIG=0,3,<bandValue>,<channel>,<lte_bw>**
(e.g. ATIDARCONFIG=0,3,1,18300,3)
(Set frequency band and channel. See [Table D-4](#) for values. <lte_bw>: 0 (1.4 MHz), 1 (3 MHz), 2 (5 MHz), 3 (10 MHz), 4 (15 MHz), 5(20 MHz))
 - d. **ATIDAGFTMRXAGC=0,3,0,0** (Set LNA to maximum gain on primary Rx, and get the RSSI.)
 - e. **ATIDAGFTMRXAGC=0,3,0,1** (Set the LNA to maximum gain on Diversity Rx, and get the RSSI.)
 - f. **ATIDARCONFIGDROP=3** (Drop the current LTE configuration.)
3. Test limits—Run ten or more good DUTs through this test procedure to obtain a nominal received power value.
 - Apply a tolerance of ± 5 to 6 dB to each measurement (assuming a good setup design).
 - Make sure the measurement is made at a high enough level that it is not influenced by DUT-generated and ambient noise.
 - The Signal Generator power level can be adjusted and new limits found if the radiated test needs greater signal strength.
 - Monitor these limits during mass-production ramp-up to determine if further adjustments are needed.

Note: The value measured from the DUT is significantly influenced by the test setup and DUT design (host RF cabling loss, antenna efficiency and pattern, test antenna efficiency and pattern, and choice of shield box).

D.5.7 GNSS RF Receive Path Test

The GNSS receive path uses either the dedicated GNSS connector or the shared Diversity/MIMO/GNSS connector.

To test the GNSS receive path:

1. Inject a carrier signal at -110 dBm, frequency 1575.52 MHz into the GNSS Rx path at the connector. (Note that this frequency is 100 kHz higher than the actual GPS L1 center frequency.)
2. Test the signal carrier-to-noise level at the GNSS receiver:
 - a. **AT+ENTERCND=<password>** (Unlock extended AT command set.)
 - b. **AT+IDAFTMACT** (Put modem into factory test mode.)
 - c. **AT+IDACGPSTESTMODE=1** (Start CGPS diagnostic task.)
 - d. **AT+IDACGPSSTANDALONE=0** (Enter standalone RF mode.)
 - e. **AT+IDACGPSMASKON** (Enable log mask.)
 - f. **AT+IDACGPSCTON** (Return signal-to-noise and frequency measurements.)
 - g. Repeat **AT+IDACGPSCTON** five to ten times to ensure the measurements are repeatable and stable.
3. Leave the RF connection to the embedded module intact, and turn off the signal generator.
4. Take several more **IDACGPSCTON** readings. This will demonstrate a 'bad' signal in order to set limits for testing, if needed. This frequency offset should fall outside of the guidelines in the note below, which indicates that the CtoN result is invalid.
5. (Optional) Turn the signal generator on again, and reduce the level to -120 dBm. Take more **IDACGPSCTON** readings and use these as a reference for what a marginal / poor signal would be.

*Note: The response to **AT+IDACGPSCTON** for a good connection should show CtoN within 58 ± 5 dB and Freq (frequency offset) within $100000 \text{ Hz} \pm 5000 \text{ Hz}$.*

D.6 Quality Assurance Testing

Note: QA is an ongoing process based on random samples from a finished batch of devices.

The quality assurance tests that you perform on your finished products should be designed to verify the performance and quality of your devices.

The following are *some* testing suggestions that can confirm that the antenna is interfaced properly, and that the RF module is calibrated and performs to specifications:

- Module registration on cellular networks
- Power consumption
- Originate and terminate data and voice (if applicable) calls
- Cell hand-off
- Transmitter and receiver tests
- FER (Frame Error Rate) as an indicator of receiver sensitivity / performance

- Channel and average power measurements to verify that the device is transmitting within product specifications
- RF sensitivity tests
- RF sensitivity testing—BER/BLER for different bands and modes
- Transmitter and receiver tests (based on relevant sections of the 3GPP TS 51.010 and 3GPP TS 34.121 documents)

D.7 Suggested Testing Equipment

To perform production and post-production tests, you will require appropriate testing equipment. A test computer can be used to coordinate testing between the integrated module (on the development kit or host) and the measurement equipment, usually with GPIB connections. The suggested setup includes a power meter to test RF output power and a signal generator to evaluate the receiver.

D.8 Testing Assistance Provided by Sierra Wireless

Extended AT commands have been implemented to assist with performing FTA GCF tests and portions of CE Mark tests requiring radio module access. These are documented in the [1] *Sierra Wireless EM759X AT Command Reference (Doc# 41114426)*.

Sierra Wireless offers optional professional services based assistance to [OEMs](#) with regulatory approvals.

D.9 IOT/Operator Testing

Interoperability and Operator/Carrier testing of the finished system is the responsibility of the [OEM](#). The test process will be determined with the chosen network operator(s) and will be dependent upon your business relationship with them, as well as the product's application and sales channel strategy.

Sierra Wireless offers assistance to OEMs with the testing process, if required.

D.10 Extended AT Commands for Testing

Sierra Wireless provides the [1] *Sierra Wireless EM759X AT Command Reference (Doc# 41114426)*, which describes proprietary AT commands that may help in hardware integration design and testing (these commands are NOT intended for use by end users).

Some commands from this document that may be useful for hardware integration are listed in [Table D-5](#) on page 87.

Table D-5: Extended AT Commands

Command	Description
Password commands	
!ENTERCND	Enable access to password-protected commands
!SETCND	Set AT command password
Modem reset and status commands	
!GSTATUS	Return the operation status of the modem (mode, band, channel, etc.)

Table D-5: Extended AT Commands

Command	Description
!RESET	Reset the modem
Diagnostic commands	
!BAND	Select a set of frequency bands or reports current selection
Test commands	
!DAFTMACT	Put the modem into FTM (Factory Test Mode)
!DAFTMDEACT	Put the modem into online mode
!DAGFTMRXAGC	Get FTM Rx AGC (Primary or Diversity)
!DALGRXAGC	Return Rx AGC value (LTE)
!DALGTXAGC	Return Tx AGC value and transmitter parameters (LTE)
!DALTXCONTROL	Configure LTE Tx Parameters
!DAOFFLINE	Place modem offline
!DARCONFIG	Set Band and Channel
!DARCONFIGDROP	Drop Radio Configurations
!DAWTXCONTROL	Configure WCDMA Tx Power

E: Thermal Testing

E.1 Worst Case Testing

Sierra Wireless recommends that customers identify realistic worst-case conditions for their platforms and perform appropriate thermal testing.

For example:

- If the device has very good throughput, it is likely near a tower so will not have to transmit at maximum Tx output power.
- If the device is transmitting at maximum Tx power, it is likely not near a tower and will not reach maximum throughput rates.
- Networks usually are sharing capacity among many users, so no single user is likely to reach maximum throughput rates for any significant length of time.
- If the device is transmitting at maximum throughput, it will likely do so for a limited time to limit the amount of data usage consumed from their data plan.

Suggested realistic worst-case test conditions

Sierra Wireless suggests using a worst-case test such as shown in [Table E-1](#).

Table E-1: Thermal Testing — Suggested Worst Case Conditions

Condition	EM7590	EM7595
Data throughput rate	383 Mbps / 147 Mbps	585 Mbps / 147 Mbps
Tx output power	23 dBm	23 dBm
Carrier aggregation	2CA	3CA

E.2 Thermal Testing Process

To perform thermal testing of the module:

1. Mount the module in its designed location on the platform.
2. Provide the same amount of airflow as will be experienced in your platform.

Note: It is highly recommended to have a thermocouple measuring the air temperature around the module inside the platform, which will be close to the module's board temperature.

3. Set up a call with the use case for the platform (throughput rate, output power, duty cycle) on the worst-case band.
4. Observe the ramp in board temperature due to the call, and confirm whether the overall system performance still meets customer requirements.
5. Use **AT!TMSTATUS?** to check the module's thermal mitigation status (refer to [1] *Sierra Wireless EM759X AT Command Reference (Doc# 41114426)* for details).

6. Increase the platform's ambient temperature to determine the margin that exists over the desired temperature specifications as subsequent mitigation methods activate (e.g. UL data rate throttled, DL throughput throttled (second CA dropped), UL power reduced, Emergency Service).

F: Packaging

Sierra Wireless Embedded Modules are shipped in sealed boxes. The standard packaging (see [Figure 0-1](#)), contains a single tray with a capacity of 100 modules. (Note that some SKUs may have custom packaging—contact Sierra Wireless for SKU-specific details.)

In the standard packaging, Embedded Modules are inserted, system connector first, into the bottom portion (T1) of a two-part tray, all facing the same direction. This allows the top edge of each Embedded Module to contact the top of the triangular features in the top portion (T2) of the tray (Detail A).

The top and bottom portions of the tray snap together at the four connection points.

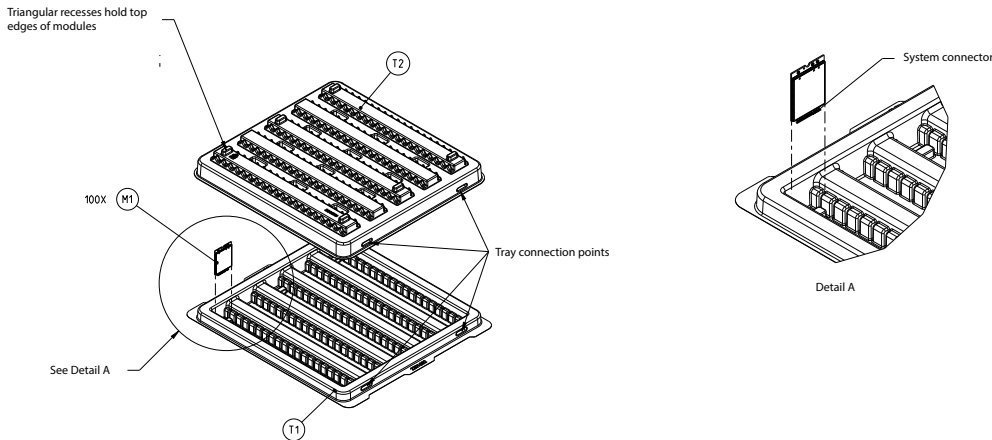

Figure 0-1: Device Placement in Module Tray

The tray cover is secured to the tray base with ESD-safe tape (EP1) at the locations indicated. The tray is placed in a manufacturing box (B1), sealed with a security tape (P1), a manufacturing label (L3) is placed on the bottom-right corner, above the security tape, and if required a label (L4) is applied beside the manufacturing label. (See [Figure 0-2](#).)

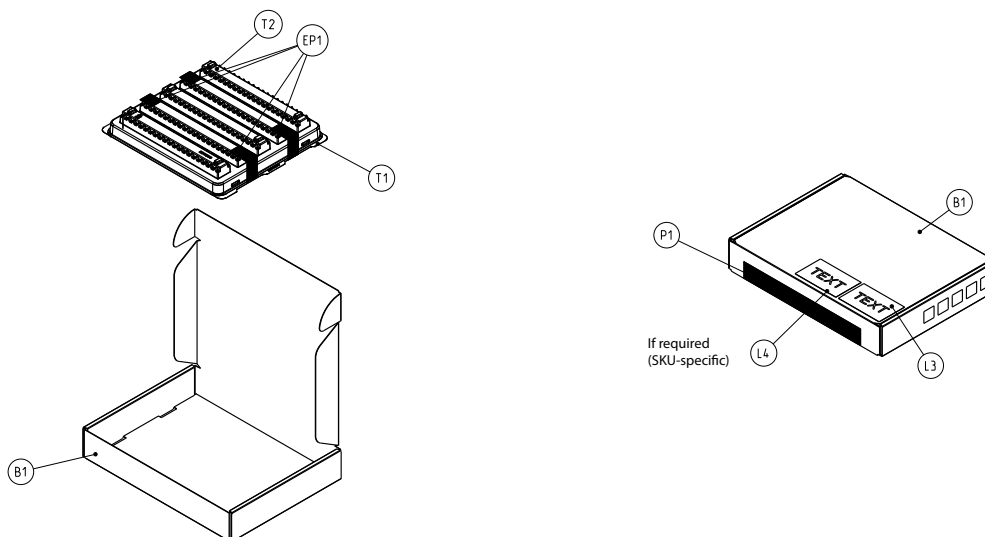

Figure 0-2: Shipping Package

G: References

G.1 Sierra Wireless Documents

Sierra Wireless documents are available from source.sierrawireless.com, or on request (subject to license agreements or NDAs) from your Sierra Wireless representative.

Sierra Wireless Documents on the Source

The following documents are available from source.sierrawireless.com:

- [1] Sierra Wireless EM759X AT Command Reference (Doc# 41114426)
- [2] AirPrime EM Series USB3.0 (M.2) Development Kit User Guide (Doc# 5303013)
- [3] EM759X Thermal Mitigation Guide (Doc# 2174324)

G.2 Industry/Other Documents

The following referenced document are not provided by Sierra Wireless:

- [4] AT Command Set for User Equipment (UE) (Release 6) (Doc# 3GPP TS 27.007)
- [5] PCI Express NGFF (M.2) Specification Revision 1.0
- [6] Universal Serial Bus Specification, Rev 2.0
- [7] Universal Serial Bus Specification, Rev 3.0

H: Abbreviations

Table H-1: Abbreviations and Definitions

Abbreviation or Term	Definition
3GPP	3rd Generation Partnership Project
8PSK	Octagonal Phase Shift Keying
AGC	Automatic Gain Control
A-GPS	Assisted GPS
API	Application Programming Interface
BeiDou	BeiDou Navigation Satellite System A Chinese system that uses a series of satellites in geostationary and middle earth orbits to provide navigational data.
BER	Bit Error Rate — A measure of receive sensitivity
BLER	Block Error Rate
Bluetooth	Wireless protocol for data exchange over short distances
CQI	Channel Quality Indication
COM	Communication port
CPE	Customer-Premises Equipment
CS	Circuit-switched
CSG	Closed Subscriber Group
CW	Continuous waveform
dB	Decibel = $10 \times \log_{10}(P1/P2)$ <i>P1 is calculated power; P2 is reference power</i> Decibel = $20 \times \log_{10}(V1/V2)$ <i>V1 is calculated voltage, V2 is reference voltage</i>
dBm	A logarithmic (base 10) measure of relative power (dB for decibels); relative to milliwatts (m). A dBm value will be 30 units (1000 times) larger (less negative) than a dBW value, because of the difference in scale (milliwatts vs. watts).
DC-HSPA+	Dual Carrier HSPA+
DCS	Digital Cellular System A cellular communication infrastructure that uses the 1.8 GHz radio spectrum.
DL	Downlink (network to mobile)
DRX	Discontinuous Reception
DSM	Distributed Shared Memory
DUT	Device Under Test

Table H-1: Abbreviations and Definitions (Continued)

Abbreviation or Term	Definition
EGNOS	European Geostationary Navigation Overlay Service (SBAS for GPS, GLONASS, Galileo)
eICIC	Enhanced Inter-Cell Interference Coordination
EIRP	Effective (or Equivalent) Isotropic Radiated Power
EMC	Electromagnetic Compatibility
EMI	Electromagnetic Interference
ENDC	E-UTRAN New Radio — Dual Connectivity
EP	End Point
ERP	Effective Radiated Power
ESD	Electrostatic Discharge
FCC	Federal Communications Commission The U.S. federal agency that is responsible for interstate and foreign communications. The FCC regulates commercial and private radio spectrum management, sets rates for communications services, determines standards for equipment, and controls broadcast licensing. Consult www.fcc.gov .
FDD	Frequency Division Duplexing
FDMA	Frequency Division Multiple Access
feICIC	Further Enhanced Inter-Cell Interference Coordination
FER	Frame Error Rate — A measure of receive sensitivity.
firmware	Software stored in ROM or EEPROM; essential programs that remain even when the system is turned off. Firmware is easier to change than hardware but more permanent than software stored on disk.
FOTA	Firmware Over The Air — Technology used to download firmware upgrades directly from the service provider, over the air.
FOV	Field Of View
FPC	Flexible Printed Cable
FSN	Factory Serial Number—A unique serial number assigned to the module during manufacturing.
Galileo	A European system that uses a series of satellites in middle earth orbit to provide navigational data.
GCF	Global Certification Forum
GLONASS	Global Navigation Satellite System — A Russian system that uses a series of 24 satellites in middle circular orbit to provide navigational data.
GMSK	Gaussian Minimum Shift Keying modulation
GNSS	Global Navigation Satellite Systems (GPS, GLONASS, BeiDou, and Galileo)
GPS	Global Positioning System An American system that uses a series of 24 satellites in middle circular orbit to provide navigational data.
HB	High Band

Table H-1: Abbreviations and Definitions (Continued)

Abbreviation or Term	Definition
Host	The device into which an embedded module is integrated
HSDPA	High Speed Downlink Packet Access
HSPA+	Enhanced HSPA, as defined in 3GPP Release 7 and beyond
HSUPA	High Speed Uplink Packet Access
Hz	Hertz = 1 cycle/second
IC	Industry Canada
IF	Intermediate Frequency
IMEI	International Mobile Equipment Identity
IMS	IP Multimedia Subsystem—Architectural framework for delivering IP multimedia services.
inrush current	Peak current drawn when a device is connected or powered on
inter-RAT	Radio Access Technology
IOT	Interoperability Testing
IS	Interim Standard. After receiving industry consensus, the TIA forwards the standard to ANSI for approval.
ISIM	IMS Subscriber Identity Module (Also referred to as a SIM card)
LAA	Licensed Assisted Access
LB	Low Band
LED	Light Emitting Diode. A semiconductor diode that emits visible or infrared light.
LHCP	Left-Hand Circular Polarized
LNA	Low Noise Amplifier
LPM	Low Power Mode
LPT	Line Print Terminal
LTE	Long Term Evolution—a high-performance air interface for cellular mobile communication systems.
MB	Mid Band
MCS	Modulation and Coding Scheme
MHz	Megahertz = 10e6 Hz
MIMO	Multiple Input Multiple Output—wireless antenna technology that uses multiple antennas at both transmitter and receiver side. This improves performance.
MPR	Maximum Power Reduction
MSAS	Multi-functional Satellite Augmentation System (SBAS for GPS)

Table H-1: Abbreviations and Definitions (Continued)

Abbreviation or Term	Definition
NAS/AS	Network Access Server
NC	No Connect
NIC	Network Interface Card
NLIC	Non-Linear Interference Cancellation
NMEA	National Marine Electronics Association
NSA	5G Non-standalone architecture
ODM	Original Design Manufacturer
OEM	Original Equipment Manufacturer—a company that manufactures a product and sells it to a reseller.
OFDMA	Orthogonal Frequency Division Multiple Access
OMA DM	Open Mobile Alliance Device Management — A device management protocol.
OS	Operating System
OTA	'Over the air' (or radiated through the antenna)
PA	Power Amplifier
packet	A short, fixed-length block of data, including a header, that is transmitted as a unit in a communications network.
PCB	Printed Circuit Board
PCC	Primary Component Carrier
PCS	Personal Communication System A cellular communication infrastructure that uses the 1.9 GHz radio spectrum.
PDN	Packet Data Network
PMI	Pre-coding Matrix Index
PRX	Primary Reception
PSS	Primary synchronization signal
PST	Product Support Tools
PTCRB	PCS Type Certification Review Board
QAM	Quadrature Amplitude Modulation. This form of modulation uses amplitude, frequency, and phase to transfer data on the carrier wave.
QCI	QoS Class Identifier
QMI	Qualcomm MSM/Modem Interface
QOS	Quality of Service
QPSK	Quadrature Phase-Shift Keying

Table H-1: Abbreviations and Definitions (Continued)

Abbreviation or Term	Definition
QPST	Qualcomm Product Support Tools
QZSS	Quasi-Zenith Satellite System — Japanese system for satellite-based augmentation of GPS.
RAT	Radio Access Technology
RC	Root Complex
RF	Radio Frequency
RI	Ring Indicator
roaming	A cellular subscriber is in an area where service is obtained from a cellular service provider that is not the subscriber's provider.
RSE	Radiated Spurious Emissions
RSSI	Received Signal Strength Indication
SA	5G Standalone architecture
SAR	Specific Absorption Rate
SBAS	Satellite-based Augmentation System
SCC	Secondary Component Carrier
SCS	Subcarrier Spacing
SDK	Software Development Kit
SED	Smart Error Detection
Sensitivity (Audio)	Measure of lowest power signal that the receiver can measure.
Sensitivity (RF)	Measure of lowest power signal at the receiver input that can provide a prescribed BER/BLER/SNR value at the receiver output.
SG	An LTE signaling interface for SMS ("SMS over SGs")
SIB	System Information Block
SIM	Subscriber Identity Module. Also referred to as USIM or UICC.
SIMO	Single Input Multiple Output—smart antenna technology that uses a single antenna at the transmitter side and multiple antennas at the receiver side. This improves performance and security.
SISO	Single Input Single Output—antenna technology that uses a single antenna at both the transmitter side and the receiver side.
SKU	Stock Keeping Unit—identifies an inventory item: a unique code, consisting of numbers or letters and numbers, assigned to a product by a retailer for purposes of identification and inventory control.
SMS	Short Message Service. A feature that allows users of a wireless device on a wireless network to receive or transmit short electronic alphanumeric messages (up to 160 characters, depending on the service provider).
S/N	Signal-to-noise (ratio)

Table H-1: Abbreviations and Definitions (Continued)

Abbreviation or Term	Definition
SNR	Signal-to-Noise Ratio
SOF	Start of Frame — A USB function.
SSS	Secondary synchronization signal.
SUPL	Secure User Plane Location
TDD	Time Division Duplexing
TD-SCDMA	Time Division Synchronous Code Division Multiple Access
TIA/EIA	Telecommunications Industry Association / Electronics Industry Association. A standards setting trade organization, whose members provide communications and information technology products, systems, distribution services and professional services in the United States and around the world. Consult www.tiaonline.org .
TIS	Total Isotropic Sensitivity
TRP	Total Radiated Power
TRX	Transceiver Transmits and receives signals
UDK	Universal Development Kit (for PCI Express Mini Cards)
UE	User Equipment
UHB	Ultra-High Band
UICC	Universal Integrated Circuit Card (Also referred to as a SIM card.)
UL	Uplink (mobile to network)
UMTS	Universal Mobile Telecommunications System
USB	Universal Serial Bus
USIM	Universal Subscriber Identity Module (UMTS)
VCC	Supply voltage
VDC	Volts DC
VSWR	Voltage Standing Wave Ratio
WAN	Wide Area Network
WCDMA	Wideband Code Division Multiple Access (also referred to as UMTS)
WLAN	Wireless Local Area Network
WWAS	Wide Area Augmentation System (SBAS for GPS)
ZIF	Zero Intermediate Frequency
ZUC	ZUC stream cypher