

Test Report

(EN 50155 & EN 50121-3-2)

Report No.: CEAAGC-WTW-P21070535

Test Model: XR80 5G

Series Model: XR80 LTE Cat-20 (refer to item 3.1 for more details)

Received Date: Sep. 24, 2021

Test Date: DEC. 29, 2021 ~ Mar. 02, 2022

Issued Date: Mar. 11, 2022

Applicant: Sierra Wireless, Inc.

Address: 13811 Wireless Way, Richmond, BC, Canada, V6V3A4

Issued By: Bureau Veritas Consumer Products Services (H.K.) Ltd., Taoyuan Branch
Lin Kou Laboratories

Lab Address: No. 47-2, 14th Ling, Chia Pau Vil., Lin Kou Dist., New Taipei City, Taiwan

Test Location: No. 19, Hwa Ya 2nd Rd., Wen Hwa Vil., Kwei Shan Dist., Taoyuan City
33383, TAIWAN



This report is for your exclusive use. Any copying or replication of this report to or for any other person or entity, or use of our name or trademark, is permitted only with our prior written permission. This report sets forth our findings solely with respect to the test samples identified herein. The results set forth in this report are not indicative or representative of the quality or characteristics of the lot from which a test sample was taken or any similar or identical product unless specifically and expressly noted. Our report includes all of the tests requested by you and the results thereof based upon the information that you provided to us. You have 60 days from date of issuance of this report to notify us of any material error or omission caused by our negligence, provided, however, that such notice shall be in writing and shall specifically address the issue you wish to raise. A failure to raise such issue within the prescribed time shall constitute your unqualified acceptance of the completeness of this report, the tests conducted and the correctness of the report contents. Unless specific mention, the uncertainty of measurement has been explicitly taken into account to declare the compliance or non-compliance to the specification.

Table of Contents

| | |
|------------------------------------------------------------------------------------|-----------|
| Release Control Record | 4 |
| 1 Certificate of Conformity | 5 |
| 2 Summary of Test Results | 6 |
| 2.1 Performance Criteria | 9 |
| 2.2 Measurement Uncertainty | 9 |
| 2.3 Modification Record..... | 9 |
| 3 General Information | 10 |
| 3.1 General Description of EUT | 10 |
| 3.2 Features of EUT | 10 |
| 3.3 Operating Modes of EUT and Determination of Worst Case Operating Mode | 11 |
| 3.4 Test Program Used and Operation Descriptions..... | 12 |
| 3.5 Primary Clock Frequencies of Internal Source..... | 12 |
| 4 Configuration and Connections with EUT..... | 13 |
| 4.1 Connection Diagram of EUT and Peripheral Devices | 13 |
| 4.2 Configuration of Peripheral Devices and Cable Connections | 16 |
| 5 Conducted Disturbance at Auxiliary a.c. Power Ports | 18 |
| 5.1 Limits | 18 |
| 5.2 Test Instruments | 18 |
| 5.3 Test Arrangement | 19 |
| 5.4 Test Results | 20 |
| 6 Radiated Disturbance up to 1 GHz | 22 |
| 6.1 Limits | 22 |
| 6.2 Test Instruments | 22 |
| 6.3 Test Arrangement | 23 |
| 6.4 Test Results | 24 |
| 7 Radiated Disturbance above 1 GHz | 26 |
| 7.1 Limits | 26 |
| 7.2 Test Instruments | 27 |
| 7.3 Test Arrangement | 28 |
| 7.4 Test Results | 29 |
| 8 Electrostatic Discharge Immunity Test (ESD)..... | 31 |
| 8.1 Test Specification | 31 |
| 8.2 Test Instruments | 31 |
| 8.3 Test Arrangement | 32 |
| 8.4 Test Results | 33 |
| 9 Radiated, Radio-frequency, Electromagnetic Field Immunity Test (RS) | 49 |
| 9.1 Test Specification | 49 |
| 9.2 Test Instruments | 49 |
| 9.3 Test Arrangement | 50 |
| 9.4 Test Results | 51 |
| 10 Electrical Fast Transient/Burst Immunity Test (EFT)..... | 53 |
| 10.1 Test Specification | 53 |
| 10.2 Test Instruments | 53 |
| 10.3 Test Arrangement | 54 |
| 10.4 Test Results | 55 |
| 11 Surge Immunity Test..... | 57 |

| | | |
|-----------------------------------------------------------------|---------------------------------------------------------------------------|-----------|
| 11.1 | Test Specification | 57 |
| 11.2 | Test Instruments | 57 |
| 11.3 | Test Arrangement | 58 |
| 11.4 | Test Results | 60 |
| 12 | Immunity to Conducted Disturbances Induced by RF Fields (CS) | 62 |
| 12.1 | Test Specification | 62 |
| 12.2 | Test Instruments | 63 |
| 12.3 | Test Arrangement | 64 |
| 12.4 | Test Results | 65 |
| 13 | Pictures of Test Arrangements | 67 |
| 13.1 | Conducted Disturbance at Auxiliary a.c. power ports | 67 |
| 13.2 | Radiated Disturbance up to 1 GHz | 68 |
| 13.3 | Radiated Disturbance above 1 GHz..... | 69 |
| 13.4 | Electrostatic Discharge Immunity Test (ESD) | 70 |
| 13.5 | Radio-frequency, Electromagnetic Field Immunity Test (RS)..... | 72 |
| 13.6 | Electrical Fast Transient/Burst Immunity Test (EFT) | 74 |
| 13.7 | Surge Immunity Test..... | 80 |
| 13.8 | Conducted Disturbances Induced by RF Fields (CS) | 82 |
| Appendix – Information of the Testing Laboratories | | 88 |

Release Control Record

| Issue No. | Description | Date Issued |
|----------------------|------------------|---------------|
| CEAAGC-WTW-P21070535 | Original Release | Mar. 11, 2022 |

2 Summary of Test Results

| EN 50121-3-2:2016, Emission EN 50155:2017, Clause 13.4.8 | | | |
|-------------------------------------------------------------------------------------|---------------------------------------------------------------------------------------------------------------------------------------------------------------|---------------------------------------------------------|---------|
| Port | Test Item / specifications | Result/Remarks | Verdict |
| Auxiliary a.c. or d.c. power ports - Auxiliary supply sinusoidal a.c. or d.c. | Conducted disturbance 150 kHz- 500 kHz: 99 dB μ V quasi-peak 500 kHz- 30 MHz: 93 dB μ V quasi-peak | Minimum passing margin is -43.74 dB at 0.21800 MHz | Pass |
| Auxiliary a.c. or d.c. power ports – AC power outlet port for | Conducted disturbance 50 kHz- 2 kHz: THD<8% (THD: total harmonic distortion) | Test not applicable because the port does not exist. | N/A |
| Battery referenced ports Battery power supply | Conducted disturbance 150 kHz- 500 kHz: 99 dB μ V quasi-peak 500 kHz- 30 MHz: 93 dB μ V quasi-peak | Test not applicable because the port does not exist. | N/A |
| Enclosure | Radiated disturbance 30 MHz- 230 MHz: 40 dB μ V/m quasi-peak 230 MHz -1 GHz: 47 dB μ V/m quasi-peak | Minimum passing margin is -8.97 dB at 212.56 MHz | Pass |
| Enclosure | Radiated disturbance 1 GHz- 3 GHz: 76 dB μ V/m peak 56 dB μ V/m average 3 GHz - 6 GHz: 80 dB μ V/m peak 60 dB μ V/m average | Minimum passing margin is -4.53 dB at 1534.84 MHz | Pass |

EN 50121-3-2:2016, Immunity requirements,
 EN 50155:2017, Clause 13.4.8

| Table Clause | Basic standard | Port | Test Item / specifications | Result/Remarks | Verdict |
|--------------|---------------------------------------------|-------------------------------------------------------------------------------------------------------------------------------------|--------------------------------------------------------------------------------------------------------------------------------------------------------------------------------------------------------------------------------|-------------------------|---------|
| 3.1 | EN 61000-4-6:2014 + AC:2015 | Battery referenced ports (except at the output of energy sources), Auxiliary a.c. power input ports (rated voltage ≤ 400 Vrms) | Radio-frequency common mode (CS) 80% AM (1kHz) 0.15-80 MHz, 10V Performance Criterion A | Performance Criterion A | Pass |
| 3.2 | EN 61000-4-4:2012 | Battery referenced ports (except at the output of energy sources), Auxiliary a.c. power input ports (rated voltage ≤ 400 Vrms) | Fast Transients (EFT) 5/50 (T_r/T_h) ns, 5kHz ± 2 kV Performance Criterion A | Performance Criterion A | Pass |
| 3.3 | EN 61000-4-5:2014 + A1:2017 | Battery referenced ports (except at the output of energy sources), Auxiliary a.c. power input ports (rated voltage ≤ 400 Vrms) | Surges 1.2/50 (8/20) (T_r/T_h) μ s Line to ground: ± 2 kV 42 Ω , 0.5 μ F Line to line: ± 1 kV 42 Ω , 0.5 μ F Performance Criterion B | Performance Criterion B | Pass |
| 4.1 | EN 61000-4-6:2014 + AC:2015 | Signal & communication, process measurement & control ports | Radio-frequency common mode (CS) 80% AM (1kHz) 0.15-80 MHz, 10V Performance Criterion A | Performance Criterion A | Pass |
| 4.2 | EN 61000-4-4:2012 | Signal & communication, process measurement & control ports | Fast Transients (EFT) 5/50 (T_r/T_h) ns, 5kHz ± 2 kV, Capacitive clamp Performance Criterion A | Performance Criterion A | Pass |
| 5.1 | EN 61000-4-3:2006 + A1:2008 + A2:2010 | Enclosure ports | Radio-frequency electromagnetic field amplitude modulated (RS) ¹ , 80% AM (1kHz) 80-800 MHz, 20V/m Performance Criterion A | Performance Criterion A | Pass |
| 5.2 | EN 61000-4-3:2006 + A1:2008 + A2:2010 | Enclosure ports | Radio-frequency electromagnetic field from digital mobile telephones (RS) ² , 80% AM (1kHz) 800-1000 MHz, 20V/m 1400-2000 MHz, 10V/m 2000-2700 MHz, 5V/m 5100-6000 MHz, 3V/m Performance Criterion A | Performance Criterion A | Pass |

EN 50121-3-2:2016, Immunity requirements,
EN 50155:2017, Clause 13.4.8

| Table Clause | Basic standard | Port | Test Item / specifications | Result/Remarks | Verdict |
|--------------|-------------------|-----------------|-----------------------------------------------------------------------------------------------------------|-------------------------|---------|
| 5.3 | EN 61000-4-2:2009 | Enclosure ports | Electrostatic Discharges (ESD) ±6kV Contact discharge ±8kV Air discharge Performance Criterion B | Performance Criterion A | Pass |

Note 1: This limit applies to equipment mounted in the passenger compartments, drivers cab or external to the rolling stock (roof, underframe). For equipment mounted in all other areas a severity level of 10 V/m may be used.

Note 2: For large apparatus (e.g. traction drives, auxiliary converters) it is often not practical to perform the immunity test to radiated electromagnetic fields on the complete unit. In such cases the manufacturer should test susceptible sub-systems (e.g. control electronics). The test report should justify the selection or not of sub-systems and any assumptions made (e.g. reduction of field due to case shielding).

N/A: Not Applicable

Note:

1. There is no deviation to the applied test methods and requirements covered by the scope of this report.
2. The above EN basic standards are applied with latest version if customer has no special requirement.
3. Determining compliance based on the results of the compliance measurement, not taking into account measurement instrumentation uncertainty.

2.1 Performance Criteria

General Performance Criteria

The general performance criteria apply for those ports for which no specific performance criteria are defined (e.g. auxiliary ports) in the report.

Performance criterion A: The apparatus shall continue to operate as intended during and after the test. No degradation of performance or loss of function is allowed below a performance level specified by the manufacturer, when the apparatus is used as intended. The performance level may be replaced by a permissible loss of performance. If the minimum performance level or the permissible performance loss is not specified by the manufacturer, either of these may be derived from the product description and documentation, and from what the user may reasonably expect from the apparatus if used as intended..

Performance criterion B: The apparatus shall continue to operate as intended after the test. No degradation of performance or loss of function is allowed below a performance level specified by the manufacturer, when the apparatus is used as intended. The performance level may be replaced by a permissible loss of performance. During the test, degradation of performance is however allowed. No change of actual operating state or stored data is allowed. If the minimum performance level or the permissible performance loss is not specified by the manufacturer, either of these may be derived from the product description and documentation, and from what the user may reasonably expect from the apparatus if used as intended.

Performance criterion C: Temporary loss of function is allowed, provided the function is selfrecoverable or can be restored by the operation of the controls.

2.2 Measurement Uncertainty

Where relevant, the following measurement uncertainty levels have been estimated for tests performed on the EUT as specified in CISPR 16-4-2:

| Measurement | Expanded Uncertainty (k=2) (\pm) | Maximum allowable uncertainty (\pm) |
|-----------------------------------------------------------------|-----------------------------------------|--------------------------------------------|
| Conducted disturbance at mains port using AMN, 150 kHz ~ 30 MHz | 2.79 dB | 3.4 dB (U_{CISPR}) |
| Radiated disturbance, 30 MHz ~ 1 GHz | 4.73 dB | 6.3 dB (U_{CISPR}) |
| Radiated disturbance, 1 GHz ~ 6 GHz | 5.04 dB | 5.2 dB (U_{CISPR}) |

2.3 Modification Record

There were no modifications required for compliance.

3 General Information

3.1 General Description of EUT

| | |
|---------------------|-------------------------|
| Product | Wireless Gateway/Router |
| Brand | Sierra Wireless, Inc |
| Test Model | XR80 5G |
| Series Model | XR80 LTE Cat-20 |
| Model Difference | Refer to note |
| Status of EUT | Mass product |
| Operating Software | N/A |
| Power Supply Rating | 7-36Vdc |
| Accessory Device | Adapter |
| Data Cable Supplied | N/A |

Note:

1. All models are listed as below. Model XR80 5G is the representative for final test.

| Brand | Model | Description |
|----------------------|-----------------|-----------------------------|
| Sierra Wireless, Inc | XR80 5G | 5G SKU |
| | XR80 LTE Cat-20 | LTE SKU(Remove 5G Function) |

3.2 Features of EUT

The tests reported herein were performed according to the method specified by Sierra Wireless, Inc, for detailed feature description, please refer to the manufacturer's specifications or user's manual.

3.3 Operating Modes of EUT and Determination of Worst Case Operating Mode

The EUT is designed with DC power supply of rating 7-36Vdc.

For Radiated emission test, the EUT has been pre-tested under following test modes, and test mode 3 was the worst case for final test.

| Mode | Test Condition |
|------|--------------------------------------------------------------------------------------------------------------------------------------------------------------------------------|
| 1 | WWAN A WCDMA B1 Link + WWAN B WCDMA B8 Link + LTE Cat M1 B8 Link + WLAN 2.4G+5Gx2 Link + GPS Rx + Type C with Notebook + LAN Link + RS-232 with Notebook + Antenna Link, 12Vdc |
| 2 | WWAN A LTE B1 Link + WWAN B LTE B8 Link + LTE Cat M1 B8 Link + WLAN 2.4G+5Gx2 Link + GPS Rx + Type C with Notebook + LAN Link + RS-232 with Notebook + Antenna Link, 24Vdc |
| 3 | WWAN A LTE B41 Link + WWAN B LTE B46 Link + LTE Cat M1 B8 Link + WLAN 2.4G+5Gx2 Link + GPS Rx + Type C with Notebook + LAN Link + RS-232 with Notebook + Antenna Link, 36Vd |
| 4 | WWAN A 5GNR n78 Link + WWAN B 5GNR n1 Link + LTE Cat M1 B8 Link + WLAN 2.4G+5Gx2 Link + GPS Rx + Type C with Notebook + LAN Link + RS-232 with Notebook + Antenna Link, 36Vd |

For Conducted emission test, the EUT has been pre-tested under following test modes, and test mode 1 was the worst case for final test.

| Mode | Test Condition |
|------|--------------------------------------------------------------------------------------------------------------------------------------------------------------------------------|
| 1 | WWAN A WCDMA B1 Link + WWAN B WCDMA B8 Link + LTE Cat M1 B8 Link + WLAN 2.4G+5Gx2 Link + GPS Rx + Type C with Notebook + LAN Link + RS-232 with Notebook + Antenna Link, 12Vdc |
| 2 | WWAN A LTE B1 Link + WWAN B LTE B8 Link + LTE Cat M1 B8 Link + WLAN 2.4G+5Gx2 Link + GPS Rx + Type C with Notebook + LAN Link + RS-232 with Notebook + Antenna Link, 24Vdc |
| 3 | WWAN A LTE B41 Link + WWAN B LTE B46 Link + LTE Cat M1 B8 Link + WLAN 2.4G+5Gx2 Link + GPS Rx + Type C with Notebook + LAN Link + RS-232 with Notebook + Antenna Link, 36Vd |
| 4 | WWAN A 5GNR n78 Link + WWAN B 5GNR n1 Link + LTE Cat M1 B8 Link + WLAN 2.4G+5Gx2 Link + GPS Rx + Type C with Notebook + LAN Link + RS-232 with Notebook + Antenna Link, 12Vdc |

Test modes are presented in the report as below.

| Mode | Test Condition |
|-------------------------|--------------------------------------------------------------------------------------------------------------------------------------------------------------------------------|
| Conducted emission test | |
| - | WWAN A WCDMA B1 Link + WWAN B WCDMA B8 Link + LTE Cat M1 B8 Link + WLAN 2.4G+5Gx2 Link + GPS Rx + Type C with Notebook + LAN Link + RS-232 with Notebook + Antenna Link, 12Vdc |
| Radiated emission test | |
| - | WWAN A LTE B41 Link + WWAN B LTE B46 Link + LTE Cat M1 B8 Link + WLAN 2.4G+5Gx2 Link + GPS Rx + Type C with Notebook + LAN Link + RS-232 with Notebook + Antenna Link, 36Vd |
| Immunity tests | |
| A | WWAN A WCDMA B1 Link + WWAN B WCDMA B3 Link + LTE Cat M1 B8 Link + WLAN 2.4G+5Gx2 Link + GPS Rx + Type C with Notebook + LAN Link + RS-232 with Notebook + Antenna Link, 12Vdc |
| B | WWAN A LTE B1 Link + WWAN B LTE B3 Link + LTE Cat M1 B8 Link + WLAN 2.4G+5Gx2 Link + GPS Rx + Type C with Notebook + LAN Link + RS-232 with Notebook + Antenna Link, 24Vdc |
| C | WWAN A LTE B41 Link + WWAN B LTE B46 Link + LTE Cat M1 B8 Link + WLAN 2.4G+5Gx2 Link + GPS Rx + Type C with Notebook + LAN Link + RS-232 with Notebook + Antenna Link, 36Vdc |
| D | WWAN A 5GNR n78 Link + WWAN B 5GNR n1 Link + LTE Cat M1 B8 Link + WLAN 2.4G+5Gx2 Link + GPS Rx + Type C with Notebook + LAN Link + RS-232 with Notebook + Antenna Link, 12Vdc |

3.4 Test Program Used and Operation Descriptions

<Emission Tests>

- a. Placed the EUT on the test table and it was powered by DC power supply.
- b. The EUT linked with Notebooks, Radio Communication Analyzer, and GPS, which acted as communication partners, via LAN, WLAN, WWAN and GPS.
- c. EUT sends the "H" signal to the monitor and displays it on the screen.

<Immunity Tests>

- a. Placed the EUT on the test table and it was powered by DC power supply.
- b. The EUT linked with Notebooks, Radio Communication Analyzer, and Base Stations, which acted as communication partners, via LAN, WLAN, WWAN and GPS.

3.5 Primary Clock Frequencies of Internal Source

The highest frequency generated or used within the EUT or on which the EUT operates or tunes is 1600 MHz, provided by Sierra Wireless, Inc., for detailed internal source, please refer to the manufacturer's specifications.

4 Configuration and Connections with EUT

4.1 Connection Diagram of EUT and Peripheral Devices

<Emission Tests>

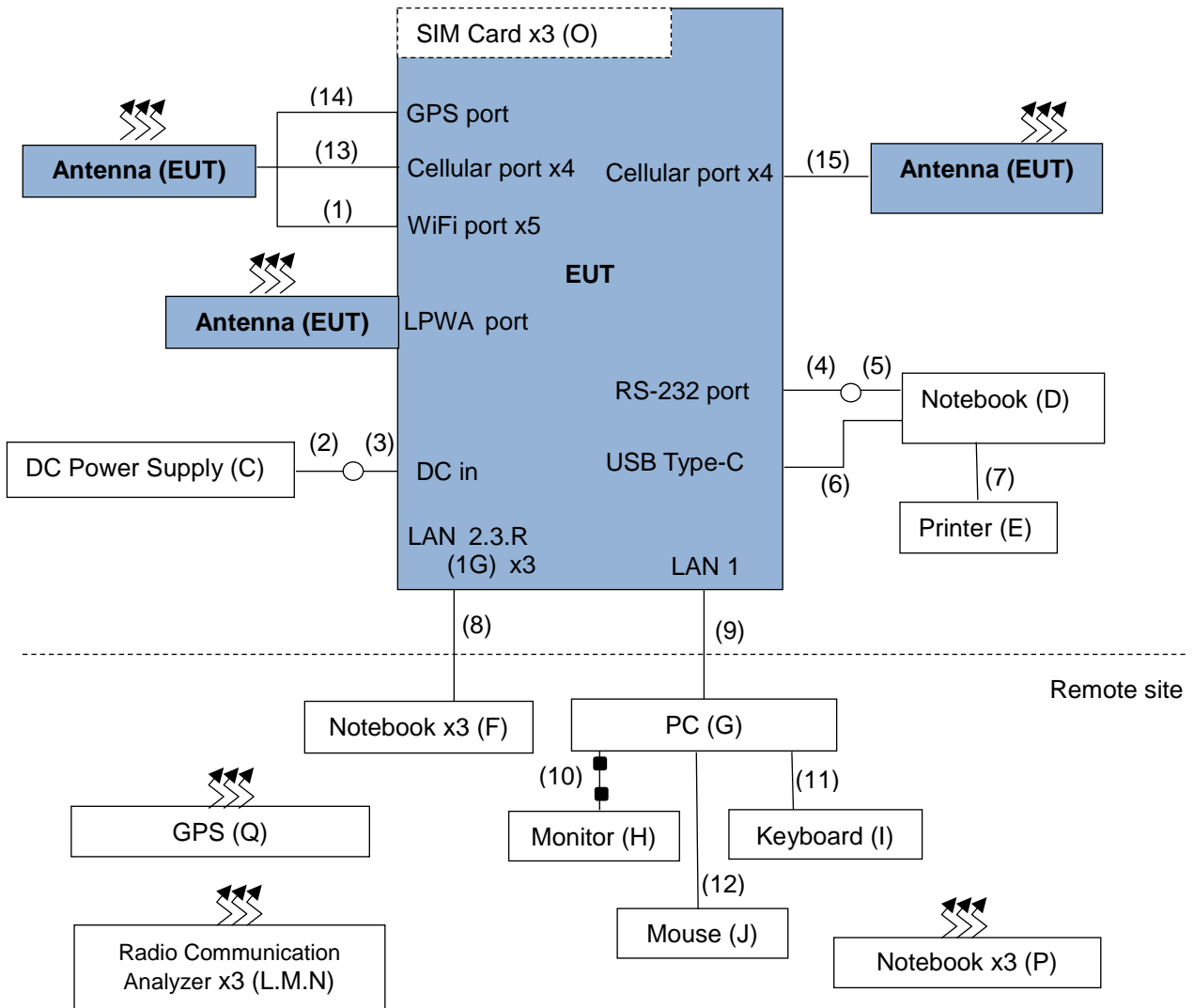

<Immunity Tests>
For Mode A ~ C

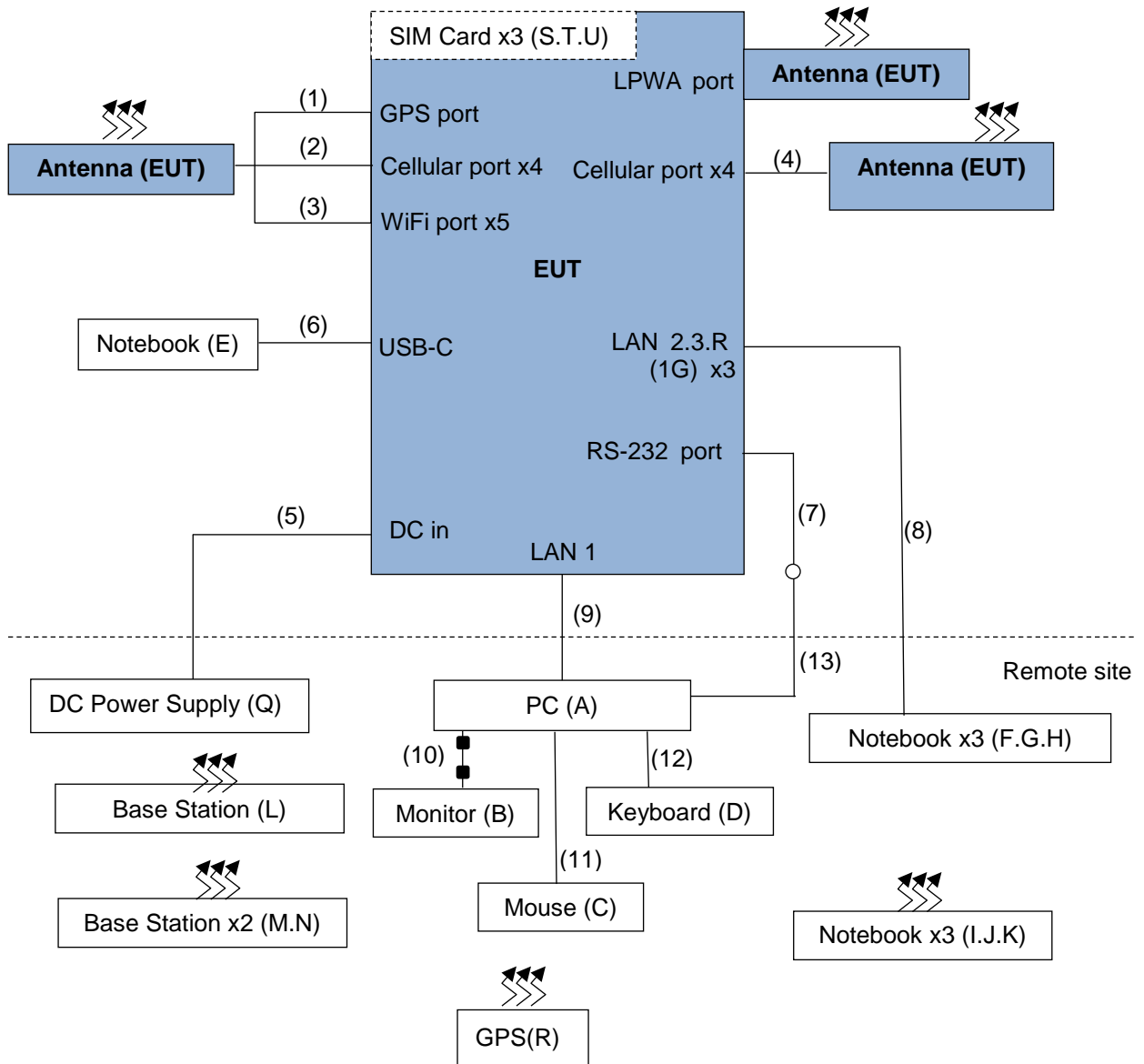

For Mode D

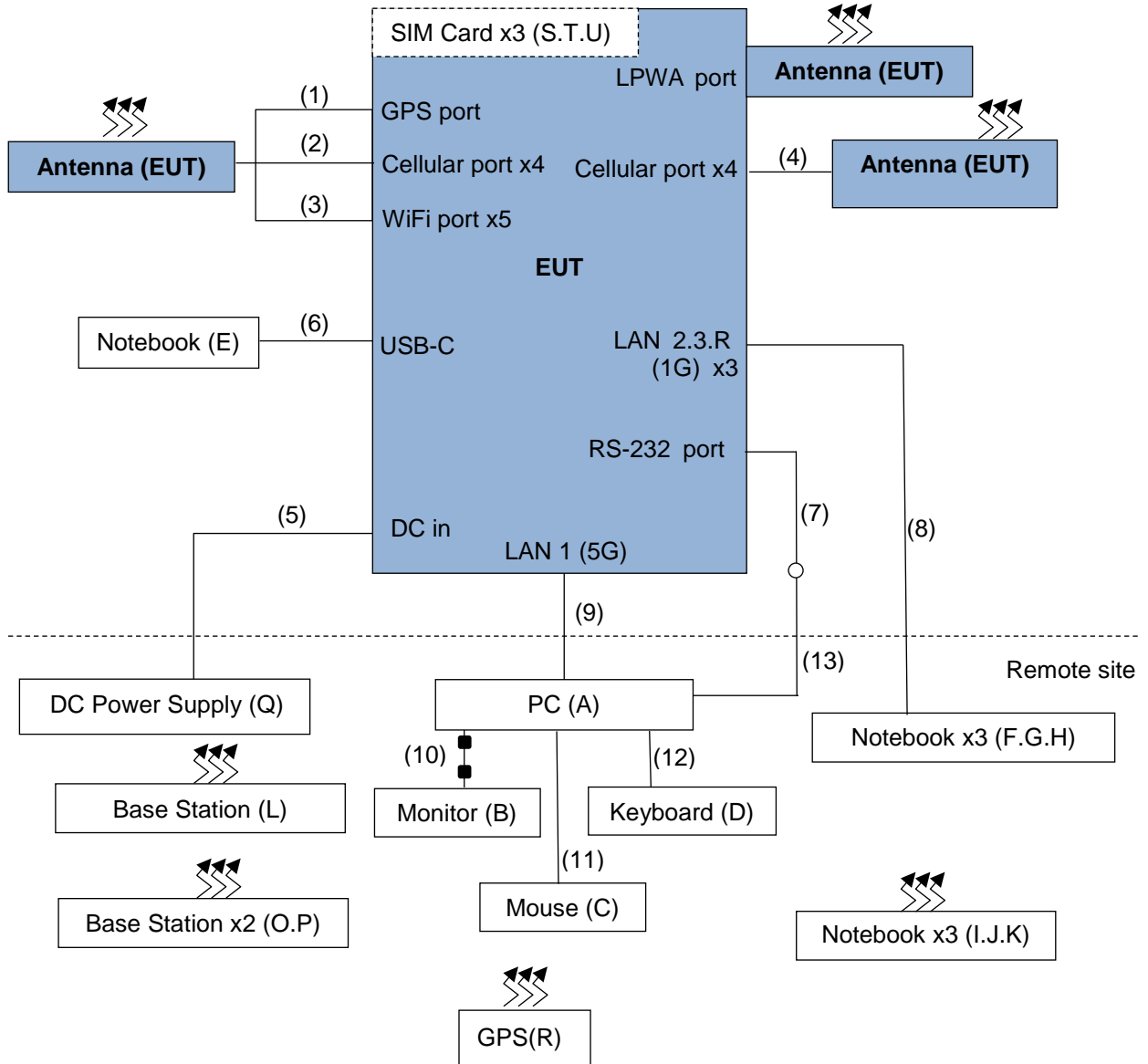

4.2 Configuration of Peripheral Devices and Cable Connections

Emission tests:

| ID | Product | Brand | Model No. | Serial No. | FCC ID | Remarks |
|----|------------------------------|----------|---------------|------------------------------|------------------|---------|
| A. | DC power supply | TOP WARD | 6603A | 725906 | N/A | -- |
| B. | Notebook | DELL | Latitude 5501 | 942VP13 | FCC DoC Approved | -- |
| C. | Printer | EPSON | T22 | MEEZ070220 | FCC DoC Approved | -- |
| D. | Notebook | DELL | E6440 | 6QLNM32 | PD92230BNHU | -- |
| | | DELL | E6440 | FMLNM32 | FCC DoC Approved | -- |
| | | DELL | E6440 | FNLNM32 | FCC DoC Approved | -- |
| E. | PC | ASUS | D520MT | G8PFAG000VZU | FCC DoC Approved | -- |
| F. | Monitor | DELL | U2410 | CN-0J257M-72872-0A6-02YL | FCC DoC Approved | -- |
| G. | Keyboard | DELL | KB216t | CN-0W33XP-LO300-79R-OUG7-A03 | FCC DoC Approved | -- |
| H. | Mouse | DELL | MOCZUL | CN-049TWY-PRC00-79E-02FW | FCC DoC Approved | -- |
| I. | Radio Communication Analyzer | Keysight | E7515B | MY58300759 | N/A | -- |
| J. | Radio Communication Analyzer | Anritsu | MT8820C | 6201010284 | N/A | -- |
| K. | Radio Communication Analyzer | Anritsu | MT8821C | 6261806803 | N/A | -- |
| L. | SIM card | R&S | N/A | N/A | N/A | -- |
| | | R&S | N/A | N/A | N/A | |
| | | R&S | N/A | N/A | N/A | |
| M. | Notebook | DELL | Latitude 5501 | F42VP13 | FCC DoC Approved | -- |
| | | DELL | Latitude 5501 | 942VP13 | FCC DoC Approved | |
| | | DELL | E6440 | FMLNM32 | FCC DoC Approved | |
| N. | GPS | PENDULUM | GSG-54 | 191121 | N/A | -- |

Note:

1. All power cords of the above support units are non-shielded (1.8m).
2. Items D-K, M, N acted as communication partners to transfer data.

| ID | Cable Descriptions | Qty. | Length (m) | Shielding (Yes/No) | Cores (Qty.) | Remarks |
|-----|--------------------|------|------------|--------------------|--------------|-----------------------|
| 1. | Antenna cable | 5 | 5 | Yes | 0 | Accessory of EUT |
| 2. | DC cable | 1 | 3.02 | No | 0 | Supplied by Applicant |
| 3. | DC cable | 1 | 0.5 | Yes | 0 | -- |
| 4. | RS-232 cable | 1 | 1.8 | Yes | 0 | LAN to RS-232 |
| 5. | RS-232 cable | 1 | 1.8 | Yes | 0 | RS-232 to LAN |
| 6. | USB-C cable | 1 | 1 | Yes | 0 | -- |
| 7. | USB cable | 1 | 1.8 | Yes | 0 | -- |
| 8. | LAN cable | 3 | 10 | No | 0 | RJ45 Cat.5e |
| 9. | LAN cable | 1 | 10 | No | 0 | RJ45 Cat.6a |
| 10. | VGA cable | 1 | 1.8 | Yes | 2 | -- |
| 11. | USB cable | 1 | 1.8 | Yes | 0 | -- |
| 12. | USB cable | 1 | 1.8 | Yes | 0 | -- |
| 13. | Antenna cable | 4 | 5 | Yes | 0 | Accessory of EUT |
| 14. | Antenna cable | 1 | 5 | Yes | 0 | Accessory of EUT |
| 15. | Antenna cable | 4 | 5 | Yes | 0 | Accessory of EUT |

Note: The core(s) is (are) originally attached to the cable(s).

Immunity tests:

| ID | Product | Brand | Model No. | Serial No. | FCC ID | Remarks |
|----|-----------------|----------|---------------|------------------------------|------------------|---------|
| A. | PC | DELL | Optuplex 9010 | N/A | FCC DoC Approved | -- |
| B. | Monitor | CHIMEI | 96VD | N/A | FCC DoC Approved | -- |
| C. | Mouse | HP | m100 | N/A | FCC DoC Approved | -- |
| D. | Keyboard | DELL | KB4021 | CN-05V23T-71581-1AK-01S2-A01 | FCC DoC Approved | -- |
| E. | Notebook | Lenovo | X240 | PC03JG66 | FCC DoC Approved | -- |
| F. | Notebook | DELL | E5430 | FKKCYW1 | FCC DoC Approved | -- |
| G. | Notebook | DELL | E5440 | D920P32 | FCC DoC Approved | -- |
| H. | Notebook | DELL | E6440 | 5033M12 | FCC DoC Approved | -- |
| I. | Notebook | DELL | P60F | 1C0YHR2 | FCC DoC Approved | -- |
| J. | Notebook | DELL | P60F | 98JKMQ2 | FCC DoC Approved | -- |
| K. | Notebook | DELL | E5430 | FRHRNX1 | FCC DoC Approved | -- |
| L. | Base Station | Anritsu | MT8821C | 6261806803 | N/A | -- |
| M. | Base Station | Anritsu | MT8820C | 6201240432 | N/A | -- |
| N. | Base Station | Anritsu | MT8820C | 6201240431 | N/A | -- |
| O. | Base Station | Anritsu | MT8000A | 6262012865 | N/A | -- |
| P. | Base Station | Keysight | E7515B | MY58300759 | N/A | -- |
| Q. | DC Power Supply | Chroma | 62024P-80-60 | N/A | N/A | -- |
| R. | GPS | Pendulum | GSG-54 | 191121 | N/A | -- |
| S. | SIM Card | Anritsu | N/A | N/A | N/A | -- |
| T. | SIM Card | Anritsu | N/A | N/A | N/A | -- |
| U. | SIM Card | R&S | N/A | N/A | N/A | -- |

Note:

1. All power cords of the above support units are non-shielded (1.8m).
2. Items A-D, F-R acted as communication partners to transfer data.

| ID | Cable Descriptions | Qty. | Length (m) | Shielding (Yes/No) | Cores (Qty.) | Remarks |
|-----|--------------------|------|------------|--------------------|--------------|-----------------------|
| 1. | Antenna cable | 1 | 5 | Yes | 0 | Accessory of EUT |
| 2. | Antenna cable | 4 | 5 | Yes | 0 | Accessory of EUT |
| 3. | Antenna cable | 5 | 5 | Yes | 0 | Accessory of EUT |
| 4. | Antenna cable | 4 | 5 | Yes | 0 | Accessory of EUT |
| 5. | Power cable | 1 | 3.02 | No | 0 | Supplied by Applicant |
| 6. | USB-C cable | 1 | 0.8 | Yes | 0 | -- |
| 7. | RS-232 cable | 1 | 1.5 | No | 0 | -- |
| 8. | LAN cable | 3 | 3 | No | 0 | RJ45 Cat.5e |
| 9. | LAN cable | 1 | 3 | No | 0 | RJ45 Cat.5a |
| 10. | D-Sub cable | 1 | 1.8 | Yes | 2 | -- |
| 11. | USB cable | 1 | 1.5 | Yes | 0 | -- |
| 12. | USB cable | 1 | 1.5 | Yes | 0 | -- |
| 13. | Console cable | 1 | 1.8 | No | 0 | -- |

Note: The core(s) is (are) originally attached to the cable(s).

5 Conducted Disturbance at Auxiliary a.c. Power Ports

5.1 Limits

| Frequency (MHz) | Quasi-peak, (dBuV) |
|-----------------|--------------------|
| 0.15 - 0.5 | 99 |
| 0.5 - 30 | 93 |

Notes: 1. The lower limit shall apply at the transition frequencies.
 2. The limit decreases linearly with the logarithm of the frequency in the range of 0.15 to 0.50 MHz.

5.2 Test Instruments

| Description & Manufacturer | Model No. | Serial No. | Cal. Date | Cal. Due |
|---------------------------------------------|--------------------------|----------------|---------------|---------------|
| Test Receiver ROHDE & SCHWARZ | ESR3 | 102783 | Jan. 29, 2021 | Jan. 28, 2022 |
| RF signal cable (with 10dB PAD) Woken | 5D-FB | Cable-cond2-01 | Sep. 04, 2021 | Sep. 03, 2022 |
| LISN R&S | ENV216 | 101196 | Apr. 26, 2021 | Apr. 25, 2022 |
| LISN/AMN ROHDE & SCHWARZ (Peripheral) | ESH3-Z5 | 100312 | Sep. 17, 2021 | Sep. 16, 2022 |
| Software ADT | BV ADT_Cond_ V7.3.7.3 | NA | NA | NA |

Note: 1. The calibration interval of the above test instruments is 12 months and the calibrations are traceable to NML/ROC and NIST/USA.
 2. The test was performed in HwaYa Shielded Room 2 (Conduction 2).
 3. The VCCI Site Registration No. is C-12047.
 4. Test Date: 2022/01/03.

5.3 Test Arrangement

- The EUT was placed 0.4 meters from the conducting wall of the shielded room with EUT being connected to the power mains through a line impedance stabilization network (LISN). Other support units were connected to the power mains through another LISN. The two LISNs provide 50 Ohm/ 50uH of coupling impedance for the measuring instrument.
- Both lines of the power mains connected to the EUT were checked for maximum conducted interference.
- The test results of conducted emissions at mains ports are recorded of six worst margins for quasi-peak (mandatory) [and average (if necessary)] values against the limits at frequencies of interest unless the margin is 20 dB or greater.

Note: The resolution bandwidth and video bandwidth of test receiver is 9kHz for quasi-peak detection (QP) and average detection (AV) at frequency 0.15MHz-30MHz.

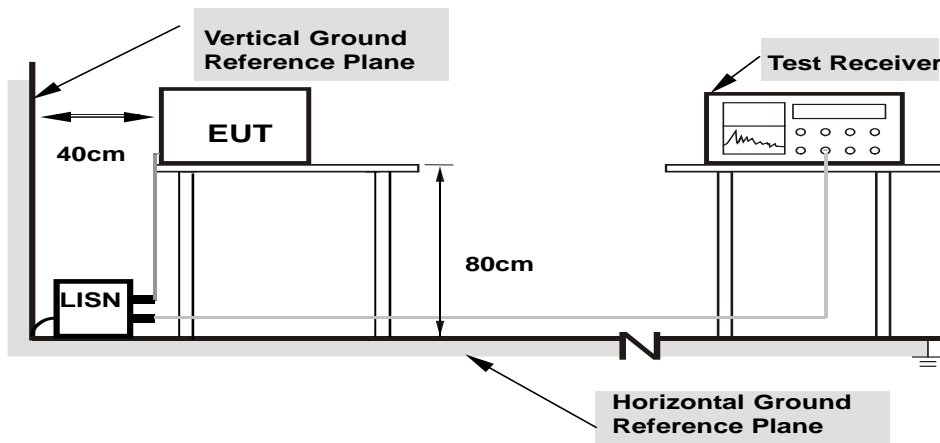

- Note:**
- Support units were connected to second LISN.
 - Both of LISNs (AMN) are 80 cm from EUT and at least 80 cm from other units and other metal planes

5.4 Test Results

| | | | |
|------------------------|------------------|-----------------------------------------------------|-----------------------|
| Frequency Range | 150 kHz ~ 30 MHz | Detector Function & Resolution Bandwidth | Quasi-Peak (QP), 9kHz |
| Input Power | 12 Vdc | Environmental Conditions | 22 °C, 72 % RH |
| Tested by | Jim Lee | | |

| No | Frequency (MHz) | Correction Factor (dB) | Reading Value (dBuV) | Emission Level (dBuV) | Limit (dBuV) | Margin (dB) |
|----|-----------------|------------------------|----------------------|-----------------------|--------------|-------------|
| | | | Q.P. | Q.P. | Q.P. | Q.P. |
| 1 | 0.20095 | 10.08 | 40.44 | 50.52 | 99.00 | -48.48 |
| 2 | 0.22200 | 10.08 | 44.57 | 54.65 | 99.00 | -44.35 |
| 3 | 1.01000 | 10.06 | 32.02 | 42.08 | 93.00 | -50.92 |
| 4 | 1.44189 | 10.06 | 33.32 | 43.38 | 93.00 | -49.62 |
| 5 | 3.77000 | 10.07 | 28.48 | 38.55 | 93.00 | -54.45 |
| 6 | 4.72600 | 10.07 | 29.32 | 39.39 | 93.00 | -53.61 |

Remarks:

1. Q.P. is abbreviations of quasi-peak individually.
2. The emission levels of other frequencies were very low against the limit.
3. Margin value = Emission level – Limit value
4. Correction factor = Insertion loss + Cable loss
5. Emission Level = Correction Factor + Reading Value

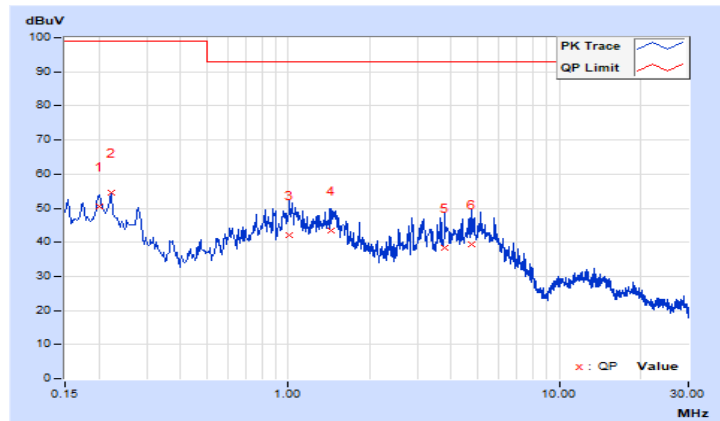

| | | | |
|------------------------|------------------|-----------------------------------------------------|-----------------------|
| Frequency Range | 150 kHz ~ 30 MHz | Detector Function & Resolution Bandwidth | Quasi-Peak (QP), 9kHz |
| Input Power | 12 Vdc | Environmental Conditions | 22 °C, 72 % RH |
| Tested by | Jim Lee | | |

| No | Frequency (MHz) | Correction Factor (dB) | Reading Value (dBuV) | Emission Level (dBuV) | Limit (dBuV) | Margin (dB) |
|----|-----------------|------------------------|----------------------|-----------------------|--------------|-------------|
| | | | Q.P. | Q.P. | Q.P. | Q.P. |
| 1 | 0.21800 | 10.07 | 45.19 | 55.26 | 99.00 | -43.74 |
| 2 | 0.27400 | 10.06 | 41.17 | 51.23 | 99.00 | -47.77 |
| 3 | 0.88200 | 10.05 | 33.38 | 43.43 | 93.00 | -49.57 |
| 4 | 3.35800 | 10.06 | 30.45 | 40.51 | 93.00 | -52.49 |
| 5 | 4.35400 | 10.06 | 31.02 | 41.08 | 93.00 | -51.92 |
| 6 | 4.90200 | 10.06 | 31.42 | 41.48 | 93.00 | -51.52 |

Remarks:

1. Q.P. is abbreviations of quasi-peak individually.
2. The emission levels of other frequencies were very low against the limit.
3. Margin value = Emission level – Limit value
4. Correction factor = Insertion loss + Cable loss
5. Emission Level = Correction Factor + Reading Value

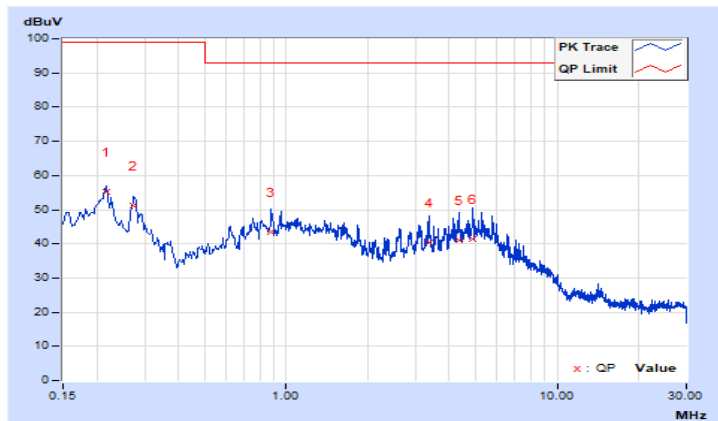

6 Radiated Disturbance up to 1 GHz

6.1 Limits

| Frequency (MHz) | dBuV/m (at 10m) / quasi-peak |
|-----------------|------------------------------|
| 30 - 230 | 40 |
| 230 - 1000 | 47 |

- Notes:
1. The lower limit shall apply at the transition frequencies.
 2. Emission level (dBuV/m) = 20 log Emission level (uV/m).
 3. All emanations from a class A/B digital device or system, including any network of conductors and apparatus connected thereto, shall not exceed the level of field strengths specified above.

6.2 Test Instruments

| Description & Manufacturer | Model No. | Serial No. | Cal. Date | Cal. Due |
|------------------------------|----------------------|--------------|---------------|---------------|
| Software BVADT | ADT_Radiated_V8.7.08 | NA | NA | NA |
| Antenna Tower BVADT | AT100 | AT93021702 | NA | NA |
| Turn Table BVADT | TT100 | TT93021702 | NA | NA |
| Controller BVADT | SC100 | SC93021702 | NA | NA |
| Test Receiver ESR7 R&S | ESR7 | 101471 | Mar. 15, 2021 | Mar. 14, 2022 |
| Bi_Log Antenna Schwarbeck | VULB9168 | 9168-149 | Oct. 29, 2021 | Oct. 28, 2022 |
| RF Coaxial Cable TIMES | LMR-400 (18M) | CABLE-CH2-01 | Mar. 22, 2021 | Mar. 21, 2022 |
| Pre_Amplifier Agilent | 8447D | 2944A10629 | Mar. 22, 2021 | Mar. 21, 2022 |

- Notes:
1. The calibration interval of the above test instruments is 12 months and the calibrations are traceable to NML/ROC and NIST/USA.
 2. The test was performed in HwaYa Chamber 2 (966 Chamber 1).
 3. The VCCI Site Registration No. is R-20018.
 4. Test Date: 2021/12/29.

6.3 Test Arrangement

- The EUT was placed on the top of a rotating table 0.8 meters above the ground at an accredited test facility. The table was rotated 360 degrees to determine the position of the highest radiation.
- The EUT was set 3 meters away from the interference-receiving antenna, which was mounted on the top of a variable-height antenna tower.
- The antenna is a broadband antenna, and its height is varied from one meter to four meters above the ground to determine the maximum value of the field strength. Both horizontal and vertical polarizations of the antenna are set to make the measurement.
- For each suspected emission, the EUT was arranged to its worst case and then the antenna was tuned to heights from 1 meter to 4 meters and the rotatable table was turned from 0 degrees to 360 degrees to find the maximum reading.
- The test-receiver system was set to quasi-peak detect function and specified bandwidth with maximum hold mode when the test frequency is up to 1 GHz.

Note: The resolution bandwidth and video bandwidth of test receiver/spectrum analyzer is 120 kHz for quasi-peak detection (QP) at frequency up to 1 GHz.

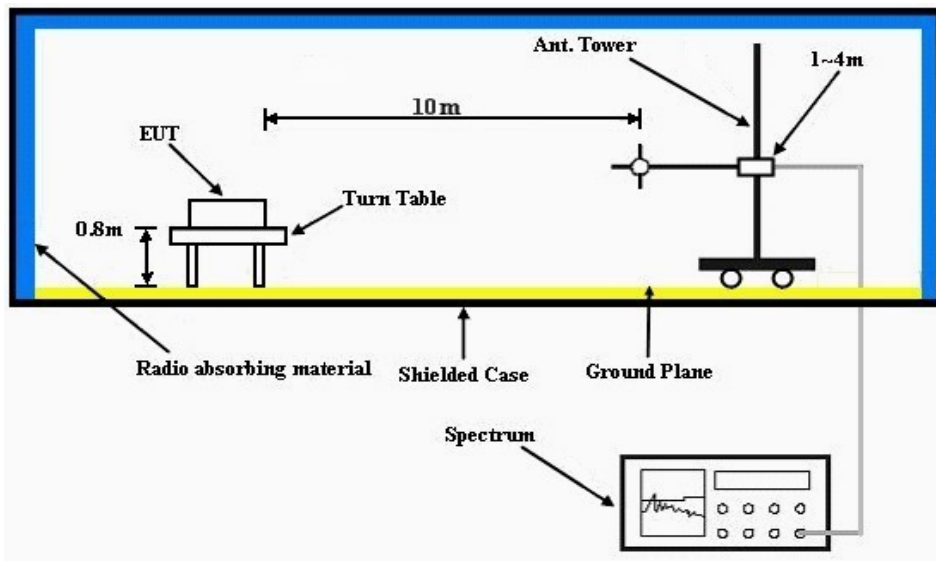

6.4 Test Results

| | | | |
|------------------------|--------------|-----------------------------------------------------|-------------------------|
| Frequency Range | 30MHz ~ 1GHz | Detector Function & Resolution Bandwidth | Quasi-Peak (QP), 120kHz |
| Tested By | Rolan Zheng | Environmental Conditions | 24 °C, 69 % RH |

| Antenna Polarity & Test Distance : Horizontal at 10 m | | | | | | | | |
|-------------------------------------------------------|-----------------|-------------------------|----------------|--------------|--------------------|----------------------|------------------|--------------------------|
| No | Frequency (MHz) | Emission Level (dBuV/m) | Limit (dBuV/m) | Margin (dB) | Antenna Height (m) | Table Angle (Degree) | Raw Value (dBuV) | Correction Factor (dB/m) |
| 1 | 35.38 | 37.99 QP | 50.00 | -12.01 | 2.00 H | 340 | 48.71 | -10.72 |
| 2 | 119.88 | 35.46 QP | 50.00 | -14.54 | 1.50 H | 149 | 47.05 | -11.59 |
| 3 | 212.56 | 41.03 QP | 50.00 | -8.97 | 1.50 H | 185 | 52.75 | -11.72 |
| 4 | 263.78 | 38.67 QP | 57.00 | -18.33 | 1.00 H | 185 | 47.65 | -8.98 |
| 5 | 454.93 | 42.89 QP | 57.00 | -14.11 | 1.50 H | 124 | 47.86 | -4.97 |
| 6 | 490.09 | 45.00 QP | 57.00 | -12.00 | 1.00 H | 135 | 49.49 | -4.49 |
| 7 | 544.81 | 40.75 QP | 57.00 | -16.25 | 1.50 H | 169 | 44.33 | -3.58 |
| 8 | 660.53 | 43.22 QP | 57.00 | -13.78 | 1.00 H | 177 | 44.45 | -1.23 |

Remarks:

1. Emission Level(dBuV/m) = Raw Value(dBuV) + Correction Factor(dB/m)
2. Correction Factor(dB/m) = Antenna Factor (dB/m) + Cable Factor (dB) – Pre-Amplifier Factor (dB)
3. The other emission levels were very low against the limit.
4. Margin value = Emission level – Limit value

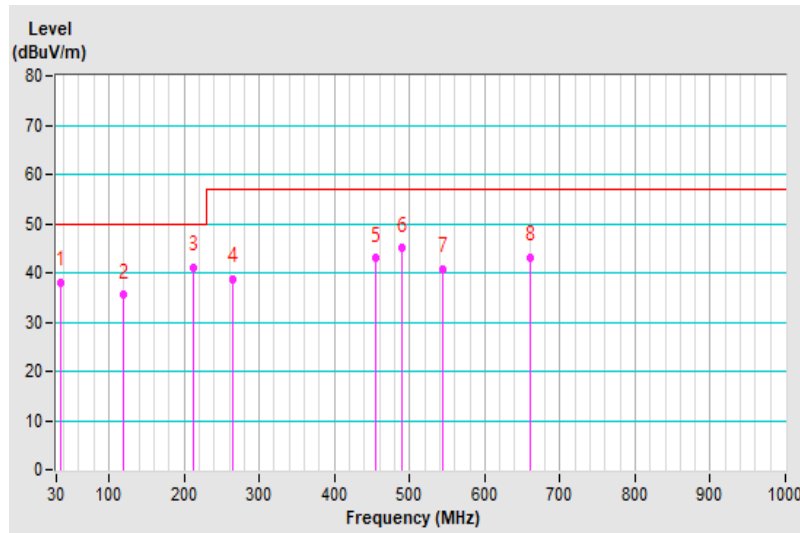

| | | | |
|------------------------|--------------|-----------------------------------------------------|-------------------------|
| Frequency Range | 30MHz ~ 1GHz | Detector Function & Resolution Bandwidth | Quasi-Peak (QP), 120kHz |
| Tested By | Rolan Zheng | Environmental Conditions | 24 °C, 69 % RH |

| Antenna Polarity & Test Distance : Vertical at 10 m | | | | | | | | |
|-----------------------------------------------------|-----------------|-------------------------|----------------|-------------|--------------------|----------------------|------------------|--------------------------|
| No | Frequency (MHz) | Emission Level (dBuV/m) | Limit (dBuV/m) | Margin (dB) | Antenna Height (m) | Table Angle (Degree) | Raw Value (dBuV) | Correction Factor (dB/m) |
| 1 | 41.59 | 39.36 QP | 50.00 | -10.64 | 2.50 V | 328 | 49.12 | -9.76 |
| 2 | 147.23 | 37.82 QP | 50.00 | -12.18 | 1.00 V | 163 | 46.69 | -8.87 |
| 3 | 198.40 | 37.20 QP | 50.00 | -12.80 | 1.00 V | 13 | 49.06 | -11.86 |
| 4 | 486.41 | 43.92 QP | 57.00 | -13.08 | 1.50 V | 186 | 48.54 | -4.62 |
| 5 | 547.04 | 42.82 QP | 57.00 | -14.18 | 1.00 V | 194 | 46.35 | -3.53 |
| 6 | 664.46 | 43.41 QP | 57.00 | -13.59 | 1.00 V | 272 | 44.50 | -1.09 |
| 7 | 900.38 | 47.70 QP | 57.00 | -9.30 | 1.00 V | 81 | 44.50 | 3.20 |

Remarks:

1. Emission Level(dBuV/m) = Raw Value(dBuV) + Correction Factor(dB/m)
2. Correction Factor(dB/m) = Antenna Factor (dB/m) + Cable Factor (dB) – Pre-Amplifier Factor (dB)
3. The other emission levels were very low against the limit.
4. Margin value = Emission level – Limit value

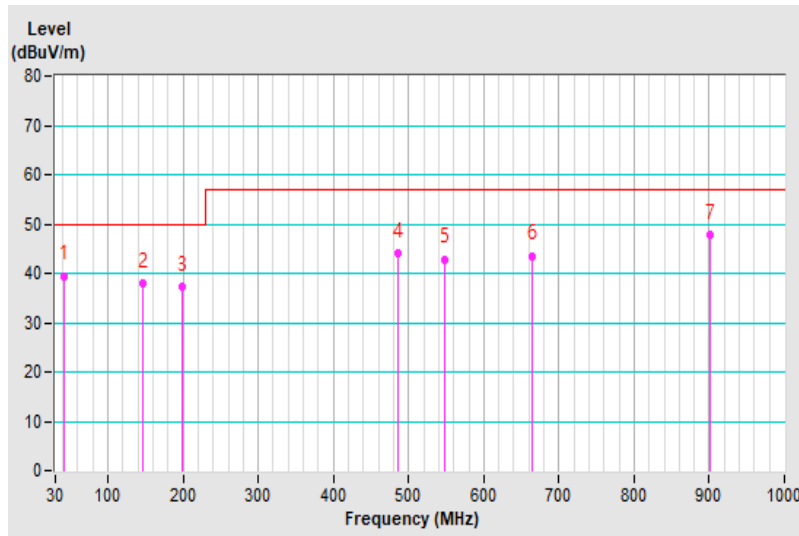

7 Radiated Disturbance above 1 GHz

7.1 Limits

| Frequency (GHz) | (dBuV/m) (at 3 m) | |
|-----------------|-------------------|------|
| | Average | Peak |
| 1 to 3 | 56 | 76 |
| 3 to 6 | 60 | 80 |

Notes:

1. The lower limit shall apply at the transition frequencies.
2. Emission level (dBuV/m) = 20 log Emission level (uV/m).
3. All emanations from a class A/B digital device or system, including any network of conductors and apparatus connected thereto, shall not exceed the level of field strengths specified above.

Frequency Range (For unintentional radiators)

| Highest frequency generated or used in the EUT or on which the EUT operates or tunes (MHz) | Upper frequency of measurement range (MHz) |
|--------------------------------------------------------------------------------------------|--------------------------------------------------------------------|
| Below 108 | 1000 |
| 108-500 | 2000 |
| 500-1000 | 5000 |
| Above 1000 | Up to 5 times of the highest frequency or 6 GHz, whichever is less |

7.2 Test Instruments

| Description & Manufacturer | Model No. | Serial No. | Cal. Date | Cal. Due |
|--------------------------------------------|-------------------------------|---------------------------------------------|---------------|---------------|
| Spectrum Analyzer Agilent | E4446A | MY51100039 | Dec. 07, 2021 | Dec. 06, 2022 |
| PXA S Analyzer KEYSIGHT | N9030B | MY57141885 | Jun. 07, 2021 | Jun. 06, 2022 |
| BILOG Antenna SCHWARZBECK | VULB9168 | 9168-149 | Oct. 29, 2021 | Oct. 28, 2022 |
| RF signal cable (with 5dB PAD) Times | LMR-400 (18M) | CABLE-CH2-01 | Mar. 22, 2021 | Mar. 21, 2022 |
| HORN Antenna (with 4dB PAD) SCHWARZBECK | BBHA 9120 D | 9120D-405 | Nov. 14, 2021 | Nov. 13, 2022 |
| Pre-Amplifier Agilent (Above 1GHz) | 8449B | 3008A01961 | Sep. 04, 2021 | Sep. 03, 2022 |
| Software BV ADT | BV ADT_Radiated_ V8.7.08 | NA | NA | NA |
| Antenna Tower BV ADT | AT100 | AT93021702 | NA | NA |
| Turn Table BV ADT | TT100 | TT93021702 | NA | NA |
| Controller BV ADT | SC100 | SC93021702 | NA | NA |
| BandPass Filter (2.4G) MICRO-TRONICS | BRM17690-01 | 003 | Sep. 04, 2021 | Sep. 03, 2022 |
| BandPass Filter (5G) MICRO-TRONICS | BRM50716-01 | G011 | Sep. 04, 2021 | Sep. 03, 2022 |
| RF Coaxial Cable EMCI | EMC102-KM-KM-1000 | 170819 | Sep. 04, 2021 | Sep. 03, 2022 |
| RF Coaxial Cable Rosnol | K1K50-UP0279- K1K50-3000 | 181129-1 | Sep. 04, 2021 | Sep. 03, 2022 |
| RF Coaxial Cable JUNFLON+EMC | JUNFLON+EMC104- SM-SM-6000 | Cable-CH2- 02(MWX3221308 G003+130710) | Jan. 16, 2021 | Jan. 15, 2022 |
| Fix tool for Boresight antenna | BAF-01 | 2 | NA | NA |

Notes: 1. The calibration interval of the above test instruments is 12 months and the calibrations are traceable to NML/ROC and NIST/USA.

2. The 3 dB beamwidth of the horn antenna is minimum 30 degree (or $w = 1.6$ m at 3 m distance) for 1~6 GHz.

3. The test was performed in HwaYa Chamber 2 (966 Chamber 1).

4. The VCCI Site Registration No. is G-10018.

5. Test Date: 2021/12/29.

7.3 Test Arrangement

- The EUT was placed on the top of a rotating table 0.8 meters above the ground at an accredited chamber room.
- The EUT was set 3 meters away from the interference-receiving antenna, which was mounted on the top of a variable-height antenna tower.
- The height of antenna can be varied from one meter to four meters, the height of adjustment depends on the EUT height and the antenna 3 dB beamwidth both, to detect the maximum value of the field strength. Both horizontal and vertical polarizations of the antenna are set to make the measurement.
- For each suspected emission, the EUT was arranged to its worst case and then the antenna was tuned to heights and the rotatable table was turned from 0 degrees to 360 degrees to find the maximum reading.
- The spectrum analyzer system was set to peak and average detect function and specified bandwidth with maximum hold mode when the test frequency is above 1 GHz.

Note: The resolution bandwidth of test receiver/spectrum analyzer is 1 MHz and video bandwidth is 3 MHz for Peak detection (PK) at frequency above 1 GHz. The resolution bandwidth of test receiver/spectrum analyzer is 1 MHz for Average detection (AV) at frequency above 1 GHz.

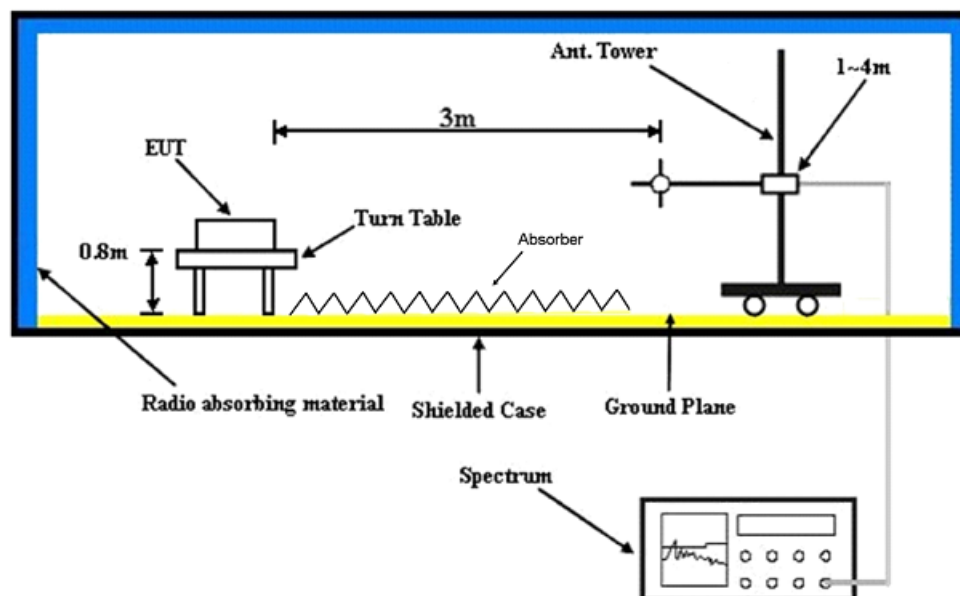

7.4 Test Results

| | | | |
|------------------------|-------------|-----------------------------------------------------|--------------------------------|
| Frequency Range | 1GHz ~ 6GHz | Detector Function & Resolution Bandwidth | Peak (PK) / Average (AV), 1MHz |
| Tested By | Rolan Zheng | Environmental Conditions | 24 °C, 69 % RH |

| Antenna Polarity & Test Distance : Horizontal at 3 m | | | | | | | | |
|------------------------------------------------------|-----------------|-------------------------|----------------|-------------|--------------------|----------------------|------------------|--------------------------|
| No | Frequency (MHz) | Emission Level (dBuV/m) | Limit (dBuV/m) | Margin (dB) | Antenna Height (m) | Table Angle (Degree) | Raw Value (dBuV) | Correction Factor (dB/m) |
| 1 | 1534.85 | 50.76 PK | 76.00 | -25.24 | 1.00 H | 203 | 52.89 | -2.13 |
| 2 | 1534.85 | 48.36 AV | 56.00 | -7.64 | 1.00 H | 203 | 50.49 | -2.13 |
| 3 | 2216.97 | 47.14 PK | 76.00 | -28.86 | 1.39 H | 2 | 43.16 | 3.98 |
| 4 | 2216.97 | 32.22 AV | 56.00 | -23.78 | 1.39 H | 2 | 28.24 | 3.98 |
| 5 | 2934.86 | 46.58 PK | 76.00 | -29.42 | 1.68 H | 72 | 41.60 | 4.98 |
| 6 | 2934.86 | 32.58 AV | 56.00 | -23.42 | 1.68 H | 72 | 27.60 | 4.98 |

Remarks:

1. Emission Level(dBuV/m) = Raw Value(dBuV) + Correction Factor(dB/m)
2. Correction Factor(dB/m) = Antenna Factor (dB/m) + Cable Factor (dB) – Pre-Amplifier Factor (dB)
3. The other emission levels were very low against the limit.
4. Margin value = Emission level – Limit value

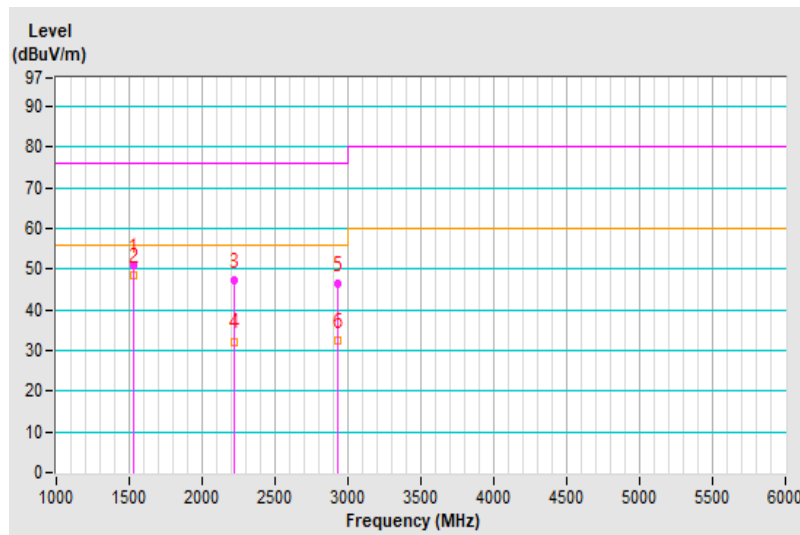

| | | | |
|------------------------|-------------|-----------------------------------------------------|--------------------------------|
| Frequency Range | 1GHz ~ 6GHz | Detector Function & Resolution Bandwidth | Peak (PK) / Average (AV), 1MHz |
| Tested By | Rolan Zheng | Environmental Conditions | 24 °C, 69 % RH |

| Antenna Polarity & Test Distance : Vertical at 3 m | | | | | | | | |
|----------------------------------------------------|-----------------|-------------------------|----------------|--------------|--------------------|----------------------|------------------|--------------------------|
| No | Frequency (MHz) | Emission Level (dBuV/m) | Limit (dBuV/m) | Margin (dB) | Antenna Height (m) | Table Angle (Degree) | Raw Value (dBuV) | Correction Factor (dB/m) |
| 1 | 1534.84 | 53.34 PK | 76.00 | -22.66 | 1.02 V | 145 | 55.47 | -2.13 |
| 2 | 1534.84 | 51.47 AV | 56.00 | -4.53 | 1.02 V | 145 | 53.60 | -2.13 |
| 3 | 1992.72 | 50.92 PK | 76.00 | -25.08 | 1.63 V | 258 | 50.22 | 0.70 |
| 4 | 1992.72 | 33.17 AV | 56.00 | -22.83 | 1.63 V | 258 | 32.47 | 0.70 |
| 5 | 2279.23 | 48.95 PK | 76.00 | -27.05 | 1.76 V | 214 | 45.90 | 3.05 |
| 6 | 2279.23 | 36.21 AV | 56.00 | -19.79 | 1.76 V | 214 | 33.16 | 3.05 |

Remarks:

1. Emission Level(dBuV/m) = Raw Value(dBuV) + Correction Factor(dB/m)
2. Correction Factor(dB/m) = Antenna Factor (dB/m) + Cable Factor (dB)
– Pre-Amplifier Factor (dB)
3. The other emission levels were very low against the limit.
4. Margin value = Emission level – Limit value

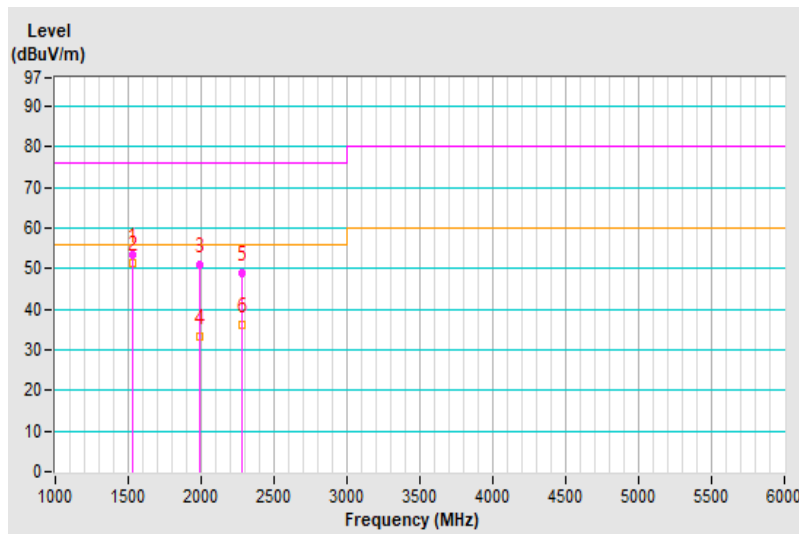

8 Electrostatic Discharge Immunity Test (ESD)

8.1 Test Specification

| | |
|----------------------|-------------------------------------------------------------------------------------------------------------------|
| Basic Standard: | EN 61000-4-2 |
| Discharge Impedance: | 330 ohm / 150 pF |
| Discharge Voltage: | Air Discharge: $\pm 2, \pm 4, \pm 8$ kV (Direct) Contact Discharge: $\pm 2, \pm 4, \pm 6$ kV (Direct/Indirect) |
| Number of Discharge: | Minimum 20 times at each test point |
| Discharge Mode: | Single Discharge |
| Discharge Period: | 1-second minimum |

8.2 Test Instruments

| Description Manufacturer | Model No. | Serial No. | Calibrated Date | Calibrated Until |
|-----------------------------------------|---------------------------------------|------------------------------|--------------------|---------------------|
| Electrostatic Analog Tester NoiseKen | ESS-B3011 | ESS12Z5082 | Nov. 18, 2021 | Nov. 17, 2022 |
| Electrostatic Analog Tester TESEQ | NSG 438 | 1614 | Aug. 10, 2021 | Aug. 09, 2022 |
| ESD Generator EM Test | Dito | V0701102114 | Nov. 18, 2021 | Nov. 17, 2022 |
| | Dito//DM-150/330//DM- 150/330-rfci | P1315117252 / P1317117852 | Jul. 09, 2021 | Jul. 08, 2022 |
| ESD Simulator KeyTek | MZ-15/EC | 0401299 | Oct. 07, 2021 | Oct. 06, 2022 |
| ESD Simulator Noiseken | ESS-B3011A | ESS1694113 | Aug. 21, 2021 | Aug. 20, 2022 |

- Notes:
1. The test was performed in HwaYa EFT ESD4.
 2. The calibration interval of the above test instruments is 12 months and the calibrations are traceable to NML/ROC and NIST/USA.
 3. Test Date: 2022/01/18.

8.3 Test Arrangement

- a. Electrostatic discharges were applied only to those points and surfaces of the EUT that are accessible to users during normal operation.
- b. The test was performed with at least ten single discharges on the pre-selected points in the most sensitive polarity.
- c. The time interval between two successive single discharges was at least 1 second.
- d. The ESD generator was held perpendicularly to the surface to which the discharge was applied and the return cable was at least 0.2 meters from the EUT.
- e. Contact discharges were applied to the non-insulating coating, with the pointed tip of the generator penetrating the coating and contacting the conducting substrate.
- f. Air discharges were applied with the round discharge tip of the discharge electrode approaching the EUT as fast as possible (without causing mechanical damage) to touch the EUT. After each discharge, the ESD generator was removed from the EUT and re-triggered for a new single discharge. The test was repeated until all discharges were complete.
- g. At least ten single discharges (in the most sensitive polarity) were applied to the **Horizontal Coupling Plane** at points on each side of the EUT. The ESD generator was positioned at a distance of 0.1 meters from the EUT with the discharge electrode touching the **HCP**.
- h. At least ten single discharges (in the most sensitive polarity) were applied to the center of one vertical edge of the **Vertical Coupling Plane** in sufficiently different positions that the four faces of the EUT were completely illuminated. The **VCP** (dimensions 0.5m x 0.5m) was placed vertically to and 0.1 meters from the EUT.

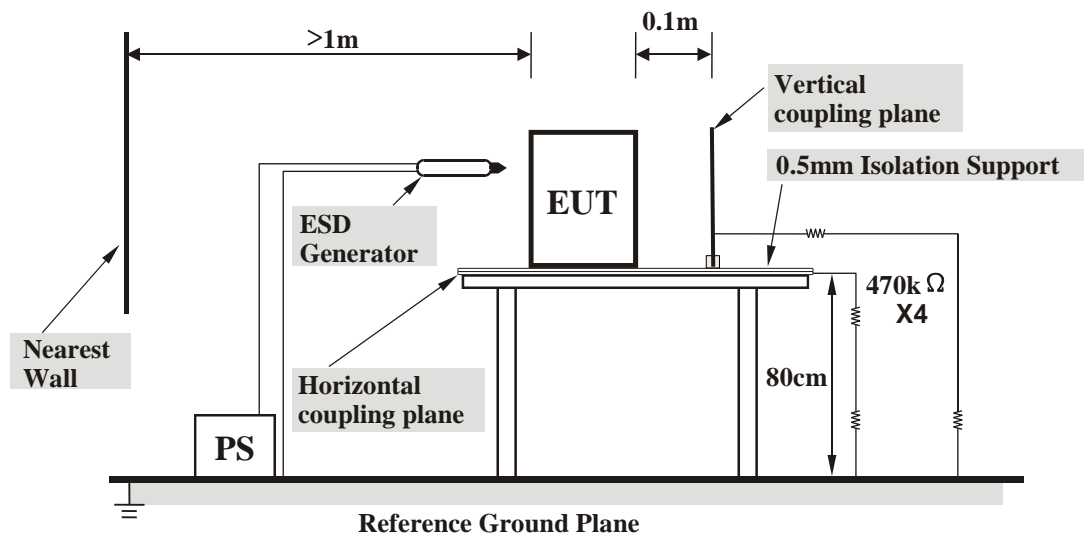

Table-top Equipment

The configuration consisted of a wooden table 0.8 meters high standing on the **Ground Reference Plane**. The **GRP** consisted of a sheet of aluminum at least 0.25mm thick, and 2.5 meters square connected to the protective grounding system. A **Horizontal Coupling Plane** (1.6m x 0.8m) was placed on the table and attached to the **GRP** by means of a cable with 940kΩ total impedance. The equipment under test, was installed in a representative system as described in section 7 of EN 61000-4-2, and its cables were placed on the **HCP** and isolated by an insulating support of 0.5mm thickness. A distance of 1-meter minimum was provided between the EUT and the walls of the laboratory and any other metallic structure.

8.4 Test Results

| | | | |
|-------------|----------|--------------------------|----------------------------|
| Input Power | 12Vdc | Environmental Conditions | 25 °C, 55 % RH 983 mbar |
| Tested by | Koma Kuo | Test Mode | A |

| Test Results of Direct Application | | | | | |
|------------------------------------|----------------|------------|-------------------|---------------|-----------------------|
| Discharge Level (kV) | Polarity (+/-) | Test Point | Contact Discharge | Air Discharge | Performance Criterion |
| 2,4,6 | +/- | 1-7 | Note | --- | A |
| 2,4,8 | +/- | 8-12 | --- | Note | A |

Description of test points of direct application: Please refer to following page for representative mark only.

| Test Results of Indirect Application | | | | | |
|--------------------------------------|----------------|------------|---------------------------|-------------------------|-----------------------|
| Discharge Level (kV) | Polarity (+/-) | Test Point | Horizontal Coupling Plane | Vertical Coupling Plane | Performance Criterion |
| 2,4,6 | +/- | Four Side | Note | Note | A |

Description of test points of indirect application:

1. Front side
2. Rear side
3. Right side
4. Left side

Note: The EUT is operated normal during the test.

DESCRIPTION OF TEST POINT

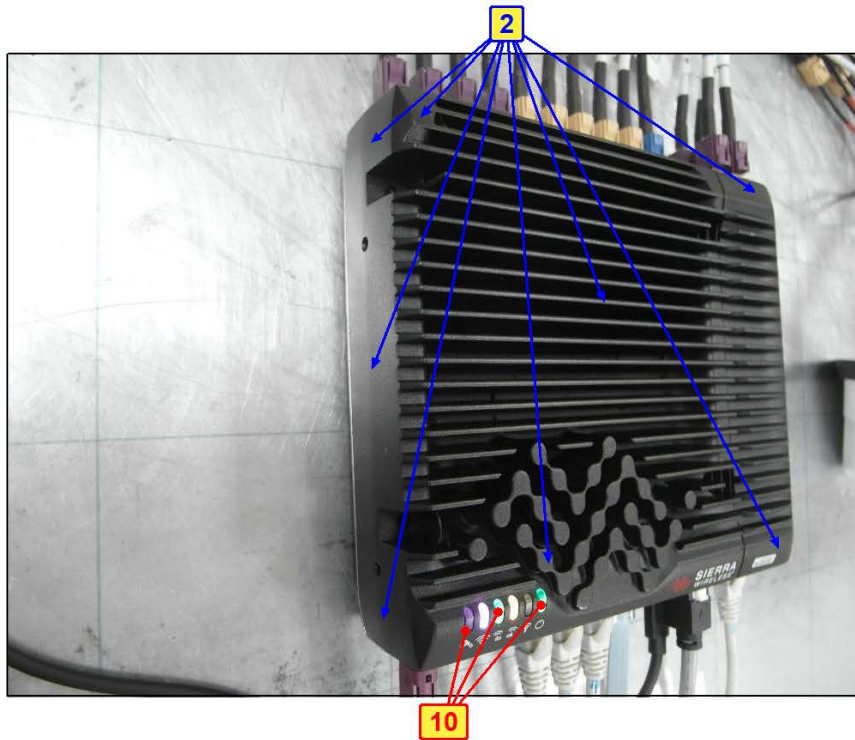
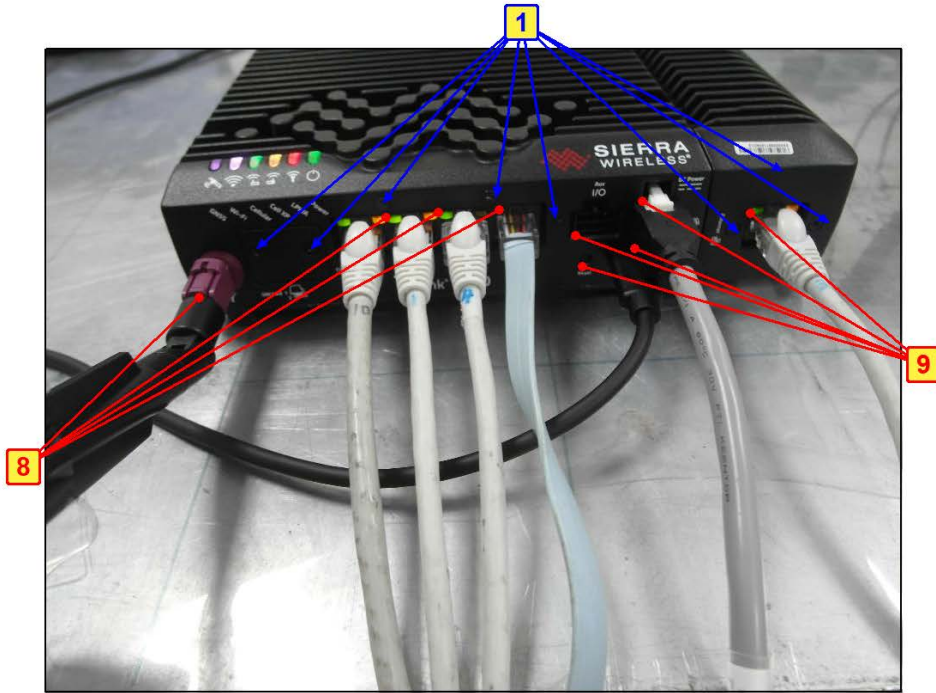

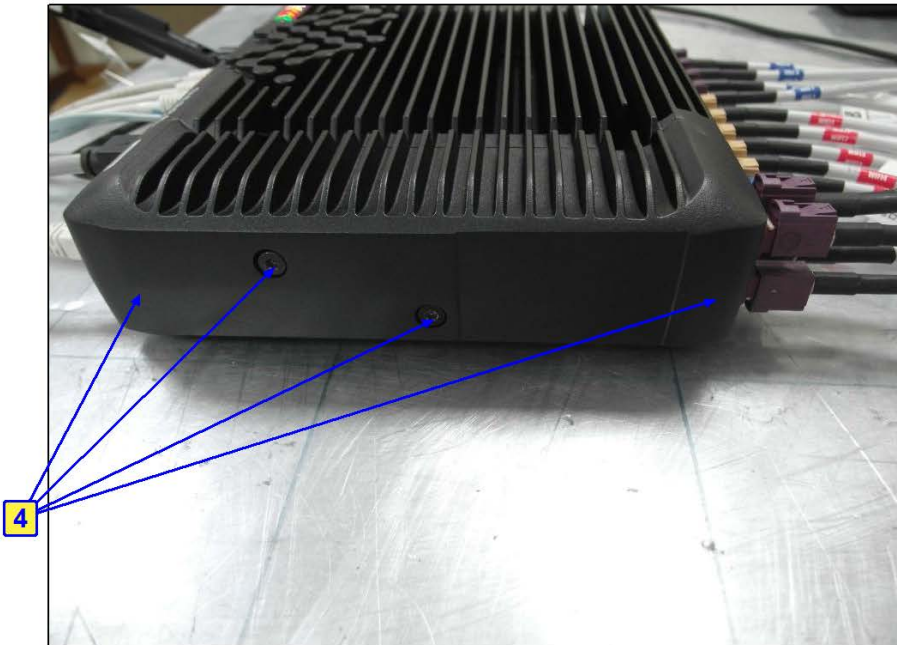
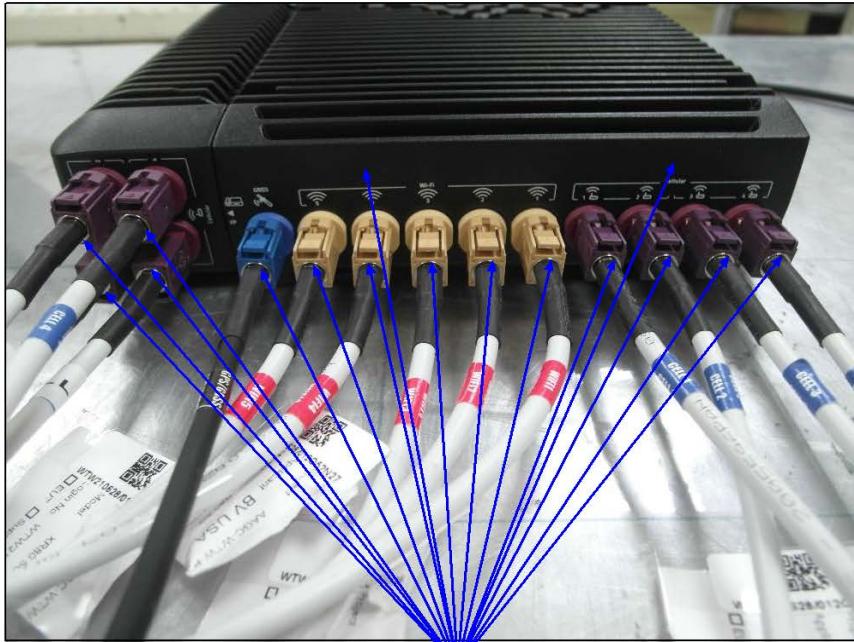

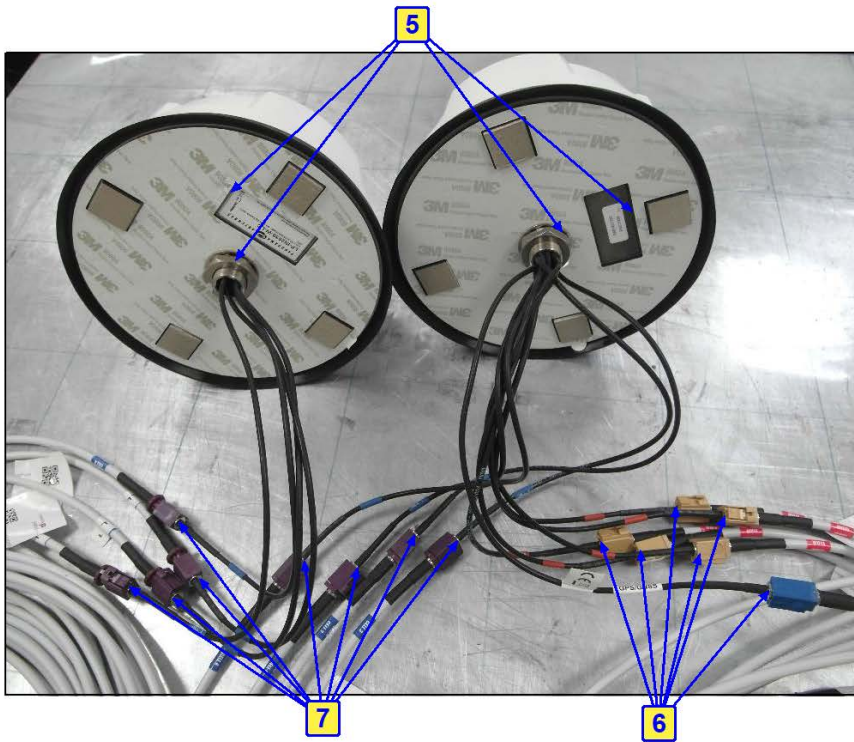

| | | | |
|-------------|----------|--------------------------|----------------------------|
| Input Power | 24Vdc | Environmental Conditions | 25 °C, 55 % RH 983 mbar |
| Tested by | Koma Kuo | Test Mode | B |

| Test Results of Direct Application | | | | | |
|------------------------------------|----------------|------------|-------------------|---------------|-----------------------|
| Discharge Level (kV) | Polarity (+/-) | Test Point | Contact Discharge | Air Discharge | Performance Criterion |
| 2,4,6 | +/- | 1-7 | Note | --- | A |
| 2,4,8 | +/- | 8-12 | --- | Note | A |

Description of test points of direct application: Please refer to following page for representative mark only.

| Test Results of Indirect Application | | | | | |
|--------------------------------------|----------------|------------|---------------------------|-------------------------|-----------------------|
| Discharge Level (kV) | Polarity (+/-) | Test Point | Horizontal Coupling Plane | Vertical Coupling Plane | Performance Criterion |
| 2,4,6 | +/- | Four Side | Note | Note | A |

Description of test points of indirect application:

1. Front side 2. Rear side 3. Right side 4. Left side

Note: The EUT is operated normal during the test.

DESCRIPTION OF TEST POINT

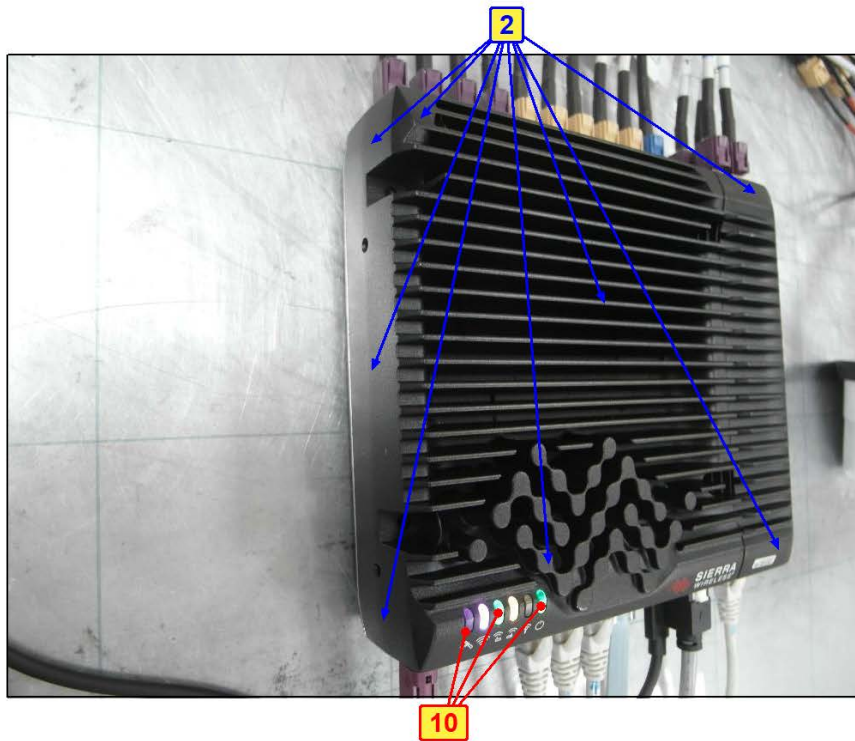
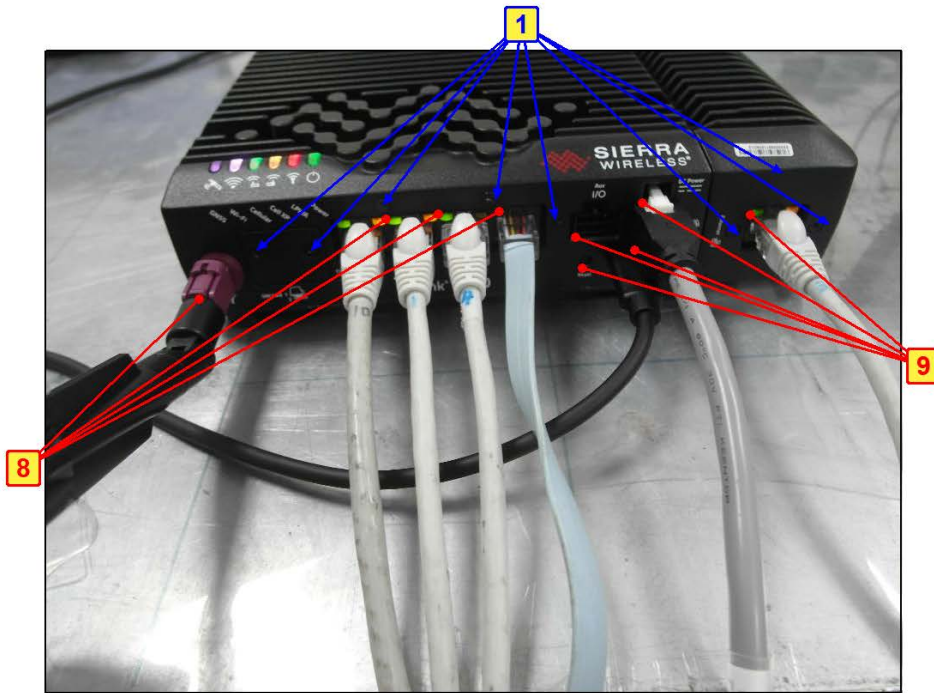

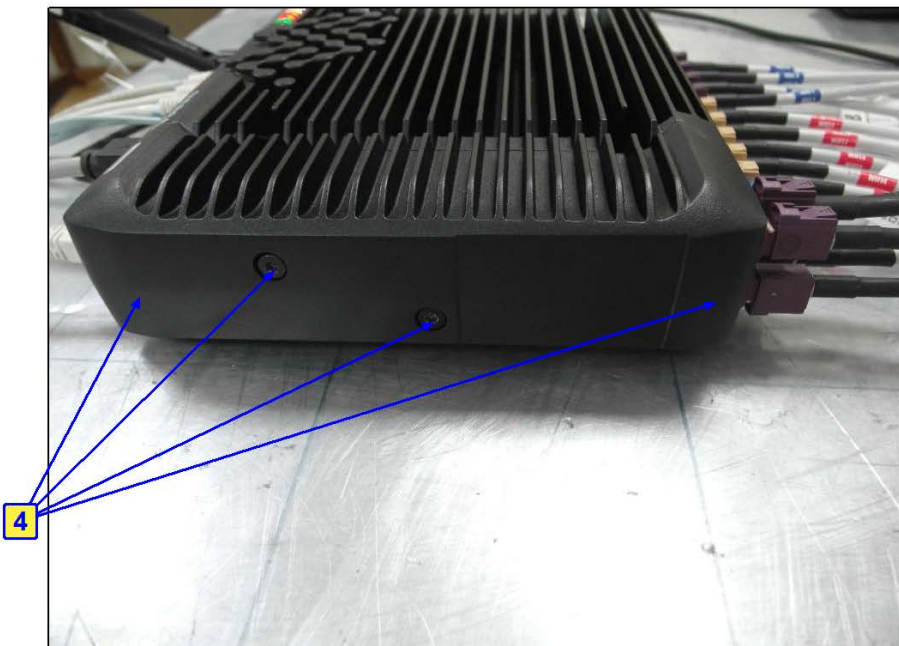
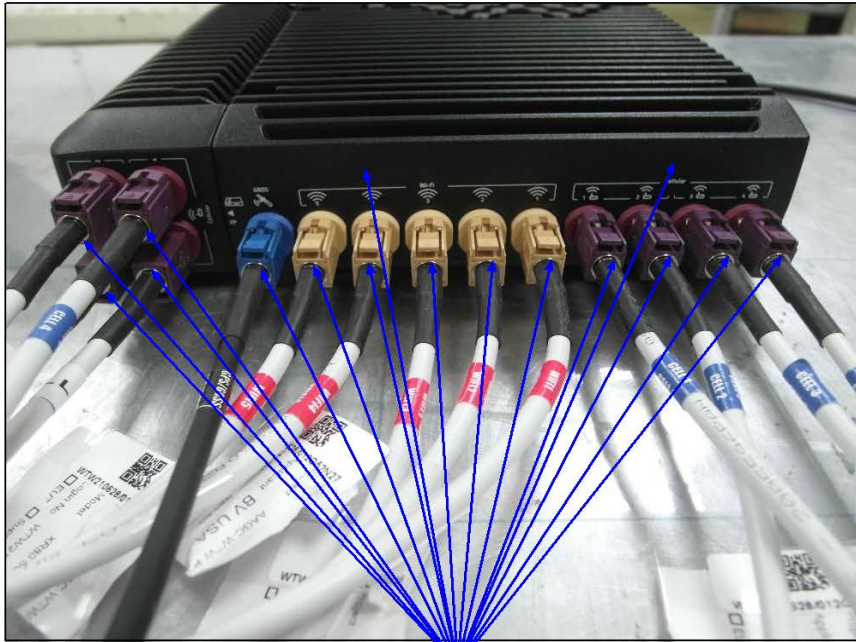

| | | | |
|-------------|----------|--------------------------|----------------------------|
| Input Power | 36Vdc | Environmental Conditions | 25 °C, 55 % RH 983 mbar |
| Tested by | Koma Kuo | Test Mode | C |

| Test Results of Direct Application | | | | | |
|------------------------------------|----------------|------------|-------------------|---------------|-----------------------|
| Discharge Level (kV) | Polarity (+/-) | Test Point | Contact Discharge | Air Discharge | Performance Criterion |
| 2,4,6 | +/- | 1-7 | Note | --- | A |
| 2,4,8 | +/- | 8-12 | --- | Note | A |

Description of test points of direct application: Please refer to following page for representative mark only.

| Test Results of Indirect Application | | | | | |
|--------------------------------------|----------------|------------|---------------------------|-------------------------|-----------------------|
| Discharge Level (kV) | Polarity (+/-) | Test Point | Horizontal Coupling Plane | Vertical Coupling Plane | Performance Criterion |
| 2,4,6 | +/- | Four Side | Note | Note | A |

Description of test points of indirect application:

1. Front side 2. Rear side 3. Right side 4. Left side

Note: The EUT is operated normal during the test.

DESCRIPTION OF TEST POINT

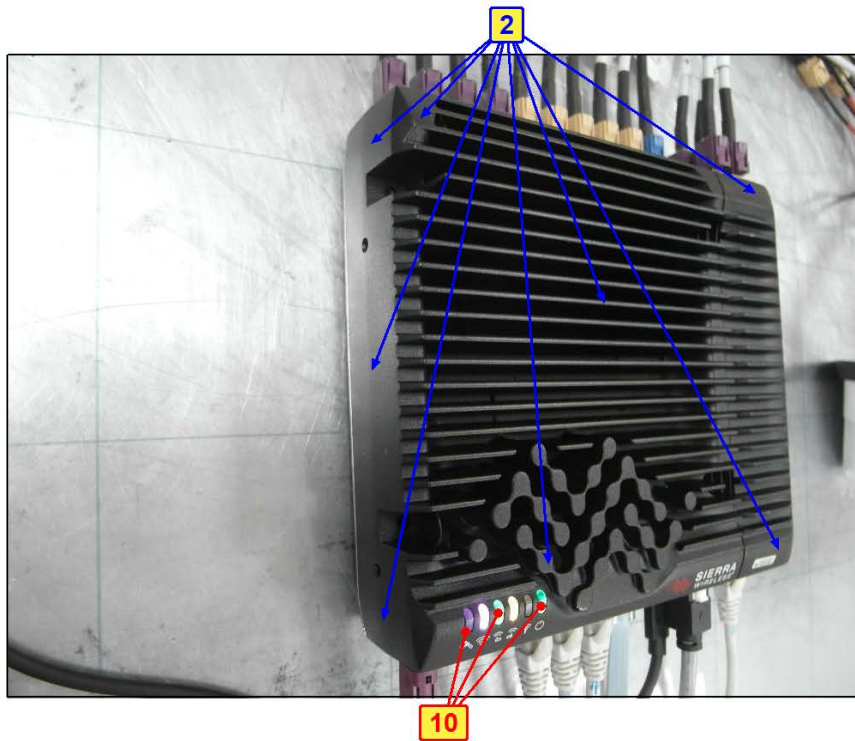
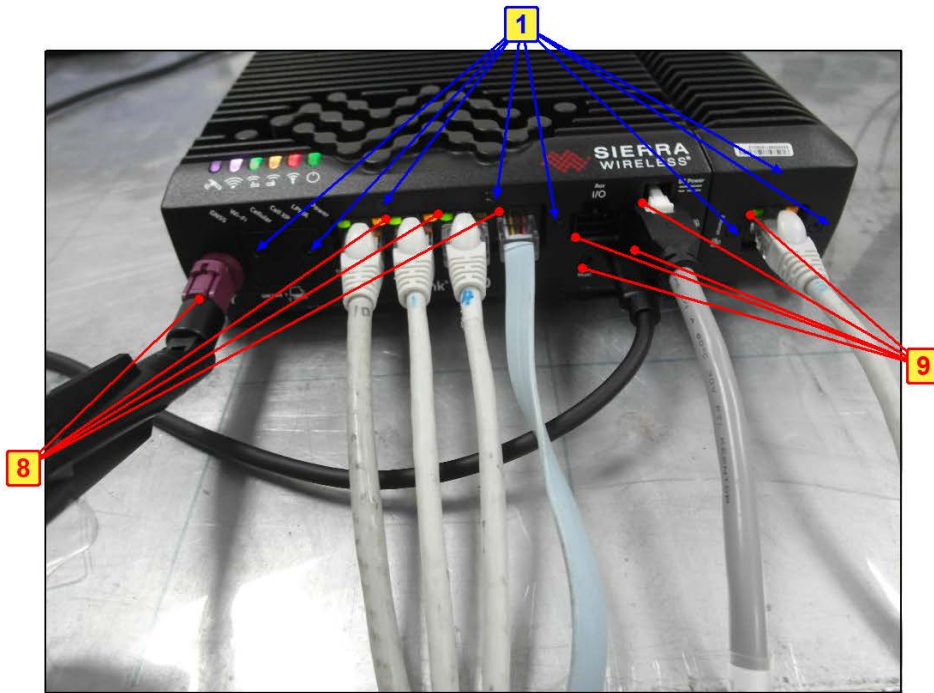

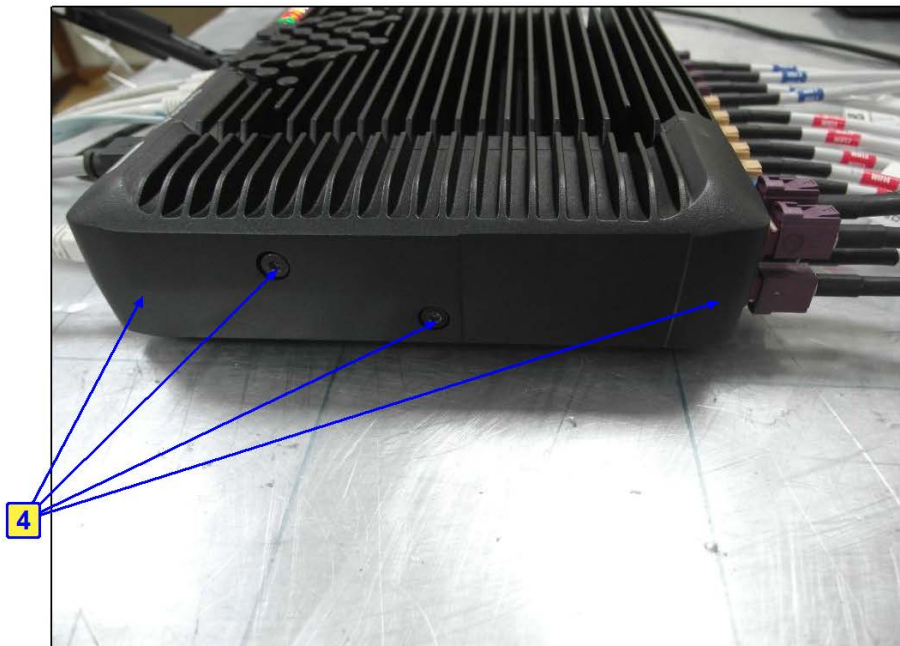
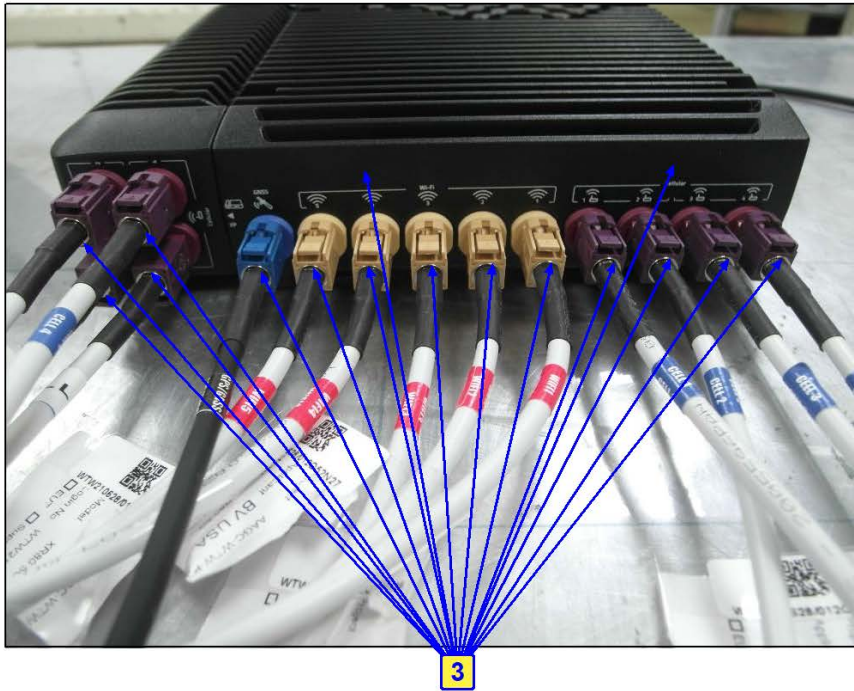

| | | | |
|-------------|----------|--------------------------|----------------------------|
| Input Power | 12Vdc | Environmental Conditions | 25 °C, 55 % RH 983 mbar |
| Tested by | Koma Kuo | Test Mode | D |

| Test Results of Direct Application | | | | | |
|------------------------------------|----------------|------------|-------------------|---------------|-----------------------|
| Discharge Level (kV) | Polarity (+/-) | Test Point | Contact Discharge | Air Discharge | Performance Criterion |
| 2,4,6 | +/- | 1-7 | Note | --- | A |
| 2,4,8 | +/- | 8-12 | --- | Note | A |

Description of test points of direct application: Please refer to following page for representative mark only.

| Test Results of Indirect Application | | | | | |
|--------------------------------------|----------------|------------|---------------------------|-------------------------|-----------------------|
| Discharge Level (kV) | Polarity (+/-) | Test Point | Horizontal Coupling Plane | Vertical Coupling Plane | Performance Criterion |
| 2,4,6 | +/- | Four Side | Note | Note | A |

Description of test points of indirect application:

1. Front side 2. Rear side 3. Right side 4. Left side

Note: The EUT is operated normal during the test.

DESCRIPTION OF TEST POINT

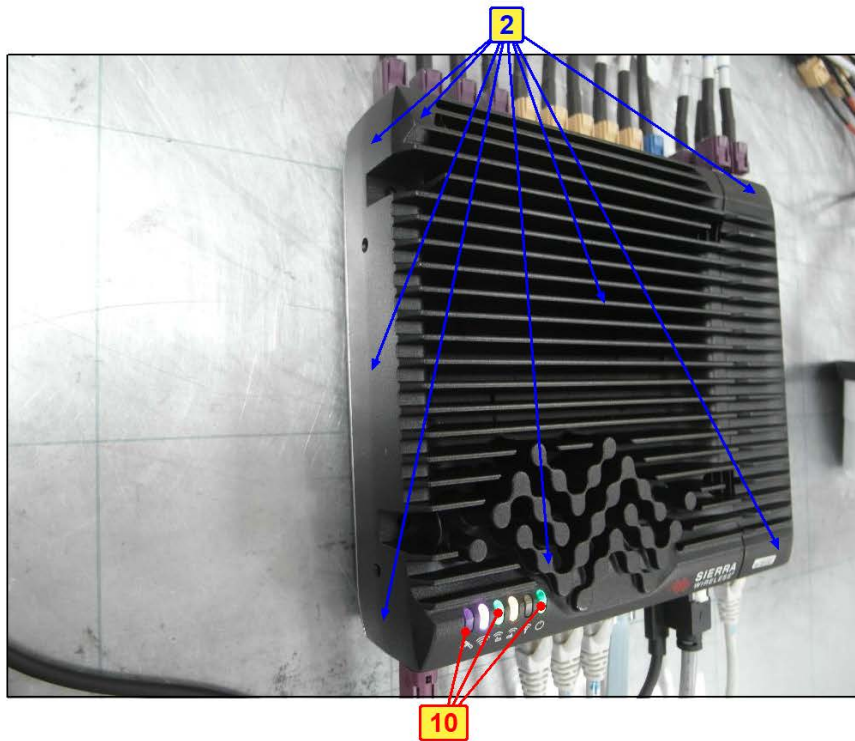
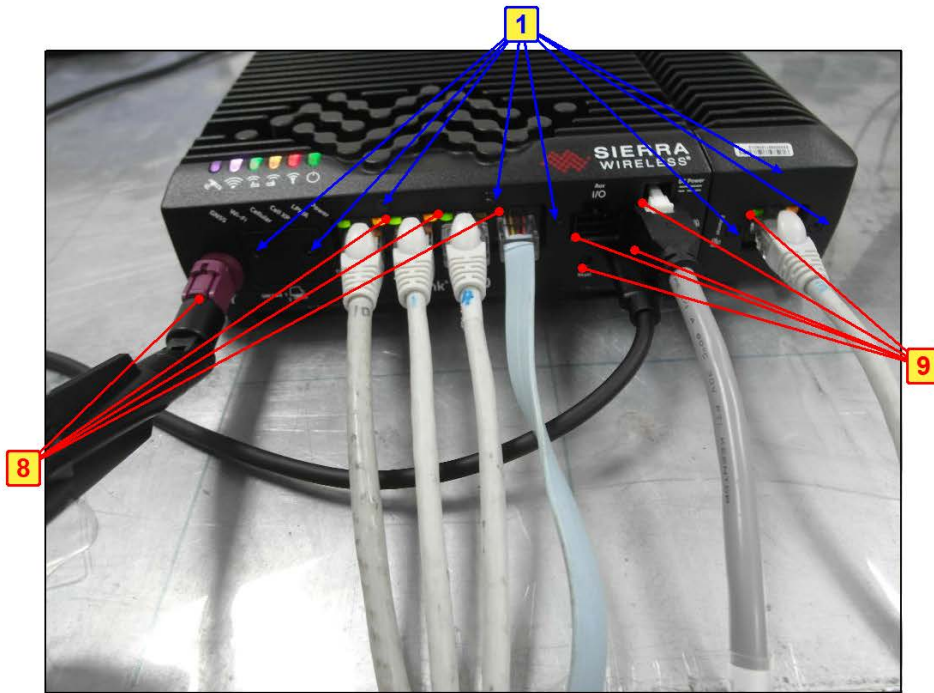

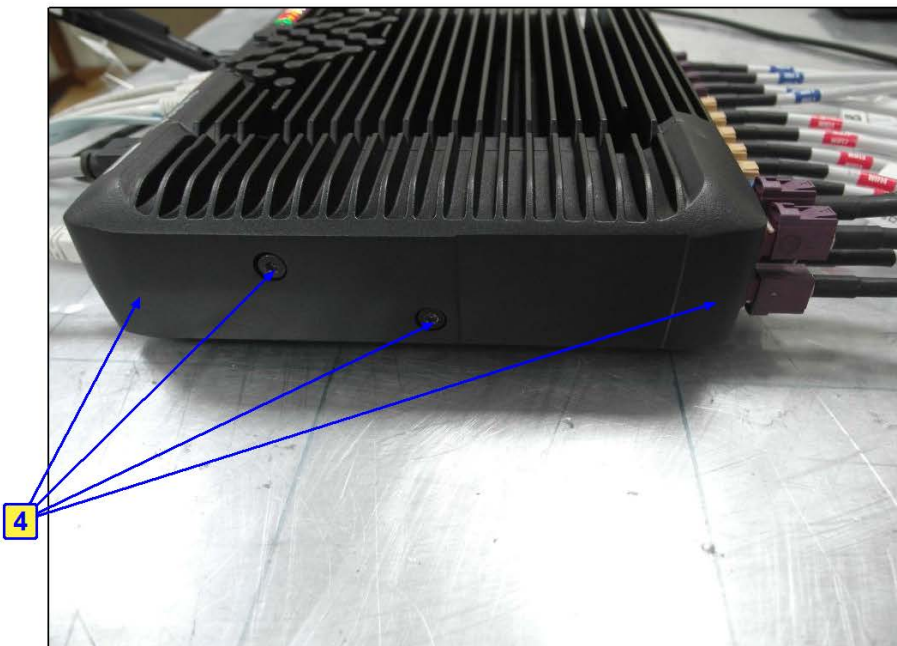
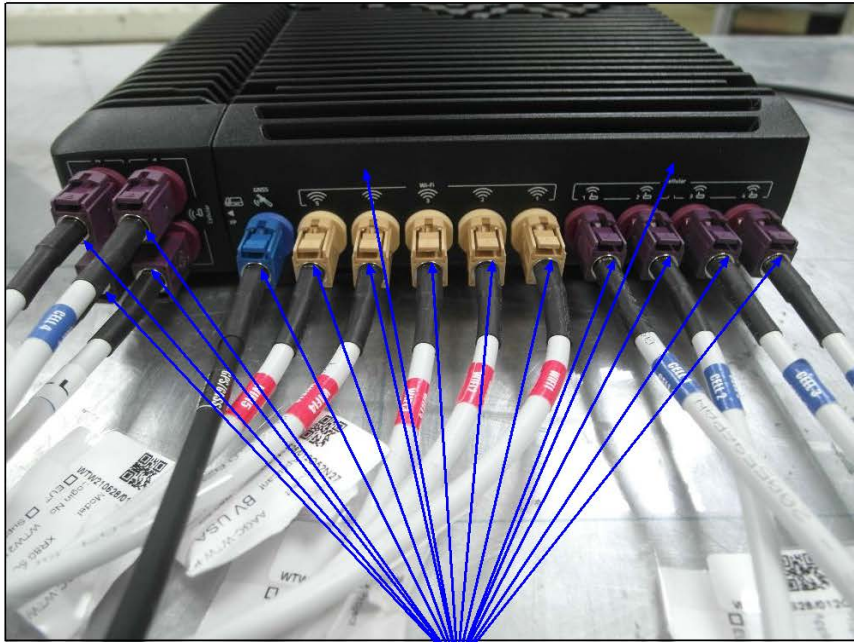

9 Radiated, Radio-frequency, Electromagnetic Field Immunity Test (RS)

9.1 Test Specification

| | |
|----------------------------------|------------------------------------|
| Basic Standard: | EN 61000-4-3 |
| | 80-800 MHz, 20V/m ¹ |
| Frequency Range, Field Strength: | 800-1000 MHz, 20V/m |
| | 1400-2000 MHz, 10V/m |
| | 2000-2700 MHz, 5V/m |
| | 5100-6000 MHz, 3V/m |
| Modulation: | 1kHz Sine Wave, 80%, AM Modulation |
| Frequency Step: | 1 % of preceding frequency value |
| Polarity of Antenna: | Horizontal and Vertical |
| Antenna Height: | 1.55m |
| Dwell Time: | 3 seconds |

Note 1: This limit applies to equipment mounted in the passenger compartments, drivers cab or external to the rolling stock (roof, underframe). For equipment mounted in all other areas a severity level of 10 V/m may be used.

9.2 Test Instruments

| Description & Manufacturer | Model No. | Serial No. | Cal. Date | Cal. Due |
|--------------------------------|-------------------------|------------|---------------|---------------|
| BONN Power Amp | BLMA 1060-100/50D | 118694 | NA | NA |
| BBA Power Amp | B250C125 | 101011 | NA | NA |
| Power Sensor | NRP-Z91 | 101572 | May 21, 2021 | May 20, 2022 |
| Power Sensor | NRP-Z91 | 101573 | May 21, 2021 | May 20, 2022 |
| Signal Generator | SMB100A | 105801 | Dec. 06, 2021 | Dec. 05, 2022 |
| R&S Software | EMC32 Version 8.52.0 | NA | NA | NA |
| Stacked Log-Per Antenna | STLP9149 | 9149-141 | NA | NA |
| High GAIN LOG-Periodic Antenna | HL046E | 100114 | NA | NA |

- Note:
1. The test was performed in HwaYa RS Room 2.
 2. The calibration interval of the above test instruments is 12 months and the calibrations are traceable to NML/ROC and NIST/USA.
 3. The transmit antenna was located at a distance of 1.5 meters / 3 meters from the EUT.
 4. Test Date: 2022/01/23.

9.3 Test Arrangement

The test procedure was in accordance with EN 61000-4-3.

- a. The testing was performed in a modified semi-anechoic chamber.
- b. The frequency ranges and field strength levels are 80-800 MHz, 20V/m, 800-1000 MHz, 20V/m, 1000-2200 MHz, 10V/m, 2200-2700 MHz, 5V/m and 5100-6000 MHz, 3V/m with the signal 80% amplitude modulated with a 1kHz sine wave.
- c. The test was performed with the EUT exposed to both vertically and horizontally polarized fields on each of the four sides.
- d. For 80 MHz to 1000 MHz, UFA size is in 0.5m*0.5m grid steps.

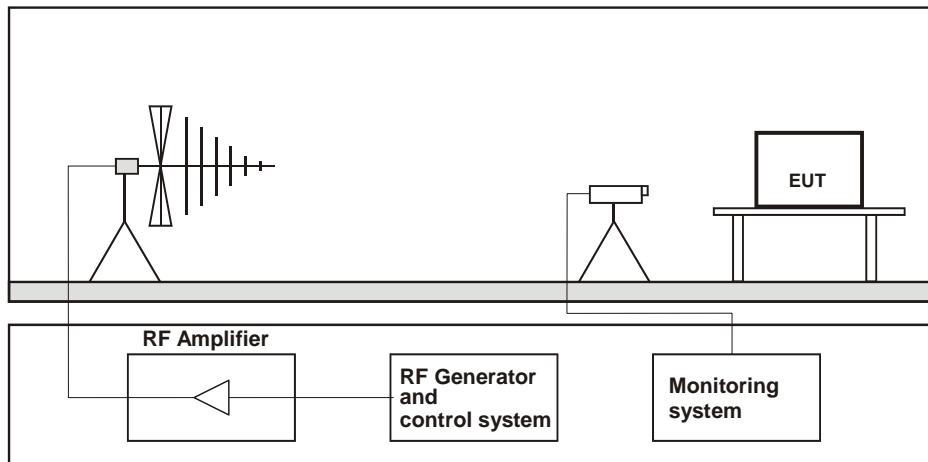

Table-top Equipment

The EUT installed in a representative system as described in section 7 of EN 61000-4-3 was placed on a non-conductive table 0.8 meters in height. The system under test was connected to the power and signal wire according to relevant installation instructions.

9.4 Test Results

| | | | |
|-------------|----------|--------------------------|---------------|
| Input Power | 12Vdc | Environmental Conditions | 23 °C, 58% RH |
| Tested by | Koma Kuo | Test Mode | A |

| Frequency (MHz) | Polarity | Azimuth(°) | Applied Field Strength | | Observation | Performance Criteria |
|-----------------|----------|-----------------|------------------------|---------------|-------------|----------------------|
| | | | (V/m) | Modulation | | |
| 80 - 1000 | V&H | 0, 90, 180, 270 | 20 | 80% AM (1kHz) | Note | A |
| 1400 - 2000 | V&H | 0, 90, 180, 270 | 10 | 80% AM (1kHz) | Note | A |
| 2000 – 2700 | V&H | 0, 90, 180, 270 | 5 | 80% AM (1kHz) | Note | A |
| 5100 - 6000 | V&H | 0, 90, 180, 270 | 3 | 80% AM (1kHz) | Note | A |

Note: The EUT is operated normal during the test.

| | | | |
|-------------|----------|--------------------------|---------------|
| Input Power | 24Vdc | Environmental Conditions | 23 °C, 58% RH |
| Tested by | Koma Kuo | Test Mode | B |

| Frequency (MHz) | Polarity | Azimuth(°) | Applied Field Strength | | Observation | Performance Criteria |
|-----------------|----------|-----------------|------------------------|---------------|-------------|----------------------|
| | | | (V/m) | Modulation | | |
| 80 - 1000 | V&H | 0, 90, 180, 270 | 20 | 80% AM (1kHz) | Note | A |
| 1400 - 2000 | V&H | 0, 90, 180, 270 | 10 | 80% AM (1kHz) | Note | A |
| 2000 – 2700 | V&H | 0, 90, 180, 270 | 5 | 80% AM (1kHz) | Note | A |
| 5100 - 6000 | V&H | 0, 90, 180, 270 | 3 | 80% AM (1kHz) | Note | A |

Note: The EUT is operated normal during the test.

| | | | |
|-------------|----------|--------------------------|---------------|
| Input Power | 36Vdc | Environmental Conditions | 23 °C, 58% RH |
| Tested by | Koma Kuo | Test Mode | C |

| Frequency (MHz) | Polarity | Azimuth(°) | Applied Field Strength | | Observation | Performance Criteria |
|-----------------|----------|-----------------|------------------------|---------------|-------------|----------------------|
| | | | (V/m) | Modulation | | |
| 80 - 1000 | V&H | 0, 90, 180, 270 | 20 | 80% AM (1kHz) | Note | A |
| 1400 - 2000 | V&H | 0, 90, 180, 270 | 10 | 80% AM (1kHz) | Note | A |
| 2000 – 2700 | V&H | 0, 90, 180, 270 | 5 | 80% AM (1kHz) | Note | A |
| 5100 - 6000 | V&H | 0, 90, 180, 270 | 3 | 80% AM (1kHz) | Note | A |

Note: The EUT is operated normal during the test.

| | | | |
|-------------|----------|--------------------------|---------------|
| Input Power | 12Vdc | Environmental Conditions | 23 °C, 58% RH |
| Tested by | Koma Kuo | Test Mode | D |

| Frequency (MHz) | Polarity | Azimuth(°) | Applied Field Strength | | Observation | Performance Criteria |
|-----------------|----------|-----------------|------------------------|---------------|-------------|----------------------|
| | | | (V/m) | Modulation | | |
| 80 - 1000 | V&H | 0, 90, 180, 270 | 20 | 80% AM (1kHz) | Note | A |
| 1400 - 2000 | V&H | 0, 90, 180, 270 | 10 | 80% AM (1kHz) | Note | A |
| 2000 – 2700 | V&H | 0, 90, 180, 270 | 5 | 80% AM (1kHz) | Note | A |
| 5100 - 6000 | V&H | 0, 90, 180, 270 | 3 | 80% AM (1kHz) | Note | A |

Note: The EUT is operated normal during the test.

10 Electrical Fast Transient/Burst Immunity Test (EFT)

10.1 Test Specification

| | |
|-------------------------------|-------------------------------------------------------------------------------------------------------------------------------------------------------------------------------------------------------------------------------------------------------------------------|
| Basic Standard: | EN 61000-4-4 |
| Test Voltage: | Signal & communication, process measurement & control ports: $\pm 2\text{kV}$, Capacitive clamp Battery referenced ports (except at the output of energy sources), Auxiliary a.c. power input ports (rated voltage $\leq 400\text{ Vrms}$): $\pm 2\text{kV}$ |
| Impulse Repetition Frequency: | 5kHz |
| Impulse Wave Shape: | 5/50 (T_r/T_h) ns |
| Burst Duration: | 15 ms |
| Burst Period: | 300 ms |
| Test Duration: | 1 min. |

10.2 Test Instruments

| Description & Manufacturer | Model No. | Serial No. | Cal. Date | Cal. Due |
|-------------------------------------------------------|---------------|------------|---------------|---------------|
| EFT Generator TESEQ | NSG 3040 | 2251 | Mar. 09, 2021 | Mar. 08, 2022 |
| Capacitive Coupling clamp EMC-Partner | CN-EFT1000 | 364 | Mar. 09, 2021 | Mar. 08, 2022 |
| EFT Adapter WONPRO | WA | EF1Ada-001 | NA | NA |
| Three-phase coupling / decoupling network TESEQ | CDN 3043 | 5007 | Mar. 09, 2021 | Mar. 08, 2022 |
| Surge&EFT Generators TESEQ | NSG 3060 | 1572 | Apr. 24, 2021 | Apr. 23, 2022 |
| Coupling and Decoupling Network EMC PARTNER | CDN2000 06 32 | 093 | Jun. 30, 2021 | Jun. 29, 2022 |

- Note: 1. The test was performed in HwaYa EFT ESD4.
2. The calibration interval of the above test instruments is 12 months and the calibrations are traceable to NML/ROC and NIST/USA.
3. Test Date: 2022/03/02.

10.4 Test Results

| | | | |
|-------------|----------|--------------------------|----------------|
| Input Power | 12Vdc | Environmental Conditions | 25 °C, 55 % RH |
| Tested by | Koma Kuo | Test Mode | A |

| Input DC power port | | | | |
|---------------------|-------------|----------------|-------------|----------------------|
| Voltage (kV) | Test Point | Polarity (+/-) | Observation | Performance Criteria |
| 2 | DC(+) | +/- | Note | A |
| 2 | DC(-) | +/- | Note | A |
| 2 | DC(+)-DC(-) | +/- | Note | A |

| Wired network and signal/ control port | | | | |
|----------------------------------------|------------------|----------------|-------------|----------------------|
| Voltage (kV) | Test Point | Polarity (+/-) | Observation | Performance Criteria |
| 2 | LAN 1 | +/- | Note | A |
| 2 | LAN 2 | +/- | Note | A |
| 2 | LAN R | +/- | Note | A |
| 2 | ANT Left(Front) | +/- | Note | A |
| 2 | ANT Right(Front) | +/- | Note | A |
| 2 | ANT Left(Rear) | +/- | Note | A |
| 2 | ANT Right(Rear) | +/- | Note | A |

Note: The EUT function was correct during the test.

| | | | |
|-------------|----------|--------------------------|----------------|
| Input Power | 24Vdc | Environmental Conditions | 25 °C, 55 % RH |
| Tested by | Koma Kuo | Test Mode | B |

| Input DC power port | | | | |
|---------------------|----------------|----------------|-------------|----------------------|
| Voltage (kV) | Test Point | Polarity (+/-) | Observation | Performance Criteria |
| 2 | DC(+) | +/- | Note | A |
| 2 | DC(-) | +/- | Note | A |
| 2 | DC(+)-DC(-)-PE | +/- | Note | A |

Note: The EUT function was correct during the test.

| | | | |
|-------------|----------|--------------------------|----------------|
| Input Power | 36Vdc | Environmental Conditions | 25 °C, 55 % RH |
| Tested by | Koma Kuo | Test Mode | C |

| Input DC power port | | | | |
|---------------------|-------------|----------------|-------------|----------------------|
| Voltage (kV) | Test Point | Polarity (+/-) | Observation | Performance Criteria |
| 2 | DC(+) | +/- | Note | A |
| 2 | DC(-) | +/- | Note | A |
| 2 | DC(+)-DC(-) | +/- | Note | A |

Note: The EUT function was correct during the test.

| | | | |
|-------------|----------|--------------------------|----------------|
| Input Power | 12Vdc | Environmental Conditions | 25 °C, 55 % RH |
| Tested by | Koma Kuo | Test Mode | D |

| Input DC power port | | | | |
|---------------------|-------------|----------------|-------------|----------------------|
| Voltage (kV) | Test Point | Polarity (+/-) | Observation | Performance Criteria |
| 2 | DC(+) | +/- | Note | A |
| 2 | DC(-) | +/- | Note | A |
| 2 | DC(+)-DC(-) | +/- | Note | A |

Note: The EUT function was correct during the test.

11 Surge Immunity Test

11.1 Test Specification

| | |
|--------------------------|-----------------------------------------------------------------------------------------------------------------------------------------------------------------------------|
| Basic Standard: | EN/IEC 61000-4-5 |
| Wave-Shape: | Auxiliary a.c. power input ports (rated voltage ≤ 400 Vrms): 1.2/50 μ s Open Circuit Voltage 8/20 μ s Short Circuit Current |
| Test Voltage: | Line to line: ± 1 kV, Line to ground: ± 2 kV output impedance of 42 Ω (40 Ω and 2 Ω generator) and a coupling capacitance of 0,5 μ F |
| AC Phase Angle (degree): | 0°, 90°, 180°, 270° |
| Pulse Repetition Rate: | 1 time / 60 sec. |
| Number of Tests: | 5 positive and 5 negative at selected points |

* This test is only applicable only to ports, which according to the manufacturer's specification, may connect directly to outdoor cables.

** For ports where primary protection is intended, surges are applied at voltages up to 4 kV with the primary protectors fitted. Otherwise the 1 kV test level is applied without primary protection in place.

11.2 Test Instruments

| Description & Manufacturer | Model No. | Serial No. | Cal. Date | Cal. Due |
|-------------------------------------------------------------|--------------------------------------------------|------------------------|---------------|---------------|
| Universal Surge Coupling De-Coupling Network em test | CNV 508T5 | P1508149592 | Jun. 24, 2021 | Jun. 23, 2022 |
| Universal Surge Coupling De-Coupling Network TESEQ | CDN HSS-2 | 41008 | Jun. 24, 2021 | Jun. 23, 2022 |
| Modular Impulse Generator TESEQ | NSG 3060 / CDN 3061 | 1796 /1554 | Mar. 10, 2021 | Mar. 9, 2022 |
| Telecom surge module TESEQ | NSG 3060 | 1799 | Mar. 10, 2021 | Mar. 9, 2022 |
| Combo set for Dip/EFT/Surge TESEQ | NSG 3060/ CDN 3061/ VAR 3005-S16/ CDN 3425 | 1385/1355/857/176 3 | Jun. 23, 2021 | Jun. 22, 2022 |
| EMC Immunity Tester EMC PARTNER | TRANSIENT 2000 | 622 | Mar. 09, 2021 | Mar. 08, 2022 |
| Modular Impulse Generator EMC-Partner | MIG0603IN3 IEC-ANSI | 352 | Aug. 13, 2021 | Aug. 12, 2021 |
| Universal Surge Coupling De-Coupling Network EMC-PARTNER | CDN-UTP8 | 011 | Jun. 24, 2021 | Jun. 23, 2022 |
| Surge Adapter WONPRO | WA | SU1 Ada-001 | NA | NA |

- Notes: 1. The test was performed in HwaYa Surge Room 1.
2. The calibration interval of the above test instruments is 12 months and the calibrations are traceable to NML/ROC and NIST/USA.
3. Test Date: 2022/02/03.

11.3 Test Arrangement

a. Input AC/DC Power ports:

The surge is to be applied to the EUT power supply terminals via the capacitive coupling network. Decoupling networks are required in order to avoid possible adverse effects on equipment not under test that may be powered by the same lines, and to provide sufficient decoupling impedance to the surge wave. The power cord between the EUT and the coupling/decoupling networks shall be 2 meters in length (or shorter).

For double-insulated products without PE or external earth connections, the test shall be done in a similar way as for grounded products but without adding any additional external grounded connections. If there are no other possible connections to earth, line-to-ground tests may be omitted.

b. Signal and telecommunication ports,

- Unshielded unsymmetrical interconnection lines:

The surge is applied to the lines via the capacitive coupling. The coupling / decoupling networks shall not influence the specified functional conditions of the EUT. The interconnection line between the EUT and the coupling/decoupling networks shall be 2 meters in length.

- Unshielded symmetrical interconnections communication lines:

The surge is applied to the lines via gas arrestors coupling. Test levels below the ignition point of the coupling arrestor cannot be specified. The interconnection line between the EUT and the coupling/decoupling networks shall be 2 meters in length.

- High speed communications lines

Prior to the test, the correct operation of the port shall be verified; the external connection shall then be removed and the surge applied directly to the port's terminals with no coupling /decoupling network. After the surge, the correct operation of the port shall again be verified.

- **Shielded lines:**

- Direct application,

The EUT is isolated from ground and the surge is applied to its metallic enclosure; the termination (or auxiliary equipment) at the port(s) under test is grounded. This test applies to equipment with single or multiple shielded cables.

Rules for application of the surge to shielded lines:

- a) Shields grounded at both ends

- The surge injection on the shield.

- b) Shields grounded at one end

- If in the installation the shield is connected only at the auxiliary equipment, test shall be done in that configuration but with the generator still connected to the EUT side. If cable lengths allow, the cables shall be on insulated supports 0,1 m above the ground plane or cable tray.

For products which do not have metallic enclosures, the surge is applied directly to the shielded cable.

- Alternative coupling method for testing single cables in a multi-shield configuration,

Surges are applied in close proximity to the interconnection cable under test by a wire. The length of the cable between the port(s) under test and the device attached to the other end of the cable shall be the lesser of: the maximum length permitted by the EUT's specification, or 20 m. Where the length exceeds 1 m, excess lengths of cables shall be bundled at the approximate centre of the cables with the bundles 30 cm to 40 cm in length.

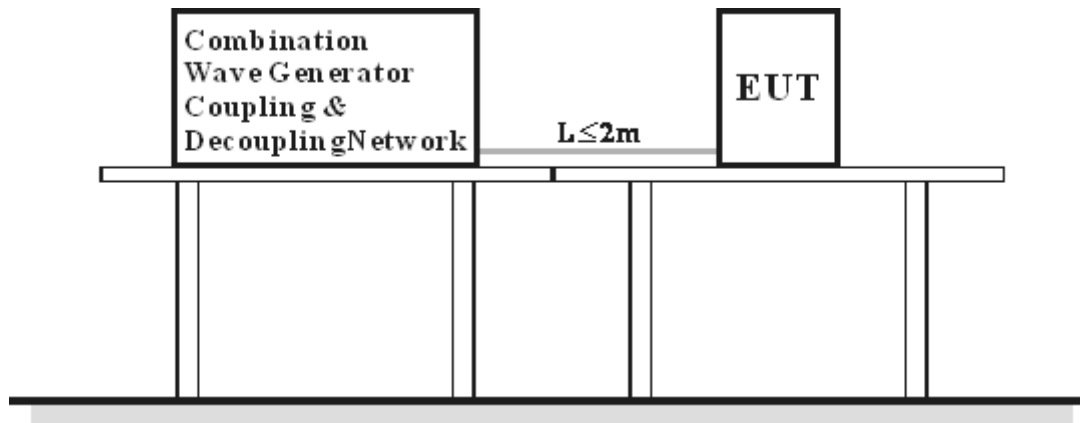

11.4 Test Results

| | | | |
|-------------|----------|--------------------------|----------------|
| Input Power | 12Vdc | Environmental Conditions | 25 °C, 58 % RH |
| Tested by | Koma Kuo | Test Mode | A |

| Input DC power port | | | | |
|---------------------|---------------|----------------|-------------|----------------------|
| Voltage (kV) | Test Point | Polarity (+/-) | Observation | Performance Criteria |
| 1 | DC(+) - DC(-) | + | Note2 | B |
| 1 | DC(+) - DC(-) | - | Note1 | A |
| 2 | DC(+) - PE | + | Note2 | B |
| 2 | DC(+) - PE | - | Note1 | A |
| 2 | DC(-) - PE | +/- | Note2 | B |

- Note: 1. The EUT is operated normal during the test.
 2. The EUT had shut down during the test, but could self-recover to the initial operation after the test.

| | | | |
|-------------|----------|--------------------------|----------------|
| Input Power | 24Vdc | Environmental Conditions | 25 °C, 58 % RH |
| Tested by | Koma Kuo | Test Mode | B |

| Input DC power port | | | | |
|---------------------|---------------|----------------|-------------|----------------------|
| Voltage (kV) | Test Point | Polarity (+/-) | Observation | Performance Criteria |
| 1 | DC(+) - DC(-) | + | Note2 | B |
| 1 | DC(+) - DC(-) | - | Note1 | A |
| 2 | DC(+) - PE | + | Note2 | B |
| 2 | DC(+) - PE | - | Note1 | A |
| 2 | DC(-) - PE | + | Note2 | B |
| 2 | DC(-) - PE | - | Note1 | A |

- Note: 1. The EUT is operated normal during the test.
 2. The EUT had shut down during the test, but could self-recover to the initial operation after the test.

| | | | |
|-------------|----------|--------------------------|----------------|
| Input Power | 36Vdc | Environmental Conditions | 25 °C, 58 % RH |
| Tested by | Koma Kuo | Test Mode | C |

| Input DC power port | | | | |
|---------------------|---------------|----------------|-------------|----------------------|
| Voltage (kV) | Test Point | Polarity (+/-) | Observation | Performance Criteria |
| 1 | DC(+) - DC(-) | + | Note2 | B |
| 1 | DC(+) - DC(-) | - | Note1 | A |
| 2 | DC(+) - PE | + | Note2 | B |
| 2 | DC(+) - PE | - | Note1 | A |
| 2 | DC(-) - PE | + | Note2 | B |
| 2 | DC(-) - PE | - | Note1 | A |

Note: 1. The EUT is operated normal during the test.
 2. The EUT had shut down during the test, but could self-recover to the initial operation after the test.

| | | | |
|-------------|----------|--------------------------|----------------|
| Input Power | 12Vdc | Environmental Conditions | 25 °C, 58 % RH |
| Tested by | Koma Kuo | Test Mode | D |

| Input DC power port | | | | |
|---------------------|---------------|----------------|-------------|----------------------|
| Voltage (kV) | Test Point | Polarity (+/-) | Observation | Performance Criteria |
| 1 | DC(+) - DC(-) | + | Note2 | B |
| 1 | DC(+) - DC(-) | - | Note1 | A |
| 2 | DC(+) - PE | + | Note2 | B |
| 2 | DC(+) - PE | - | Note1 | A |
| 2 | DC(-) - PE | +/- | Note2 | B |

Note: 1. The EUT is operated normal during the test.
 2. The EUT had shut down during the test, but could self-recover to the initial operation after the test.

12 Immunity to Conducted Disturbances Induced by RF Fields (CS)

12.1 Test Specification

| | |
|------------------|--------------------------------------------------------------------------------------------------------------------------------------------------------------------------------------------------------------|
| Basic Standard: | EN 61000-4-6 |
| Frequency Range: | 0.15 MHz - 80 MHz |
| Voltage Level: | Battery referenced ports (except at the output of energy sources), Auxiliary a.c. power input ports (rated voltage \leq 400 Vrms), Signal & communication, process measurement & control ports: 10 V |
| Modulation: | 1kHz Sine Wave, 80%, AM Modulation |
| Frequency Step: | 1 % of preceding frequency value |
| Dwell Time | 3 seconds |

12.2 Test Instruments

| Description & Manufacturer | Model No. | Serial No. | Cal. Date | Cal. Due |
|--------------------------------------------------------|-----------------|------------|---------------|---------------|
| FCC POWER LINE COUPLING DECOUPLING NETWORK | FCC-801-M1-25A | 03030 | Mar. 03, 2021 | Mar. 02, 2022 |
| FCC POWER LINE COUPLING DECOUPLING NETWORK | FCC-801-M2-25A | 03049 | Mar. 04, 2021 | Mar. 03, 2022 |
| FCC POWER LINE COUPLING DECOUPLING NETWORK | FCC-801-M2-25A | 03050 | Mar. 03, 2021 | Mar. 02, 2022 |
| FCC POWER LINE COUPLING DECOUPLING NETWORK | FCC-801-M3-25A | 03056 | Mar. 03, 2021 | Mar. 02, 2022 |
| FCC SIGNAL LINE POWER LINE COUPLING DECOUPLING NETWORK | CDN T200A | 38295 | Mar. 03, 2021 | Mar. 02, 2022 |
| FCC SIGNAL LINE POWER LINE COUPLING DECOUPLING NETWORK | CDN T200A | 41298 | Mar. 03, 2021 | Mar. 02, 2022 |
| FCC SIGNAL LINE POWER LINE COUPLING DECOUPLING NETWORK | FCC-801-T4 | 03031 | Mar. 03, 2021 | Mar. 02, 2022 |
| Coupling Decoupling Network TESEQ | CDN S150 | 34832 | Mar. 04, 2021 | Mar. 03, 2022 |
| Coupling Decoupling Network TESEQ | CDN USB3.0 | 37041 | Mar. 04, 2021 | Mar. 03, 2022 |
| Coupling Decoupling Network TESEQ | CDN HDMI | 36670 | Mar. 04, 2021 | Mar. 03, 2022 |
| Coupling Decoupling Network TESEQ | CDN T400A | 28577 | Mar. 03, 2021 | Mar. 02, 2022 |
| FCC SIGNAL LINE POWER LINE COUPLING DECOUPLING NETWORK | F-090407-1004-1 | 100923 | Mar. 03, 2021 | Mar. 02, 2022 |
| Coupling Decoupling Network TESEQ | CDN T8-10 | 43230 | Mar. 03, 2021 | Mar. 02, 2022 |
| Coupling Decoupling Network TESEQ | CDN T8-10 | 43229 | Mar. 03, 2021 | Mar. 02, 2022 |
| Coupling Decoupling Network TESEQ | CDN S751S | 35791 | Mar. 04, 2021 | Mar. 03, 2022 |
| Coupling Decoupling Network TESEQ | CDN ST08A | 56526 | Feb. 26, 2021 | Feb. 25, 2022 |
| EMI Injection Clamp | F203I-23MM | 434 | Apr. 09, 2021 | Apr. 08, 2022 |
| Amplifier Research Power Amplifier | 75A250AM2 | 307804 | NA | NA |
| Signal Generator ROHDE & SCHWARZ | SML03 | 101801 | Jan. 11, 2022 | Jan. 10, 2023 |
| POWER METER BOONTON | 4232A | 107402 | Jul. 12, 2021 | Jul. 11, 2022 |
| POWER SENSOR BOONTON | 51011-EMC | 33105 | Jul. 12, 2021 | Jul. 11, 2022 |
| POWER SENSOR BOONTON | 51011-EMC | 33107 | Jul. 12, 2021 | Jul. 11, 2022 |
| Software | ADT_CS_V37 | NA | NA | NA |
| 6dB Attenuator | 6NFNF150ATT | NA | NA | NA |

- Note:
1. The test was performed in HwaYa CS Room 1.
 2. The calibration interval of the above test instruments is 12 months and the calibrations are traceable to NML/ROC and NIST/USA.
 3. Test Date: 2022/02/01.

12.3 Test Arrangement

- The EUT shall be tested within its intended operating and climatic conditions.
- An artificial hand was placed on the hand-held accessory and connected to the ground reference plane.
- One of the CDNs not used for injection was terminated with 50 ohm, providing only one return path. All other CDNs were coupled as decoupling networks.
- The frequency range is swept from 150 kHz to 80 MHz, using the signal level established during the setting process and with a disturbance signal of 80 % amplitude. The signal is modulated with a 1 kHz sine wave, pausing to adjust the RF signal level or the switch coupling devices as necessary. Where the frequency is swept incrementally, the step size shall not exceed 1 % of the preceding frequency value.
- Attempts should be made to fully exercise the EUT during testing, and to fully interrogate all exercise modes selected for susceptibility.

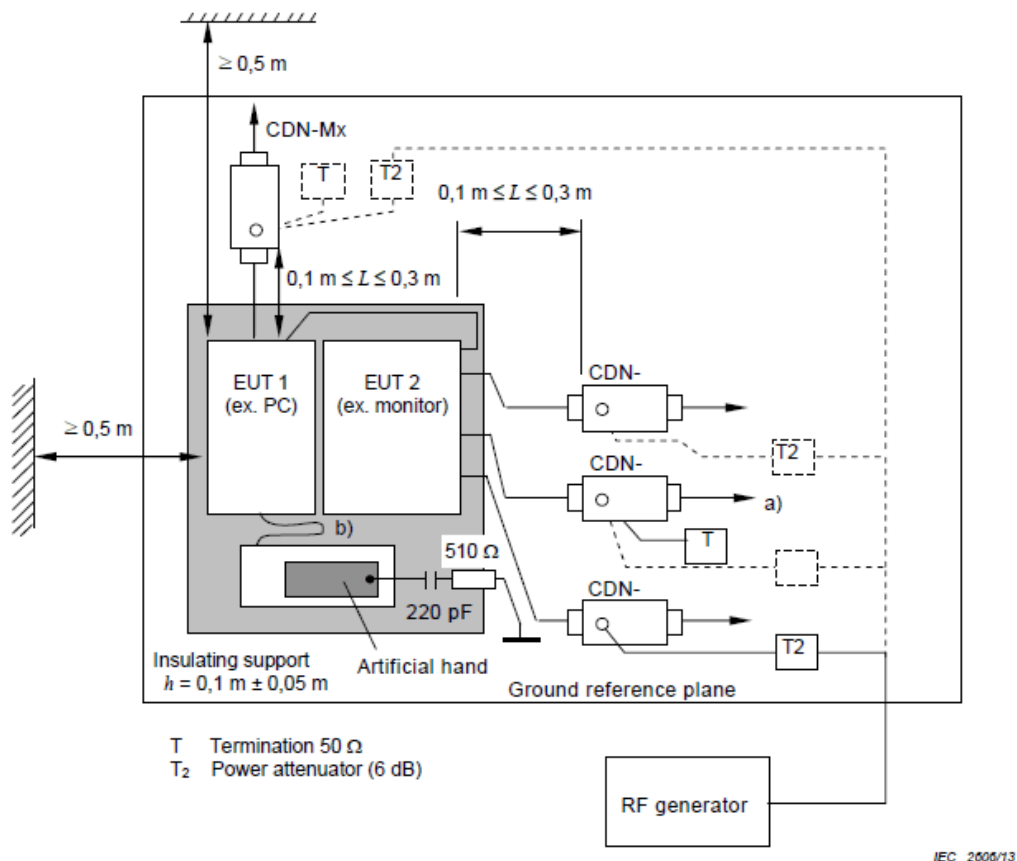

- Only one of the CDNs not used for injection shall be terminated with 50 Ω, providing only one return path. All other CDNs shall be configured as decoupling networks.
- Interconnecting cables (≤ 1 m) belonging to the EUT shall remain on the insulating support.

12.4 Test Results

| | | | |
|-------------|----------|--------------------------|----------------|
| Input Power | 12Vdc | Environmental Conditions | 24 °C, 59 % RH |
| Tested by | Koma Kuo | Test Mode | A |

| Input DC power port | | | | | | | |
|---------------------|---------------|---------------|-------------|------------------|-------------|-------------|----------------------|
| Frequency (MHz) | Level (V rms) | Modulation | Tested Line | Injection Method | Return Path | Observation | Performance Criteria |
| 0.15-80 | 10 | 80% AM (1kHz) | DC power | CDN-M2 | CDN-T8 | Note | A |

| Wired network and signal/ control port | | | | | | | |
|----------------------------------------|---------------|---------------|------------------|------------------|-------------|-------------|----------------------|
| Frequency (MHz) | Level (V rms) | Modulation | Tested Line | Injection Method | Return Path | Observation | Performance Criteria |
| 0.15-80 | 10 | 80% AM (1kHz) | LAN 1 | CDN-T8 | CDN-M2 | Note | A |
| 0.15-80 | 10 | 80% AM (1kHz) | LAN 2 | CDN-T8 | CDN-M2 | Note | A |
| 0.15-80 | 10 | 80% AM (1kHz) | LAN R | CDN-T8 | CDN-M2 | Note | A |
| 0.15-80 | 10 | 80% AM (1kHz) | ANT Left(Front) | EM-Clamp | CDN-M2 | Note | A |
| 0.15-80 | 10 | 80% AM (1kHz) | ANT Right(Front) | EM-Clamp | CDN-M2 | Note | A |
| 0.15-80 | 10 | 80% AM (1kHz) | ANT Left(Rear) | EM-Clamp | CDN-M2 | Note | A |
| 0.15-80 | 10 | 80% AM (1kHz) | ANT Right(Rear) | EM-Clamp | CDN-M2 | Note | A |

Note: The EUT is operated normal during the test.

| | | | |
|-------------|----------|--------------------------|----------------|
| Input Power | 24Vdc | Environmental Conditions | 24 °C, 59 % RH |
| Tested by | Koma Kuo | Test Mode | B |

| Input DC power port | | | | | | | |
|---------------------|---------------|---------------|-------------|------------------|-------------|-------------|----------------------|
| Frequency (MHz) | Level (V rms) | Modulation | Tested Line | Injection Method | Return Path | Observation | Performance Criteria |
| 0.15-80 | 10 | 80% AM (1kHz) | DC power | CDN-M2 | CDN-T8 | Note | A |

Note: The EUT is operated normal during the test.

| | | | |
|-------------|----------|--------------------------|----------------|
| Input Power | 36Vdc | Environmental Conditions | 24 °C, 59 % RH |
| Tested by | Koma Kuo | Test Mode | C |

| Input DC power port | | | | | | | |
|---------------------|---------------|---------------|-------------|------------------|-------------|-------------|----------------------|
| Frequency (MHz) | Level (V rms) | Modulation | Tested Line | Injection Method | Return Path | Observation | Performance Criteria |
| 0.15-80 | 10 | 80% AM (1kHz) | DC power | CDN-M2 | CDN-T8 | Note | A |

Note: The EUT is operated normal during the test.

| | | | |
|-------------|----------|--------------------------|----------------|
| Input Power | 12Vdc | Environmental Conditions | 24 °C, 54 % RH |
| Tested by | Koma Kuo | Test Mode | D |

| Input DC power port | | | | | | | |
|---------------------|---------------|---------------|-------------|------------------|-------------|-------------|----------------------|
| Frequency (MHz) | Level (V rms) | Modulation | Tested Line | Injection Method | Return Path | Observation | Performance Criteria |
| 0.15-80 | 10 | 80% AM (1kHz) | DC power | CDN-M2 | CDN-T8 | Note | A |

Note: The EUT is operated normal during the test.

13 Pictures of Test Arrangements

13.1 Conducted Disturbance at Auxiliary a.c. power ports

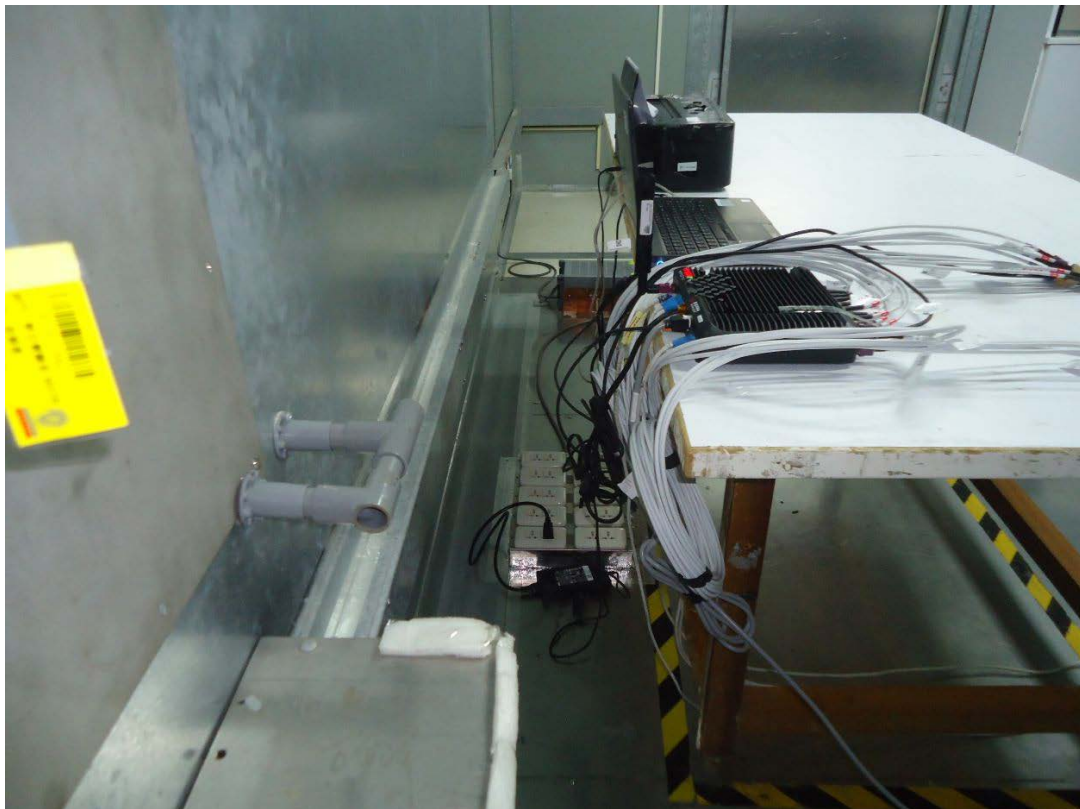

13.2 Radiated Disturbance up to 1 GHz

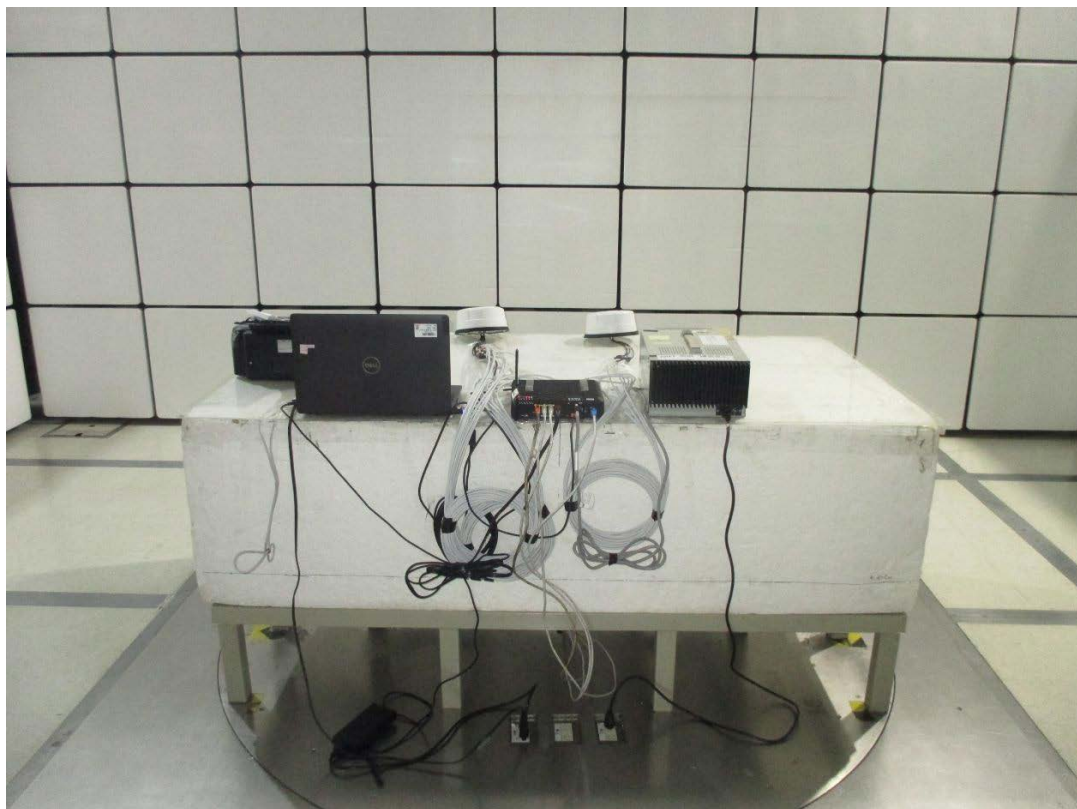

13.3 Radiated Disturbance above 1 GHz

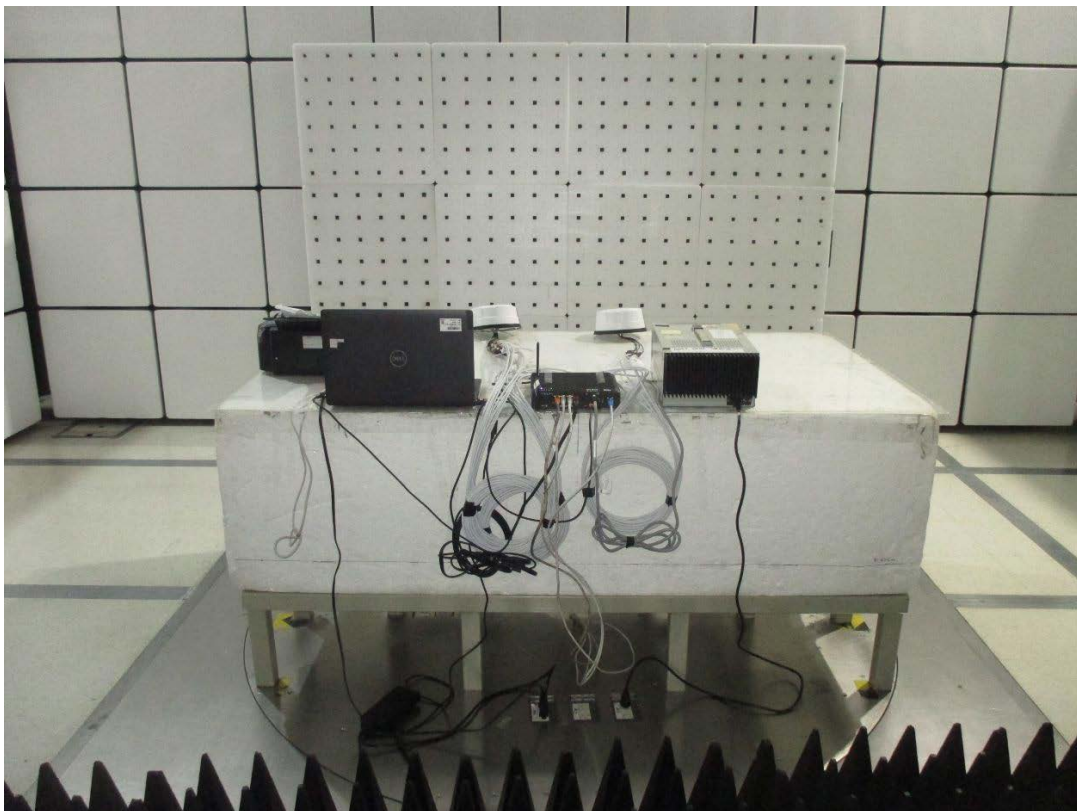

13.4 Electrostatic Discharge Immunity Test (ESD)

Mode A

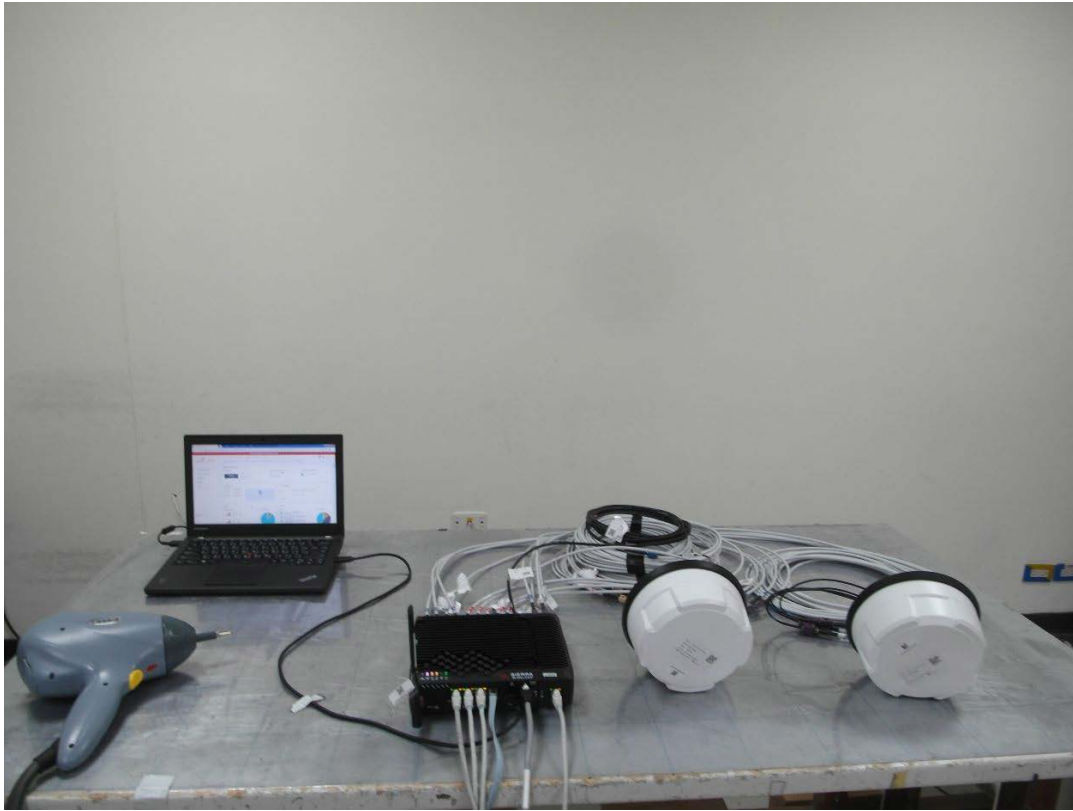

Mode B

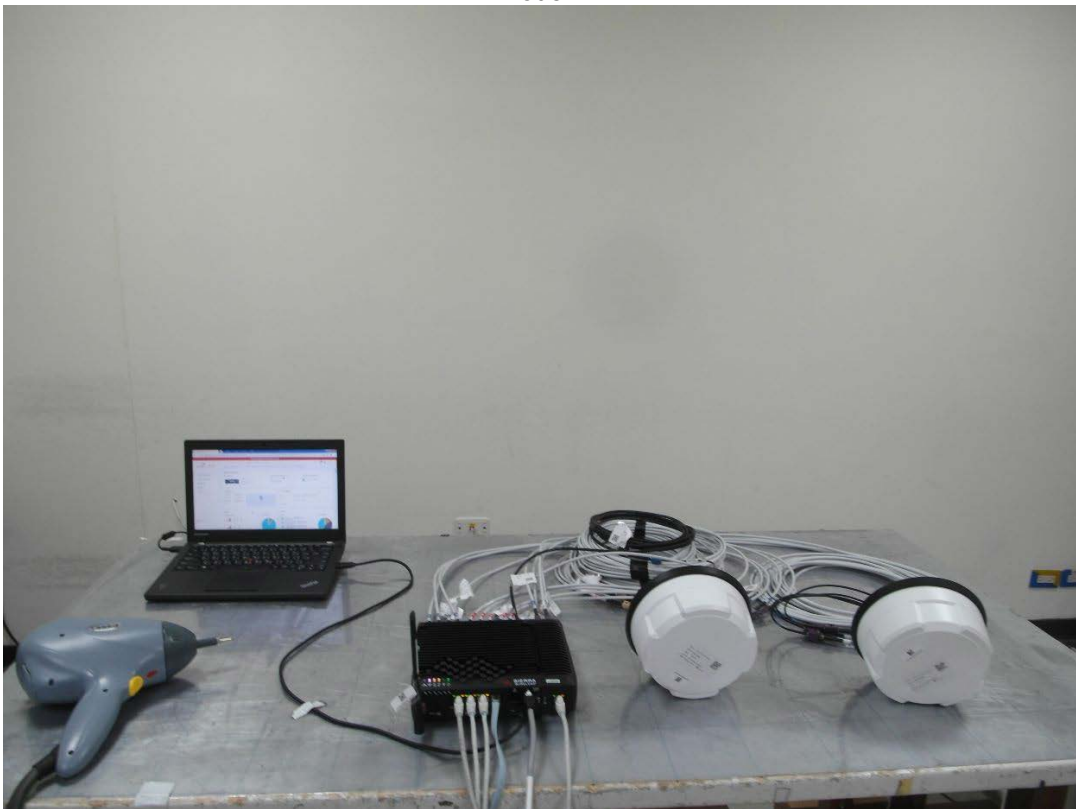

Mode C

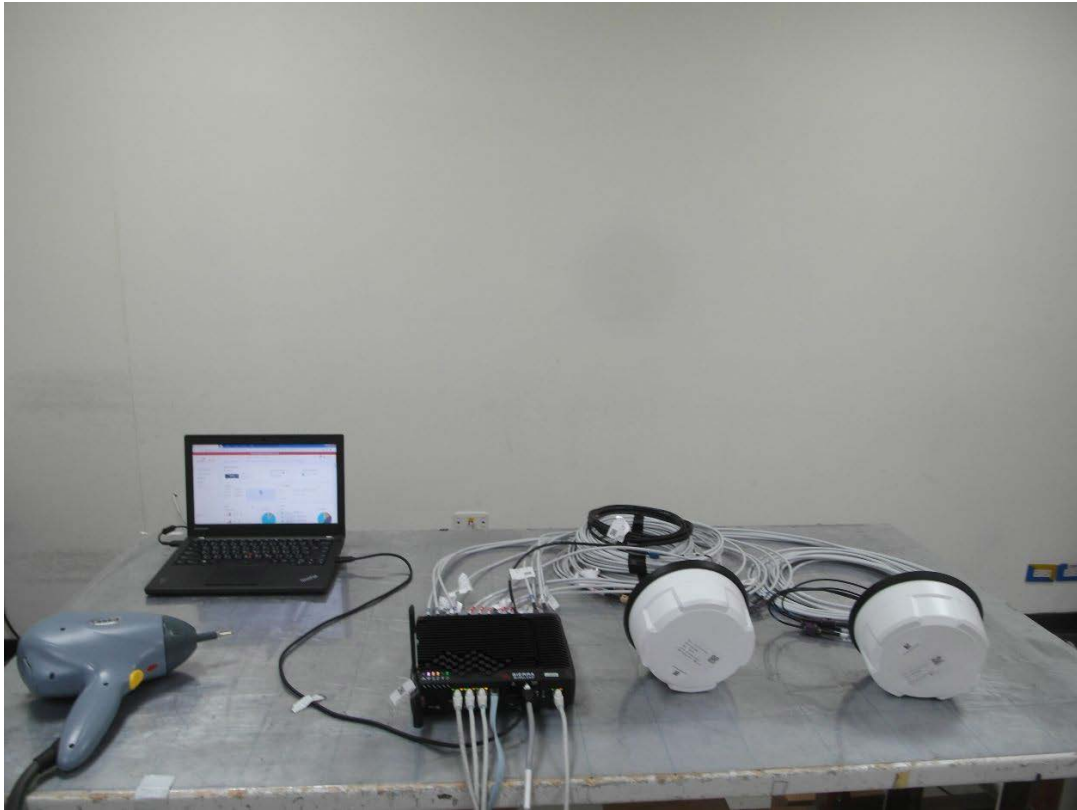

Mode D

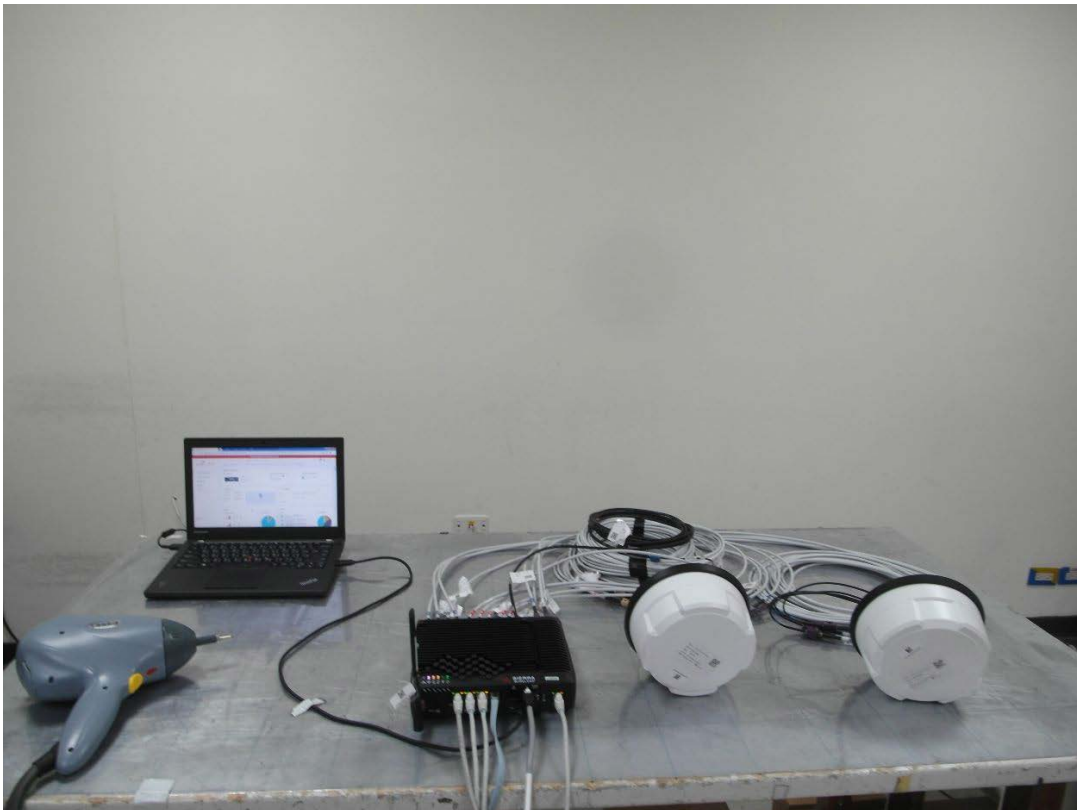

13.5 Radio-frequency, Electromagnetic Field Immunity Test (RS)

Mode A

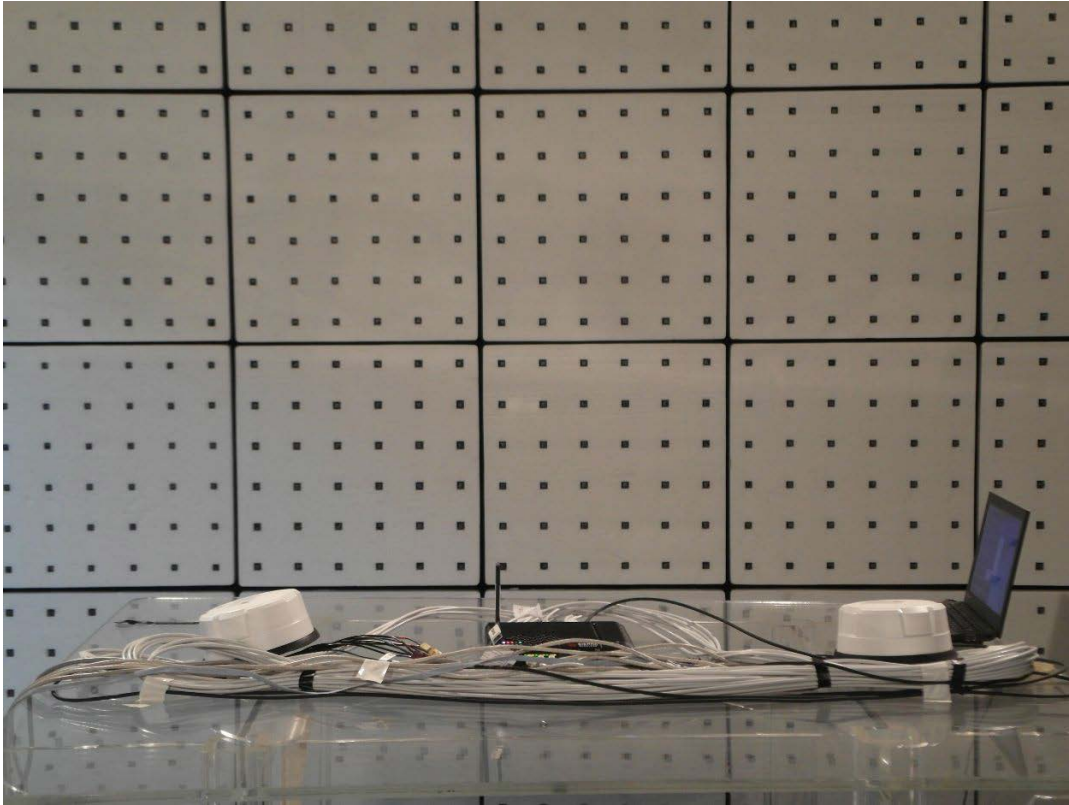

Mode B

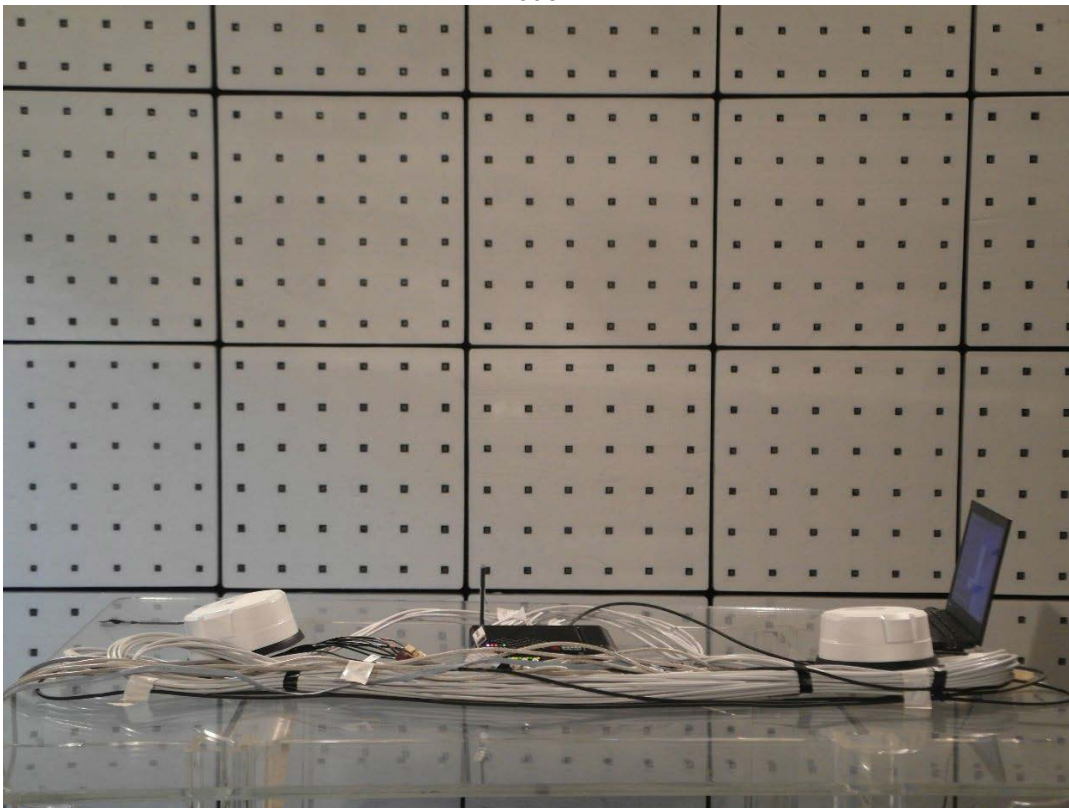

Mode C

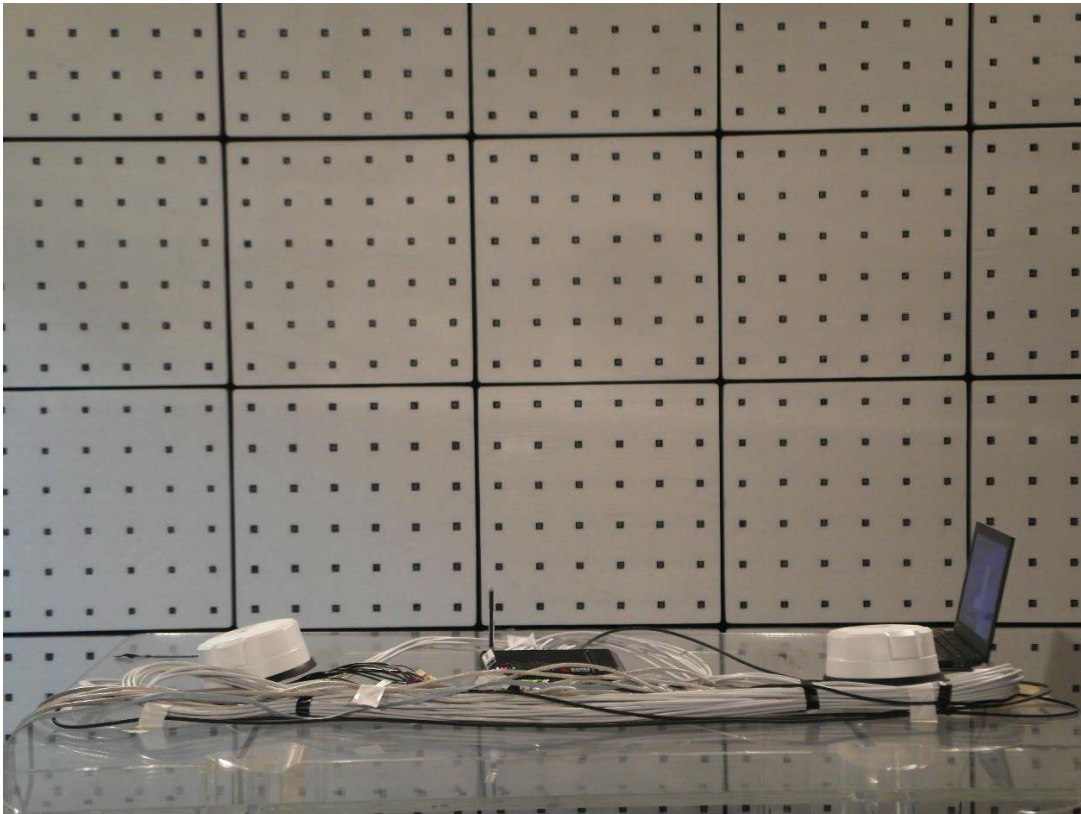

Mode D

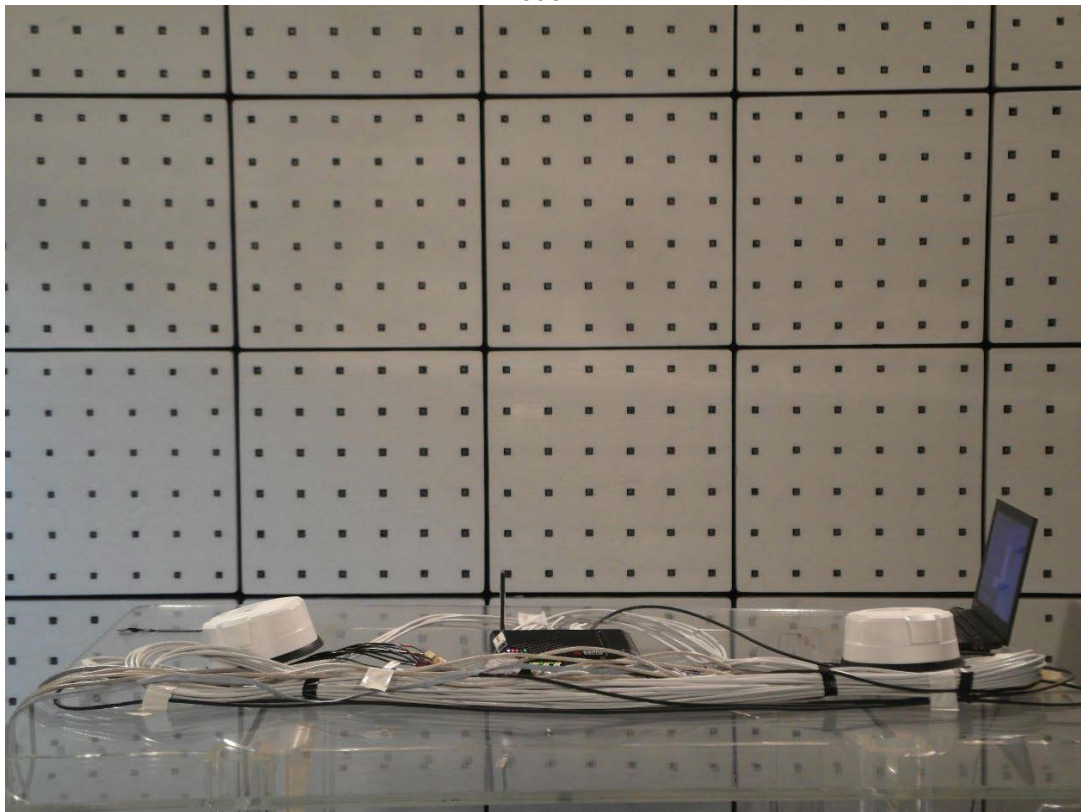

13.6 Electrical Fast Transient/Burst Immunity Test (EFT)

Mode A – DC power port



Mode A – LAN 1 port



Mode A – LAN 2 port



Mode A – LAN R port



Mode A – Antenna Left (Front) port



Mode A – Antenna Right (Front) port



Mode A – Antenna Left (Rear) port



Mode A – Antenna Right (Rear) port



Mode B – DC power port



Mode C – DC power port



Mode D – DC power port



13.7 Surge Immunity Test

Mode A



Mode B



Mode C



Mode D



13.8 Conducted Disturbances Induced by RF Fields (CS)

Mode A – DC power port



Mode A – LAN 1 port



Mode A – LAN 2 port



Mode A – LAN R port

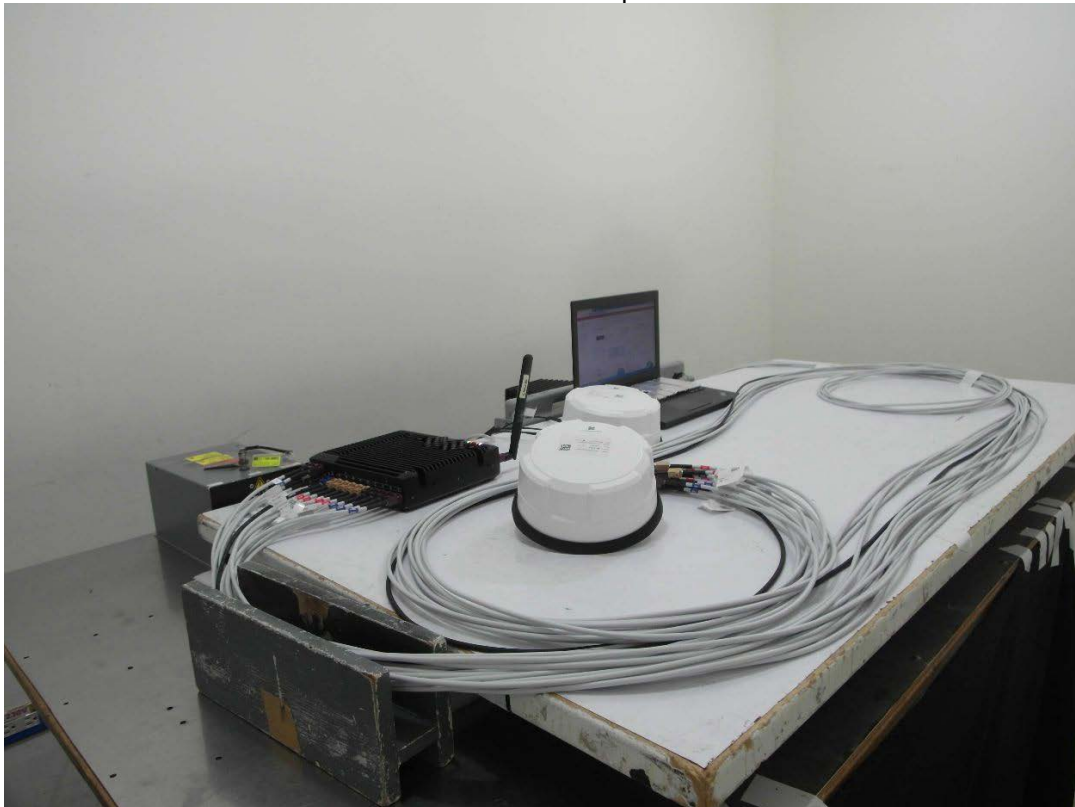

Mode A – Antenna Left (Front) port



Mode A – Antenna Right (Front) port



Mode A – Antenna Left (Rear) port

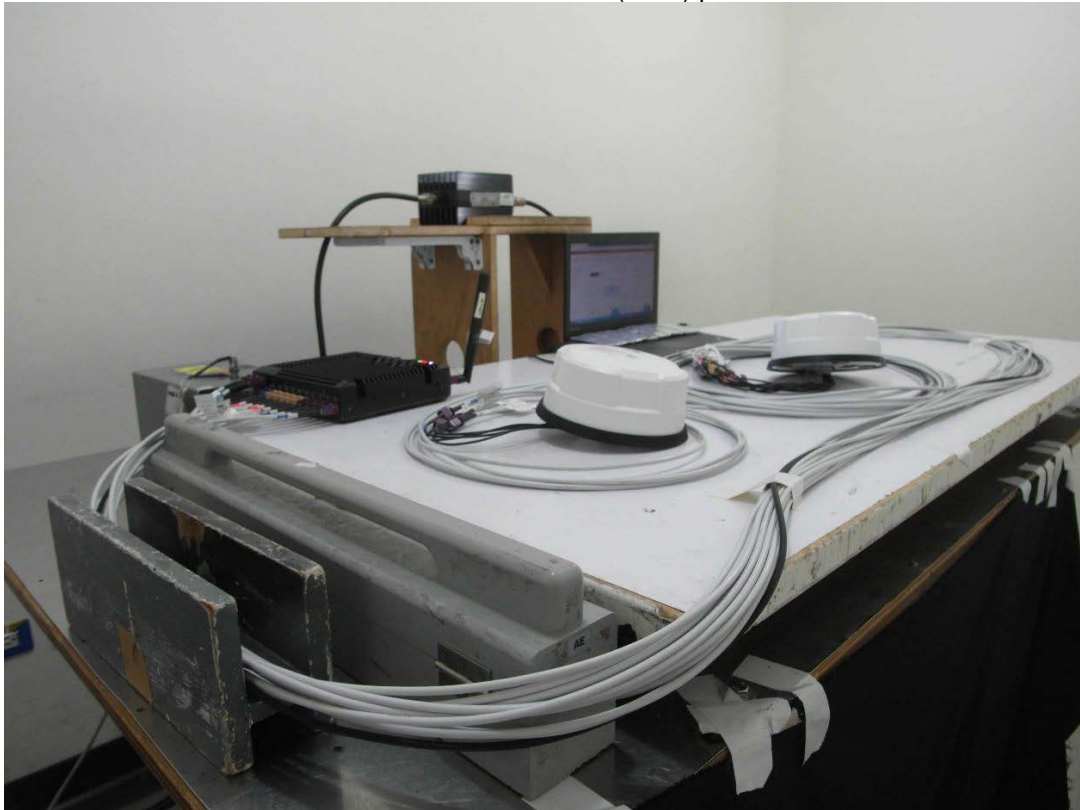

Mode A – Antenna Right (Rear) port



Mode B – DC power port



Mode C – DC power port

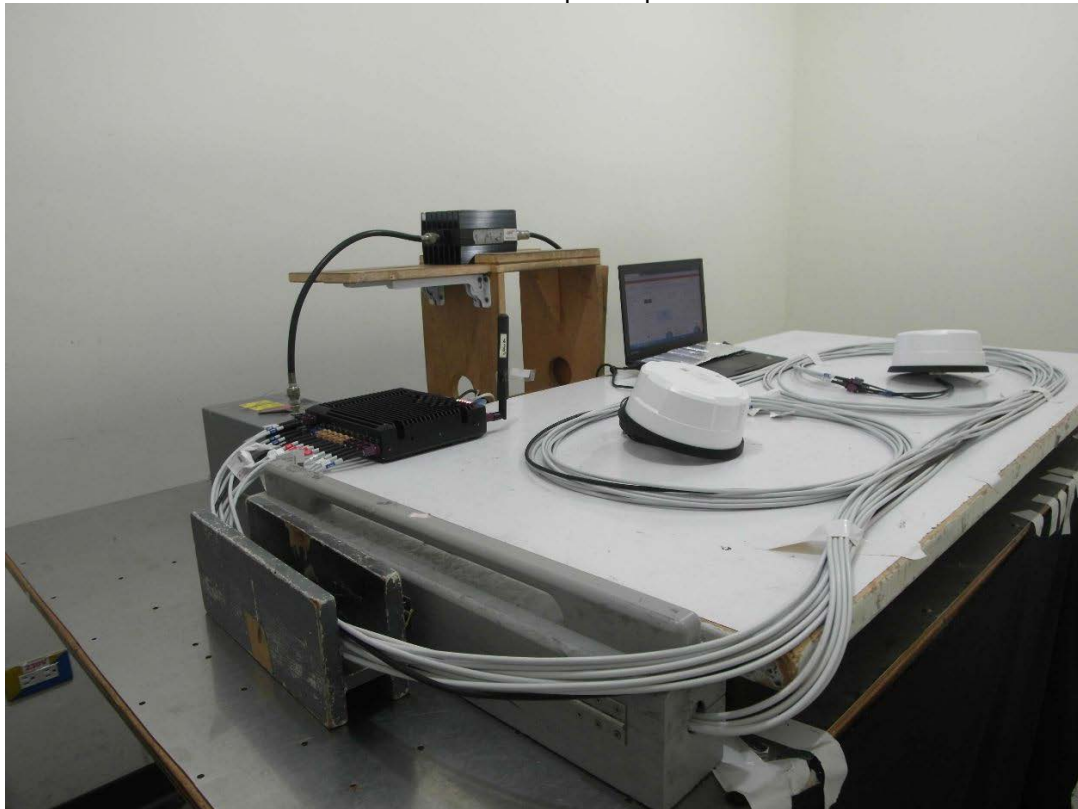

Mode D – DC power port



Appendix – Information of the Testing Laboratories

We, Bureau Veritas Consumer Products Services (H.K.) Ltd., Taoyuan Branch, were founded in 1988 to provide our best service in EMC, Radio, Telecom and Safety consultation. Our laboratories are accredited and approved according to ISO/IEC 17025.

If you have any comments, please feel free to contact us at the following:

Lin Kou EMC/RF Lab

Tel: 886-2-26052180

Fax: 886-2-26051924

Hsin Chu EMC/RF/Telecom Lab

Tel: 886-3-6668565

Fax: 886-3-6668323

Hwa Ya EMC/RF/Safety Lab

Tel: 886-3-3183232

Fax: 886-3-3270892

Email: service.adt@tw.bureauVeritas.com

Web Site: www.bureauVeritas-adt.com

The address and road map of all our labs can be found in our web site also.

--- END ---