



AirPrime XA1120

Product Technical Specification



SIERRA
WIRELESS®

41111959
Rev 4.0

Important Notice

Due to the nature of wireless communications, transmission and reception of data can never be guaranteed. Data may be delayed, corrupted (i.e., have errors) or be totally lost. Although significant delays or losses of data are rare when wireless devices such as the Sierra Wireless modem are used in a normal manner with a well-constructed network, the Sierra Wireless modem should not be used in situations where failure to transmit or receive data could result in damage of any kind to the user or any other party, including but not limited to personal injury, death, or loss of property. Sierra Wireless accepts no responsibility for damages of any kind resulting from delays or errors in data transmitted or received using the Sierra Wireless modem, or for failure of the Sierra Wireless modem to transmit or receive such data.

Safety and Hazards

Do not operate the Sierra Wireless modem in areas where blasting is in progress, where explosive atmospheres may be present, near medical equipment, near life support equipment, or any equipment which may be susceptible to any form of radio interference. In such areas, the Sierra Wireless modem **MUST BE POWERED OFF**. The Sierra Wireless modem can transmit signals that could interfere with this equipment.

Do not operate the Sierra Wireless modem in any aircraft, whether the aircraft is on the ground or in flight. In aircraft, the Sierra Wireless modem **MUST BE POWERED OFF**. When operating, the Sierra Wireless modem can transmit signals that could interfere with various onboard systems.

Note: Some airlines may permit the use of cellular phones while the aircraft is on the ground and the door is open. Sierra Wireless modems may be used at this time.

The driver or operator of any vehicle should not operate the Sierra Wireless modem while in control of a vehicle. Doing so will detract from the driver or operator's control and operation of that vehicle. In some states and provinces, operating such communications devices while in control of a vehicle is an offence.

Limitation of Liability

The information in this manual is subject to change without notice and does not represent a commitment on the part of Sierra Wireless. SIERRA WIRELESS AND ITS AFFILIATES SPECIFICALLY DISCLAIM LIABILITY FOR ANY AND ALL DIRECT, INDIRECT, SPECIAL, GENERAL, INCIDENTAL, CONSEQUENTIAL, PUNITIVE OR EXEMPLARY DAMAGES INCLUDING, BUT NOT LIMITED TO, LOSS OF PROFITS OR REVENUE OR ANTICIPATED PROFITS OR REVENUE ARISING OUT OF THE USE OR INABILITY TO USE ANY SIERRA WIRELESS PRODUCT, EVEN IF SIERRA WIRELESS AND/OR ITS AFFILIATES HAS BEEN ADVISED OF THE POSSIBILITY OF SUCH DAMAGES OR THEY ARE FORESEEABLE OR FOR CLAIMS BY ANY THIRD PARTY.

Notwithstanding the foregoing, in no event shall Sierra Wireless and/or its affiliates aggregate liability arising under or in connection with the Sierra Wireless product, regardless of the number of events, occurrences, or claims giving rise to liability, be in excess of the price paid by the purchaser for the Sierra Wireless product.

Patents

This product may contain technology developed by or for Sierra Wireless Inc. This product includes technology licensed from QUALCOMM®. This product is manufactured or sold by Sierra Wireless Inc. or its affiliates under one or more patents licensed from MMP Portfolio Licensing.

Copyright

© 2019 Sierra Wireless. All rights reserved.

Trademarks

Sierra Wireless®, AirPrime®, AirLink®, AirVantage® and the Sierra Wireless logo are registered trademarks of Sierra Wireless.

Windows® and Windows Vista® are registered trademarks of Microsoft Corporation.

Macintosh® and Mac OS X® are registered trademarks of Apple Inc., registered in the U.S. and other countries.

QUALCOMM® is a registered trademark of QUALCOMM Incorporated. Used under license.

Other trademarks are the property of their respective owners.

Contact Information

Sales information and technical support, including warranty and returns	Web: sierrawireless.com/company/contact-us/ Global toll-free number: 1-877-687-7795 6:00 am to 5:00 pm PST
Corporate and product information	Web: sierrawireless.com

Revision History

Revision number	Release date	Changes
1	January 19, 2018	Initial revision in SW FM template.
2.0	March 22, 2018	Updated: <ul style="list-style-type: none"> • Figure 4-4 on page 32 • Packaging and Handling (Tape Reel) on page 33
2.1	April 13, 2018	Updated: <ul style="list-style-type: none"> • Table 2-1 on page 16 • Figure 5-4 on page 35
2.2	April 23, 2018	Updated: <ul style="list-style-type: none"> • Overview on page 9 • Antenna Status Protocol (Antenna Advisor) on page 28
2.3	May 03, 2018	Fixed typo in Drying on page 36

Product Technical Specification

Revision number	Release date	Changes
3.0	September 27, 2018	Updated: <ul style="list-style-type: none">• Specifications on page 14• Protocols on page 21
4.0	February 19, 2019	Updated Figure 2-2 on page 15
		Deleted: <ul style="list-style-type: none">• section 5 Packing and Handling• section 6 Reflow Soldering Temperature Profile

>> Contents

Function Description	9
Overview	9
Target Applications	9
Product Highlights and Features	10
System Block Diagram	10
Multi-tone Active Interference Canceller	11
1PPS	11
AGPS for faster TTFF (EPO in flash™)	11
EASY™	11
AlwaysLocate™	12
LOCUS	12
PPS sync NMEA	13
Antenna Advisor	13
Specifications	14
Mechanical Dimensions	14
PCB Copper Pad Definition	15
Pin Configuration	15
Pin Assignment	16
Description of I/O Pins	17
Specifications	19
Absolute Maximum Ratings	20
Operating Conditions	20
Protocols	21
NMEA Output Sentences	21
GGA—Time, Position and Related data of Navigation Fix	22
GSA—GNSS DOP and Active Satellites, Including GPS (GPGSA) or BEIDOU (BDGSA)	23
GSV— Satellites in View, Including GPS (GPGSV) and BEIDOU (BDGSV)	24
RMC—Recommended Minimum Navigation Information	26
VTG—Course and Speed information Relating to the Ground	27
MTK NMEA Command Protocols	27
Antenna Status Protocol (Antenna Advisor)	28

Reference Design	29
Reference Schematic Design for Using the RTCM/I2C/SPI	29
Reference Schematic Design for the RTCM	29
Reference Schematic Design for Using I2C	30
Reference Schematic Design for the SPI Bus	31
Reference Schematic Design for Using an Active Antenna	32

List of Figures

Figure 1-1: XA1120	9
Figure 1-2: System Block Diagram	10
Figure 1-3: Operation of EASY™	12
Figure 1-4: Always Locate	12
Figure 1-5: PPS sync NMEA	13
Figure 2-1: Mechanical Dimensions.	14
Figure 2-2: PCB Copper Pad.	15
Figure 2-3: Pin Configuration.	15
Figure 4-1: UART + RTCM	29
Figure 4-2: UART + I2C	30
Figure 4-3: UART+SPI Application	31
Figure 4-4: Active Antenna Application	32

List of Tables

Table 2-1: Pin Assignment.	16
Table 2-2: WAKE UP	18
Table 2-3: NRESET	18
Table 2-4: Specification Data.	19
Table 2-5: Maximum Ranges.	20
Table 2-6: Operating Conditions	20
Table 3-1: Position Fix Indicator	21
Table 3-2: NMEA Output Sentence for GPS and GNSS	21
Table 3-3: GGA Data Format.	22
Table 3-4: Position Fix Indicator	22
Table 3-5: GGA Data Format.	23
Table 3-6: Mode 1	23
Table 3-7: Mode 2	24
Table 3-8: GPGSV Data Format	24
Table 3-9: GLGSV Data Format	25
Table 3-10: RMC Data Format.	26
Table 3-11: VTG Data Format	27
Table 3-12: Status of Antenna	28

>> | 1: Function Description

Overview

The XA1120 is a POT (Patch On Top) GNSS module that is capable of tracking GPS and BeiDou satellites simultaneously. It comes with an integrated GPS+BeiDou patch antenna that is optimized for performance in compact devices. In addition to the integrated antenna, the module also offers an external antenna interface with automatic antenna switching circuit.

The XA1120 is one of the smallest integrated antenna modules on the market with an ultra-compact size of 12.5 x 12.5 x 6.8 mm in a QFN Package. It supports multiple interfaces such as SPI and I²C that can be used instead of UART.

The module is integrated with SMPS (switched-mode power supply) which allows for the lowest possible consumption of power while offering optimum GNSS sensitivity and performance.

The XA1120 is based on latest MT3333 chipset and supports all standard GNSS features including QZSS, SBAS, Anti-Jamming, EASY™, PPS sync NMEA, LOCUS™, GLP™ and AGPS.

Target Applications

- Handheld Devices
- M2M applications
- Asset management
- Surveillance systems
- Wearable products



Figure 1-1: XA1120

Product Highlights and Features

- 33 tracking/ 99 acquisition-channel GPS +BEIDOU receiver
- Supports QZSS & SBAS(WAAS, EGNOS, MSAS, GAGAN)¹
- Sensitivity: -165dBm
- Update Rate: up to 10Hz²
- 12 multi-tone active interference canceller
- High accuracy 1-PPS timing ($\pm 20\text{ns}$ RMS) and the pulse width is 100ms
- AGPS Support for Fast TTFF (EPO in flashTM; choose from 6 hours, 3, 7, 14, or 30 days)
- EASYTM: Self-Generated Orbit Prediction for instant positioning fix
- AlwaysLocateTM Intelligent Algorithm (Advance Power Periodic Mode) for power saving
- PPS sync NMEA
- LOCUS (Embedded Logger Function)
- Automatic antenna switching function
- Antenna Advisor function
- Support interface types: I2C/ SPI/ UART (configuration)
- Consumption current(@3.3V):
 - For GPS+ BEIDOU
 - Acquisition: 25mA/ 28mA /31mA (min / typical / max)
 - Full Power Tracking: 24mA / 28mA / 32mA (min / typical / max)
- RoHS Compliant

System Block Diagram

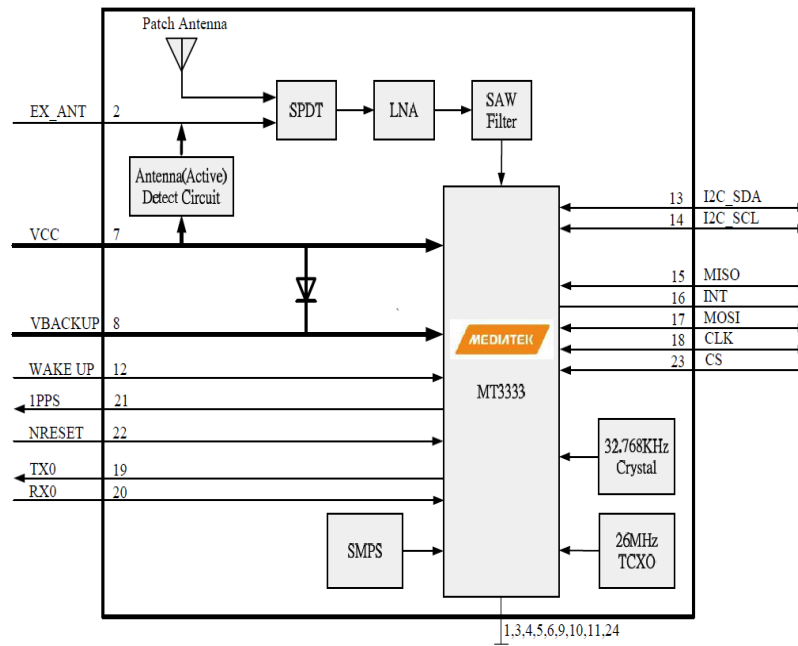

Figure 1-2: System Block Diagram

1. GAGAN will be supported upon its starting date of service.
2. SBAS can only be enabled when the update rate is less than or equal to 5Hz.

Multi-tone Active Interference Canceller

Many GNSS systems today also integrate various other RF systems such as Wi-Fi, Cellular and Bluetooth. These other radios can often generate RF harmonics which can influence the GPS reception and performance.

The embedded Multi-Tone Active Interference Canceller (MTAIC) also known as Anti-Jamming can reject such unwanted RF harmonics from nearby on-board active components. Anti-Jamming can improve the capacity of GPS reception, eliminating the need for additional hardware engineering to compensate for these interferences. This built-in feature can cancel up to 12 independent channels of continuous interference waves.

1PPS

The XA1120 generates a-pulse-per-second signal (1 PPS). It is an electrical signal which precisely indicates the start of a second with an accuracy of ± 20 ns RMS (Root Mean Square). The PPS signal is provided through a designated output pin for many external applications.

AGPS for faster TTFF (EPO in flash™)

The AGPS (EPO in flash™) provides predicated EPO (Extended Prediction Orbit) data to speed up TTFF (Time-To-First-Fix). This feature is useful when satellite signal is weak. AGPS can be downloaded from an FTP server via the Internet or through a wireless network. The GPS engine in the module will use EPO data to assist with position calculation when navigation information from satellites is insufficient. For more details on EPO, please refer to our AGPS application note.

EASY™

EASY™ (Embedded Assist System) is for quick positioning/TTFF when information received from the satellites is insufficient (e.g. in a weak signal). When EASY™ is enabled, the GPS engine will automatically calculate and then predict single ephemeris up to three days. The predicted information will be saved into the memory and the GPS engine will then use the saved information for later positioning. Backup power (VBACKUP) is required for EASY™.

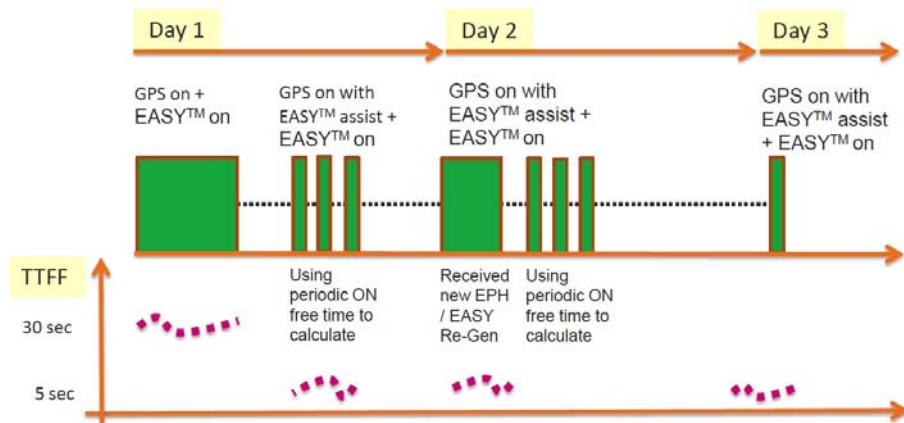

Figure 1-3: Operation of EASY™

Figure 1-3 shows that when the module obtains information from GPS satellites, the GPS engine will start to pre-calculate and predict orbits automatically for the next three days.

AlwaysLocate™

In *AlwaysLocate™* mode, the on/off time can be adjusted adaptively to achieve a balance between positioning accuracy and power consumption depending on various environmental conditions.

Figure 1-4 gives some insight on power savings in different cases when *AlwaysLocate™* mode is enabled.

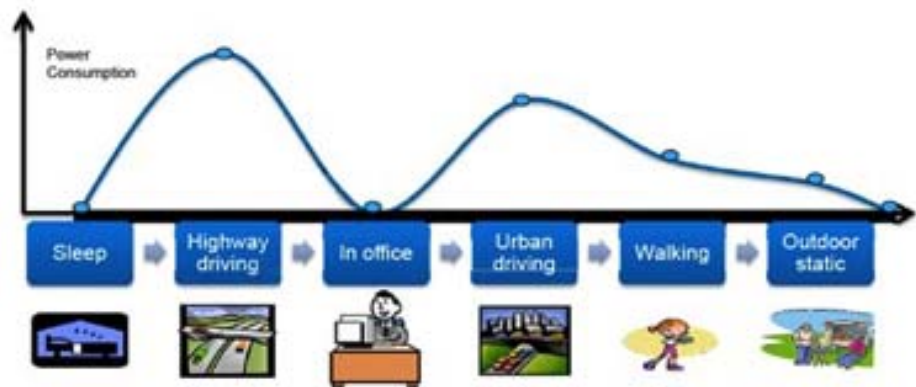

Figure 1-4: Always Locate

LOCUS

LOCUS (Embedded Logger) function enables, GNSS module to become a logger-capable device. It does not need any host or external flash data format such as UTC, latitude, longitude, valid or checksum for GPS data logging. The maximum log duration is up to two days under *AlwaysLocate™*.

PPS sync NMEA

Pulse-Per-Second (PPS) VS. NMEA can be used in the time service. The latency range of the beginning of UART Tx is between 465ms to 485 ms at the MT3333 and behind the rising edge of PPS.

The PPS sync NMEA only supports 1Hz NMEA output and a baud rate of 115200 to 14400 bps. For baud rates of 9600 bps and 4800 bps, only the RMC NMEA sentence is supported. If NMEA sentence outputs are supported even at the low baud rate, per-second transmission may exceed the threshold of one second.

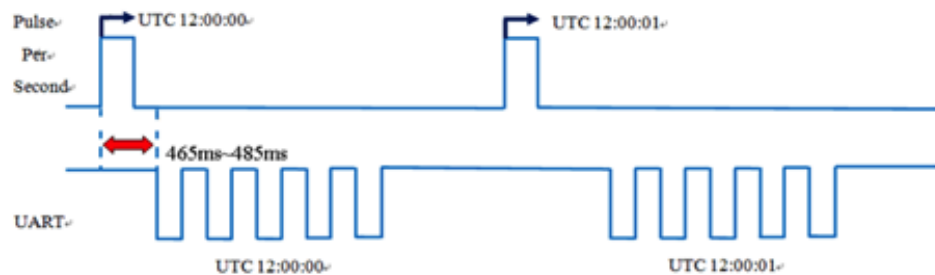

Figure 1-5: PPS sync NMEA

Antenna Advisor

“Antenna Advisor” is a new antenna support feature which is designed to detect and provide the antenna status using software (through a proprietary protocol as described below in [Antenna Status Protocol \(Antenna Advisor\)](#)).

Antenna Advisor can detect and notify about the following changes:

- When using Internal Antenna
- When using External Active Antenna

2: Specifications

Mechanical Dimensions

Dimension: (Unit: mm, Maximum height: 6.8 mm)

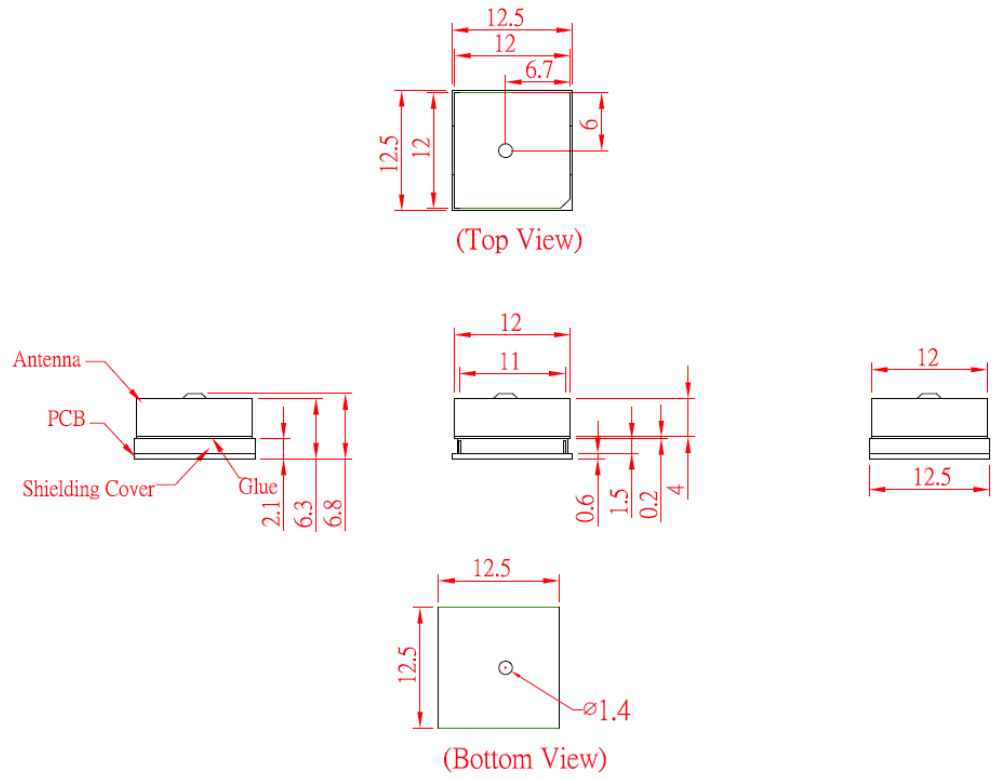

Figure 2-1: Mechanical Dimensions

PCB Copper Pad Definition

(Unit: mm, Tolerance: 0.1mm)

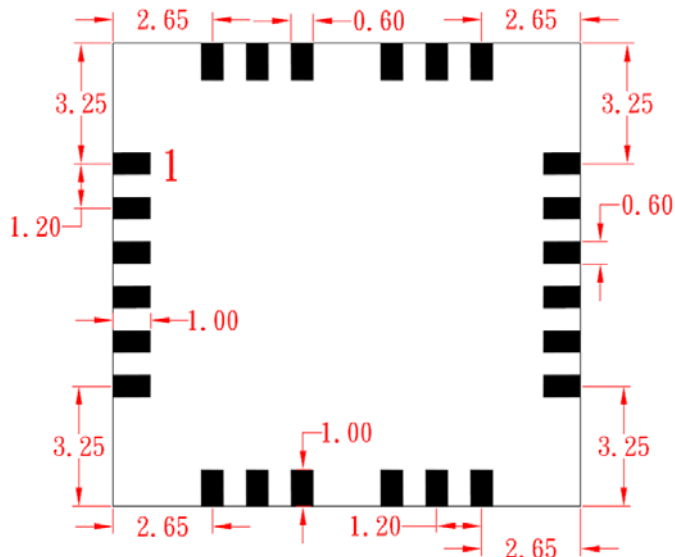

Figure 2-2: PCB Copper Pad

Pin Configuration

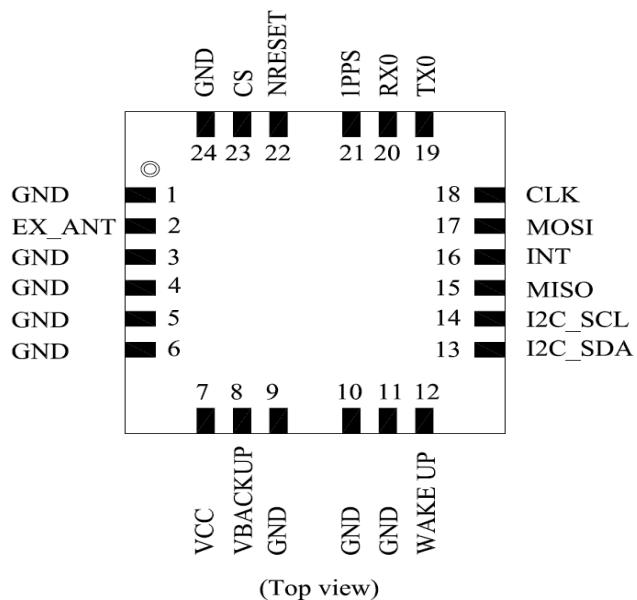

Figure 2-3: Pin Configuration

Pin Assignment

Table 2-1: Pin Assignment

Pin	Name	I/O	Description and Note	Active Low/High	IO Voltage Domain	Reset State ^a	Recommendation for Unused Pad
1	GND	P	Ground		0V		Mandatory connection
2	EX_ANT	I PO	External active antenna RF input. DC power from VCC and provide for external active antenna		3.3V		
3	GND	P	Ground		0V		Mandatory connection
4	GND	P	Ground		0V		Mandatory connection
5	GND	P	Ground		0V		Mandatory connection
6	GND	P	Ground		0V		Mandatory connection
7	VCC	PI	Main DC power input		3.3V		Mandatory connection
8	VBACKUP	PI	Backup power input for RTC and navigation data keep		3.0V		Connection to C=1 μ F
9	GND	P	Ground		0V		Mandatory connection
10	GND	P	Ground		0V		Mandatory connection
11	GND	P	Ground		0V		Mandatory connection
12	WAKE UP	PI	Wake up from power saving	H	0V		Connection to R=10k Ω
13	I2C_SDA	I/O	I ² C Serial data (in slave mode)		2.8V	O, PU	Left open
14	I2C_SCL	I	I ² C Serial clock (in slave mode)		2.8V	I, PU	Left open
15	MISO	O	SPI serial data output (in slave mode)		2.8V	O, PU	Left open
16	INT	O	Interrupt pin for SPI or I ² C		2.8V	O, PU	Left open
17	MOSI	I	SPI serial data input (in slave mode)		2.8V	I, PU	Left open
18	CLK	I	SPI serial clock		0V	I, PD	Left open
19	TX0	O	Serial Data Output for NMEA output (TTL)		2.8V	O, PU	Mandatory connection
20	RX0	I	Serial Data Input for Firmware update (TTL)		2.8V	I, PU	Mandatory connection
21	1PPS	O	1PPS Time Mark Output		2.8V	O, PU	Left open
22	NRESET	I	Reset Input	L	2.8V	I, PU	Left open

Table 2-1: Pin Assignment (Continued)

Pin	Name	I/O	Description and Note	Active Low/High	IO Voltage Domain	Reset State ^a	Recommendation for Unused Pad
23	CS	I	SPI serial chip select	L	2.8V	I, PU	Left open
24	GND	P	Ground		0V		Mandatory connection

a. I = Input, O = Output, PU = Pull up, PD = Pull Down, H = High, T = High Impedance

Description of I/O Pins

- **Pin1:** GND (Ground)
- **Pin2:** EX_ANT
 - When a 4mA or higher current is detected, the detect circuit will acknowledge the external antenna as being present and will use the external antenna for reception. DC power from VCC will be provided for the external active antenna (Recommended voltage: 3.3V).
- **Pin3:** GND (Ground)
- **Pin4:** GND (Ground)
- **Pin5:** GND (Ground)
- **Pin6:** GND (Ground)
- **Pin7:** VCC
 - Main DC power supply (3.0V to 4.3V; typical: 3.3V). The ripple must be controlled under 50mVpp.
- **Pin8:** VBACKUP
 - This connects to the backup power of the GNSS module. A power source (such as a battery) connected to this pin will help the GNSS chipset in keeping its internal RTC running when the main power source is turned off. The voltage ranges from 2.0V~4.3V (typical: 3.0V).
 - This pin is also available when VCC is connected to a power supply.
 - VBACKUP functions with a shottky diode and limited-current resistor.
 - If VBACKUP power is not reserved, the GNSS module will perform a lengthy cold start each time it is powered on, as previous satellite information is not retained and needs to be re-transmitted.
 - If not used, keep this pin floating.
- **Pin9:** GND (Ground)
- **Pin10:** GND (Ground)
- **Pin11:** GND (Ground)
- **Pin12:** WAKE UP
 - Active on High will wake up the module from backup (power-saving) mode.
 - The PMTK225 command is recommended for use with WAKEUP pin for power saving. For more details please refer to AirPrime XM_XA Series Software User Guide.

Table 2-2: WAKE UP

Symbol	Min (V)	Typ (V)	Max (V)
High	-	0	-
Low	1.2	2.8	3.4

- **Pin13:** I²C_SDA (I²C; outputs GPS information/RTCM_TX)
- **Pin14:** I²C_SCL (RTCM_RX)
 - This pin can be modified through firmware customization.
 - The *default* of this pin is defined to I²C_SCL. It will receive the clock for the I²C application.
 - If the pin is customized to RTCM, it will receive DGPS/RTCM (TTL level).
 - If not used, keep this pin floating.
- **Pin15:** MISO (SPI; outputs GPS information)
- **Pin16:** INT
 - This is the interrupt sync pin of the module. It is used to determine whether NMEA is stored in SPI/I²C buffer.
 - If NMEA data is ready and stored in SPI/I²C buffer, the pin will pull high.
 - After entire NMEA packet of one second is read, the pin will pull low.
 - When this interrupt is used and an IRQ routine is registered, the CPU usage must be checked and the programming routine adjusted.
- **Pin17:** MOSI (SPI; to receive commands from system)
- **Pin18:** CLK (SPI; to receive clock time from system)
- **Pin19:** TX0 (UART 0 transmitter; outputs GPS information for application)
- **Pin20:** RX0 (UART 0 receiver; to receive commands from host)
- **Pin21:** 1PPS
 - This pin provides one pulse-per-second signal output. If not used, keep this pin floating.
- **Pin22:** NRESET
 - Active on Low; it causes the module to reset. If not used, keep floating.

Table 2-3: NRESET

Symbol	Min (V)	Typ (V)	Max (V)
Low	0	0	1.5
High	2	2.8	3.3

- **Pin23:** CS (SPI; to select chip for system)
 - Active on Low to enable SPI.
- **Pin24:** GND (Ground)

Specifications

Table 2-4: Specification Data

Description	
GNSS Solution	MTK MT3333
Frequency	GPS L1, 1575.42MHz BEIDOU B1, 1561.098MHz
Sensitivity (GPS portion)	Acquisition: -148dBm, cold start Reacquisition: -163dBm, Hot start Tracking: -165dBm
SV Number GPS BEIDOU	#1~32 #1~30 (see Chapter 3 for Details)
TTFF (GPS, No. of SVs>4, C/N>40dB, PDop<1.5)	Hot start: 1 second typical Warm start: 33 seconds typical Cold start: 35 seconds typical, 60 seconds Max
Position Accuracy	Without aid: 3m (50% CEP) DGPS (SBAS(WAAS,EGNOS,MSAS, GAGAN)):2.5m (50% CEP)
Velocity Accuracy	Without aid: 0.1m/s DGPS(SBAS(WAAS,EGNOS,MSAS, GAGAN)):0.05m/s
Timing Accuracy (1PPS Output)	±20ns RMS within 100ms in one pulse
Altitude	10,000m maximum (Normal mode: Car/ Pedestrian/ Aviation) 80,000m maximum (Balloon mode)
Velocity	Maximum 515m/s (1000 knots)
Acceleration	Maximum 4G
Update Rate	1Hz (default), maximum 10Hz
Baud Rate	115200 bps (default)
DGPS	SBAS (default) [WAAS, EGNOS, MSAS, GAGAN]
Power Supply	VCC: 3V to 4.3V; VBACKUP: 2.0V to 4.3V
Current Consumption @ 3.3V,1Hz Update Rate	GPS + BEIDOU: Acquisition: 25mA/ 28mA /31mA (min / typical / max) Full Power Tracking: 24mA / 28mA /32mA (min / typical / max) GLP (GNSS low-power) Tracking: 9mA / 15mA / 31mA (min / typical / max)
Backup Power Consumption @ 3V	17µA (TYP)
Power Saving (Periodic)	Backup mode: 1.2mA (TYP) Standby mode: 1.6mA (TYP)
NRESET Current @ 3.3V	9mA(TYP)
Working Temperature	-40 °C to +85 °C
Dimension	12.5 x 12.5 x 6.8 mm, SMD
Weight	4g

Absolute Maximum Ratings

The maximum power supply voltage is 4.3 VDC.

Table 2-5: Maximum Ranges

	Symbol	Min	Typ	Max	Unit
Power Supply Voltage	VCC	3.0	3.3	4.3	V
Backup Battery Voltage	VBACKUP	2.0	3.0	4.3	V

Operating Conditions

Table 2-6: Operating Conditions

	Condition	Min	Typ	Max	Unit
Operation Supply Ripple Voltage	-	-	-	50	mVpp
RX0 TTL H Level	-	2.0	-	3.3	V
RX0 TTL L Level	-	0	-	0.8	V
TX0 TTL H Level	-	2.4	-	3.3	V
TX0 TTL L Level	-	0	-	0.4	V

>> 3: Protocols

NMEA Output Sentences

Table 3-1 lists all NMEA output sentences specifically developed and defined by MTK for MTK’s products.

Table 3-1: Position Fix Indicator

Option	Description
GGA	Time, position and fix type data.
GSA	GNSS receiver operating mode, active satellites used in the position solution and DOP values.
GSV	The number of GPS satellites in view, satellite ID numbers, elevation, azimuth, and SNR values.
RMC	Time, date, position, course and speed data. The recommended minimum navigation information.
VTG	Course and speed information relative to the ground.

Table 3-2 lists NMEA output sentences used in GPS system and BEIDOU system:

Table 3-2: NMEA Output Sentence for GPS and GNSS

System	GGA	GSA	GSV	RMC	VTG
GPS	GPGGA	GPGSA	GPGSV	GPRMC	GPVTG
BEIDOU	BDGGA	BDGSA	BDGSV	BDRMC	BDVTG
GNSS (GPS+BEIDOU)	GNGGA	GPGSA +BDGSA	GPGGSV +BDGSV	GNRMC	GNVTG

GGA—Time, Position and Related data of Navigation Fix

Table 3-3 explains the NMEA sentence below:

```
$GNGGA,064951.000,2307.1256,N,12016.4438,E,1,8,0.95,39.9,M,17.8,M,*65
```

Table 3-3: GGA Data Format

Name	Example	Units	Description
Message ID	\$GNGGA		GGA protocol header
UTC Time	064951.000		hhmmss.sss
Latitude	2307.1256		ddmm.mmmm
N/S Indicator	N		N North or S South
Longitude	12016.4438		dddmm.mmmm
E/W Indicator	E		E East or W West
Position Fix Indicator	1		See Table 3-4
Satellites Used	8		
HDOP	0.95		Horizontal Dilution of Precision
MSL Altitude	39.9	meter	Antenna Altitude above/below mean-sea-level
Units	M	meter	Units of antenna altitude
Geoidal Separation	17.8	meter	
Units	M	meter	Units of geoids separation
Age of Diff. Corr.		second	Null fields when DGPS is not used
Checksum	*65		
<CR> <LF>			End of message termination

Table 3-4: Position Fix Indicator

Value	Description
0	Fix not available
1	GPS Fix
2	Differential GPS Fix

GSA—GNSS DOP and Active Satellites, Including GPS (GPGSA) or BEIDOU (BDGSA)

Table 3-5 explains the example NMEA sentences below:

GPS satellite system:

```
$GPGSA,A,3,29,21,26,15,18,09,06,10,,,,,2.32,0.95,2.11*1B
```

```
$BDGSA,A,3,14,08,10,06,,,,,,,1.24,0.87,0.88*11
```

Table 3-5: GGA Data Format

Name	Example	Units	Description
Message ID	\$GPGSA, or \$BDGSA		GSA protocol header
Mode 1	A		See Table 3-6
Mode 2	3		See Table 3-7
Satellite Used^a	29		SV on Channel 1
Satellite Used	21		SV on Channel 2
....
Satellite Used			SV on Channel 12
PDOP	2.32		Position Dilution of Precision
HDOP	0.95		Horizontal Dilution of Precision
VDOP	2.11		Vertical Dilution of Precision
Checksum	*1B		
<CR> <LF>			End of message termination

a. GPS SV No. #01~#32
Beidou SV No. #1~#30

Table 3-6: Mode 1

Value	Description
M	Manual—forced to operate in 2D or 3D mode
A	2D Automatic—allowing to switch to 2D/3D mode automatically

Table 3-7: Mode 2

Value	Description
1	Fix not available
2	2D (<4 SVs used)
3	3D (>=4 SVs used)

GSV— Satellites in View, Including GPS (GPGSV) and BEIDOU (BDGSV)

Table 3-8 explains the example NMEA sentences below:

\$GPGSV,4,1,14,28,75,321,44,42,54,137,39,20,53,080,44,17,40,30,44*77

\$GPGSV,4,2,14,04,33,253,43,32,28,055,41,08,26,212,40,11,14,055,33*7F

\$GPGSV,4,3,14,10,12,198,,07,06,179,38,23,04,125,44,27,02,314,*7E

\$GPGSV,4,4,14,193,,,42,01,,,36*45

\$BDGSV,3,1,10,08,53,009,42,06,47,168,39,10,33,225,32,14,28,067,44*61

\$BDGSV,3,2,10,09,24,189,33,07,23,194,31,05,18,258,,03,,,44*5F

\$BDGSV,3,3,10,13,,,43,02,,,34*69

Table 3-8: GPGSV Data Format

Name	Example	Units	Description
Message ID	\$GPGSV		GSV protocol header
Number of Messages	4		(Depending on the number of satellites tracked, multiple messages of GSV data may be required) ^a
Message Number	1		
Satellites in View	14		
Satellite ID	28		Channel 1 (Range 1 to 32)
Elevation	75	degrees	Channel 1 (Maximum 90)
Azimuth	321	degrees	Channel 1 (True, Range 0 to 359)
SNR (C/No)	44	dB-Hz	Range 0 to 99, (null when not tracking)
....

Table 3-8: GPGSV Data Format (Continued)

Name	Example	Units	Description
Satellite ID	17		Channel 4 (Range 1 to 32)
Elevation	40	degrees	Channel 4 (Maximum 90)
Azimuth	330	degrees	Channel 4 (True, Range 0 to 359)
SNR (C/No)	44	dB-Hz	Range 0 to 99, (null when not tracking)
Checksum	*77		
<CR><LF>			End of message termination

a. One GSV sentence can only receive up to four SVs

[Table 3-9](#) explains the example sentences below:

```
$GPGSV,1,1,14,28,75,321,44*77
$BDGSV,1,1,10,09,24,189,33,07,23,194,31,05,18,258,,03,,,44*5
F
```

Table 3-9: GLGSV Data Format

Name	Example	Units	Description
Message ID	\$GPGSV		GSV protocol header
Number of Messages	1		(Depending on the number of satellites tracked, multiple messages of GSV data may be required) ^a
Message Number	1		
Satellites in View	14		
Satellite ID	28		Channel 1 (Range 1 to 32)
Elevation	75	degrees	Channel 1 (Maximum 90)
Azimuth	321	degrees	Channel 1 (True, Range 0 to 359)
SNR(C/No)	44	dB-Hz	Range 0 to 99, (null when not tracking)
Checksum	*77		
<CR> <LF>			End of message termination

a. One GSV sentence can only receive up to four SVs

RMC—Recommended Minimum Navigation Information

Table 3-10 explains the example NMEA sentence below:

```
$GNRMC,064951.000,A,2307.1256,N,12016.4438,E,0.03,165.48,260406,3.05,W,A*2C
```

Table 3-10: RMC Data Format

Name	Example	Units	Description
Message ID	\$GNRMC		RMC protocol header
UTC Time	064951.000		hhmmss.sss
Status	A		A: data valid V: data not valid
Latitude	2307.1256		ddmm.mmmm
N/S Indicator	N		N: North S: South
Longitude	12016.4438		dddmm.mmmm
E/W Indicator	E		E: East W: West
Speed over Ground	0.03	Knots/hr	
Course over Ground	165.48	degrees	TRUE
Date	260406		ddmmyy
Magnetic Variation	3.05, W	degrees	E: East W: West (By Customization)
Mode	A		A: Autonomous mode D: Differential mode E: Estimated mode
Checksum	*2C		
<CR> <LF>			End of message termination
Message ID	\$GNRMC		RMC Protocol header

VTG—Course and Speed information Relating to the Ground

Table 3-11 explains the example sentence below:

```
$GNVTG,165.48,T,,M,0.03,N,0.06,K,A*37
```

Table 3-11: VTG Data Format

Name	Example	Units	Description
Message ID	\$GNVTG		VTG protocol header
Course	165.48	degrees	Measured heading
Reference	T		TRUE
Course		degrees	Measured heading
Reference	M		Magnetic Variation (By Customization)
Speed	0.03	Knots/hr	Measured horizontal speed
Units	N		Knots
Speed	0.06	km/hr	Measured horizontal speed
Units	K		Kilometers per hour
Mode	A		A: Autonomous mode D: Differential mode E: Estimated mode
Checksum	*37		
<CR> <LF>			End of message termination

MTK NMEA Command Protocols

Packet Type: 103 PMTK_CMD_COLD_START

Packet Meaning: Cold Start --- Discarding the data of Time, Position, Almanacs and Ephemeris at re-start.

Example: \$PMTK103*30<CR><LF>

Note: Please refer to the XM_XA Software User Guide document for more details.

Antenna Status Protocol (Antenna Advisor)

Package Type: Status of Antenna

Table 3-12: Status of Antenna

Name	Example	Units	Description
Message ID	\$PGCMD		Protocol Header
Command ID	203		Function Type

Example:

\$PGCMD , 203<CR><LF>

Used **Patch antenna** status: PGACK,SW_ANT_Internal.

Used **Active antenna** status: PGACK,SW_ANT_External.

>> 4: Reference Design

This section introduces the reference schematic design for best performance. For additional design guidelines please refer to the Hardware Design Guide document for specific model.

Reference Schematic Design for Using the RTCM/I²C/SPI

The XA1120 provides several interfaces to process GNSS NMEA data (by specified firmware):

1. UART0 + RTCM (for DGPS data)
2. UART0 + I²C (for NMEA data)
3. UART0 + SPI (for NMEA data)

Reference Schematic Design for the RTCM

Figure 4-1 provides a schematic reference design for the RTCM:

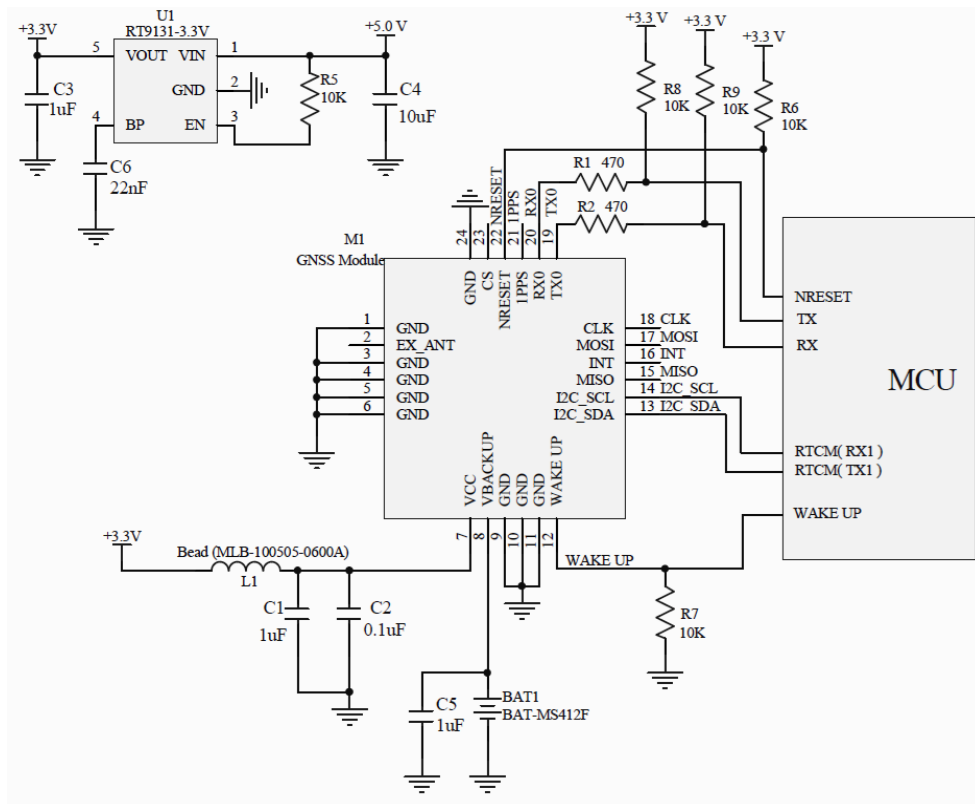

Figure 4-1: UART + RTCM

Notes:

1. Ferrite bead L1 is added for power noise reduction. Use one with an equivalent impedance (600Ω at 100MHz; IDC 200mA).
2. Place C1, C2 and C5 bypass-capacitors as close as possible to the module.
3. Damping resistors R1 and R2 can be modified to manage EMI for system application.
4. The default of Pull-low resistor R7 is set at a low level for the WAKE UP pin to function.

Reference Schematic Design for Using I²C

Figure 4-2 provides a schematic reference design for using I²C:

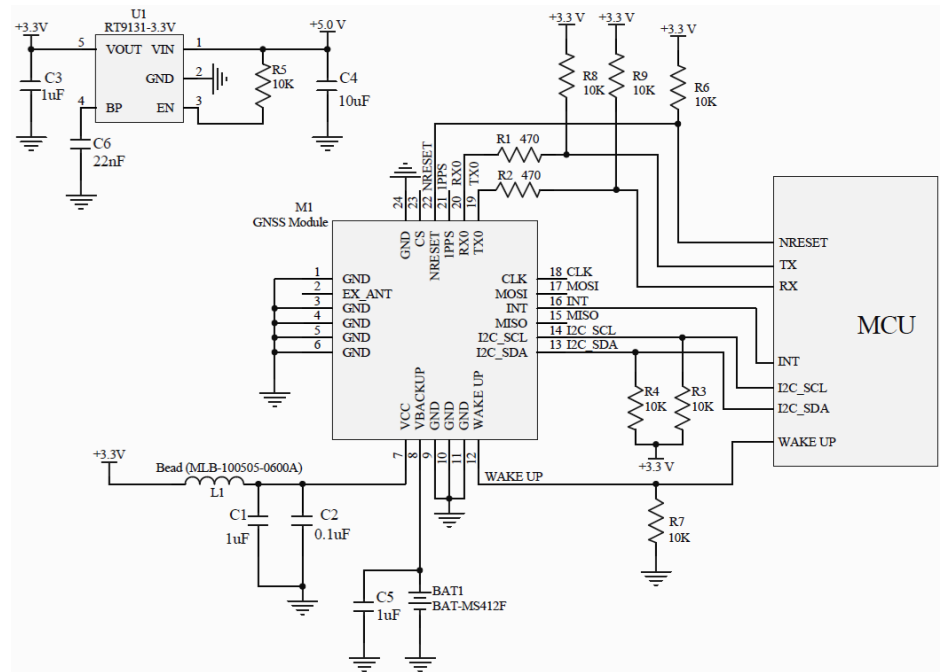

Figure 4-2: UART + I²C

Notes:

1. Ferrite bead L1 is added for power noise reduction. Use one with an equivalent impedance (600Ω at 100MHz; IDC 200mA).
2. Place C1, C2 and C5 bypass-capacitors as close as possible to the module.
3. Damping resistors R1 and R2 can be modified based on system application for EMI.
4. Pull high resistors, R3 and R4, can be modified based on system application for I²C.
5. The default of Pull-low resistor R7 is set at a low level for the WAKE UP pin to function.

Reference Schematic Design for the SPI Bus

[UART+SPI Application](#) provides a schematic reference design for the SPI bus:

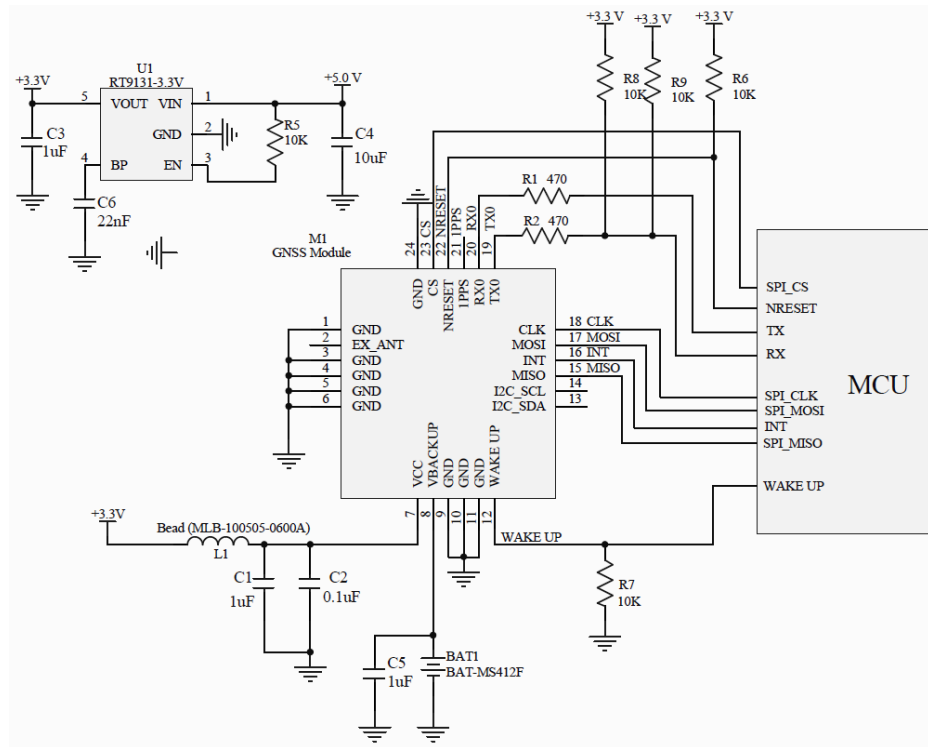

Figure 4-3: UART+SPI Application

Notes:

1. Ferrite bead L1 is added for power noise reduction. Use one with an equivalent impedance (600Ω at 100MHz; IDC 200mA).
2. Place C1, C2 and C5 bypass-capacitors as close as possible to the module.
3. Damping resistors R1 and R2 can be modified to manage EMI for system application.
4. The default of Pull-low resistor R7 is set at a low level for the WAKE UP pin to function.

Reference Schematic Design for Using an Active Antenna

Please connect the external antenna to EX_ANT (Pin2)

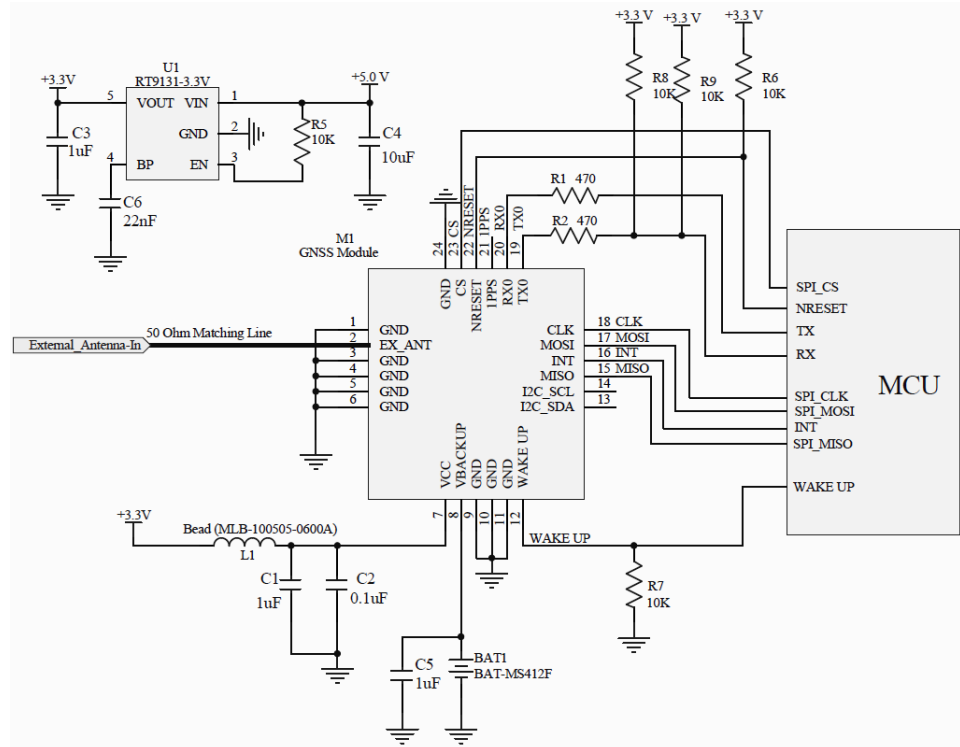

Figure 4-4: Active Antenna Application

Notes:

1. Ferrite bead L1 is added for power noise reduction. Use one with an equivalent impedance (600Ω at 100MHz; IDC 200mA).
2. Place C1, C2 and C5 bypass-capacitors as close as possible to the module.
3. Damping resistors R1 and R2 can be modified to manage EMI for system application.
4. The default of Pull-low resistor R7 is set at a low level for the WAKE UP pin to function.