

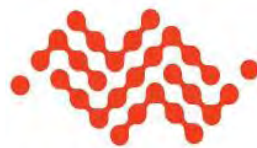

AT Command Manual for Firmware L30

AirPrime WS6318



SIERRA
WIRELESS

4111702
6.0
June 22, 2012

Important Notice

Due to the nature of wireless communications, transmission and reception of data can never be guaranteed. Data may be delayed, corrupted (i.e., have errors) or be totally lost. Although significant delays or losses of data are rare when wireless devices such as the Sierra Wireless modem are used in a normal manner with a well-constructed network, the Sierra Wireless modem should not be used in situations where failure to transmit or receive data could result in damage of any kind to the user or any other party, including but not limited to personal injury, death, or loss of property. Sierra Wireless accepts no responsibility for damages of any kind resulting from delays or errors in data transmitted or received using the Sierra Wireless modem, or for failure of the Sierra Wireless modem to transmit or receive such data.

Safety and Hazards

Do not operate the Sierra Wireless modem in areas where cellular modems are not advised without proper device certifications. These areas include environments where cellular radio can interfere such as explosive atmospheres, medical equipment, or any other equipment which may be susceptible to any form of radio interference. The Sierra Wireless modem can transmit signals that could interfere with this equipment. Do not operate the Sierra Wireless modem in any aircraft, whether the aircraft is on the ground or in flight. In aircraft, the Sierra Wireless modem **MUST BE POWERED OFF**. When operating, the Sierra Wireless modem can transmit signals that could interfere with various onboard systems.

Note: Some airlines may permit the use of cellular phones while the aircraft is on the ground and the door is open. Sierra Wireless modems may be used at this time.

The driver or operator of any vehicle should not operate the Sierra Wireless modem while in control of a vehicle. Doing so will detract from the driver or operator's control and operation of that vehicle. In some states and provinces, operating such communications devices while in control of a vehicle is an offence.

Limitations of Liability

This manual is provided "as is". Sierra Wireless makes no warranties of any kind, either expressed or implied, including any implied warranties of merchantability, fitness for a particular purpose, or noninfringement. The recipient of the manual shall endorse all risks arising from its use.

The information in this manual is subject to change without notice and does not represent a commitment on the part of Sierra Wireless. SIERRA WIRELESS AND ITS AFFILIATES SPECIFICALLY DISCLAIM LIABILITY FOR ANY AND ALL DIRECT, INDIRECT, SPECIAL, GENERAL, INCIDENTAL, CONSEQUENTIAL, PUNITIVE OR EXEMPLARY DAMAGES INCLUDING, BUT NOT LIMITED TO, LOSS OF PROFITS OR REVENUE OR ANTICIPATED PROFITS OR REVENUE ARISING OUT OF THE USE OR INABILITY TO USE ANY SIERRA WIRELESS PRODUCT, EVEN IF SIERRA WIRELESS AND/OR ITS AFFILIATES HAS BEEN ADVISED OF THE POSSIBILITY OF SUCH DAMAGES OR THEY ARE FORESEEABLE OR FOR CLAIMS BY ANY THIRD PARTY.

Notwithstanding the foregoing, in no event shall Sierra Wireless and/or its affiliates aggregate liability arising under or in connection with the Sierra Wireless product, regardless of the number of events, occurrences, or claims giving rise to liability, be in excess of the price paid by the purchaser for the Sierra Wireless product.

Customer understands that Sierra Wireless is not providing cellular or GPS (including A-GPS) services. These services are provided by a third party and should be purchased directly by the Customer.

SPECIFIC DISCLAIMERS OF LIABILITY: CUSTOMER RECOGNIZES AND ACKNOWLEDGES SIERRA WIRELESS IS NOT RESPONSIBLE FOR AND SHALL NOT BE HELD LIABLE FOR ANY DEFECT OR DEFICIENCY OF ANY KIND OF CELLULAR OR GPS (INCLUDING A-GPS) SERVICES.

Patents

This product may contain technology developed by or for Sierra Wireless Inc.

This product includes technology licensed from QUALCOMM®.



This product is manufactured or sold by Sierra Wireless Inc. or its affiliates under one or more patents licensed from InterDigital Group.

Copyright

© 2012 Sierra Wireless. All rights reserved.

Trademarks

AirCard® is a registered trademark of Sierra Wireless. Sierra Wireless™, AirPrime™, AirLink™, AirVantage™, Watcher™ and the Sierra Wireless logo are trademarks of Sierra Wireless.

 ,  , inSIM®, WAVECOM®, WISMO®, Wireless Microprocessor®, Wireless CPU®, Open AT® are filed or registered trademarks of Sierra Wireless S.A. in France and/or in other countries.

Windows® and Windows Vista® are registered trademarks of Microsoft Corporation.

Macintosh and Mac OS are registered trademarks of Apple Inc., registered in the U.S. and other countries.

QUALCOMM® is a registered trademark of QUALCOMM Incorporated. Used under license.

Other trademarks are the property of the respective owners.

Contact Information

Sales Desk:	Phone:	1-604-232-1488
	Hours:	8:00 AM to 5:00 PM Pacific Time
	E-mail:	sales@sierrawireless.com
Post:	Sierra Wireless 13811 Wireless Way Richmond, BC Canada V6V 3A4	
Fax:	1-604-231-1109	
Web:	www.sierrawireless.com	

Consult our website for up-to-date product descriptions, documentation, application notes, firmware upgrades, troubleshooting tips, and press releases: www.sierrawireless.com

Document History

Revision	Date	Update(s)
001	November 03, 2011	Created for B30_01gg firmware
2.0	December 12, 2011	Updated for B30_02gg firmware
3.0	January 05, 2012	Updated for B30_03gg firmware
		Added: <ul style="list-style-type: none"> 8.6.27 +WDDM Downlink DTMF Detection 8.6.28 +WPOW Transmitted Power Measurement
4.0	January 30, 2012	Updated for B30_04gg firmware
		Added: <ul style="list-style-type: none"> 3.6.17 +CLVL Loudspeaker Volume 8.6.16 +WPCM Set PCM Configuration 8.6.17 +WAUDPROF Audio Profile
		Updated: <ul style="list-style-type: none"> 3.1.7 +CMUX Multiplexing Mode 3.6.3 +CPIN Enter PIN 4.2.4 &F Factory Defined Configuration 5.2.3 &W Store Active Profile 6.3 +SPEAKER Select Audio Output 6.4 +WTONE Play Single Tone 6.7 +WDGR Receive Digital Gain Selection 6.8 +WDGT Transmit Digital Gain Selection 6.9 &T Audio Test 6.10 +VIP Initialize Voice Parameter 8.6.18 +SIDET Sidetone 8.6.19 +WMECHO Echo Cancellation and Noise Reduction 8.6.26 +WAEN Set Custom Emergency Numbers
	February 08, 2012	Updated: <ul style="list-style-type: none"> 3.4.5 +WLCK Network Operator Lock 8.3.3 +PSSLEEP Power Management Control 9.4.1 Service Creation +WIPCREATE 9.4.2 Closing a Service +WIPCLOSE 9.8 Error Codes
February 15, 2012	Updated: <ul style="list-style-type: none"> 8.6.25 +WLDO Enable/Disable 2V8_LDO Pin 9.4.3 Service Option Handling +WIPOPT 	
	Added: <ul style="list-style-type: none"> 9.5.1 File Exchange +WIPFILE 	
4.1	February 21, 2012	Updated typo in 8.6.26 +WAEN Set Custom Emergency Numbers

Revision	Date	Update(s)
4.2	February 24, 2012	Updated the notes sub-section of: <ul style="list-style-type: none"> • 6.5 +VGR Receive Gain Selection • 6.6 +VGT Transmit Gain Selection • 3.6.17 +CLVL Loudspeaker Volume
4.3	February 28, 2012	Updated: <ul style="list-style-type: none"> • 6.6 +VGT Transmit Gain Selection • 8.6.15 +WMPWM PWM and Buzzer Configuration
4.4	February 29, 2012	Updated 3.4.5 +WLCK Network Operator Lock
4.5	March 01, 2012	Updated: <ul style="list-style-type: none"> • 3.4.5 +WLCK Network Operator Lock • 3.6.17 +CLVL Loudspeaker Volume • 6.5 +VGR Receive Gain Selection
5.0	April 12, 2012	Added section 3.4.21 +CCUG Closed User Group
		Updated: <ul style="list-style-type: none"> • 4.1.2 D Dial • 4.1.3 D> Direct Dialling From Phone Book
6.0	June 22, 2012	Updated: <ul style="list-style-type: none"> • 3.4.5.2 +WLCK Parameters • 8.6.19 +WMECHO Echo Cancellation and Noise Reduction



Contents

1. AT COMMANDS DESCRIPTION	14
2. 3GPP TS 27.005 COMMANDS	15
2.1. General Configuration Commands.....	15
2.1.1. +CSMS Select Messages Service	15
2.1.2. +CPMS Preferred Messages Storage.....	16
2.1.3. +CMGF Messages Format.....	16
2.2. Message Configuration Commands.....	17
2.2.1. +CSCA Service Center Address	17
2.2.2. +CSCB Select Cell Broadcast Messages Types	18
2.2.3. +CSMP Set Text Mode Parameters.....	19
2.2.4. +CSDH Show Text Mode Parameters	20
2.2.5. +CSAS Save Settings	20
2.2.6. +CRES Restore Settings	21
2.3. Message Receiving and Reading Commands.....	21
2.3.1. +CNMI New Messages Indication to TE	21
2.3.2. +CNMA New Message Acknowledgement to ME/TA	23
2.3.3. +CMGL List Messages.....	25
2.3.4. +CMGR Read Message	27
2.4. Message Sending and Writing Commands	28
2.4.1. +CMGS Send Message	28
2.4.2. +CMSS Send Message from Storage.....	30
2.4.3. +CMGW Write Message to Memory	31
2.4.4. +CMGD Delete Message	31
2.5. SMS and CBM Unsolicited Result Codes	32
2.5.1. +CMTI Received SMS Indication	32
2.5.2. +CMT Received SMS Indication	33
2.5.3. +CBM Received CBM Indication.....	34
2.5.4. +CDS Received Status Report (SR) Indication	34
2.6. +CMS ERROR Message Service Failure Result Codes.....	35
3. 3GPP TS 27.007 COMMANDS	36
3.1. General Commands	36
3.1.1. +CGMI Request Manufacturer Identification.....	36
3.1.2. +CGMM Request Model Identification	36
3.1.3. +CGMR Request Revision Identification	37
3.1.4. +CGSN Request Product Serial Number Identification	37
3.1.5. +CSCS Select TE Character Set	37
3.1.6. +CIMI Request International Mobile Subscriber Identity.....	38
3.1.7. +CMUX Multiplexing Mode	39
3.2. Call Control Commands	41
3.2.1. +CSTA Select Type of Address	41
3.2.2. +CMOD Call Mode	42

- 3.2.3. +CHUP Hang-up Call 42
- 3.2.4. +CBST Select Bearer Service Type 43
- 3.2.5. +CRLP Radio Link Protocol 44
- 3.2.6. +CR Service Reporting 45
- 3.2.7. +CEER Extended Error Report 45
- 3.2.8. +CRC Cellular Result Codes 47
- 3.2.9. +CVHU Voice Hang-up Control 47
- 3.2.10. +CSNS Single Numbering Scheme 48
- 3.3. Call Control Result Code 49
 - 3.3.1. +CR Service Reporting 49
 - 3.3.2. +CRING Ring Indication 49
- 3.4. Network Service Related Commands 50
 - 3.4.1. +CNUM Subscriber Number 50
 - 3.4.2. +CREG Network Registration 51
 - 3.4.3. +COPS Operator Selection 52
 - 3.4.4. +CLCK Facility Lock 54
 - 3.4.5. +WLCK Network Operator Lock 55
 - 3.4.6. +CPWD Change Password 57
 - 3.4.7. +CLIP Calling Line Identification Presentation 58
 - 3.4.8. +CLIR Calling Line Identification Restriction 59
 - 3.4.9. +COLP Connected Line Identification Presentation 59
 - 3.4.10. +CCFC Call Forwarding Number and Conditions 60
 - 3.4.11. +CCWA Call Waiting 62
 - 3.4.12. +CHLD Call Related Supplementary Services 63
 - 3.4.13. +CTFR Call Deflection 63
 - 3.4.14. +CUSD Unstructured Supplementary Service Data 64
 - 3.4.15. +CAOC Advice of Charge 65
 - 3.4.16. +CSSN Supplementary Service Notifications 66
 - 3.4.17. +CLCC List Current Calls 66
 - 3.4.18. +CPOL Preferred PLMN List 68
 - 3.4.19. +CPLS Selection of Preferred PLMN List 69
 - 3.4.20. +COPN Read Operator Names 70
 - 3.4.21. +CCUG Closed User Group 70
- 3.5. Network Service Related Result Codes 71
 - 3.5.1. +CREG Network Registration 71
 - 3.5.2. +CLIP Calling Line Identification Presentation 72
 - 3.5.3. +COLP Connected Line Identification Presentation 73
 - 3.5.4. +CCWA Calling Line Identification Presentation 73
 - 3.5.5. +CUSD Unstructured Supplementary Service Data 75
 - 3.5.6. +CCCM Current Call Meter 75
 - 3.5.7. +CSSI Supplementary Service Notification 76
 - 3.5.8. +CSSU Supplementary Service Notification 76
- 3.6. Control and Status Commands 77
 - 3.6.1. +CPAS Phone Activity Status 77
 - 3.6.2. +CFUN Set Phone Functionality 77
 - 3.6.3. +CPIN Enter PIN 78
 - 3.6.4. +CPWC Power Class 79

3.6.5.	+CSQ Signal Quality	80
3.6.6.	+CMEC Mobile Termination Control Mode	81
3.6.7.	+CIND Indicator Control	82
3.6.8.	+CMER Mobile Termination Event Reporting	83
3.6.9.	+CPBS Select Phonebook Memory Storage	84
3.6.10.	+CPBR Read Phonebook Entries	85
3.6.11.	+CPBF Find Phonebook Entries	87
3.6.12.	+CPBW Write Phonebook Entry	88
3.6.13.	+CCLK Clock.....	89
3.6.14.	+CSIM Generic SIM Access	89
3.6.15.	+CRSM Restricted SIM Access	90
3.6.16.	+CRSL Ringer Sound Level.....	92
3.6.17.	+CLVL Loudspeaker Volume	92
3.6.18.	+CMUT Mute Control	93
3.6.19.	+CACM Accumulated Call Meter	93
3.6.20.	+CAMM Accumulated Call Meter Maximum	94
3.6.21.	+CPUC Price per Unit and Currency Table	94
3.6.22.	+CCWE Call Meter Maximum Event.....	95
3.6.23.	+CLAN Set Language	96
3.6.24.	+CSVM Set Voice Mail Number.....	96
3.6.25.	+CRMP Ring Melody Playback.....	97
3.6.26.	+CLAC List All Available AT Commands	98
3.6.27.	+CALA Set Alarm Time.....	98
3.6.28.	+CALD Delete Alarm.....	99
3.7.	Control and Status Result Codes	100
3.7.1.	+CCWV Call Meter Warning Value	100
3.7.2.	+CIEV Indicator Event Report.....	100
3.8.	Mobile Termination Error Control	101
3.8.1.	+CMEE Report Mobile Equipment Error	101
3.9.	Mobile Termination Error Result Code	102
3.9.1.	+CME ERROR	102
3.10.	Commands for Packet Domains.....	103
3.10.1.	+CGDCONT Define PDP Context.....	103
3.10.2.	+CGQREQ Quality of Service Profile (Requested).....	105
3.10.3.	+CGQMIN Quality of Service Profile (Minimum Acceptable).....	107
3.10.4.	+CGATT PS Attach or Detach	108
3.10.5.	+CGACT PDP Context Activate or Deactivate	108
3.10.6.	+CGCMOD PDP Context Modify	109
3.10.7.	+CGDATA Enter Data State	110
3.10.8.	+CGPADDR Show PDP Address	111
3.10.9.	+CGCLASS GPRS Mobile Station Class.....	112
3.10.10.	+CGREG GPRS Network Registration Status.....	113
3.10.11.	+CGSMS Select Service for MO SMS Messages	114
3.10.12.	Request Packet Domain Service 'D'	115
3.10.13.	Request Packet Domain IP Service 'D'	115
3.10.14.	+CGEREP Packet Domain Event Reporting	116

3.11.	Packet Domains Result Codes.....	117
3.11.1.	+CGREG Registration Status	117
4.	ITU-T V25.TER COMMANDS.....	118
4.1.	Call Control.....	118
4.1.1.	A Answer.....	118
4.1.2.	D Dial.....	118
4.1.3.	D> Direct Dialling From Phone Book	119
4.1.4.	H Hang Up.....	120
4.1.5.	L Monitor Speaker Loudness	120
4.1.6.	M Monitor Speaker Mode.....	121
4.1.7.	O Online	121
4.1.8.	P Pulse Dialling	122
4.1.9.	S0 Automatic Answer.....	122
4.1.10.	S6 Pause Before Blind Dialling	122
4.1.11.	S7 Connection Completion Timeout	123
4.1.12.	S8 Comma Dial Modifier	123
4.1.13.	S10 Automatic Disconnect Delay.....	124
4.1.14.	T Tone Dialling	124
4.2.	General TA Control Commands	125
4.2.1.	A/ Repeat last command.....	125
4.2.2.	I Identification Information	125
4.2.3.	Z Reset Default Configuration.....	125
4.2.4.	&F Factory Defined Configuration.....	127
4.2.5.	+GCAP Complete Capabilities List	129
4.2.6.	+GMI Manufacturer Identification.....	130
4.2.7.	+GMM Model Identification	130
4.2.8.	+GMR Revision Identification.....	131
4.2.9.	+GSN Serial Number Identification	131
4.3.	TA-TE Interface Commands.....	131
4.3.1.	E Echo.....	131
4.3.2.	Q Result Code Suppression.....	132
4.3.3.	S3 Line Termination Character	132
4.3.4.	S4 Response Formatting Character	133
4.3.5.	S5 Line Editing Character	133
4.3.6.	V TA Response Format.....	134
4.3.7.	X Result Code Selection and Call Progress Monitoring	134
4.3.8.	&C DCD Behaviour	135
4.3.9.	&D DTR Behaviour.....	135
4.3.10.	+IPR Fixed TE Rate	136
4.3.11.	+ICF TE-TA Character Framing.....	137
4.3.12.	+IFC TE-TA Local Flow Control	137
4.4.	Result Codes	138
5.	HAYES COMMANDS.....	140
5.1.	Standard Hayes Commands	140
5.1.1.	B Communication Option	140

5.1.2.	N Negotiate Handshake	140
5.1.3.	S1 Ring Count.....	141
5.1.4.	S2 Escape Character	141
5.1.5.	S11 DTMF Dialling Speed.....	141
5.1.6.	S95 Windows XP Compatibility.....	142
5.1.7.	W Extended Result Code.....	142
5.2.	Advanced Hayes Commands.....	143
5.2.1.	&S DSR Option	143
5.2.2.	&V Configuration Profile.....	143
5.2.3.	&W Store Active Profile.....	144
6.	TIA IS-101 COMMANDS	146
6.1.	+VTS DTMF Generation.....	146
6.1.1.	Parameters.....	146
6.1.2.	Notes	146
6.2.	+VTD DTMF Duration.....	146
6.2.1.	Parameters.....	147
6.3.	+SPEAKER Select Audio Output	147
6.3.1.	Parameters.....	147
6.3.2.	Examples.....	147
6.3.3.	Notes	148
6.4.	+WTONE Play Single Tone.....	148
6.4.1.	Parameters.....	148
6.4.2.	Attenuation Values	149
6.4.3.	Examples.....	149
6.4.4.	Notes	149
6.5.	+VGR Receive Gain Selection	150
6.5.1.	Parameters.....	150
6.5.2.	Notes	150
6.6.	+VGT Transmit Gain Selection.....	150
6.6.1.	Parameters.....	151
6.6.2.	Notes	151
6.7.	+WDGR Receive Digital Gain Selection	151
6.7.1.	Parameters.....	152
6.7.2.	Gain Conversion	152
6.7.3.	Examples.....	152
6.7.4.	Notes	153
6.8.	+WDGT Transmit Digital Gain Selection	153
6.8.1.	Parameters.....	153
6.8.2.	Examples.....	154
6.8.3.	Notes	155
6.9.	&T Audio Test.....	155
6.9.1.	Parameters.....	155
6.9.2.	Examples.....	155
6.9.3.	Notes	155
6.10.	+VIP Initialize Voice Parameter	156

6.10.1.	Parameters.....	156
6.10.2.	Notes.....	156
6.11.	+WDTMF Play DTMF Tone.....	156
6.11.1.	Parameters.....	156
6.11.2.	Attenuation Values.....	157
6.11.3.	Examples.....	157
6.11.4.	Notes.....	157
7.	TIA578A COMMANDS.....	158
7.1.	General Commands.....	158
7.1.1.	+FMI Manufacturer Identification.....	158
7.1.2.	+FMM Model Identification.....	158
7.1.3.	+FMR Revision Identification.....	159
7.2.	Capabilities Identification and Control.....	159
7.2.1.	+FCLASS Model Identification.....	159
7.2.2.	+FTH HDLC Transmit.....	160
7.2.3.	+FRH HDLC Receive.....	160
7.2.4.	+FTM Facsimile Transmit.....	161
7.2.5.	+FRM Facsimile Receive.....	162
8.	PROPRIETARY AT COMMANDS.....	163
8.1.	Capabilities Identification and Control.....	163
8.1.1.	#CLS Service Class.....	163
8.2.	Flow Control Command.....	163
8.2.1.	&R RTS/CTS option.....	163
8.3.	Manufacturer Tests Command.....	164
8.3.1.	+CPOF Power off.....	164
8.3.2.	*PSSURC Supplementary Services notification.....	164
8.3.3.	+PSSLEEP Power Management Control.....	166
8.4.	SIM Toolkit Command and Result Codes.....	167
8.4.1.	*PSSTKI SIM Toolkit Interface Configuration.....	167
8.4.2.	*PSSTK SIM Toolkit Control.....	168
8.5.	CPHS Proprietary Commands.....	171
8.5.1.	*PSVMWN Voice Message Waiting Notification.....	171
8.5.2.	*PSALS Alternate Line Service.....	172
8.5.3.	*PSDCIN Diverted Call Indicator Notification.....	173
8.5.4.	*PSMBNB Mailbox Number.....	174
8.5.5.	*PSCSP Customer Service Profile.....	175
8.5.6.	+PACSP Customer Service Profile Query by ME.....	176
8.5.7.	*PSINFN Information Number.....	177
8.6.	General Purpose Proprietary Commands.....	179
8.6.1.	*PSPRAS Pin Remaining Attempt Status.....	179
8.6.2.	*PSSEAV Service Availability.....	180
8.6.3.	+PSSREP Mobile Start-Up Reporting.....	181
8.6.4.	*PSCHRU Channel Registration URC.....	182
8.6.5.	*PSUTTZ Universal Time and Time Zone.....	183

8.6.6.	*PSPNNU EONS: PNN Notification	185
8.6.7.	*PSPNNR EONS: PNN Display	185
8.6.8.	*PSAHLPLMN Read AHLPLMN	186
8.6.9.	+PSTAT Tool Detection Enable	187
8.6.10.	*PSRDBS Radio Band Settings	187
8.6.11.	*PSADC A/D Convert Info	189
8.6.12.	+PSRIC RI Behaviour	190
8.6.13.	+WMGPIO GPIO Access	191
8.6.14.	+WMGPIOCFG GPIO Configuration.....	192
8.6.15.	+WMPWM PWM and Buzzer Configuration	193
8.6.16.	+WPCM Set PCM Configuration.....	195
8.6.17.	+WAUDPROF Audio Profile.....	196
8.6.18.	+SIDET Sidetone	199
8.6.19.	+WMECHO Echo Cancellation and Noise Reduction.....	201
8.6.20.	+WSVN IMEI Software Version Number.....	204
8.6.21.	+WMSN Serial Number.....	205
8.6.22.	+WIMEI IMEI Number	206
8.6.23.	+WEXTCLK External Clocks Setting	206
8.6.24.	+WMADC ADC Voltage Setting	208
8.6.25.	+WLDO Enable/Disable 2V8_LDO Pin	209
8.6.26.	+WAEN Set Custom Emergency Numbers	210
8.6.27.	+WDDM Downlink DTMF Detection.....	213
8.6.28.	+WPOW Transmitted Power Measurement.....	215
8.7.	Call and Network Proprietary Commands	216
8.7.1.	*PSCSCN Call State Change Notification.....	216
8.7.2.	+CNAP Calling Name Presentation	219
8.7.3.	*PSFSNT Field Strength Notification	220
8.7.4.	*PSCSSC Call Successful Control.....	221
8.7.5.	*PSCCDN Call Connection and Disconnection Notification	222
8.7.6.	*PSENGI Network Information.....	224
8.7.7.	+WGPRS GPRS Multislot Class	228
9.	TCP/IP COMMANDS.....	230
9.1.	Introduction.....	230
9.1.1.	Informational Indicators.....	230
9.2.	Principles	230
9.2.1.	Sockets Identification	231
9.3.	General Configuration	232
9.3.1.	IP Stack Handling +WIPCFG	232
9.3.2.	Bearers Handling +WIPBR	237
9.4.	IP Protocol Services	242
9.4.1.	Service Creation +WIPCREATE	242
9.4.2.	Closing a Service +WIPCLOSE	248
9.4.3.	Service Option Handling +WIPOPT	250
9.5.	Data Exchange for Protocol Services.....	254
9.5.1.	File Exchange +WIPFILE.....	254
9.5.2.	Socket Data Exchange +WIPDATA	259

- 9.6. Ping Services.....268
 - 9.6.1. PING command +WIPPING268
- 9.7. Examples of Application271
 - 9.7.1. TCP Socket271
 - 9.7.2. TCP Client Socket.....273
 - 9.7.3. UDP Socket.....275
 - 9.7.4. PING.....276
 - 9.7.5. Creating a TCP Server, Spawning the Maximum TCP Sockets (for the Configured Server)277
 - 9.7.6. Creating a Server and Trying to Create a TCP Client/Server on a Reserved Index (reserved by the Server) will Fail278
 - 9.7.7. Failed Creation of a TCP Client and Failed Creation of a TCP Server with Index Range Containing a TCP Client.....279
 - 9.7.8. Creating 8 UDP Sockets, 8 TCP Clients and 4 TCP Servers280
 - 9.7.9. Trying to Create 8 UDP Sockets, 8 TCP Client Sockets and 4 TCP Server Sockets283
 - 9.7.10. Creating TCP Client and Server Sockets in the Same Module284
- 9.8. Error Codes285



1. AT Commands Description

This manual presents detailed information about the AT command set used with the AirPrime WS6318 Embedded Module.

Note: There is no SIM card auto-detect mechanism for the AirPrime WS6318 embedded module. After the SIM card has been changed, the embedded module has to be restarted in order to detect the new SIM card. If the SIM card is not detected by the embedded module, most of the AT Commands will return ERROR.

2. 3GPP TS 27.005 Commands

2.1. General Configuration Commands

2.1.1. +CSMS Select Messages Service

Description	Command	Possible Response(s)
Select messages service	+CSMS=<service>	+CSMS: <mt>, <mo>, <bm> OK +CMS ERROR: <err>
Get current service and settings	+CSMS?	+CSMS: <service>, <mt>, <mo>, <bm> OK +CMS ERROR: <err>
Get supported services	+CSMS=?	+CSMS: (list of supported <service>s) OK +CMS ERROR: <err>

2.1.1.1. Parameters

<service>	Description
0 (default)	3GPP TS 23.040 and 3GPP TS 23.041
1	3GPP TS 23.040 and 3GPP TS 23.041 (the requirement of <service> setting 1 is mentioned under corresponding command descriptions)

<mt>, <mo>, <bm>	Description
0	Type not supported
1 (default)	Type supported

2.1.1.2. Notes

<service> = 1 shall be used only on dual OS platforms i.e when TE is the only SMS client (SMS are only routed to TA in this case)

<service> = 0 shall be used by default.

The <service> parameter is automatically saved in non-volatile memory and restored to the default value by AT&F command.

2.1.2. +CPMS Preferred Messages Storage

Description	Command	Possible Response(s)
Select memory storage	+CPMS=<mem1>[, <mem2>[, <mem3>]]	+CPMS: <used1>, <total1>, <used2>, <total2>, <used3>, <total3> OK +CMS ERROR: <err>
Get current storage status	+CPMS?	+CPMS: <mem1>, <used1>, <total1>, <mem2>, <used2>, <total2>, <mem3>, <used3>, <total3> OK +CMS ERROR: <err>
Get supported storages	+CPMS=?	+CPMS: (list of supported <mem1>s), (list of supported <mem2>s), (list of supported <mem3>s) OK +CMS ERROR: <err>

2.1.2.1. Parameters

<memx>	Description
"SM"	Only "SM" storage is supported "BM", "ME", "MT", "TA", "SR" memory locations are not supported

<usedx>, <totalx>	Description
Integer type	Computed value

2.1.3. +CMGF Messages Format

Description	Command	Possible Response(s)
Select message format	+CMGF= [<mode>]	OK +CMS ERROR: <err>
Get current format	+CMGF?	+CMGF: <mode> OK
Get supported formats	+CMGF=?	+CMGF: (list of supported <mode>s) OK

2.1.3.1. Parameters

<mode>	Description
0 (default)	PDU mode
1	Text mode
Omitted	Use previous value

2.1.3.2. Notes

+CMGF parameter is automatically saved into non-volatile memory.
 The <mode> parameter is restored to default value by AT&F command.

2.2. Message Configuration Commands

2.2.1. +CSCA Service Center Address

Description	Command	Possible Response(s)
Update SMSC address	+CSCA=<sca>[,<tosca>]	OK +CMS ERROR: <err>
Get current format	+CSCA?	+CSCA: <sca>,<tosca> OK +CMS ERROR: <err>
Get supported formats	+CSCA=?	OK +CMS ERROR: <err>

2.2.1.1. Parameters

<sca>	Description
String type	SC address Address-Value

<tosca>	Description
Integer type	SC address Type-of-Address

2.2.1.2. Notes

This command reads and writes the service center address in EF-SMSP (U)SIM file.

If the SCA is not readable or empty, read command returns an empty string.

At switch on, the SCA is read on (U)SIM to have a default SCA for send and write command in text mode. (In PDU mode, SCA can be provided in PDU).

Service Center Address is reset on switch on and is read on SIM on first PC connection after switch on.

See data stored by +CSAS for default values.

2.2.2. +CSCB Select Cell Broadcast Messages Types

Description	Command	Possible Response(s)
Select CBM types	+CSCB=[<mode>[,<mids>[,<dcss>]]]	OK +CMS ERROR: <err>
Get current values	+CSCB?	+CSCB: <mode>,<mids>,<dcss> OK +CMS ERROR: <err>
Get supported modes	+CSCB=?	+CSCB: (list of supported <mode>s) OK +CMS ERROR: <err>

2.2.2.1. Parameters

<mode>	Description
0	Message types specified in <mids> and <dcss> are accepted
1	Message types specified in <mids> and <dcss> are not accepted

<mids>	Description
String type	all different possible combinations of CBM message identifiers (refer <mid> in 27.005)

<dcss>	Description
String type	all different possible combinations of CBM data coding schemes (refer <dcs> in 27.005) Default value: no DCS accepted

2.2.2.2. Notes

All the <dcss> values can be accepted or up to 5 different <dcss> values can be accepted.

Ranges are not supported for <mids> and <dcss>, i.e notation "0,1,5,320-478,922" is not allowed for <mids> and notation "0-3,5" is not allowed for <dcss> .

Up to 15 different <mids> values can be accepted.

AT+CSCB=1 means all <dcss> are accepted but this command has no effect on the list of the <mids> accepted. To modify those lists: use before the AT+CSCB=0 command to select no mid and no dcs, and after this operation, add some dcs or mid to the current lists.

AT+CSCB=0,<mids> adds the <mids> values in the <mids> current list handled by the mobile.

AT+CSCB=0,,<dcss> adds the <dcss> values in the <dcss> current list handled by the mobile.

If AT+CSCB=0,"<value>" is received while the list of <mids> is full, OK is returned and new value is not added.

AT+CSCB=1,<mids> removes the <mids> values in the <mids> current list handled by the mobile.

AT+CSCB=1,,<dcss> removes the <dcss> values in the <dcss> current list handled by the mobile.

AT+CSCB? can only display an enabled list, so <mode> = 0 is returned.

2.2.3. +CSMP Set Text Mode Parameters

Description	Command	Possible Response(s)
Select SM parameters	+CSMP=[<fo>[,<vp>[,<pid>[,<dcs>]]]]	OK +CMS ERROR: <err>
Get current values	+CSMP?	+CSMP: <fo>,<vp>,<pid>,<dcs> OK +CMS ERROR: <err>
Test if command is supported	+CSMP=?	OK +CMS ERROR: <err>

2.2.3.1. Parameters

<fo>, <vp>, <pid>, <dcs>	Description
Integer type	Refer to 27.005 for description

2.2.3.2. Notes

The enhanced validity period format (\$(EVPF)\$, see [23.040]) is not supported.

<fo> is only for SMS-DELIVER, SMS-SUBMIT or SMS-STATUS-REPORT.

See data stored by +CSAS for default values.

+CSMP parameters are automatically saved in non-volatile memory and restored to default values by AT&F command.

2.2.4. +CSDH Show Text Mode Parameters

Description	Command	Possible Response(s)
Select header presentation	+CSDH=[<show>]	OK +CMS ERROR: <err>
Get current status	+CSDH?	+CSDH: <show> OK +CMS ERROR: <err>
Get supported values	+CSDH=?	+CSDH: (list of supported <show>s) OK +CMS ERROR: <err>

2.2.4.1. Parameters

<show>	Description
0	Do not show header values
1	Show the values in result codes
Omitted	Use previous value

2.2.5. +CSAS Save Settings

Description	Command	Possible Response(s)
Save SM service settings	+CSAS=[<profile>]	OK +CMS ERROR: <err>
Get the list of available profiles	+CSAS=?	+CSAS: (list of supported <profile>s) OK +CMS ERROR: <err>

2.2.5.1. Parameters

<profile>	Description
0	Save SM service settings in profile 0
1	Save SM service settings in profile 1
Omitted	Use previous value

2.2.5.2. Notes

Parameter stored by +CSAS

Command	Parameter Name
+CSCA	<sca>
	<tosca>
+CSMP	<fo>
	<vp>
	<pid>
	<dcs>

2.2.6. +CRES Restore Settings

Description	Command	Possible Response(s)
Restore SM service settings	+CRES=[<profile>]	OK +CMS ERROR: <err>
Get the list of available profiles	+CRES=?	+CRES: (list of supported <profile>s) OK +CMS ERROR: <err>

2.2.6.1. Parameters

<profile>	Description
0	Restore SM service settings from profile 0
1	Restore SM service settings from profile 1

2.3. Message Receiving and Reading Commands

2.3.1. +CNMI New Messages Indication to TE

Description	Command	Possible Response(s)
Select procedure for received messages	+CNMI=[<mode>[,<mt>[,<bm>[,<ds>[,<bfr>]]]]]	OK +CMS ERROR: <err>

Description	Command	Possible Response(s)
Get current values	+CNMI?	+CNMI: <mode>, <mt>, <bm>, <ds>, <bfr> OK +CMS ERROR: <err>
Get supported values	+CNMI=?	+CNMI: (list of supported <mode>s), (list of supported <mt>s), (list of supported <bm>s), (list of supported <ds>s), (list of supported <bfr>s) OK +CMS ERROR: <err>

2.3.1.1. Parameters

<mode>	Description
0 (default)	Buffer unsolicited result codes in the TA. When TA result code buffer is full: <ul style="list-style-type: none"> The oldest indication is discarded and replaced with the new one when +CSMS=0 All indications are buffered when +CSMS=1
1	Discard indication and reject new received message unsolicited result codes when TA-TE link is reserved (e.g. in on-line data mode). Otherwise forward them directly to the TE. Not supported for CBM messages.
2	Buffer unsolicited result codes in the TA when TA-TE link is reserved (e.g. in on-line data mode) and flush them to the TE after reservation. Otherwise forward them directly to the TE.
3	Forward unsolicited result codes to the TE by using the following specific inband method: While TA-TE link is reserved (meaning the TE is in online data mode by CSD or GPRS call), unsolicited result codes are replaced by a break (100ms) and stored in a buffer. The unsolicited result codes buffer is flushed to the TE after reservation (after +++ is entered). If however the TE is not in online data mode, it forwards them directly to the TE.

<mt>	Description
0 (default)	No SMS-DELIVER indications are routed to the TE
1	If SMS-DELIVER is stored into ME/TA, indication of the memory location is routed to the TE using unsolicited result code: +CMTI
2	SMS-DELIVERS (except class 2 messages and messages in the message waiting indication group (store message)) are routed directly to the TE using unsolicited result code: +CMT
3	Class 3 SMS-DELIVERS are routed directly to TE using unsolicited result codes defined in <mt>=2. Messages of other data coding schemes result in indication as defined in <mt>=1

<bm>	Description
0 (default)	No CBM indications are routed to the TE
2	New CBMs are routed directly to the TE using unsolicited result code: +CBM

<ds>	Description
0 (default)	No SMS-STATUS-REPORTs are routed to the TE
1	SMS-STATUS-REPORTs are routed to the TE using unsolicited result code: +CDS

<bfr>	Description
0 (default)	TA buffer of unsolicited result codes defined within this command is flushed to the TE when <mode> 1...3 is entered (OK response shall be given before flushing the codes).
1	TA buffer of unsolicited result codes defined within this command is cleared when <mode> 1...3 is entered

2.3.1.2. Notes

TA result code buffer is in volatile memory. Messages may get lost if the power of ME/TA is switched off before codes are sent to TE. Thus, it is not recommended to use direct message routing (<mt>=2 or 3, <bm>=2 or 3, or <ds>=1) with <mode> value 0 or 2.

When +CSMS <service> is set to 0, all received SMS are automatically stored in SIM before +CMT or +CMTI URC is sent to TE whatever <mt> value.

When +CSMS <service> is set to 1, depending of it class, SMS has to be acknowledged to network thanks to +CNMA commands. Depending of <mode>, <mt> and channel status (available or reserved) URC cannot or should not be sent to TE. In these cases SMS can be automatically acknowledged or rejected without waiting +CNMA command.

“BM” storage is not supported hence +CBMI is not supported.

“SR” storage is not supported by platform hence +CDSI is not supported.

+CNMI parameters are automatically saved in non-volatile memory.

2.3.2. +CNMA New Message Acknowledgement to ME/TA

Description	Command	Possible Response(s)
Acknowledge indication	if text mode (+CMGF=1): +CNMA if PDU mode (+CMGF=0): +CNMA [=<n>[, <length>][<CR> >PDU is given<ctrl-z/ESC>]]]	OK +CME ERROR: <err>

Description	Command	Possible Response(s)
Get supported values	+CNMA=?	if PDU mode (+CMGF=0): +CNMA: (list of supported <n>s) OK if text mode (+CMGF=1): OK +CME ERROR: <err>

2.3.2.1. Parameters

<n>	Description
0	Command operates similarly as defined for the text mode
1	Send RP-ACK (or buffered result code received correctly)
2	Send RP-ERROR Acknowledgement TPDU not supported

2.3.2.2. Notes

This command is allowed only if +CSMS <service> is set to 1 and is used to acknowledge SMS received from network.

Routing of SMS-DELIVER and SMS-STATUS-REPORT to ME/TA depends on both +CSMS configuration as well as <mt> and <ds> values of +CNMI.

In PDU, acknowledgement TPDU is not supported.

The following table summarizes the SMS-DELIVER notification modes according to these parameters:

+CNMI <mt>	+CSMS <service>=0	+CSMS <service>=1
0	SMS DELIVER mode = 0	SMS DELIVER mode = 0
1	SMS DELIVER mode = 0	SMS DELIVER mode = 0
2	SMS DELIVER mode = 0	SMS DELIVER mode = 1
3	SMS DELIVER mode = 0	SMS DELIVER mode = 2

When SMS Mode = 0: SMS acknowledgement and storage are managed internally by MS whatever their class (if needed they will be stored in SIM).

When SMS-DELIVER Mode = 1: SMS with no message class, class 0, class 1, class 3 are sent to ME/TA for acknowledgement (+CNMA expected), they will not be stored in ME, it's up to TE to store them. SMS class 2 & message waiting indication group (Store or Discard) are managed internally by MS (if needed they will be stored in SIM, no +CNMA expected).

When SMS-DELIVER Mode = 2: SMS class 3 are sent to ME/TA for acknowledgement (+CNMA expected), they will not be stored in ME, it's up to TE to store them. SMS with no message class, class 0, class 1, class 2 & message in waiting group are managed internally by MS (if needed they will be stored in SIM, no +CNMA expected).

Following table summarizes the STATUS-REPORT (SR) notification modes according to +CSMS and <ds> parameters:

+CNMI <ds>	+CSMS <service>=0	+CSMS <service>=1
0	STATUS REPORT mode = 0	STATUS REPORT mode = 0
1	STATUS REPORT mode = 0	STATUS REPORT mode = 1

When STATUS-REPORT Mode = 0: MS manages SR internally.

When STATUS-REPORT Mode = 1: SR are sent to ME/TA for acknowledgement and storage.

Refer also to +CMT URC description for waiting message indication treatment.

2.3.3. +CMGL List Messages

Description	Command	Possible Response(s)
List messages with status	+CMGL [=<stat>]	if text mode (+CMGF=1), command successful: +CMGL: <index>, <stat>, <oa/da>, [<alpha>], [<scts>] [, <tooa/toda>, <length>] <CR> <LF> <data> <CR> <LF> +CMGL: <index>, <stat>, <da/oa>, [<alpha>], [<scts>] [, <tooa/toda>, <length>] <CR> <LF> <data> [...]
Get supported values	+CMGL=?	if PDU mode (+CMGF=0) and command successful: +CMGL:<index>, <stat>, [<alpha>], <length> <CR> <LF> <pdu> [<CR> <LF> +CMGL:<index>, <stat>, [<alpha>], <length> <CR> <LF> <pdu> [...]] OK otherwise: +CMS ERROR: <err>
		+CMGL: (list of supported <stat>s) OK +CMS ERROR: <err>

2.3.3.1. Parameters

<stat>	Description
0 "REC UNREAD"	Received unread message (i.e. new message)
1 "REC READ"	Received read message

<stat>	Description
2 "STO UNSENT"	Stored unsent message
3 "STO SENT"	Stored sent message
4 "ALL"	All messages

For all other parameters, refer to 27.005 §3.1 Parameter Definitions.

Other parameters are extracted from memory storage.

2.3.3.2. Notes

Only SMS-SUBMIT and/or SMS-DELIVER can be read.

SMS-COMMAND are not supported.

CBM are not stored in ME/TA memory. CBM are not saved in SIM.

Using the <alpha> parameter will return an empty string as this parameter is not supported.

2.3.4. +CMGR Read Message

Description	Command	Possible Response(s)
Read a message	+CMGR=<index>	<p>if text mode (+CMGF=1), command successful and SMS-DELIVER:</p> <pre>+CMGR: <stat>,<oa>,[<alpha>],<scts>[,<tooa>,<fo>,<pid>,<dcs>,<sca>,<tosca>,<length>]<CR><LF><data></pre> <p>OK</p> <p>if text mode (+CMGF=1), command successful and SMS-SUBMIT:</p> <pre>+CMGR: <stat>,<da>,[<alpha>][,<toda>,<fo>,<pid>,<dcs>,[<vp>],<sca>,<tosca>,<length>]<CR><LF><data></pre> <p>OK</p> <p>if PDU mode (+CMGF=0) and command successful:</p> <pre>+CMGR: <stat>,[<alpha>],<length><CR><LF><pdu></pre> <p>OK</p> <p>otherwise:</p> <pre>+CMS ERROR: <err></pre>
Test if command is supported	+CMGR=?	<p>OK</p> <pre>+CMS ERROR: <err></pre>

2.3.4.1. Parameters

<index>	Description
1..255	Message location in "SM" memory.

<stat>	Description
0 "REC UNREAD"	Received unread message (i.e. new message)
1 "REC READ"	Received read message
2 "STO UNSENT"	Stored unsent message

<stat>	Description
3 "STO SENT"	Stored sent message
4 "ALL"	All messages

For all other parameters, refer to 27.005 §3.1 Parameter Definitions.

Other parameters are extracted from memory storage.

2.3.4.2. Notes

Only SMS-SUBMIT and/or SMS-DELIVER can be read.

SMS-COMMAND are not supported.

CBM are not stored in ME/TA memory. CBM are not saved in SIM.

Using the <alpha> parameter will return an empty string as this parameter is not supported.

2.4. Message Sending and Writing Commands

2.4.1. +CMGS Send Message

Description	Command	Possible Response(s)
Send a message	if text mode (+CMGF=1): +CMGS=<da>[,<toda>]<CR> text is entered<ctrl-Z/ESC> if PDU mode (+CMGF=0): +CMGS=<length><CR>PDU is given<ctrl-Z/ESC>	if text mode (+CMGF=1) and sending successful: +CMGS: <mr>[,<scts>] OK if PDU mode (+CMGF=0) and sending successful: +CMGS: <mr>[,<ackpdu>] OK if sending fails: +CMS ERROR: <err>
Test if command is supported	+CMGS=?	OK +CMS ERROR: <err>

2.4.1.1. Parameters

For all other parameters, refer to +CMT URC description.

In text mode <scts> is not supported, in PDU mode <ackpdu> is not supported.

2.4.1.2. Notes

In text mode: entered text is sent to address <da> and all current settings (refer to sections 2.2.3 +CSMP Set Text Mode Parameters and 2.2.1 +CSCA Service Center Address) are used to construct the actual PDU in ME/TA.

In PDU mode: <length> must indicate the number of octets coded in the TP layer data unit to be given (i.e. SMSC address octets are excluded).

The TA sends a four character sequence <CR><LF><greater_than><space> (IRA 13, 10, 62, 32) after command line is terminated with <CR>; after that text can be entered or PDU can be given from TE to ME/TA.

The DCD signal shall be in ON state while text or PDU is entered.

The echoing of entered characters back from the TA is controlled by V.25ter echo command E.

In text mode, the entered text should be formatted as follows:

- if <dc> (set with +CSMP) indicates that GSM 7 bit default alphabet is used and <fo> indicates that TP-User-Data-Header-Indication is not set: ME/TA converts the entered text into the GSM 7 bit default alphabet according to rules of Annex A; backspace can be used to delete last character and carriage returns can be used (previously mentioned four character sequence shall be sent to the TE after every carriage return entered by the user);
- if <dc> indicates that 8-bit or UCS2 data coding scheme is used or <fo> indicates that TP-User-Data-Header-Indication is set: the entered text should consist of two IRA character long hexadecimal numbers which ME/TA converts into 8-bit octet (e.g. two characters 2A (IRA 50 and 65) will be converted to an octet with integer value 42).

In PDU mode:

- The PDU shall be hexadecimal format (similarly as specified for <pdu>) and given in one line; ME/TA converts this coding into the actual octets of PDU. When the length octet of the SMSC address (given in the PDU) equals zero, the SMSC address set with command Service Centre Address +CSCA is used; in this case the SMSC Type-of-Address octet shall not be present in the PDU, i.e. TPDU starts right after SMSC length octet.

Sending can be cancelled by giving <ESC> character (IRA 27).

<ctrl-Z> (IRA 26) must be used to indicate the ending of the message body or PDU.

Text length is limited to PDU max length (164).

2.4.2. +CMSS Send Message from Storage

Description	Command	Possible Response(s)
Send a message from storage	+CMSS=<index>[,<da>[,<to da>]]	if text mode (+CMGF=1) and sending successful: +CMSS: <mr>[,<scst>] OK if PDU mode (+CMGF=0) and sending successful: +CMSS: <mr>[,<ackpdu>] OK if sending fails: +CMS ERROR: <err>
Test if command is supported	+CMSS=?	OK +CMS ERROR: <err>

2.4.2.1. Parameters

<index>	Description
1..255	Message location in "SM" memory.

In text mode <scts> is not supported, in PDU mode <ackpdu> is not supported.

For all other parameters, refer to 27.005 §3.1 Parameter Definitions.

2.4.2.2. Notes

Since SMS-STATUS-REPORTs, SMS-COMMANDs and CBM are not stored in ME/TA memory, only <index>s of SMS-SUBMITs and/or SMS-DELIVERs can be used in +CMSS.

2.4.3. +CMGW Write Message to Memory

Description	Command	Possible Response(s)
Write a message	if text mode (+CMGF=1): +CMGW[=<oa/da>[,<tooa/to da>[,<stat>]]]<CR> text is entered<ctrl-Z/ESC> if PDU mode (+CMGF=0): +CMGW=<length>[,<stat>]<CR> PDU is given<ctrl-Z/ESC>	+CMGW: <index> OK +CMS ERROR: <err>
Test if command is supported	+CMGW=?	OK +CMS ERROR: <err>

2.4.3.1. Parameters

<index>	Description
1..255	Message location in "SM" memory.

For all other parameters, refer to 27.005 §3.1 Parameter Definitions.

2.4.3.2. Notes

Text length is limited to PDU max length (164).

2.4.4. +CMGD Delete Message

Description	Command	Possible Response(s)
Delete a message	+CMGD=<index>[,<delflag>]	OK +CMS ERROR: <err>
Get supported values	+CMGD=?	+CMGD: (list of supported <index>s) [,(list of supported <delflag>s)] OK +CMS ERROR: <err>

2.4.4.1. Parameters

<delflag>	Description
0 (default value)	Delete the message specified in <index>
1	Delete all read messages from preferred message storage, leaving unread messages and stored mobile originated messages (whether sent or not) untouched
2	Delete all read messages from preferred message storage and sent mobile originated messages, leaving unread messages and unsent mobile originated messages untouched
3	Delete all read messages from preferred message storage, sent and unsent mobile originated messages leaving unread messages untouched
4	Delete all messages from preferred message storage including unread messages

<index>	Description
1..255	Message location in "SM" memory.

For all other parameters, refer to 27.005 §3.1 Parameter Definitions.

2.5. SMS and CBM Unsolicited Result Codes

2.5.1. +CMTI Received SMS Indication

Description	Result Code
Receive a SMS already stored	+CMTI: <mem>,<index>

2.5.1.1. Parameters

<index>	Description
1..255	Message location in "SM" memory.

<mem>	Description
"SM"	Only "SM" storage possible for SMS

2.5.2. +CMT Received SMS Indication

Description	Result Code
Receive a SMS	if text mode (+CMGF=1): +CMT:<oa>, [<alpha>], <scts>[, <tooa>, <fo>, <pid>, <dcs>, <sca>, <tosca>], <length> <CR><LF><data> if PDU mode (+CMGF=0): +CMT: [<alpha>], <length> <CR><LF><pdu>

2.5.2.1. Parameters

For all other parameters, refer to 27.005 §3.1 Parameter Definitions.

2.5.2.2. Notes

When +CSMS <service> is set to 0, all received SMS are automatically stored in SIM before +CMT is sent to TE.

When +CSMS <service> is set to 1, depending of it class, SMS has to be acknowledged to network thanks to +CNMA commands. Depending of <mode>, <mt> of CNMI or channel status (available or reserved) URC cannot or should not be sent to TE. In these cases SMS can be automatically acknowledged or rejected without waiting +CNMA command.

When a +CMT URC is sent to TE for a SMS that has NOT been acknowledged by TA, a timer is started. If timer expires (15sec) before +CNMA command is received, SMS is rejected.

When a +CMT URC is sent to TE for a SMS that has already been acknowledged by TA a timer is started. If timer expires (15sec) before +CNMA command is received, SMS is automatically saved in SIM (this is to not to lost an already acknowledged SMS for which +CNMA has not been received in case of switch off). If CNMA is received before timer expiration OK is returned, else ERROR is returned (TE knows that SMS has been stored in SIM).

Message waiting indication:

There are 3 possible cases to receive voice mail notification:

- TP-DCS method (STORE/DISCARD message coding groups in DCS)
- TP-UDH (Special SMS indication IEI in UDH of the SM)
- CPHS method (originating address decoding)

In all cases, the ME manages messages notifications internally (update of EF VMWI CPHS file, acknowledgement...)

In case of TP-DCS method, for message waiting indication group (store message), +CMTI is sent. For message waiting indication group (discard message) +CMT URC is sent but no +CNMA command is expected.

Voice mail waiting indication status are managed by *PSVMWN command.

Using the <alpha> parameter will return an empty string as this parameter is not supported.

2.5.3. +CBM Received CBM Indication

Description	Result Code
Receive a CBM	if text mode (+CMGF=1): +CBM: <sn>, <mid>, <dc>, <page>, <pages><CR><LF><data> if PDU mode (+CMGF=0): +CBM: <length><CR><LF><pdu>

2.5.3.1. Parameters

For all other parameters, refer to 27.005 §3.1 Parameter Definitions.

2.5.4. +CDS Received Status Report (SR) Indication

Description	Result Code
Receive a CDS	if text mode (+CMGF=1): +CDS: <fo>, <mr>, <ra>, <tora>, <scts>, <dt>, <st> if PDU mode (+CMGF=0): +CDS: <length><CR><LF><pdu>

2.5.4.1. Parameters

For all other parameters, refer to 27.005 §3.1 Parameter Definitions.

2.5.4.2. Notes

When +CSMS <service> is set to 0, all received SR are automatically acknowledged before +CDS is sent to TE.

When +CSMS <service> is set to 1, SR has to be acknowledged to network thanks to +CNMA commands. Depending of <mode>, <mt> and channel status (available or reserved) URC cannot or should not be sent to TE. In these cases SR can be automatically acknowledged or rejected without waiting +CNMA command.

2.6. +CMS ERROR Message Service Failure Result Codes

Value	Description
0...127	3GPP TS 24.011 [6] clause E.2 values
128...255	3GPP TS 23.040 [3] clause 9.2.3.22 values
300	ME failure
301	SMS service of ME reserved
302	Operation not allowed
303	Operation not supported
304	Invalid PDU mode parameter
305	Invalid text mode parameter
310	(U)SIM not inserted
311	(U)SIM PIN required
312	PH-(U)SIM PIN required
313	(U)SIM failure
314	(U)SIM busy
315	(U)SIM wrong
316	(U)SIM PUK required
317	(U)SIM PIN2 required
318	(U)SIM PUK2 required
320	Memory failure
321	Invalid memory index
322	Memory full
330	SMSC address unknown
331	No network service
332	Network timeout
340	No +CNMA acknowledgement expected
500	Unknown error

3. 3GPP TS 27.007 Commands

3.1. General Commands

3.1.1. +CGMI Request Manufacturer Identification

Description	Command	Possible Response(s)
Read manufacturer Id	+CGMI	<manufacturer> OK +CME ERROR: <err>
Test if command is supported	+CGMI=?	OK

3.1.1.1. Parameters

<manufacturer>	Description
String type	Manufacturer identification (SIERRA WIRELESS MODEM)

3.1.2. +CGMM Request Model Identification

Description	Command	Possible Response(s)
Read model	+CGMM	<model> OK +CME ERROR: <err>
Test if command is supported	+CGMM=?	OK

3.1.2.1. Parameters

<model>	Description
String type	Model identification

3.1.3. +CGMR Request Revision Identification

Description	Command	Possible Response(s)
Read revision	+CGMR	<revision> OK +CME ERROR: <err>
Test if command is supported	+CGMR=?	OK

3.1.3.1. Parameters

<revision>	Description
String type	Revision identification

3.1.4. +CGSN Request Product Serial Number Identification

Description	Command	Possible Response(s)
Read SN	+CGSN	<sn> OK +CME ERROR: <err>
Test if command is supported	+CGSN=?	OK

3.1.4.1. Parameters

<sn>	Description
String type	International mobile equipment identity (IMEI) 15 digits

3.1.5. +CSCS Select TE Character Set

Description	Command	Possible Response(s)
Set charset	+CSCS [=<chset>]	OK +CME ERROR: <err>

Description	Command	Possible Response(s)
Read current charset	+CSCS?	+CSCS: <chset> OK +CME ERROR: <err>
Get supported values	+CSCS=?	+CSCS: (list of supported <chset>s) OK +CME ERROR: <err>

3.1.5.1. Parameters

<chset>	Description
"GSM"	GSM 7 bit default alphabet (3GPP TS 23.038)
"UCS2"	16-bit universal multiple-octet coded character set (ISO/IEC10646); UCS2 character strings are converted to hexadecimal numbers from 0000 to FFFF; e.g. "004100620063" equals three 16-bit characters with decimal values 65, 98 and 99
"IRA" (default value)	International reference alphabet (ITU-T T.50)

3.1.5.2. Notes

The <chset> parameter is automatically saved in non-volatile memory and restored to default value by AT&F command.

3.1.6. +CIMI Request International Mobile Subscriber Identity

Description	Command	Possible Response(s)
Read IMSI	+CIMI	<IMSI> OK +CME ERROR: <err>
Test if command is supported	+CIMI=?	OK +CME ERROR: <err>

3.1.6.1. Parameters

<IMSI>	Description
String type (without double quotes)	International Mobile Subscriber Identity (IMSI)

3.1.7. +CMUX Multiplexing Mode

Description	Command	Possible Response(s)
Activate MUX protocol	<code>+CMUX=<mode>[,<subset>[,<port_speed>[,<N1>[,<T1>[,<N2>[,<T2>[,<T3>[,<k>]]]]]]]]]</code>	OK +CME ERROR: <err>
Read current settings	<code>+CMUX?</code>	+CMUX: <mode>,[<subset>],<port_speed>,<N1>,<T1>,<N2>,<T2>,<T3>[,<k>] OK
Get supported values	<code>+CMUX=?</code>	+CMUX: (list of supported <mode>s), (list of supported <subset>s), (list of supported <port_speed>s), (list of supported <N1>s), (list of supported <T1>s), (list of supported <N2>s), (list of supported <T2>s), (list of supported <T3>s), (list of supported <k>s) OK

3.1.7.1. Parameters

<mode>	Description
0	Basic option
1	Advanced option

<subset>	Description
0 (default)	UIH frames used only
1	UI frames used only

<port_speed>	Description
1	9 600 bits/s
2	19 200 bits/s
3	38 400 bits/s
4	57 600 bits/s
5	115 200 bits/s
6	230 400 bits/s
7	460 800 bits/s
8	921 600 bits/s

<N1>	Description
1- 1540	Maximum frame size Default: 31 (64 if Advanced option is used)

<T1>	Description
1-254	Acknowledgement timer in units of ten milliseconds Default: 10 (100 ms)

<N2>	Description
0-100	Maximum number of re-transmissions Default: 3

<T2>	Description
2-255	Response timer for the multiplexer control channel in units of ten milliseconds Default: 30

<T3>	Description
1-255	Wake up response timer in seconds Default: 10

<k>	Description
1-7	window size, for Advanced operation with Error Recovery options Default: 2

3.1.7.2. Notes

Value 2 for subset parameter is not supported because CMUX is not running in error recovery mode.

Refer also to 27.010 for more information on parameters values.

MUX frames of data length larger than N1 will be discarded by the embedded module.

When the module flow control is set to software flow control, only 3 DLC can be opened up.

+CMUX parameters are automatically stored in non-volatile memory:

Parameter Name	Default Value
<mode>	0x00
<subset>	0x00
<port_speed>	0x05
<N1>	0x1F
<T1>	0x0A
<N2>	0x03
<T2>	0x1E

Parameter Name	Default Value
<T3>	0x0A
<k>	0x02

Default values are used when +CMUX parameters are left out.

+CMUX parameters are restored to default values by AT&F command.

3.2. Call Control Commands

3.2.1. +CSTA Select Type of Address

Description	Command	Possible Response(s)
Select type of address	+CSTA=[<type>]	OK +CME ERROR: <err>
Get current type	+CSTA?	+CSTA: <type> OK +CME ERROR: <err>
Get supported types	+CSTA=?	+CSTA: (list of supported <type>s) OK +CME ERROR: <err>

3.2.1.1. Parameters

<type>	Description
129 (default)	National type of address
145	International type of address
Omitted	Use previous value

3.2.1.2. Notes

The <type> parameter is automatically saved into non-volatile memory and restored to the default value by AT&F command.

3.2.2. +CMOD Call Mode

Description	Command	Possible Response(s)
Select call mode	+CMOD=[<mode>]	OK +CME ERROR: <err>
Get current type	+CMOD?	+CMOD: <mode> OK
Get supported types	+CMOD=?	+CMOD: (list of supported <mode>s) OK

3.2.2.1. Parameters

<mode>	Description
0	Single mode

3.2.2.2. Notes

This command has no effect. It is for compatibility only.

3.2.3. +CHUP Hang-up Call

Description	Command	Possible Response(s)
Hang up calls	+CHUP	OK +CME ERROR: <err>
Test if command is supported	+CHUP=?	OK +CME ERROR: <err>

3.2.3.1. Notes

+CHUP command gives an assured procedure to disconnect the call.

Refer to section 4.1.4 H Hang Up.

Since only single mode is supported, the execution of the command always disconnects active call.

3.2.4. +CBST Select Bearer Service Type

Description	Command	Possible Response(s)
Select bearer	+CBST=[<speed>[,<name>[,<ce>]]]	OK +CME ERROR: <err>
Get current bearer	+CBST?	+CBST: <speed>,<name>,<ce> OK
Get supported types	+CBST=?	+CBST: (list of supported <speed>s), (list of supported <name>s), (list of supported <ce>s)

3.2.4.1. Parameters

<speed>	Description
0	Autobauding (automatic selection of the speed; this setting is possible in case of 3.1 kHz modem and non-transparent service)
7 (default value)	9600 bps (V.32)
71	9600 bps (V.110 or X.31 flag stuffing)

<name>	Description
0 (default value)	Data circuit asynchronous (UDI or 3.1 kHz modem)
1	Data circuit synchronous (UDI or 3.1 kHz modem) (Not supported)

<ce>	Description
0	Transparent (Not supported)
1 (default value)	Non-transparent

3.2.4.2. Notes

+CBST parameters are saved into non-volatile memory by AT&W command and restored to default value by AT&F command.

3.2.5. +CRLP Radio Link Protocol

Description	Command	Possible Response(s)
Select protocol	<code>+CRLP=[<iws>[,<mws>[,<T1>][, <N2>[,<ver>[,<T4>]]]]]</code>	OK +CME ERROR: <err>
Get current RLP	<code>+CRLP?</code>	+CRLP: <iws>,<mws>,<T1>,<N2>[,<ver1>[,<T4>]] OK
Get supported types	<code>+CRLP=?</code>	+CRLP: (list of supported <iws>s), (list of supported <mws>s), (list of supported <T1>s), (list of supported <N2>s) [,<ver1> [, (list of supported <T4>s)] OK

3.2.5.1. Parameters

<iws>	Description
0..61	IWF to MS window size

<mws>	Description
0..61	MS to IWF window size

<T1>	Description
44..255	Acknowledgement timer T1

<N2>	Description
1..255	Retransmission attempts N2

<ver1>	Description
0	RLP version

<T4>	Description
7	Re-sequencing period T4 in integer format

3.2.6. +CR Service Reporting

Description	Command	Possible Response(s)
Select service reporting mode	+CR= [<mode>]	OK +CME ERROR: <err>
Get current mode	+CR?	+CR: <mode> OK
Get supported modes	+CR=?	+CR: (list of supported <mode>s) OK

3.2.6.1. Parameters

<mode>	Description
0 (default value)	Disable reporting
1	Enable reporting
Omitted	Use previous value

3.2.6.2. Notes

The <mode> parameter is automatically saved into non-volatile memory and restored to default value by AT&F command.

3.2.7. +CEER Extended Error Report

Description	Command	Possible Response(s)
Get last error report	+CEER	+CEER: <report> OK
Test if command is supported	+CEER=?	OK

3.2.7.1. Parameters

<report>	Description
String type	String "Cause Select:<cs> Cause:<c>" is returned <cs> and <c> are numbers representing the CauseSelect and Cause

CauseSelect <cs>	Cause <c>
0 (No cause)	0 (No cause)
16 (Service provider)	0 (Unknown)
	1 (Not Allowed)
	2 (No cause)
	6 (Wrong parameter)
	9 (Network access not allowed)
	20 (All call instances are used)
	21 (ACM over ACM Max)
	22 (Invalid AOC element)
	23 (SIM increase not allowed)
	24 (Switch off)
	25 (Unknown call id)
65 (Local cause)	28 (Barred)
	1 (State error)
	2 (No call entity)
	3 (Wrong TI)
	6 (DTMF buffer overflow)
	7 (Call disconnected)
	17 (No cell available)
	32 (Local rejection)
	33 (PLMN not allowed)
	34 (Emergency call not possible)
	35 (Authentication rejected)
	36 (Network rejection)
	37 (LA not allowed)
	38 (Local timeout)
39 (Server congestion)	
40 (Local data rejection)	
48 (Failed replace PDP context)	
66 (MM network cause)	See [24.008]
67 (CC network cause)	See [24.008]
69 (RP cause)	See [24.008]
71 (SIM cause)	0 (Unknown problem)
	1 (Memory problem)
	2 (File Id not found)
	6 (Increase problem)
	7 (Technical problem)
	11 (Command not allowed)
15 (SIM card out)	
73 (SM cause)	See [24.008]

3.2.8. +CRC Cellular Result Codes

Description	Command	Possible Response(s)
Select service CR mode	+CRC=[<mode>]	OK +CME ERROR: <err>
Get current mode	+CRC?	+CRC: <mode> OK
Get supported modes	+CRC=?	+CRC: (list of supported <mode>s) OK

3.2.8.1. Parameters

<mode>	Description
0 (default)	Disables extended format
1	Enables extended format
Omitted	Use previous value

3.2.8.2. Notes

+CRC parameter is automatically saved into non-volatile memory.
The <mode> parameter is restored to default value by AT&F command.

3.2.9. +CVHU Voice Hang-up Control

Description	Command	Possible Response(s)
Select service voice hang up mode	+CVHU=[<mode>]	OK +CME ERROR: <err>
Get current mode	+CVHU?	+CVHU: <mode> +CME ERROR: <err>
Get supported modes	+CVHU=?	+CVHU: (list of supported <mode>s) +CME ERROR: <err>

3.2.9.1. Parameters

<mode>	Description
0 (default value)	"Drop DTR" ignored but OK response given. ATH disconnects.
1	"Drop DTR" and ATH ignored but OK response given
2	"Drop DTR" behavior according to &D setting. ATH disconnects
Omitted	Use previous value

3.2.9.2. Notes

If the DTR signal is inactive (if DTR is not a pulse), then "Drop DTR" will not respond with "OK".

The <mode> parameter is restored to default value by AT&F command.

3.2.10. +CSNS Single Numbering Scheme

Description	Command	Possible Response(s)
Select the bearer to be used when an MT single numbering scheme call is set up.	AT+CSNS=<mode>	OK
Get current mode	AT+CSNS?	+CSNS: <mode> OK
Get supported modes	+CSNS=?	+CSNS: (list of supported <mode>s) OK

3.2.10.1. Parameters

<mode>	Bearer to be used
0	Voice
2	Fax
4	Data

3.2.10.2. Examples

Command	Possible Responses
AT+CSNS=0 Note: Force a voice call	OK
AT+CSNS? Note: Get current value	+CSNS: 0 OK
AT+CSNS=? Note: Test command	+CSNS: (0, 2, 4) OK

3.2.10.3. Notes

This command selects the bearer to be used when an MT single numbering scheme call is set up.

Once the action command executed and returned OK, the new value will be stored in non-volatile memory.

This command is available when the module has finished its initialization.

3.3. Call Control Result Code

3.3.1. +CR Service Reporting

Description	Result Code
+CR notification sent during data call connection	+CR: <serv>

3.3.1.1. Parameters

<serv>	Description
ASYNCR	Asynchronous transparent
SYNCR	Synchronous transparent
REL ASYNCR	Asynchronous non-transparent
REL SYNCR	Synchronous non-transparent
GPRS	GPRS

3.3.2. +CRING Ring Indication

Description	Result Code
Extended format for incoming call notification	+CRING: <type>

3.3.2.1. Parameters

<type>	Description
ASYNCR	Asynchronous transparent
SYNCR	Synchronous transparent
REL ASYNCR	Asynchronous non-transparent
REL SYNCR	Synchronous non-transparent
FAX	Fax
VOICE	Voice call
VOICE AUX	Proprietary value for ALS (CPHS Alternate line service) Used in case of incoming on line 2 Refer to section 8.5.2 *PSALS Alternate Line Service.

3.3.2.2. Notes

If alternate line service is activated, <type> = "VOICE" if speech call is on line 1 and "VOICE AUX" if call is on line 2.

3.4. Network Service Related Commands

3.4.1. +CNUM Subscriber Number

Description	Command	Possible Response(s)
Get MSISDNs	+CNUM	+CNUM: [<alpha1>],<number1>,<type1> [,<speed>,<service>[,<itc>]] [<CR><LF>+CNUM: [<alpha2>],<number2> >,<type2>[,<speed>,<service> [,<itc> >]] [...]] OK +CME ERROR: <err>
Test if command is supported	+CNUM =?	+CNUM: (0-1), (list of supported <type>s) OK +CME ERROR: <err>

3.4.1.1. Parameters

<alphax>	Description
String type	Alphanumeric string associated with <number>; used character set should be the one selected with +CSCS (Not supported)

<numberx>	Description
String type	Phone number

<typex>	Description
Integer type	Type of address

<speed>	Description
Integer type	Same as +CBST

<service>	Description
0	Asynchronous modem
1	Synchronous modem
2	PAD Access (asynchronous)
3	Packet Access (synchronous)
4	Voice
5	Fax

<itc>	Description
0	3,1 kHz
1	UDI

3.4.1.2. Notes

Using the <alphax> parameter will return an empty string as this parameter is not supported.

3.4.2. +CREG Network Registration

Description	Command	Possible Response(s)
Control +CREG notification	+CREG=[<n>]	OK +CME ERROR: <err>
Get current registration status	+CREG?	+CREG: <n>,<stat>[,<lac>,<ci>] OK
Get supported values	+CREG=?	+CREG: (list of supported <n>s) OK

3.4.2.1. Parameters

<n>	Description
0 (default)	Disable network registration unsolicited result code
1	Enable network registration and location information unsolicited result code +CREG: <stat>
2	Enable network registration and location information unsolicited result code +CREG: <stat>[,<lac>,<ci>]
Omitted	Use previous value

<stat>	Description
0	Not registered, MT is not currently searching a new operator to register to
1	Registered, home network
2	Not registered, but MT is currently searching a new operator to register to
3	Registration denied
4	Unknown
5	Registered, roaming

<lac>	Description
String type	Two bytes location area code in hexadecimal format (e.g. "00C3" equals 195 in decimal)

<ci>	Description
String type	Two bytes cell ID in hexadecimal format

3.4.2.2. Notes

+CREG parameter is automatically saved into non-volatile memory.

The <n> parameter is restored to default value by AT&F command.

Using the <alpha> parameter will return an empty string as this parameter is not supported.

3.4.3. +COPS Operator Selection

Description	Command	Possible Response(s)
Select operator	+COPS=[<mode>[,<format>[,<oper>[,< Act>]]]]	OK +CME ERROR: <err>
Get current mode and operator	+COPS?	+COPS: <mode>[,<format>,<oper>[,< Act>]] OK +CME ERROR: <err>

Description	Command	Possible Response(s)
Get supported values	+COPS=?	+COPS: [list of supported (<stat>, long alphanumeric <oper>, short alphanumeric <oper>, numeric <oper>[, <AcT>])s][,, (list of supported <mode>s), (list of supported <format>s)] OK +CME ERROR: <err>

3.4.3.1. Parameters

<mode>	Description
0 (default)	Automatic (<oper> field is ignored)
1	Manual (<oper> field shall be present, and <AcT> optionally)
2	Deregistration (ME will be unregistered until <mode>=0 or <mode>=1 is selected)
3	Set only <format> (for read command +COPS?), do not attempt registration/deregistration (<oper> and <AcT> fields are ignored); this value is not applicable in read command response
4	Manual/automatic (<oper> field shall be present); if manual selection fails, automatic mode (<mode>=0) is entered

<format>	Description
0 (default)	Long format alphanumeric <oper>
1	Short format alphanumeric <oper>
2	Numeric <oper>

<oper>	Description
String type	Operator name (refer to [27.007])

<AcT>	Description
0	GERAN
2	UTRAN

<stat>	Description
0	Unknown
1	Available
2	Current
3	Forbidden

3.4.3.2. Notes

When Manual/automatic operator selection is requested (<mode>=4), +COPS will return <mode>=0 or <mode>=1 depending which registration mode was successful (<mode>=4 will not be returned).

If set command is aborted, an abort of the registration ongoing is requested.

If test command is aborted, the get available PLMN procedure is aborted, and a partial list of PLMN is returned.

3.4.4. +CLCK Facility Lock

Description	Command	Possible Response(s)
Execute facility operation	+CLCK=<fac>,<mode>[,<passwd>[,<class>]]	when <mode>=2 and command successful: +CLCK: <status>[,<class1>[<CR><LF>+CLCK: <status>,<class2>[...]] OK +CME ERROR: <err>
Get supported values	+CLCK=?	+CLCK: (list of supported <fac>s) OK +CME ERROR: <err>

3.4.4.1. Parameters

<fac>	Description
PS	SIM lock facility with an 8-digit password
SC	SIM (lock SIM/UICC card) (SIM/UICC asks password in MT power-up and when this lock command is issued) Correspond to PIN1 code
AO	BAOC (Barr All Outgoing Calls)
OI	BOIC (Barr Outgoing International Calls)
OX	BOIC-exHC (Barr Outgoing International Calls except to Home Country)
AI	BAIC (Barr All Incoming Calls)
IR	BIC-Roam (Barr Incoming Calls when Roaming outside the home country)
AB	All Barring services
FD	SIM card or active application in the UICC (GSM or USIM) fixed dialling memory feature (if PIN2 authentication has not been done during the current session, PIN2 is required as <passwd>)
PN	Network Personalization Correspond to NCK code
PU	Network Subset Personalization Correspond to NSCK code This option is not supported and will return ERROR when used.

<fac>	Description
PP	Service Provider Personalization Correspond to SPCK code This option is not supported and will return ERROR when used.
AC	All incoming barring services
AG	All outgoing barring services

<mode>	Description
0	Unlock
1	Lock
2	Query status

<passwd>	Description
String type	Shall be the same as password specified for the facility from the MT user interface or with command Change Password +CPWD

<class>	Description
1	Voice (telephony)
2	Data (refers to all bearer services; with <mode>=2 this may refer only to some bearer service if TA does not support values 16, 32, 64 and 128)
4	Fax (facsimile services)
7	All

<status>	Description
0	Not active
1	Active

3.4.5. +WLCK Network Operator Lock

Description	Command	Possible Response(s)
Action command	AT+WLCK=<fac>,<passwd>,<NetId> [,<CnlType>] [,<CnlData>]	OK
Test command	AT+WLCK=?	+WLCK: (list of supported < fac >s)

3.4.5.1. Description

This command allows the ME to be locked to a specific network operator.

3.4.5.2. Parameters

<fac>: Facility to be locked	Description
"PS"	SIM lock facility with an 8-digit password (PCK)
"PN"	Network lock with an 8-digit password (NCK)

<passwd>: Password code	Description
String type, 8 characters	Password code

<NetId>	Description
IMSI for SIM lock (<fac> = "PS")	Operator in numeric format (MCC and MNC) for other locks (other <fac> values). If Network lock (<fac> = "PN") is already in use, the <NetId> entered here should be identical to the original <NetId> for Network lock.
additional CnIData for Network lock (<fac> = "PN")	If SIM lock (<fac> = "PS") is not in use, it is used as an additional CnIData for Network lock (<fac> = "PN"), and is in numeric format (MCC and MNC). If SIM lock (<fac> = "PS") is already in use, the identical <NetId> in SIM lock should be entered.

<CnIType>: Type of lock for cooperative network list	Description
0	Automatic (cooperative network list retrieved from EF-CNL SIM files)
1	Manual (cooperative network list is given in the <CnIData parameter>)

<CnIData>: Cooperative network list	Description
Hexastring type	Same format as in EF-CNL SIM files

3.4.5.3. Examples

Command	Possible Responses
AT+WLCK="PN", "12345678", 20810 Note: Activate network lock on SFR (208,10)	OK Note: Network lock activated
AT+WLCK="PS", "12345678", 208105923568974 Note: Activate SIM lock	OK Note: SIM lock activated

Command	Possible Responses
AT+WLCK="PN", "12345678", 20810, 0 Note: Activate Network lock on SFR (208, 10) using cooperative network list from SIM file EF-CNL (must be present in SIM)	OK Note: Network lock activated on SFR and cooperative network list present in SIM
AT+WLCK="PN", "12345678", 20801, 1, "02F802F FFFF02F801FFFFFF" Note: Activate Network lock on F ORANGE (208, 01) with manual cooperative network list including SFR (208, 10) and Bouygtel (208, 20)	OK Note: Network lock activated on F ORANGE (primary network), SFR and Bouygtel (cooperative networks)

3.4.5.4. Notes

All locks are unlocked using the AT+CLCK command.

After unlocking, a reset is required to enable the lock again, otherwise CME ERROR: 5 is returned.

The maximum count of cooperative network list (<CnlData>) is 9; with each cooperative network entry having 12-digits (in Hexadecimal format).

3.4.6. +CPWD Change Password

Description	Command	Possible Response(s)
Set new password	+CPWD=<fac>, <oldpwd>, <newpwd>	OK +CME ERROR: <err>
Get supported values	+CPWD =?	+CPWD: list of supported (<fac>, <pwdlength>)s OK +CME ERROR: <err>

3.4.6.1. Parameters

<fac>	Description
P2	SIM PIN2
AO or OI or OX or AI or IR or AB or SC	Refer to section 3.4.4 +CLCK Facility Lock for description

<oldpwd> <newpwd>	Description
String type	<oldpwd> shall be the same as password specified for the facility from the MT user interface or with command Change Password +CPWD and <newpwd> is the new password; maximum length of password can be determined with <pwdlength>

<pwdlength>	Description
Integer type	Maximum length of the password for the facility

3.4.7. +CLIP Calling Line Identification Presentation

Description	Command	Possible Response(s)
Control +CLIP notification	+CLIP=[<n>]	OK +CME ERROR: <err>
Get status of CLIP	+CLIP?	+CLIP: <n>, <m> OK +CME ERROR: <err>
Get supported values	+CLIP=?	+CLIP: (list of supported <n>s) OK +CME ERROR: <err>

3.4.7.1. Parameters

<n>	Description
0 (default)	Disable +CLIP notification
1	Enable +CLIP notification

<m>	Description
0	CLIP not provisioned
1	CLIP provisioned
2	Unknown (e.g. no network, etc.)

3.4.7.2. Notes

+CLIP parameter is automatically saved in non-volatile memory.

The <n> parameter is restored to default value by AT&F command.

3.4.8. +CLIR Calling Line Identification Restriction

Description	Command	Possible Response(s)
Control +CLIR	+CLIR=[<n>]	OK +CME ERROR: <err>
Get status of CLIR	+CLIR?	+CLIR: <n>, <m> OK +CME ERROR: <err>
Get supported values	+CLIR=?	+CLIR: (list of supported <n>s) OK +CME ERROR: <err>

3.4.8.1. Parameters

<n>	Description
0 (default value)	Presentation indicator is used according to the subscription of the CLIR service
1	CLIR invocation
2	CLIR suppression

<m>	Description
0	CLIR not provisioned
1	CLIR provisioned in permanent mode
2	Unknown (e.g. no network, etc.)
3	CLIR temporary mode presentation restricted
4	CLIR temporary mode presentation allowed

3.4.8.2. Notes

The <n> parameter is automatically saved into non-volatile memory and restored to default value by AT&F command.

3.4.9. +COLP Connected Line Identification Presentation

Description	Command	Possible Response(s)
Control +COLP notification	+COLP=[<n>]	OK +CME ERROR: <err>

Description	Command	Possible Response(s)
Get status of COLP	+COLP?	+COLP: <n>, <m> OK +CME ERROR: <err>
Get supported values	+COLP=?	+COLP: (list of supported <n>s) OK +CME ERROR: <err>

3.4.9.1. Parameters

<n>	Description
0	Disable +COLP notification
1	Enable +COLP notification

<m>	Description
0	COLP not provisioned
1	COLP provisioned
2	Unknown (e.g. no network, etc.)

3.4.10. +CCFC Call Forwarding Number and Conditions

Description	Command	Possible Response(s)
Control +COLP notification	+CCFC=<reason>, <mode>[, <number>[, <type>[, <class>[, <subaddr>[, <satype>[, <time>]]]]]]]	when <mode>=2 and command successful: +CCFC: <status>, <class1> [, <number>, <type>[, <subaddr>, <satype>[, <time>]]] [<CR><LF>+CCFC: <status>, <class2> [, <number>, <type>[, <subaddr>, <satype>[, <time>]]]] [...] OK +CME ERROR: <err>
Get supported values	+CCFC=?	+CCFC: (list of supported <reason>s) OK +CME ERROR: <err>

3.4.10.1. Parameters

<reason>	Description
0	Unconditional
1	Mobile busy
2	No reply
3	Not reachable
4	All call forwarding
5	All conditional call forwarding

<mode>	Description
0	Disable
1	Enable
2	Query status
3	Registration
4	Erase

<number>	Description
String type	Phone number of forwarding address in format specified by <type>

<type>	Description
Integer type	Type of address

<subaddr>	Description
String type	Subaddress of format specified by <satype>

<satype>	Description
Integer type	Type of subaddress

<class>	Description
1	Voice (telephony)
2	Data (refers to all bearer services; with <mode>=2 this may refer only to some bearer service if TA does not support values 16, 32, 64 and 128)
4	Fax (facsimile services)
7 (default)	All

<time>	Description
1..30	When "no reply" is enabled or queried, this gives the time in seconds to wait before call is forwarded Default value: 20

<status>	Description
0	Not active
1	Active

3.4.11. +CCWA Call Waiting

Description	Command	Possible Response(s)
Control call waiting	<code>+CCWA=[<n>[,<mode>[,<class>]]]</code>	When <mode>=2 and command successful: +CCWA: <status>,<class1>[<CR><LF>+CCWA: <status>,<class2> [...]] OK +CME ERROR: <err>
Get current mode	<code>+CCWA?</code>	+CCWA: <n> OK +CME ERROR: <err>
Get supported values	<code>+CCWA=?</code>	+CCWA: (list of supported <reason>s) OK +CME ERROR: <err>

3.4.11.1. Parameters

<n>	Description
0	Disable presentation of +CCWA
1	Enable presentation of +CCWA

<mode>	Description
0	Disable
1	Enable
2	Query status

<class>	Description
1	Voice (telephony)
2	Data (refers to all bearer services; with <mode>=2 this may refer only to some bearer service if TA does not support values 16, 32, 64 and 128)
4	Fax (facsimile services)
7 (default)	All

<status>	Description
0	Not active
1	Active

3.4.12. +CHLD Call Related Supplementary Services

Description	Command	Possible Response(s)
Control call related services	+CHLD=[<n>]	OK +CME ERROR: <err>
Get supported values	+CHLD=?	+CHLD: (list of supported <n>s) OK +CME ERROR: <err>

3.4.12.1. Parameters

<n>	Description
0	Releases all held calls or sets User Determined User Busy (UDUB) for a waiting call.
1	Releases all active calls (if any exist) and accepts the other (held or waiting) call.
1x	Releases a specific active call x
2	Places all active calls (if any exist) on hold and accepts the other (held or waiting) call.
2x	Places all active calls on hold except call X with which communication shall be supported.
3	Adds a held call to the conversation.
4	Connects the two calls and disconnects the subscriber from both calls (ECT)

3.4.13. +CTFR Call Deflection

Description	Command	Possible Response(s)
Deflect a MT call	+CTFR=<number>[,<type>[,<subaddr>[,<satype>]]]	OK +CME ERROR: <err>
Test if command is supported	+CTFR=?	OK +CME ERROR: <err>

3.4.13.1. Parameters

<number>	Description
String type	Phone number

<type>	Description
Integer type	Type of address

<subaddr>	Description
String type	Subaddress of format specified by <satype>

<satype>	Description
Integer type	Type of subaddress

3.4.14. +CUSD Unstructured Supplementary Service Data

Description	Command	Possible Response(s)
Control USSD	+CUSD=[<n>[,<str>[,<dcs>]]]	OK +CME ERROR: <err>
Get current mode	+CUSD?	+CUSD: <n> OK +CME ERROR: <err>
Get supported values	+CUSD=?	+CUSD: (list of supported <n>s) OK +CME ERROR: <err>

3.4.14.1. Parameters

<n>	Description
0	Disable the result code presentation to the TE
1	Enable the result code presentation to the TE
2	Cancel session (not applicable to read command response)

<str>	Description
String type	USSD-string

<dc>	Description
Integer type	Cell Broadcast Data Coding Scheme Default value: 0

3.4.14.2. Notes

When TE sends an USSD to the network, the OK result code is sent before the response of the network. When network answers, the response will be sent as an URC (as if it was a network initiated operation, in case of error +CUSD: 4 will be sent).

This allows the link not to be blocked for a long time (the network can take a long time to answer a USSD request initiated by the TE).

The USSD session can be aborted using command AT+CUSD=2.

3.4.15. +CAOC Advice of Charge

Description	Command	Possible Response(s)
Control AOC notification	+CAOC [=<mode>]	If <mode>=0: +CAOC: <ccm> OK +CME ERROR: <err>
Get current mode	+CAOC?	+CAOC: <mode> OK +CME ERROR: <err>
Get supported values	+CAOC=?	+CAOC: (list of supported <mode>s) OK +CME ERROR: <err>

3.4.15.1. Parameters

<mode>	Description
0	Query CCM value
1	Deactivate the unsolicited reporting of CCM value
2	Activate the unsolicited reporting of CCM value

<ccm>	Description
String type	Three bytes of the current call meter value in hexadecimal format (e.g. "00001E" indicates decimal value 30); value is in home units and bytes are similarly coded as ACMmax value in the SIM card or in the active application in the UICC (GSM or USIM)

3.4.16. +CSSN Supplementary Service Notifications

Description	Command	Possible Response(s)
SS notification control	+CSSN=[<n>[,<m>]]	OK +CME ERROR: <err>
Get current mode	+CSSN?	+CSSN: <n>,<m> OK
Get supported values	+CSSN=?	+CSSN: (list of supported <n>s), (list of supported <m>s) OK

3.4.16.1. Parameters

<n>	Description
0 (default)	Disable presentation of +CSSI
1	Enable presentation of +CSSI

<m>	Description
0 (default)	Disable presentation of +CSSU
1	Enable presentation of +CSSU

3.4.16.2. Notes

+CSSN parameters are automatically saved into non-volatile memory.

3.4.17. +CLCC List Current Calls

Description	Command	Possible Response(s)
SS notification control	+CLCC	[+CLCC: <id1>,<dir>,<stat>,<mode>,<mpty>[,<number>,<type>[,<alpha>]] [<CR><LF>+CLCC: <id2>,<dir>,<stat>,<mode>,<mpty>[,<number>,<type>[,<alpha>]] [...]] OK +CME ERROR: <err>
Test if command is supported	+CLCC=?	OK +CME ERROR: <err>

3.4.17.1. Parameters

<idx>	Description
1..7	Call identification number This number can be used in +CHLD command operations

<dir>	Description
0	Mobile originated (MO) call
1	Mobile terminated (MT) call

<stat>	Description
0	Active
1	Held
2	Dialing (MO call)
3	Alerting (MO call)
4	Incoming (MT call)
5	Waiting (MT call)

<mode>	Description
0	Voice
1	Data
2	Fax

<mpty>	Description
0	Call is not one of multiparty (conference) call parties
1	Call is one of multiparty (conference) call parties

<number>	Description
String type	Phone number

<type>	Description
Integer type	Type of address

<Alpha>	Description
String type	Alphanumeric representation of <number> corresponding to the entry found in phonebook; used character set should be the one selected with +CSCS (Not supported)

3.4.17.2. Notes

Using the <alpha> parameter will return an empty string as this parameter is not supported.

The <mpty> parameter gets a value of 1 during a multiparty (conference) call party and will continue to have a value of 1 even after the multiparty (conference) call party has been disconnected.

3.4.18. +CPOL Preferred PLMN List

Description	Command	Possible Response(s)
Write an entry in list of preferred PLMNs	+CPOL=[<index>] [, <format> [, <oper> [, <GSM_Act>, <GSM_Compact_Act>, <UTRAN_Act>]]]	OK +CME ERROR: <err>
List all entries	+CPOL?	+CPOL: <index1>, <format>, <oper1> [, <GSM_Act1>, <GSM_Compact_Act1>, <UTRAN_Act1>] [+CPOL: <index2>, <format>, <oper2> [, <GSM_Act2>, <GSM_Compact_Act2>, <UTRAN_Act2>] [...]] OK +CME ERROR: <err>
Get supported values	+CPOL=?	+CPOL: (list of supported <index>s), (list of supported <format>s) OK +CME ERROR: <err>

3.4.18.1. Parameters

<index>	Description
Integer type	The order number of operator in the SIM/USIM preferred operator list

<format>	Description
0	Long format alphanumeric <oper>
1	Short format alphanumeric <oper>
2	Numeric <oper>

<opern>	Description
String type	Operator name (refer to [27.007])

<GSM_Actn>	Description
0	Access technology not selected

<GSM_AcTn>	Description
1	Access technology selected

<GSM_Compact_AcTn>	Description
0	Access technology not selected
1	Access technology selected

<UTRAN_AcTn>	Description
0	Access technology not selected
1	Access technology selected

3.4.18.2. Notes

<GSM_AcT>, <GSM_Compact_AcT> and <UTRAN_AcT> appears in 27.007 Release 5.

3.4.19. +CPLS Selection of Preferred PLMN List

Description	Command	Possible Response(s)
Select the list of preferred PLMN for CPOL	+CPLS=<list>	OK +CME ERROR: <err>
Get current list	+CPLS?	+CPLS: <list> OK +CME ERROR: <err>
Get supported values	+CPLS=?	+CPLS: (list of supported <list>s) OK +CME ERROR: <err>

3.4.19.1. Parameters

<list>	Description
0	User controlled PLMN selector with Access Technology EFPLMNwAcT, if not found in the SIM/UICC then PLMN preferred list EFPLMNsel (this file is only available in SIM card or GSM application selected in UICC)
1	Operator controlled PLMN selector with Access Technology EFOPLMNwAcT

3.4.19.2. Notes

This command appears in 27.007 Release 5, but SIM files EFPLMNwAcT, EFOPLMNwAcT exists in Release 99.

The <list> parameter is automatically saved into non-volatile memory.

3.4.20. +COPN Read Operator Names

Description	Command	Possible Response(s)
Get list of operator name	+COPN	+COPN: <numeric1>,<alpha1>[<CR><LF> +COPN: <numeric2>,<alpha2>[...]] OK +CME ERROR: <err>
Test if command is supported	+COPN=?	OK +CME ERROR: <err>

3.4.20.1. Parameters

<numeric>	Description
String type	Operator in numeric format (see +COPS)

<alphan>	Description
String type	Operator in long alphanumeric format (see +COPS)

3.4.21. +CCUG Closed User Group

Description	Command	Possible Response(s)
Activate/deactivate closed user group (CUG) information for all outgoing calls	+CCUG=[<n>[,<index>[,<info>]]]	OK
List all CUGs	+CCUG?	+CCUG: <n>,<index>,<info> OK
Test if command is supported	+CCUG=?	+CCUG: (list of supported <n>s), (list of supported <index>s), (list of supported <info>s) OK

3.4.21.1. Description

This command allows control of the Closed User Group supplementary service (refer to 3GPP TS 22.085 for more information). The set command enables the served subscriber to select a CUG index, to suppress the Outgoing Access (OA), and to suppress the preferential CUG.

The set command with $\langle n \rangle = 1$ enables to control the CUG information on the air interface as a default adjustment for all following outgoing calls.

3.4.21.2. Parameters

<n>	Description
0 (default)	Disable CUG temporary mode
1	Enable CUG temporary mode

<index>	Description
0...9	CUG index Default value: 0
10	No index (preferred CUG taken from subscriber data)

<info>	Description
0 (default)	No information
1	Suppress OA
2	Suppress preferential CUG
3	Suppress OA and preferential CUG

3.4.21.3. Notes

+CCUG parameters are automatically saved into non-volatile memory.

3.5. Network Service Related Result Codes

3.5.1. +CREG Network Registration

Description	Result Code
Network registration status change event	+CREG: <stat>[,<lac>,<ci>]

3.5.1.1. Parameters

Refer to section 3.4.2 +CREG Network .

3.5.2. +CLIP Calling Line Identification Presentation

Description	Result Code
Calling Line Identification Presentation	+CLIP: <number>,<type>[,<subaddr>,<satype>[, [<alpha>] [,<CLI validity>]]]

3.5.2.1. Parameters

<number>	Description
String type	Phone number

<type>	Description
Integer type	Type of address

<subaddr>	Description
String type	Subaddress of format specified by <satype>

<satype>	Description
Integer type	Type of subaddress

<alpha>	Description
String type	Alphanumeric representation of <number> corresponding to the entry found in phonebook; used character set should be the one selected with +CSCS (Not supported)

<CLI validity>	Description
0	CLI valid
1	CLI has been withheld by the originator
2	CLI is not available due to interworking problems or limitations of originating network

3.5.2.2. Notes

Using the <alpha> parameter will return an empty string as this parameter is not supported.

3.5.3. +COLP Connected Line Identification Presentation

Description	Result Code
Connected Line Identification Presentation	+COLP: <number>, <type> [, <subaddr>, <satype> [, <alpha>]]

3.5.3.1. Parameters

<number>	Description
String type	Phone number

<type>	Description
Integer type	Type of address

<subaddr>	Description
String type	Subaddress of format specified by <satype>

<satype>	Description
Integer type	Type of subaddress

<alpha>	Description
String type	Alphanumeric representation of <number> corresponding to the entry found in phonebook; used character set should be the one selected with +CSCS (Not supported)

3.5.3.2. Notes

Using the <alpha> parameter will return an empty string as this parameter is not supported.

3.5.4. +CCWA Calling Line Identification Presentation

Description	Result Code
Call waiting notification	+CCWA: <number>, <type>, <class> [, <alpha>] [, <CLI validity> [, <subaddr>, <satype>]]

3.5.4.1. Parameters

<number>	Description
String type	Phone number

<type>	Description
Integer type	Type of address

<subaddr>	Description
String type	Subaddress of format specified by <satype>

<satype>	Description
Integer type	Type of subaddress

<alpha>	Description
String type	Alphanumeric representation of <number> corresponding to the entry found in phonebook; used character set should be the one selected with +CSCS (Not supported)

<class>	Description
1	Voice (telephony)
2	Data (refers to all bearer services; with <mode>=2 this may refer only to some bearer service if TA does not support values 16, 32, 64 and 128)
4	Fax (facsimile services)
7 (default)	All

<CLI validity>	Description
0	CLI valid
1	CLI has been withheld by the originator
2	CLI is not available due to interworking problems or limitations of originating network

3.5.4.2. Notes

Using the <alpha> parameter will return an empty string as this parameter is not supported.

3.5.5. +CUSD Unstructured Supplementary Service Data

Description	Result Code
USSD response from the network, or network initiated operation	+CUSD: <m>[,<str>,<dcs>]

3.5.5.1. Parameters

<n>	Description
0	No further user action required (network initiated USSD Notify, or no further information needed after mobile initiated operation)
1	Further user action required (network initiated USSD Request, or further information needed after mobile initiated operation)
2	USSD terminated by network
4	Operation not supported
5	Network time out

<str>	Description
String type	USSD-string

<dcs>	Description
Integer type	Cell Broadcast Data Coding Scheme Default value: 0

3.5.5.2. Notes

Refer to section 3.5.5 +CUSD Unstructured Supplementary Service .

3.5.6. +CCCM Current Call Meter

Description	Result Code
CCM value	+CCCM: <ccm>

3.5.6.1. Parameters

<ccm>	Description
String type	Three bytes of the current call meter value in hexadecimal format (e.g. "00001E" indicates decimal value 30); value is in home units and bytes are similarly coded as ACMmax value in the SIM card or in the active application in the UICC (GSM or USIM)

3.5.6.2. Notes

This unsolicited result code is sent whenever the CCM value changes, but not more than once every 10s. This URC is activated when CAOC is in mode 2.

3.5.7. +CSSI Supplementary Service Notification

Description	Result Code
SS notification for MO call	+CSSI: <code1>

3.5.7.1. Parameters

<code1>	Description
0	Unconditional call forwarding is active
1	Some of the conditional call forwardings are active
2	Call has been forwarded
3	Call is waiting
5	Outgoing calls are barred
6	Incoming calls are barred
7	CLIR suppression rejected
8	Call has been deflected

3.5.8. +CSSU Supplementary Service Notification

Description	Result Code
SS notification	+CSSU: <code2>

3.5.8.1. Parameters

<code2>	Description
0	This is a forwarded call (MT call setup)
2	Call has been put on hold (during a voice call)
3	Call has been retrieved (during a voice call)
4	Multiparty call entered (during a voice call)
5	Call on hold has been released (this is not a SS notification) (during a voice call)
7	Call is being connected (alerting) with the remote party in alerting state in explicit call transfer operation (during a voice call)
8	Call has been connected with the other remote party in explicit call transfer operation (during a voice call or MT call setup)

<code2>	Description
9	This is a deflected call (MT call setup)

3.6. Control and Status Commands

3.6.1. +CPAS Phone Activity Status

Description	Command	Possible Response(s)
Get activity status	+CPAS	+CPAS: <pas> OK +CME ERROR: <err>
Get supported values	+CPAS=?	+CPAS: (list of supported <pas>s) OK +CME ERROR: <err>

3.6.1.1. Parameters

<pas>	Description
0	Ready (MT allows commands from TA/TE)
2	Unknown (MT is not guaranteed to respond to instructions)
3	Ringing (MT is ready for commands from TA/TE, but the ringer is active)
4	Call in progress (MT is ready for commands from TA/TE, but a call is in progress)

3.6.2. +CFUN Set Phone Functionality

Description	Command	Possible Response(s)
Select the level of functionality	+CFUN=[<fun>[,<rst>]]	OK +CME ERROR: <err>
Get current level	+CFUN?	+CFUN: <fun> OK +CME ERROR: <err>
Get supported values	+CFUN=?	+CFUN: (list of supported <fun>s), (list of supported <rst>s) OK +CME ERROR: <err>

3.6.2.1. Parameters

<fun>	Description
1 (default)	Full functionality
4	Disable phone both transmit and receive RF circuits
Omitted	Use previous value

<rst>	Description
0 (default)	Do not reset the MT before setting it to <fun> power level
1	Reset the MT before setting it to <fun> power level

3.6.2.2. Notes

AT+CFUN=1,1 resets the mobile. "OK" result code will appear after reset has been completed.

AT+CFUN=1,1 has no effect on radio on/off, it leaves it as the same state it was before reset.

AT+CFUN=1,0 requests a radio on and memorize in non-volatile memory <fun> level.

AT+CFUN=4,0 requests a radio off and memorize in non-volatile memory <fun> level.

At next switch on, ME will start with the <fun> level of the last +CFUN (i.e radio on or off). This allows TE to have control on radio on/off.

+CFUN parameter is automatically saved into non-volatile memory.

The <fun> parameter is restored to default value by AT&F. Note that the module has to be restarted to restore the default value. For example, if the current value of +CFUN=4 and AT&F is used to restore it to default value, although +CFUN: 1 is displayed, the radio will not be turned ON until the module is restarted.

3.6.3. +CPIN Enter PIN

Description	Command	Possible Response(s)
Send password to MT	+CPIN=<pin>[,<newpin>]	OK +CME ERROR: <err>
Check if a password is expected	+CPIN?	+CPIN: <code> +CME ERROR: <err>
Test if command is supported	+CPIN=?	OK +CME ERROR: <err>

3.6.3.1. Parameters

<code>	Description
READY	MT is not pending for any password

<code>	Description
SIM PIN	MT is waiting SIM PIN to be given
SIM PUK	MT is waiting SIM PUK to be given
SIM PIN2	MT is waiting SIM PIN2 to be given This <code> is returned only when the last executed command resulted in PIN2 authentication failure (i.e. +CME ERROR: 17). If PIN2 is not entered right after the failure, MT does not block its operation
SIM PUK2	MT is waiting SIM PUK2 to be given This <code> is returned only when the last executed command resulted in PUK2 authentication failure (i.e. +CME ERROR: 18). If PUK2 and new PIN2 are not entered right after the failure, MT does not block its operation
PH-NET PIN	MT is waiting network personalization password to be given Correspond to NCK code
PH-NETSUB PIN	MT is waiting network subset personalization password to be given Correspond to NSCK code
PH-SP PIN	MT is waiting service provider personalization password to be given Correspond to SPCK code
PH-CORP PIN	MT is waiting corporate personalization password to be given Correspond to CCK code

3.6.3.2. Notes

When the pin code is required, the error result code is a CMS ERROR for the AT commands that belong to the 27.005 and a CME ERROR for all the other AT commands.

3.6.4. +CPWC Power Class

Description	Command	Possible Response(s)
Set power class for corresponding band	+CPWC=[<class>[,<band>]]	OK +CME ERROR: <err>
Get the list of current and default power class for each supported band	+CPWC?	+CPWC: <curr_class1>,<def_class1>,<band1> [,<curr_class2>,<def_class2>,<band2> [...]] OK +CME ERROR: <err>
Get supported values	+CPWC=?	+CPWC: list of supported (<band>,(list of <class>s pair)) OK +CME ERROR: <err>

3.6.4.1. Parameters

<class> <curr_classn> <def_classn>	Description
Integer type	0 default (not applicable to <curr_class> or <def_classn>) 1...x MT output power class as in GSM 45.005 [38]

<band> <bandn>	Description
Integer type	Frequency band, one of the following: 0 GSM 900 1 DCS 1800 2 PCS 1900

3.6.4.2. Notes

Action command is effective after a reset.

3.6.5. +CSQ Signal Quality

Description	Command	Possible Response(s)
Get signal information	+CSQ	+CSQ: <rssi>,<ber> OK
Get supported values	+CSQ=?	+CSQ: (list of supported <rssi>s), (list of supported <ber>s) OK

3.6.5.1. Parameters

<rssi>	Description
0..31	From -113 dBm or less to -51 dBm or greater
99	Not known or not detectable

<ber>	Description
0..7	As RXQUAL values in the table in TS 45.008 [20] subclause 8.2.4
99	Not known or not detectable

3.6.5.2. Notes

The <ber> is provided only in online mode.

3.6.6. +CMEC Mobile Termination Control Mode

Description	Command	Possible Response(s)
Select equipment	+CMEC=[<keyp>[,<disp>[,<ind>]]]	OK +CME ERROR: <err>
Get current settings	+CMEC?	+CMEC: <keyp>,<disp>,<ind> OK +CME ERROR: <err>
Get supported values	+CMEC=?	+CMEC: (list of supported <keyp>s), (list of supported <disp>s), (list of supported <ind>s) OK +CME ERROR: <err>

3.6.6.1. Parameters

<keyp>	Description
0	MT can be operated only through its keypad. Not relevant on the WS6318; do not use.

<disp>	Description
0	Only MT can write to its display. Not relevant on the WS6318; do not use.

<ind>	Description
0	Only MT can set the status of its indicators (command +CIND can only be used to read the indicators)

3.6.7. +CIND Indicator Control

Description	Command	Possible Response(s)
Set MT indicators	+CIND=[<ind>[,<ind>[,...]]]	OK +CME ERROR: <err>
Get MT indicator status	+CIND?	+CIND: <ind>[,<ind>[...]] OK +CME ERROR: <err>
Get supported values	+CIND=?	+CIND: (<descr>, (list of supported <ind>s)) [, (<descr>, (list of supported <ind>s)) [...]] OK +CME ERROR: <err>

3.6.7.1. Parameters

<ind>	Description
Integer type	Range of corresponding <descr>

<descr>	Description
"battchg"	Battery charge level (0-5)
"signal"	Signal quality (0-5)
"service"	Service availability (0-1)
"message"	Message received (0-1)
"call"	Call in progress (0-1)
"roam"	Roaming indicator (0-1)
"smsfull"	A short message memory storage in the MT has become full (1), or memory locations are available (0)

3.6.7.2. Restriction

It is impossible to set indicators value.

3.6.8. +CMER Mobile Termination Event Reporting

Description	Command	Possible Response(s)
Control URC notifications	+CMER=[<mode>[,<keyp>[,<disp>[,<ind>[,<bfr>]]]]]	OK +CME ERROR: <err>
Get current settings	+CMER?	+CMER: <mode>,<keyp>,<disp>,<ind>,<bfr> OK
Get supported values	+CMER=?	+CMER: (list of supported <mode>s), (list of supported <keyp>s), (list of supported <disp>s), (list of supported <ind>s), (list of supported <bfr>s) OK

3.6.8.1. Parameters

<mode>	Description
0	Buffer unsolicited result codes in the TA; if TA result code buffer is full, codes can be buffered in some other place or the oldest ones can be discarded
1	Discard unsolicited result codes when TA TE link is reserved (e.g. in on line data mode); otherwise forward them directly to the TE
Omitted	Use previous value

<keyp>	Description
0	No keypad event reporting

<disp>	Description
0	No display event reporting

<ind>	Description
0 (default)	No indicator event reporting
1	Indicator event reporting using result code +CIEV: <ind>,<value>. <ind> indicates the indicator order number (as specified for +CIND) and <value> is the new value of indicator.
2	Indicator event reporting using result code +CIEV: <ind>,<value>. All indicator events shall be directed from TA to TE

<bfr>	Description
0	TA buffer of unsolicited result codes defined within this command is cleared when <mode> 1...3 is entered

3.6.9. +CPBS Select Phonebook Memory Storage

Description	Command	Possible Response(s)
Select phonebook memory storage	+CPBS=<storage>	OK +CME ERROR: <err>
Get current memory storage status	+CPBS?	+CPBS: <storage>[,<used>,<total>] OK +CME ERROR: <err>
Get supported storages	+CPBS=?	+CPBS: (list of supported <storage>s) OK

3.6.9.1. Parameters

<storage>	Description
DC	MT dialled calls list (+CPBW is not applicable for this storage)
EN	SIM/USIM (or MT) emergency number (+CPBW is not applicable for this storage)
FD	SIM/USIM fixed dialling phonebook. If a SIM card is present or if a UICC with an active GSM application is present, the information in EFFDN under DFTelecom is selected. If a UICC with an active USIM application is present, the information in EFFDN under ADFUSIM is selected.
MC	MT missed (unanswered received) calls list (+CPBW is not applicable for this storage)
ON	SIM (or MT) own numbers (MSISDNs) list (reading of this storage may be available through +CNUM also). When storing information in the SIM/UICC, if a SIM card is present or if a UICC with an active GSM application is present, the information in EFMSISDN under DFTelecom is selected. If a UICC with an active USIM application is present, the information in EFMSISDN under ADFUSIM is selected.
RC	MT received calls list (+CPBW is not applicable for this storage)
SM (default)	SIM/UICC phonebook. If a SIM card is present or if a UICC with an active GSM application is present, the EFADN under DFTelecom is selected. If a UICC with an active USIM application is present, the global phonebook, DFPHONEBOOK under DFTelecom is selected.
AP	Selected application phonebook. If a UICC with an active USIM application is present, the application phonebook, DFPHONEBOOK under ADFUSIM is selected

<used>	Description
Integer type	Value indicating the number of used locations in selected memory

<total>	Description
Integer type	Value indicating the total number of locations in selected memory

3.6.9.2. Notes

"SM" corresponds to SIM/UICC phonebook (global phonebook). If a SIM card is present or if a UICC with an active GSM application is present, the EFADN under DFTelecom is selected. If a UICC with an active USIM application is present, the global phonebook, DFPHONEBOOK under DFTelecom is selected.

"AP" corresponds to selected application phonebook (local phonebook). If a UICC with an active USIM application is present, the application phonebook, DFPHONEBOOK under ADFUSIM is selected.

When "FD" is selected as <storage>, the SIM PIN2 request is displayed and the request to change <storage> is disregarded. "FD" must be selected as <storage> again after SIM PIN2 has been entered to change <storage>.

+CPBS parameter is automatically saved into non-volatile memory.

The <storage> parameter is restored to default value by AT&F command.

3.6.10. +CPBR Read Phonebook Entries

Description	Command	Possible Response(s)
Read entries	+CPBR=<index1>[,<index2>]]	[+CPBR: <index1>,<number>,<type>,<text>[,<hidden>][,<group>][,<adnumber>][,<adtype>][,<secondtext>][,<email>]] [[...]] <CR><LF>+CPBR:<index2>,<number>,<type>,<text>[,<hidden>][,<group>][,<adnumber>][,<adtype>][,<secondtext>][,<email>]]] OK +CME ERROR: <err>
Get location ranges	+CPBR=?	+CPBR: (list of supported<index>s) [,<nlength>][,<tlength>][,<glength>][,<slength>][,<elength>] OK +CME ERROR: <err>

3.6.10.1. Parameters

<indexn>	Description
Integer type	Values in the range of location numbers of phonebook memory

<number>	Description
String type	Phone number of format <type>

<type>	Description
Integer type	Type of address

<text>	Description
String type	Field of maximum length <tlength> Character set as specified by +CSCS

<hidden>	Description
0	Phonebook entry not hidden
1	Phonebook entry hidden

<group>	Description
String type	Field of maximum length <glength> Character set as specified by +CSCS

<adnumber>	Description
String type	Field of maximum length <slength> Character set as specified by +CSCS

<adtype>	Description
Integer type	Type of address

<secondtext>	Description
String type	Field of maximum length <slength> Character set as specified by +CSCS

<email>	Description
String type	Field of maximum length <elength> Character set as specified by +CSCS

<nlength>	Description
Integer type	Value indicating the maximum length of field <number>

<tlength>	Description
Integer type	Value indicating the maximum length of field <text>

<glength>	Description
Integer type	Value indicating the maximum length of field <group>

<slength>	Description
Integer type	Value indicating the maximum length of field <secondtext>

<elength>	Description
Integer type	Value indicating the maximum length of field <email>

<oper>	Description
String type	Refer to [27.007]

3.6.10.2. Notes

Only first <group>,<adnumber>,<adtype>,<secondtext>,<email> are returned with the command.

3.6.11. +CPBF Find Phonebook Entries

Description	Command	Possible Response(s)
Find entries	+CPBF=<findtext>	[+CPBF: <index1>,<number>,<type>,<text>[,<hidden>][, <group>][, <adnumber>][, <adtype>][, <secondtext>][, <email>]] [[...]] <CR><LF>+CPBF:<index2>,<number>,<type>,<text> [, <hidden>][, <group>][, <adnumber>][, <adtype>][, <secondtext>][, <email>]]] OK +CME ERROR: <err>
Get location ranges	+CPBR=?	+CPBF: [<nlength>][, <tlength>][, <glength>][, <slength>][, <elength>] OK +CME ERROR: <err>

3.6.11.1. Parameters

<findtext>	Description
String type	Field of maximum length <tlength> Character set as specified by +CSCS

For other parameters: refer to section 3.6.10 +CPBR Read Phonebook .

3.6.11.2. Notes

Only first <group>, <adnumber>, <adtype>, <secondtext>, <email> are returned with the command.

3.6.12. +CPBW Write Phonebook Entry

Description	Command	Possible Response(s)
Write entry	+CPBW=<index>[, <number>[, <type>[, <text>[, <group> [, <adnumber>[, <adtype>[, <secondtext>[, <email>[, < hidden>]]]]]]]]	OK +CME ERROR: <err>
Get location ranges and supported values	+CPBW=?	+CPBW: (list of supported <index>s), [<nlength>], (list of supported <type>s), [<tlength>], [<glength>], [<slength> <elength>] OK +CME ERROR: <err>

3.6.12.1. Parameters

<index>	Description
0..999	Field of maximum length <tlength> Character set as specified by +CSCS

For other parameters: refer to section 3.6.10 +CPBR Read Phonebook .

3.6.12.2. Notes

Only first <group>, <adnumber>, <adtype>, <secondtext>, <email> are returned with the command.

If only <index> is provided, then the phone book entry located at <index> location will be deleted.

3.6.13. +CCLK Clock

Description	Command	Possible Response(s)
Set time	+CCLK=<time>	OK +CME ERROR: <err>
Get current time	+CCLK?	+CCLK: <time> OK
Test if command is supported	+CCLK=?	OK

3.6.13.1. Parameters

<time>	Description
String type	Format is "yy/mm/dd,hh:mm:ss±zz", where characters indicate year (two last digits), month, day, hours, minutes, seconds and time zone (indicates the difference, expressed in quarters of an hour, between the local time and GMT; range 47...+48). E.g. 6th of May 1994, 22:10:00 GMT+2 hours equals to "94/05/06,22:10:00+08"

3.6.14. +CSIM Generic SIM Access

Description	Command	Possible Response(s)
Send command to SIM	+CSIM=<length>,<command>	+CSIM: <length>,<response> OK +CME ERROR: <err>
Test if command is supported	+CSIM=?	OK +CME ERROR: <err>

3.6.14.1. Parameters

<length>	Description
Integer type	Length of the characters that are sent to TE in <command> or <response> (two times the actual length of the command or response)

<command>	Description
String type	Command passed on by the MT to the SIM in the format as described in GSM 51.01 Hexadecimal character format

<response>	Description
String type	Response to the command passed on by the SIM to the MT in the format as described in GSM 51.011 Hexadecimal character format

3.6.14.2. Notes

To comply with AT&T test cases, the current implementation only supports AT+CSIM=10, "A0F200002". All other SIM commands are not supported.

3.6.15. +CRSM Restricted SIM Access

Description	Command	Possible Response(s)
Send command to SIM	+CRSM=<command>[,<fileid>] > [,<P1>,<P2>,<P3>[,<data>]]	+CRSM: <sw1>,<sw2>[,<response>] OK +CME ERROR: <err>
Test if command is supported	+CRSM=?	OK

3.6.15.1. Parameters

<command>	Description
176 (READ BINARY)	Read a transparent EF Transparent file greater than 256 bytes are not supported: →P1 shall always be 0 (ERROR otherwise) →P2 shall be in the range 0-256
178 (READ RECORD)	Read a record Only P2="04" (absolute mode) is supported (Other parameters are not useful).
192 (GET RESPONSE)	Get response If <fileid> is not provided, the command applies to the last selected file
214 (UPDATE BINARY)	Read a transparent EF Only P1="00" and P2="00" is supported
220 (UPDATE RECORD)	Update a record Only P2="03" (previous mode) is allowed for updates on cyclic file (refer to [51.011]). For linear files, only P2="04" (absolute mode) is supported
242 (STATUS)	Status If <fileid> is not provided, the command applies to the last selected file

<fileid>	Description
Integer type	Identifier of an elementary data file on SIM. Mandatory for every command except STATUS

<P1> <P2> <P3>	Description
Integer type	Parameters passed on by the MT to the SIM. These parameters are mandatory for every command, except GET RESPONSE and STATUS
<data>	Description
String type	Information which shall be written to the SIM Hexadecimal character format
<sw1> <sw2>	Description
Integer type	Information from the SIM about the execution of the actual command. These parameters are delivered to the TE in both cases, on successful or failed execution of the command
<response>	Description
String type	Response of a successful completion of the command previously issued. STATUS and GET RESPONSE return data, which gives information about the current elementary data field. After READ BINARY, READ RECORD command the requested data will be returned. <response> is not returned after a successful UPDATE BINARY, UPDATE RECORD or SET DATA command Hexadecimal character format

3.6.15.2. Notes

Example:

AT+CRSM can be used to read the SIM card CCID:

```

AT+CRSM=176,12258,0,0,10
+CRSM: 144,0,"980136010000006076F5"
OK
    
```

Based on the returned response, the SIM card CCID is 891063100000006675.

The CCID was derived from the command response "980136010000006076F5" by swapping the quartets two by two. That is, 9801 is read as 8910, 3601 is read as 6310 and so on. Note that for the last quartet, 76F5, the first digit of the second pair must be discarded. So 76F5 must be read as 675.

3.6.16. +CRSL Ringer Sound Level

Description	Command	Possible Response(s)
Set incoming call ringer sound level	+CRSL=<level>	OK +CME ERROR: <err>
Get current level	+CRSL?	+CRSL: <level> OK +CME ERROR: <err>
Get supported values	+CRSL=?	+CRSL: (list of supported <level>s) OK +CME ERROR: <err>

3.6.16.1. Parameters

<level>	Description
0..3	Level range

3.6.16.2. Notes

The <level> parameter is automatically saved into non-volatile memory.

3.6.17. +CLVL Loudspeaker Volume

Description	Command	Possible Response(s)
Set sound speaker level	+CLVL=<level>	OK +CME ERROR: <err>
Get current level	+CLVL?	+CLVL: <level> OK
Get supported values	+CLVL=?	+CLVL: (list of supported <level>s) OK +CME ERROR: <err>

3.6.17.1. Parameters

<level>	Description
1..10	Level range

3.6.17.2. Notes

- +CLVL parameter is automatically saved into non-volatile memory.
- +CLVL Loudspeaker volume level setting takes effect after reset or during a voice call.
- +CLVL has no effect on the PCM bus.

3.6.18. +CMUT Mute Control

Description	Command	Possible Response(s)
Mute/unmute call	+CMUT=<n>	OK +CME ERROR: <err>
Get current mode	+CMUT?	+CMUT: <n> OK +CME ERROR: <err>
Get supported values	+CMUT=?	+CMUT: (list of supported <n>s) OK

3.6.18.1. Parameters

<n>	Description
0	Mute off
1	Mute on

3.6.19. +CACM Accumulated Call Meter

Description	Command	Possible Response(s)
Reset ACM	+CACM=[<passwd>]	OK +CME ERROR: <err>
Get current ACM	+CACM?	+CACM: <acm> OK +CME ERROR: <err>
Test if command is supported	+CACM=?	OK +CME ERROR: <err>

3.6.19.1. Parameters

<passwd>	Description
String type	SIM PIN2

<acm>	Description
String type	Accumulated call meter value similarly coded as <ccm> under +CAOC

3.6.20. +CAMM Accumulated Call Meter Maximum

Description	Command	Possible Response(s)
Set ACMmax	+CAMM=[<acmmax> [, <passwd >]]	OK +CME ERROR: <err>
Get current ACMmax	+CAMM?	+CAMM: <acm> OK +CME ERROR: <err>
Test if command is supported	+CAMM=?	OK +CME ERROR: <err>

3.6.20.1. Parameters

<acmmax>	Description
String type	Accumulated call meter maximum value similarly coded as <ccm> under +CAOC; value zero disables ACMmax feature

<passwd>	Description
String type	SIM PIN2

3.6.21. +CPUC Price per Unit and Currency Table

Description	Command	Possible Response(s)
Set price per unit and currency	+CPUC=<currency> , <ppu> [, <passwd>]	OK +CME ERROR: <err>

Description	Command	Possible Response(s)
Get current currency and price per unit	+CPUC?	+CPUC: <currency>,<ppu> OK +CME ERROR: <err>
Test if command is supported	+CPUC=?	OK +CME ERROR: <err>

3.6.21.1. Parameters

<currency>	Description
String type	Three-character currency code (e.g. "GBP", "DEM"); character set as specified by command +CSCS

<ppu>	Description
String type	Price per unit; dot is used as a decimal separator (e.g. "2.66")

<passwd>	Description
String type	SIM PIN2

3.6.22. +CCWE Call Meter Maximum Event

Description	Command	Possible Response(s)
Set call meter mode max event	+CCWE=<mode>	OK +CME ERROR: <err>
Get current mode	+CCWE?	+CCWE: <mode> OK +CME ERROR: <err>
Get supported modes	+CCWE=?	+CCWE: (list of supported <mode>s) OK +CME ERROR: <err>

3.6.22.1. Parameters

<mode>	Description
0	Disable the call meter warning event +CCWV

<mode>	Description
1	Enable the call meter warning event +CCWV

3.6.23. +CLAN Set Language

Description	Command	Possible Response(s)
Set language	+CLAN=<code>	OK +CME ERROR: <err>
Get current mode	+CLAN?	+CLAN: <code> OK +CME ERROR: <err>
Get supported modes	+CLAN=?	+CLAN: (list of supported <code>s) OK +CME ERROR: <err>

3.6.23.1. Parameters

<code>	Description
String type	Language coded in ISO 639 format. "AUTO" or 2 double quoted letters. For example "en" for English.

3.6.24. +CSVM Set Voice Mail Number

Description	Command	Possible Response(s)
Set voice mailbox number	+CSVM=<mode> [, <number> [, <type>]]	OK +CME ERROR: <err>
Get current voice mailbox number	+CSVM?	+CSVM: <mode> , <number> , <type> OK +CME ERROR: <err>
Get supported values	+CSVM=?	+CSVM: (list of supported mode>s) , (list of supported <type>s) OK +CME ERROR: <err>

3.6.24.1. Parameters

<mode>	Description
0	Disable the voice mail number i.e delete the voice mailbox number
1	Enable the voice mail number

<number>	Description
String type	Character string 0..9,+

<type>	Description
Integer type	Type of address (129 or 145)

3.6.24.2. Notes

+CSVM parameters are automatically saved into non-volatile memory.

3.6.25. +CRMP Ring Melody Playback

Description	Command	Possible Response(s)
Play ring melody	+CRMP=<calltype>[,<volume>[,<type>,<index>]]	OK +CME ERROR: <err>
Get supported values	+CRMP=?	+CRMP: (list of supported <calltype>s), (list of supported <volume>s), (<type>), (list of supported <index>s) OK +CME ERROR: <err>

3.6.25.1. Parameters

<calltype>	Description
0	Manufacturer specific

<volume>	Description
1..3	Volume

<type>	Description
0	Manufacturer defined

<index>	Description
1..10	Ring melody index
11	Vibrator mode

3.6.25.2. Notes

If a melody is played, it is played for 10 seconds and stops.

3.6.26. +CLAC List All Available AT Commands

Description	Command	Possible Response(s)
List all commands	+CLAC	+CLAC:<CR><LF><AT Command1>[<CR><LF><AT Command2>[...]] OK +CME ERROR: <err>
Test if command is supported	+CLAC=?	OK +CME ERROR: <err>

3.6.27. +CALA Set Alarm Time

Description	Command	Possible Response(s)
Set alarm	+CALA=<time>[,<n>[,<recur>]]	OK +CME ERROR: <err>
Read alarm	+CALA?	[+CALA: <time>,<n1>,[<recur>] [<CR><LF>+CALA: <time>,<n2>,[<recur>] [...]]] OK +CME ERROR: <err>
Get supported values	+CALA=?	+CALA: (list of supported <time>s), (list of supported <n>s), (list of supported <recur>s) OK +CME ERROR: <err>

3.6.27.1. Parameters

<time>	Description
07/04/11,11:34:25	Internal clock (Cf. +CCLK) string type "hh:mm:ss" if <recurr> is present or "yy/mm/dd, hh:mm:ss" if not.

<n>, <n1>, <n2>	Description
1..5	Index of the alarm

<recurr>	Description
"0", "1,..,7"	String type value indicating day of week for the alarm in one of the following formats: "<1..7>[,<1..7>[...]]" – Sets a recurrent alarm for one or more days in the week. The digits 1 to 7 corresponds to the days in the week, Monday (1), ..., Sunday (7). Example: The string "1,2,3,4,5" may be used to set an alarm for all weekdays. "0" sets a recurrent alarm for all days in the week.

3.6.27.2. Notes

Set command sets an alarm time in the MT. If setting fails in an MT error, +CME ERROR: <err> is returned. To set up a recurrent alarm for one or more days in the week, the <recurr>-parameter may be used.

When an alarm is timed out and executed, the unsolicited result code +CALV: <n> is always returned. Read command returns the list of current active alarm settings in the MT. Test command returns the supported syntax.

3.6.28. +CALD Delete Alarm

Command	Possible Response(s)
+CALD=<n>	OK +CME ERROR: <err>
+CALD=?	+CALD: (list of supported <n>s) OK+CME ERROR: <err>

3.6.28.1. Parameters

<n>	Description
1..5	Integer type value indicating the index of the alarm

3.6.28.2. Notes

Action command deletes an alarm in the MT. If the command fails in an MT error, +CME ERROR: <err> is returned. Test command returns supported index values.

3.7. Control and Status Result Codes

3.7.1. +CCWV Call Meter Warning Value

Description	Result Code
Call meter warning value	+CCWV

3.7.1.1. Parameters

<ccm>	Description
String type	Three bytes of the current call meter value in hexadecimal format (e.g. "00001E" indicates decimal value 30); value is in home units and bytes are similarly coded as ACMmax value in the SIM card or in the active application in the UICC (GSM or USIM)

3.7.1.2. Notes

This warning will be triggered shortly before the ACM (Accumulated Call Meter) maximum value is reached, an unsolicited result code +CCWV will be sent, if enabled by +CCWE command. The warning is issued approximately when 30 seconds call time remains. It is also issued when starting a call if less than 30 seconds call time remains.

3.7.2. +CIEV Indicator Event Report

Description	Result Code
Event report	+CIEV: <ind>,<value>

3.7.2.1. Parameters

<ind>	Description
0	Battery charge level (0-5)
1	Signal quality (0-5)
2	Service availability (0-1)

<value>	Description
0..5	Range of value for <ind>=0
0..4	Range of value for <ind>=1

3.7.2.2. Examples

Example	Description
+CIEV: 2,0	Service is not available
+CIEV: 1,1	Signal quality equals 1
+CIEV: 30	CME Error: no network service. This error is reported when “CFUN=4” command is used to disable RF
+CIEV: 100	CME Error: Unknown error.

3.8. Mobile Termination Error Control

3.8.1. +CMEE Report Mobile Equipment Error

Description	Command	Possible Response(s)
Set error mode	+CMEE=[<n>]	OK +CME ERROR: <err>
Get current mode	+CMEE?	+CMEE: <n> OK
Get supported values	+CMEE=?	+CMEE: (list of supported <n>s) OK

3.8.1.1. Parameters

<mode>	Description
0	Disable +CME ERROR: <err> result code and use ERROR instead
1	Enable +CME ERROR: <err> result code and use numeric <err> values
2	Enable +CME ERROR: <err> result code and use verbose <err> values

3.9. Mobile Termination Error Result Code

3.9.1. +CME ERROR

Description	Result Code
Error type	+CME ERROR: <err>

3.9.1.1. General Error

Numeric Mode	Verbose Mode
0	Phone failure
1	No connection to phone
2	Phone-adaptor link reserved
3	Operation not allowed
4	Operation not supported
5	PH-SIM PIN required
6	PH-FSIM PIN required
7	PH-FSIM PUK required
10	SIM not inserted (Note)
11	SIM PIN required
12	SIM PUK required
13	SIM failure (Note)
14	SIM busy (Note)
15	SIM wrong (Note)
16	Incorrect password
17	SIM PIN2 required
18	SIM PUK2 required
20	Memory full
21	Invalid index
22	Not found
23	Memory failure
24	Text string too long
25	Invalid characters in text string
26	Dial string too long
27	Invalid characters in dial string
30	No network service
31	Network timeout
32	Network not allowed - emergency calls only
40	Network personalization PIN required
41	Network personalization PUK required
42	Network subset personalization PIN required

Numeric Mode	Verbose Mode
43	Network subset personalization PUK required
44	Service provider personalization PIN required
45	Service provider personalization PUK required
46	Corporate personalization PIN required
47	Corporate personalization PUK required
50	Incorrect parameters
94	Length error
99	Resource limitation (for +CCWA command only)
100	Unknown
515	Not Ready

Note: This error code is also applicable to UICC.

3.9.1.2. GPRS-related Error

Numeric Mode	Verbose Mode
103	Illegal MS
106	Illegal ME
107	GPRS services not allowed
111	PLMN not allowed
112	Location area not allowed
113	Roaming not allowed in this location area
132	Service option not supported
133	Requested service option not subscribed
134	Service option temporarily out of order
149	PDP authentication failure
150	Invalid mobile class
148	Unspecified GPRS error

3.10. Commands for Packet Domains

3.10.1. +CGDCONT Define PDP Context

Description	Command	Possible Response(s)
Define a PDP	<code>+CGDCONT=[<cid>[,<PDP_type>[,<APN>[,<PDP_addr>[,<d_comp>[,<h_comp>]]]]]]]</code>	OK +CME ERROR: <err>

Description	Command	Possible Response(s)
List current defined PDP	+CGDCONT?	+CGDCONT: <cid>, <PDP_type>, <APN>, <PDP_addr>, <data_comp>, <head_comp> [<CR><LF>+CGDCONT: <cid>, <PDP_type>, <APN>, <PDP_addr>, <data_comp>, <head_comp> [...]] OK +CME ERROR: <err>
Get supported values	+CGDCONT=?	+CGDCONT: (range of supported <cid>s), <PDP_type>,,, (list of supported <d_comp>s), (list of supported <h_comp>s) [<CR><LF>+CGDCONT: (range of supported <cid>s), <PDP_type>,,, (list of supported <d_comp>s), (list of supported <h_comp>s) [...]] OK +CME ERROR: <err>

3.10.1.1. Parameters

<cid>	Description
1	PDP Context Identifier 1 Definition stored in non-volatile memory
2	PDP Context Identifier 2 Definition stored in non-volatile memory
3 (default)	PDP Context Identifier 3 Locked in non-volatile memory and is always defined.

<PDP_type>	Description
"IP"	Internet Protocol (IETF STD 5)
"PPP"	Point to Point Protocol (IETF STD 51)

<APN>	Description
String type	Access Point Name If the value is null or omitted, then the subscription value will be requested

<PDP_addr>	Description
String type	IP address Format: "<n>.<n>.<n>.<n>" where <n>=0..255 If the value is null or equals 0.0.0.0 a dynamic address will be requested. The allocated address may be read using the +CGPADDR command

<d_comp>	Description
0	PDP data compression off Default if value is omitted

<h_comp>	Description
0	PDP header compression off Default if value is omitted

3.10.1.2. Notes

For <cid> 1, 2, and 3, PDP context definition is stored in non-volatile memory i.e parameters provided in +CGDCONT for PDP context definition and PDP context status (defined/undefined) are stored in non-volatile memory (if a PDP has been defined with +CGDCONT, after a switch off / switch on, AT+CGDCONT? will list the PDP has defined).

<cid> 3 is locked. This means that TE is not allowed to modify definition and parameters of <cid>=3 with +CGDCONT set command. This gives a default PDP context with parameters that TE cannot change.

<cid> 3 is also the default <cid>: if +CGDCONT with <cid> omitted is received, <cid> 3 will be used. +CGDCONT parameters are automatically saved into non-volatile memory.

3.10.2. +CGQREQ Quality of Service Profile (Requested)

Description	Command	Possible Response(s)
Set requested QOS (R97)	+CGQREQ=[<cid> [,<precedence>[,<delay> [,<reliability>[,<peak> [,<mean>]]]]]]	OK +CME ERROR: <err>
Get current settings	+CGQREQ?	+CGQREQ: <cid>,<precedence>,<delay>,<reliability>,<peak>,<mean> [<CR><LF>+CGQREQ: <cid>,<precedence>,<delay>,<reliability>,<peak>,<mean> [...]] OK +CME ERROR: <err>

Description	Command	Possible Response(s)
Get supported values	+CGQREQ=?	+CGQREQ: <PDP_type>, (list of supported <precedence>s), (list of supported <delay>s), (list of supported <reliability>s) , (list of supported <peak>s), (list of supported <mean>s) [<CR><LF>+CGQREQ: <PDP_type>, (list of supported <precedence>s), (list of supported <delay>s), (list of supported <reliability>s), (list of supported <peak>s), (list of supported <mean>s) [...]] OK +CME ERROR: <err>

3.10.2.1. Parameters

<cid>	Description
1..3	PDP Context Identifier Definition stored in non-volatile memory (refer to section 3.10.1 +CGDCONT Define PDP Context)

<precedence>	Description
0 (default)	QOS precedence class subscribed value
1..3	QOS precedence class

<delay>	Description
0 (default)	QOS delay class subscribed value
1..4	QOS delay class subscribed

<reliability>	Description
0	QOS reliability class subscribed value
1..5	QOS reliability class Default value: 3

<peak>	Description
0 (default)	QOS peak throughput class subscribed value
1..9	QOS peak throughput class

<mean>	Description
0 (default)	QOS mean throughput class subscribed value

<mean>	Description
1..18	QoS mean throughput class
31	QoS mean throughput class best effort

3.10.2.2. Notes

Refer to § 6.1.2 for QoS mapping between R99 and R97/R98 QoS.

3.10.3. +CGQMIN Quality of Service Profile (Minimum Acceptable)

Description	Command	Possible Response(s)
Set minimum QoS (R97)	+CGQMIN=[<cid> [,<precedence>[,<delay> [,<reliability>[,<peak> [,<mean>]]]]]]	OK +CME ERROR: <err>
Get current settings	+CGQMIN?	+CGQMIN: <cid>,<precedence>,<delay>,<reliability>,<peak>,<mean> [<CR><LF>+CGQMIN: <cid>,<precedence>,<delay>,<reliability>,<peak>,<mean> [...]] OK +CME ERROR: <err>
Get supported values	+CGQMIN=?	+CGQMIN: <PDP_type>, (list of supported <precedence>s), (list of supported <delay>s), (list of supported <reliability>s), (list of supported <peak>s), (list of supported <mean>s) [<CR><LF>+CGQMIN: <PDP_type>, (list of supported <precedence>s), (list of supported <delay>s), (list of supported <reliability>s), (list of supported <peak>s), (list of supported <mean>s) [...]] OK +CME ERROR: <err>

3.10.3.1. Parameters

Refer to section 3.10.2 +CGQREQ Quality of Service Profile (Requested).

3.10.3.2. Notes

Refer to § 6.1.2 for QoS mapping between R99 and R97/R98 QoS.

3.10.4. +CGATT PS Attach or Detach

Description	Command	Possible Response(s)
Attach or detach	+CGATT=[<state>]	OK +CME ERROR: <err>
Get current state	+CGATT?	+CGATT: <state> OK +CME ERROR: <err>
Get supported states	+CGATT=?	+CGATT: (list of supported <state>s) OK +CME ERROR: <err>

3.10.4.1. Parameters

<state>	Description
0 (default)	Detached
1	Attached

3.10.5. +CGACT PDP Context Activate or Deactivate

Description	Command	Possible Response(s)
Activate or deactivate a PDP	+CGACT=[<state> [,<cid>[,<cid>[,...]]]]	OK +CME ERROR: <err>
Get current PDPs state	+CGACT?	+CGACT: <cid>,<state> [<CR><LF>+CGACT: <cid>,<state> [...]] OK +CME ERROR: <err>
Get supported states	+CGACT=?	+CGACT: (list of supported <state>s) OK +CME ERROR: <err>

3.10.5.1. Parameters

<state>	Description
0	Deactivated
1	Activated

<cid>	Description
1..3	PDP Context Identifier

3.10.5.2. Notes

This command is used to tests PDPs with network simulators. Successful activation of PDP on real network is not guaranteed, as it depends on whether the real network supports GPRS/EDGE service. Refer to section 3.10.7 +CGDATA Enter Data for more information.

Examples:

To activate all defined contexts:

```
AT+CGACT=1
```

To deactivate all defined contexts:

```
AT+CGACT=0
```

To activate context 1:

```
AT+CGACT=, 1
```

or

```
AT+CGACT=1, 1
```

To activate context 2:

```
AT+CGACT=, 2
```

or

```
AT=CGACT=1, 2
```

Note: Entering AT+CGACT= (no specified parameters) returns OK without activating or deactivating the PDP context.

3.10.6. +CGCMOD PDP Context Modify

Description	Command	Possible Response(s)
Request PDP context modification	+CGCMOD=[<cid>[,<cid>[,...]]]	OK +CME ERROR: <err>
Get active PDPs	+CGCMOD=?	+CGCMOD: (list of <cid>s associated with active contexts) OK +CME ERROR: <err>

3.10.6.1. Parameters

<cid>	Description
1..3	PDP Context Identifier

3.10.6.2. Notes

Recommendation specifies that after the command has completed, the MT returns to online data state but "OK" result code is expected: this seems inconsistent.

From a Sierra Wireless point of view, +CGCMOD behaviour is more similar to +CGACT command, hence the implementation choice is not to switch link to online data mode after PDP context modification.

TE will have to send +++ escape sequence to switch channel to online command if +CGCMOD cannot be performed from another AT channel. TE will have to use O command, if required, to switch channel to online data mode.

3.10.7. +CGDATA Enter Data State

Description	Command	Possible Response(s)
Enter data state	+CGDATA[=<L2P>, [<cid>]]	CONNECT +CME ERROR: <err>
Get supported values	+CGDATA=?	+CGDATA: (list of supported <L2P>s) OK +CME ERROR: <err>

3.10.7.1. Parameters

<L2P>	Description
"PPP"	Point-to-point protocol for a PDP such as IP

<cid>	Description
1..3	PDP Context Identifier

3.10.7.2. Notes

If no parameters are provided (i.e +CGDATA<CR>), the last <cid> activated with +CGACT or the default <cid> is used.

Only one <cid> in the command is supported (i.e. +CGDATA="PPP", <cid><CR>).

This command is used for PDP tests on network emulators. On real network functioning of +CGACT and then +CGDATA for data transfer is not guaranteed.

+CGDATA implementation does not perform PS attach or PDP context activation. The PDP identified by <cid>, when provided, in +CGDATA must have been activated previously thanks to +CGACT command.

+CGDATA only switches channel to online data mode and open PPP server in a proprietary mode called "FTA mode" (In this mode PPP only acts as a relay).

For IP over PPP services, ATD*98 or ATD*99 commands must be used: when activating a PDP context, PCO (protocol configuration option) has to be provided to network. PCO can be provided to network only if a PPP negotiation (LCP/NCP negotiation) has been initiated between mobile and TE before PDP activation (refer to TS 27.060 §9.1). This negotiation is possible only if AT channel is switched to online data mode before PDP context activation. Hence, the PDP identified with <cid> in +CGDATA should not have been activated by +CGACT → not possible in the current implementation (+CGDATA does not behaves as ATD*9x when <cid> is not activated).

To go back in online command, the "+++" escape sequence has to be sent on link in data mode.

+CGDATA can also be used to switch again channel to online data mode (after "+++") if PDP is still active (same behaviour has ATO command).

3.10.7.3. PDP Test Use Case

AT Commands	Comments
AT+CGACT=1,1 OK	PDP 1 is activated No PCO negotiation
AT+CGDATA CONNECT	PPP server is opened in FTA mode, channel is switched in online data mode No LCP/NCP negotiation
Data transfer	
+++ OK	Channel is back to online command mode
ATH OK	PPP server FTA mode is closed but PDP is NOT deactivated
AT+CGACT=0,1 OK	PDP 1 is deactivated. (If ATH is not sent before deactivation, +CGACT returns ERROR)

3.10.8. +CGPADDR Show PDP Address

Description	Command	Possible Response(s)
Get PDP addresses	+CGPADDR[=<cid> [,<cid> [...]]]	+CGPADDR: <cid>,<PDP_addr> [<CR><LF>+CGPADDR: <cid>,<PDP_addr> [...]] OK +CME ERROR: <err>

Description	Command	Possible Response(s)
Get defined <cid>	+CGPADDR=?	+CGPADDR: (list of defined <cid>s) OK +CME ERROR: <err>

3.10.8.1. Parameters

<cid>	Description
1..3	PDP Context Identifier

<PDP_addr>	Description
String type	IP address Format: "<n>.<n>.<n>.<n>" where <n>=0..255

3.10.8.2. Notes

Set command return address provided by the network if a connection has been established.

3.10.9. +CGCLASS GPRS Mobile Station Class

Description	Command	Possible Response(s)
Set mode of operation	+CGCLASS=[<class>]	OK +CME ERROR: <err>
Get current mode	+CGCLASS?	+CGCLASS: <class> OK +CME ERROR: <err>
Get supported mode	+CGCLASS=?	+CGCLASS: (list of supported <class>s) OK +CME ERROR: <err>

3.10.9.1. Parameters

<class>	Description
"B" (default)	Class-B mode of operation (A/Gb mode), (not applicable in lu mode) MT would operate PS and CS services but not simultaneously

<class>	Description
"CC"	Class-C mode of operation in CS only mode (A/Gb mode), or CS (lu mode) (lowest mode of operation) MT would only operate CS services

3.10.9.2. Notes

Module switch back to class B attaches to GPRS network automatically.

3.10.10. +CGREG GPRS Network Registration Status

Description	Command	Possible Response(s)
Set registration notification mode	+CGREG= [<n>]	OK +CME ERROR: <err>
Get current registration information	+CGREG?	+CGREG: <n>,<stat>[,<lac>,<ci>] OK +CME ERROR: <err>
Get supported values	+CGREG=?	+CGREG: (list of supported <n>s) OK +CME ERROR: <err>

3.10.10.1. Parameters

<n>	Description
0 (default)	Disable network registration unsolicited result code
1	Enable network registration unsolicited result code +CGREG: <stat>
2	Enable network registration and location information unsolicited result code +CGREG: <stat>[,<lac>,<ci>]

<stat>	Description
0	Not registered, MT is not currently searching an operator to register to The GPRS service is disabled, the UE is allowed to attach for GPRS if requested by the user
1	Registered, home network
2	Not registered, but MT is currently trying to attach or searching an operator to register to The GPRS service is enabled, but an allowable PLMN is currently not available. The UE will start a GPRS attach as soon as an allowable PLMN is available.
3	Registration denied The GPRS service is disabled, the UE is not allowed to attach for GPRS if requested by the user.

<stat>	Description
4	Unknown
5	Registered, roaming

<lac>	Description
String type	Two bytes location area code in hexadecimal format (e.g. "00C3" equals 195 in decimal)

<ci>	Description
String type	Two bytes cell ID in hexadecimal format

3.10.10.2. Notes

+CGREG parameter is automatically saved into non-volatile memory.

The <n> parameter is restored to default value by AT&F command.

3.10.11. +CGSMS Select Service for MO SMS Messages

Description	Command	Possible Response(s)
Set SMS service	+CGSMS= <service>	OK +CME ERROR: <err>
Get current service	+CGSMS?	+CGSMS: <service> OK +CME ERROR: <err>
Get supported values	+CGSMS=?	+CGSMS: (list of currently available <service>s) OK +CME ERROR: <err>

3.10.11.1. Parameters

<service>	Description
0	Packet Domain
1	Circuit Switched
2	Packet Domain preferred (use Circuit Switched if GPRS not available)
3	Circuit Switched preferred (use Packet Domain if Circuit Switched not available)

3.10.11.2. Notes

When <service> value is 2, the SMS is sent on GPRS network if already attached. Otherwise it is sent on circuit switched network. If an error occurs on the GPRS network, no further attempt is made.

The <service> parameter is not stored in non-volatile memory and <service>=1 will be used every time the module reboots.

3.10.12. Request Packet Domain Service 'D'

Description	Command	Possible Response(s)
Request packet domain service	D*99[*[<called_address>][* [<L2P>] [*<cid>]]]#	CONNECT +CME ERROR: <err>

3.10.12.1. Parameters

<called_address>	Description
String type	Called party in the address space applicable to the PDP Only empty string is allowed.

<L2P>	Description
1	PPP

<cid>	Description
1..3	PDP Context Identifier

3.10.12.2. Notes

If <cid> omitted, default <cid> (3) will be used.

If <cid> correspond to an already active PDP context (activated with +CGACT command) ERROR will be returned, the PDP must be in quiescent state before ATD*9x.

3.10.13. Request Packet Domain IP Service 'D'

Description	Command	Possible Response(s)
Request packet domain IPservice	D*98[*<cid>]#	CONNECT +CME ERROR: <err>

3.10.13.1. Parameters

<cid>	Description
1..3	PDP Context Identifier

3.10.13.2. Notes

If <cid> omitted, default <cid> (3) will be used.

If <cid> correspond to an already active PDP context (activated with +CGACT command) ERROR will be returned, the PDP must be in quiescent state before ATD*9x.

3.10.14. +CGEREP Packet Domain Event Reporting

Description	Command	Possible Response(s)
Set +CGEV notification mode	+CGEREP=[<mode>[,<bfr>]]	OK +CME ERROR: <err>
Get current settings	+CGEREP?	+CGEREP: <mode>,<bfr> OK +CME ERROR: <err>
Get supported values	+CGEREP=?	+CGEREP: (list of supported <mode>s), (list of supported <bfr>s) OK +CME ERROR: <err>

3.10.14.1. Parameters

<mode>	Description
0 (default)	Buffer unsolicited result codes in the MT; if MT result code buffer is full, the oldest ones are discarded.
1	Discard unsolicited result codes when MT TE link is reserved (e.g. in on line data mode); otherwise forward them directly to the TE
2	Buffer unsolicited result codes in the MT when MT TE link is reserved (e.g. in on line data mode) and flush them to the TE when MT TE link becomes available; otherwise forward them directly to the TE

<bfr>	Description
0 (default)	MT buffer of unsolicited result codes defined within this command is cleared when <mode> 1 or 2 is entered
1	MT buffer of unsolicited result codes defined within this command is flushed to the TE when <mode> 1 or 2 is entered

3.10.14.2. Notes

+CGEREP parameters are automatically saved into non-volatile memory.

3.11. Packet Domains Result Codes

3.11.1. +CGREG Registration Status

Description	Result Code
Registration change	+CGREG: <stat>[,<lac>,<ci>]

3.11.1.1. Parameters

<stat>	Description
0	Not registered, MT is not currently searching an operator to register to. The GPRS service is disabled, the UE is allowed to attach for GPRS if requested by the user.
1	Registered, home network
2	Not registered, but MT is currently trying to attach or searching an operator to register to. The GPRS service is enabled, but an allowable PLMN is currently not available. The UE will start a GPRS attach as soon as an allowable PLMN is available.
3	Registration denied The GPRS service is disabled, the UE is not allowed to attach for GPRS if requested by the user.
4	Unknown
5	Registered, roaming

<lac>	Description
String type	Two bytes location area code in hexadecimal format (e.g. "00C3" equals 195 in decimal)

<ci>	Description
String type	Two bytes cell ID in hexadecimal format

>> 4. ITU-T V25.ter Commands

4.1. Call Control

4.1.1. A Answer

Description	Command	Possible Response(s)
Answer a MT call	A	OK ERROR

4.1.2. D Dial

Description	Command	Possible Response(s)
Initiate an MO call	D[<dialstring>] [<G>] [;]	OK CONNECT [<speed>] BUSY NO CARRIER NO ANSWER NO DIALTONE +CME ERROR: <err>

4.1.2.1. Parameters

<dialstring>	Description
Dialling digits	0 1 2 3 4 5 6 7 8 9 * # + A B C ,

<G>	Description
G	Activate CUG supplementary service information
g	Deactivate CUG supplementary service information

<speed>	Description
9600	Data call baudrate

4.1.2.2. Notes

The result code “OK” can be sent immediately after call setup or only once call is connected to remote party. Refer to section 8.7.4 *PSCSSC Call Successful for more details.

Semicolon character (;) shall be added when voice call is originated.

4.1.3. D> Direct Dialling From Phone Book

Description	Command	Possible Response(s)
Initiate an MO call	D<str>[;] D[<mem>]<n>[<G>] [;]	OK CONNECT [<speed>] BUSY NO CARRIER NO ANSWER NO DIALTONE +CME ERROR: <err>

4.1.3.1. Parameters

<str>	Description
String	Alphanumeric string with double quotes

<mem>	Description
Memory	Memory storage (“ME”, “SM”)

<n>	Description
index	Memory location index

<G>	Description
G	Activate CUG supplementary service information
g	Deactivate CUG supplementary service information

<speed>	Description
9600	Data call baudrate

4.1.4. H Hang Up

Description	Command	Possible Response(s)
Hang up a call	H[<value>]	OK +CME ERROR: <err>

4.1.4.1. Parameters

<value>	Description
0 (default value)	Disconnect all calls on the channel the command is requested. All active or waiting calls, CS data calls, GPRS call of the channel will be disconnected.
1	Disconnect all calls on all connected channels. All active or waiting calls, CSD calls, GPRS call will be disconnected (clean up of all calls of the ME).
2	Disconnect all connected CS data call only on the channel the command is requested. Speech calls (active or waiting) or GPRS calls are not disconnected.
3	Disconnect all connected GPRS calls only on the channel the command is requested. Speech calls (active or waiting) or CS data calls are not disconnected.
4	Disconnect all CS calls (either speech or data) but does not disconnect waiting call (either speech or data) on the channel the command is requested.
5	Disconnect waiting call (either speech or data) but does not disconnect other active calls (CS speech, CS data or GPRS) on the channel the command is requested. (Rejection of incoming call).

4.1.4.2. Notes

Voice call disconnection is also dependant of +CVHU settings.

4.1.5. L Monitor Speaker Loudness

Description	Command	Possible Response(s)
Set Loudness	L<volume>	OK +CME ERROR: <err>

4.1.5.1. Parameters

<volume>	Description
0..9	Volume

4.1.5.2. Notes

This command is supported for compatibility purpose and has no effect on ME (simple response OK).

4.1.6. M Monitor Speaker Mode

Description	Command	Possible Response(s)
Set mode	M <mode>	OK +CME ERROR: <err>

4.1.6.1. Parameters

<mode>	Description
0..9	Mode

4.1.6.2. Notes

This command is supported for compatibility purpose and has no effect on ME (simple response OK).

4.1.7. O Online

Description	Command	Possible Response(s)
Switch to online mode	O [<type>]	CONNECT [<speed>] NO CARRIER

4.1.7.1. Parameters

<type>	Description
0 (default value)	Return to online data state from online command state.

<speed>	Description
9600	Data rate

4.1.8. P Pulse Dialling

Description	Command	Possible Response(s)
Pulse dialling	P	OK

4.1.8.1. Notes

This command is supported for compatibility purpose and has no effect on ME (simple response OK).

4.1.9. S0 Automatic Answer

Description	Command	Possible Response(s)
Set automatic answer	S0=<num>	OK +CME ERROR: <err>
Read current register value	S0?	<num> OK +CME ERROR: <err>

4.1.9.1. Parameters

<num>	Description
0 (default)	No automatic answer
1..255	Number of rings the modem will wait for before answering the phone if a ring is detected

4.1.9.2. Notes

The <num> parameter is saved into non-volatile memory by AT&W command and restored to default value by AT&F command.

4.1.10. S6 Pause Before Blind Dialling

Description	Command	Possible Response(s)
Set pause duration	S6=<time>	OK +CME ERROR: <err>

4.1.10.1. Parameters

<time>	Description
0..999	Time

4.1.10.2. Notes

This command is supported for compatibility purpose and has no effect on ME (simple response OK).

4.1.11. S7 Connection Completion Timeout

Description	Command	Possible Response(s)
Set timeout	S7=<time>	OK +CME ERROR: <err>
Read current register value	S7?	<time> OK +CME ERROR: <err>

4.1.11.1. Parameters

<time>	Description
1..255	Amount of time the modem will wait for the carrier signal from the remote modem. If a carrier is not received in this time, the modem will hang up and send the NO CARRIER result code.

4.1.12. S8 Comma Dial Modifier

Description	Command	Possible Response(s)
Set time	S8=<time>	OK +CME ERROR: <err>
Read current register value	S8?	<time> OK +CME ERROR: <err>

4.1.12.1. Parameters

<time>	Description
0..255	Amount of time the modem will pause when it detects a comma in the dialling string

4.1.12.2. Notes

Comma is not supported in dial string; this command has no effect on ME (simple response OK).

4.1.13. S10 Automatic Disconnect Delay

Description	Command	Possible Response(s)
Set time	S10=<time>	OK +CME ERROR: <err>
Read current register value	S10?	<time> OK +CME ERROR: <err>

4.1.13.1. Parameters

<time>	Description
1..254	Amount of time from when the modem recognizes a loss of carrier to when it will hang up

4.1.13.2. Notes

This command is supported for compatibility purpose and has no effect on ME (simple response OK).

4.1.14. T Tone Dialling

Description	Command	Possible Response(s)
Set dial tone	T	OK

4.1.14.1. Notes

This command is supported for compatibility purpose and has no effect on ME (simple response OK).

4.2. General TA Control Commands

4.2.1. A/ Repeat last command

Description	Command	Possible Response(s)
Repeat the last command line	A/	Same as the last command

4.2.2. I Identification Information

Description	Command	Possible Response(s)
Request identification information	I[<value>]	<text> OK +CME ERROR: <err>

4.2.2.1. Parameters

<value>	Description
0 (default)	Get model id
1	Ignored
2	Ignored
3	Get software version (L30_00gg.WS6318 <date>)
4	Get manufacturer id and model id
5	Get manufacturer id
6..7	Ignored

4.2.3. Z Reset Default Configuration

Description	Command	Possible Response(s)
Reset to default configuration	Z[<value>]	OK +CME ERROR: <err>

4.2.3.1. Parameters

<value>	Description
0 (default value)	Restore profile 0

<value>	Description
1	Restore profile 1

4.2.3.2. Notes

Parameter impacted by Z command:

Command	Parameter Name	Default Value
E	<echo>	0x01
Q	<result>	0x00
V	<format>	0x01
X	<result>	0x04
&C	<behavior>	0x01
&D	<behavior>	1
&S	<override>	0
&R	<option>	0x01
+IFC	<TA_by_TE>	0x02
+IFC	<TE_by_TA>	0x02
+FCLASS	<class>	0x00
S0	<num>	0x00
S1	<num>	0x00
S3	<char>	0x0D
S4	<char>	0x0A
S5	<char>	0x08
S7	<time>	0x64
S8	<time>	0x02
S10	<time>	0x0E

4.2.4. &F Factory Defined Configuration

Description	Command	Possible Response(s)
Reset to factory configuration	&F [<value>]	OK +CME ERROR: <err>

4.2.4.1. Parameters

<value>	Description
0 (default value)	Set to factory configuration

4.2.4.2. Notes

Parameters impacted by &F command:

Command	Parameter Name	Default Value
E	<echo>	0x01
Q	<result>	0x00
V	<format>	0x01
X	<result>	0x04
&S	<override>	0x00
+IFC	<TA_by_TE>	0x02
+IFC	<TE_by_TA>	0x02
S0	<num>	0x00
S1	<num>	0x00
S3	<char>	0x0D (13)
S4	<char>	0x0A (10)
S5	<char>	0x08
S7	<time>	0x64
S8	<time>	0x02
S10	<time>	0x0E
+CRLP	<ver>	0x00
+CRLP	<T4>	0x07

Command	Parameter Name	Default Value
+CRLP	<iws>	0x3D(61)
+CRLP	<mws>	0x3D(61)
+CRLP	<T1>	0x30(48)
+CRLP	<N2>	0x06
+CEER	<cause_select >	0x00
+CEER	<cause >	0x00
+CPBS	<storage>	"SM"
+CSMP	<fo>	0x11(17)
+CSMP	<vp>	0xA7(167)
+CSMP	<pid>	0x00
+CSMP	<dc>	0x00
+CR	<mode>	0x00
+CSTA	<type>	0x81
+CBST	<speed>	0x07
+CBST	<name>	0x00
+CBST	<ce>	0x01
+CRC	<mode>	0x00
+CMOD	<mode>	0x00
+CMEE	<n>	0x00
+CREG	<n>	0x00
+CGREG	<n>	0x00
+CSMS	<service>	0x00
+CMER	<ind>	0x00
+CMER	<mode>	0x00
+CMGF	<mode>	0x00
+CSDH	<show>	0x00
+CSCS	<chset>	"IRA"
+CVHU	<mode>	0x00

Command	Parameter Name	Default Value
+CLIR	<n>	0x00
+CLIP	<n>	0x00
+COLP	<n>	0x00
+CSSN	<n>	0x00
+CSSN	<m>	0x00
+CFUN	<fun>	0x01
+PSSREP	<act>	0x00
&C	<behaviour>	0x01
&D	<behaviour>	0x01
&R	<option>	0x01
+SIDET	<analog gain>	0007
+SIDET	<digital_gain>	1CA8
+SPEAKER	<speaker>	1
+WAUDPROF	<profile>	0
+WDDM	<mode>	0
+WDGR	<Rgain>	09EE (if <Configuration>=1) 13EE (if <Configuration>=2)
+WDGT	<Tgain>	0CEE (if <Configuration>=1) 09EE (if <Configuration>=2)
+WPCM	<Clock Rate>	0
+WPCM	<Sampling Edge>	0
+WPCM	<Bit Word>	1
+WPCM	<MSB First>	1

4.2.5. +GCAP Complete Capabilities List

Description	Command	Possible Response(s)
Get list	+GCAP	+GCAP:<list> OK ERROR

4.2.5.1. Parameters

<list>	Description
String type	List of capabilities: +FCLASS,+CGSM

4.2.6. +GMI Manufacturer Identification

Description	Command	Possible Response(s)
Get manufacturer id	+GMI	<manufacturer> OK
Test if command is supported	+GMI=?	OK

4.2.6.1. Parameters

<manufacturer>	Description
String type	Manufacturer id (SIERRA WIRELESS MODEM)

4.2.7. +GMM Model Identification

Description	Command	Possible Response(s)
Get model id	+GMM	<model> OK
Test if command is supported	+GMM=?	OK

4.2.7.1. Parameters

<model>	Description
String type	Model id

4.2.8. +GMR Revision Identification

Description	Command	Possible Response(s)
Get model id	+GMR	<revision> OK
Test if command is supported	+GMR=?	OK

4.2.8.1. Parameters

<revision>	Description
String type	Revision id (L30_00gg.WS6318 <date>)

4.2.9. +GSN Serial Number Identification

Description	Command	Possible Response(s)
Get model id	+GSN	<sn> OK
Test if command is supported	+GSN=?	OK

4.2.9.1. Parameters

<sn>	Description
String type	IMEI (15 digits)

4.3. TA-TE Interface Commands

4.3.1. E Echo

Description	Command	Possible Response(s)
Control echo	E[<echo>]	OK ERROR

4.3.1.1. Parameters

<echo>	Description
0	Characters echo disabled
1 (default)	Characters echo enabled
Omitted	<echo> 0 is used

4.3.1.2. Notes

E parameter is saved into non-volatile memory using AT&W command and restored to default value by AT&F command.

4.3.2. Q Result Code Suppression

Description	Command	Possible Response(s)
Control result code	Q[<result>]	OK ERROR

4.3.2.1. Parameters

<result>	Description
0 (default)	Result codes are transmitted to TE
1	Result codes are suppressed

4.3.2.2. Notes

Q parameter is saved into non-volatile memory by AT&W command and restored to default value by AT&F command.

4.3.3. S3 Line Termination Character

Description	Command	Possible Response(s)
Set line termination character	S3=<char>	OK ERROR
Get current value	S3?	<char> OK

4.3.3.1. Parameters

<char>	Description
13 (default)	Termination character <CR>

4.3.3.2. Notes

S3 parameter is saved into non-volatile memory by AT&W command and restored to default value by AT&F command.

4.3.4. S4 Response Formatting Character

Description	Command	Possible Response(s)
Set response formatting character	S4=<char>	OK ERROR
Get current value	S4?	<char> OK

4.3.4.1. Parameters

<char>	Description
10 (default)	Termination character <LF>

4.3.4.2. Notes

S4 parameter is saved into non-volatile memory by AT&W command and restored to default value by AT&F command.

4.3.5. S5 Line Editing Character

Description	Command	Possible Response(s)
Set line editing character	S5=<char>	OK ERROR
Get current value	S5?	<char> OK

4.3.5.1. Parameters

<char>	Description
8 (default)	Editing character <BS>

4.3.5.2. Notes

S5 parameter is saved into non-volatile memory by AT&W command and restored to default value by AT&F command.

4.3.6. V TA Response Format

Description	Command	Possible Response(s)
Set response format	V[<format>]	OK 0 ERROR 4

4.3.6.1. Parameters

<format>	Description
0	Responses in numeric format
1	Responses in verbose format
Omitted	<format> 0 is used

4.3.7. X Result Code Selection and Call Progress Monitoring

Description	Command	Possible Response(s)
Set result code selection	X<result>	OK ERROR

4.3.7.1. Parameters

<result>	Description
0	CONNECT result code is given upon entering online data state. Dial tone and busy detection are disabled.

<result>	Description
1	CONNECT <text> result code is given upon entering online data state. Dial tone and busy detection are disabled.
2	CONNECT <text> result code is given upon entering online data state. Dial tone detection is enabled, and busy detection is disabled.
3	CONNECT <text> result code is given upon entering online data state. Dial tone detection is disabled, and busy detection is enabled.
4	CONNECT <text> result code is given upon entering online data state. Dial tone and busy detection are both enabled.

4.3.8. &C DCD Behaviour

Description	Command	Possible Response(s)
Set DCD behaviour	&C<behaviour>	OK ERROR

4.3.8.1. Parameters

<behaviour>	Description
0	DCE always presents the ON condition on circuit 109.
1 (default)	Circuit 109 changes in accordance with the underlying DCE.

4.3.8.2. Notes

&C parameter is saved into non-volatile memory by AT&W command and restored to default value by AT&F command.

4.3.9. &D DTR Behaviour

Description	Command	Possible Response(s)
Set DTR behaviour	&D<behaviour>	OK ERROR

4.3.9.1. Parameters

<behaviour>	Description
0	DCE ignores circuit 108/2.
1 (default)	Upon an on-to-off transition of circuit 108/2, the DCE enters online command state and issues an OK result code; the call remains connected.

<behaviour>	Description
2	Upon an on-to-off transition of circuit 108/2, the DCE instructs the underlying DCE to perform an orderly cleardown of the call

4.3.9.2. Notes

In case of "Drop DTR", if the signal remains in the off state more than two seconds, it is considered as a PC disconnection and no "OK" is sent to the TE (cable considered unplugged).

The behaviour of the command complies to the recommendation description only with DTR pulses (pulse means DTR signal stays in the off state less than two seconds).

&D parameter is saved into non-volatile memory by AT&W command and restored to default value by AT&F command.

4.3.10. +IPR Fixed TE Rate

Description	Command	Possible Response(s)
Set TE rate	+IPR=<rate>	OK ERROR
Get current rate	+IPR?	+IPR: <rate> OK
Get supported values	+IPR=?	+IPR: (list of supported auto-detectable <rate>s)[,(list of supported fixed-only <rate>s)] OK

4.3.10.1. Parameters

<rate>	Description
0	Automatic rate detection
1200	1200 bps
2400	2400 bps
4800	4800 bps
9600	9600 bps
19200	19200 bps
38400	38400 bps
57600	57600 bps
115200 (default)	115200 bps

4.3.10.2. Notes

+IPR parameter is automatically saved in non-volatile memory.

When in Auto-Baud (+IPR=0):

- the capital letter A must be entered to detect the DTE baud rate.
- all AT commands must be in capital letters.

4.3.11. +ICF TE-TA Character Framing

Description	Command	Possible Response(s)
Set TE-TA character framing	+ICF=[<format>[,<parity>]]	OK +CME ERROR: <err>
Get current value	+ICF?	+ICF: <format>,<parity> OK
Get supported values	+ICF=?	+ICF: (list of supported <format>s), (list of supported <parity>s) OK

4.3.11.1. Parameters

<format>	Description
3 (default)	8 data bits, 1 stop bit

<parity>	Description
3 (default)	space

4.3.11.2. Notes

This command is supported for compatibility purpose and has no effect on ME.

It provides information on hardware capabilities.

4.3.12. +IFC TE-TA Local Flow Control

Description	Command	Possible Response(s)
Set TE-TA local flow	+IFC=[<TA_by_TE>[,<TE_by_TA>]]	OK +CME ERROR: <err>

Description	Command	Possible Response(s)
Get current value	+IFC?	+IFC: <TA_by_TE>,<TE_by_TA> OK
Get supported values	+IFC=?	+IFC: (list of supported <TA_by_TE>s), (list of supported <TE_by_TA >s) OK

4.3.12.1. Parameters

<TA_by_TE>	Description
0	No flow control
1	Software flow control
2 (default)	Hardware flow control

<TE_by_TA>	Description
0	No flow control
1	Software flow control
2 (default)	Hardware flow control

4.3.12.2. Notes

This command configures the flow control mode.

+IFC parameters are saved into non-volatile memory by AT&W command and restored to default value by AT&F command.

Hardware flow control is supported as of Firmware L20 and later versions.

4.4. Result Codes

Verbose Result Code (Command V1 Set)	Numeric Result Code (Command V0 Set)	Type	Description
BUSY	7	Final	Busy signal detected
CONNECT	1	Intermediate	Connection has been established
CONNECT <text>	Manufacturer specific	Intermediate	As CONNECT but manufacturer specific <text> gives additional information (e.g. connection data rate)
ERROR	4	Final	Command not accepted
NO ANSWER	8	Final	Connection completion timeout
NO CARRIER	3	Final	Connection terminated
NO DIALTONE	6	Final	No dialtone detected

Verbose Result Code (Command V1 Set)	Numeric Result Code (Command V0 Set)	Type	Description
OK	0	Final	Acknowledges execution of a command line
+CRING			
RING	2	Unsolicited	Incoming call signal from network

4.4.1.1. Parameters

<text>	Numeric value
2400	10
4800	11
9600	12
14400	13
19200	15
28800	17
38400	19
48000	21
56000	23
64000	25
33600	27

>> 5. Hayes Commands

5.1. Standard Hayes Commands

5.1.1. B Communication Option

Description	Command	Possible Response(s)
Set communication option	B [<standard>]	OK ERROR

5.1.1.1. Parameters

<standard>	Description
0..99	standard

5.1.1.2. Notes

This command is supported for compatibility purpose and has no effect on ME (simple response OK).

5.1.2. N Negotiate Handshake

Description	Command	Possible Response(s)
Set handshake	N [<option>]	OK ERROR

5.1.2.1. Parameters

<option>	Description
0..9	option

5.1.2.2. Notes

This command is supported for compatibility purpose and has no effect on ME (simple response OK).

5.1.3. S1 Ring Count

Description	Command	Possible Response(s)
Read ring count for last MT call	S1?	<num> OK

5.1.3.1. Parameters

<num>	Description
0..255	Counts the number of rings detected on the line. It is cleared if a ring is not detected over an eight seconds time period. Default value: 0

5.1.3.2. Notes

S1 parameter is saved into non-volatile memory by AT&W command and restored to default value by AT&F command.

5.1.4. S2 Escape Character

Description	Command	Possible Response(s)
Set escape character	S2=<esc>	OK ERROR
Read escape character	S2?	<esc> OK

5.1.4.1. Parameters

<esc>	Description
43	Escape character 43 (i.e '+')

5.1.5. S11 DTMF Dialling Speed

Description	Command	Possible Response(s)
Set DTMF dialling speed	S11=<time>	OK ERROR

5.1.5.1. Parameters

<time>	Description
0..999	DTMF dialling speed

5.1.5.2. Notes

This command is supported for compatibility purpose and has no effect on ME (simple response OK).

5.1.6. S95 Windows XP Compatibility

Description	Command	Possible Response(s)
Windows XP compatibility	S95=<time>	OK ERROR

5.1.6.1. Parameters

<time>	Description
0..999	Windows XP compatibility

5.1.6.2. Notes

This command is supported for compatibility purpose and has no effect on ME (simple response OK).

5.1.7. W Extended Result Code

Description	Command	Possible Response(s)
Set extended result code	W<mode>	OK ERROR

5.1.7.1. Parameters

<mode>	Description
0	Only result code CONNECT supported

5.2. Advanced Hayes Commands

5.2.1. &S DSR Option

Description	Command	Possible Response(s)
Set DSR option	&S<override>	OK ERROR

5.2.1.1. Parameters

<override>	Description
0 (default)	Causes DSR signal to be active at all times
1	Causes DSR signal to be active after answer tone has been detected and inactive after the carrier has been lost

5.2.1.2. Notes

Parameter stored by AT&W command.

5.2.2. &V Configuration Profile

Description	Command	Possible Response(s)
Display active profile	&V[<profile>]	<profiles information> OK ERROR

5.2.2.1. Parameters

<profile>	Description
0 (default)	Display ACTIVE PROFILE, STORED PROFILE 0 and STORED PROFILE 1 information

5.2.3. &W Store Active Profile

Description	Command	Possible Response(s)
Store active profile	&W [<profile>]	OK ERROR

5.2.3.1. Parameters

<profile>	Description
0 (default)	Store the current configuration in profile 0
1	Store the current configuration in profile 1

5.2.3.2. Notes

Execution command stores the active <profile>. Two profiles are supported but they are equivalent. Refer to the table below for Parameters stored by &W.

Command	Parameter Name	Displayed by &V
E	<echo>	Y
Q	<result>	Y
V	<format>	Y
X	<result>	Y
&C	<behavior>	Y
&D	<behavior>	Y
&S	<override>	Y
&R	<option>	Y
+CBST	<speed>	N
+CBST	<name>	N
+CBST	<ce>	N
+IFC	<TA_by_TE>	Y
+IFC	<TE_by_TA>	Y
+FCLASS	<class>	Y
+PSSLEEP	<mode>	N

Command	Parameter Name	Displayed by &V
+SPEAKER	<speaker>	N
+WDDM	<mode>	N
S0	<num>	Y
S1	<num>	N
S3	<char>	Y
S4	<char>	Y
S5	<char>	Y
S7	<time>	Y
S8	<time>	Y
S10	<time>	Y

>> 6. TIA IS-101 Commands

6.1. +VTS DTMF Generation

Description	Command	Possible Response(s)
Generate DTMF (Duration is set by +VTD)	+VTS="<DTMF>, . . . ,<DTMF>"	OK +CME ERROR: <err>
Get supported values	+VTS=?	+VTS: (list of supported <DTMF>s) OK

6.1.1. Parameters

<DTMF>	Description
Character type	Character in the set 0..9, #, *, A..D

6.1.2. Notes

This commands only works for speech calls in active state.

6.2. +VTD DTMF Duration

Description	Command	Possible Response(s)
Set DTMF duration	+VTD=<n>	OK +CME ERROR: <err>
Get current duration	+VTD?	+VTD: <n> OK
Get supported values	+VTD=?	+VTD: (list of supported <n>s) OK

6.2.1. Parameters

<n>	Description
0	Manufacturer specific duration
1..10	DTMF duration (in 100 ms steps)

6.3. +SPEAKER Select Audio Output

Description	Command	Possible Response(s)
Set output speaker	+SPEAKER=<speaker>	OK
Get output speaker	+SPEAKER?	+SPEAKER: <speaker> OK
Get supported speakers	+SPEAKER=?	+SPEAKER: (list of supported <speaker>s) OK

6.3.1. Parameters

<speaker>	Description
1 (default)	Speaker 1
2	Speaker 2
3	PCM

6.3.2. Examples

Command	Responses
AT+SPEAKER=?	+SPEAKER: (1-3) OK
AT+SPEAKER?	+SPEAKER: 1 OK
AT+SPEAKER=2	OK
AT+SPEAKER?	+SPEAKER: 2 OK
AT&W	OK
Reset the modem	

Command	Responses
AT+SPEAKER?	+SPEAKER: 2 OK
AT&F	OK
AT+SPEAKER?	+SPEAKER: 2 OK
Reset the modem	
AT+SPEAKER?	+SPEAKER: 1 OK
AT+SPEAKER=0	ERROR
AT+SPEAKER=3	OK Note: PCM enable

6.3.3. Notes

The parameters are stored in non-volatile memory using the AT&W command. The default value can be restored using AT&F.

6.4. +WTONE Play Single Tone

Description	Command	Possible Response(s)
Play single tone	+WTONE=<mode> [,<dest> ,<freq> [, [<gain>] [, [<duration>]]]]	OK +CME ERROR: <err>
Get supported parameters	+WTONE=?	OK

6.4.1. Parameters

<mode>	Description
0	Stop playing
1	Play a tone

<dest>	Description
1 (default)	Speaker 1
2	Speaker 2
3	PCM

<freq>	Description
1-4000	Tone frequency (in Hz). Default value if omitted: 440

<gain>	Description
0-255	Tone gain. Default value if omitted: 10 Refer to section 6.4.2 Attenuation Values for more information.

<duration>	Description
0-255	Tone duration (in 20 ms units). Default value if omitted: 50. The tone can be stopped by AT+WTONE=0 .

6.4.2. Attenuation Values

Tone Gain	255	228	181	128	64	32	16	8	4	2	1	0
Attenuation	-0.03	-1	-3	-6	-12	-18	-24	-30	-36	-42	-48	-∞

6.4.3. Examples

Command	Responses
AT+WTONE=?	OK
AT+WTONE?	ERROR
AT+WTONE1,2,800,50,255	OK (Play frequency 800Hz with gain 50 for (255*20ms) 5100ms on Speaker 2)
AT+WTONE=0	OK (Stop the tone)
AT+WTONE=1	OK (Play default frequency 440Hz with gain 10 for 1000ms on Speaker 1)

6.4.4. Notes

+WTONE parameters are not stored in non-volatile memory.

6.5. +VGR Receive Gain Selection

Description	Command	Possible Response(s)
Set receive gain	+VGR=<n>	OK +CME ERROR: <err>
Get receive gain	+VGR?	+VGR: <n> OK
Get supported receive gain	+VGR=?	+VGR: (list of supported <n>s) OK

6.5.1. Parameters

<n>	Description
1..10	Receive gain: 1 -34 dB 2 -29 dB 3 -24 dB 4 -19 dB 5 -14 dB (default) 6 -9 dB 7 -4 dB 8 +4 dB 9 +9 dB 10 +14 dB

6.5.2. Notes

+VGR Receive Gain setting takes effect after reset or during the voice call.

+VGR parameter is automatically saved into non-volatile memory.

+VGR has no effect on the PCM bus.

6.6. +VGT Transmit Gain Selection

Description	Command	Possible Response(s)
Set transmit gain	+VGT=<n>	OK +CME ERROR: <err>
Get transmit gain	+VGT?	+VGT: <n> OK

Description	Command	Possible Response(s)
Get supported transmit gain	+VGT=?	+VGT: (list of supported <n>s) OK

6.6.1. Parameters

<n>	Description
1..10	Transmit gain: 1 -6 dB 2 -2 dB 3 0 dB 4 +2 dB 5 +6 dB 6 +12 dB 7 +18 dB (default) 8 +24 dB 9 +30 dB 10 +36 dB

6.6.2. Notes

Transmit gain setting takes effect after reset.

Transmit gain parameters are automatically saved into non-volatile memory.

+VGT has no effect on the PCM bus.

6.7. +WDGR Receive Digital Gain Selection

Description	Command	Possible Response(s)
Set the receive digital gain of the speakers/PCM	+WDGR=<Configuration>, <Rgain>	OK
Get the receive digital gain of the speakers/PCM	+WDGR?	+WDGR: <Configuration>, <Rgain> [+WDGR: <Configuration>, <Rgain>[...]] OK
Get supported voice parameters	+WDGR=?	+WDGR: (list of supported <Configuration>s), (list of supported <Rgain>s) OK

6.7.1. Parameters

<Configuration>	Description
1	DspRxOrgan for Speaker 1/Speaker 2
2	DspRxOrgan for PCM

<Rgain>	Description
0000-7FFF	Reception gain in Hexadecimal character format. See section 6.7.2 Gain Conversion for the conversion table. Default value for <Configuration>=1: 09EE Default value for <Configuration>=2: 13EE

6.7.2. Gain Conversion

Value in HEX	Gain in dB
0x0B51	-3dB
0x0CB3	-2dB
0x0E40	-1dB
0x1000	0dB
0x11F4	1dB
0x1425	2dB
0x1699	3dB
0x195C	4dB
0x1C74	5dB
0x1FF0	6dB
0x23D8	7dB
0x2836	8dB
0x2D1F	9dB
0x329A	10dB

6.7.3. Examples

Command	Responses
AT+WDGR=?	+WDGR: (1-2), (0000-7FFF) OK
AT+WDGR?	+WDGR: 1, "09EE" +WDGR: 2, "13EE" OK
AT+WDGR=1, "6F77"	OK

Command	Responses
AT+WDGR?	+WDGR: 1,"6F77" +WDGR: 2,"13EE" OK
AT+WDGR=0,"2F77"	ERROR
AT+WDGR=2,"2F77"	ERROR
AT+WDGR=1,"111V"	ERROR

6.7.4. Notes

The parameters are stored in non-volatile memory without using the AT&W command. The default value can be restored using AT&F.

Updated settings take effect on the next call.

6.8. +WDGT Transmit Digital Gain Selection

Description	Command	Possible Response(s)
Set the transmit digital gain of the microphone/PCM	+WDGT=<Configuration>,<Tgain>	OK
Get the transmit digital gain of the microphone/PCM	+WDGT?	+WDGT: <Configuration>,<Tgain> [+WDGT: <Configuration>,<Tgain>[...]] OK
Get supported voice parameters	+WDGT=?	+WDGT: (list of supported <Configuration>s), (list of supported <Tgain>s) OK

6.8.1. Parameters

<Configuration>	Description
1	DspTxOrgan for Speaker 1/Speaker 2
2	DspTxOrgan for PCM

<Tgain>	Description
0000-7FFF	Transmission gain in Hexadecimal character format. See section 6.7.2 Gain Conversion for the conversion table. Default value for <Configuration>=1: 0CEE Default value for <Configuration>=2: 09EE

6.8.2. Examples

Command	Responses
AT+WDGT=?	+WDGT: (1-2), (0000-7FFF) OK
AT+WDGT?	+WDGT: 1, "0CEE" +WDGT: 2, "09EE" OK
AT+WDGT=1, "1247"	OK
AT+WDGT?	+WDGT: 1, "1247" +WDGT: 2, "09EE" OK
AT+WDGT=0, "2F77"	ERROR
AT+WDGT=2, "2F77"	ERROR
AT+WDGT?	+WDGT: 1, "1247" +WDGT: 2, "09EE" OK
AT+WDGT=1, "8000"	ERROR
AT+WDGT?	+WDGT: 1, "1247" +WDGT: 2, "09EE" OK
AT+WDGT=1, "111P"	ERROR
AT+WDGT?	+WDGT: 1, "1247" +WDGT: 2, "09EE" OK

6.8.3. Notes

The parameters are stored in non-volatile memory without using the AT&W command. The default value can be restored using AT&F.

Updated settings take effect on the next call.

6.9. &T Audio Test

Description	Command	Possible Response(s)
Set audio loop	&T [n]	OK

6.9.1. Parameters

<n>	Description
0	Stop the audio loop
1	Execute the audio loop on Speaker 1
2	Execute the audio loop on Speaker 2
3	Execute the audio loop on PCM

6.9.2. Examples

Command	Responses
AT&T1 Note: start the audio loop on speaker 1	OK
AT&T3 Note: start the audio loop on PCM	OK
AT&T0 Note: stop the audio loop	OK

6.9.3. Notes

Audio loop mode must not be enabled when a communication is active.

Audio loop mode must not be enabled when a tone is under generation.

Audio loop must be disabled (if active) before opening a communication.

Tone generation and side tone modification must not be possible when the audio loop is active.

6.10. +VIP Initialize Voice Parameter

Description	Command	Possible Response(s)
Set voice parameter	+VIP=<n>	OK +CME ERROR: <err>
Get supported voice parameter	+VIP=?	+VIP: (list of supported <n>s) OK

6.10.1. Parameters

<n>	Description
0	Speaker 1
2	Speaker 2
23	PCM

6.10.2. Notes

The value of <n> is automatically reset after a call (returned to 0).

6.11. +WDTMF Play DTMF Tone

Description	Command	Possible Response(s)
Play (or stop playing) DTMF tone	+WDTMF=<mode>[,<dtmf>[, [<gain>] [,<duration>]]]	OK +CME ERROR: <err>
Get supported DTMF parameters	+WDTMF=?	+WDTMF: (list of supported <mode>s), (list of supported <dtmf>s), (list of supported <gain>s), (list of supported <duration>s) OK

6.11.1. Parameters

<mode>	Description
0	Stop playing a DTMF tone
1	Play a DTMF tone

<dtmf>	Description
0-9,*,#,A,B,C,D	DTMF to be played (mandatory if <mode>=1)

<gain>	Description
0-255	Tone gain. Default value if omitted: 10. Refer to section 6.11.2 Attenuation Values for more information.

<duration>	Description
0-255	Tone duration. Default value if omitted: 50. The tone can be stopped by AT+WDTMF=0.

6.11.2. Attenuation Values

Tone Gain	255	228	181	128	64	32	16	8	4	2	1	0
Attenuation	-0.03	-1	-3	-6	-12	-18	-24	-30	-36	-42	-48	-∞

6.11.3. Examples

Command	Responses
AT+WDTMF=?	+WDTMF: (0-1), (0-9, *, #, A, B, C, D), (0-255), (0-255) OK
AT+WDTMF?	ERROR
AT+WDTMF=1,"5",50,255 Note: Play dtmf#5 with gain 50 in (255*20ms) 5100msecs	OK
AT+WDTMF=0 Note: stop playing	OK

6.11.4. Notes

This command is available when the module has finished initializing.

>> 7. TIA578A Commands

7.1. General Commands

7.1.1. +FMI Manufacturer Identification

Description	Command	Possible Response(s)
Get manufacturer ID	+FMI	<manufacturer> OK
Test if command is supported	+FMI=?	OK

7.1.1.1. Parameters

<manufacturer>	Description
String type	Read manufacturer identification (SIERRA WIRELESS MODEM)

7.1.2. +FMM Model Identification

Description	Command	Possible Response(s)
Get model ID	+FMM	<model> OK
Test if command is supported	+FMM=?	OK

7.1.2.1. Parameters

<model>	Description
String type	Read model identification

7.1.3. +FMR Revision Identification

Description	Command	Possible Response(s)
Get revision ID	+FMR	<revision> OK
Test if command is supported	+FMR=?	OK

7.1.3.1. Parameters

<revision>	Description
String type	Read revision identification (L30_00gg.WS6318 <date>)

7.2. Capabilities Identification and Control

7.2.1. +FCLASS Model Identification

Description	Command	Possible Response(s)
Set class	+FCLASS=<class>	OK +CME ERROR: <err>
Get current class	+FCLASS?	+FCLASS: <class> OK
Get supported value	+FCLASS=?	+FCLASS: (list of supported <class>s) OK

7.2.1.1. Parameters

<class>	Description
0	Data mode
1	Fax class 1 (TIA-578-A) mode

7.2.2. +FTH HDLC Transmit

Description	Command	Possible Response(s)
Set mode	+FTH=<mode>	OK +CME ERROR: <err>
Get current mode	+FTH?	+FTH: <mode> OK
Get supported modes	+FTH=?	+FTH: (list of supported <mode>s) OK

7.2.2.1. Parameters

<mode>	Description
3	V21 channel 2300 bps

7.2.2.2. Notes

Set command is sent to ME only when link is online data mode.

This command is only relevant for in Fax mode.

7.2.3. +FRH HDLC Receive

Description	Command	Possible Response(s)
Set mode	+FRH=<mode>	OK +CME ERROR: <err>
Get current mode	+FRH?	+FRH: <mode> OK
Get supported modes	+FRH=?	+FRH: (list of supported <mode>s) OK

7.2.3.1. Parameters

<mode>	Description
3	V21 channel 2300 bps

7.2.3.2. Notes

Set command is sent to ME only when link is online data mode.

This command is only relevant in Fax mode.

7.2.4. +FTM Facsimile Transmit

Description	Command	Possible Response(s)
Set mode	+FTM=<mode>	OK +CME ERROR: <err>
Get current mode	+FTM?	+FTM: <mode> OK
Get supported modes	+FTM=?	+FTM: (list of supported <mode>s) OK

7.2.4.1. Parameters

<mode>	Description
24, 48, 72, 96	24 V27ter 2400 bps 48 V27ter 4800 bps 72 V29 7200 bps 96 V29 9600 bps

7.2.4.2. Notes

Set command is sent to ME only when link is online data mode.

9600 is always returned by read command because communication must begin at this speed.

7.2.5. +FRM Facsimile Receive

Description	Command	Possible Response(s)
Set mode	+FRM=<mode>	OK +CME ERROR: <err>
Get current mode	+FRM?	+FRM: <mode> OK
Get supported modes	+FRM=?	+FRM: (list of supported <mode>s) OK

7.2.5.1. Parameters

<mode>	Description
24, 48, 72, 96	24 V27ter 2400 bps 48 V27ter 4800 bps 72 V29 7200 bps 96 V29 9600 bps

7.2.5.2. Notes

Set command is sent to ME only when link is online data mode.

9600 is always returned by read command because communication must begin at this speed.



8. Proprietary AT Commands

8.1. Capabilities Identification and Control

8.1.1. #CLS Service Class

Description	Command	Possible Response(s)
Set class	#CLS=<class>	OK +CME ERROR: <err>
Get current class	#CLS?	#CLS: <class> OK
Get the current mode	#CLS=?	#CLS: (list of currently available <class>s) OK

8.1.1.1. Parameters

<class>	Description
0 (default)	Data mode
1	Fax class 1 (TIA-578-A) mode

8.1.1.2. Notes

This command has the same role and behaviour as +FCLASS command.

It is needed for Microsoft® agreement.

8.2. Flow Control Command

8.2.1. &R RTS/CTS option

Description	Command	Possible Response(s)
Set RTS/CTS option	&R<option>	OK ERROR

8.2.1.1. Parameters

<option>	Description
1 (default)	In sync mode, CTS is always ON (RTS transitions are ignored). In async mode, CTS will only drop if required by the flow control.

8.2.1.2. Notes

This command selects how the modem controls CTS. CTS operation is modified if hardware flow control is selected; hardware flow control is supported as of Firmware version L20.

&R parameter is saved into non-volatile memory by AT&W command and restored to default value by AT&F command.

8.3. Manufacturer Tests Command

8.3.1. +CPOF Power off

Description	Command	Possible Response(s)
Switch off mobile	+CPOF	OK

8.3.1.1. Description

This command allows switching off the mobile. Note that "OK" result code will appear immediately if the command is accepted and power off will occur after that. Unexpected random characters may also be issued during switch off of MS.

8.3.2. *PSSURC Supplementary Services notification

Description	Command	Possible Response(s)
Set mode	*PSSURC=<mode>	OK +CME ERROR: <err>
Get current mode	*PSSURC?	*PSSURC: <mode> OK
Get supported modes	*PSSURC=?	*PSSURC: (list of supported <mode>s) OK

8.3.2.1. Description

This command is to configure the AT interface to give additional information through result code to TE when D command is entered with a SS string as parameter.

When <mode> parameter is enabled one or several intermediate result code are sent to provide additional information on SS operation.

8.3.2.2. Result Code

Description	Result Code
Successful SS operation	*PSSSURC: <SsCode>[,<BasicServiceCode>,<SsStatus>,<no_reply_cond_timer>,<ccbs_index>,<phone_number_ton_npi>,<phone_number_config>,<phone_number>,<sub_address_type>,<sub_address_authority_and_format_identifie>,<sub_address_data>[,<clir_option>]]
SS operation failure	*PSSSEERR:<cause_select>,<cause>

One intermediate result code per <service code> is sent.

8.3.2.3. Parameters

<mode>	Description
0 (default)	Disable sending of additional result code
1	Enable sending of additional result code

8.3.2.4. Notes

Example: CFU interrogation for telephony service

ATD*#21*11#

*PSSSURC: 33,11,0,255,,129,0,,1,2,,1

OK

Ss_code = 33 → SPS_SC_CFU

BasicServicecode = 11 → SPS_BS_TELEPHONY

SsStatus = 0 → SPS_STATUS_DEACTIVATED

8.3.3. +PSSLEEP Power Management Control

Description	Command	Possible Response(s)
Set sleep mode	+PSSLEEP=<mode> [, <seconds>]	OK +CME ERROR: <err>
Get current sleep mode	+PSSLEEP?	+PSSLEEP: <mode>, <seconds> OK
Get supported sleep modes	+PSSLEEP=?	+PSSLEEP: (list of supported <mode>s), (list of supported <seconds>s) OK

8.3.3.1. Parameters

<mode>	Description
0,1	0: The module doesn't go in sleep mode as long as DTR is set to high level (default value) 1: The module decides by itself (internal timing) when it goes in sleep mode

<seconds>	Description
1 – 60	Delay time in seconds. When mode 1 is selected, if a <seconds> value is provided, the module will go in sleep mode after <seconds> of non-activity on the UART bus.

8.3.3.2. Notes

Action command sets sleep mode for MT. If the command fails in an MT error, +CME ERROR: <err> is returned. Test command returns supported values.

In <mode>=1, any character sent on the UART will wake the system up, and then AT commands can be input normally. The module can also be woken up by asserting DTR or by a TX BREAK signal on the UART.

Also, in <mode>=1, if receive flow-control is enabled (+IFC=2,2), RTS should be active (low signal) to allow the module to enter sleep mode. With this configuration, if receive flow is off (RTS is inactive) while there is buffered AT transmit data in the UART, the module will not enter sleep mode.

When the module is sleeping, it will set CTS to low.

+PSSLEEP parameter is saved into non-volatile memory by AT&W command. Default values are not restored by AT&F command.

8.4. SIM Toolkit Command and Result Codes

8.4.1. *PSSTKI SIM Toolkit Interface Configuration

Description	Command	Possible Response(s)
Set mode	*PSSTKI=<mode>	OK +CME ERROR: <err>
Get current mode	*PSSTKI?	*PSSTKI: <mode> OK +CME ERROR: <err>
Get supported modes	*PSSTKI=?	*PSSTKI: (list of supported <mode>s) OK +CME ERROR: <err>

8.4.1.1. Description

This command is to configure SIM toolkit by AT command.

8.4.1.2. Parameters

<mode>	Description
0	STK by AT command is deactivated, only ME's MMI will receive SIM toolkit notifications
1	STK by AT command is activated: SIM toolkit notification will first be sent to AT parser. If an AT channel is connected, *PSSTK URC will be sent, *PSSTK AT command has to be used to respond. If no AT channel is connected: ME's MMI will receive the notification
2 (default)	APPI_STK_xxx_RSP is automatically sent. *PSSTK URC is sent to AT user.
3	APPI_ATK_xxx_RSP is automatically sent.

8.4.1.3. Notes

The AUTO-ACK mechanism is only possible for a subset of STK commands with user interaction.

AUTO-ACK is possible:

- Where basic Yes/No responses are expected:
 - SEND SHORT MESSAGE
 - SEND SS
 - SEND USSD
 - SETUP CALL

- Where MMI action is needed and Yes/No responses are expected when done (for the display part):
 - SETUP MENU
 - REMOVE MENU
 - SETUP IDLE MODE TEXT
 - DISPLAY TEXT
 - PLAY TONE

8.4.2. *PSSTK SIM Toolkit Control

*PSSTK command is defined to support SIM toolkit by AT commands. Only part of SIM toolkit commands that interact with user or MMI can be controlled.

All other SIM toolkit mechanism such as terminal profile, SMS or CBM data download, call control or MO SMS control by SIM, event download and all command that does not require interaction with the user (or screen) are internally managed by the ME.

This command is implemented in ATCUST module and can be updated/modified.

8.4.2.1. Notification from SIM to User: PSSTK Unsolicited Result Code

Description	Result Code
Notification from SIM to user	*PSSTK: <notification type>, <parameter1>, ..., <parameterN>

8.4.2.2. Parameters

<notification type>	Description
	A string that represents the type of notification (proactive command name) received from the SIM. Some command requires the use of *PSSTK set command to send a response to the SIM.
LANGUAGE NOTIFICATION	Sent on reception of APPI_STK_LANGUAGE_NOTIFICATION_IND
CONTROL BY SIM	Sent on reception of APPI_STK_CONTROL_BY_SIM_IND
REFRESH	Sent on reception of APPI_STK_REFRESH_IND
END CALL	Sent on reception of APPI_STK_END_CALL_IND
DISCONNECT	Sent on reception of APPI_CALL_ASYNC_DISCONNECT_IND
PROCESSING	Sent on reception of APPI_STK_PROCESSING_IND
END SESSION	Sent on reception of APPI_STK_END_SESSION_IND
ABORT SESSION	Sent on reception of APPI_STK_ABORT_SESSION_IND
NOTIFICATION	Sent on reception of APPI_STK_NOTIFICATION_IND Require use of *PSSTK set command to respond to SIM
SETUP CALL	Sent on reception of APPI_STK_SETUP_CALL_IND Require use of *PSSTK set command to respond to SIM
DISPLAY TEXT	Sent on reception of APPI_STK_DISPLAY_TEXT_IND Require use of *PSSTK set command to respond to SIM

<notification type>	Description
GET INKEY	Sent on reception of APPI_STK_GET_INKEY_IND Require use of *PSSTK set command to respond to SIM
GET INPUT	Sent on reception of APPI_STK_GET_INPUT_IND Require use of *PSSTK set command to respond to SIM
PLAY TONE	Sent on reception of APPI_STK_PLAY_TONE_IND Require use of *PSSTK set command to respond to SIM
SELECT ITEM	Sent on reception of APPI_STK_SELECT_ITEM_IND Require use of *PSSTK set command to respond to SIM
SETUP MENU	
REMOVE MENU	Sent on reception of APPI_STK_REMOVE_MENU_IND Require use of *PSSTK set command to respond to SIM
SETUP IDLE MODE TEXT	Sent on reception of APPI_STK_SET_UP_IDLE_MODE_TEXT_IND Require use of *PSSTK set command to respond to SIM

<parameteri>	Description
Integer or string type	Number of parameters in URC depends of the message.

8.4.2.3. Response from User to SIM: *PSSTK Command

Description	Command	Possible Response(s)
Respond to SIM	*PSSTK=<reponse type>, <parameter1>, ..., <parameterN>	OK +CME ERROR: <err>
Get supported response type	*PSSTK=?	*PSSTKI: (list of supported <response type>s) OK +CME ERROR: <err>

8.4.2.4. Parameters

<response type>	Description
	A string that represents the type of response to be sent to SIM (terminal response or envelope). Some response correspond to answer to *PSSTK URC.
MENU SELECTION	Send a APPI_STK_MENU_SELECTION_REQ (On reception of APPI_STK_MENU_SELECTION_CNF, OK is sent)
GET ITEM LIST	Call macro MC_STK_FIRST_ITEM and MC_STK_NEXT_ITEM to get the information of the last received SET UP MENU or SELECT ITEM command.
ALL CALLS DISCONNECTED	Send a APPI_STK_ALL_DISCONNECTED_REQ
USER ACTIVITY	Send a APPI_STK_USER_ACTIVITY_IND
IDLE SCREEN AVAILABLE	Send a APPI_STK_IDLE_SCREEN_AVAILABLE_IND

<response type>	Description
SETUP CALL TERMINATED	Send a APPI_STK_SETUP_CALL_TERMINATED_REQ
COMMAND REJECTED	Send a APPI_STK_COMMAND_RJT. Used to reject any URC that requires a response.
NOTIFICATION	Send a APPI_STK_NOTIFICATION_RSP
SETUP CALL	Send a APPI_STK_SETUP_CALL_RSP
DISPLAY TEXT	Send a APPI_STK_DISPLAY_TEXT_RSP
GET INKEY	Send a APPI_STK_GET_INKEY_RSP
GET INPUT	Send a APPI_STK_GET_INPUT_RSP
PLAY TONE	Send a APPI_STK_PLAY_TONE_RSP
SELECT ITEM	Send a APPI_STK_SELECT_ITEM_RSP
SETUP MENU	Send a APPI_STK_SETUP_MENU_RSP
REMOVE MENU	Send a APPI_STK_REMOVE_MENU_RSP
SETUP IDLE MODE TEXT	Send a APPI_STK_SET_UP_IDLE_MODE_TEXT_RSP

<parameteri>	Description
Integer or string type	Number of parameters in URC depends of message.

8.4.2.5. Use Case

```

TE (PC)                                     ME
|                                             |
| <---- *PSSTK: "DISPLAY TEXT",... ----> | <- unsolicited result code
|                                             | received from SIM ToolKit
| ---- *PSSTK: "DISPLAY TEXT",... ----> | <- answer to an unsolicited
|                                             | result code
| <-----> OK -----> | <- AT command result
    
```

8.5. CPHS Proprietary Commands

8.5.1. *PSVMWN Voice Message Waiting Notification

Description	Command	Possible Response(s)
Set mode	*PSVMWN=<mode>	OK +CME ERROR: <err>
Get current mode	*PSVMWN?	*PSVMWN: <mode> OK +CME ERROR: <err>
Get supported modes	*PSVMWN =?	*PSVMWN: (list of supported <mode>s) OK +CME ERROR: <err>

8.5.1.1. Description

Set command enables/disables the presentation of notification result code from ME to TE

When <mode>=1, a Voice Message Waiting Indication (*PSVMWI) is sent to TE when notification is received (special SMS) from network or at switch on.

Description	Result Code
Voice Message Waiting Indication	*PSVMWI: <line Id>,<status>[,<index>[,<NbMsgWaiting>]]

8.5.1.2. Parameters

<mode>	Description
0	Disable presentation of notification
1	Enable presentation of notification

<line Id>	Description
1	Line 1
2	Line 2 (Auxiliary line)
3	Data
4	Fax

<status>	Description
0	No message waiting

<status>	Description
1	At least one message is waiting

<index>	Description
0..255	Record index in EF SMS if the received MWI message has been stored in SIM

<NbMsgWaiting>	Description
0..255	Number of message waiting on <line id>

8.5.2. *PSALS Alternate Line Service

Description	Command	Possible Response(s)
Select line for MO speech call	*PSALS=<Line Id>	OK +CME ERROR: <err>
Get current line	*PSALS?	*PSALS: <line Id> OK +CME ERROR: <err>
Get supported lines	*PSALS =?	*PSALS: (list of supported <line Id>) OK +CME ERROR: <err>

8.5.2.1. Description

Set command is used to select the line to be used for MO speech calls.

For MT (speech) calls, +CRING URC (refer +CRC command) indicates on which line the call is receive (+CRING: VOICE → default case = line 1, +CRING: VOICE_AUX → line 2.)

<line Id>	Description
1 (default)	Line 1
2	Line 2 (Auxiliary line)

8.5.3. *PSDCIN Diverted Call Indicator Notification

Description	Command	Possible Response(s)
Set mode	*PSDCIN=<mode>[,<line Id>]	[*PSDCIN: <line Id>,<status> [[...] <CR><LF>*PSDCIN: <line Id>,<status>]] OK +CME ERROR: <err>
Get current mode	*PSDCIN?	*PSDCIN: <mode> OK +CME ERROR: <err>
Get supported values	*PSDCIN=?	*PSDCIN: (list of supported <modes>), (list of supported <line Id>s)

8.5.3.1. Description

Set command enables/disables the presentation of a Diverted Call Indication (also known as CFU) result code from ME to TE.

When <mode>=2, status of <line Id> is requested. If <line Id> is not provided, query is requested for all lines.

When <mode>=1, Diverted Call Indication *PSDCI is sent to TE on reception of network notification. (Several result codes can be sent at the same time on reception of the notification).

Description	Result Code
Diverted Call Indication	*PSDCI: <line Id>,<status>

8.5.3.2. Parameters

<mode>	Description
0	Disabled CFU notification presentation
1	Enabled CFU notification presentation
2	Query CFU status

<line Id>	Description
1	Line 1
2	Line 2 (Auxiliary line)
3	Data
4	Fax

<status>	Description
0	Not active
1	Active

8.5.3.3. Notes

The status of <line Id> is only requested when <mode> = 2. The <line Id> parameter is not needed when <mode> = 0 or 1. When <line Id> is specified when <mode> = 0 or 1, Error will be returned.

8.5.4. *PSMBNB Mailbox Number

Description	Command	Possible Response(s)
Set mailbox number in SIM	*PSMBNB=<line Id>[,<number>,<type>[,<text>]]	OK +CME ERROR: <err>
Read mailbox numbers	*PSMBNB?	[*PSMBNB: <line Id>,<number>,<type>,<text> [[...] <CR><LF>*PSMBNB: <line Id>,<number>,<type>,<text>]] OK +CME ERROR: <err>
Get supported values	*PSMBNB=?	*PSMBNB: (list of supported <line Id>), (list of supported <type>)[,<nlength>][,<tlength>]

8.5.4.1. Description

The purpose of this command is not to replace +CSVM command but to offer more possibilities for Mailbox numbers settings (+CSVM command allows only voice mailbox settings, CPHS define one record per line).

Set command writes the mailbox number for <line id> in SIM.

If only <Line Id> is present in command, corresponding record is deleted in SIM.

8.5.4.2. Parameters

<line Id>	Description
1	Line 1
2	Line 2 (Auxiliary line)
3	Data
4	Fax

<number>	Description
String type	Phone number of format <type>

<type>	Description
Integer type	Type of address (refer GSM 04.08 [8] subclause 10.5.4.7) ; default 145 when dialling string includes international access code character "+", otherwise 129

<text>	Description
String type	Field of maximum length <tlength> Character set as specified by +CSCS

<nlength>	Description
Integer type	Value indicating the maximum length of field <number>

<tlength>	Description
Integer type	Value indicating the maximum length of field <text>

8.5.5. *PSCSP Customer Service Profile

Description	Command	Possible Response(s)
Set command	*PSCSP	OK +CME ERROR: <err>
Read CSP	*PSCSP?	[*PSCSP: <service group code>, <status> [[...]<CR><LF>*PSCSP: <service group code>, <status>]] +CME ERROR: <err>
Get supported values	*PSCSP=?	* PSCSP: (list of supported <service group code>s) OK +CME ERROR: <err>

8.5.5.1. Description

Command used to read the CSP file in SIM.
Set command has no effect (OK returned).

8.5.5.2. Parameters

<service group code>	Description
String type	Hexadecimal representation of a coding group as defined in CPHS recommendation (“01”..”09”, “C0”, “D5”)

<status>	Description
String type	Bit field representation of each element of a service group (ex: "11000000")

8.5.6. +PACSP Customer Service Profile Query by ME

Description	Command	Possible Response(s)
Read command	AT+PACSP?	+PACSP: <status> OK
Test command	AT+PACSP=?	(none)
Unsolicited response		+PACSP: <status> Note: Unsolicited response returned when power up if SIM with EF-CSP; no unsolicited response if SIM does not have EF-CSP.

8.5.6.1. Description

This command allows the ME to query the statue of Customer Service Profile in SIM (EF-CSP).

8.5.6.2. Parameters

<status>	Description
0	SIM with CSP disable
1	SIM with CSP enable

8.5.6.3. Examples

Command	Possible Responses
AT+PACSP? Note: Query EF-CSP status	+PACSP: 1 OK Note: Current EF-CSP status
	+PACSP: 1 Note: Unsolicited response once SIM initialized

8.5.6.4. Notes

This command is available when the SIM has finished its initialization.

8.5.7. *PSINFN Information Number

Description	Command	Possible Response(s)
Get information number entries	*PSINFN=<index1>[,<index2>]	[*PSINFN: <index1>,<number>,<type>,<text>,<Net Id>,<Prem Id>,<Level> [[...]<CR><LF>*PSINFN: <index2>,<number>,<type>,<text>,<Net Id>,<Prem Id>,<Level>] OK +CME ERROR: <err>
Read command	*PSINFN	OK +CME ERROR: <err>
Get supported values	*PSINFN=?	*PSINFN: (list of supported <index>s) [,<nlength>] [,<tlength>] OK +CME ERROR: <err>

8.5.7.1. Description

Set command returns phonebook entries in location number range <index1>... <index2> from Information Number SIM file. If <index2> is left empty, only location <index1> is returned. If all queried locations are empty (but available), no information text lines may be returned (only an OK is returned). If listing fails in a ME error, +CME ERROR: <err> is returned.

Read command has no effect (returns OK).

Information number shall only be presented to TE if field InformationsNumbers of CSP file is 0xFF, use AT*PSCSP? to check Service Group D5. Otherwise +CME ERROR: <err> is returned.

8.5.7.2. Parameters

<index>	Description
<index1>	
<index2>	
0..255	Index of information number phonebook entry

<number>	Description
String type	Phone number of format <type>

<type>	Description
Integer type	Type of address

<text>	Description
String type	Field of maximum length <tlength> Character set as specified by +CSCS

<Net Id>	Description
Integer type	Representation of the Network specific indicator

<Prem Id>	Description
Integer type	Representation of Premium service indicator

<Level>	Description
Integer type	Representation of the level of the record (in the tree)

<nlength>	Description
Integer type	Value indicating the maximum length of field <number>

<tlength>	Description
Integer type	Value indicating the maximum length of field <text>

8.6. General Purpose Proprietary Commands

8.6.1. *PSPRAS Pin Remaining Attempt Status

Description	Command	Possible Response(s)
Set command	*PSPRAS	OK ERROR
Get remaining PIN attempts	*PSPRAS?	*PSPRAS: <pin1>, <puk1>, <pin2>, <puk2> OK ERROR
Get supported codes	*PSPRAS=?	*PSPRAS: (list of supported <code>s) OK ERROR

8.6.1.1. Description

This command is used to get the number of remaining PIN and PUK attempts.
Set command has no effect (returns OK).

8.6.1.2. Parameters

<pin1>	Description
0..3	Number of remaining attempts for PIN 1

<pin2>	Description
0..3	Number of remaining attempts for PIN 2

<puk1>	Description
0..10	Number of remaining attempts for PUK 1

<puk2>	Description
0..10	Number of remaining attempts for PUK 2

<code>	Description
SIM PIN1	PIN 1 identifier

<code>	Description
SIM PIN2	PIN 2 identifier
SIM PUK1	PUK 1 identifier
SIM PUK2	PUK 2 identifier

8.6.2. *PSSEAV Service Availability

Description	Command	Possible Response(s)
Set mode	*PSSEAV=<mode>	OK +CME ERROR: <err>
Get current mode	*PSSEAV?	*PSSEAV: <mode> [<CR><LF>*PSREADY: <service>] [[...]<CR><LF>*PSREADY: <service>] OK +CME ERROR: <err>
Get supported modes	*PSSEAV=?	*PSSEAV: (list of supported <mode>s), (list of supported <service>s) OK +CME ERROR: <err>

8.6.2.1. Description

Set command enables/disables the presentation of notification result code from ME to TE. When <mode>=1, *PSREADY result code is sent to TE when <service> is available.

Read command is used to get current mode and to check which service are already available (*PSREADY is returned only for available services).

Description	Result Code
Service ready	*PSREADY: <service>

8.6.2.2. Parameters

<mode>	Description
0	Disable notification presentation
1	Enable notification presentation

<service>	Description
0	Phone book service availability
1	SMS service availability
2	CBM service availability

8.6.2.3. Notes

If a service becomes available before any AT channel is connected, *PSREADY notification will be buffered and sent as soon as the first AT channel connects.

8.6.3. +PSSREP Mobile Start-Up Reporting

Description	Command	Possible Response(s)
Set mode	+PSSREP=<act>	OK +CME ERROR: <err>
Get current mode	+PSSREP?	+PSSREP: <act>,<stat> OK
Get supported modes	+PSSREP=?	+PSSREP: (list of supported <act>s) OK

8.6.3.1. Parameters

<act>	Description
0 or 1	Indicates if the module must send an unsolicited code during the startup. 0: The module doesn't send an unsolicited code (default value) 1: The module will send an unsolicited code +PSSUP

<stat>	Description
0 or 1	This code indicates the status of the module. 0: The module is ready to receive commands for the TE. No access code is required 1: The module is waiting for an access code. (The AT+CPIN? command can be used to determine it) 2: The SIM card is not present 3: The module is in "SIMlock" state 4: unrecoverable error 5: unknown state

8.6.3.2. Notes

The module sends the unsolicited code once after the boot process +PSSUP: <stat>

The PSSUP notification will not be sent if the module is in autobaud mode and no bytes have been received from TE to adapt the serial link to the actual speed.

If the command fails in an MT error, +CME ERROR: <err> is returned. Test command returns supported values.

+PSSREP parameter is automatically saved into non-volatile memory.

The <act> parameter is restored to default value by AT&F command.

8.6.4. *PSCHRU Channel Registration URC

Description	Command	Possible Response(s)
Set URC filter	*PSCHRU=<mask>	OK +CME ERROR: <err>
Get current channel filter	*PSCHRU?	*PSCHRU: <mask> OK +CME ERROR: <err>
Get supported masks	*PSCHRU=?	*PSCHRU: (list of supported <mask>s) OK +CME ERROR: <err>

8.6.4.1. Description

Set command is used to filter one or several type of URC on a channel. By default all URC types are enabled on a newly opened channel.

This command only applies on the channel it is submitted, other channels are not impacted. Depending of <mask> value, URC will or will not be broadcasted on the channel.

8.6.4.2. Parameters

<mask>	Description
0	No URC sent on the channel
1	Call related URC to be sent on the channel: RING, +CRING, +CCCM, +CCWV, +CCWA, +CLIP, +COLP, +CSSI, +CSSU, *PSCALL, *PSDCI, *PSCSC, *PSCN
2	SMS related URC to be sent on the channel: +CDS, +CMT, +CMTI
4	CBM related URC to be sent on the channel: +CBM

<mask>	Description
8	ME status related URC to be sent on the channel: +CIEV
16	Network registration related URC to be sent on the channel: +CREG, +CGREG
32	SS related URC to be sent on the channel: +CUSD
64	Initialization related URC to be sent on the channel: *PSREADY
128	Debug related URC to be sent on the channel.
256	SIM toolkit related URC to be sent on the channel: *PSSTK

8.6.4.3. Notes

To enable the display of URC SMS (2) and CALL (1) and to forbid the display of the others on a channel, choose 2 and 1 parameter, i.e. send:

```
AT*PSCHRU=3
```

OK

8.6.5. *PSUTTZ Universal Time and Time Zone

Description	Command	Possible Response(s)
Set time zone notification mode	*PSUTTZ=<mode>	OK +CME ERROR: <err>
Get current mode	*PSUTTZ?	*PSUTTZ: <mode> OK +CME ERROR: <err>
Get supported modes	*PSUTTZ=?	*PSUTTZ: (list of supported <mode>s)

8.6.5.1. Description

Set command is used to enable or disable the display of universal time and time zone changes.

Description	Result Code
Universal time and time zone change notification	*PSUTTZ: <year>, <month>, <day>, <hour>, <minute>, <second>, <timezone>, <daylightsaving>

8.6.5.2. Parameters

<mode>	Description
0	Disable time zone indication
1	Enable time zone indication

<year>	Description
Integer type	UT year

<month>	Description
1..12	UT month

<day>	Description
1..31	UT day

<hour>	Description
0..23	UT hour

<minute>	Description
0..59	UT minute

<second>	Description
0..59	UT second

<timezone>	Description
String type	String representing time zone: Range: "-128".."0".." +127"

<daylightsaving>	Description
0..2	Daylight saving

8.6.6. *PSPNNU EONS: PNN Notification

Description	Command	Possible Response(s)
Select PNN notification mode	*PSPNNU=<mode>	OK +CME ERROR: <err>
Get the current PNN notification mode	*PSPNNU?	PSPNNU: <mode> OK +CME ERROR: <err>
Get supported modes	*PSPNNU=?	*PSPNNU: (list of supported <mode>s) OK +CME ERROR: <err>

8.6.6.1. Description

Set command enables or disables the presentation of PNN notification each time the registration state changes.

Description	Result Code
PNN Notification	*PSPNNU: <PLMNName>

8.6.6.2. Parameter

<mode>	Description
0	Disable presentation of notification
1	Enable presentation of notification

8.6.7. *PSPNNR EONS: PNN Display

Description	Command	Possible Response(s)
Get PNN	*PSPNNR=<MCC> , <MNC> [, LAC]	*PSPNN: <PLMNName> OK +CME ERROR: <err>
Test if command is supported	*PSPNNR=?	OK +CME ERROR: <err>

8.6.7.1. Description

Set command is used to display the PNN (PLMN Network Name) name.

8.6.7.2. Parameter

<MCC>	Description
String type	Mobile country code in numeric format (e.g. "208")

<MNC>	Description
String type	Mobile network code in numeric format (e.g. "10")

<LAC>	Description
String type	Location area code in numeric format

<PLMNName>	Description
String type	PLMN name in alphanumeric format

8.6.8. *PSAHPLMN Read AHPLMN

Description	Command	Possible Response(s)
Get AHPLMN information	*PSAHPLMN?	*PSAHPLMN: <MCC>, <MNC> OK +CME ERROR: <err>

8.6.8.1. Description

Read command reads the AHPLMN (Active Home PLMN).

8.6.8.2. Parameters

<MCC>	Description
Integer type	Mobile country code in numeric format (e.g. "208")

<MNC>	Description
Integer type	Mobile network code in numeric format (e.g. "10")

8.6.9. +PSTAT Tool Detection Enable

Description	Command	Possible Response(s)
Trig restart with tool detection	+PSTAT=<param>	+CME ERROR: <err>

8.6.9.1. Parameters

<param>	Description
Integer type	Useless parameter (any 2-digit number)

8.6.9.2. Notes

The set command enables the tool presence detection by the module and provokes an intended watchdog reset.

When restarting after the watchdog reset, the module sends 'I' (0x49) on UART to enquire for a tool.

Further reboots (intended or not) does not provoke tool detection procedure.

This AT command is only for TAT to reset the module so no OK response is needed. After successfully sending the command, no OK response is given and the module will reset immediately.

8.6.10. *PSRDBS Radio Band Settings

Description	Command	Possible Response(s)
Set radio bands	*PSRDBS=<mode> [,<GSM band>]	OK +CME ERROR: <err>
Get current values	*PSRDBS?	*PSRDBS: <GSM band> OK
Get supported values	*PSRDBS=?	*PSRDBS: (list of supported <mode>s), (list of supported <GSM band>s) OK

8.6.10.1. Description

Set command is used to set the radio band(s).

When <mode>=0, band settings are taken into account only at next switch on. However, the read command will display the band settings to be applied after next switch on.

When <mode>=1, a stack restart is performed to select immediately the requested settings.

8.6.10.2. Parameters

<mode>	Description
0	Set radio bands, will be taken into account at next switch on
1	Set radio bands, a stack restart is performed to take into account the new selected bands

<GSM band>	Description
2	GSM 900
4 (default)	E-GSM
8 (default)	DCS 1800

Note: Bit field type parameter; to set several bands, sum up the values.

8.6.10.3. Notes

Example:

To set GSM 900 & DCS 1800:

```
AT*PSRDBS=1,10
```

```
OK
```

To set E-GSM and DCS 1800:

```
AT*PSRDBS?
```

```
*PSRDBS: 4
```

```
OK
```

```
AT*PSRDBS=0,12
```

```
OK
```

```
AT*PSRDBS?
```

```
*PSRDBS: 12
```

```
OK
```

With <mode>=0, "12" will only take effect after the module reboots. Note that the current registered band would still be "4" and that the read command will only display the new band setting after the module has rebooted.

*PSRDBS parameters are automatically saved into non-volatile memory.

8.6.11. *PSADC A/D Convert Info

Description	Command	Possible Response(s)
Read A/D value	*PSADC=<Adc>,<MeasTime>	*PSADC:<AdcValue>,<Adc>,<MeasTime>,<TxPower> OK+CME ERROR: <err>
Get supported values	*PSADC=?	+PSADC:(list of supported <ADC>s), (list of supported <MeasTime>s) OK

8.6.11.1. Description

This command will return AdcValue, RequestedAdc, MeasTime, and BurstPower.

8.6.11.2. Parameters

<Adc>	Description
0	Battery voltage (Vbatt)
3	Reserved
4	Auxilliary ADC (AUX_ADC0)
5	Auxilliary ADC (AUX_ADC1)

<MeasTime>	Description
1	During transmit burst
2	Outside transmit burst
3	No constraint on transmit burst

<AdcValue>	Description
Integer	Voltage value read by ADC

<TxPower>	Description
Integer	Tx power value applied during Tx burst if <MeasTime>=1, otherwise 0

8.6.12. +PSRIC RI Behaviour

Description	Command	Possible Response(s)
Set RI behaviour	+PSRIC=<RImask>,<RIshape>	OK +CME ERROR: <err>
Get RI behaviour	+PSRIC?	+PSRIC: <RImask>,<RIshape> OK +CME ERROR: <err>
Get supported values	+PSRIC=?	+PSRIC: (list of supported <RImask>s), (list of supported <RIshape>s) OK +CME ERROR: <err>

8.6.12.1. Description

This command sets the Ring Indicator (RI) behaviour.

8.6.12.2. Parameters

<RImask>	Description
0	No RI indication
1	RI indication on incoming calls
2	RI indication on SMS reception
4	RI indication on Cell Broadcast Messages (CBM) reception
8	RI indication on Supplementary Service (SS) reception
16	RI indication on +CIEV event reception
31	All values

Note: Bit field type parameter; to set several RI conditions, sum up the values.

<RIshape>	Description
0	RI is indicated by a low pulse
1	RI is indicated by a continuous low level

8.6.13. +WMGPIO GPIO Access

Description	Command	Possible Response(s)
Set GPIO access	+WMGPIO=<IO>,<cde>	if <cde>=2 +WMGPIO: <IO>,<status> OK else OK +CME ERROR: <err>
Get GPIO access	+WMGPIO?	+WMGPIO: 1,<status> +WMGPIO: 2,<status> +WMGPIO: 4,<status> +WMGPIO: 5,<status> +WMGPIO: 6,<status> +WMGPIO: 7,<status> +WMGPIO: 8,<status> +WMGPIO: 9,<status> +WMGPIO: 10,<status> +WMGPIO: 11,<status> +WMGPIO: 12,<status> OK
Get supported GPIO access	+WMGPIO=?	+WMGPIO: (1,2,4,5,6,7,8,9,10,11,12),(0,1,2) OK

8.6.13.1. Description

This command allows reading or writing of a GPIO's status.

8.6.13.2. Parameters

<IO>	Description
1, 2, 5-12	GPIO
4	GPI

<cde>	Description
0	Set the selected GPIO to logic low
1	Set the selected GPIO to logic high
2	Request the high/low status of the selected GPIO

<status>	Description
0	The read status of the selected GPIO is logic low
1	The read status of the selected GPIO is logic high

8.6.13.3. Notes

GPIO configuration is not stored in memory. The current configuration is lost with a reset. Be aware that this command doesn't change the reset state of the GPIO.

8.6.14. +WMGPIOCFG GPIO Configuration

Description	Command	Possible Response(s)
Set GPIO configuration	+WMGPIOCFG=<IO>,<dir>,<pull mode>	OK +CME ERROR: <err>
Get GPIO configuration	+WMGPIOCFG?	+WMGPIOCFG: 1,<dir>,<pull> +WMGPIOCFG: 2,<dir>,<pull> +WMGPIOCFG: 4,<dir>,<pull> +WMGPIOCFG: 5,<dir>,<pull> +WMGPIOCFG: 6,<dir>,<pull> +WMGPIOCFG: 7,<dir>,<pull> +WMGPIOCFG: 8,<dir>,<pull> +WMGPIOCFG: 9,<dir>,<pull> +WMGPIOCFG: 10,<dir>,<pull> +WMGPIOCFG: 11,<dir>,<pull> +WMGPIOCFG: 12,<dir>,<pull> OK
Get supported GPIO configuration	+WMGPIOCFG=?	+WMGPIOCFG: (1,2,4,5,6,7,8,9,10,11,12),(0,1), (0,1,2) OK

8.6.14.1. Description

This command allows the configuration of a GPIO.

8.6.14.2. Parameters

<IO>	Description
1, 2, 5-12	GPIO
4	GPI

<dir>	Description
0	The selected GPIO is configured as an output pin
1	The selected GPIO is configured as an input pin

<pull mode>	Description
0	Pull down
1	Pull up
2	No pull

8.6.14.3. Notes

The GPIO configuration is not stored in memory. The current configuration is lost with a reset.

If GPIO set as output, user cannot select pull mode as “no pull”.

When a GPIO output pin is configured with pull-down, it will be set to logic low after the +WMPWMIOCFG configuration. Otherwise, it will be set to logic high.

8.6.15. +WMPWM PWM and Buzzer Configuration

Description	Command	Possible Response(s)
Set PWM configuration	+WMPWM=<output>,<operation>,[<period>],[<dutycycle>]	OK +CME ERROR: <err>
Get PWM configuration	+ WMPWM?	+WMPWM:<output>,<operation>,<period>,<dutycycle> [+WMPWM:<output>,<operation>,<period>,<dutycycle> ...] OK

Description	Command	Possible Response(s)
Get supported PWM configuration	+ WMPWM=?	+WMPWM:(list of supported <output>s), (list of supported <operation>s), (list of supported <period>s), (list of supported <dutycycle>s) [+WMPWM:(list of supported <output>s), (list of supported <operation>s), (list of supported <period>s), (list of supported <dutycycle>s) [...]] OK

8.6.15.1. Description

This command allows setting PWM or buzzer configuration.

8.6.15.2. Parameters

<output>	Description
0	PWM0
1	PWM1
2	Buzzer

<operation>	Description
0	Turn off
1	Turn on
2	Always high level

<period>	Description
0, 2 ... 126 (when <output> is PWM0 or PWM1)	0: PWM is always at low level 2 ... 126: PWM period as in: (<period>+1) / 3.25MHz (Example: <period>=2, PWM period=3/3.25MHz=923ns, PWM frequency=1.083MHz <period>=126, PWM period=127/3.25MHz=39.08µs, PWM frequency=25.6kHz)
0 ... 1023 (when <output> is buzzer)	Buzzer period as in: (<period>+1) / 250000 (Example: <period>=0, buzzer period=1/250000=4µs, buzzer frequency=250kHz <period>=1023, buzzer period=1024/250000=4.1ms, buzzer frequency=244.14Hz)

<dutycycle>	Description
0 ... 100	Duty cycle percentage for PWM0 and PWM1 (0=always low, 100=always high) Tone level for buzzer (0=mute, 100=maximum)

8.6.15.3. Notes

Buzzer does not have “Always high level” operation.

Default values of period and duty-cycle for PWM0 and PWM1 are 63, 50.

Default values of period and duty-cycle for buzzer are 250, 100.

8.6.16. +WPCM Set PCM Configuration

Description	Command	Possible Response(s)
Set PCM configuration	+WPCM=<Clock Rate>,<Sampling Edge>,<Bit Word>,<MSB First>	OK
Get PCM configuration	+WPCM?	+WPCM: <Clock Rate>,<Sampling Edge>,<Bit Word>,<MSB First> OK
Get supported PCM configurations	+WPCM=?	+WPCM: (list of supported<Clock Rate>s), (list of supported<Sampling Edge>s), (list of supported<Bit Word>s), (list of supported<MSB First>s)

8.6.16.1. Description

This command is used to set the PCM configuration.

8.6.16.2. Parameters

<Clock Rate>	Description
0-63	PCM clock divider Default value: 0 <i>Note: PCM clock rate = 1MHz/(PCM clock divider + 1). The PCM clock rate is up to 1MHz.</i>

<Sampling Edge>	Description
0 (default)	Falling edge
1	Rising edge

<Bit Word>	Description
0	8 Bit word
1 (default)	16 Bit word

<MSB First>	Description
0	Disable
1 (default)	Enable

8.6.16.3. Examples

Command	Possible Responses
AT+WPCM=?	+WPCM: (0-63), (0-1), (0-1), (0-1) OK
AT+WPCM?	+WPCM: 0,1,1,1 OK
AT+SPEAKER=3 Note: enable the PCM bus	OK
AT+WPCM=0,1,0,1	OK
AT+WPCM?	+WPCM: 0,1,0,1 OK
AT&F	OK
AT+WPCM?	+WPCM: 0,0,1,1 OK

8.6.16.4. Notes

+WPCM parameter values are automatically saved in non-volatile memory. The default values can be restored using AT&F.

Reset is needed to take into account changes made to <Clock Rate>. On the other hand, changes made to <Sampling Edge>, <Bit Word>, and <MSB First> take effect after the next call.

8.6.17. +WAUDPROF Audio Profile

Description	Command	Possible Response(s)
Set audio profile	+WAUDPROF=<speaker_id>,<profile>	OK
Get audio profile	+WAUDPROF?	+WAUDPROF: <speaker_id>,<current_profile> [+WAUDPROF: <speaker_id>,<current_profile> [.]] OK

Description	Command	Possible Response(s)
Get supported audio profiles	+WAUDPROF=?	+WAUDPROF: (list of supported<speaker_id>s), (list of supported<profile>s) OK

8.6.17.1. Description

This command allows the selection and update of an audio profile with which to establish voice calls.

8.6.17.2. Parameters

<speaker_id>	Description
1	Speaker 1
2	Speaker 2
3	PCM

<profile>	Description
0 (default)	Handset
1	Speaker phone

<current_profile>	Description
0	Handset
1	Speaker phone
2	Custom The profile has been modified by the AT+WMECHO command.

8.6.17.3. Examples

Command	Possible Responses
AT+WAUDPROF=?	+WAUDPROF: (1-3), (0-1) OK
AT+WAUDPROF?	+WAUDPROF: 1,0 +WAUDPROF: 2,0 +WAUDPROF: 3,0 OK

Command	Possible Responses
AT+WMECHO?	+WMECHO: 0,0 +WMECHO: 1,100,"3E80","3E6F","12BB","0320",150,"5A9D","0148" +WMECHO: 2,100,"3E80","3E6F","12BB","0320",150,"5A9D","0148" +WMECHO: 3,100,"3E80","3E6F","12BB","0320",150,"5A9D","0148" OK
AT+WAUDPROF=1,1 Note: change profile of Speaker 1 to Speaker phone	OK
AT+WAUDPROF?	+WAUDPROF: 1,1 +WAUDPROF: 2,0 +WAUDPROF: 3,0 OK
AT+WMECHO?	+WMECHO: 0,0 +WMECHO: 1,256,"3E80","3E6F","12BB","0320",150,"5A9D","0148" +WMECHO: 2,100,"3E80","3E6F","12BB","0320",150,"5A9D","0148" +WMECHO: 3,100,"3E80","3E6F","12BB","0320",150,"5A9D","0148" OK
AT+WMECHO=1,1,3,80,,, "6789"	OK Note: PCM <eCL> and <ecMu2> have been changed to 80 and 0x6789.
AT+WAUDPROF?	+WAUDPROF: 1,1 +WAUDPROF: 2,0 +WAUDPROF: 3,2 OK

Command	Possible Responses
AT+WMECHO?	+WMECHO: 1,1 +WMECHO: 1,256,"3E80","3E6F","12BB","0320",150,"5A9D","0148" +WMECHO: 2,100,"3E80","3E6F","12BB","0320",150,"5A9D","0148" +WMECHO: 3,80,"3E80","3E6F","6789","0320",150,"5A9D","0148" OK

8.6.17.4. Notes

This command is available when the module has finished its initialization.

Updated settings take effect after the next call.

After the audio profile values are changed, +WMECHO parameters are overwritten.

Parameters are automatically saved in non-volatile memory. Default values can be restored using AT&F.

8.6.18. +SIDET Sidetone

Description	Command	Possible Response(s)
Set sidetone (when <type> = 0)	+SIDET=<type>,<analog_gain>	OK +CME ERROR: <err>
Set sidetone (when <type> = 1)	+SIDET=<type>,<digital_gain>	OK +CME ERROR: <err>
Get sidetone value	+SIDET?	+SIDET: <type>,<analog_gain> +SIDET: <type>,<digital_gain> OK
Get supported sidetone values	+SIDET=?	+SIDET: (list of supported <type>s), (list of supported<analog_gain>s) +SIDET: (list of supported<type>s), (list of supported<digital_gain>s) OK

8.6.18.1. Description

This command allows setting the sidetone level.

8.6.18.2. Parameters

<type>	Description
0	Analog audio (Speaker 1 and Speaker 2)
1	Digital audio (PCM)

<analog_gain>	Description
0000-0010	Analog sidetone gain with 2dB steps in Hexadecimal character format: <ul style="list-style-type: none"> • 0x0000 for -26dB • ... • 0x0010 for 6dB Default value: 0007

<digital_gain>	Description
0000-FFFF	Digital sidetone gain in Hexadecimal character format: The range of values would be -1.0 (FFFF) to 0.999969482 (7FFF). For instance, 0x7FFF would represent 0.999969482. Default value: 1CA8

8.6.18.3. Examples

Command	Possible Responses
AT+SIDET=?	+SIDET: 0, (0000-0010) +SIDET: 1, (0000-FFFF) OK
AT+SIDET?	+SIDET: 0, "0007" +SIDET: 1, "1CA8" OK
AT+SIDET=1, "06A8"	OK
AT+SIDET?	+SIDET: 0, "0007" +SIDET: 1, "06A8" OK

8.6.18.4. Notes

For <type>=0, the <analog_gain> takes effect during the call.

For <type>=1, the <digital_gain> takes effect after reset.

Sidetone parameters are automatically saved into non-volatile memory. Default values can be restored using AT&F.

8.6.19. +WMECHO Echo Cancellation and Noise Reduction

Description	Command	Possible Response(s)
Set AEC/NR	<code>+WMECHO=<eState>,<nState>[,<speaker_id>[,<ecL>[,<ecMu0>[,<ecMu1>[,<ecMu2>[,<ecMu3>[,<ecFE_SpeechDelay>[,<esUL_Gmin>[,<esDL_Gmin>]]]]]]]]]</code>	OK
Get AEC/NR status	<code>+WMECHO?</code>	+WMECHO: <eState>,<nState> +WMECHO: <speaker_id>,<ecL>,<ecMu0>,<ecMu1>,<ecMu2>,<ecMu3>,<ecFE_SpeechDelay>,<esUL_Gmin>,<esDL_Gmin> [+WMECHO: <speaker_id>,<ecL>,<ecMu0>,<ecMu1>,<ecMu2>,<ecMu3>,<ecFE_SpeechDelay>,<esUL_Gmin>,<esDL_Gmin> [...]] OK
Get supported AEC/NR values	<code>+WMECHO=?</code>	+WMECHO: (list of supported <eState>s), (list of supported <nState>s), (list of supported <speaker_id>s), (list of supported <ecL>s), (list of supported <ecMu0>s), (list of supported <ecMu1>s), (list of supported <ecMu2>s), (list of supported <ecMu3>s), (list of supported <ecFE_SpeechDelay>s), (list of supported <esUL_Gmin>s), (list of supported <esDL_Gmin>s) OK

8.6.19.1. Description

This command allows enabling or disabling the RX and TX Acoustic Echo Cancellation (AEC), and Noise Reduction (NR). It can also configure the TX Echo Cancellation and Suppression values.

8.6.19.2. Parameters

<eState>	Description
0 (default)	AEC is off
1	AEC is on

<nState>	Description
0 (default)	NR is off
1	NR is on

<speaker_id>	Description
1	Speaker 1
2	Speaker 2
3	PCM

<ecL>	Description
0-382	Filter length in number of coefficients Default value: 100

<ecMu0>	Description
0000-FFFF	Speed for FAP algorithm (Fast convergence speed) in Hexadecimal character format. Default value: 3E80

<ecMu1>	Description
0000-FFFF	Reduction coefficient of FAP speed (medium-high convergence speed) in Hexadecimal character format. The range of values would be -1.0(FFFF) to 0.999969482(7FFF). For instance, 0x7FFF would represent 0.999969482. Default value: 3E6F

<ecMu2>	Description
0000-FFFF	Reduction coefficient of FAP speed (medium-slow convergence speed) in Hexadecimal character format. The range of values would be -1.0(FFFF) to 0.999969482(7FFF). For instance, 0x7FFF would represent 0.999969482. Default value: 12BB

<ecMu3>	Description
0000-FFFF	Reduction coefficient of FAP speed (slow convergence speed) in Hexadecimal character format. The range of values would be -1.0(FFFF) to 0.999969482(7FFF). For instance, 0x7FFF would represent 0.999969482. Default value: 0320

<ecFE_SpeechDelay>	Description
80-200	Number of sample Default value: 150

<esUL_Gmin>	Description
0000-FFFF	UL attenuation of echo suppression in Hexadecimal character format. The range of values would be -1.0(FFFF) to 0.999969482(7FFF). For instance, 0x7FFF would represent 0.999969482. Default value: 5A9D

<esDL_Gmin>	Description
0000-FFFF	DL attenuation of echo suppression in Hexadecimal character format. The range of values would be -1.0(FFFF) to 0.999969482(7FFF). For instance, 0x7FFF would represent 0.999969482. Default value: 0148

8.6.19.3. Examples

Command	Possible Responses
AT+WMECHO=?	+WMECHO: (0-1), (0-1), (1-3), (0-382), (0000-FFFF), (0000-FFFF), (0000-FFFF), (0000-FFFF), (80-200), (0000-FFFF), (0000-FFFF) OK
AT+WMECHO?	+WMECHO: 0, 0 +WMECHO: 1, 100, "3E80", "3E6F", "12BB", "0320", 150, "5A9D", "0148" +WMECHO: 2, 100, "3E80", "3E6F", "12BB", "0320", 150, "5A9D", "0148" +WMECHO: 3, 100, "3E80", "3E6F", "12BB", "0320", 150, "5A9D", "0148" OK
AT+WMECHO=1, 1	OK Note: AEC and NR are on.
AT+WMECHO?	+WMECHO: 1, 1 +WMECHO: 1, 100, "3E80", "3E6F", "12BB", "0320", 150, "5A9D", "0148" +WMECHO: 2, 100, "3E80", "3E6F", "12BB", "0320", 150, "5A9D", "0148" +WMECHO: 3, 100, "3E80", "3E6F", "12BB", "0320", 150, "5A9D", "0148" OK

Command	Possible Responses
AT+WMECHO=1,1,3,80,,, "6789"	OK Note: PCM <eCL> and <ecMu2> have been changed to 100 and 0x6789.
AT+WMECHO?	+WMECHO: 1,1 +WMECHO: 1,100,"3E80","3E6F","12BB","0320",150,"5A9D","0148" +WMECHO: 2,100,"3E80","3E6F","12BB","0320",150,"5A9D","0148" +WMECHO: 3,80,"3E80","3E6F","6789","0320",150,"5A9D","0148" OK

8.6.19.4. Notes

Updated AEC/NR settings take effect after the next call.

All parameter values are automatically saved into non-volatile memory.

After the AEC/NR values are changed, +WAUDPROF parameters are overwritten.

8.6.20. +WSVN IMEI Software Version Number

Description	Command	Possible Response(s)
Action command	AT+WSVN=<IMEI SVN>	OK
Read command	AT+WSVN?	+WSVN: < IMEI SVN > OK
Test command	AT+WSVN=?	+WSVN: (List of supported < IMEI SVN >s) OK

8.6.20.1. Description

This command is used to assign, read, and update the IMEI Software Version Number (IMEI SVN).

8.6.20.2. Parameters

<IMEI SVN>	Description
Integer type	0-98

8.6.20.3. Examples

Command	Possible Responses
AT+W SVN=?	+W SVN: (0-98) OK
AT+W SVN? Note: Request IMEI SVN	+W SVN: 10 OK
AT+W SVN=11 Note: Update the IMEI SVN	OK

8.6.20.4. Notes

Once the action command is executed and returns OK, the new value will be stored in non-volatile memory.

This command is available when the module has finished its initialization.

8.6.21. +WMSN Serial Number

Description	Command	Possible Response(s)
Read serial number	+WMSN	Serial Number: <SN> OK
Test if command is supported	+WMSN=?	OK

8.6.21.1. Description

This command allows for reading the module's serial number.

8.6.21.2. Parameters

<SN>	Description
Alphanumeric type	Serial number (15 characters)

8.6.22. +WIMEI IMEI Number

Description	Command	Possible Response(s)
Write IMEI number into non-volatile memory	+WIMEI="<IMEI>"	OK +CME ERROR: <err>
Read IMEI number	+WIMEI?	+WIMEI: <IMEI> OK
Test if command is supported	+WIMEI=?	OK +CME ERROR: <err>

8.6.22.1. Description

This command allows the one-time writing of the IMEI number into non-volatile memory.

8.6.22.2. Parameters

<IMEI>	Description
Integer type	15-digit IMEI as defined in GSM 23.003[21] Default value: 012345678901237

8.6.22.3. Notes

Although the <IMEI> parameter is 15-digits long, only 14-digits will be accepted as input as the last digit is a checksum. This checksum is automatically computed and updated in non-volatile memory on the next module reboot.

The IMEI write command can only be performed when the current IMEI is the default.

8.6.23. +WEXTCLK External Clocks Setting

Description	Command	Possible Response(s)
Write external clock setting	AT+WEXTCLK=<output>, <status>	OK
Read external clock setting	AT+WEXTCLK?	+WEXTCLK: <output>, <status> +WEXTCLK: <output>, <status> OK
Test if command is supported	AT+WEXTCLK=?	+WEXTCLK: (list of supported <output>s), (list of supported <status>es) OK

8.6.23.1. Description

This command allows generating 32 kHz and 26 MHz on the output clock pins of the embedded module.

8.6.23.2. Parameters

<output>	Description
1	32kHz output (32K_CLKOUT)
2	26MHz output (26M_CLKOUT)

<status>	Description
0	Disabled (default)
1	Enabled

8.6.23.3. Examples

Command	Possible Responses
AT+WEXTCLK=?	+WEXTCLK: (1,2), (0,1) OK
AT+WEXTCLK?	+WEXTCLK: 1,0 +WEXTCLK: 2,0 OK
AT+WEXTCLK=1	ERROR
AT+WEXTCLK=1,1	OK << MEASURE THE 32 KHZ SIGNAL >>
AT+WEXTCLK=2,1	OK << MEASURE THE 26 MHZ SIGNAL >>
AT+WEXTCLK?	+WEXTCLK: 1,1 +WEXTCLK: 2,1 OK
AT+WEXTCLK=1,0	OK
AT+WEXTCLK?	+WEXTCLK: 1,0 +WEXTCLK: 2,1 OK
AT+WEXTCLK=2,0	OK

Command	Possible Responses
AT+WEXTCLK?	+WEXTCLK: 1,0 +WEXTCLK: 2,0 OK

8.6.23.4. Notes

The parameters are not saved in non-volatile memory.

This command is available when the module has finished its initialization.

8.6.24. +WMADC ADC Voltage Setting

Description	Command	Possible Response(s)
Write ADC voltage setting	AT+WMADC=<Adc>,<range>	OK +CME ERROR: <err>
Read current ADC voltage setting	AT+WMADC?	+WMADC: 0,<range>,1,<range> OK
Test if command is supported	AT+WMADC=?	+WMADC: (0,1),(0,1) OK

8.6.24.1. Description

This command allows for setting the range of ADC voltage to either 1V or 3V. The change will take effect only after the module is rebooted.

8.6.24.2. Parameters

<Adc>	Description
0	Auxiliary ADC (AUX_ADC0)
1	Auxiliary ADC (AUX_ADC1)

<range>	Description
0 (default)	1V
1	3V

8.6.24.3. Example

Command	Possible Responses
AT+WMADC=?	+WMADC: (0,1), (0,1) OK
AT+WMADC=1	ERROR
AT+WMADC=1,1	OK
AT+WMADC?	+WMADC: 0,0,1,1 OK

8.6.24.4. Notes

This command is available when the module has finished its initialization.

8.6.25. +WLDO Enable/Disable 2V8_LDO Pin

Description	Command	Possible Response(s)
Enable or disable the 2V8_LDO pin	AT+WLDO=<mode>	OK
Read the 2V8_LDO status	AT+WLDO?	+WLDO: <mode> OK
Test if command is supported	AT+WLDO=?	+WLDO: (list of supported <mode>s) OK

8.6.25.1. Description

This command enables or disables the 2V8_LDO pin of the embedded module.

8.6.25.2. Parameters

<mode>	Description
0 (default)	Disable
1	Enable in full power mode
2	Enable in low power mode

8.6.25.3. Examples

Command	Possible Responses
AT+WLDO=?	+WLDO: (0-2) OK
AT+WLDO?	+WLDO: 0 OK Note: the 2V8_LDO pin is disabled
AT+WLDO=1 Note: Enable the 2V8_LDO pin in high power mode	OK
AT+WLDO?	+WLDO: 1 OK
AT+WLDO=2 Note: Enable the 2V8_LDO pin in low power mode	OK

8.6.25.4. Notes

This command is available when the module has finished its initialization.

The <mode> parameter value is automatically saved in non-volatile memory.

8.6.26. +WAEN Set Custom Emergency Numbers

Description	Command	Possible Response(s)
Set custom emergency number(s)	AT+WAEN=<mode>, [<AEN1>], [<AEN2>], [<AEN3>], [<AEN4>], [<AEN5>], [<AEN6>], [<AEN7>], [<AEN8>], [<AEN9>], [<AEN10>]	OK
Read custom emergency number(s)	AT+WAEN?	+WAEN: [<AEN1>], [<AEN2>], [<AEN3>], [<AEN4>], [<AEN5>], [<AEN6>], [<AEN7>], [<AEN8>], [<AEN9>], [<AEN10>] OK

Command	Possible Responses
AT+WAEN?	+WAEN: ", "", "", "", "", "", "", "", "", "" OK
AT+WAEN=1, "1234"	OK
AT+WAEN?	+WAEN: "1234", "", "", "", "", "", "", "", "", "" OK
AT+WAEN=1,, "1234"	OK (Add number)
AT+WAEN?	+WAEN: "1234", "1234", "", "", "", "", "", "", "", "" OK
AT+WAEN=0,, "1234"	OK (Delete number)
AT+WAEN?	+WAEN: "1234", "", "", "", "", "", "", "", "", "" OK
AT+WAEN=1, "111"	OK (Modify existing number)
AT+WAEN?	+WAEN: "111", "", "", "", "", "", "", "", "", "" OK
AT+WAEN=2	"112", "911", "000", "08", "110", "118", "119", "999" OK Note: When no SIM card is inserted.
AT+WAEN=0	OK (Delete all)
AT+WAEN?	+WAEN: "", "", "", "", "", "", "", "", "", "" OK
AT+WAEN=1, "1", "2", "3", "4", "5", "6", "7", "8", "9", "10", "11"	ERROR (More than 10 AENs entered)
AT+WAEN=1, "1234567"	ERROR (AEN is more than 6 digit s)
AT+WAEN=1, "xxx" AT+WAEN=1, "1xx" AT+WAEN=1, "xx1"	ERROR (Non digit AEN)
AT+WAEN=3, "333" AT+WAEN="abc"	ERROR (Invalid <mode>)

8.6.26.4. Notes

This command is available when the module has finished its initialization.

AENx are automatically saved in non-volatile memory; there is no effect when using AT&F.

Bear the following in mind when using this command:

- If <mode> is 0, and there is no other parameter in the AT command, all emergency numbers in the flash memory are erased.
- If <mode> is 0, and there are other <AENx> parameters in the AT command, the appropriate emergency number in the array is erased (same as the AENx).
- If <mode> is 1, up to 10 additional emergency numbers can be added or modified; where each emergency number is composed of 6 digits and are stored into non-volatile memory.
- If <mode> is 2, the “conventional” emergency numbers in the firmware and SIM are available for reading or listing. The AT command can send all these numbers back to the terminal.
- The command is able to read or list additional emergency numbers and send these numbers back to the terminal.
- When making emergency number calls, e.g., **ATD**, additional emergency numbers have higher priority checking than the “conventional” ones programmed in the firmware or SIM.

8.6.27. +WDDM Downlink DTMF Detection

Description	Command	Possible Response(s)
Start/Stop DTMF detection	AT+WDDM=<mode>	OK
Read the DTMF detection status	AT+WDDM?	+WDDM: <mode> OK
Test if command is supported	AT+WDDM=?	+WDDM: (list of supported <mode>s) OK
Unsolicited response		+WDDI: <char>,<duration>

8.6.27.1. Description

This Sierra Wireless proprietary command allows the start/stop of the downlink DTMF detection.

8.6.27.2. Parameters

<mode>	Description
0 (default value)	Stop DTMF detection
1	Start DTMF detection

<char>	Description
possible detected DTMF characters: [0-9],[A-D],*, #	Detected DTMF character

<duration>	Description
90-1200000	Duration of the incoming character in milliseconds Range: 90 (depending on DTMF decoder behavior) to 1200000 approximately (value limited by the network capabilities)

8.6.27.3. Examples

Command	Possible Responses
AT+WDDM=?	+WDDM: (0-1) OK
AT+WDDM?	+WDDM: 0 OK Note: Detection stopped
AT+WDDM=1 Note: Start the DTMF detection	OK
AT+WDDM?	+WDDM: 1 OK Note: Detection started
Make a call	+WDDI: "*", 90 Note: "*" char was detected within 90ms from downlink
AT+WDDM=0 Note: stop the DTMF detection	OK

8.6.27.4. Notes

This command is available when the module has finished its initialization.

The <mode> parameter is stored in non-volatile memory using AT&W command. The default value can be restored using AT&F.

8.6.28. +WPOW Transmitted Power Measurement

Description	Command	Possible Response(s)
Start/Stop repeated burst signal from the MS	AT+WPOW=<Mode>,<Arfcn>[,<Pcl>]	OK
Read command	AT+WPOW?	OK
Test if command is supported	AT+WPOW=?	OK

8.6.28.1. Description

This Sierra Wireless proprietary command allows generating a repeated burst signal from the MS with a constant power level on a given channel. The tester can measure the transmitted signal level.

8.6.28.2. Parameters

<mode>	Description
1	Transmitted power measurement START
2	Transmitted power measurement STOP

<Arfcn>	Description
Absolute RF channel number Note: If <Mode> is 2, <Arfcn> is ignored.	
975-1023, 0-124	GSM 900/ EGSM 900
512-885	DCS 1800

<Pcl>	Description
Power control level Note: If <Mode> is 2, <Pcl> is ignored.	
5-19	GSM 900/ EGSM900 (If <Pcl> is not specified, 5 is applied)
0-15	DCS 1800 (If <Pcl> is not specified, 0 is applied)

8.6.28.3. Examples

Command	Possible Responses
AT+CFUN=4	OK
AT+WPOW=?	OK
AT+WPOW?	OK

Command	Possible Responses
AT+WPOW=2,0 Note: stop the signal transmission	OK
AT+WPOW=1,1000	OK
AT+WPOW=2,0	OK
AT+WPOW=1,512,10	OK
AT+WPOW=2,0	OK
AT+WPOW=1,200	ERROR (Incorrect <Arfcn>)
AT+WPOW=1	ERROR
AT+WPOW=1,1,3	ERROR (<Arfcn> and <Pcl> is not matched)

8.6.28.4. Notes

This command is available when the module has finished its initialization.

Read command has no effect (returns OK).

+WPOW command is intended for non-signaling measurement purposes; protocol stack must be disabled, ie, AT+CFUN=4 must be sent before +WPOW command.

After a “start” +WPOW command is set, another “start” should not be sent until a “stop” +WPOW command is set.

If <Mode> is 2, <Arfcn> and <Pcl> are ignored.

8.7. Call and Network Proprietary Commands

8.7.1. *PSCSCN Call State Change Notification

Description	Command	Possible Response(s)
Select notification presentation mode	*PSCSCN=<mode>	OK +CME ERROR: <err>
Get the current mode	*PSCSCN?	*PSCSCN: <mode> OK

8.7.1.1. Description

This command allows presentation of information about CS call states as well as audio or in-call notifications related to current call.

This command does not replace +CLCC command. TE is notified whenever the state of a call changes, this avoid TE to use polling mechanism with +CLCC command to know the states of each call.

When <mode>=0, set command disables the presentation of call state change URC (*PSCSC).

When <mode>=1, set command enables the presentation of call state change URC (*PSCSC) every time the state of a call changes.

Description	Result Code
Call state change	*PSCSC: <Call Id>,<State>,<Status>,[<Number>],[<type>],[<Line Id>],[<CauseSelect>],[<Cause>],[<Bearer>]

The optional fields of the URC are filled only when information is available (i.e depending of the state of the call), otherwise they are left empty.

8.7.1.2. Parameters

<mode>	Description
0	Disable presentation of all notifications
1	Enable presentation of *PSCSC

<Call Id>	Description
0	Call Id not yet assigned (alerting MT call)
1..7	Call Id representing a CS speech call
>8	Call Id representing a CS data call

<State>	Description
0	MO call SETUP (no control by SIM)
1	MO call SETUP WITH CONTROL BY SIM (accepted)
2	MO call SETUP ERROR (control by SIM rejected or other problem)
3	MO call PROCEED
4	MO call ALERT (at distant)
5	MO call CONNECT (with distant)
6..9	RFU
10	MT call SETUP
11	MT call SETUP ACCEPTED (Bearer capabilities accepted by the ME)
12	MT call SETUP REJECTED (Bearer capabilities rejected by the ME)
13	MT call ALERT
14	MT call CONNECT (ME has successfully accepted the call)
15	MT call CONNECT ERROR (ME was not able to accept the call)
16..19	RFU

<State>	Description
20	Call DISCONNECT BY NETWORK
21	Call DISCONNECT BY USER
22	Call REJECT BY USER
23..29	RFU
30	MO call SETUP – Call initiated by SAT (SET UP CALL command received)
31	MO call PROCEED – Call initiated by SAT (SET UP CALL command received)
32	MO call ALERT (at distant) – Call initiated by SAT (SET UP CALL command received)
33	MO call CONNECT (with distant) – Call initiated by SAT (SET UP CALL command received)

<Status>	Description
0	Call in ACTIVE state
1	Call in HOLD state (applicable only for speech calls, either MO or MT)
2	Call in MULTIPARTY ACTIVE state (applicable only for speech calls, either MO or MT)
3	Call in MULTIPARTY HOLD state (applicable only for speech calls, either MO or MT)

<Number>	Description
String type	Phone number (same as in +CLIP)

<type>	Description
Integer type	Type of address (same as in +CLIP)

<Line Id>	Description
1	Line 1
2	Line 2 (auxiliary line)

<Cause Select>	Description
Integer type	Cause selection

<Cause>	Description
Integer type	Cause

<Bearer>	Description
String type	Hexadecimal representation format of bearer capability (for data calls only).

8.7.1.3. Notes

When an unsolicited response with <Cause>=84 is received, for example:

```
*PSCSC: 0, 2,,,,, 16, 84,
```

this means that the phone number specified is FDN restricted.

This command uses information available at APPI interface (application i/f). AT parser does not interface directly with protocol stack so it does not have immediate access to L3 messages, this means that <state> does not match L3 messages exactly as they are defined in 24.008 recommendation.

8.7.1.4. SIM Toolkit- SET UP CALL

Values 30..33 for <state> are used when a SET UP CALL proactive command has been received from the SAT. This call is initiated internally in the ME by STK. *PSCSCS notification will be broadcasted as URC: the MO call has been initiated by STK, no AT channel is associated to the call.

Examples:

MO speech alerting at distant and initiated on line 1

```
*PSCSCS: 1, 4, 1,,, 1, , ,
```

MO speech call connected to "11111111" and active on line 1

```
*PSCSCS: 1, 5, 1, "11111111", 129, 1, , ,
```

MT data call connected to "123456" and active on line 1, BC list = A28881211563A6

```
*PSCSCS: 8, 14, 1, "123456", 129, 1, , , "A28881211563A6"
```

8.7.2. +CNAP Calling Name Presentation

Description	Command	Possible Response(s)
Control +CNAP URC	+CNAP=<n>	OK +CME ERROR: <err>
Get status of CNAP	+CNAP?	+CLIR: <n>,<m> OK +CME ERROR: <err>
Get supported values	+CNAP=?	+CNAP: (list of supported <n>s) OK +CME ERROR: <err>

8.7.2.1. Parameters

<n>	Description
0	+CNAP notification is disabled
1	Enabled unsolicited result code: +CNAP: <name>,<validity>

<m>	Description
0	Network does not provide the CNAP service
1	Network provides the CNAP service
2	Unknown (e.g. no network, etc.)

<validity>	Description
0	Name presentation allowed
1	Presentation restricted
2	Name unavailable
3	Name presentation restricted

8.7.2.2. Notes

CNAP (Calling Name Presentation) is a supplementary service provided by the network. The +CNAP command enables or disables the presentation of the name provided by the network.

8.7.3. *PSFSNT Field Strength Notification

Description	Command	Possible Response(s)
Select notification mode	*PSFSNT=<mode>	OK +CME ERROR: <err>
Get the current mode	*PSFSNT?	PSFSNT: <mode> OK

8.7.3.1. Description

This command allows presentation of field strength notification.

Set command enable (or disable) the presentation of *PSFS each time field strength increase or decrease of 5 dBm.

Description	Result Code
Field strength notification	*PSFS: <field strength>

8.7.3.2. Parameters

<mode>	Description
0	Disable presentation of notification
1	Enable presentation of notification

<field strength>	Description
0	GSM RX level is less than -110 dBm
1..62	GSM RX level is less than -109..-48 dBm
63	GSM RX level is greater than -48 dBm
255	GSM RX level is unavailable

8.7.3.3. Notes

The values defined are not the same as for +CSQ command.

8.7.4. *PSCSSC Call Successful Control

Description	Command	Possible Response(s)
Set mode	*PSCSSC=<mode>	OK +CME ERROR: <err>
Get current mode	*PSCSSC?	*PSCSSC: <mode> OK

8.7.4.1. Description

This command controls the emission of the result code for MO speech successful set-up.

If “Connected line identification presentation” supplementary service is activated (refer to section 3.5.3 +COLP Connected Line Identification), result code for ATD command will be sent to TE when call is connected to the called party (successful call set-up).

If “Connected line identification presentation” supplementary service is not activated (refer to section 3.5.3 +COLP Connected Line Identification), result code for ATD can be sent as soon as call set-up is started or after call is connected to the called party (after successful call set-up).

Set command allows selection of <mode> for MO speech call result code.

If user sets <mode>=1 when +COLP is also activated, ERROR will be returned. Mode will remain 0.

8.7.4.2. Parameters

<mode>	Description
0	OK is returned only when call is connected to the remote party
1 (default)	OK is returned when call setup is started. The user is not informed of call successful connection to remote party. If the call fails, NO ANSWER or NO CARRIER will be sent after OK.

8.7.5. *PSCCDN Call Connection and Disconnection Notification

Description	Command	Possible Response(s)
Set mode	*PSCCDN=<mode>	OK +CME ERROR: <err>
Get current mode	*PSCCDN?	*PSCCDN: <mode> OK
Get supported values	*PSCCDN=?	*PSCCDN: (list of supported <mode>s) OK

8.7.5.1. Description

This command allows presentation of information about connection or disconnection of a CS call (either MT or MO). This URC allow TE to exactly know which call is being connected or disconnected (NO CARRIER URC is not sufficient to discriminate calls id).

Set command enables or disables the presentation of notification result code from ME to TE.

When <mode>=1, *PSCALL result code is sent to TE on connection or disconnection of call <call id>

Description	Result Code
Call notification	*PSCALL: <call Id>,<status>[,<number>]

8.7.5.2. Parameters

<mode>	Description
0	Disable notification
1	Enable notification

<call id>	Description
0	Waiting call (alerting, no call id assigned yet)
1..7	Speech call ID
> 8	Data call id

<status>	Description
0	Disconnected
1	Connected

<number>	Description
String type	Phone number (when <status>=1)

8.7.5.3. Notes

Special case: to inform that current waiting call has been disconnected: *PSCALL: 0,0 is sent.

The +CLCC command can be used to get more information about a specific call.

8.7.6. *PSENGI Network Information

Description	Command	Possible Response(s)
Select an information to retrieve	*PSENGI=<mode>	If <mode>=0 *PSSCI: (see <mode> parameter for details) If <mode>=1 *PSNCI: (see <mode> parameter for details) If <mode>=2 *PSGDMI: (see <mode> parameter for details) If <mode>=3 *PSQI: (see <mode> parameter for details) If <mode>=4 *PSGPRS: (see <mode> parameter for details) If <mode>=5 *PSSCI: (see <mode> parameter for details) *PSNCI: (see <mode> parameter for details) OK +CME ERROR: <err>
Get supported values	*PSENGI=?	*PSENGI : (list of supported <mode>), (list of supported possible responses) OK +CME ERROR: <err>

8.7.6.1. Description

This command allows the network information to be displayed.

8.7.6.2. Parameters

<mode>	Description
0	Serving cell information *PSSCI: <ARFCN>,<C1>,<C2>,<C32>,<C31>,<RxLevel>,<Ptmsild>,<PLMN>,<MCC>, <MNC>,<LAC>,<CellId>,<RAC>,<T3212Value>,<PagingOccurence>, <LevelServiceSupported>,<NetworkModeOperation>,<TA>,<BSIC>

<mode>	Description
1	Neighbor cells information (one line per neighbor cell) *PSNCI: <ARFCN>,<C1>,<C2>,<C32>,<C31>,<PLMN>,<MCC>,<MNC>,<LAC>,<CellId>,<RxLevel>,<BSIC>
2	GSM dedicated mode information *PSGDMI: <RxLevelFull>,<TxLevel>,<FrequencyHoppingInd>,<CipheringInd><RxQualityFull>
3	Quality information *PSQI: <HOFailOnTotalHO>
4	GPRS information *PSGPRS: <ARFCN>,<G>,<PBCCH>,<PAT>,<MCC>,<MNC>,<NOM>,<TA>,<RAC>
5	Serving cell and Neighbor cells information (one line per neighbor cell) *PSSCI: <ARFCN>,<C1>,<C2>,<C32>,<C31>,<RxLevel>,<Ptmsild>,<PLMN>,<MCC>,<MNC>,<LAC>,<CellId>,<RAC>,<T3212Value>,<PagingOccurrence>,<LevelServiceSupported>,<NetworkModeOperation>,<TA>,<BSIC> *PSNCI: <ARFCN>,<C1>,<C2>,<C32>,<C31>,<PLMN>,<MCC>,<MNC>,<LAC>,<CellId>,<RxLevel>,<BSIC>

<ARFCN>	Description
Integer type	Absolute Radio Frequency Channel Number

<C1>	Description
Integer type	GSM cell selection criteria

<C2>	Description
Integer type	GSM cell reselection criteria

<C31>	Description
Integer type	GPRS cell selection criteria

<C32>	Description
Integer type	GPRS cell reselection criteria

<RxLevel>	Description
Integer type	Received signal level

<Ptmsild>	Description
Integer type	Packet Temporary Mobile Subscriber Identity

<PLMN>	Description
Integer type	Public Land Mobile Network (composed of MCC and MNC)
<MCC>	Description
Integer type	Mobile Country Code
<MNC>	Description
Integer type	Mobile Network Code
<LAC>	Description
Integer type	Location Area Code (in decimal value)
<CellId>	Description
Integer type	Cell Identity (in decimal value)
<BSIC>	Description
Integer type	Base Station Identity Code
<RAC>	Description
Integer type	Routing Area Code When <mode>=0, in decimal value When <mode>=4, in hexadecimal value
<T3212Value>	Description
Integer type	Timer 3212 value (used for periodic location update)
<PagingOccurrence>	Description
Integer type	BsPaMfrms parameter used to compute paging period
<LevelServiceSupported>	Description
Integer type	1 if GPRS is supported on serving cell, 0 otherwise

<NetworkMode Operation> <NOM>	Description
Integer type	GPRS Network Operation Mode For <mode>=0, Network Operation Mode 1,2,3 as <NetworkModeOperation>=0,1,2 For <mode>=4, Network Operation Mode 1,2,3 as <NOM>=1,2,3
<TxLevel>	Description
Integer type	Transmit power level
<FrequencyHopingInd>	Description
Integer type	1 if frequency hopping is used, 0 otherwise
<CipheringInd>	Description
Integer type	1 if ciphering is used, 0 otherwise
<RxQualityFull>	Description
Integer type	Received signal quality (computed in non DTX mode)
<HOFailOnTotalHO>	Description
Integer type	Handover ratio in dedicated mode (failed handover number / total handovers)
<G>	Description
Integer type	GPRS available (1) or not available ("-") in serving cell
<PBCCH>	Description
Integer type	If PBCCH is present, PBCCH ARFCN is displayed else "-" or if Frequency Hopping is used "H"
<PAT>	Description
Integer type	Priority Access Threshold (GSM Rec, 04.08 / 10.5.2.37b). Supported values 0-4
<TA>	Description
Integer type	Timing Advance value

8.7.6.3. Notes

If the parameter is not available, it will be shown as “-” or 255.

8.7.7. +WGPRS GPRS Multislot Class

Description	Command	Possible Response(s)
Action	AT+WGPRS=<mode>,,,<class>	OK
Read	AT+WGPRS?	+WGPRS: <mode>,<class> OK
Test	AT+WGPRS=?	+WGPRS: (list of supported <mode>s), (), (), (list of supported <class>s) OK
Unsolicited response		<None>

8.7.7.1. Description

This Sierra Wireless proprietary command modifies the GPRS multislot class parameter.

8.7.7.2. Parameters

<mode>	Description
4	Definition of the GPRS multislot class. This parameter represents the GPRS class chosen by the user to perform power saving (by reducing TX /uplink time slots). Only <class> is used

<class>	Description
This is the GPRS or EGPRS multislot class number.	
2	Multislot class 2
8	Multislot class 8
10	Multislot class 10 (default)

8.7.7.3. Examples

Command	Possible responses
AT+WGPRS=?	+WGPRS: (4), (), (), (2,8,10) OK
AT+WGPRS=4, , , 8	OK
AT+WGPRS?	+WGPRS: 4,8 OK

8.7.7.4. Notes

GPRS multislot class parameters are automatically saved into non-volatile memory.

GPRS multislot class setting takes effect after reset.

User can skip or input anything for parameter2 and parameter3; the firmware will not take the two parameters into account.

>> 9. TCP/IP Commands

9.1. Introduction

This chapter presents detailed information about the AT command set associated with the Sierra Wireless IP feature.

9.1.1. Informational Indicators

The commands in this chapter use the following graphics as informational indicators to identify aspects of the commands' usage, and are presented at the beginning of each command.



This picture indicates the +WIND indication from which the AT command is allowed. X values can be: 1, 3, 4, 16.



This picture indicates that a SIM card must be inserted to support the AT command.



This picture indicates that an AT command is supported even if the SIM card is absent.



This picture indicates that the PIN 1/CHV 1 code must be entered to support the AT command.



This picture indicates that an AT command is supported even if the PIN 1/CHV 1 code is not entered.



This picture indicates that the PIN 2/CHV 2 code must be entered to support the AT command.



This picture indicates that an AT command is supported even if the PIN 2/CHV 2 code is not entered.

9.2. Principles

The AT+WIP AT Commands implements the TCP/IP protocols using custom AT commands. The commands are sent from an external application and the corresponding responses are sent back from the WS6318 to the external application.

AT+WIP commands involve:

- A host computer, which issues the AT+WIP commands
- The AirPrime WS6318 module
- The rest of the Internet/Intranet

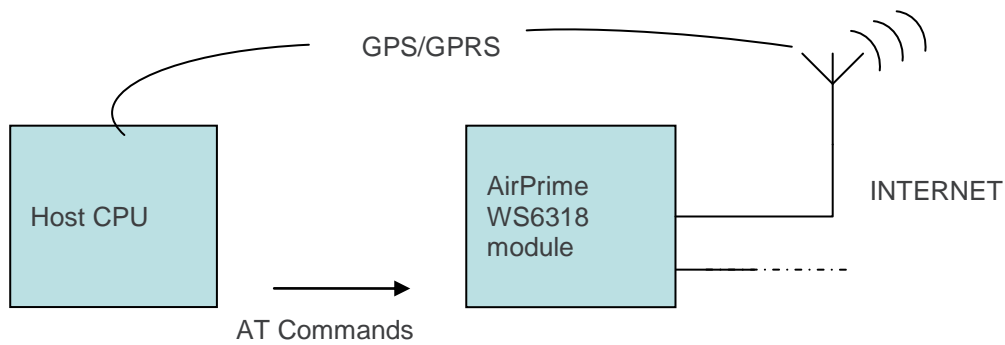

Multiplexing: Several sockets can be operating at once. The +WIPDATA command allows the temporary identification of the UART in data mode with a given socket. The data written on the UART is transferred through the socket. The data which arrives on the socket can be read from the UART.

In AT mode, the host receives an unsolicited event when the data arrives on the socket.

9.2.1. Sockets Identification

Sockets are identified by a pair of numbers: the first one identifies the protocol; the second one identifies a given socket of the protocol.

9.2.1.1. Possible Protocols

The possible protocols are:

- 1 = UDP
- 2 = TCP in connect mode (Client)
- 3 = TCP in listen mode (Server)

Two pairs with different protocol numbers but the same index identifies two distinct sockets.

Example: Both 1,7 and 2,7 are valid identifiers simultaneously; the former identifies a UDP socket and the later, a TCP connected socket.

9.2.1.2. Number of Sockets

The number of sockets per protocol is limited and is listed as follows.

- UDP : 8 sockets
- TCP Clients : 8 sockets
- TCP Servers : 4 sockets

9.3. General Configuration

9.3.1. IP Stack Handling +WIPCFG



9.3.1.1. Description

The +WIPCFG command is used for performing the following operations:

- start TCP/IP stack
- stop TCP/IP stack
- configuring TCP/IP stack

9.3.1.2. Syntax

if <mode> = 0,1

Action Command

AT+WIPCFG=<mode>

OK

if <mode>=2

Action Command

AT+WIPCFG=<mode>,<opt num>,<value>

OK

if <mode>=4

Action Command

AT+WIPCFG=<mode>,<action>

OK

Read Command

AT+WIPCFG?

+WIPCFG: <optnum>,<value>

[+WIPCFG: <optnum>,<value>[...]]

OK

Test Command

AT+WIPCFG=?

OK

9.3.1.3. Parameters and Defined Values

<mode>:	requested operation
0	stop TCP/IP stack
1	start TCP/IP stack
2	configure TCP/IP stack
4	TCP/IP stack configuration management

<opt num>:	configuration option identifier
0	<p>WIP_NET_OPT_IP_TTL – Default TTL of outgoing data grams</p> <p>This option is a limit on the period of time or number of iterations or transmissions that a unit of data can experience before it should be discarded. The time to live (TTL) is an 8-bit field in the Internet Protocol (IP) header. It is the 9th octet of 20. The default value of this parameter is 64. Its value can be considered as an upper bound on the time that an IP datagram can exist in an internet system. The TTL field is set by the sender of the datagram, and reduced by every host on route to its destination. If the TTL field reaches zero before the datagram arrives at its destination, then the datagram is discarded. This is used to avoid a situation in which an undelivered datagram keeps circulating in the network.</p> <p>range: 0-255 (default value: 64)</p>
1	<p>WIP_NET_OPT_IP_TOS – Default TOS of outgoing parameters</p> <p>The IP protocol provides a facility for the Internet layer to know about the various tradeoffs that should be made for a particular packet. This is required because paths through the Internet vary widely in terms of the quality of service provided. This facility is defined as the "Type of Service" facility, abbreviated as the "TOS facility".</p> <p>The TOS facility is one of the features of the Type of Service octet in the IP datagram header. The Type of Service octet consists of the following three fields:</p> <pre> 0 1 2 3 4 5 6 7 +---+---+---+---+---+---+---+ PRECEDENCE TOS MBZ +---+---+---+---+---+---+ </pre> <p>The first field is "PRECEDENCE". It is intended to denote the importance or priority of the datagram.</p> <p>The second field is "TOS" which denotes how the network should maintain the tradeoffs between throughput, delay, reliability, and cost.</p> <p>The last field is "MBZ" (Must Be Zero), is currently unused and is set to 0. The TOS field can have the following values:</p> <pre> 1000 -- minimize delay 0100 -- maximize throughput 0010 -- maximize reliability 0001 -- minimize monetary cost 0000 -- normal service </pre> <p>For more information on this field please refer to RFC1349.</p> <p>range: 0-255 (default value: 0)</p>
2	<p>WIP_NET_OPT_IP_FRAG_TIMEO - Time to live in seconds of incomplete fragments</p> <p>When a datagram's size is larger than the MTU (Maximum Transmission Unit) of the network, then the datagram is divided into smaller fragments. These divided fragments are sent separately. This option specifies the Time to live for these fragments.</p> <p>range: 1-65535 (default value: 60)</p>

<opt num>:	configuration option identifier
3	<p>WIP_NET_OPT_TCP_MAXINITWIN – Number of segments of initial TCP window This option is used to specify the number of segments in the initial TCP window. A TCP window specifies the amount of outstanding (unacknowledged by the recipient) data a sender can send on a particular connection before it gets an acknowledgment back from the receiver. The primary reason for the window is congestion control. range: 0-65535 (default value: 0)</p>
4	<p>WIP_NET_OPT_TCP_MIN_MSS - Default MSS of off-link connections This parameter specifies the maximum size of TCP segments which would be sent. By default, the value of this parameter is set to 536. Hence, the firmware would not send any TCP segment having a length greater than 536 bytes without a header. range: 536-1460 (default value: 536)</p>
5	<p>WIP_NET_OPT_DEBUG_PORT This option is used to specify the port on which the debug traces are to be sent. range: 0-3 (default value: 0)</p>
12	<p>AT_WIP_NET_OPT_PREF_TIMEOUT_VALUE - Used for TCP sockets to configure the packet segmentation on the IP network side. This option is used to specify the maximum time to wait between two successive data chunks received from the UART/serial port (please see +WIPDATA AT command). It allows the application to buffer a certain amount of data before writing on IP network side. Each unit in the range represents 1 second. For example, a value of 10 for this option will give a wait time of 10 seconds. Default value for this option is 0. This value means that no specific process is done to avoid TCP packets segmentation: data are written onto the IP network without any delay after the reception of data. In this case, some TCP packets sent on the IP network may be smaller than TCP_MIN_MSS value. As mentioned above, setting a value of 10 for this option will make the application wait at least 10 seconds or twice the TCP_MIN_MSS value to be reached before sending data on the IP network. In this case, TCP packets size sent on the IP network should be equal to at least TCP_MIN_MSS (Default value = 536 bytes). range: 0-100 (default value: 0)</p>
13	<p>AT_WIP_NET_OPT_ESC_SEQ_NOT_SENT : Used to configure whether a “+++” escape sequence should be sent as data to the peer. By default, this option is set to 0 which means that the “+++”sequence is sent to the peer as data. If set to 1, “+++”sequence is not sent as data to the peer. range: 0-1 (default value:0)</p>
14	<p>AT_WIP_NET_OPT_AUTO_SWITCH - 0: Does not automatically switch to AT mode 1: Switches automatically to AT mode range: 0-1 (default value:0)</p>

<action>:	requested operation on TCP/IP stack parameter management
0	Stored configuration is erased (restore factory settings)
1	Stores the current configuration parameters

<value>:	Definition
Integer type	Range of values for different configuration options

Note: UART(WIP_NET_OPT SOCK_MAX + 1) sockets are reserved when UDP sockets are created (and not for TCP sockets); one socket buffer is added to support/afford DNS accesses.

9.3.1.4. Parameter Storage

Only one IP stack configuration set can be saved into non-volatile memory.

- “AT+WIPCFG=4,1” is used to store the TCP/IP stack configuration parameters into the non-volatile memory
- “AT+WIPCFG=4,0” is used to free the TCP/IP stack configuration storage

Executing “AT+WIPCFG=1” will apply default parameter values wherever applicable, but it is still possible to change option values at run time using “AT+WIPCFG=2,<optnum>,<optvalue>”.

9.3.1.5. Possible Errors

The possible error message is displayed only if “AT+CMEE=1” is activated. Otherwise, only “ERROR” is displayed.

“+CMEE” AT Error Code	Description
800	invalid option
801	invalid option value
802	not enough memory
820	error writing configuration in non-volatile memory
821	error freeing configuration in non-volatile memory
844	stack already started
850	unknown reason

9.3.1.6. Examples

Command	Responses
AT+WIPCFG=1 Note: Start IP Stack	OK
AT+WIPCFG?	+WIPCFG: 0,64 +WIPCFG: 1,0 +WIPCFG: 2,60 +WIPCFG: 3,0 +WIPCFG: 4,536 +WIPCFG: 5,0 +WIPCFG: 12,10 +WIPCFG: 13,0 +WIPCFG: 14,0 OK
AT+WIPCFG=2,0,10 Note: Configure TTL of IP Stack	OK

Command	Responses
AT+WIPCFG?	+WIPCFG: 0,10 +WIPCFG: 1,0 +WIPCFG: 2,60 +WIPCFG: 3,0 +WIPCFG: 4,536 +WIPCFG: 5,0 +WIPCFG: 12,10 +WIPCFG: 13,0 +WIPCFG: 14,0 OK
AT+WIPCFG=0 Note: Stop the TCP/IP Stack	OK
AT+WIPCFG=4,1 Note: Store IP configuration parameters into non-volatile memory	OK
AT+WIPCFG=4,0 Note: Free IP configuration parameters stored in non-volatile memory	OK

9.3.1.7. Notes

It is recommended to change the default settings of the WIP stack using +WIPCFG only when it is required. Changing the parameter values especially the max number of sockets and the max TCP buffer size with high values leads to over consumption of the stack memory which causes the firmware to crash. Hence, care must be taken when the default settings of the stack is changed using the +WIPCFG command.

The following option values set by the +WIPCFG command are taken into consideration at run time. The option values below (except for AT_WIP_NET_OPT_PREF_TIMEOUT_VALUE and AT_WIP_NET_OPT_ESC_SEQ_NOT_SENT) will be taken into consideration at the next start up only if these are saved in non-volatile memory before stopping the stack.

- WIP_NET_OPT_IP_TTL
- WIP_NET_OPT_IP_TOS
- WIP_NET_OPT_IP_FRAG_TIMEO
- WIP_NET_OPT_TCP_MAXINITWIN
- WIP_NET_OPT_TCP_MIN_MSS
- WIP_NET_OPT_DEBUG_PORT
- AT_WIP_NET_OPT_PREF_TIMEOUT_VALUE
- AT_WIP_NET_OPT_ESC_SEQ_NOT_SENT
- AT_WIP_NET_OPT_AUTO_SWITCH

9.3.2. Bearers Handling +WIPBR



9.3.2.1. Description

The +WIPBR command can be used to:

- select the bearer
- start/close the bearer
- configure different bearer options such as access point name

9.3.2.2. Syntax

if <cmdtype> = 0,1 or 5

Action Command

```
AT+WIPBR=<cmdtype>,<bid>
```

OK

if <cmdtype> = 2

Action Command

```
AT+WIPBR=<cmdtype>,<bid>,<opt num>,<value>
```

OK

if <cmdtype> = 3

Action Command

```
AT+WIPBR=<cmdtype>,<bid>,<opt num>
```

```
+WIPBR: <bid>,<opt num>,<value>
```

OK

if <cmdtype> = 4

Action Command

```
AT+WIPBR=<cmdtype>,<bid>,<mode>[,<login>,<password>,[<caller identity>]]
```

OK

if <cmdtype> = 6

Action Command

```
AT+WIPBR=<cmdtype>,<bid>,<mode>
```

OK

<p><i>Read Command</i></p> <p>AT+WIPBR?</p> <p><bid>,<state></p> <p>[<bid>,<state>[...]]</p> <p>OK</p>
<p><i>Test Command</i></p> <p>AT+WIPBR=?</p> <p>OK</p>

9.3.2.3. Parameters and Defined Values

<cmdtype>:	type of command
0	close bearer
1	open bearer
2	set value of different bearer options
3	get value of different bearer options
4	start bearer
5	stop bearer
6	bearer configuration management

<bid>:	bearer identity
5	GSM
6	GPRS

<opt num>:	bearer option identifier
0	WIP_BOPT_LOGIN – username (string) max: 32 characters
1	WIP_BOPT_PASSWORD – password (string) max: 32 characters
2	WIP_BOPT_DIAL_PHONENB – phone number (string) max: 32 characters
7	WIP_BOPT_PPP_PAP - Allow PAP authentication range: 0-1
8	WIP_BOPT_PPP_CHAP - Allow CHAP authentication range: 0-1
9	WIP_BOPT_PPP_MSCHAP1 - Allow MSCHAPv1 authentication range: 0-1
10	WIP_BOPT_PPP_MSCHAP2 - Allow MSCHAPv2 authentication range: 0-1
11	WIP_BOPT_GPRS_APN - Address of GGSN (string) max: 96 characters

<opt num>:	bearer option identifier
13	WIP_BOPT_GPRS_HEADERCOMP - Enable PDP header compression range: 0-1
14	WIP_BOPT_GPRS_DATACOMP - Enable PDP data compression range: 0-1
15	WIP_BOPT_IP_ADDR - Local IP address (IP/string)
16	WIP_BOPT_IP_DST_ADDR - Destination IP address (IP/string)
17	WIP_BOPT_IP_DNS1 - Address of primary DNS server (IP/string)
18	WIP_BOPT_IP_DNS2 - Address of secondary DNS server (IP/string)
19	WIP_BOPT_IP_SETDNS - Configure DNS resolver when connection is established range: 0-1
20	WIP_BOPT_IP_SETGW - Set interface as default gateway when connection is established range: 0-1

<value>:	Definition
Integer type	Range of values for different bearer options

<mode>:	Description
0	client

<caller identity>	Description
ASCII string (type ASCII*)	If not specified, then target will accept all DATA calls (independent of caller identification). If specified, then target will only accept calls from <caller identity> (which is the GSM data call number of the GSM client).

* IP addresses are displayed in alpha numeric dot format. e.g. 192.168.0.1. When no IP address is known, "0.0.0.0" is displayed.

Caution: *The options WIP_BOPT_IP_ADDR, WIP_BOPT_IP_DST_ADDR, WIP_BOPT_IP_DNS1 and WIP_BOPT_IP_DNS2 can be read after the bearer connection is established successfully. If an attempt is made to read the options value before the bearer connection is established successfully, an incorrect IP address will be received.*

9.3.2.4. Parameter Storage

Several bearer configuration sets can be saved.

Calling AT+WIPBR=6,<bid>,1 twice with the same <bid> will store the last configuration set.

- "AT+WIPBR=6,<bid>,1" is used to store the bearer configuration parameters set associated with the bearer <bid> into non-volatile memory.
- "AT+WIPBR=6,<bid>,0" is used to free the bearer configuration parameters set associated with the bearer <bid>.

Executing "AT+WIPBR=1,<bid>" will open bearer <bid> with default parameters of the bearer when existing.

9.3.2.5. Possible Errors

The possible error message is displayed only if “AT+CMEE=1” is activated. Otherwise, only “ERROR” is displayed.

“+CMEE” AT Error Code	Description
800	invalid option
801	invalid option value
802	not enough memory left
803	operation not allowed in the current WIP stack state
804	device already open
807	bearer connection failure : line busy
808	bearer connection failure : no answer
814	bearer connection failure : PPP authentication failed
815	bearer connection failure : PPP IPCP negotiation failed
820	error writing configuration in non-volatile memory
821	error freeing configuration in non-volatile memory
847	bearer connection failure: WIP_BOPT_GPRS_TIMEOUT time limit expired before GPRS bearer connected
848	impossible to connect to the bearer
849	connection to the bearer has succeeded but a problem has occurred during the data flow establishment

9.3.2.6. Examples

Command	Responses
AT+WIPBR?	1,0 6,1 OK Note: Bearer UART1 is open but not started bearer GPRS is open and started
AT+WIPBR?	OK Note: No bearer has been opened yet
AT+WIPBR=1,6 Note: Open GPRS bearer	OK
AT+WIPBR=2,6,11,“APN name” Note: Set APN of GPRS bearer	OK
AT+WIPBR=3,6,11 Note: Get APN of GPRS bearer	+WIPBR: 6,11,“APN name” OK
AT+WIPBR=4,6,0 Note: Start GPRS bearer	OK

Command	Responses
AT+WIPBR=5,6 Note: Stop GPRS bearer	OK
AT+WIPBR=0,6 Note: Close GPRS bearer	OK
AT+WIPBR=1,5 Note: Open GSM bearer	OK
AT+WIPBR=2,5,2,"phonenumber" Note: Set the phonenumber for GSM bearer	OK
AT+WIPBR=2,5,15,"1.1.1.1" Note: Set the local IP address for GSM bearer	OK
AT+WIPBR=2,5,16,"2.2.2.2" Note: Set the destination IP address for GSM bearer	OK
AT+WIPBR=3,5,15 Note: Read the local IP address for GSM bearer	+WIPBR: 5,15,"0.0.0.0" OK Note: Local IP address is not set as GSM bearer is still not connected
AT+WIPBR=3,5,16 Note: Read the destination IP address for GSM bearer	+WIPBR: 5,16,"0.0.0.0" OK Note: Destination IP address is not set as GSM bearer is still not connected
AT+WIPBR=4,5,0 Note: Start the GSM bearer as a client	OK
AT+WIPBR=3,5,15 Note: Read the local IP for GSM bearer	+WIPBR: 5,15,"1.1.1.1" OK
AT+WIPBR=3,5,16 Note: Read the destination IP for GSM bearer	+WIPBR: 5,16,"2.2.2.2" OK
AT+WIPBR=5,5 Note: Stop the GSM bearer	OK
AT+WIPBR=0,5 Note: Close the GSM bearer	OK

9.3.2.7. Notes

9.3.2.7.1. For Starting a Bearer

The mandatory parameters to start a bearer in client mode are <cmdtype>, <bid> and <mode>.

Depending on the mode and the bearer type, additional parameters are required or forbidden:

Bid	Mode	Other Parameters
5	0	None
6	0	None

9.3.2.7.2. For Opening a Bearer

Opening a bearer only consists of associating the IP protocol stack with the specified bearer. The corresponding bearer setup has to be done through the already existing AT commands.

Several bearers can be opened at the same time but only one bearer can be started at a time.

If both DNS1 and DNS2 are displayed as "0.0.0.0" in the unsolicited message when bearer is opened in server mode, it means that connecting to a remote IP host through a URL will fail.

The options WIP_BOPT_DIAL_REDIALCOUNT and WIP_BOPT_DIAL_REDIALDELAY will not be implemented through AT commands. Nevertheless, for future compatibility reasons, opt num 3 and 4 are kept as reserved.

For GSM bearer, the options WIP_BOPT_IP_ADDR and WIP_BOPT_IP_DST_ADDR will display valid addresses only when the bearer is started and connected, else it will display an address "0.0.0.0".

9.4. IP Protocol Services

9.4.1. Service Creation +WIPCREATE



9.4.1.1. Description

The +WIPCREATE command is used to create UDP, TCP client, TCP server sockets, and FTP sessions associated with the specified index.

If a local port is specified while creating a socket, the created socket will be assigned to this port; if not, a port will be assigned dynamically by the firmware application. If peer IP and peer port is specified, the created socket will be connected to the specified IP and port.

The TCP server cannot be used to transfer data. To transfer data, it creates a local TCP client socket. This process of creating a local socket is referred to as "spawning". When a server socket is created using spawning, the socket passively listens on a specified port for incoming connections. The diagram below shows the different states managed for a TCP server.

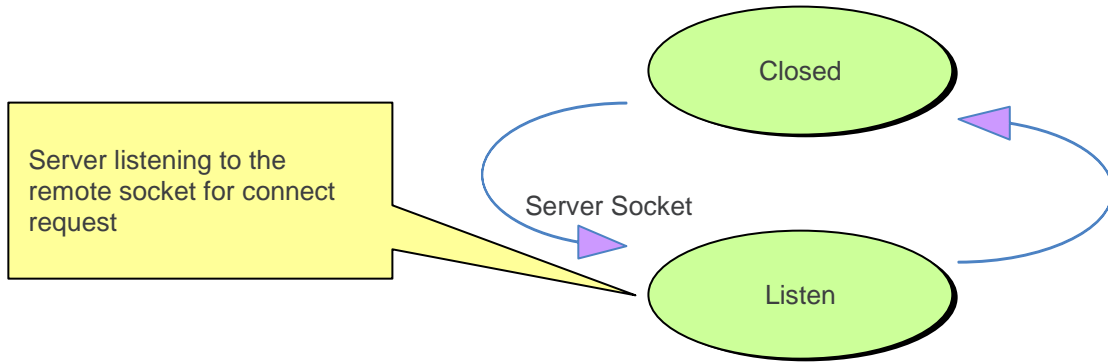

On reception of a connection request from a remote client socket, a server socket does the following:

- spawns a new socket (client) to connect to the remote socket
- transfers data between the spawned socket and the remote socket
- remains in listening mode and is ready to accept requests from other clients

The diagram below shows the connection establishment procedure.

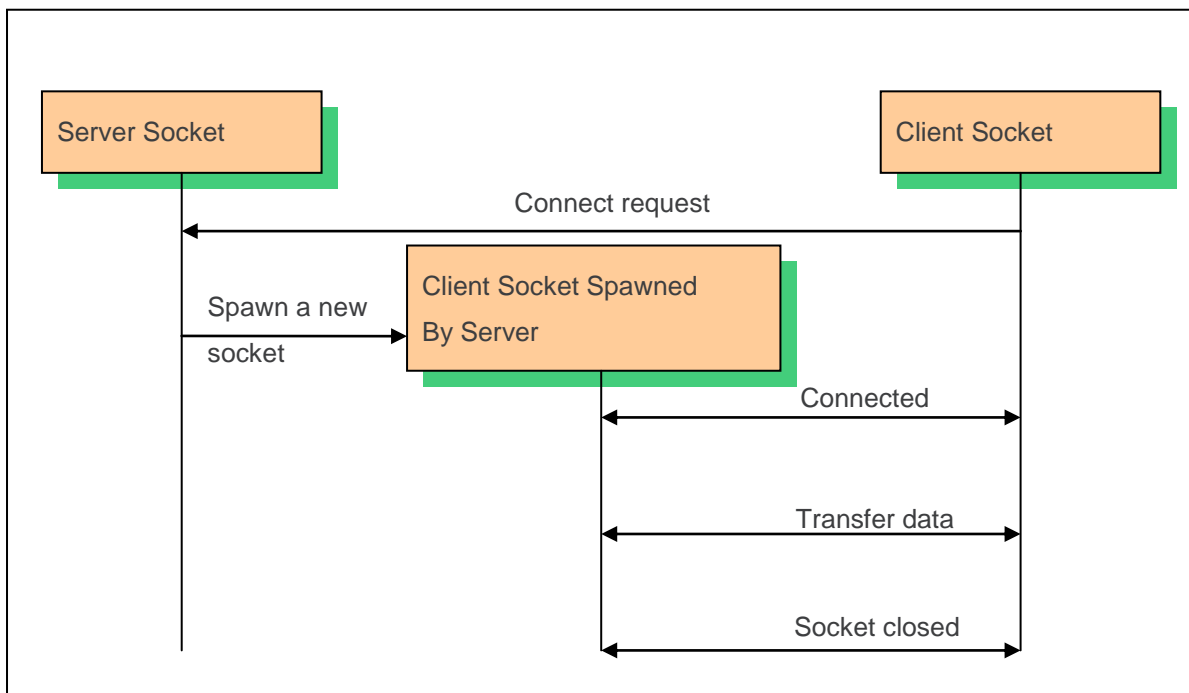

9.4.1.2. Syntax

if <mode> = 1

```

Action Command
AT+WIPCREATE=<mode>,<communication index>,[<local port>] [,<peer IP>,<peer port>]
OK
    
```

if <mode>=2

```

Action Command
AT+WIPCREATE=<mode>,<communication index>,<peer IP>,<peer port>
OK
    
```

if <mode>=3

```

Action Command
AT+WIPCREATE=<mode>,<server index>,<local port>,<from idx>,<to idx>
OK
    
```

if <mode>=4

```

Action Command
AT+WIPCREATE=<mode>,<index>,<server>[,<peer_port>],<username>,<password>
[,<account>]
OK
    
```

if <mode>=1 or 2

```

Unsolicited response
+WIPREADY: <mode>,<communication index>
    
```

if <mode>=3

```

Unsolicited response
+WIPACCEPT: <server index>,<communication idx>
    
```

9.4.1.3. Parameters and Defined Values

<mode>:	Specifies type of socket
1	UDP
2	TCP client
3	TCP server
4	FTP

<index>:	Definition
Session identifier	TCP/UDP/FTP session identifier

<local port>:	Definition
	Local TCP/UDP port

<peer IP>:	Definition
numeric form (e.g. "85.12.133.10") or as a DNS entry (e.g. "www.sierrawireless.com")	Peer IP address; a string between quotes indicating an address either in
<peer port>:	Definition
Range: 1-65535	Peer port or the server port For TCP/UDP, this parameter is the port of the peer socket. For FTP, this parameter is the server port (default value for FTP: 21).
<from idx>:	Definition
Range: 1-8	Minimum index for spawned TCP sockets
<server index>:	Definition
Range: 1-4	TCP server socket identifier
<to idx>:	Definition
Range: 1-8	Maximum index for spawned TCP sockets
<communication index>:	Definition
Range: 1-8	Indexes reserved for spawned sockets. These cannot be used by other sockets even if the spawned sockets are not created yet.
<server>:	Definition
Server address or proxy address	Server address or proxy address for FTP. This parameter can either be a 32-bit number in dotted decimal notation ("xxx.xxx.xxx.xxx") or an alphanumeric string format for hostname.
<user name>:	Definition
username	Username for authentication in string format.
<password>:	Definition
password	Password for authentication in string format.

<account>:	Definition
account information	Account information of the user in string format. This is required by some FTP servers during authentication phases.

9.4.1.4. Parameter Storage

None

9.4.1.5. Possible Errors

The possible error message is displayed only if “AT+CMEE=1” is activated. Otherwise, only “ERROR” is displayed.

“+CMEE” AT Error Code	Description
800	invalid option
803	operation not allowed in the current TCP/IP stack state
830	bad index
832	bad port number
834	not implemented
836	memory allocation error
837	bad protocol
839	error during channel creation
840	UDP/TCP socket session or FTP session is already active
842	destination host unreachable (whether host unreachable, Network unreachable, response timeout)
845	attempt is made to reserve/create a client socket which is already reserved/opened by TCP server/client
851	incorrect number of parameters submitted
860	protocol undefined or internal error

9.4.1.6. Examples

Command	Responses
AT+WIPCREATE=1,1,80 Note: Create the UDP socket on local port 80 with communication index = 1 ⇔ WS6318 acts as a UDP server awaiting for incoming datagram on local port 80	OK Note: An unsolicited event +WIPREADY: 1,1 will be received once the UDP socket is ready for use
AT+WIPCREATE=1,1,"www.sierrawireless.com",80 Note: Create the UDP socket on an arbitrary free local port with peer IP and peer port 80 with communication index = 1 ⇔ WS6318 acts as a UDP client that can send datagram towards the remote entity	OK Note: An unsolicited event +WIPREADY: 1,1 will be received once the UDP socket is ready for use

Command	Responses
AT+WIPCREATE=1,1,80,"www.sierrawireless.com",80 Note: Create the UDP socket on local port 80 with peer IP and peer port 80 with communication index = 1 ⇔ WS6318 acts as a UDP client and a UDP server : it can send datagram towards the remote entity and receive datagram on the specified local port	OK Note: An unsolicited event +WIPREADY: 1,1 will be received once the UDP socket is ready for use
AT+WIPCREATE=3,1,80,5,8 Note: Create the TCP server on port 80 with server index = 1 ⇔ WS6318 acts as a TCP server : from now on, it will spawn TCP client sockets from communication index 5 to 8	OK Note: An unsolicited event +WIPACCEPT: 1,5 will be received once the TCP server is ready for use
AT+WIPCREATE=2,1,"IP ADDR",80 Note: Create the TCP client on port 80 with index=1 ⇔ WS6318 acts as a TCP client : from now on, it can communicate with the remote specified entity through communication index 1	OK Note: An unsolicited event +WIPREADY: 2,1 will be received once the TCP client is ready for use
AT+WIPCREATE=4,1,"ftp.sierrawireless.com","admin","123456" Note: Create an FTP session ⇔ towards the remote specified FTP server. Communication index to be used then is 1.	OK

9.4.1.7. Notes

The maximum number of sockets can be set to 20 so that the TCP/IP stack can handle 8 UDP sockets, 8 TCP client sockets and 4 TCP servers all at the same time. If an FTP session is used, 2 TCP sockets (passive mode) or 2-3 TCP sockets (active mode) will be consumed for FTP control and data channels (2 sockets for TCP server in active mode during the PORT handshake; although the TCP server socket will be released immediately after the handshake).

Starting a TCP server requires specifying the maximum number of communication sockets that can be spawned. This can be done using the <from idx> and <to idx> parameters. Note that the value set for <to idx> should be equal or more than <from idx>.

The maximum communication socket that can be created using the firmware is 8. Hence, the range for <communication index> and <from idx>, <to idx> is 1-8. Note that the spawned communication socket and the TCP client socket share the same communication index.

It is not possible to create a client socket with AT+WIPCREATE=2, x, y, z when x is already reserved by a server with AT+WIPCREATE=3, <server idx>, <local port>, a, b where $a \leq x \leq b$. Similarly, it is not possible to reserve a range with AT+WIPCREATE=3, <server idx>, <local port>, a, b if one of the TCP client socket indexes between a and b is already reserved, be it by a client or a server range.

The <from idx> and <to idx> are reserved for the server socket till the server socket and the spawned sockets are closed explicitly. So when trying to create a new TCP server socket, the <from idx> and <to idx> should be different from what was used earlier. A parameter used as <from_idx> can't be used as <to_idx> anymore for other TCP server socket creation until spawned sockets with specified <from_idx> and <to_idx> are explicitly closed along with the TCP server socket and vice versa.

When no more communication index is available in the TCP server's range (or no more resources to accept new incoming connections), any peer trying to connect to the server will receive an accept () immediately followed by a shutdown () ("peer close").

It is possible to have a TCP client and TCP server sockets running at the same time in the same embedded module. In this scenario, when the connection is established between the TCP server and

TCP client sockets, it is necessary to unmap the mapped socket on one index in order to send/receive data on a socket which is created on another index. It is possible to use CMUX logical ports and can have an interface connection (like UART connection) for each socket. For example, TCP client socket on one logical port and TCP server socket on another. In this case, it is not necessary to map or unmap the UART connections to send or receive the data from the socket.

The +WIPCREATE command causes the connection and authentication to the FTP server. If several file uploads and retrievals are required to/from the same server, a single connection with +WIPCREATE is needed. Then, each file operation will be done (one +WIPFILE command per operation), and the FTP connection will be released with +WIPCLOSE.

SIM card is required only if FTP session is established through GSM or GPRS. An FTP session on a UART will work without a SIM card.

9.4.2. Closing a Service +WIPCLOSE



9.4.2.1. Description

The +WIPCLOSE command is used to close a socket or an FTP session.

9.4.2.2. Syntax

<p><i>Action command</i></p> <p>AT+WIPCLOSE=<protocol>,<idx></p> <p>OK</p>
<p><i>Read Command</i></p> <p>AT+WIPCLOSE?</p> <p>NONE</p>
<p><i>Test Command</i></p> <p>AT+WIPCLOSE=?</p> <p>OK</p>
<p><i>Unsolicited response</i></p> <p>+WIPPEERCLOSE: <protocol>,<idx></p>

9.4.2.3. Parameters and Defined Values

<protocol>:	protocol type
1	UDP
2	TCP client
3	TCP server

<protocol>:	protocol type
4	FTP

<idx>:	Definition
Socket identifier	This parameter is the index of the socket or FTP session created with the +WIPCREATE command.

9.4.2.4. Parameter Storage

None

9.4.2.5. Possible Errors

The possible error message is displayed only if “AT+CMEE=1” is activated. Otherwise, only “ERROR” is displayed.

“+CMEE” AT Error Code	Description
802	not enough memory
803	operation not allowed in the current TCP/IP stack state
830	bad index
831	bad state
834	not implemented
837	bad protocol

9.4.2.6. Examples

Command	Responses
AT+WIPCLOSE=1,1 Note: Close UDP socket with communication index 1	OK
AT+WIPCLOSE=2,1 Note: Close TCP client with communication index 1	OK
AT+WIPCLOSE=3,1 Note: Close TCP server with communication index 1	OK
AT+WIPCLOSE=4,1 Note: Close FTP session with communication index 1	OK +WIPPEERCLOSE: 4,1 Note: An unsolicited event +WIPPEERCLOSE: 4,1 is received once the FTP session is closed.

9.4.2.7. Notes

After issuing the +WIPCLOSE command, no more data can be sent or received over the socket/session. In case of FTP protocol, the closure of the FTP session is indicated by the +WIPPEERCLOSE unsolicited response when the +WIPCLOSE command is used to close the session.

In case of TCP/UDP sockets, the response "OK" is returned when the +WIPCLOSE command is executed irrespective of whether the socket is active or not. But in the case of an FTP session, the "OK" response is returned if the +WIPCLOSE command is executed when the session is active. Else, "+CME ERROR: 831" error code is returned.

9.4.3. Service Option Handling +WIPOPT



9.4.3.1. Description

The +WIPOPT command is used to read and/or to configure different parameters on sockets or FTP sessions.

9.4.3.2. Syntax

if <action> = 1

<p><i>Action Command</i></p> <p>AT+WIPOPT=<protocol>,<idx>,<action>,<optnum></p> <p>OK</p>

if <action>=2

<p><i>Action Command</i></p> <p>AT+WIPOPT=<protocol>,<idx>,<action>,<optnum>,<optval></p> <p>OK</p>
--

<p><i>Read Command</i></p> <p>AT+WIPOPT?</p> <p>NONE</p>

<p><i>Test Command</i></p> <p>AT+WIPOPT=?</p> <p>OK</p>
--

if <action> = 1

<p><i>Unsolicited response</i></p> <p>+WIPOPT: <protocol>,<optnum>,<optval></p>

9.4.3.3. Parameters and Defined Values

<protocol>:	protocol type
1	UDP
2	TCP client
3	TCP server
4	FTP

<idx>:	Definition
	Socket or FTP identifier

<action>:	Requested operation
1	read the value of an option
2	write the value of an option

<optnum>:	Definition
Integer type	Option that can be read or written

<optval>:	Definition
Integer type	Value of an option

9.4.3.4. Parameter Storage

None

9.4.3.5. Possible Errors

The possible error message is displayed only if “AT+CMEE=1” is activated. Otherwise, only “ERROR” is displayed.

“+CMEE” AT Error Code	Description
800	invalid option
801	invalid option value
803	operation not allowed in the current TCP/IP stack state
830	bad index
834	not implemented
835	option not supported
837	bad protocol
850	unknown reason
860	protocol undefined or internal error
863	protocol delete error

“+CMEE” AT Error Code	Description
864	protocol list error

9.4.3.6. Examples

Command	Responses
AT+WIPOPT=2,1,2,8,20 Note: Set TTL for TCP client.	OK
AT+WIPOPT=2,1,1,8 Note: Get TTL for TCP client.	+WIPOPT: 2,8,20 OK
AT+WIPOPT=3,1,2,9,10 Note: Set TOS for TCP server	OK
AT+WIPOPT=3,1,1,9 Note: Get TOS for TCP server	+WIPOPT: 3,9,10 OK
AT+WIPOPT=1,1,1,1 Note: Get peer port for UDP	+WIPOPT: 1,1,80 OK
AT+WIPOPT=4,1,2,40,1 Note: Set data representation type for FTP	OK
AT+WIPOPT=4,1,1,40 Note: Get data representation type for FTP	+WIPOPT: 4,1,1 OK

9.4.3.7. Notes

It is possible to change and retrieve the option value using +WIPOPT command only when the socket (given by <idx>) is active, else it returns error.

Refer to the following table for the options that can be applied to UDP, TCP client and TCP server sockets.

opt num	Value Format	Option Type	Description	UDP	TCP Client	TCP Server
0	0-65535	WIP_COPT_PORT	Port of the socket	R	R	R
1	0-65535	WIP_COPT_PEER_PORT	Port of the peer socket	R	R	-
2	string	WIP_COPT_PEER_STRADDR	Address of the peer socket	R	R	-
6	0-65535	WIP_COPT_NREAD	Number of bytes that can currently be read on the socket default: 0	R	R	-

opt num	Value Format	Option Type	Description	UDP	TCP Client	TCP Server
7	0-1	WIP_COPT_NODELAY	When set to TRUE, TCP packets are sent immediately, even if the buffer is not full enough. When set to FALSE, the packets will be sent either, a) by combining several small packets into a bigger packet b) when the data is ready to send and the stack is idle. default: 0	-	RW	RW
8	1-255	WIP_COPT_TTL	Time-to-leave for packets default: 64	RW	RW	RW
9	0-255	WIP_COPT_TOS	Type of service default: 0	RW	RW	RW

Refer to the following table for the options that can be applied to an FTP session.

opt num	Value Format	Option Type	Description
40	0-1	Boolean	Data representation type <ul style="list-style-type: none"> 0: ASCII (default value) 1: Binary
41	0-1	Boolean	FTP mode <ul style="list-style-type: none"> 0: Active 1: Passive (default value)

9.5. Data Exchange for Protocol Services

This section deals with the data exchange for the services over TCP/IP. All the commands required for the data exchange through different services are mentioned in succeeding sections.

9.5.1. File Exchange +WIPFILE



9.5.1.1. Description

The +WIPFILE command defines the “file system” services that send a block of data through standard TCP/IP protocols. This command is used for file transfer/reception.

The data can be transferred using two modes: continuous mode and continuous transparent mode.

9.5.1.1.1. [ETX] Escaping Mechanism

In case an [ETX] character needs to be transmitted as data, it should be preceded by a [DLE] character. A single [ETX] character marks the end of transmission. Similarly, [ETX] characters received from the internet are sent to the host through the serial port preceded by a [DLE] character.

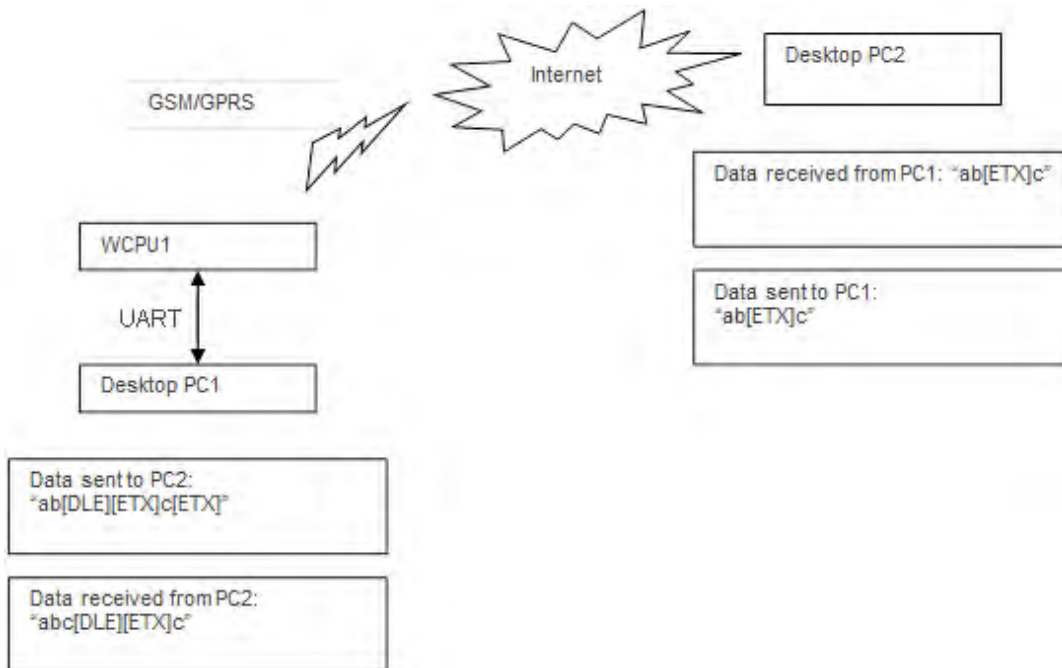

The schematic above explains how [ETX] characters, which have a special meaning in the firmware, are handled on the WS6318 embedded module.

On the transmitting side, when [ETX] characters are escaped by a DLE (use case: Desktop PC1 sends data to the embedded module. Data contains an [ETX] character escaped by a [DLE] character: [DLE][ETX] sequence); then the [ETX] character is transmitted as data.

On the receiving side, when an [ETX] character is received as data (use case: PC2 sends data to the embedded module. Data contains an [ETX] character), then the [ETX] character will be preceded by a [DLE] character when it is sent to the host through the serial port.

9.5.1.1.2. [DLE] Escaping Mechanism

In case a [DLE] character needs to be transmitted as data, it should be preceded by another [DLE] character. A single [DLE] character, not preceded by another [DLE] character will not be transmitted. Similarly, [DLE] characters received are sent to the host through the serial port preceded by another [DLE] character.

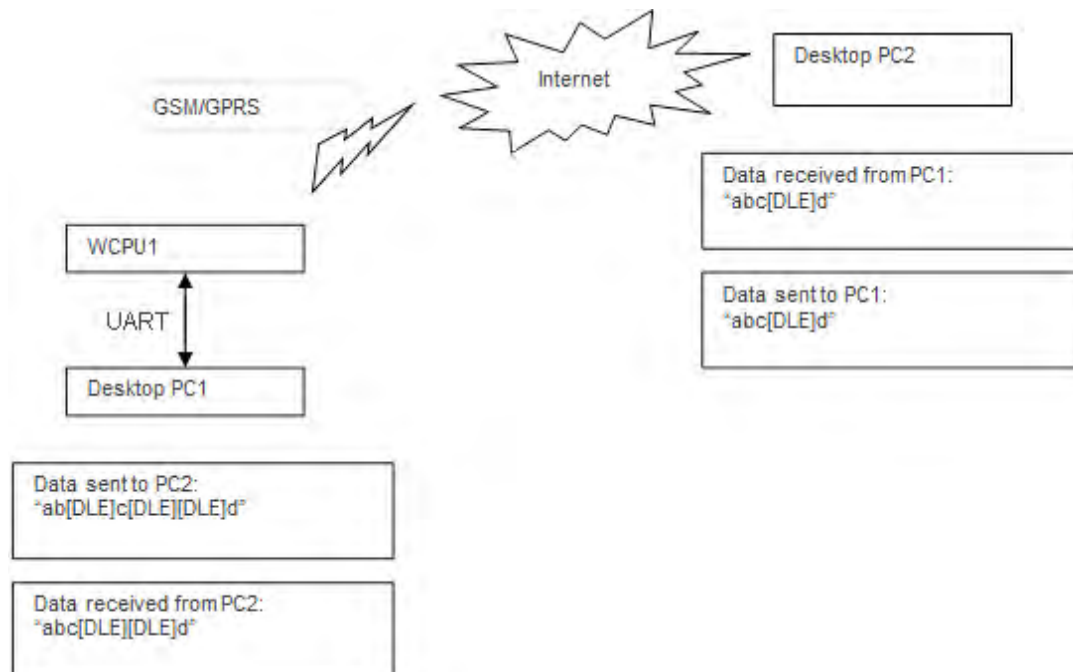

The schematic above explains how [DLE] characters, which have a special meaning in the firmware, are handled on the WS6318 embedded module.

On the transmitting side, when [DLE] characters are escaped by another [DLE] character (use case: Desktop PC1 sends data to the embedded module. Data contains a non escaped [DLE] character, and another escaped [DLE] character: [DLE][DLE] sequence), then the [DLE] character is transmitted as data. A single [DLE] character is ignored and not transmitted.

On the receiving side, when a [DLE] character is received as data (use case: PC2 sends data to the embedded module. Data contains a [DLE] character), then the [DLE] character will be preceded by another [DLE] character when it is sent to the host through the serial port.

9.5.1.2. Session in Continuous Mode

In continuous mode, an [ETX] character is considered as an end of data. In case an [ETX]/[DLE] character needs to be transmitted as data, it should be preceded by a [DLE] character. Similarly, [ETX]/[DLE] characters received by the TCP/IP stack from the internet are sent to the host through the serial port preceded by a [DLE] character.

The UART can be switched back to AT mode either by:

1. sending an [ETX] character
2. sending +++ sequence with 1 second guard time before and after the sequence
3. controlling the DTR signal using AT&D command

When the UART leaves data mode, currently unsent data are transferred.

9.5.1.3. FTP Session in Continuous Transparent Mode

In this mode, [DLE]/[ETX] characters are considered as normal data and not as special characters. In case a [ETX]/[DLE] character is received, it will not be preceded by a [DLE] character before sending it to the UART.

The UART can be switched back to AT mode either by,

1. sending +++ sequence with 1 second guard time before and after the sequence
2. controlling the DTR signal using AT&D command

When the UART leaves data mode, currently unsent data are transferred.

9.5.1.4. Syntax

<p><i>Action Command</i></p> <p>AT+WIPFILE=<protocol>,<index>,<mode>,<filename>[,<dle_mode>]</p> <p>CONNECT</p> <p>...</p> <p>OK</p>
<p><i>Read Command</i></p> <p>AT+WIPFILE?</p> <p>OK</p>
<p><i>Test Command</i></p> <p>AT+WIPFILE=?</p> <p>OK</p>

9.5.1.5. Parameters and Defined Values

<protocol>:	Protocol Type
4	FTP

<idx>:	Definition
	Channel identifier

<mode>:	File Transfer Mode
1	Switches the UART to data mode and prints the content of the file on the UART. The end of the file is marked by an [ETX] character and the UART switches back to AT mode. This mode is used for downloading files from the FTP server.
2	Switches the UART to data mode and accepts a stream of data terminated by an [ETX] character. This mode is used for uploading files to the FTP server.

<mode>:	File Transfer Mode
5	Switches the UART to data mode and accepts a stream of data terminated by an [ETX] character. This mode is used for uploading files using the FTP APPEND method.

<filename>:	Filename
String type	Specifies the name of the file to upload or download in FTP. The maximum file length is limited to 128 characters; and the actual filename including the path name has to be used.

<dle_mode>:	Continuous/Continuous Transparent Configuration Mode
0 (default)	Configures the file to be uploaded/downloaded in continuous mode.
1	Configures the file to be uploaded/downloaded in continuous transparent mode.

9.5.1.6. Parameter Storage

None

9.5.1.7. Possible Errors

The possible error message is displayed only if “AT+CMEE=1” is activated. Otherwise, only “ERROR” is displayed.

“+CMEE” AT Error Code	Description
800	invalid option
801	invalid option value
803	operation not allowed in the current WIP stack state
830	bad index
831	bad state
834	not implemented
836	memory allocation error
837	bad protocol
839	error during channel creation
846	Internal error
860	protocol undefined or internal error
890	service denied
891	message format corrupt
892	address unresolved
893	message not found
894	network problem
895	content not accepted
896	unsupported message
897	unspecified error

9.5.1.8. Examples

Command	Responses
AT+WIPFILE=4,1,1,"data.bin" Note: Download file in continuous mode	CONNECT <data received terminated by [ETX] character> OK
AT+WIPFILE=4,1,2,"report.log" Note: Upload file in continuous mode	CONNECT <data terminated by [ETX] character> OK
AT+WIPFILE=4,1,5,"report.log" Note: Upload file in continuous mode; data will be added at the end of file	CONNECT <data terminated by [ETX] character> OK
AT+WIPFILE=4,1,1,"data.bin",1 Note: Download file in continuous transparent mode	CONNECT <data> +++ OK Note: The +++ sequence causes the UART to switch to AT mode
AT+WIPFILE=4,1,2,"report.log",1 Note: Upload file in continuous transparent mode	CONNECT <data> +++ OK Note: The +++ sequence causes the UART to switch to AT mode
AT+WIPFILE=4,1,1,"data.bin",0 Note: Download file in continuous mode	CONNECT <data received terminated by [ETX] character> OK
AT+WIPFILE=4,1,2,"report.log",0 Note: Upload file in continuous mode	CONNECT <data terminated by [ETX] character> OK

9.5.1.9. Notes

This command returns CONNECT and enters Data Mode when executed correctly; it returns OK when quitted from Data Mode.

This command is available when the module has finished its initialization; and it is functional when an FTP session has been created successfully using the +WIPCREATE command.

9.5.2. Socket Data Exchange +WIPDATA



9.5.2.1. Description

The +WIPDATA command is used to read/write from/to a socket. On successful execution of the command, the UART switches to data mode. The UART can be switched back to AT mode by sending “+++” with 1 second guard time before and after the sequence. If data is not read using +WIPDATA command, further data will be delayed.

An unsolicited event is received when there is data to read on a socket.

Data can be sent on the sockets using two modes:

- continuous mode
- continuous transparent mode

9.5.2.2. Continuous Mode

9.5.2.2.1. TCP Sockets in Continuous Mode

In continuous mode, an [ETX] character is considered as an end of data. When an [ETX] character is sent on the UART, the TCP socket is shutdown and the peer side is informed of this shutdown with the indication “[CR][LF]SHUTDOWN[CR][LF]” on the UART.

In case an [ETX]/[DLE] character needs to be transmitted as data, it should be preceded by a [DLE] character. Similarly, [ETX]/[DLE] characters received by the TCP/IP stack from the internet are sent to the host through the serial port preceded by a [DLE] character.

To close sockets, switch the UART to AT command mode and use the +WIPCLOSE command.

9.5.2.2.2. UDP Sockets in Continuous Mode

UDP is a connectionless protocol and hence there is no way to detect or cause a shutdown. However, an [ETX] character is used to mark the boundaries of datagrams.

All data written on a UDP socket is collected till an [ETX] character is encountered or the maximum size of the datagram¹ is reached and will be sent as a single datagram. Similarly when reading data, all data will be read till an [ETX] character is encountered which indicates the end of the datagram. Note that, in this mode, packet segmentation feature is not supported.

In case an [ETX]/[DLE] character needs to be transmitted, it should be preceded by a [DLE] character similar to the TCP socket.

When the UART leaves DATA mode, either because of a “+++” escape sequence or because of an AT+WIPDATA=1, index, 0 on another UART, the currently unsent data is sent as a single datagram.

¹ The maximum size of a UDP datagram has been fixed to 5904 Bytes. This limit is an arbitrary one. Note that when the UDP datagram sent is bigger than 5904 Bytes, the whole datagram will be discarded by the WS6318 module. Also note that the smaller the datagram is, the more certain it will reach the aimed destination. UDP is a non-reliable transport layer.

9.5.2.2.3. [ETX] Escaping Mechanism

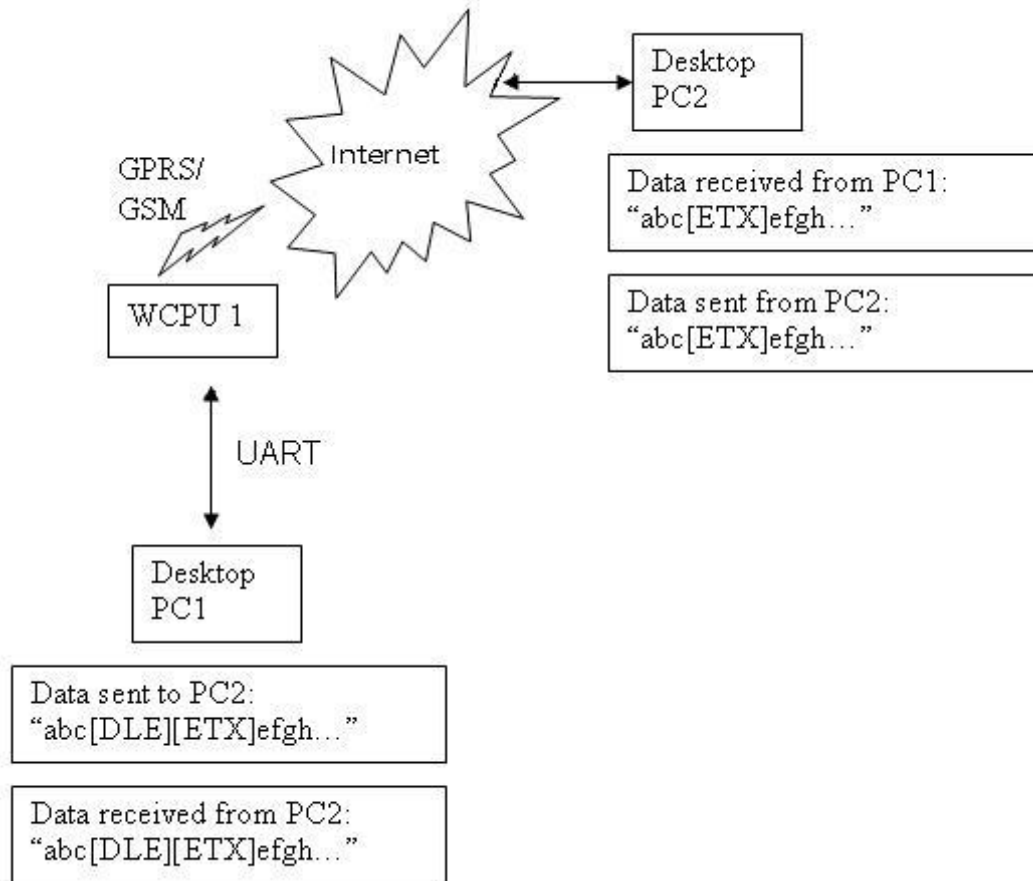

The schematic above explains how [ETX] characters – which have a special meaning in the firmware – are handled on the WS6318.

On the transmitting side, when [ETX] are not escaped (use case: Desktop PC1 sends data towards the WS6318. Data contains a non escaped [ETX] (⇔ no [DLE][ETX] sequence), then the [ETX] is not transmitted but an action is done on the WS6318 regarding the concerned socket:

- UDP socket: a non escaped [ETX] marks the boundary of the current datagram to be sent. Datagram is immediately sent and the [ETX] is not sent towards the desktop PC2.
- TCP socket: a non escaped [ETX] causes a TCP shutdown operation on the transmitting direction: peer is informed that the WS6318 will not send any more data on that socket. Usually, peer will shutdown the other way (downlink) and this will result in a “peer close event” on the socket.

On the receiving side, when [ETX] are not escaped (use case: the WS6318 sends data towards Desktop PC1. Data contains a non escaped [ETX] (⇔ no [DLE][ETX] sequence), then the [ETX] means that a special “IP” event occurred on the WS6318 regarding the concerned socket:

- UDP socket: a non escaped [ETX] signals the boundary of the current received datagram.
- TCP socket: a non escaped [ETX] signals that the peer TCP connected to the TCP unit has shutdown (through the downlink way). Desktop PC1 should then close the uplink socket to totally terminate the TCP “session”.

Protocol	UART	IP Network (Active Socket)
UDP	Data containing a [DLE][ETX] sequence.	Data containing an [ETX].

Protocol	UART	IP Network (Active Socket)
UDP	[ETX] alone.	Mark the boundary of the UDP Datagram received/to be transmitted.
TCP	Data containing a [DLE][ETX] sequence.	Data containing an [ETX].
TCP	[ETX] alone.	Causes/signals a shutdown operation on TCP socket.

Note: The behaviour is symmetrical in the sense that it applies both on the transmitting and the receiving side of the UART.

9.5.2.2.4. [DLE] Escaping Mechanism

A [DLE] character will be sent as data only when it is preceded by another [DLE] character. A single [DLE] character which is not preceded by a [DLE] character will not be transmitted.

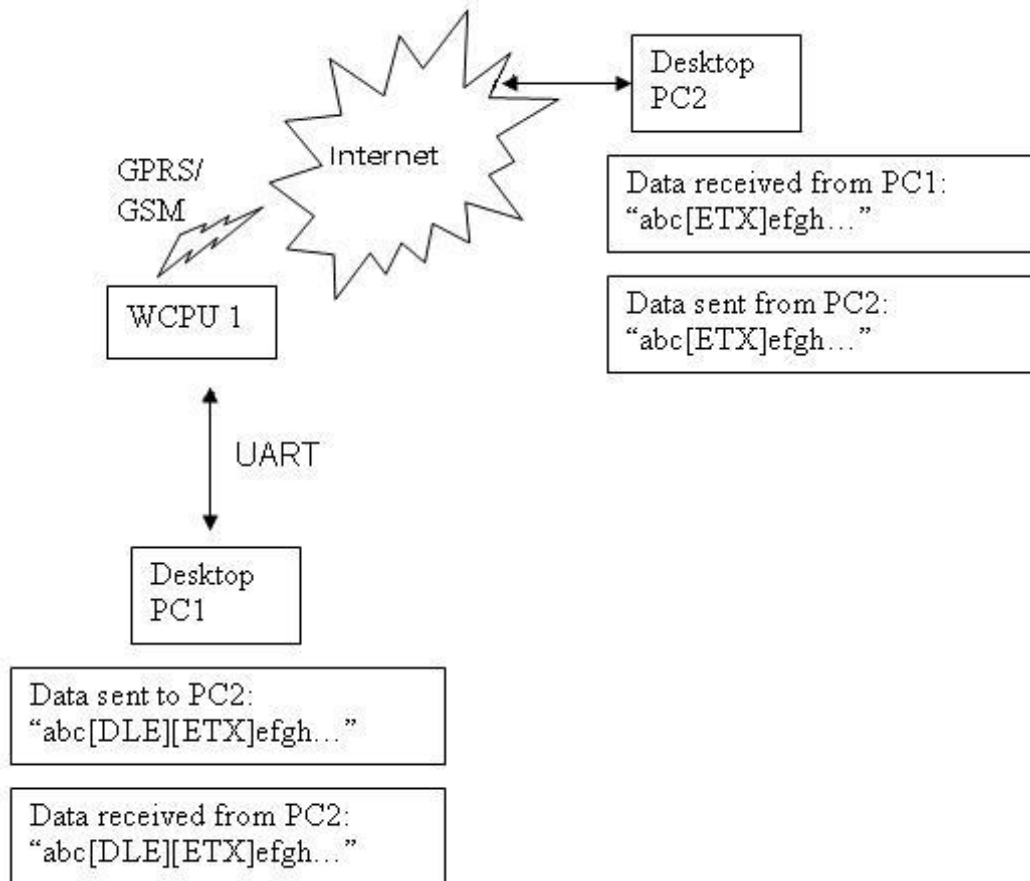

The schematic above explains how [DLE] characters – which have a special meaning in the firmware – are handled on the WS6318.

On the transmitting side, when a [DLE] is not escaped (use case: Desktop PC1 sends data towards the WS6318. Data contains a non escaped [DLE] (⇔ no [DLE][DLE] sequence), then the [DLE] is not transmitted.

On the transmitting side, when a [DLE] is escaped (use case: Desktop PC1 sends data towards the WS6318. Data contains an escaped [DLE] (⇔ [DLE][DLE] sequence), then the [DLE] data is transmitted.

On the receiving side (use case: when Desktop PC2 sends data towards the WS6318. Data contains an escaped [DLE]), the data sent from the WS6318 to Desktop PC1 will contain an escaped [DLE] preceding the [DLE] character (Desktop PC1 receives the [DLE][DLE] character from the WS6318).

The scenario is the same for both TCP and UDP sockets.

Protocol	UART	IP Network (Active Socket)
UDP	Data containing a [DLE][DLE] sequence.	Data containing [DLE].
UDP	[DLE] alone.	A single [DLE] is ignored.
TCP	Data containing a [DLE][DLE] sequence.	Data containing [DLE].
TCP	[DLE] alone.	A single [DLE] is ignored.

9.5.2.3. Continuous Transparent Mode

9.5.2.3.1. TCP Sockets in Continuous Transparent Mode

In this mode there is no special meaning associated for [DLE]/[ETX] characters. They are considered as normal data and all the data will be transmitted on the UART.

9.5.2.3.2. UDP Sockets in Continuous Transparent Mode

In this mode there is no special meaning associated for [DLE]/[ETX] characters. They are considered as normal data and all data will be transmitted on the UART. In case a [ETX]/[DLE] character is received, it will not be preceded by a [DLE] character before sending it to the UART.

9.5.2.3.3. Leaving Continuous/Continuous Transparent Mode

The UART can be switched back to AT mode by sending “+++” with 1 second guard time before and after the sequence.

When the UART leaves data mode because of the “+++” escape sequence, the currently unsent data is sent as a single datagram.

9.5.2.4. Resetting TCP Sockets

A TCP socket is reset when the connection is aborted due to an error on the socket. When the socket is reset, an [ETX] character is sent on the UART to indicate the end of communication. The UART switches to AT mode and “+CME ERROR: 843” is displayed on the UART.

9.5.2.5. Syntax

```

Action Command
AT+WIPDATA=<protocol>,<idx>,<mode>[,<send size>,<wait time>]
CONNECT
    
```

<p><i>Read Command</i></p> <p>AT+WIPDATA?</p> <p>NONE</p>
<p><i>Test Command</i></p> <p>AT+WIPDATA=?</p> <p>OK</p>

if <protocol> = 1

<p><i>Unsolicited response</i></p> <p>+WIPDATA: <protocol>,<idx>,<datagram size>,<peer IP>,<peer port></p>
--

Caution: Using AT+WIP AT commands, when receiving several UDP datagrams on an IP bearer, +WIPDATA indication is sent once for the first received datagram. Next indication (for next remaining UDP datagram to read) is sent once the first datagram have been read (using +WIPDATA command).

if <protocol> = 2

<p><i>Unsolicited response</i></p> <p>+WIPDATA: <protocol>,<idx>,<number of readable bytes></p>

Caution: The value returned by <number of readable bytes> indicates that there is some TCP data ready to be read but number of bytes returned might not be reliable. Moreover, using AT+WIP AT commands, when receiving several TCP packets on an IP bearer, +WIPDATA indication is sent once for the first received packet. The next indication (for the next remaining TCP packet to read) is sent after the first packet has been read (using +WIPDATA command).

9.5.2.6. Parameters and Defined Values

<protocol>:	socket type
1	UDP
2	TCP client

<idx>:	Definition
	socket identifier

<mode>:	mode of operation
1	continuous: switch the UART to data mode.
2	continuous transparent: switch the UART to data mode. In this mode, [DLE]/[ETX] characters are considered as normal data and not special characters.

<send size>:	Definition
range: 8-1460 (default value: 1020)	Data packet size: This parameter specifies the size of the data packet that needs to be sent to the peer. This parameter is supported only for UDP continuous transparent mode.

<wait time>:	Definition
range: 1-100 (default value: 2) unit: second	Timeout for configuring the packet segmentation on the IP network side: This parameter specifies the timeout after which the buffered data will be sent to the peer, irrespective of size of the data packet. This parameter is only supported for UDP continuous transparent mode.

9.5.2.7. Parameter Storage

None

9.5.2.8. Possible Errors

The possible error message is displayed only if “AT+CMEE=1” is activated. Otherwise, only “ERROR” is displayed.

“+CMEE” AT Error Code	Description
831	bad state
837	bad protocol
843	connection reset by peer

9.5.2.9. Examples

Command	Responses
<p>AT+WIPDATA=2,5,1</p> <p>Note: TCP Client with index 5 can send/read data in continuous mode.</p>	<p>CONNECT</p> <p><read/write data></p> <p>+++</p> <p>OK</p> <p>Note: +++ sequence causes the UART to switch to AT mode.</p>
<p>AT+WIPDATA=2,5,1,10,5</p> <p>Note: TCP Client with index 5 can send/read data in continuous mode</p>	<p>CONNECT</p> <p><read/write data></p> <p>+++</p> <p>OK</p> <p>Note: +++ sequence causes the UART to switch to AT mode</p>
<p>AT+WIPDATA=1,5,1</p> <p>Note: UDP with index 5 can send/read data in continuous mode</p>	<p>CONNECT</p> <p><read/write data></p> <p>+++</p> <p>OK</p> <p>Note: +++ sequence causes the UART to switch to AT mode</p>

Command	Responses
<p>AT+WIPDATA=1,5,1 Note: UDP with index 5 can send/read data in continuous mode</p>	<p>CONNECT <read/write data> <ETX> OK Note: [ETX] character indicates end of data</p>
<p>AT+WIPDATA=1,5,2 Note: UDP with index 5 can send/read data in continuous transparent mode with default value set for <send size> and <wait time></p>	<p>CONNECT <read/write data> +++ OK Note: +++ sequence causes the UART to switch to AT mode</p>
<p>AT+WIPDATA=1,5,2,20,2 Note: UDP with index 5 can send/read data in continuous transparent mode with <send size> set to 20 and <wait time> set to 2</p>	<p>CONNECT <read/write data> +++ OK Note: +++ sequence causes the UART to switch to AT mode</p>
<p>AT+WIPDATA=2,5,1,20,10 Note: TCP with index 5 can send/read data in continuous mode with <send size> set to 20 and <wait time> set to 10</p>	<p>CONNECT <read/write data> +++ OK Note: +++ sequence causes the UART to switch to AT mode</p>
<p>AT+WIPDATA=2,5,2,10,5 Note: TCP with index 5 can send/read data in continuous transparent mode with <send size> set to 10 and <wait time> set to 5</p>	<p>CONNECT <read/write data> +++ OK Note: +++ sequence causes the UART to switch to AT mode</p>
<p>AT+WIPDATA=2,5,2 Note: TCP with index 5 can send/read data in continuous transparent mode</p>	<p>CONNECT <read/write data> +++ OK Note: +++ sequence causes the UART to switch to AT mode</p>

9.5.2.10. Notes

9.5.2.10.1. Continuous Mode (Non-Transparent) for a TCP Mapped Socket

If the [ETX] character is sent from the peer, it is considered as an end of data transfer. After sending an [ETX] character, the socket will be shutdown and the peer will be informed of this shutdown by a “[CR][LF]SHUTDOWN[CR][LF]” indication on its UART and the UART will not switch to AT mode. This indicates that no more data can be sent from the host socket, but it can receive data. The schematic below shows the shutdown procedure for a TCP socket:

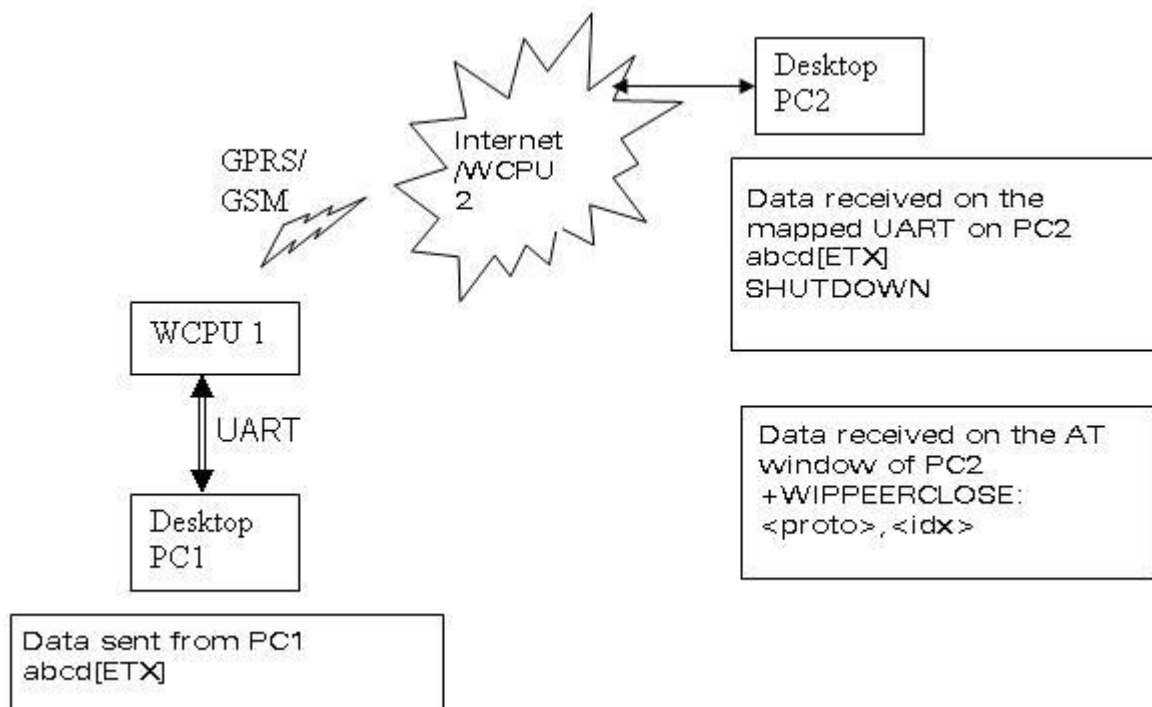

In the schematic above, a TCP socket is connected. On the transmitting side, data and [ETX] is sent (use case: Desktop PC1 is a WS6318 which sends data to PC2 which is either a PC or also a WS6318), and the data is received on PC2 and the [ETX] character shuts down the socket on the transmitting side and displays a message “[CR][LF]SHUTDOWN[CR][LF]” on the UART of PC2.

When PC2 is switched back to AT mode, “+WIPPEERCLOSE: <protocol>, <idx>” indication is received indicating that no more data can be sent by PC1 but can read data sent from PC2.

There are different indications received for shutdown and reset for a TCP socket. When a TCP socket is reset, [ETX] character is sent on the UART to indicate the end of communication. The UART switches to AT mode and “+CME ERROR: 843” is displayed on the UART. The reset and shutdown can therefore be distinguished by the indications received on the UART.

9.5.2.10.2. Mapping/Unmapping of a Mapped UDP and TCP Socket

When a TCP socket is unmapped and still active, it is possible to map it again in another mode which is different from the previous one without closing the TCP socket.

The UART switches back to AT mode due to the “+++” with 1 second guard time before and after the sequence or by sending an `AT+WIPDATA=<proto>,<index>,0` on another UART in AT mode. This applies to both UDP and TCP protocols.

When +++ is issued, the WS6318 switches from DATA mode to AT mode. If ATO command is used to switch the WS6318 back to DATA mode, and:

- +CME ERROR:3 will be received when GPRS bearer is used
- no response is received when GSM bearer is used

To switch the WS6318 back to DATA mode, AT+WIPDATA=x,x,x should be used instead of ATO. After executing the AT+WIPDATA=x,x,x command, "CONNECT" will be received to indicate that the WS6318 is switched back to DATA mode.

Note that un-mapping a socket using the +WIPDATA command with <send size> and <wait time> specified results in "ERROR".

9.5.2.10.3. Time Out Mechanisms to Know the State of the Peer TCP Socket

In a TCP server-client connection between two remote devices, if the peer socket is closed down abruptly (e.g. powered off) the peer TCP socket does not get any indication message. This is normal behavior. The TCP protocol uses a timeout mechanism to check the state of the TCP sockets in a TCP socket connection. According to this mechanism, to know the state of the peer TCP socket, the data needs to be sent and wait for the acknowledgement within a specified time period. If the acknowledgement is not received within the specified time out period then the data is retransmitted. But if the time out occurs before receiving the acknowledgement then it implies that the peer TCP socket is closed.

TCP Timeout Period = function (R, N)

Where,

R = Round trip time. This is the time for a TCP packet to go to the remote TCP socket and the time to receive the acknowledgement by the transmitter TCP socket. The typical round trip time is 1 second for GPRS.

N = Number of retransmissions allowed before the time out happens.

Hence, the typical timeout period is 10 minutes depending on the network and also the peer TCP socket localization.

Data needs to be sent to know the state of the peer socket. If acknowledgement is not received within the timeout period then "+CME ERROR: 842" is returned. This indicates that the peer socket is closed.

Please note that the retransmission of the data to the peer TCP socket within the timeout period is managed by the TCP/IP stack.

9.5.2.10.4. Packet Segmentation in TCP Socket

The parameters used for packet segmentation can be configured using the +WIPDATA or the +WIPCFG command. If it is not configured using the +WIPDATA command, then the values already set for option WIP_NET_OPT_TCP_MIN_MSS and AT_WIP_NET_OPT_PREF_TIMEOUT_VALUE will be used.

Note: Any attempt made to set the data packet size to more than twice the value of WIP_NET_OPT_TCP_MIN_MSS using the +WIPDATA command results in "+CME ERROR: 847".

The data sent to a mapped TCP socket through the UART will be buffered before being sent to the peer. This buffered data will be sent to the peer when the:

- total amount of buffered data is twice or more than the preferred segmentation size. The preferred segmentation size is configurable through the "AT+WIPCFG = 2, 4, <size>" (WIP_NET_OPT_TCP_MIN_MSS) or the +WIPDATA command.

- internal timer expires. The timeout period is configurable through the “AT+WIPCFG = 2,12,<time>” (AT_WIP_NET_OPT_PREF_TIMEOUT_VALUE) or +WIPDATA command.
- socket is unmapped, shut down or closed.

In some scenarios, there might be a segmentation of data packets because of timer expiration, network problems, etc. Thus, a single packet of data may be received in more than one packet at the peer.

9.5.2.10.5. Packet Segmentation in UDP Sockets

This feature for UDP is supported only in case of continuous transparent mode. If the +WIPDATA command is executed in continuous mode to use this feature, “ERROR” will be returned. The parameters used for packet segmentation can be configured using the +WIPDATA command. In case they are not configured using the +WIPDATA command, the default value of these parameters will be used.

In some scenarios, there might be a segmentation of data packets because of timer expiration, network problems, etc. Thus, a single packet of data may be received in more than one packet at the peer.

9.6. Ping Services

9.6.1. PING command +WIPPING



9.6.1.1. Description

The +WIPPING command is used to configure different PING parameters and to send PING requests. An unsolicited response is displayed each time a “PING” echo event is received or a timeout expires.

9.6.1.2. Syntax

<p><i>Action Command</i></p> <p>AT+WIPPING=<host>, [<repeat>], [<interval>], [<timeout>], [<nwrite>], [<t1>]</p> <p>OK</p>
<p><i>Read Command</i></p> <p>AT+WIPPING?</p> <p>OK</p>
<p><i>Test Command</i></p> <p>AT+WIPPING=?</p> <p>OK</p>

Unsolicited response
 +WIPPING:<timeout_expired>,<packet_idx>,<response_time>

9.6.1.3. Parameters and Defined Values

<host>:	Definition
string	host name or IP address
<repeat>:	Definition
range: 1-65535 (default value:1)	number of packets to send
<interval>:	Definition
range: 1-65535 (default value:2000)	number of milliseconds between packets
<timeout>:	Definition
range: 1-65535 (default value:2000)	number of milliseconds before a packet is considered lost
<ttl>:	Definition
range : 0-255	IP packet Time To Live Default value is set by WIP_NET_OPT_IP_TTL +WIPCFG option
<nwrite>:	Definition
range : 1-1472 (default value:64)	size of user data packets (excluding the 28 bytes IP header + ICMP header)
<timeout_expired>:	PING result
0	PING response received before <timeout>
1	<timeout> expired before the response was received
<packet_idx>:	Definition
	packet index in the sequence

<response_time>:	Definition
	PING response time in millisecond

9.6.1.4. Parameter Storage

None

9.6.1.5. Possible Errors

The possible error message is displayed only if “AT+CMEE=1” is activated. Otherwise, only “ERROR” is displayed.

“+CMEE” AT Error Code	Description
800	invalid option
801	invalid option value
819	error on Ping channel

9.6.1.6. Examples

Command	Responses
<p>AT+WIPING="www.sierrawireless.com" Note: Ping “www.sierrawireless.com”</p>	<p>OK +WIPING: 1,0,0 Note: Ping “www.sierrawireless.com failed : timeout expired.</p>
<p>AT+WIPING="192.168.0.1" Note: Ping "192.168.0.1"</p>	<p>OK +WIPING: 0,0,224 Note: Ping “192.168.0.1 succeeded. Ping response received in 224ms.</p>
<p>AT+WIPING="192.168.0.1",2,2000,1000 Note: Send 2 successive ping requests to "192.168.0.1". Each Ping is 2000 ms, timeout is set to 1000 ms (if ping response time is more than 1000 ms, then timeout expires).</p>	<p>OK +WIPING: 0,0,880 +WIPING: 1,1,xxxx Note: Ping “192.168.0.1 succeeded. First Ping response received in 880 ms. Second one was not received before specified timeout (1000 ms) ⇔ timeout expired.</p>

9.7. Examples of Application

9.7.1. TCP Socket

9.7.1.1. TCP Server Socket

9.7.1.1.1. Using GPRS Bearer

```

AT+WIPCFG=1 //start IP stack
OK
AT+WIPBR=1,6 //open GPRS bearer
OK
AT+WIPBR=2,6,11,"APN name" //set APN name of GPRS bearer
OK
AT+WIPBR=2,6,0,"user name" //set user name (<login>)
OK
AT+WIPBR=2,6,1,"passwd" //set password (<password>)
OK
AT+WIPBR=4,6,0 //start GPRS bearer
OK
AT+WIPCREATE=3,1,80,5,8 //create the server on port 80, idx = 1. The
OK //server is listening for connection request on
//port 80.
//Spawned sockets will be given the index 5, 6,
//7 and 8.
//It will accept connection request until it has no
//more sockets left.
+WIPACCEPT: 1,5 //unsolicited: the server accepted a connection
//resulting TCP client on idx 5.
AT+WIPDATA=2,5,1 //exchange data on socket index 5
CONNECT
... //read, write
+++ //switch to AT mode
OK
AT+WIPCLOSE=2,5 //close the TCP client socket index 5
OK

```

9.7.1.1.2. Using GSM Bearer

```
AT+WIPCFG=1 //start IP stack
OK
AT+WIPBR=1,5 //open GSM bearer
OK
AT+WIPBR=2,5,2,"Phone number" //set phone number for GSM bearer
OK
AT+WIPBR=2,5,0,"user name" //set user name
OK
AT+WIPBR=2,5,1,"passwd" //set password
OK
AT+WIPBR=4,5,0 //start GSM bearer
OK
AT+WIPCREATE=3,1,80,5,8 //create the server on port 80, idx = 1. The
//server is listening for connection request on
//port 80.Spawned sockets will be given the
//index 5, 6, 7 and 8. It will accept connection
//request until it has no more sockets left.
+WIPACCEPT: 1,5 //unsolicited: the server accepted a connection
//resulting TCP client on idx 5
AT+WIPDATA=2,5,1 //exchange data on socket idx 5
CONNECT
... //read, write
+++ //switch to AT mode
OK
AT+WIPCLOSE=2,5 //close the TCP client socket index 5
OK
```

9.7.2. TCP Client Socket

9.7.2.1.1. Using GPRS Bearer

```

AT+WIPCFG=1 //start IP stack
OK
AT+WIPBR=1,6 //open GPRS bearer
OK
AT+WIPBR=2,6,11,"APN name" //set APN name of GPRS bearer
OK
AT+WIPBR=2,6,0,"user name" //set user name
OK
AT+WIPBR=2,6,1,"passwd" //set password
OK
AT+WIPBR=4,6,0 //start GPRS bearer
OK
AT+WIPCREATE=2,1,"ip addr",80 //create a TCP client towards peer IP device
//@ "ip addr", port 80.
OK //all parameters and iP stack behavior are OK.
+WIPREADY: 2,1 //unsolicited: the TCP client socket is
//connected to the peer
AT+WIPDATA=2,1,1 //exchange data on socket idx 1:
CONNECT
... //read, write
+++ //switch to AT mode
OK
AT+WIPCLOSE=2,1 //close the TCP client socket index 1
OK

```

9.7.2.1.2. Using GSM Bearer

```

AT+WIPCFG=1 //start IP stack
OK
AT+WIPBR=1,5 //open GSM bearer
OK
AT+WIPBR=2,5,2,"Phone number" //set phone number for GSM bearer
OK
AT+WIPBR=2,5,0,"user name" //set user name
OK
AT+WIPBR=2,5,1,"passwd" //set password
OK
AT+WIPBR=4,5,0 //start GSM bearer
OK
AT+WIPCREATE=2,1,"ip addr",80 //create a TCP client towards peer IP device
//@ "ip addr", port 80
OK //all parameters and IP stack behavior are OK
+WIPREADY: 2,1 //unsolicited: the TCP client socket is
//connected to the peer
AT+WIPDATA=2,1,1 //exchange data on socket idx 1
CONNECT
... //read, write
+++ //switch to AT mode
OK
AT+WIPCLOSE=2,1 //close the TCP client socket index 1
OK

```

9.7.3. UDP Socket

```

AT+WIPCFG=1 //start IP stack
OK
AT+WIPBR=1,6 //open GPRS bearer
OK
AT+WIPBR=2,6,11,"APN name" //set APN name of GPRS bearer
OK
AT+WIPBR=2,6,0,"user name" //set user name
OK
AT+WIPBR=2,6,1,"passwd" //set password
OK
AT+WIPBR=4,6,0 //start GPRS bearer
OK
AT+WIPCREATE=1,1,80,"www.sierrawireless.com",80 //create a UDP client towards peer IP device @
//"www.sierrawireless.com", port 80
OK //all parameters and IP stack behavior are OK

+WIPREADY: 1,1 //unsolicited: the UDP client socket is "pseudo"
//connected to the peer (no real connection is
//UDP)

AT+WIPDATA=1,1,1 //exchange data on socket idx 1:
CONNECT
... //read, write
+++ //switch to AT mode
OK
AT+WIPCLOSE=1,1 //close the UDP socket index 1
OK
AT+WIPCREATE=1,1,1234 //start a UDP server and listen for datagram on
//port 1234
OK //all parameters and IP stack behavior are OK

+WIPREADY: 1,1 //unsolicited: the UDP client socket is "pseudo"
//connected to the peer (no real connection is
//UDP)

```

```

+WIPDATA: 1,1,25,"192.168.0.2",2397 //one datagram is ready to be read : it was sent
//from 192.168.0.2 on port 2397 and is
//composed of 25 bytes

AT+WIPDATA=1,1,1

CONNECT

abcdedghijklmnopqrstuvwxyz [ETX] //here 25 bytes + the [ETX] character (marking
//the bound of the datagram) have been read.

OK //here UART is back to AT command mode. If
//some other remote IP devices sent one or
//more datagrams while reading for the first one,
//then a new datagram indication is received

+WIPDATA: 1,1,50,"192.168.0.4",58 //one datagram is ready to be read : it was sent
//from 192.168.0.4 on port 58 and is composed
//of 50 bytes

AT+WIPDATA=1,1,1

CONNECT

abcdedghijklmnopqrstuvwxyzabcdedghijklm //here 25 bytes + the [ETX] character (marking
nopqrstuvwxyz [ETX] //the bound of the datagram) have been read.

```

9.7.4. PING

```

AT+WIPCFG=1 //start IP stack
OK

AT+WIPBR=1,6 //open GPRS bearer
OK

AT+WIPBR=2,6,11,"APN name" //set APN name of GPRS bearer
OK

AT+WIPBR=2,6,0,"user name" //set user name
OK

AT+WIPBR=2,6,1,"passwd" //set password
OK

AT+WIPBR=4,6,0 //start GPRS bearer
OK

AT+WIPPING="192.168.0.1" //start PING session
OK
+WIPPING:0,0,224

```

9.7.5. Creating a TCP Server, Spawning the Maximum TCP Sockets (for the Configured Server)

```

AT+WIPCFG=1 //start IP stack
OK
AT+WIPBR=1,6 //open GPRS bearer
OK
AT+WIPBR=2,6,11,"APN name" //set APN name of GPRS bearer
OK
AT+WIPBR=2,6,0,"user name" //set user name
OK
AT+WIPBR=2,6,1,"passwd" //set password
OK
AT+WIPBR=4,6,0 //start GPRS bearer
OK
AT+WIPCREATE=3,1,80,5,6 //create the server on port 80, idx = 1. The
OK //server is listening for connection request
//on port 80.Spawnd sockets will be given
//the index 5 or 6. It will accept connection
//request until it has no more socket left.
+WIPACCEPT: 1,5 //unsolicited: the server accepted a
//connection resulting TCP client on idx 5.
+WIPACCEPT: 1,6 //unsolicited: the server accepted a
//connection resulting TCP client on idx 6.
AT+WIPCLOSE=2,5 //close the spawned TCP client socket index
//5.
OK //now if the peer device try to connect to the
//server it shall receive an accept ()
//immediately followed by an shutdown()
//(connection reset by peer)

```

9.7.6. Creating a Server and Trying to Create a TCP Client/Server on a Reserved Index (reserved by the Server) will Fail

```

AT+WIPCFG=1 //start IP stack
OK
AT+WIPBR=1,6 //open GPRS bearer
OK
AT+WIPBR=2,6,11,"APN name" //set APN name of GPRS bearer
OK
AT+WIPBR=2,6,0,"user name" //set user name
OK
AT+WIPBR=2,6,1,"passwd" //set password
OK
AT+WIPBR=4,6,0 //start GPRS bearer
OK
AT+WIPCREATE=3,2,80,1,2 //create the server on port 80, idx=2. The
OK //server is listening for connection request
//on port 80. Spawned sockets will be given
//the index 1 or 2.It will accept connection
//request until has nor more socket left.

AT+WIPCREATE=2,3,"198.168.0.1",80 //create a TCP client towards peer IP device
OK //@"198.168.0.1", port 80,
//all parameters and IP stack behavior are
//OK.

+WIPREADY: 2,3 //unsolicited: the TCP client socket is
//connected to the peer.

+WIPACCEPT: 2,1 //unsolicited: the server index accepted a
//connection; resulting TCP client on idx 1

AT+WIPDATA=2,3,1 //exchange data on socket index 3
CONNECT

AT+WIPDATA=2,1,1 //exchange data on socket index 1
CONNECT

[ETX] //send unescaped ETX character

+WIPPEERCLOSE: 2,3 //unsolicited: peer socket is closed

```

```

AT+WIPCLOSE=3,1 //close TCP server socket index 1
OK
AT+WIPCREATE=3,2,81,2,3 //create the server on port 81, idx=2 and
//from_idx=2 and to_idx=3

+CME ERROR:845 //TCP client socket with idx 2 was reserved
//by the previous server socket and it was
//not closed explicitly. Hence error is
//returned.

```

9.7.7. Failed Creation of a TCP Client and Failed Creation of a TCP Server with Index Range Containing a TCP Client

```

AT+WIPCFG=1 //start IP stack
OK
AT+WIPBR=1,6 //open GPRS bearer
OK
AT+WIPBR=2,6,11,"APN name" //set APN name of GPRS bearer
OK
AT+WIPBR=2,6,0,"user name" //set user name
OK
AT+WIPBR=2,6,1,"passwd" //set password
OK
AT+WIPBR=4,6,0 //start GPRS bearer
OK
AT+WIPCREATE=2,1,"198.168.0.1",80 //create a TCP client towards peer IP device
//@ "198.168.0.1", port 80
OK //all parameters and IP stack behavior are
//OK.

+WIPREADY: 2,1 //unsolicited: the TCP client socket is
//connected to the peer.

AT+WIPCREATE=3,2,80,1,2 //create the server on port 80, idx=2. Range
//requested contains the already used index
//"1" and hence error is returned.
+CME ERROR: 845

```

9.7.8. Creating 8 UDP Sockets, 8 TCP Clients and 4 TCP Servers

```

AT+WIPCFG=1 //start IP stack
OK
AT+WIPBR=1,6 //open GPRS bearer
OK
AT+WIPBR=2,6,11,"APN name" //set APN name of GPRS bearer
OK
AT+WIPBR=2,6,0,"user name" //set user name
OK
AT+WIPBR=2,6,1,"passwd" //set password
OK
AT+WIPBR=4,6,0 //start GPRS bearer
OK
AT+WIPCREATE=1,1,55,"192.168.0.1",75 //create a UDP client towards peer IP
//device @ "192.168.0.1", port 75.
OK //all parameters and IP stack behavior are
//OK.
+WIPREADY: 1,1 //unsolicited: the UDP client socket is
//"pseudo" connected to the peer (no real
//connection in UDP)
AT+WIPCREATE=1,2,56,"192.168.0.1",76 //create a UDP client towards peer IP
//device @ "192.168.0.1", port 76.
OK //all parameters and IP stack behavior are
//OK.
+WIPREADY: 1,2 //unsolicited: the UDP client socket is
//"pseudo" connected to the peer (no real
//connection is UDP)
AT+WIPCREATE=1,3,57,"192.168.0.1",77 //create a UDP client towards peer IP
//device @ "192.168.0.1", port 77.
OK //all parameters and IP stack behavior are
//OK.
+WIPREADY: 1,3 //unsolicited: the UDP client socket is
//"pseudo" connected to the peer (no real
//connection is UDP)
AT+WIPCREATE=1,4,58,"192.168.0.1",78 //create a UDP client towards peer IP
//device @ "192.168.0.1", port 78.

```

OK	//all parameters and IP stack behavior are //OK
+WIPREADY: 1,4	//unsolicited: the UDP client socket is //“pseudo” connected to the peer (no real //connection in UDP)
AT+WIPCREATE=1,5,59,"192.168.0.1",79	//create a UDP client towards peer IP //device @ “192.168.0.1”, port 79.
OK	//all parameters and IP stack behavior are //OK
+WIPREADY: 1,5	//unsolicited: the UDP client socket is //“pseudo” connected to the peer (no real //connection in UDP)
AT+WIPCREATE=1,6,60,"192.168.0.1",80	//create a UDP client towards peer IP //device @ “192.168.0.1”, port 80.
OK	//all parameters and IP stack behavior are //OK
+WIPREADY: 1,6	//unsolicited: the UDP client socket is //“pseudo” connected to the peer (no real //connection in UDP)
AT+WIPCREATE=1,7,61,"192.168.0.1",81	//create a UDP client towards peer IP //device @ “192.168.0.1”, port 81
OK	//all parameters and IP stack behavior are //OK
+WIPREADY: 1,7	//unsolicited: the UDP client socket is //“pseudo” connected to the peer (no real //connection in UDP)
AT+WIPCREATE=1,8,62,"192.168.0.1",82	//create a UDP client towards peer IP //device @ “192.168.0.1”, port 82.
OK	//all parameters and IP stack behavior are //OK
+WIPREADY: 1,8	//unsolicited: the UDP client socket is //“pseudo” connected to the peer (no real //connection in UDP)
AT+WIPCREATE=1,9,63,"192.168.0.1",83	
+CME ERROR: 830	//8 UDP sockets have been created and //hence 9 th attempt fails
AT+WIPCREATE=3,1,80,1,1	//create one server on port 80, idx = 1. One //TCP client socket is reserved on index 1
OK	

AT+WIPCREATE=3,2,81,2,2 OK	//create one server on port 81, idx = 2. One //TCP client socket is reserved on index 2
AT+WIPCREATE=3,3,82,3,3 OK	//create one server on port 82, idx = 3. One //TCP client socket is reserved on index 3
AT+WIPCREATE=3,4,83,4,4 OK	//create one server on port 83, idx = 4. One //TCP client socket is reserved on index 4
AT+WIPCREATE=3,5,84,5,5 +CME ERROR: 830	//4 TCP servers have been created and //hence creation of 5 th TCP server socket //fails
AT+WIPCREATE=2,1,"192.168.0.1",80 +CME ERROR: 845	//create a TCP client socket towards peer IP //device @ "192.168.0.1", port 80. Index 1 is //reserved by server index and hence error //is returned.
+WIPACCEPT: 1,1	//4 reserved TCP client sockets have been //spawned by their TCP server.
+WIPACCEPT: 2,2	//unsolicited: the server index 1 accepted a //connection; resulting TCP client on idx 1
+WIPACCEPT: 3,3	//unsolicited: the server index 2 accepted a //connection; resulting TCP client on idx 2
+WIPACCEPT: 4,4	//unsolicited: the server index 3 accepted a //connection; resulting TCP client on idx 3
AT+WIPCREATE=2,5,"192.168.0.1",80 OK	//unsolicited: the server index 4 accepted a //connection; resulting TCP client on idx 4
+WIPREADY: 2,5	//create a TCP client towards peer IP device //@ "192.168.0.1", port 80.
AT+WIPCREATE=2,6,"192.168.0.1",80 OK	//all parameters and IP stack behavior are //OK
+WIPREADY: 2,6	//unsolicited: the TCP client socket is //connected to the peer.
AT+WIPCREATE=2,7,"192.168.0.1",80 OK	//create a TCP client towards peer IP device //@ "192.168.0.1", port 80.
	//all parameters and IP stack behavior are //OK

```

+WIPREADY: 2,7 //unsolicited: the TCP client socket is
                //connected to the peer

AT+WIPCREATE=2,8,"192.168.0.1",80 //create a TCP client towards peer IP device
                //@ "192.168.0.1", port 80.

OK //all parameters and IP stack behavior are
   //OK

+WIPREADY: 2,8 //unsolicited: the TCP client socket is
                //connected to the peer

AT+WIPCREATE=2,8,"192.168.0.1",80 //create a TCP client towards peer IP device
                //@ "192.168.0.1", port 80. Index 8 is
+CME ERROR: 840 //already used and corresponds to an active
                //socket.

AT+WIPCREATE=2,9,"192.168.0.1",80 //create a TCP client towards a peer IP
                //device @ "192.168.0.1", port 80. Index 9 is
+CME ERROR: 830 //forbidden.

```

9.7.9. Trying to Create 8 UDP Sockets, 8 TCP Client Sockets and 4 TCP Server Sockets

```

AT+WIPCFG=1 //start IP stack
OK

AT+WIPBR=1,6 //open GPRS bearer
OK

AT+WIPBR=2,6,11,"APN name" //set APN name of GPRS bearer
OK

AT+WIPBR=2,6,0,"user name" //set user name
OK

AT+WIPBR=2,6,1,"passwd" //set password
OK

AT+WIPBR=4,6,0 //start GPRS bearer
OK

AT+WIPCREATE=1,1,55,"192.168.0.1",75 //create a UDP client towards peer IP
                //device @ "192.168.0.1", port 75.

OK //all parameters and IP stack behavior are
   //OK.

+WIPREADY: 1,1 //unsolicited: the UDP client socket is
                //"pseudo" connected to the peer (no real
                //connection in UDP)

```

AT+WIPCREATE=1,2,56,"192.168.0.1",76	//create a UDP client towards peer IP //device @ "192.168.0.1", port 76.
OK	//all parameters and IP stack behavior are //OK.
+WIPREADY: 1,2	//unsolicited: the UDP client socket is //"pseudo" connected to the peer (no real //connection in UDP)
AT+WIPCREATE=1,3,57,"192.168.0.1",77	//create a UDP client towards peer IP //device @ "192.168.0.1", port 77.
OK	//all parameters and IP stack behavior are //OK.
+WIPREADY: 1,3	//unsolicited: the UDP client socket is //"pseudo" connected to the peer (no real //connection in UDP)
AT+WIPCREATE=1,4,58,"192.168.0.1",78	//create a UDP client towards peer IP //device @ "192.168.0.1", port 78.
+CME ERROR: 838	//maximum 3 sockets can be created as the //MAX SOCK NUM value has been //changed to 3. Hence an attempt to create //a fourth socket returns error.

9.7.10. Creating TCP Client and Server Sockets in the Same Module

AT+WIPCFG=1	//start IP stack
OK	
AT+WIPBR=1,6	//open GPRS bearer
OK	
AT+WIPBR=2,6,11,"APN name"	//set APN name of GPRS bearer
OK	
AT+WIPBR=2,6,0,"user name"	//set user name
OK	
AT+WIPBR=2,6,1,"passwd"	//set password
OK	
AT+WIPBR=4,6,0	//start GPRS bearer
OK	

```

AT+WIPCREATE=3,2,80,1,2 //create the server on port 80, idx=2. The
OK //server is listening for connection requests
 //on port 80. Spawned sockets will be given
 //the index 1 or 2. It will accept connection
 //request until it has nor more sockets left.

AT+WIPCREATE=2,3,"198.168.0.1",80 //create a TCP client towards peer IP device
 //@ "198.168.0.1", port 80,

OK //all parameters and IP stack behavior are
 //OK.

+WIPREADY: 2,3 //unsolicited: the TCP client socket is
 //connected to the peer.

+WIPACCEPT: 2,1 //unsolicited: the server index accepted a
 //connection; resulting TCP client on idx 1

AT+WIPDATA=2,3,1 //exchange data on socket index 3
CONNECT

abc+++ //data sent to socket index 1 and switched
 //to AT mode by giving +++
OK

AT+WIPDATA=2,1,1 //exchange data on socket index 1
CONNECT
    
```

9.8. Error Codes

“+CMEE” AT Error Code	Description
3	operation not allowed
800	invalid option
801	invalid option value
802	not enough memory
803	operation not allowed in the current TCP/IP stack state
804	device already open
805	network interface not available
806	operation not allowed on the considered bearer
807	bearer connection failure : line busy
808	bearer connection failure : no answer
809	bearer connection failure : no carrier
810	bearer connection failure : no sim card present
811	bearer connection failure : sim not ready (no pin code entered, ...)
812	bearer connection failure : GPRS network failure
813	bearer connection failure : PPP LCP negotiation failed
814	bearer connection failure : PPP authentication failed
815	bearer connection failure : PPP IPCP negotiation failed
816	bearer connection failure : PPP peer terminates session

“+CMEE” AT Error Code	Description
817	bearer connection failure : PPP peer does not answer to echo request
818	incoming call refused
819	error on Ping channel
820	error writing configuration in non-volatile memory
821	error reading configuration in non-volatile memory
822-829	reserved for future use
830	bad index
831	bad state
832	bad port number
833	bad port state
834	not implemented
835	option not supported
836	memory allocation error
837	bad protocol
838	no more free socket
839	error during channel creation
840	UDP/TCP socket or FTP session is already active
841	peer closed or error in the FTP connection
842	destination host unreachable (whether host unreachable, Network unreachable or response timeout)
843	connection reset by peer
844	stack already started
845	attempt is made to reserve/create a client socket which is already reserved/opened by TCP server/client
846	internal error
847	bearer connection failure: WIP_BOPT_GPRS_TIMEOUT time limit expired before GPRS bearer connected
848	impossible to connect to the bearer
849	connection to the bearer has succeeded but a problem has occurred during the data flow establishment
850	unknown reason
851	Incorrect number of parameters submitted
852-859	reserved for future use
860	protocol undefined or internal error
863	protocol delete error
864	protocol list error
869-879	reserved for future use



SIERRA
WIRELESS