



AirPrime HL77xx

Product Technical Specification



SIERRA
WIRELESS®

41110555
2.0
November 01, 2017

Important Notice

Due to the nature of wireless communications, transmission and reception of data can never be guaranteed. Data may be delayed, corrupted (i.e., have errors) or be totally lost. Although significant delays or losses of data are rare when wireless devices such as the Sierra Wireless modem are used in a normal manner with a well-constructed network, the Sierra Wireless modem should not be used in situations where failure to transmit or receive data could result in damage of any kind to the user or any other party, including but not limited to personal injury, death, or loss of property. Sierra Wireless accepts no responsibility for damages of any kind resulting from delays or errors in data transmitted or received using the Sierra Wireless modem, or for failure of the Sierra Wireless modem to transmit or receive such data.

Safety and Hazards

Do not operate the Sierra Wireless modem in areas where cellular modems are not advised without proper device certifications. These areas include environments where cellular radio can interfere such as explosive atmospheres, medical equipment, or any other equipment which may be susceptible to any form of radio interference. The Sierra Wireless modem can transmit signals that could interfere with this equipment. Do not operate the Sierra Wireless modem in any aircraft, whether the aircraft is on the ground or in flight. In aircraft, the Sierra Wireless modem **MUST BE POWERED OFF**. When operating, the Sierra Wireless modem can transmit signals that could interfere with various onboard systems.

Note: Some airlines may permit the use of cellular phones while the aircraft is on the ground and the door is open. Sierra Wireless modems may be used at this time.

The driver or operator of any vehicle should not operate the Sierra Wireless modem while in control of a vehicle. Doing so will detract from the driver or operator's control and operation of that vehicle. In some states and provinces, operating such communications devices while in control of a vehicle is an offence.

Limitations of Liability

This manual is provided "as is". Sierra Wireless makes no warranties of any kind, either expressed or implied, including any implied warranties of merchantability, fitness for a particular purpose, or noninfringement. The recipient of the manual shall endorse all risks arising from its use.

The information in this manual is subject to change without notice and does not represent a commitment on the part of Sierra Wireless. SIERRA WIRELESS AND ITS AFFILIATES SPECIFICALLY DISCLAIM LIABILITY FOR ANY AND ALL DIRECT, INDIRECT, SPECIAL, GENERAL, INCIDENTAL, CONSEQUENTIAL, PUNITIVE OR EXEMPLARY DAMAGES INCLUDING, BUT NOT LIMITED TO, LOSS OF PROFITS OR REVENUE OR ANTICIPATED PROFITS OR REVENUE ARISING OUT OF THE USE OR INABILITY TO USE ANY SIERRA WIRELESS PRODUCT, EVEN IF SIERRA WIRELESS AND/OR ITS AFFILIATES HAS BEEN ADVISED OF THE POSSIBILITY OF SUCH DAMAGES OR THEY ARE FORESEEABLE OR FOR CLAIMS BY ANY THIRD PARTY.

Notwithstanding the foregoing, in no event shall Sierra Wireless and/or its affiliates aggregate liability arising under or in connection with the Sierra Wireless product, regardless of the number of events, occurrences, or claims giving rise to liability, be in excess of the price paid by the purchaser for the Sierra Wireless product.

Patents

This product may contain technology developed by or for Sierra Wireless Inc.

This product is manufactured or sold by Sierra Wireless Inc. or its affiliates under one or more patents licensed from MMP Portfolio Licensing.

Copyright

© 2021 Sierra Wireless. All rights reserved.

Trademarks

Sierra Wireless®, AirPrime®, AirLink®, AirVantage®, WISMO®, ALEOS® and the Sierra Wireless and Open AT logos are registered trademarks of Sierra Wireless, Inc. or one of its subsidiaries.

Watcher® is a registered trademark of NETGEAR, Inc., used under license.

Windows® and Windows Vista® are registered trademarks of Microsoft Corporation.

Macintosh® and Mac OS X® are registered trademarks of Apple Inc., registered in the U.S. and other countries.

QUALCOMM® is a registered trademark of QUALCOMM Incorporated. Used under license.

Other trademarks are the property of their respective owners.

Contact Information

Sales information and technical support, including warranty and returns	Web: sierrawireless.com/company/contact-us/ Global toll-free number: 1-877-687-7795 6:00 am to 5:00 pm PST
Corporate and product information	Web: sierrawireless.com

Document History

Version	Date	Updates
1.0	November 01, 2017	Creation
2.0	May 28, 2021	Added new note under Introduction



Contents

1. INTRODUCTION	10
1.1. Common Flexible Form Factor (CF ³)	10
1.2. Physical Dimensions	11
1.3. General Features.....	11
1.4. Architecture.....	13
1.5. Interfaces	13
1.6. Connection Interface	14
1.7. ESD	15
1.8. Environmental and Certifications.....	15
1.8.1. Environmental Specifications.....	15
1.8.2. Regulatory.....	16
1.8.3. RoHS Directive Compliant	16
1.8.4. Disposing of the Product.....	16
1.9. References	16
2. PAD DEFINITION	17
2.1. Pad Types.....	21
2.2. Pad Configuration (Top View, Through Module)	22
3. DETAILED INTERFACE SPECIFICATIONS	23
3.1. Power Supply.....	23
3.2. Current Consumption	24
3.3. VGPIO	25
3.4. USIM Interface.....	25
3.4.1. UIM1_DET	26
3.5. USB Interface	26
3.6. Electrical Information for Digital I/O	27
3.7. General Purpose Input/Output (GPIO)	28
3.8. Main Serial Link (UART1).....	28
3.9. Power On Signal (PWR_ON_N).....	29
3.10. Reset Signal (RESET_IN_N).....	30
3.11. Analog to Digital Converter (ADC)	31
3.12. Clock Interface.....	32
3.13. Debug Interface	32
3.14. JTAG Interface	32
3.15. Wake Up Signal (WAKE-UP).....	33
3.16. Fast Shutdown Signal (FAST_SHUTDOWN).....	34
3.17. PWM	34

3.18.	RF Interface	35
3.18.1.	RF Connection	35
3.18.2.	RF Performances	35
4.	MECHANICAL DRAWINGS	37
5.	DESIGN GUIDELINES	39
5.1.	Power-Up Sequence	39
5.2.	Module Switch-Off	39
5.3.	Sleep Mode Management	39
5.4.	Power Supply Design	40
5.5.	Power On Connection Examples	40
5.6.	USIM1 Application	41
5.7.	EMC and ESD Guidelines for USIM1 Card	41
5.8.	ESD Guidelines for USB.....	42
5.9.	PWM	42
6.	RELIABILITY SPECIFICATION (TBC)	44
6.1.	Reliability Compliance	44
6.2.	Reliability Prediction Model	44
6.2.1.	Life Stress Test	44
6.2.2.	Environmental Resistance Stress Tests	45
6.2.3.	Corrosive Resistance Stress Tests.....	45
6.2.4.	Thermal Resistance Cycle Stress Tests.....	46
6.2.5.	Mechanical Resistance Stress Tests.....	47
6.2.6.	Handling Resistance Stress Tests.....	48
7.	FCC LEGAL INFORMATION	49
8.	ORDERING INFORMATION	51
9.	TERMS AND ABBREVIATIONS	52



List of Figures

Figure 1.	Architecture Overview	13
Figure 2.	Mechanical Overview (Top View and Bottom View)	14
Figure 3.	Actual Module (Top View)	14
Figure 4.	Actual Module (Bottom View)	14
Figure 5.	Pad Configuration.....	22
Figure 6.	PWR_ON_N and PWR_OFF Sequence	30
Figure 7.	JTAG Timing Waveform	33
Figure 8.	Relative Timing for the PWM Output.....	34
Figure 9.	Mechanical Drawing	37
Figure 10.	Dimensions and Footprint Drawing	38
Figure 11.	Voltage Limiter Example	40
Figure 12.	PWR_ON_N Connection Example with Switch.....	40
Figure 13.	PWR_ON_N Connection Example with an Open Collector Transistor	40
Figure 14.	Design Application with USIM1 Slot.....	41
Figure 15.	EMC and ESD Components Close to the USIM1.	41
Figure 16.	ESD Protection for USB	42
Figure 17.	Example of an LED Driven by the PWM0 Output	42
Figure 18.	Example of a BUZZER Driven by the PWM0 Output.....	43



List of Tables

Table 1.	Supported Bands/Connectivity	10
Table 2.	General Features	11
Table 3.	ESD Specifications.....	15
Table 4.	Environmental Specifications	15
Table 5.	Pin Definition	17
Table 6.	Pad Type Codes.....	21
Table 7.	Power Supply Pad Description.....	23
Table 8.	Power Supply Electrical Characteristics.....	23
Table 9.	Low Current Consumption Mode.....	24
Table 10.	Current Consumption (Nominal Voltage at 3.7V; Ambient Temperature at +25°C)	24
Table 11.	VGPIIO Pad Description.....	25
Table 12.	VGPIIO Electrical Characteristics.....	25
Table 13.	USIM1 Pad Description	26
Table 14.	USIM1 Electrical Characteristics	26
Table 15.	USB Pad Description.....	26
Table 16.	USB Electrical Characteristics.....	27
Table 17.	Digital I/O Electrical Characteristics	27
Table 18.	GPIO Pad Description	28
Table 19.	UART1 Pad Description	28
Table 20.	PWR_ON_N Pad Description.....	29
Table 21.	PWR_ON_N Electrical Characteristics	29
Table 22.	RESET_IN_N Pad Description.....	30
Table 23.	RESET_IN_N Electrical Characteristics.....	31
Table 24.	ADC Pad Description	31
Table 25.	ADC Electrical Characteristics	31
Table 26.	Clock Interface Pad Description	32
Table 27.	Software Trace Pad Description.....	32
Table 28.	JTAG Pad Description	32
Table 29.	JTAG Electrical Characteristics.....	33
Table 30.	WAKE-UP Pad Description	33
Table 31.	WAKE-UP Electrical Characteristics	34
Table 32.	FAST_SHUTDOWN Pad Description	34
Table 33.	FAST_SHUTDOWN Electrical Characteristics	34
Table 34.	PWM Pad Description	35
Table 35.	PWM Electrical Characteristics (TBC)	35
Table 36.	RF Pad Connection	35
Table 37.	Typical RX Sensitivity.....	36

Table 38.	Standards Conformity.....	44
Table 39.	Life Stress Test.....	44
Table 40.	Environmental Resistance Stress Tests	45
Table 41.	Corrosive Resistance Stress Tests	45
Table 42.	Thermal Resistance Cycle Stress Tests	46
Table 43.	Mechanical Resistance Stress Tests	47
Table 44.	Handling Resistance Stress Tests	48
Table 45.	Ordering Information	51



1. Introduction

This document is the Product Technical Specification for the AirPrime HL77xx series of embedded modules. It defines the high-level product features and illustrates the interfaces for these features; and is intended to cover the hardware aspects of the product, including electrical and mechanical.

Variants covered in this document are:

- HL7718
- HL7748
- HL7749

Note: Sierra Wireless modules are shipped factory-programmed, with industry or mobile operator approved firmware, according to the specific SKU ordered. Periodically, newer firmware versions become available and can include new features, bug fixes, or critical security updates. Sierra Wireless strongly recommends that customers establish their own production capability for updating module firmware on their assembled end platform, in the event that a newer firmware must be installed before deployment. Sierra Wireless also recommends customers design their products to support post-deployment FOTA upgrades using the AirVantage cloud platform.

The AirPrime HL77xx modules belong to the AirPrime HL Series from Essential Connectivity Module family. These are industrial grade Embedded Wireless Modules that provides data connectivity on LTE networks (as listed in Table 1 Supported Bands/Connectivity).

The AirPrime HL77xx modules support a large variety of interfaces such as USB 2.0, UART, ADC, USIM interface, PWM and GPIOs to provide customers with the highest level of flexibility in implementing high-end solutions.

Table 1. Supported Bands/Connectivity

RF Band	Transmit Band (Tx)	Receive Band (Rx)	Maximum Output Power	HL7718	HL7748	HL7749
LTE B2	1850 to 1910 MHz	1930 to 1990 MHz	23dBm ± 2dBm		✓	
LTE B3	1710 to 1785 MHz	1805 to 1880 MHz	23dBm ± 2dBm			✓
LTE B4	1710 to 1755 MHz	2110 to 2155 MHz	23dBm ± 2dBm		✓	
LTE B12	699 to 716 MHz	729 to 746 MHz	23dBm ± 2dBm		✓	
LTE B13	777 to 787 MHz	746 to 756 MHz	23dBm ± 2dBm	✓		
LTE B28	703 to 748 MHz	758 to 803 MHz	23dBm ± 2dBm			✓

1.1. Common Flexible Form Factor (CF³)

The AirPrime HL77xx modules belong to the Common Flexible Form Factor (CF³) family of modules. This family consists of a series of WWAN modules that share the same mechanical dimensions (same width and length with varying thicknesses) and footprint. The CF³ form factor provides a unique solution to a series of problems faced commonly in the WWAN module space as it:

- Accommodates multiple radio technologies (LTE advanced) and band groupings.
- Supports bit-pipe (Essential Module Series) and value add (Smart Module Series) solutions.
- Offers electrical and functional compatibility.
- Provides Direct Mount as well as Socketability depending on customer needs.

1.2. Physical Dimensions

AirPrime HL77xx modules are compact, robust, fully shielded modules with the following dimensions:

- Length: 23 mm
- Width: 22 mm
- Thickness: 2.5 mm
- Weight: 2.6 g

Note: Dimensions specified above are typical values.

1.3. General Features

The table below summarizes the AirPrime HL77xx modules' features.

Table 2. General Features

Feature	Description
Physical	<ul style="list-style-type: none"> • Small form factor (146-pad solderable LGA pad) – 23mm x 22mm x 2.5mm (nominal) • Metal shield can. • RF connection pads (RF main interface) • Baseband signals connection
Electrical	Single or double supply voltage (VBATT and VBATT_PA) – 3.2V – 4.5V
RF	HL7718 (Mono-band LTE): <ul style="list-style-type: none"> • LTE B13 HL7748 (Tri-band LTE): <ul style="list-style-type: none"> • LTE B2 • LTE B4 • LTE B12 HL7749 (Dual-band LTE): <ul style="list-style-type: none"> • LTE B3 • LTE B28
SIM interface	<ul style="list-style-type: none"> • Only 1.8V support for USIM1 • SIM extraction / hot plug detection • SIM/USIM support • Conforms with ETSI UICC Specifications. • Supports SIM application tool kit with proactive SIM commands
Application interface	<ul style="list-style-type: none"> • NDIS NIC interface support (Windows 7, Windows 8, Linux) • MBIM support • Multiple non-multiplexed USB channel support • Dial-up networking • USB selective suspend to maximize power savings • CMUX multiplexing over UART • AT command interface – 3GPP 27.007 standard, plus proprietary extended AT commands

Feature	Description
Protocol stack	Single mode LTE operation: <ul style="list-style-type: none"> • LTE FDD, bandwidth 1.4-20 MHz • System Release: 3GPP Rel. 13 • Category M1 (up to 375 kbit/s in uplink, 300 kbit/s in downlink) • Max modulation 16 QAM UL/DL • Intra-frequency and inter-frequency mobility
SMS	<ul style="list-style-type: none"> • SMS over SGs • SMS MO and MT • SMS saving to SIM card or ME storage • SMS reading from SIM card or ME storage • SMS sorting • SMS concatenation • SMS Status Report • SMS replacement support • SMS storing rules (support of AT+CNMI, AT+CNMA)
Connectivity	<ul style="list-style-type: none"> • Multiple cellular packet data profiles • Sleep mode for minimum idle power draw • Mobile-originated PDP context activation / deactivation • Static and Dynamic IP address. The network may assign a fixed IP address or dynamically assign one using DHCP (Dynamic Host Configuration Protocol). • PDP context type (IPv4, IPv6, IPv4v6). IP Packet Data Protocol context • RFC1144 TCP/IP header compression
Environmental	Operating temperature ranges (industrial grade): <ul style="list-style-type: none"> • Class A: -30°C to +70°C • Class B: -40°C to +85°C
RTC	Real Time Clock (RTC)

1.4. Architecture

The figure below presents an overview of the AirPrime HL77xx modules' internal architecture and external interfaces.

Note: Dotted parts are optional depending on variant.

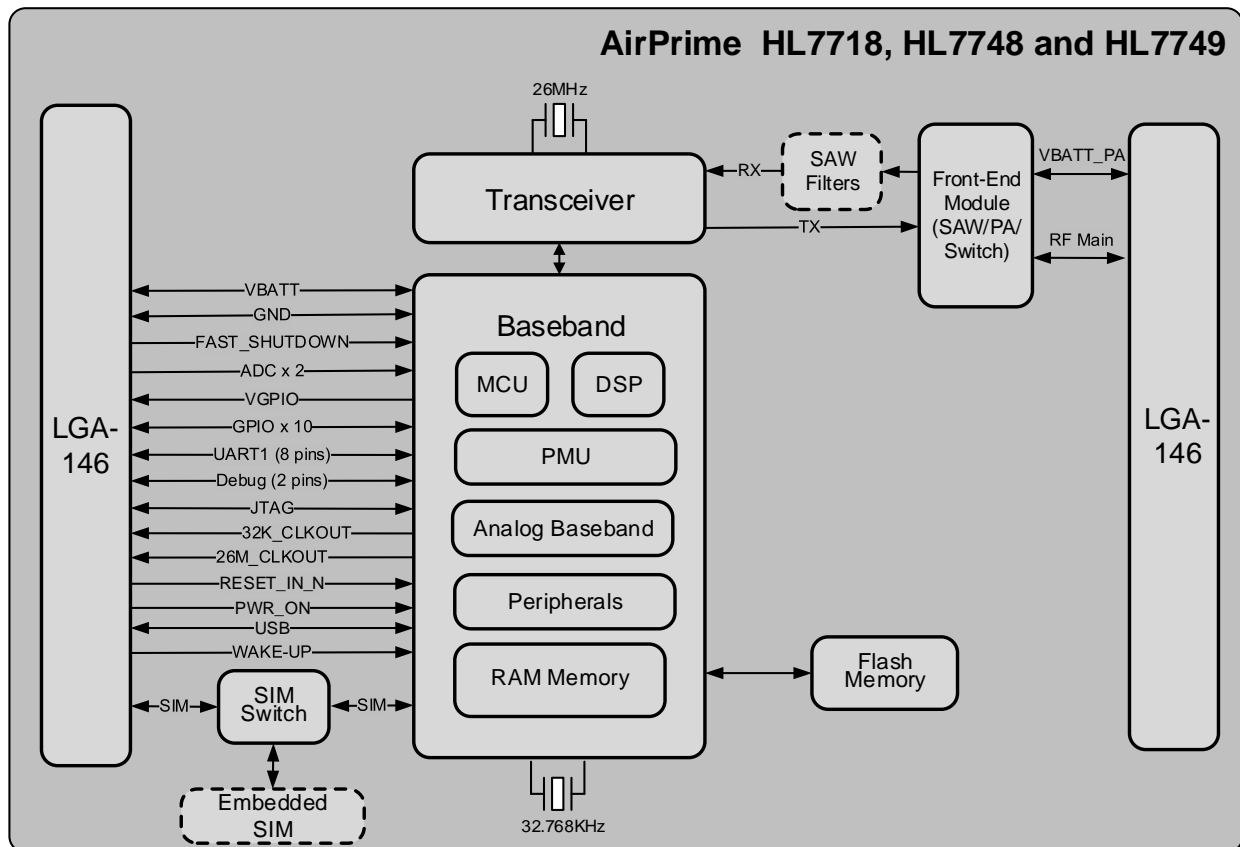

Figure 1. Architecture Overview

1.5. Interfaces

The AirPrime HL77xx modules provide the following interfaces and peripheral connectivity:

- 1x - VGPIO (1.8V)
- 1x - 1.8V USIM
- 1x - eUICC/USIM (optional embedded SIM)
- 1x - USB 2.0
- 10x - GPIOs (1 of which has a multiplex)
- 1x - 8-wire UART
- 1x - Active Low POWER ON
- 1x - Active Low RESET
- 2x - ADC
- 2x - System Clock Out (32,768KHz and 26MHz)
- 1x - Debug Interface

- 1x - JTAG Interface
- 1x - Wake up signal
- 1x - Fast shutdown signal
- 1x - PWM
- 1x - Main RF Antenna

1.6. Connection Interface

The AirPrime HL77xx modules are an LGA form factor device. All electrical and mechanical connections are made through the 146 Land Grid Array (LGA) pads on the bottom side of the PCB.

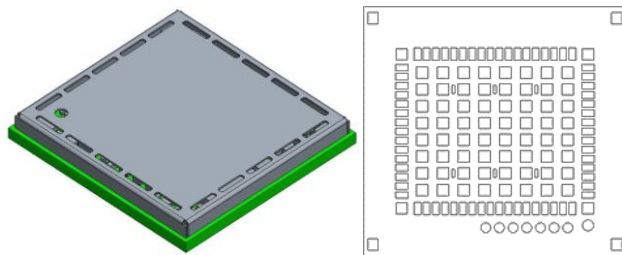

Figure 2. Mechanical Overview (Top View and Bottom View)

The 146 pads have the following distribution:

- 66 inner signal pads, 1x0.5mm, pitch 0.8mm
- 1 reserved test point (do not connect), 1.0mm diameter
- 7 test point (JTAG), 0.8mm diameter, 1.20mm pitch
- 64 inner ground pads, 1.0x1.0mm, pitch 1.825mm/1.475mm
- 4 inner corner ground pads, 1x1mm
- 4 outer corner ground pads, 1x0.9mm

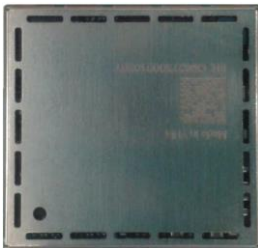

Figure 3. Actual Module (Top View)

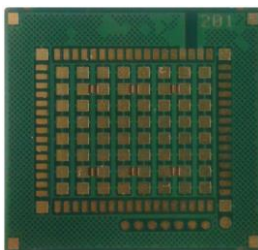

Figure 4. Actual Module (Bottom View)

1.7. ESD

Refer to the following table for ESD Specifications.

Table 3. ESD Specifications

Category	Connection	Specification
Operational	RF ports	IEC-61000-4-2 — Level (Electrostatic Discharge Immunity Test)
Non-operational	Host connector interface	Unless otherwise specified: <ul style="list-style-type: none"> • JESD22-A114 \pm 1kV Human Body Model (TBC) • JESD22-A115 \pm 200V Machine Model (TBC) • JESD22-C101C \pm 250V Charged Device Model (TBC)
Signals	SIM connector	Adding ESD protection is highly recommended at the point where the USIM contacts are exposed, and for any other signals that would be subjected to ESD by the user.
	Other host signals	

1.8. Environmental and Certifications

1.8.1. Environmental Specifications

The environmental specification for both operating and storage conditions are defined in the table below.

Table 4. Environmental Specifications

Conditions	Range
Operating Class A	-30°C to +70°C
Operating Class B	-40°C to +85°C
Storage	-40°C to +85°C

Class A is defined as the operating temperature ranges that the device:

- Shall exhibit normal function during and after environmental exposure.
- Shall meet the minimum requirements of 3GPP or appropriate wireless standards.

Class B is defined as the operating temperature ranges that the device:

- Shall remain fully functional during and after environmental exposure
- Shall exhibit the ability to establish an SMS or DATA call (emergency call) at all times even when one or more environmental constraint exceeds the specified tolerance.
- Unless otherwise stated, full performance should return to normal after the excessive constraint(s) have been removed.

1.8.2. Regulatory

The AirPrime HL7718 and HL7748 modules will be compliant with FCC regulations, while the AirPrime HL7749 module will be compliant with RCM regulations.

1.8.3. RoHS Directive Compliant

The AirPrime HL77xx modules are compliant with RoHS Directive 2011/65/EU which sets limits for the use of certain restricted hazardous substances. This directive states that “from 1st July 2006, new electrical and electronic equipment put on the market does not contain lead, mercury, cadmium, hexavalent chromium, polybrominated biphenyls (PBB) or polybrominated diphenyl ethers (PBDE)”.

1.8.4. Disposing of the Product

This electronic product is subject to the EU Directive 2012/19/EU for Waste Electrical and Electronic Equipment (WEEE). As such, this product must not be disposed of at a municipal waste collection point. Please refer to local regulations for directions on how to dispose of this product in an environmental friendly manner.



1.9. References

- [1] AirPrime HL Series Customer Process Guidelines
Reference Number: 4114330
- [2] AirPrime HL77xx AT Commands Interface Guide
Reference Number: 41110842
- [3] AirPrime HL Series Development Kit User Guide
Reference Number: 4114877



2. Pad Definition

AirPrime HL77xx pads are divided into 2 functional categories.

- Core functions and associated pads cover all the mandatory features for M2M connectivity and will be available by default across all CF³ family of modules. These Core functions are always available and always at the same physical pad locations. A customer platform using only these functions and associated pads are guaranteed to be forward and/or backward compatible with the next generation of CF³ modules.
- Extension functions and associated pads bring additional capabilities to the customer. Whenever an Extension function is available on a module, it is always at the same pad location.

Other pads marked as “not connected” or “reserved” should not be used.

Table 5. Pin Definition

Pad #	Signal Name	Function	I/O	Active Low/High	Power Supply Domain	Recommendation for Unused Pads	Type
1	GPIO1	General purpose input/output	I/O	-	1.8V	Left Open	Extension
2	UART1_RI	UART1 Ring indicator	O	-	1.8V	Connect to test point	Core
3	UART1_RTS	UART1 Request to send	I	L	1.8V	Connect to test point	Core
4	UART1_CTS	UART1 Clear to send	O	L	1.8V	Connect to test point	Core
5	UART1_TX	UART1 Transmit data	I	-	1.8V	Connect to test point	Core
6	UART1_RX	UART1 Receive data	O	-	1.8V	Connect to test point	Core
7	UART1_DTR	UART1 Data terminal ready	I	L	1.8V	Connect to test point	Core
8	UART1_DCD	UART1 Data carrier detect	O	L	1.8V	Connect to test point	Core
9	UART1_DSR	UART1 Data set ready	O	L	1.8V	Connect to test point	Core
10	GPIO2	General purpose input/output	I/O	-	1.8V	Connect to test point	Core
11	RESET_IN_N	Input reset signal	I	L	1.8V	Left Open	Core

Pad #	Signal Name	Function	I/O	Active Low/High	Power Supply Domain	Recommendation for Unused Pads	Type
12	USB_D-	USB Data Negative (Low / Full Speed)	I/O	-	3.3V	Connect to test point	Extension
		USB Data Negative (High Speed)			0.38V		
13	USB_D+	USB Data Positive (Low / Full Speed)	I/O	-	3.3V	Connect to test point	Extension
		USB Data Positive (High Speed)			0.38V		
14	NC	Not Connected					Not connected
15	NC	Not Connected					Not connected
16	NC	Not Connected					Not connected
17	NC	Not Connected (Reserved for future use)					Not connected
18	NC	Not Connected (Reserved for future use)					Not connected
19	WAKE-UP	Wake Up	I	H	1.8V	Left Open	Extension
20	NC	Not Connected (Reserved for future use)					Not connected
21	NC	Not Connected					Not connected
22	GNSS_FREQ_OUT	26MHz System Clock Output	O	-	1.8V	Left Open	Extension
23	32K_CLKOUT	32.768kHz System Clock Output	O	-	1.8V	Left Open	Extension
24	ADC1	Analog to digital converter	I	-	1.2V	Left Open	Extension
25	ADC0	Analog to digital converter	I	-	1.2V	Left Open	Extension
26	UIM1_VCC	1.8V USIM1 Power supply	O	-	1.8V	Mandatory connection	Core
27	UIM1_CLK	1.8V USIM1 Clock	O	-	1.8V	Mandatory connection	Core
28	UIM1_DATA	1.8V USIM1 Data	I/O	-	1.8V	Mandatory connection	Core
29	UIM1_RESET	1.8V USIM1 Reset	O	L	1.8V	Mandatory connection	Core
30	GND	Ground	0V		0V	Mandatory connection	Extension
31	NC	Not Connected					Not connected
32	GND	Ground	0V		0V	Mandatory connection	Extension
33	PCM_OUT*	PCM data out	O	-	1.8V	Left Open	Extension
34	PCM_IN*	PCM data in	I	-	1.8V	Left Open	Extension
35	PCM_SYNC*	PCM sync out	I/O	-	1.8V	Left Open	Extension

Pad #	Signal Name	Function	I/O	Active Low/High	Power Supply Domain	Recommendation for Unused Pads	Type
36	PCM_CLK*	PCM clock	I/O	-	1.8V	Left Open	Extension
37	GND	Ground	0V		0V	Mandatory connection	Core
38	NC	Not Connected (Reserved for future use)					Not connected
39	GND	Ground	0V		0V	Mandatory connection	Core
40	GPIO7	General purpose input/output	I/O	-	1.8V	Left Open	Core
41	GPIO8	General purpose input/output	I/O	-	1.8V	Connect to test point	Core
42	NC	Not Connected (Reserved for future use)					Not connected
43	NC	Not Connected (Reserved for future use)					Not connected
44	DEBUG_TX	Debug Transmit data	O		1.8V	Left Open	Extension
45	VGPIO	GPIO voltage output	O		1.8V	Left Open	Core
46	GPIO6	General purpose input/output	I/O	-	1.8V	Left Open	Core
47	NC	Not Connected (Reserved for future use)				Left Open	Not connected
48	GND	Ground	0V		0V	Mandatory connection	Core
49	RF_MAIN	RF Input/output		-		Mandatory connection	Core
50	GND	Ground	0V		0V	Mandatory connection	Core
51	DEBUG_RX	Debug Receive data	I		1.8V	Left Open	Extension
52	GPIO10	General purpose input/output	I/O	-	1.8V	Left Open	Extension
53	GPIO11	General purpose input/output	I/O	-	1.8V	Left Open	Extension
54	GPIO15	General purpose input/output	I/O	-	1.8V	Left Open	Extension
55	NC	Not Connected					Not connected
56	NC	Not Connected					Not connected
57	NC	Not Connected					Not connected
58	PWM0	Pulse Width Modulation	O	-	1.8V/3V	Left Open	Extension
59	PWR_ON_N	Active Low Power On control signal	I	L	1.8V	Mandatory connection	Core
60	NC	Not Connected					Not connected

Pad #	Signal Name	Function	I/O	Active Low/High	Power Supply Domain	Recommendation for Unused Pads	Type
61	VBATT_PA	Power supply (refer to section 3.1 Power Supply for more information)	I	-	3.2V (min) 3.7V (typ) 4.5V (max)	Mandatory connection	Core
62	VBATT_PA	Power supply (refer to section 3.1 Power Supply for more information)	I	-	3.2V (min) 3.7V (typ) 4.5V (max)	Mandatory connection	Core
63	VBATT	Power supply	I	-	3.2V (min) 3.7V (typ) 4.5V (max)	Mandatory connection	Core
64	UIM1_DET / GPIO3	USIM1 Detection / General purpose input/output	I/O	H	1.8V	Left Open	Core
65	FAST_SHUTDOWN	Fast Shutdown	I	L	1.8V	Left Open	Extension
66	GPIO5	General purpose input/output	I/O	-	1.8V	Left Open	Extension
67-70	GND	Ground	GND		0V		Core
71 - 166	<i>Note: These pads are not available on the AirPrime HL77xx modules.</i>						
167 - 234	GND	Ground	GND		0V		Core
236	JTAG_RESET	JTAG RESET	I	L	1.8V	Left Open	Extension
237	JTAG_TCK	JTAG Test Clock	I	-	1.8V	Left Open	Extension
238	JTAG_TDO	JTAG Test Data Output	O	-	1.8V	Left Open	Extension
239	JTAG_TMS	JTAG Test Mode Select	I	-	1.8V	Left Open	Extension
240	JTAG_TRST	JTAG Test Reset	I	L	1.8V	Left Open	Extension
241	JTAG_TDI	JTAG Test Data Input	I	-	1.8V	Left Open	Extension
242	NC	Not Connected					Not connected

* This pad is not supported on the AirPrime HL77xx.

2.1. Pad Types

Table 6. Pad Type Codes

Type	Definition
I	Digital Input
O	Digital Output
I/O	Digital Input / Output
L	Active High
H	Active Low
T	Tristate
T/PU	Tristate with pull-up enabled
T/PD	Tristate with pull-down enabled
PU	Pull-up enabled
PD	Pull-down enabled
N/A	Not Applicable

2.2. Pad Configuration (Top View, Through Module)

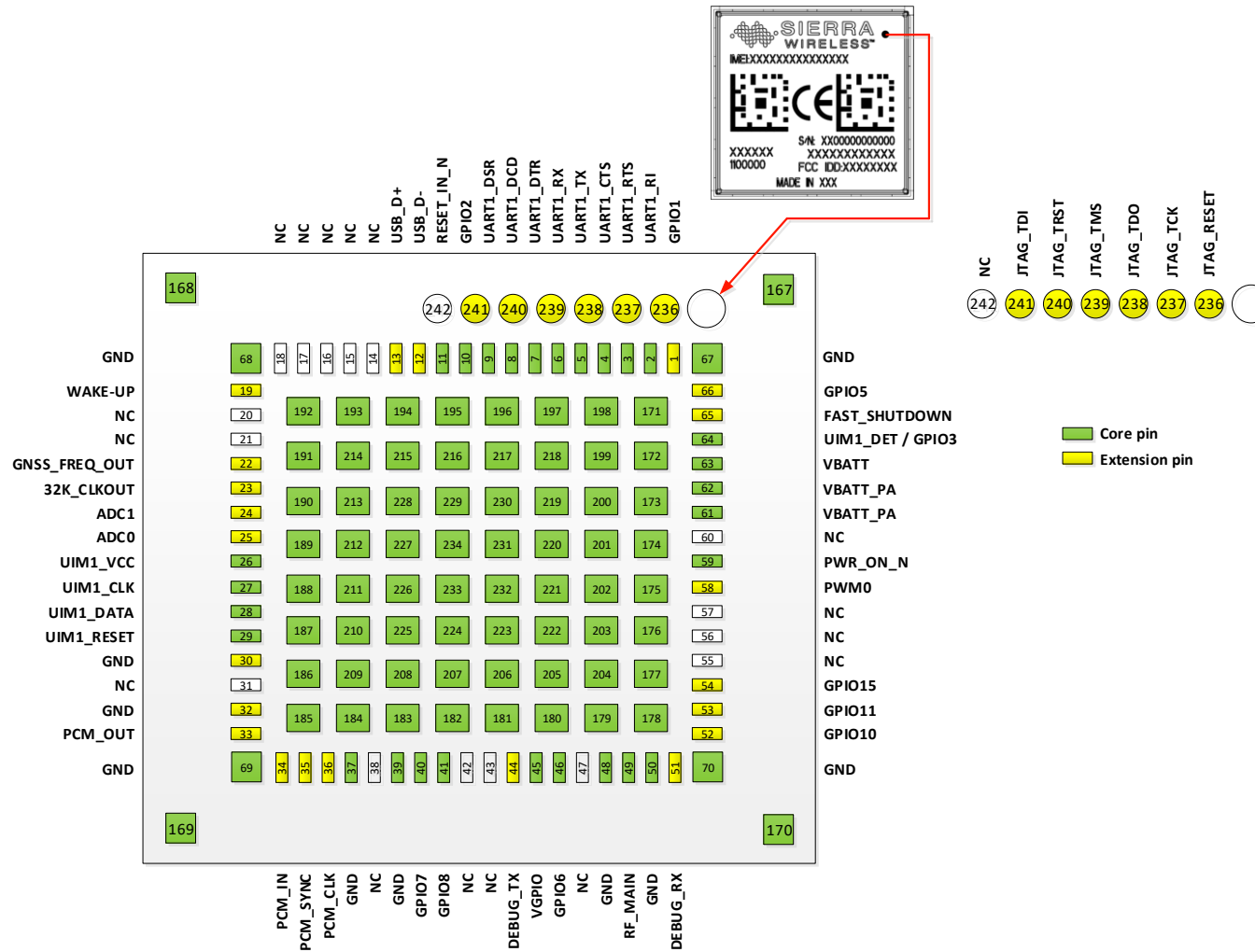

Figure 5. Pad Configuration



3. Detailed Interface Specifications

Note: If not specified, all electrical values are given for VBATT=3.7V and an operating temperature of 25°C.

For standard applications, VBATT and VBATT_PA must be tied externally to the same power supply. For some specific applications, AirPrime HL77xx modules support separate VBATT and VBATT_PA connections if requirements below are fulfilled.

3.1. Power Supply

The AirPrime HL77xx modules are supplied through the VBATT and VBATT_PA signals.

Refer to the following table for the pad description of the Power Supply interface.

Table 7. Power Supply Pad Description

Pad Number	Signal Name	I/O	Description
63	VBATT	I	Power supply (base band)
61, 62	VBATT_PA	I	Power supply (radio frequency)
37, 39, 48, 67-70, 167-234	GND		Ground

Refer to the following table for the electrical characteristics of the Power Supply interface.

Table 8. Power Supply Electrical Characteristics

Supply	Minimum	Typical	Maximum
VBATT voltage (V)	3.2 ¹	3.7	4.5
VBATT_PA voltage (V) Full Specification	3.2 ¹	3.7	4.5
VBATT_PA voltage (V) Extended Range	2.8 ² (TBC)	3.7	4.5

1 This value must be guaranteed during the burst

2 No guarantee of 3GPP performances over extended range

Note: Load capacitance for VBATT is around 37µF ± 20% (TBC) embedded inside the module.
Load capacitance for VBATT_PA is around 11µF ± 20% (TBC) embedded inside the module.

3.2. Current Consumption

The following table lists the current consumption of the AirPrime HL77xx modules at different conditions.

Note: Typical values are defined for VBATT/VBATT_PA at 3.7V and 25°C, for 50Ω impedance at all RF ports with VSWR1:1 and CMW500. Maximum values are defined with worst conditions among supported ranges of voltages and temperature (50Ω, VSWR1:1 and CMW500).

Table 9. Low Current Consumption Mode

Parameter	Typical	Maximum	Unit
Off mode	15	TBD	μA
Sleep mode (deregistered from the network)	1.3	TBD	mA
PSM mode	100 (TBC)	TBD	μA

Table 10. Current Consumption

Parameter	Band	Frequency	Typical	Unit
LTE in communication mode (TX Max) Pout=23dBm BW=10Mhz RMC mode 4RB_DL & 6RB_UL	B3	1810 MHz	290	mA
		1843 MHz	285	mA
		1875 MHz	285	mA
LTE in communication mode (TX Max) Pout=23dBm BW=10Mhz RMC mode 4RB_DL & 6RB_UL	B28	763 MHz	275	mA
		781 MHz	268	mA
		798 MHz	260	mA
LTE in communication mode (TX Max) Pout=23dBm BW=10Mhz RMC mode 4RB_DL & 6RB_UL	B12	734 MHz	265	mA
		738 MHz	260	mA
		741 MHz	260	mA
LTE in communication mode (TX Max) Pout=23dBm BW=10Mhz RMC mode 4RB_DL & 6RB_UL	B2	1935 MHz	290	mA
		1960 MHz	292	mA
		1985 MHz	303	mA
LTE in communication mode (TX Max) Pout=23dBm BW=10Mhz RMC mode 4RB_DL & 6RB_UL	B4	2115 MHz	280	mA
		2133 MHz	284	mA
		2150 MHz	280	mA
LTE in communication mode (TX Max) Pout=23dBm BW=10Mhz RMC mode 4RB_DL & 6RB_UL	B13	751 MHz	250	mA

3.3. VGPIO

The VGPIO output can be used to:

- Pull-up signals such as I/Os
- Supply the digital transistors driving LEDs

The VGPIO output is available when the AirPrime HL77xx module is switched ON.

Refer to the following table for the pad description of the VGPIO interface.

Table 11. VGPIO Pad Description

Pad Number	Signal Name	I/O	Description
45	VGPIO	O	GPIO voltage output

Refer to the following table for the electrical characteristics of the VGPIO interface.

Table 12. VGPIO Electrical Characteristics

Parameter	Minimum	Typical	Maximum	Remarks
Voltage level (V)	1.7	1.8	1.9	Both active mode and sleep mode
Current capability Active Mode (mA)	-	-	TBD	Power management support up to (TBD) mA output in Active mode
Current capability Sleep Mode (mA)	-	-	TBD	Power management support up to (TBD) mA output in Sleep mode
Rise Time (ms)	-	-	TBD	Start-Up time from 0V

3.4. USIM Interface

The AirPrime HL77xx modules have one physical USIM interface, USIM1, and an optional internal USIM or eUICC.

The USIM1 interface allows control of a 1.8V USIM and is fully compliant with GSM 11.11 recommendations concerning USIM functions.

The five signals used by the UIM1 are as follows:

- UIM1_VCC: Power supply
- UIM1_CLK: Clock
- UIM1_DATA: I/O port
- UIM1_RESET: Reset
- UIM1_DET/GPIO3: Hardware SIM detection

Refer to the following table for the pad description of the USIM1 interface.

Table 13. USIM1 Pad Description

Pad Number	Signal Name	Description	Multiplex
26	UIM1_VCC	1.8V USIM1 Power supply	
27	UIM1_CLK	1.8V USIM1 Clock	
28	UIM1_DATA	1.8V USIM1 Data	
29	UIM1_RESET	1.8V USIM1 Reset	
64	UIM1_DET / GPIO3	1.8V USIM1 Detection	GPIO3

Refer to the following table for the electrical characteristics of the USIM1 interface.

Table 14. USIM1 Electrical Characteristics

Parameter	Minimum	Typical	Maximum	Remarks
UIM1 Interface Voltage (V) (VCC, CLK, IO, RESET)	-	1.80	-	The appropriate output voltage is auto detected and selected by software.
UIM1 Detect	-	1.80	-	High active
UIM1_VCC Current (mA)	-	-	10 (TBC)	

Refer to section 5.6 USIM1 Application for a USIM application example.

3.4.1. UIM1_DET

UIM1_DET is used to detect and notify the application about the insertion and removal of a USIM device in the USIM socket connected to the main USIM interface (UIM1). When a USIM is inserted, the state of UIM1_DET transitions from logic 0 to logic 1. Inversely, when a USIM is removed, the state of UIM1_DET transitions from logic 1 to logic 0.

Enabling or disabling this USIM detect feature can be done using an AT command. Refer to document [2] AirPrime HL77xx AT Commands Interface Guide for more information.

3.5. USB Interface

The AirPrime HL77xx modules have one Universal Serial Bus interface compliant with USB Rev 2.0 (self-powered).

Refer to the following table for the pad description of the USB interface.

Table 15. USB Pad Description

Pad Number	Signal Name	I/O	Function
12	USB_D-	I/O	USB Data Negative
13	USB_D+	I/O	USB Data Positive

Refer to the following table for the electrical characteristics of the USB interface.

Table 16. USB Electrical Characteristics

Parameter	Minimum	Typical	Maximum	Units
Input voltage at pins USB_D+ / USB_D-	3.15	3.3	3.45	V

3.6. Electrical Information for Digital I/O

The table below enumerates the electrical characteristics of the following digital interfaces:

- UART
- PCM
- JTAG
- GPIOs
- RESET
- PWM
- WAKE_UP

Table 17. Digital I/O Electrical Characteristics

Parameter	Description	Minimum	Typical	Maximum	Units
V _{IH}	Logic High Input Voltage	0.85 x VDDIO*		VDDIO* + 0.3	V
V _{IL}	Logic Low Input Voltage	-0.3		0.25 x VDDIO*	V
I _{IH} / I _{IL}	Input Leakage Current (either Low or High, and No Pull enabled)		0.03		μA
V _{OH}	Logic High Output Voltage	VDDIO* – 0.45		VDDIO*	V
V _{OL}	Logic Low Output Voltage	0		0.8	V
I _{OH} / I _{OL}	Output Leakage Current (either Low or High) – assume no external load		0.03		μA
R _{PU}	Internal Pull Down Resistor	53	89	164	KΩ
R _{PD}	Internal Pull Up Resistor	54	96	189	KΩ
Input Capacitance	Input Pin Capacitance			7	pF

* VDDIO = VGPIO = 1.8V.

3.7. General Purpose Input/Output (GPIO)

The AirPrime HL77xx modules provide 10 GPIOs, 1 of which has a multiplex.

The following table describes the pin description of the GPIO interface.

Table 18. GPIO Pad Description

Pad Number	Signal Name	Multiplex	I/O	Power Supply Domain
1	GPIO1		I/O	1.8V
10	GPIO2		I/O	1.8V
40	GPIO7		I/O	1.8V
41	GPIO8		I/O	1.8V
46	GPIO6		I/O	1.8V
52	GPIO10		I/O	1.8V
53	GPIO11		I/O	1.8V
54	GPIO15		I/O	1.8V
64	GPIO3	UIM1_DET	I/O	1.8V
66	GPIO5		I/O	1.8V

3.8. Main Serial Link (UART1)

The main serial link (UART1) is used for communication between the AirPrime HL77xx modules and a PC or host processor. It consists of a flexible 8-wire serial interface that complies with RS-232 interface.

The main serial link (UART1) is an asynchronous serial interface.

The signals used by UART1 are as follows:

- TX data (UART1_TX)
- RX data (UART1_RX)
- Request To Send (UART1_RTS)
- Clear To Send (UART1_CTS)
- Data Terminal Ready (UART1_DTR)
- Data Set Ready (UART1_DSR)
- Data Carrier Detect (UART1_DCD)
- Ring Indicator (UART1_RI)

Note: Signal names are according to PC view.

Refer to the following table for the pad description of the main serial link (UART1) interface.

Table 19. UART1 Pad Description

Pad Number	Signal Name*	I/O*	Description
2	UART1_RI	O	Signal incoming calls (data only), SMS, etc.
3	UART1_RTS	I	Request to send

Pad Number	Signal Name*	I/O*	Description
4	UART1_CTS	O	The AirPrime HL77xx is ready to receive AT commands
5	UART1_TX	I	Transmit data
6	UART1_RX	O	Receive data
7	UART1_DTR	I (active low)	Prevents the AirPrime HL77xx from entering sleep mode, switches between data mode and command mode, and wakes the module up.
8	UART1_DCD	O	Signal data connection in progress
9	UART1_DSR	O	Signal UART interface is ON

* According to PC view.

Note: **UART1_CTS must be left floating or set to level "0" before starting the HL77xx module.**

3.9. Power On Signal (PWR_ON_N)

The PWR_ON_N signal is internally connected to the permanent 1.8V supply regulator inside the AirPrime HL77xx module via a pull-up resistor. Once VBATT is supplied to the module, this 1.8V supply regulator will be enabled and so the PWR_ON_N signal is by default at high level.

A low-level signal on PWR_ON_N must be provided to switch the AirPrime HL77xx module ON, and the signal must be kept at low level to keep the module ON.

Refer to the following table for the pad description of the PWR_ON_N interface.

Table 20. PWR_ON_N Pad Description

Pad Number	Signal Name	I/O	Description
59	PWR_ON_N	I	Power the AirPrime HL77xx On

Refer to the following table for the electrical characteristics of the PWR_ON_N interface.

Table 21. PWR_ON_N Electrical Characteristics

Parameter	Minimum	Typical	Maximum
Input Voltage-Low (V)		-	0.51 (TBC)
Input Voltage-High (V)	1.33 (TBC)	-	2.2 (TBC)
Power-up period (ms) from PWR_ON_N falling edge	Always set to GND	-	-
PWR_ON_N assertion time (ms)	25 (TBC)		

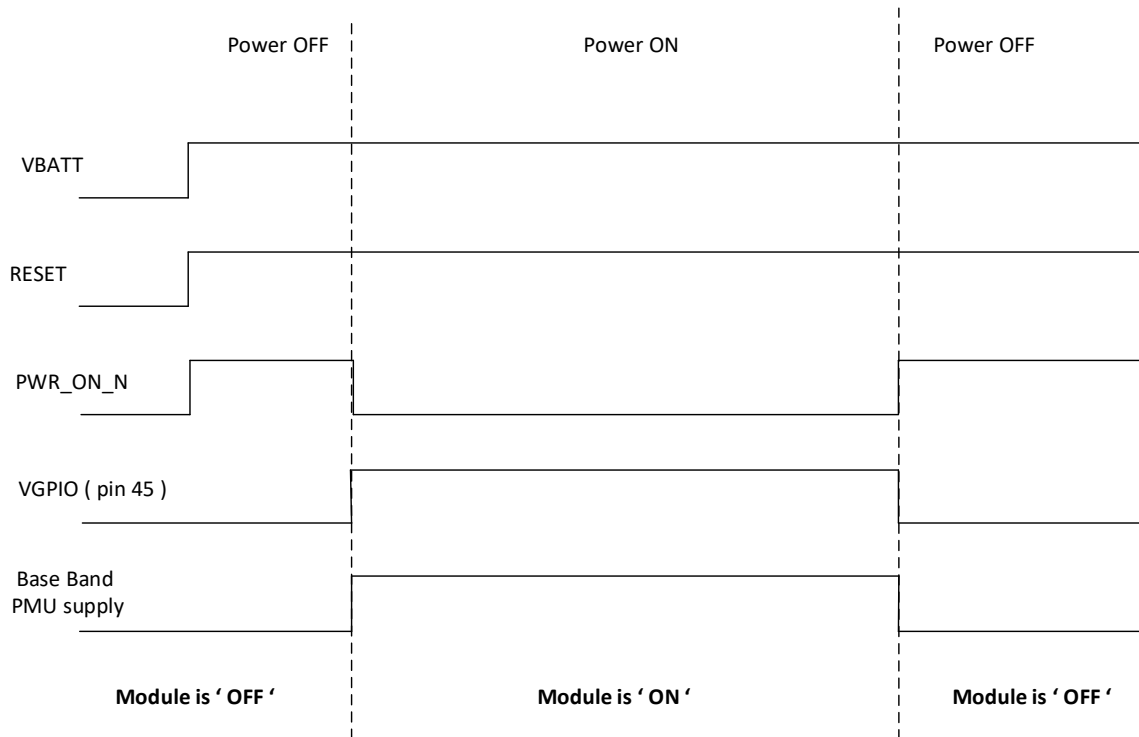

Figure 6. PWR_ON_N and PWR_OFF Sequence

Note: As PWR_ON_N is internally pulled up with 1MΩ, an open collector or open drain transistor must be used for ignition.

VGPIO is an output from the module that can be used to check if the module is active.

- When VGPIO = 0V, the module is OFF
- When VGPIO = 1.8V, the module is ON (it can be in idle, communication or sleep mode)

Note: To power the module off, use AT command **AT+CPOF** or **AT+CPWROFF**.

3.10. Reset Signal (RESET_IN_N)

To reset the module, a low-level pulse must be sent on the RESET_IN_N pad for 20ms (TBC). This action will immediately restart the AirPrime HL77xx module with the PWR_ON_N signal at low level. (If the PWR_ON_N signal is at high level, the module will be powered off.) As RESET_IN_N is internally pulled up, an open collector or open drain transistor should be used to control this signal.

Note: As RESET_IN_N is referenced to the VGPIO signal (1kΩ pull-up resistor to VGPIO 1.8V) an open collector or open drain transistor should be used to control this signal.

Refer to the following table for the pad description of the RESET_IN_N interface.

Table 22. RESET_IN_N Pad Description

Pad Number	Signal Name	I/O	Description
12	RESET_IN_N	I	Hardware reset the module

Refer to the following table for the electrical characteristics of the RESET_IN_N interface.

Table 23. RESET_IN_N Electrical Characteristics

Parameter	Minimum	Typical	Maximum
Input Voltage-Low (V)		-	0.51 (TBC)
Input Voltage-High (V)	1.33 (TBC)	-	2.2 (TBC)
Reset assertion time (ms)	20 (TBC)	-	-
Power-up period (ms) from RESET_IN_N falling edge*	2000 (TBC)	-	-

* With the PWR_ON_N signal at low level.

3.11. Analog to Digital Converter (ADC)

Two Analog to Digital Converter inputs, ADC0 and ADC1, are provided by AirPrime HL77xx modules. These converters are 8-bits resolution ADCs ranging from 0 to 1.8V.

Typical ADC use is for monitoring external voltage, wherein an application is used to safely power OFF an external supply in case of overvoltage.

Refer to the following table for the pad description of the ADC interface.

Table 24. ADC Pad Description

Pad Number	Signal Name	I/O	Description
24	ADC1	I	Analog to digital converter
25	ADC0	I	Analog to digital converter

Refer to the following table for the electrical characteristics of the ADC interface.

Table 25. ADC Electrical Characteristics

Parameter	Minimum	Typical	Maximum	Unit	Remarks
ADCx Resolution	-	8	-	bits	
Conversion Rate	-	-	2	MHz	
Input Voltage Range	0	-	1.8	V	General purpose input
Integral Nonlinearity	-	± 1	± 2	LSB	
Differential Nonlinearity	-	± 0.5	± 1	LSB	
Offset Error	-	± 1	± 2	LSB	%FS
Gain Error	-	± 1	± 2	LSB	%FS
Input Resistance	43	52	61	kΩ	
Input Capacitance during sampling phase	-	3		pF	

3.12. Clock Interface

The AirPrime HL77xx modules support two digital clock interfaces.

Enabling or disabling the clock out feature can be done using AT commands. For more information about AT commands, refer to document [2] AirPrime HL77xx AT Commands Interface Guide.

Refer to the following table for the pad description of the clock out interfaces.

Table 26. Clock Interface Pad Description

Pad Number	Signal Name	I/O	I/O Type	Description
22	GNSS_FREQ_OUT	O	1.8V	26MHz Digital Clock output
23	32K_CLKOUT	O	1.8V	32.768kHz Digital Clock output

3.13. Debug Interface

The AirPrime HL77xx modules provide a 2-wire debug port interface.

Table 27. Software Trace Pad Description

Pad Number	Signal Name*	I/O*	I/O Type	Description
44	DEBUG_TX	O	1.8V	Debug Transmit Data
51	DEBUG_RX	I	1.8V	Debug Receive Data

* According to module view.

Note: It is strongly recommended to provide access through Test Points to this interface.

3.14. JTAG Interface

The JTAG interface provides debug access to the core of the AirPrime HL77xx modules. These JTAG signals are accessible through solder-able test points.

Refer to the following table for the pad description of the JTAG interface.

Table 28. JTAG Pad Description

Pad Number	Signal Name	Function
236	JTAG_RESET	JTAG RESET
237	JTAG_TCK	JTAG Test Clock
238	JTAG_TDO	JTAG Test Data Output
239	JTAG_TMS	JTAG Test Mode Select
240	JTAG_TRST	JTAG Test Reset
241	JTAG_TDI	JTAG Test Data Input

Note: It is recommended to provide access through Test Points to this interface the JTAG pads (for Failure Analysis debugging). All signals listed in the table above should be outputs on the customer board to allow JTAG debugging.

Refer to the following table for the electrical characteristics of the JTAG interface.

Table 29. JTAG Electrical Characteristics

Symbol	Parameter	Minimum	Typical	Maximum	Unit
F_{tck}	JTAG_TCK clock period	0.038 (TBC)	26 (TBC)	78 (TBC)	MHz
t_{c2}	JTAG_TCK clock period high	12 (TBC)	-	-	ns
t_{c3}	JTAG_TCK clock period low	12 (TBC)	-	-	ns
t_{c4}	JTAG_TDI setup time to JTAG_TCK	12 (TBC)	-	-	ns
t_{c5}	JTAG_TDI hold time from JTAG_TCK	10 (TBC)	-	-	ns
t_{c6}	JTAG_TDO valid before JTAG_TCK low-end	-	0 (TBC)	-	s
t_{c7}	JTAG_TDO valid after JTAG_TCK high begin	-	20 (TBC)	-	ns

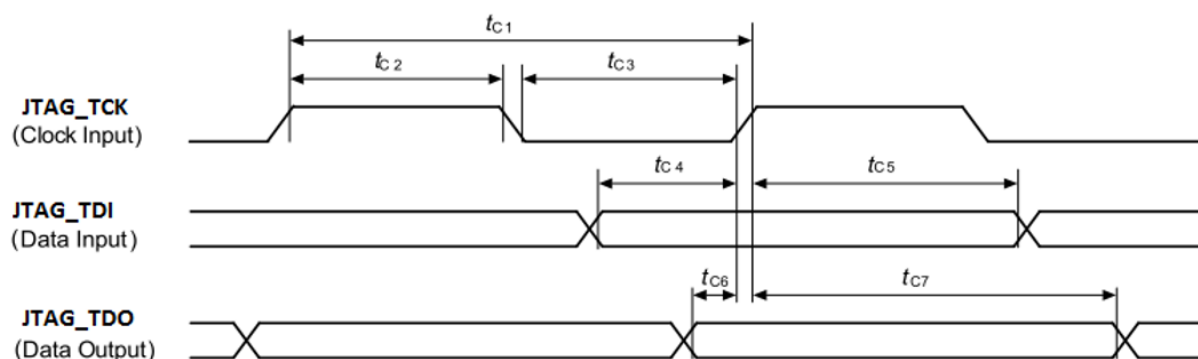

Figure 7. JTAG Timing Waveform

3.15. Wake Up Signal (WAKE-UP)

The AirPrime HL77xx modules provide one WAKE-UP signal.

The WAKE-UP signal is used to wake the system up from ultra-low power modes (from OFF or Sleep modes, FAST_SHUTDOWN, or after a software power off). This signal should be set to high level (external 1.8V) for at least (TBD) ms until the system is active to wake the module up from these modes.

The system will not be allowed to go into ultra-low or off mode for as long as this signal is kept high.

By default, the software waits for a high state to wake-up.

Note: The module has an embedded pull-down on this signal. After a power off mode, the only way to restart the module is to perform a hardware power off then power on if this signal is not used.

Refer to the following table for the pad description of the WAKE-UP interface.

Table 30. WAKE-UP Pad Description

Pad Number	Signal Name	I/O	I/O Type	Description
19	WAKE-UP	I	1.8V	WAKE-UP

Refer to the following table for the electrical characteristics of the WAKE-UP interface.

Table 31. WAKE-UP Electrical Characteristics

I/O Type	Parameter	Minimum	Typical	Maximum	Unit
Digital	V _{IL}			0.3	V
	V _{IH}	0.7 x VDDIO*			V

* VDDIO = VGPIO = 1.8 V.

3.16. Fast Shutdown Signal (FAST_SHUTDOWN)

The AirPrime HL77xx modules provide one FAST_SHUTDOWN signal.

Refer to the following table for the pad description of the FAST_SHUTDOWN interface.

Table 32. FAST_SHUTDOWN Pad Description

Pad Number	Signal Name	I/O	I/O Type	Description
65	FAST_SHUTDOWN	I	1.8V	Shuts down the module without deregistration from the network

Refer to the following table for the electrical characteristics of the FAST_SHUTDOWN interface.

Table 33. FAST_SHUTDOWN Electrical Characteristics

I/O Type	Parameter	Minimum	Typical	Maximum	Unit
Digital	V _{IL}			0.3xVDDIO	V
	V _{IH}	0.7 x VDDIO			V

* VDDIO = VGPIO = 1.8 V.

3.17. PWM

The AirPrime HL77xx modules provide one PWM signal that can be used in conjunction with an external transistor for driving a vibrator, or a backlight LED.

The PWM uses two 7-bit unsigned binary numbers – one for the output period and one for the pulse width or the duty cycle.

The relative timing for the PWM output is shown in the figure below.

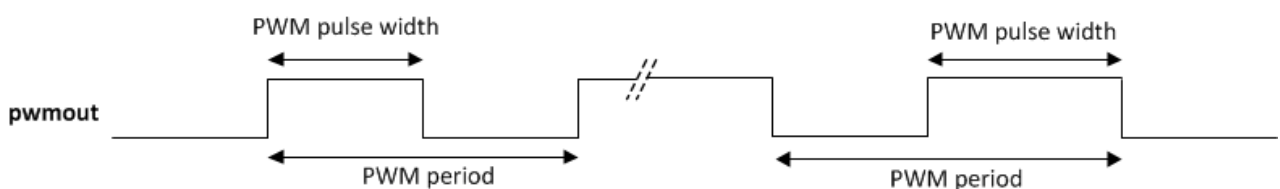

Figure 8. Relative Timing for the PWM Output

Refer to the following table for the pad description of the PWM interface.

Table 34. PWM Pad Description

Pad Number	Signal Name	I/O	I/O Type	Description
58	PWM0	O	1.8V	PWM output

Refer to the following table for the electrical characteristics of the PWM interface.

Table 35. PWM Electrical Characteristics (TBC)

Parameter	Conditions	Minimum	Typical	Maximum	Unit
V _{OH}	High impedance load	--	1.8	-	V
V _{OL}	-	-	-	0.2	V
I _{PEAK}	-	-	-	8	mA
Frequency	-	25.6	-	1625	kHz
Duty cycle	-	1	-	99	%

3.18. RF Interface

The RF interface of the AirPrime HL77xx modules allow the transmission of RF signals. This interface has a 50Ω nominal impedance.

3.18.1. RF Connection

A 50Ω (with maximum VSWR 1.1:1, and 0.5dB loss) RF track is recommended to be connected to standard RF connectors such as SMA, UFL, etc. for antenna connection.

Refer to the following table for the pad description of the RF interface.

Table 36. RF Pad Connection

Pad Number	RF Signal	Impedance	VSWR Rx (max)	VSWR Tx (max)
49	RF_MAIN	50Ω	1.5:1	1.5:1

3.18.2. RF Performances

RF performances are compliant with 3GPP recommendation TS 36.101.

The following table shows typical RX sensitivity with the reference sensitivity level at 95% of the maximum throughput, using the following 3GPP test conditions:

- 3GPP Pattern
- QPSK modulation
- 4RB_DL, 6RB_UL
- 23dBm UL power

Table 37. Typical RX Sensitivity

LTE Band	dBm/15kHz	dBm/1.4MHz	3GPP Limit (dBm)
2	-126	-107, 4	-100.3
3	-126	-107, 4	-99.3
4	-125.5	-106, 9	-102.3
12	-125.5	-106, 9	-99.3
13	-126.5	-107, 9	-99.3
28	-126.5	-107, 9	-100.7



4. Mechanical Drawings

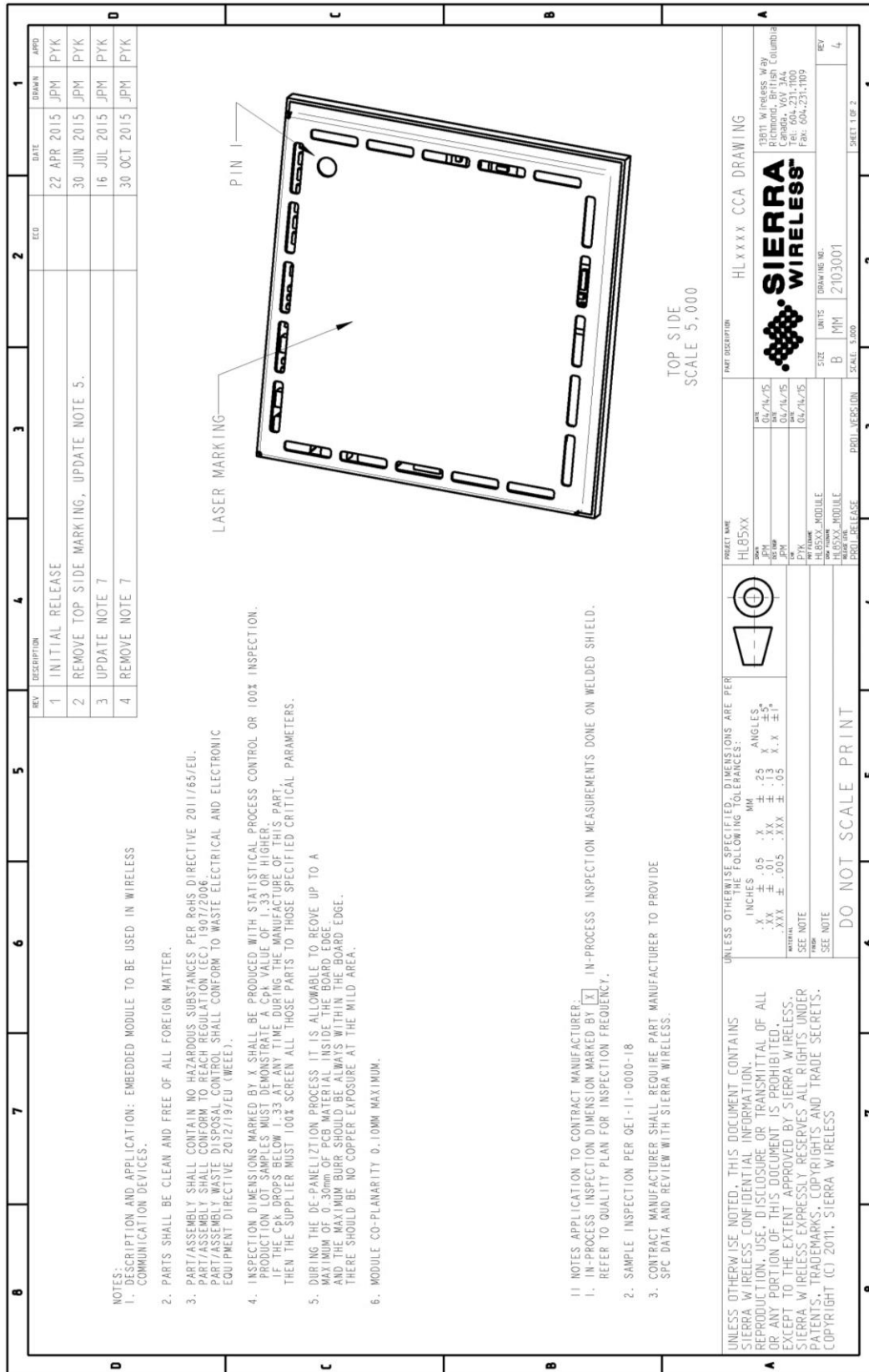

Figure 9. Mechanical Drawing

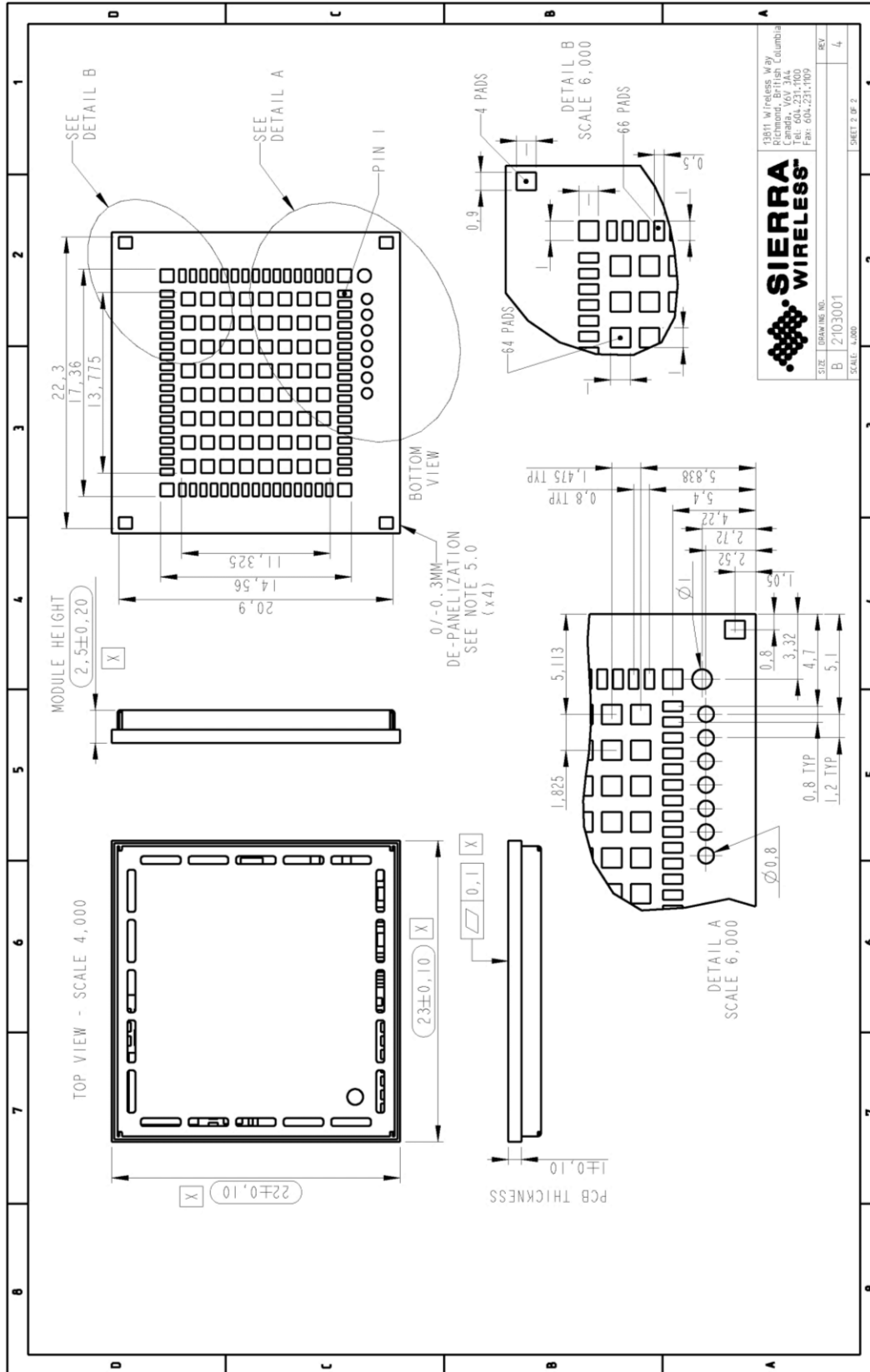

Figure 10. Dimensions and Footprint Drawing

5. Design Guidelines

5.1. Power-Up Sequence

Apply voltage to the VBATT pin for at least 10 ms (TBC) prior to applying a low-level logic to the PWR_ON_N pin.

Apply a low-level logic to the PWR_ON_N pin (pin 59); within approximately 25ms, VGPI0 will appear to be at 1.8V. Either UART1 or the USB interface could be used to send AT commands. The AT command interface is available in about 25 seconds (TBC) after PWR_ON_N for either UART or USB.

When using UART, the AT command interface is available after the transition of UART1_CTS from high to low level.

When using a USB connection, the AirPrime HL77xx module will start communicating with the host after USB enumeration. The time when AT commands can be sent will depend on the initialization time on the USB host.

Note: As PWR_ON_N is internally pulled up with 1M Ω , an open collector or open drain transistor must be used for ignition.

5.2. Module Switch-Off

AT commands **AT+CPOF** and **AT+CPWROFF** enables the user to properly switch the AirPrime HL77xx module off.

5.3. Sleep Mode Management

AT command **AT+KSLEEP** enables sleep mode configuration; this command can only be used with serial link UART1.

AT+KSLEEP=0 :

- The module is active when the DTR signal is active (low electrical level).
- When DTR is deactivated (high electrical level), the module enters sleep mode after a while.
- On DTR activation (low electrical level), the module wakes up.

AT+KSLEEP=1 :

- The module determines when it enters sleep mode (when no more tasks are running).
- Any character on the serial link wakes the module up. The first character is lost.

AT+KSLEEP=2 : The module never enters sleep mode.

Note: The DTR signal must only be set to low-level "0" to wake up from Sleep mode. This pin must be set to high-level "1" (1.8V) or left floating (internal pull-up) for all other modes.

5.4. Power Supply Design

The AirPrime HL77xx module should not be supplied with voltage over 4.5V even temporarily or however briefly.

If the system’s main board power supply unit is unstable or if the system’s main board is supplied over 4.5V, even in the case of transient voltage presence on the circuit, the module’s power amplifier may be severely damaged.

To avoid such issues, add a voltage limiter to the module’s power supply lines so that VBATT and VBATT_PA signal pads will never receive a voltage surge over 4.5V. The voltage limiter can be as simple as a Zener diode with decoupling capacitors as shown in the diagram below.

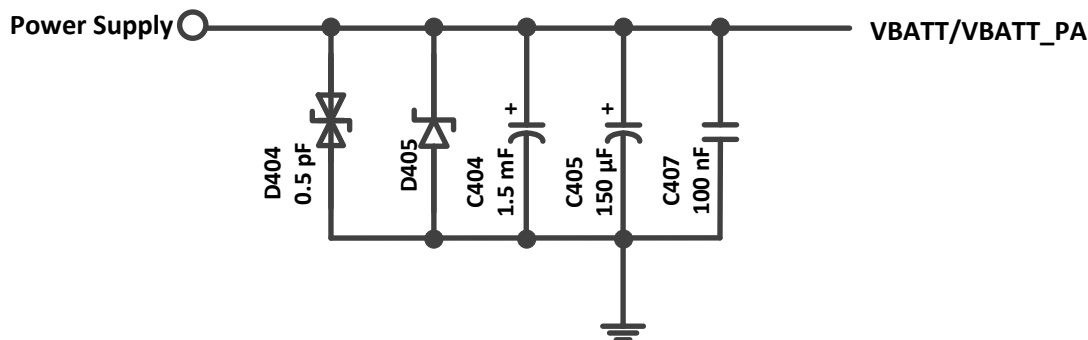

Figure 11. Voltage Limiter Example

5.5. Power On Connection Examples

Refer to the following figures for PWR_ON_N connection examples using a switch and an open collector transistor.

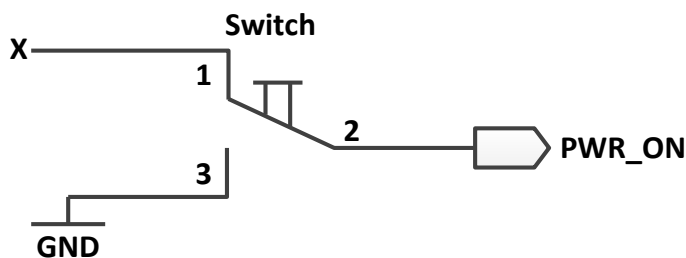

Figure 12. PWR_ON_N Connection Example with Switch

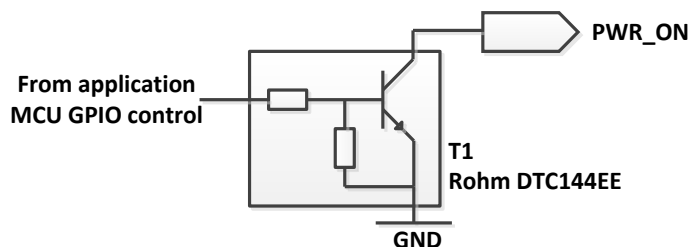

Figure 13. PWR_ON_N Connection Example with an Open Collector Transistor

5.6. USIM1 Application

The AirPrime HL77xx modules support one USIM1 slot.

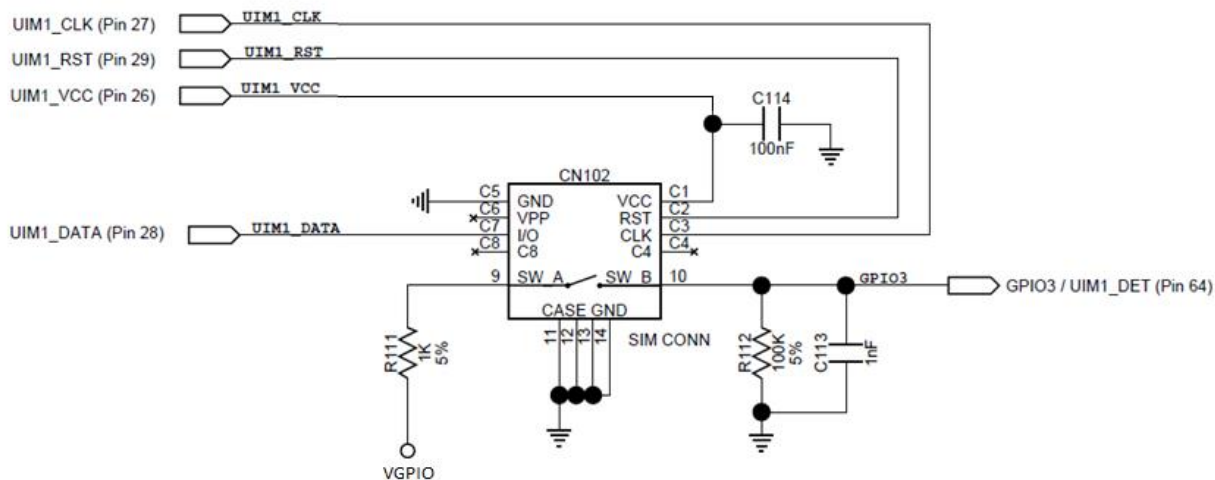

Figure 14. Design Application with USIM1 Slot

5.7. EMC and ESD Guidelines for USIM1 Card

Decoupling capacitors must be added according to the drawing below, as close as possible to the UIM1 card connectors on UIM1_CLK, UIM1_RESET, UIM1_VCC, UIM1_DATA and UIM1_DET signals to avoid EMC issues and to comply with the requirements of ETSI and 3GPP standards covering the USIM1 electrical interface.

A typical schematic including USIM1 detection is provided below.

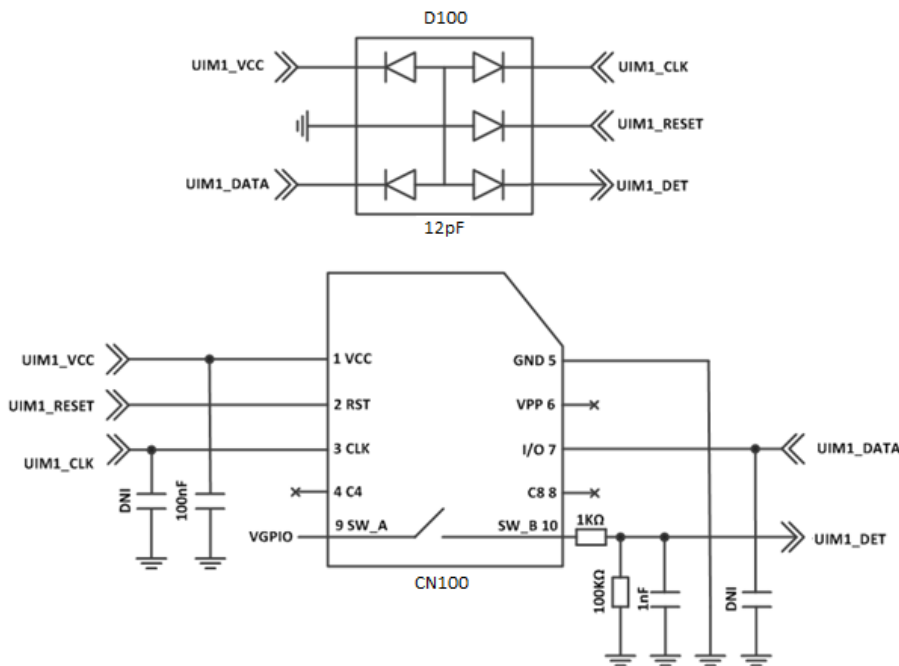

Figure 15. EMC and ESD Components Close to the USIM1.

Sierra Wireless recommends using a ESDALC6V1-5P6 ESD diode for D100.

5.8. ESD Guidelines for USB

When the USB interface is externally accessible, it is required to have ESD protection on the USB_D+ and USB_D- signals.

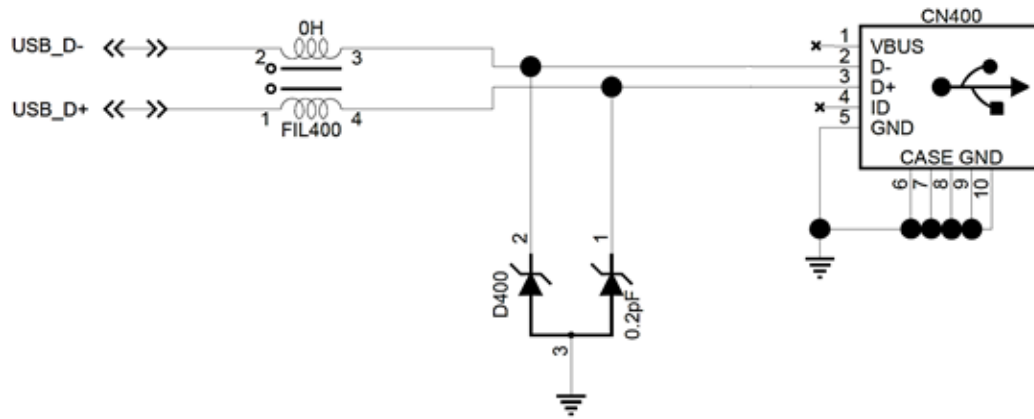

Figure 16. ESD Protection for USB

Sierra Wireless recommends using the following components:

- FIL400: 90Ω DLP0NSN900HL2L EMC filter
- D400: RCLAMP0503N or ESD5V3U2U-03LRH ESD diode

5.9. PWM

Refer to the following figures for examples of using the PWM0 signal for driving an LED or a BUZZER.

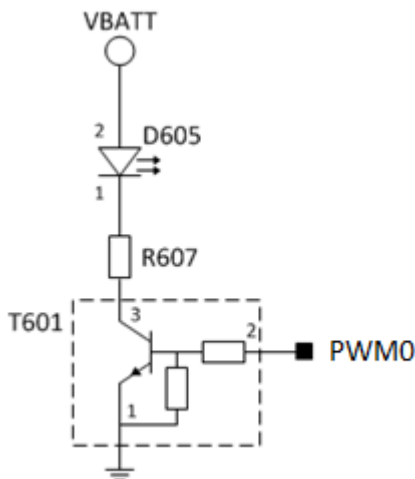

Figure 17. Example of an LED Driven by the PWM0 Output

The value of R607 can be harmonized depending on LED (D605) characteristics.

The recommended digital transistor to use for T601 is the DTC144EE from ROHM.

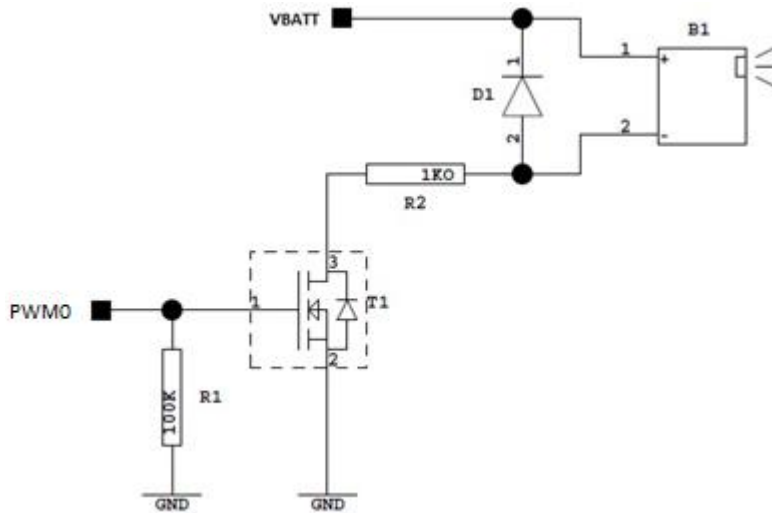

Figure 18. Example of a BUZZER Driven by the PWM0 Output

The recommended MOS transistor to use for T1 is the RUM003N02 from ROHM, and the recommended diode to use for D1 is the BAS16W from NXP.



6. Reliability Specification (TBC)

AirPrime HL77xx modules will be tested against the Sierra Wireless Industrial Reliability Specification defined below.

6.1. Reliability Compliance

AirPrime HL77xx modules connected on a development kit board application are targeted to be compliant with the following requirements.

Table 38. Standards Conformity

Abbreviation	Definition
IEC	International Electro technical Commission
ISO	International Organization for Standardization

6.2. Reliability Prediction Model

6.2.1. Life Stress Test

The following tests the AirPrime HL77xx modules' product performance.



Table 39. Life Stress Test

Designation	Condition
Performance Test PT3T & PTRT 	Standard: N/A
	Special conditions: <ul style="list-style-type: none">• Temperature:<ul style="list-style-type: none">▪ Class A: -30°C to +70°C▪ Class B: -40°C to +85°C▪ Rate of temperature change: $\pm 3^{\circ}\text{C}/\text{min}$• Recovery time: 3 hours
	Operating conditions: Powered
	Duration: 14 days

6.2.2. Environmental Resistance Stress Tests

The following tests the AirPrime HL77xx modules' resistance to extreme temperature.

Table 40. Environmental Resistance Stress Tests

Designation	Condition
Cold Test Active COTA 	Standard: IEC 680068-2-1, Test Ad
	Special conditions: <ul style="list-style-type: none"> • Temperature: -40°C • Temperature variation: 1°C/min
	Operating conditions: Powered ON with a power cycle of 1 minute ON and 2 minutes OFF
	Duration: 3 days
Resistance to Heat Test RH 	Standard: IEC 680068-2-2, Test Bb
	Special conditions: <ul style="list-style-type: none"> • Temperature: +85°C • Temperature variation: 1°C/min
	Operating conditions: Powered ON with a power cycle of 15 minutes ON and 15 minutes OFF
	Duration: 50 days

6.2.3. Corrosive Resistance Stress Tests

The following tests the AirPrime HL77xx modules' resistance to corrosive atmosphere.

Table 41. Corrosive Resistance Stress Tests

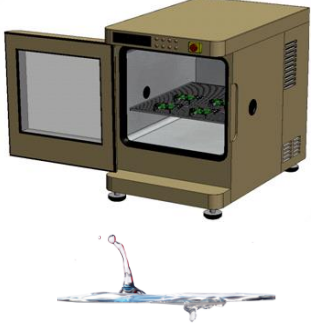

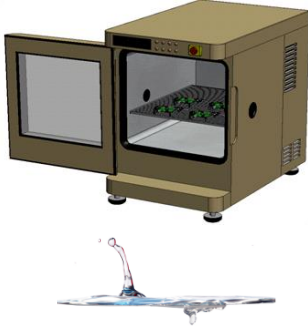
Designation	Condition
Humidity Test HUT 	Standard: IEC 60068-2-3, Test Ca
	Special conditions: <ul style="list-style-type: none"> • Temperature: +65°C • RH: 95% • Temperature variation: 3 +/- 0.6°C/min
	Operating conditions: Powered on, DUT is powered up for 15 minutes and OFF for 15 minutes
	Duration: 10 days

Designation	Condition
Component Solder Wettability CSW 	Standard: JESD22 – B102, Method 1/Condition C, Solderability Test Method
	Special conditions: <ul style="list-style-type: none"> • Test method: Dip and Look Test with Steam preconditioning 8 h +/- 15min. dip for 5 +0/-0.5 seconds
	Operating conditions: Un-powered
	Duration: 1 day
Moist Heat Cyclic Test MHCT 	Standard: IEC 60068-2-30, Test Db
	<ul style="list-style-type: none"> • Special conditions: • Upper temperature: +40 ± 2°C • Lower temperature: +25 ± 5°C • RH: <ul style="list-style-type: none"> ▪ Upper temperature: 93% ▪ Lower temperature: 95% • Number of cycles: 21 (1 cycle/24 hours) • Temperature Variation: 3 +/- 0.6°C/min
	Operating conditions: Powered ON for 15 minutes during each 3 hours ramp up and 3 hours ramp down (in middle) for every cycle
	Duration: 21 days

6.2.4. Thermal Resistance Cycle Stress Tests

The following tests the AirPrime HL77xx modules' resistance to extreme temperature cycling.

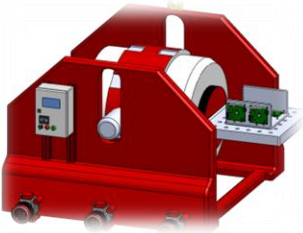

Table 42. Thermal Resistance Cycle Stress Tests

Designation	Condition
Thermal Shock Test TSKT 	Standard: IEC 60068-2-14, Test Na
	Special conditions: <ul style="list-style-type: none"> • Temperature: -30°C to +80°C • Temperature Variation: less than 30s • Number of cycles: 600 • Dwell Time: 10 minutes
	Operating conditions: Un-powered
	Duration: 9 days
Temperature Change TCH 	Standard: IEC 60068-2-14, Test Nb
	Special conditions: <ul style="list-style-type: none"> • Temperature: -40°C to +90°C • Temperature Variation: 3 +/- 0.6°C/min • Number of cycles: 400 • Dwell Time: 10 minutes
	Operating conditions: Un-powered
	Duration: 29 days

6.2.5. Mechanical Resistance Stress Tests

The following tests the AirPrime HL77xx modules' resistance to vibrations and mechanical shocks.

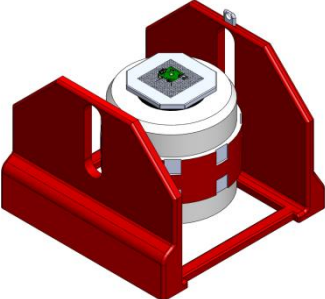
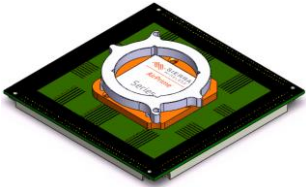

Table 43. Mechanical Resistance Stress Tests

Designation	Condition
Sinusoidal Vibration Test SVT 	Standard: IEC 60068-2-6, Test Fc
	Special conditions: <ul style="list-style-type: none"> • Frequency range: 16 Hz to 1000 Hz • Displacement: 0.35mm (peak-peak) • Acceleration: <ul style="list-style-type: none"> ▪ 5G from 16 to 62 Hz ▪ 3G from 62 to 200 Hz ▪ 1G from 200 to 1000 Hz • Sweep rate: 1 octave / cycle • Number of Sweep: 20 sweeps/axis • Sweep direction: $\pm X$, $\pm Y$, $\pm Z$
	Operating conditions: Un-powered
	Duration: 2 days
Random Vibration Test RVT 	Standard: IEC 60068-2-64, Test Fh
	Special conditions: <ul style="list-style-type: none"> • Frequency range: 10 Hz – 2000 Hz • Power Spectral Density in $[(m/s^2)^2/Hz]$ <ul style="list-style-type: none"> ▪ g^2/Hz at 10Hz ▪ g^2/Hz at 250Hz ▪ 0.005 g^2/Hz at 1000Hz ▪ 0.005 g^2/Hz at 2000Hz • Peak factor: 3 • Duration per Axis: 1 hr / axis
	Operating conditions: Un-powered
	Duration: 1 day
Mechanical Shock Test MST 	Standard: IEC 60068-2-27, Test Ea
	Special conditions: <ul style="list-style-type: none"> • Shock Test 1: <ul style="list-style-type: none"> ▪ Wave form: Half sine ▪ Peak acceleration: 30g ▪ Duration: 11ms ▪ Number of shocks: 8 ▪ Direction: $\pm X$, $\pm Y$, $\pm Z$ • Shock Test 2: <ul style="list-style-type: none"> ▪ Wave form: Half sine ▪ Peak acceleration: 100g ▪ Duration: 6ms ▪ Number of shocks: 3 ▪ Direction: $\pm X$, $\pm Y$, $\pm Z$
	Operating conditions: Un-powered
	Duration: 72 hours

6.2.6. Handling Resistance Stress Tests

The following tests the AirPrime HL77xx modules' resistance to handling malfunctions and damage.

Table 44. Handling Resistance Stress Tests

Designation	Condition
ESDC Test 	Standard: JESD22-A114, JESD22-A115, JESD22-C101
	Special conditions: <ul style="list-style-type: none"> HBM (Human Body Model): 1KV (Class 1C) MM (Machine Model): 200V CDM (Charged Device Model): 250V (Class II)
	Operating conditions: Powered
	Duration: 3 days
ESD Test 	Standard: IEC 61000-4-2
	Special conditions: <ul style="list-style-type: none"> Contact Voltage: $\pm 2\text{kV}$, $\pm 4\text{kV}$, $\pm 6\text{kV}$ Air Voltage: $\pm 2\text{kV}$, $\pm 4\text{kV}$, $\pm 8\text{kV}$
	Operating conditions: Powered
	Duration: 3 days
Free Fall Test FFT 1 	Standard: IEC 60068-2-32, Test Ed
	Special conditions: <ul style="list-style-type: none"> Number of drops: 2 drops per unit Height: 1m
	Operating conditions: Un-powered
	Duration: 6 hours



7. FCC Legal Information

The HL7718 and HL7748 modules have been granted modular approval for mobile applications. Integrators may use the HL7718 or HL7748 modules in their final products without additional FCC certification if they meet the following conditions. Otherwise, additional FCC approvals must be obtained.

1. At least 20 cm separation distance between the antenna and the user's body must be maintained at all times.
2. To comply with FCC regulations limiting both maximum RF output power and human exposure to RF radiation, the maximum antenna gain including cable loss in a mobile-only exposure condition must not exceed:

For HL7718: 2 dBi in Band 13

For HL7748:

- 9.0 dBi in Band 2
 - 6.0 dBi in Bands 4 and 12
3. The HL7718 and HL7748 modules must not transmit simultaneously with other collocated radio transmitters within a host device.
 4. The RF signal must be routed on the application board using tracks with a 50Ω characteristic impedance. Basically, the characteristic impedance depends on the dielectric, the track width and the ground plane spacing. In order to respect this constraint, Sierra Wireless recommends using MicroStrip or StripLine structure and computing the Tracks width with a simulation tool (like AppCad shown in the figure below and that is available free of charge at <http://www.agilent.com>).

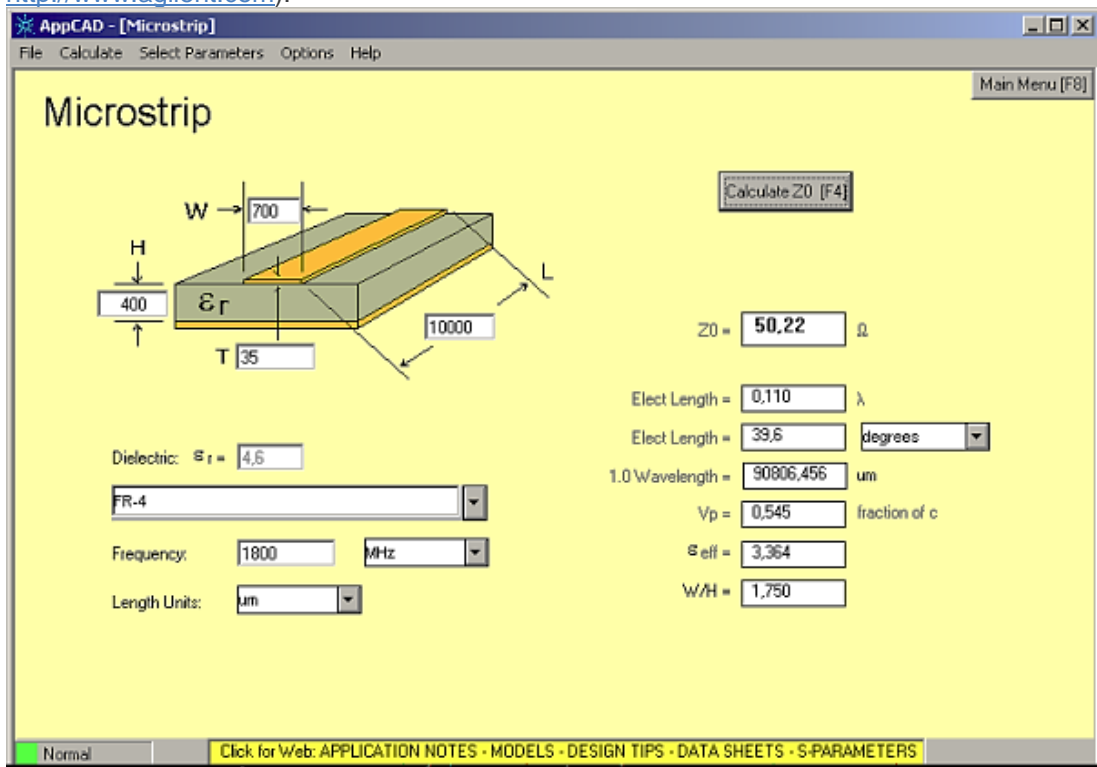

If a multi-layered PCB is used, the RF path on the board must not cross any signal (digital, analog or supply).

If necessary, use StripLine structure and route the digital line(s) "outside" the RF structure. An example of proper routing is shown in the figure below.



Stripline and Coplanar design requires having a correct ground plane at both sides. Consequently, it is necessary to add some vias along the RF path. It is recommended to use Stripline design if the RF path is fairly long (more than 3cm), since MicroStrip design is not shielded. Consequently, the RF signal (when transmitting) may interfere with neighbouring electronics (AF amplifier, etc.). In the same way, the neighbouring electronics (micro-controllers, etc.) may degrade the reception performances. The GSM/GPRS connector is intended to be directly connected to a 50Ω antenna and no matching is needed.

5. A label must be affixed to the outside of the end product into which the HL7718 or HL7748 module is incorporated, with a statement similar to the following:

This device contains FCC ID: <FCC ID as listed in the table below>

Embedded Module	FCC ID
HL7718	N7NHL7718
HL7748	N7NHL7748

6. A user manual with the end product must clearly indicate the operating requirements and conditions that must be observed to ensure compliance with current FCC RF exposure guidelines.

The end product with an embedded HL7718 or HL7748 module may also need to pass the FCC Part 15 unintentional emission testing requirements and be properly authorized per FCC Part 15.

Note: If this module is intended for use in a portable device, you are responsible for separate approval to satisfy the SAR requirements of FCC Part 2.1093.



8. Ordering Information

Table 45. Ordering Information

Model Name	Description	Part Number
HL7718	HL7718 embedded module	Contact Sierra Wireless for the latest SKU
HL7748	HL7748 embedded module	Contact Sierra Wireless for the latest SKU
HL7749	HL7749 embedded module	Contact Sierra Wireless for the latest SKU
DEV-KIT	HL Series Development Kit	6000620



9. Terms and Abbreviations

Abbreviation	Definition
ADC	Analog to Digital Converter
AGC	Automatic Gain Control
AT	Attention (prefix for modem commands)
CDMA	Code Division Multiple Access
CF ³	Common Flexible Form Factor
CLK	Clock
CODEC	Coder Decoder
CPU	Central Processing Unit
DAC	Digital to Analog Converter
DTR	Data Terminal Ready
EGNOS	European Geostationary Navigation Overlay Service
EMC	Electro-Magnetic Compatibility
EMI	Electro-Magnetic Interference
EN	Enable
ESD	Electro-Static Discharges
ETSI	European Telecommunications Standards Institute
FDMA	Frequency-division multiple access
GAGAN	GPS aided geo augmented navigation
GLONASS	Global Navigation Satellite System
GND	Ground
GNSS	Global Navigation Satellite System
GPIO	General Purpose Input Output
GPRS	General Packet Radio Service
GSM	Global System for Mobile communications
Hi Z	High impedance (Z)
IC	Integrated Circuit
IMEI	International Mobile Equipment Identification
I/O	Input / Output
LED	Light Emitting Diode
LNA	Low Noise Amplifier
MAX	Maximum
MIN	Minimum
MSAS	Multi-functional Satellite Augmentation System
N/A	Not Applicable
PA	Power Amplifier
PC	Personal Computer
PCB	Printed Circuit Board
PCL	Power Control Level
PLL	Phase Lock Loop
PWM	Pulse Width Modulation
QZSS	Quasi-Zenith Satellite System

Abbreviation	Definition
RF	Radio Frequency
RFI	Radio Frequency Interference
RMS	Root Mean Square
RST	Reset
RTC	Real Time Clock
RX	Receive
SCL	Serial Clock
SDA	Serial Data
SIM	Subscriber Identification Module
SMD	Surface Mounted Device/Design
SPI	Serial Peripheral Interface
SW	Software
PSRAM	Pseudo Static RAM
TBC	To Be Confirmed
TBD	To Be Defined
TP	Test Point
TX	Transmit
TYP	Typical
UART	Universal Asynchronous Receiver-Transmitter
UICC	Universal Integrated Circuit Card
USB	Universal Serial Bus
UIM	User Identity Module
VBATT	Main Supply Voltage from Battery or DC adapter
VSWR	Voltage Standing Wave Ratio
WAAS	Wide Area Augmentation System