



Customer Process Guidelines

HL78xx

Important Notice

Information relating to this product and the application or design described herein is believed to be reliable, however such information is provided as a guide only and Semtech assumes no liability for any errors in this document, or for the application or design described herein.

Semtech reserves the right to make changes to the product or this document at any time without notice. Buyers should obtain the latest relevant information before placing orders and should verify that such information is current and complete. Semtech warrants performance of its products to the specifications applicable at the time of sale, and all sales are made in accordance with Semtech's standard terms and conditions of sale.

SEMTECH PRODUCTS ARE NOT DESIGNED, INTENDED, AUTHORIZED OR WARRANTED TO BE SUITABLE FOR USE IN LIFE-SUPPORT APPLICATIONS, DEVICES OR SYSTEMS, OR IN NUCLEAR APPLICATIONS IN WHICH THE FAILURE COULD BE REASONABLY EXPECTED TO RESULT IN PERSONAL INJURY, LOSS OF LIFE OR SEVERE PROPERTY OR ENVIRONMENTAL DAMAGE. INCLUSION OF SEMTECH PRODUCTS IN SUCH APPLICATIONS IS UNDERSTOOD TO BE UNDERTAKEN SOLELY AT THE CUSTOMER'S OWN RISK. Should a customer purchase or use Semtech products for any such unauthorized application, the customer shall indemnify and hold Semtech and its officers, employees, subsidiaries, affiliates, and distributors harmless against all claims, costs damages and attorney fees which could arise.

The Semtech name and logo are registered trademarks of the Semtech Corporation. All other trademarks and trade names mentioned may be marks and names of Semtech or their respective companies. Semtech reserves the right to make changes to, or discontinue any products described in this document without further notice. Semtech makes no warranty, representation or guarantee, express or implied, regarding the suitability of its products for any particular purpose. All rights reserved.

Wireless Communications

Due to the nature of wireless communications, transmission and reception of data can never be guaranteed. Data may be delayed, corrupted (i.e., have errors) or be totally lost. The Semtech product should not be used in situations where failure to transmit or receive data could result in damage of any kind to the user or any other party, including but not limited to personal injury, death, or loss of property. Semtech accepts no responsibility for damages of any kind resulting from delays or errors in data transmitted or received using the Semtech product, or for failure of the Semtech product to transmit or receive such data.

Safety

Do not operate the Semtech product in areas where blasting is in progress, where explosive atmospheres may be present, near medical equipment, near life support equipment, or near any equipment which may be susceptible to any form of radio interference. In such areas, the Semtech product should be powered off.

Qualcomm Licenses

Semtech's cellular modules are sold subject to certain notices and restrictions regarding patent licenses from Qualcomm Incorporated. These notices and restrictions are available at www.sierrawireless.com/qualcomm-notices.

Sierra Wireless

Semtech Corporation acquired Sierra Wireless in January 2023. The Sierra Wireless brand is gradually being phased out. During the phase-out period, references to both “Semtech” and “Sierra Wireless” may appear in product documentation.

Contact Information

Sales information and technical support, including warranty and returns	Web: sierrawireless.com/company/contact-us/ Global toll-free number: 1-877-687-7795 6:00 am to 5:00 pm PST
Corporate and product information	Web: sierrawireless.com

Revision History

Revision number	Release date	Changes
1	February 1, 2018	Creation
1.1	February 13, 2018	Updated: <ul style="list-style-type: none"> ▪ 2.2.2 Marking Description ▪ Figure 3 Packing Label ▪ 4.1 Stencil Design
1.2	March 23, 2018	Updated: <ul style="list-style-type: none"> ▪ 3 SMT Assembly Process ▪ 4.1 Stencil Design
2	January 2, 2019	Updated: <ul style="list-style-type: none"> ▪ 2.1 Storage and Handling of HL78xx ▪ 2.2.2 Marking Description ▪ 4.1 Stencil Design
3	February 11, 2019	Updated Figure 7 Recommended Solder Resist and Paste Mask Layout
4	December 30, 2019	Updated label example (added callouts)
5	September 2022	Added Figure 5 Recommended footprint Updated 2.1.1. Storage conditions period
6	October 2023	Updated 4.3 Washing and Potting
7	October 2024	Updated: <ul style="list-style-type: none"> ▪ Figure 7 Recommended Solder Resist and Paste Mask Layout ▪ 4.3 Washing and Potting ▪ Semtech template usage
8	January 2026	Updated 4.2 Solder Reflow Profile

Contents

- Important Notice 2
- Wireless Communications..... 2
- Safety..... 2
- Qualcomm Licenses 2
- Sierra Wireless 3
- Contact Information 4
- Revision History 4

- 1: Introduction 7**

- 2: Handling 8**
 - 2.1 Storage and Handling of HL78xx Modules 8
 - 2.1.1 Storage Condition..... 8
 - 2.1.2 ESD 8
 - 2.1.3 Moisture Sensitivity..... 8
 - 2.2 Component Package 9
 - 2.2.1 Package Description 9
 - 2.2.2 Marking Description..... 9
 - 2.3 Component Packing..... 10
 - 2.3.1 Packing Description 10
 - 2.3.2 Packing Label..... 10

- 3: SMT Assembly Process 11**
 - 3.1 Lead-Free Process 11
 - 3.2 PCB Design Requirements 12
 - 3.2.1 PCB Surface Finish..... 12
 - 3.2.2 Footprint 12
 - 3.2.3 Layout Recommendations..... 14
 - 3.3 Solder Mask 15
 - 3.3.1 Layout Recommendations..... 15

4: Board Mounting Guidelines	16
4.1 Stencil Design.....	16
4.2 Solder Reflow Profile.....	17
4.3 Washing and Potting.....	18
5: Rework Guidelines	19
5.1 Component Removal.....	19
5.2 Pad Redress.....	19
5.3 Solder Paste Deposit.....	19
5.4 New Component Placement.....	20
5.5 New Component Soldering.....	20
A: Appendix	21
A.1 Reference Documents.....	21

1: Introduction

This document presents guidelines for the industrial assembly of an HL78xx Embedded Module on an application.

2: Handling

2.1 Storage and Handling of HL78xx Modules

2.1.1 Storage Condition

HL78xx modules must be stored in the following manner:

- In their sealed, original packages,
- Up to 18 months, and
- Temperature $\leq 40^{\circ}\text{C}$; RH $\leq 90\%$.

Tip: For optimal results, the recommended storage temperature is $+20^{\circ}\text{C} \pm 10$ degrees, below 60% RH.

2.1.2 ESD

The HL78xx is ESD sensitive. For ESD level information, refer to the corresponding Product Technical Specification of each product as listed in the [Reference Documents](#).

According to the HBM-ESD level of the HL78xx module, it is necessary to use detailed ESD precautions as described in the following standards:

- JEDEC standard JESD625, Requirements for Handling Electrostatic Discharge-Sensitive (ESDS) Devices
- ANSI/ESD S20.20: Protection of Electrical and Electronics Parts, Assemblies and Equipment

2.1.3 Moisture Sensitivity

The HL78xx is sensitive to moisture absorption:

- MSL 3, 245°C , 2 reflows allowed on customer PCB
- See additional details in section 4.2 Solder Reflow Profile

Caution: If tape and reel vacuum pack is open for more than 168h, material should be baked at 40°C for 13 days. If parts are on tray, baking conditions are 24 hours minimum at 85°C .

It is recommended to follow the standard MSL procedure, as described in the following standard:

- IPC/JEDEC J-STD-033 - Handling, Packing, Shipping and Use of Moisture / Reflow Sensitive Surface Mount Devices.

2.2 Component Package

2.2.1 Package Description

The HL78xx module is a scalable QFN (quad flat no lead) package, 15x18x2.4 mm, pitch 0.8 mm with 86 terminals.

The terminals include:

- 66 inner signal pads
- 4 mechanical corner pads
- 16 ground pads

The PCB material is FR4. Plating is NiAu (3 μm < Nickel < 8 μm and 0.05 < Gold < 0.13 μm).

For additional information, refer to the corresponding Product Technical Specification of each product as listed in the [Reference Documents](#).

2.2.2 Marking Description

Marking contents and marking methods on the module may differ between each variant of the product family.

Marking method is by laser marking, but there are rare instances where the modules are marked with a paper label instead.

Common label content includes:

- Model Name
- Serial Number and IMEI Number (data matrix bar codes)
- Fabrication Country
- Pin 1 indicator for solder-down modules

Note: Regulatory compliancy markings are not present due to space limitations. Details regarding regulatory numbers are available in the Product Technical Specification.

The example below is not contractual and do not show exact contents of the label. Label contents may also be rearranged to fit any additional customer-specific need or market segment and can change without notice at the sole discretion of Semtech.

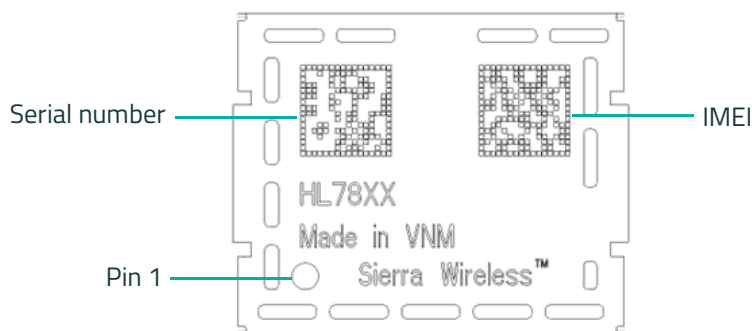

Figure 2-1: Figure 1.Product Label Example

2.3 Component Packing

2.3.1 Packing Description

The HL78xx module is delivered in tape and reel.

Quantity per tape and reel is 750.

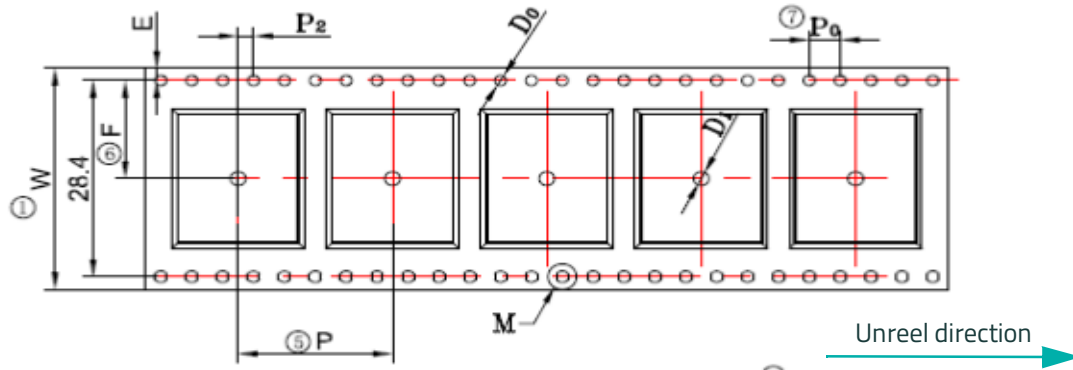

Figure 2-2: HL78xx Tape and Reel

P	P0	W
20.0 mm	4.0 mm	32.0 mm

2.3.2 Packing Label

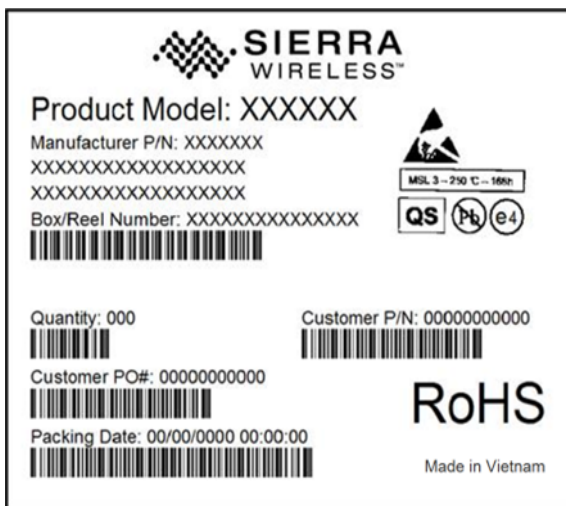

Figure 2-3: Packing Label

3: SMT Assembly Process

This section presents information and recommendations for the industrial assembly of the HL78xx on the application.

Note: The HL78xx should be assembled by reflow process.

For customers planning to use both HL78xx (15x18 mm - 16 ground pads) and larger HL modules (22x23 mm - 64 ground pads), Semtech advises to use the larger HL footprint (22x23 mm) and 2 stencils (one recommended for each product).

Using larger HL modules (64 ground pads) on HL78xx copper footprint (16 ground pads) has not yet been evaluated thermally. This will be confirmed in future document revisions.

3.1 Lead-Free Process

In compliance with directive 2011/65/CE and its amendments, Semtech products do not contain the following hazardous substances, unless with valid exemptions.

Table 3-1: Restricted Substances

Substance Name	Limit (%)
Lead	0.1%
Mercury	0.1%
Cadmium	0.01%
Hexavalent chromium	0.1%
Polybrominated biphenyls (PBB)	0.1%
Polybrominated diphenyl ethers (PBDE)	0.1%
Bis(2-ethylhexyl) phthalate (DEHP)	0.1%
Butyl benzyl phthalate (BBP)	0.1%
Dibutyl phthalate (DBP)	0.1%
Diisobutyl phthalate (DIBP)	0.1%

The HL78xx module is manufactured with RoHS-compliant components and processes.

3.2 PCB Design Requirements

3.2.1 PCB Surface Finish

The PCB surface finish recommended is Electroless Nickel, immersion Gold. Organic Solderability Preservative (OSP) may also be used.

Caution: *Hot Air Solder Leveled finish (HASL) is not recommended because the process does not give consistent solder volumes on each pad because of poor pad flatness.*

3.2.2 Footprint

To produce high assembly yields and a reliable solder joint, the footprint on the customer application board should match Figure 4 below.

Note that:

- The 16 inner pads and the 4 corner pads are ground pads.
- Manufacturing tolerance for copper pads is 30 µm.

Mechanical drawings of the HL78xx footprint (including dimensions and pitch) are available in the Product Technical Specification of each product as listed in the [Reference Documents](#).

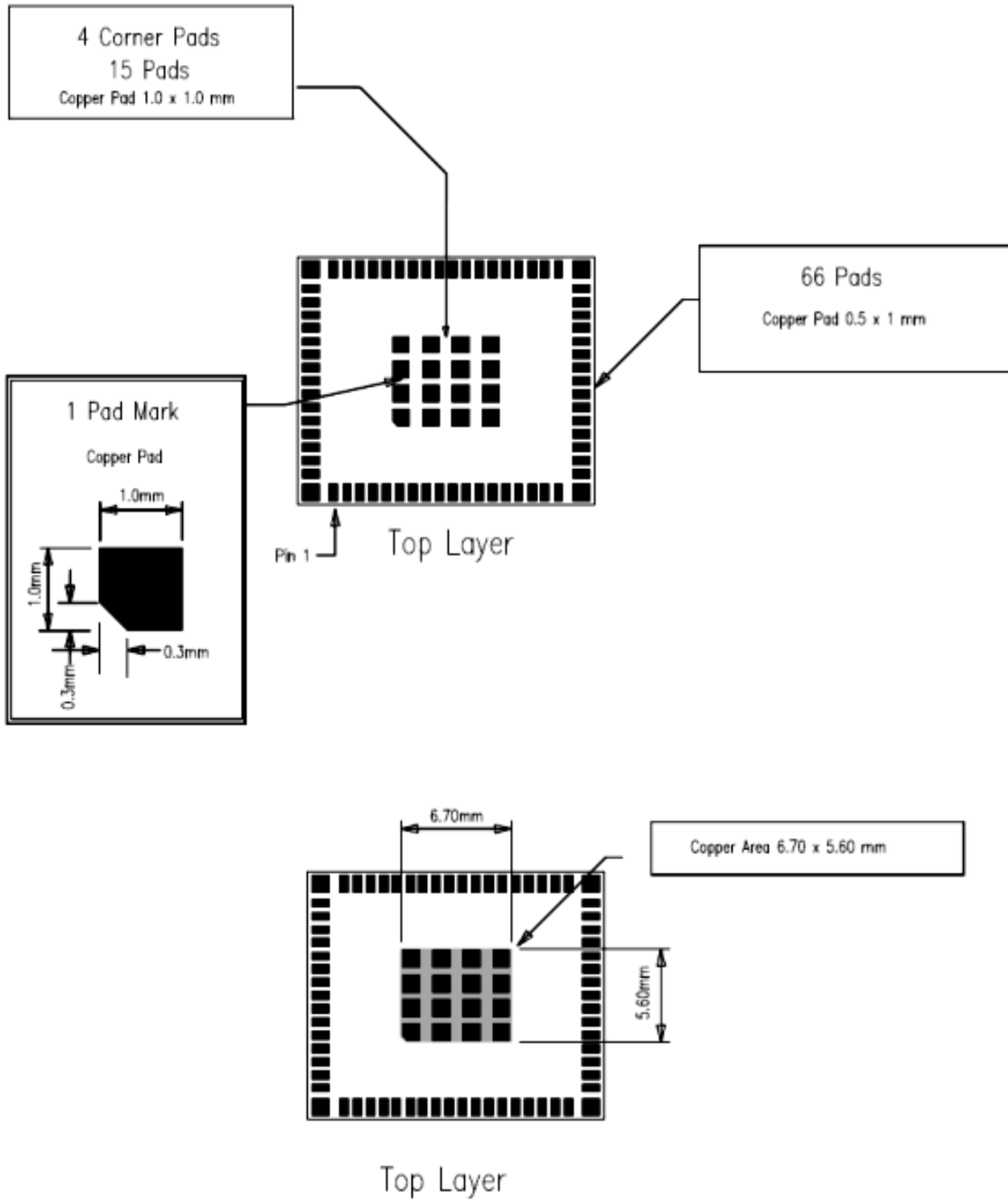

Figure 3-1: Recommended Footprint - Copper Layout

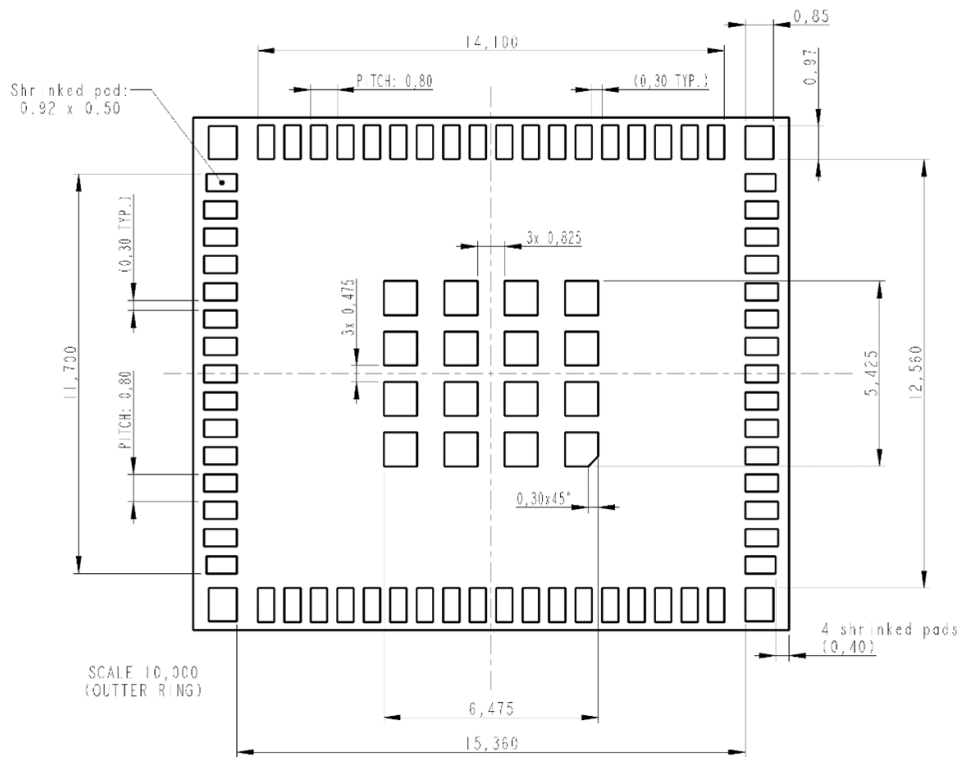

Figure 3-2: Recommended Footprint

3.2.3 Layout Recommendations

Semtech’s layout recommendations include:

- A GROUND area under the HL78xx. This ground area should be a whole area of copper with proper ground vias to provide a good grounding system between the application and the embedded module and improved thermal dissipation. It should be covered by solder resist on the non-soldered area. The ground vias may be micro-vias, filled or unfilled. Through-holes can be used in between each of the 16 ground pads (under the solder resist).
- There should not be any SIGNAL trace or hole / micro-via under the HL78xx module.
- The antenna pad and its track should be adapted according to RF constraints, based on customer layout. Refer to each corresponding Product Technical Specification for more details.
- Leave a component-free area of 2 mm around the HL78xx for accessing the surrounding components.

3.3 Solder Mask

The pads on the printed circuit board are either Solder Mask Defined (SMD) or Non-Solder Mask Defined (NSMD).

Since the copper etching process has tighter control than solder masking process, NSMD pads are preferred over SMD pads.

Moreover, NSMD pads with solder mask opening larger than the metal pad size also improve the reliability of solder joints, as this limits the stress concentration at the solder-to mask corner interface.

For external pads, the solder mask opening should be 100 μm to 150 μm larger than the pad, resulting in 50 μm to 75 μm clearance between the copper pad and solder mask. This allows for solder mask registration tolerances, depending upon the PCB fabricator's capabilities.

For ground pads, SMD pads should be used if a copper ground area is under the HL78xx module` as described in [Figure 3-2](#).

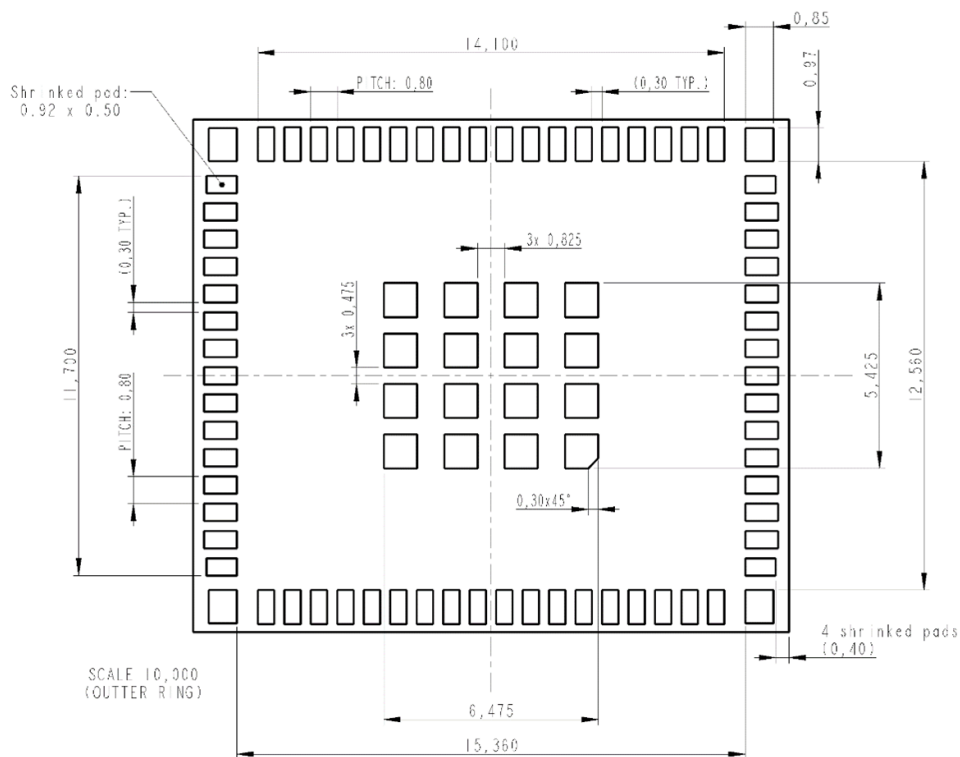

Figure 3-3: Recommended Footprint

3.3.1 Layout Recommendations

The recommended solder mask thickness on the top copper is 10 μm to 30 μm .

Refer to [Figure 4-1](#) for recommended solder resist and paste mask layout.

4: Board Mounting Guidelines

The polarity mark is indicated by a cut corner on one of the 16 ground pads on the bottom side of the module.

4.1 Stencil Design

The recommended stencil thickness is 100 μm to 125 μm . The proposed stencil design is presented in the figure below.

It is highly recommended to monitor the solder paste height, registration and proper placement during the squeegee printing.

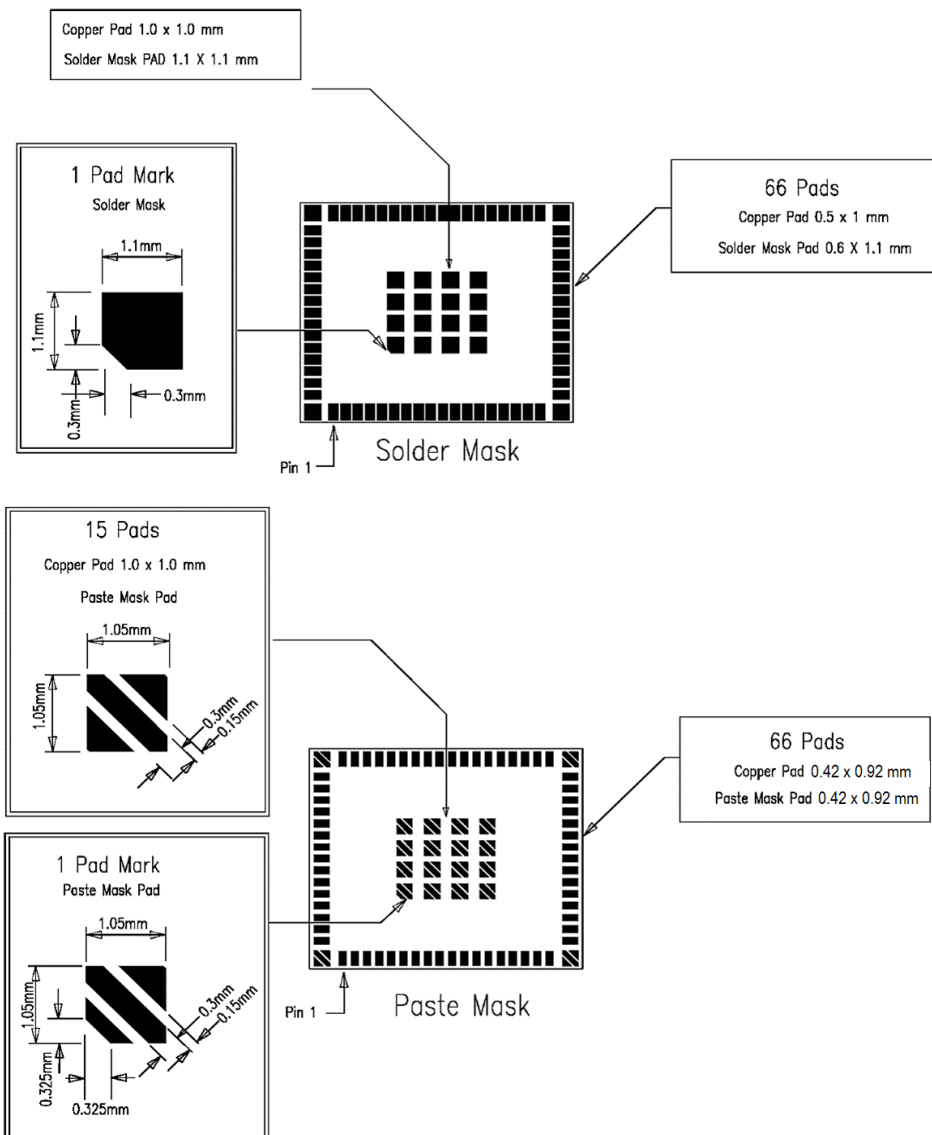

Figure 4-1: Recommended Solder Resist and Paste Mask Layout

4.2 Solder Reflow Profile

Lead-free SMT reflow profiles should be used to surface mount the HL78xx.

The reflow profile depends on PCB density and type of solder paste being used. The paste manufacturer's recommendation should also be considered to determine the proper reflow profile.

The solder reflow profile specified in Table 2 is a mandatory requirement to ensure reliable assembly.

Table 4-1: Solder Reflow Profile

Peak Temperature	245°C max
Number of reflow cycles	2

Caution: *It is recommended to use only one reflow cycle for module assembly.*

If repairs or other rework are performed on the customer board near the HL78xx, care must be taken to ensure the module is not reflowed.

When customer PCBA assembly requires dual-sided reflow cycles, Semtech strongly recommends mounting our module during the second reflow cycle to ensure optimal solder joint reliability and component integrity.

The figure below is a reflow profile example.

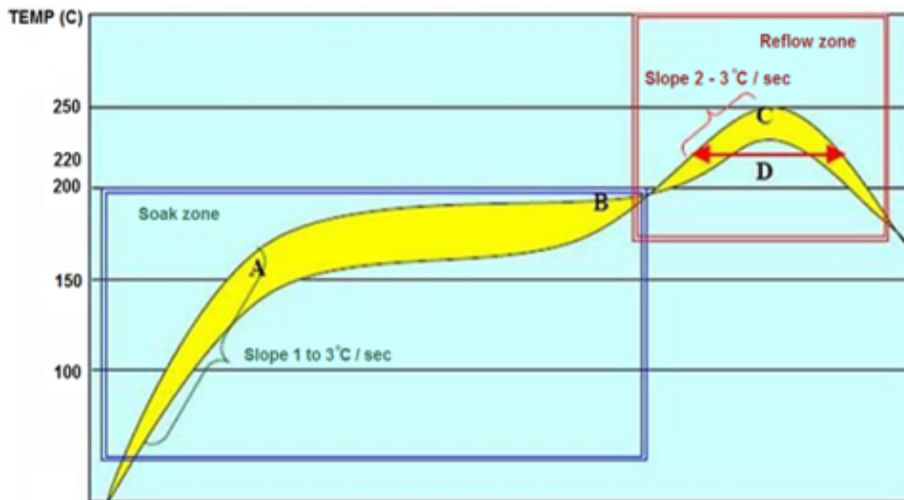

Figure 4-2: Recommended reflow profile

Additional recommendations are presented in the table below for consideration.

Factor	Recommendation
Slope at soak time	1 to 3°C / sec
Slope at reflow zone	2 to 3°C / sec
Soak time (between A and B: 150 and 190°C)	60 to 120 sec
Reflow time (D: over 220°C)	40 to 60 sec
Max temperature (C)	235 – 245°C
Slope at cooling down time	1 to 3°C / sec

Note: It is recommended to perform reflow in a nitrogen atmosphere.

4.3 Washing and Potting

Semtech has not performed potting/coating qualification tests on the HL78xx modules. Customers should pay attention to RF tracks since the ϵ_{air} (epsilon-air) will be different below the potting/coating compared to an open-air design. After potting/coating a module, RF performance should be re-checked to guarantee that no degradation compared to nominal values occurred. Semtech also recommends that potting/coating material not be allowed to ingress under the shield.

As the potting/coating process varies depending on a customer's need, it is the customer's responsibility to ensure the selected material and process parameters are compatible with the HL78xx module. If a customer's potting/coating process is found to have contributed to a failure, the unit will not be covered under warranty. Units returned for failure analysis must have all potting/coating material removed and the FSN marking must be visible.

The shield cannot be removed and no heat treatment should be used during the potting/coating material removal.

Water wash is not recommended with shielded Semtech embedded modules due to difficulty in ensuring proper drying under the shield.

Use of ultrasonic process should be avoided as it can damage the quartz crystal components.

5: Rework Guidelines

Rework tools and operating parameters are customer/application specific. Rework tools, heating profiles and the rework process should be tailored to these specific needs for optimum results.

Prior to any rework, if the component floor life has been exceeded, it is highly recommended to bake the PCB to remove moisture from the assembly. (See JEDEC J-STD-033 paragraph 6 - Board rework. If possible for the PCB and the other components of the board, apply the same baking conditions as per [Moisture Sensitivity](#)).

The pre-baking process will prevent damage to any component due to moisture vapor pressures caused during reflow.

Prior to removal, the metal shielding of the HL78xx must be glued to the module substrate, by using glue able to withstand reflow profile.

5.1 Component Removal

The step consists of reflowing the solder joints attaching components to the PCB. Ideally, the reflow profile for part removal should be the same as the one used for part attachment. However, the time above liquidus can be reduced as long as the reflow is complete.

In the removal process, it is recommended that the board should be heated from the bottom side using convective heaters and hot gas, or hot air or IR should be used on the top side of the component. Special nozzles or IR lens should be used to direct the heating in the component area and heating of adjacent components should be minimized.

Excessive hot airflow should also be avoided, as this causes the component to overheat.

Once the joints have reflowed, the vacuum lift-off should be automatically engaged for pick-up during the transition from reflow to cool down.

Warning: *If heating conditions are not properly controlled during manual hot removal from PCB assembly, package integrity can be damaged from overheating.*

5.2 Pad Redress

Once the component has been removed, the site and pads need to be cleaned properly. It is better to use the combination of a blade style conductive tool and a fluxed desoldering braid.

Once the residual solder has been removed, the land pads should be cleaned with a solvent. The solvent is usually specific to the type of solder paste used in the original assembly and the paste manufacturer's recommendations should be followed.

5.3 Solder Paste Deposit

Once the PCB is properly cleaned and inspected, solder paste should be applied on the solder land (on the component itself or on the customer PCB) with a mini-stencil which has same thickness and apertures as the stencil used for original attachment.

5.4 New Component Placement

A slip-beam optical system should be used to align the component to the PCB. This method will display an image of the land pad overlaid on the mating footprint and aid in proper alignment. Similar to paste printing, the alignment should be done under magnification of 50x to 100x.

5.5 New Component Soldering

The reflow profile developed during original attachment or removal should be used to attach the new component.

A: Appendix

For more details, several references can be consulted, as detailed below.

A.1 Reference Documents

Note: The list of HL78xx variants below may not be exhaustive. This document is applicable to all HL78xx variants with a dimension of 15x18 mm.

- HL7800 Product Technical Specification
Reference number: 41111094
- HL7802 Product Technical Specification
Reference number: 41112974
- JEDEC standard JESD625, Requirements for Handling Electrostatic -Discharge – Sensitive (ESDS) Devices
- ANSI/ESD S20.20: Protection of Electrical and Electronics Parts, Assemblies and Equipment
- IPC/JEDEC J-STD-033 – Handling, Packing, Shipping and Use of Moisture / Reflow Sensitive Surface Mount Devices