



AirLink LX60

Hardware User Guide

Safety and Hazards

Do not operate the Semtech product in areas where blasting is in progress, near medical equipment, near life support equipment, or any equipment which may be susceptible to any form of radio interference. In such areas, the Semtech product **MUST BE POWERED OFF**. The Semtech product can transmit signals that could interfere with this equipment.

The driver or operator of any vehicle should not operate the Semtech product while in control of a vehicle. Doing so will detract from the driver or operator's control and operation of that vehicle. In some states and provinces, operating such communications devices while in control of a vehicle is an offence.

Warning: *EXPLOSION HAZARD—DO NOT DISCONNECT WHILE CIRCUIT IS LIVE UNLESS THE AREA IS KNOWN TO BE NON-HAZARDOUS.*

Warning: *DO NOT USE THE USB CONNECTOR IN A HAZARDOUS AREA.*

Warning: *DO NOT USE THE RESET BUTTON IN A HAZARDOUS AREA.*

This device is suitable for use in Class 1 Div 2 Groups A, B, C, and D T4 locations. Ambient temperatures of -30C to +65C. UL Listed for use in ambient temperatures not exceeding 65C.

Warning: *Explosion Hazard. Do not connect or disconnect while circuit is live or unless the area is known to be free of ignitable concentrations.*

Avertissement: *RISQUE D'EXPLOSION—NE PAS DEBRANCHER TANT QUE LE CIRCUIT EST SOUS TENSION, A MOINS QU'IL NE S'AGISSE D'UN EMPLACEMENT NON DANGEREUX.*

Avertissement: *NE PAS UTILISER DE CONNECTEUR USB DANS LES ENVIRONNEMENTS DANGEREUX.*

Avertissement: *NE PAS UTILISER LE BOUTON DE RESET DANS UN ENVIRONNEMENT DANGEREUX.*

Cet appareil est certifié pour l'usage dans la Classe I, des endroits Division 2, Groupes atmosphérique A, B, C et de D, T4. La temp ambiante -30C à +65C. UL Listed pour utilisation dans des températures ambiantes ne dépassant pas 65C.

Avertissement : *Risque D'Explosion. Ne pas débrancher tant que le circuit est électrifié sauf si il n'y a aucune concentration de vapeurs combustible.*

The device is required to be installed in a tool-secured enclosure with the appropriate type rating.

Important Notice

Information relating to this product and the application or design described herein is believed to be reliable, however such information is provided as a guide only and Semtech assumes no liability for any errors in this document, or for the application or design described herein.

Semtech reserves the right to make changes to the product or this document at any time without notice. Buyers should obtain the latest relevant information before placing orders and should verify that such information is current and complete. Semtech warrants performance of its products to the specifications applicable at the time of sale, and all sales are made in accordance with Semtech's standard terms and conditions of sale.

SEMTECH PRODUCTS ARE NOT DESIGNED, INTENDED, AUTHORIZED OR WARRANTED TO BE SUITABLE FOR USE IN LIFE-SUPPORT APPLICATIONS, DEVICES OR SYSTEMS, OR IN NUCLEAR APPLICATIONS IN WHICH THE FAILURE COULD BE REASONABLY EXPECTED TO RESULT IN PERSONAL INJURY, LOSS OF LIFE OR SEVERE PROPERTY OR ENVIRONMENTAL DAMAGE. INCLUSION OF SEMTECH PRODUCTS IN SUCH APPLICATIONS IS UNDERSTOOD TO BE UNDERTAKEN SOLELY AT THE CUSTOMER'S OWN RISK. Should a customer purchase or use Semtech products for any such unauthorized application, the customer shall indemnify and hold Semtech and its officers, employees, subsidiaries, affiliates, and distributors harmless against all claims, costs damages and attorney fees which could arise.

The Semtech name and logo are registered trademarks of the Semtech Corporation. All other trademarks and trade names mentioned may be marks and names of Semtech or their respective companies. Semtech reserves the right to make changes to, or discontinue any products described in this document without further notice. Semtech makes no warranty, representation or guarantee, express or implied, regarding the suitability of its products for any particular purpose. All rights reserved.

Wireless Communications

Due to the nature of wireless communications, transmission and reception of data can never be guaranteed. Data may be delayed, corrupted (i.e., have errors) or be totally lost. The Semtech product should not be used in situations where failure to transmit or receive data could result in damage of any kind to the user or any other party, including but not limited to personal injury, death, or loss of property. Semtech accepts no responsibility for damages of any kind resulting from delays or errors in data transmitted or received using the Semtech product, or for failure of the Semtech product to transmit or receive such data.

Warranty

Warranty information for AirLink products is available at www.sierrawireless.com/end-user-warranty.

Sierra Wireless

Semtech Corporation purchased Sierra Wireless in January 2023. The Sierra Wireless brand is gradually being phased out. During the phase-out period, references to both "Semtech" and "Sierra Wireless" may appear in product documentation.

Patents

This product may contain technology developed by or for Sierra Wireless Inc. This product includes technology licensed from QUALCOMM®. This product is manufactured or sold by Sierra Wireless Inc. or its affiliates under one or more patents licensed from MMP Portfolio Licensing.

Copyright

© 2025 Semtech. All rights reserved.

Trademarks

Semtech[®], AirPrime[®], AirLink[®], AirVantage[®] and the Semtech logo are registered trademarks of Semtech.

Windows[®] and Windows Vista[®] are registered trademarks of Microsoft Corporation.

Macintosh[®] and Mac OS X[®] are registered trademarks of Apple Inc., registered in the U.S. and other countries.

QUALCOMM[®] is a registered trademark of QUALCOMM Incorporated. Used under license.

Other trademarks are the property of their respective owners.

Contact Information

Sales information and technical support, including warranty and returns	Web: sierrawireless.com/company/contact-us/ Global toll-free number: 1-877-687-7795 6:00 am to 5:00 pm PST
Corporate and product information	Web: sierrawireless.com

Contents

Safety and Hazards	2
Important Notice	2
Wireless Communications.....	3
Warranty.....	3
Sierra Wireless	3
Introduction to the LX60	8
Key Features	8
Description.....	9
Sample Power Consumption Scenarios.....	10
Accessories	11
Warranty.....	11
Installation and Startup	12
Tools and Materials Required.....	12
Installation Overview	12
Step 1 — Insert the SIM Card	13
Step 2 — Mount and Ground the LX60 Chassis	14
Step 3 — Connect the Antennas	15
Recommended Antenna Separation	16
Step 4 — Connect the Data Cables	16
Step 5 — Connect the Power	16
Cable Strain Relief	17
Fusing	17
DC Voltage Transients	17
Power Connector on the LX60	18
Wiring Diagrams	18
Vehicle Installation Considerations	20
Step 6 (Optional) — Connect the Vehicle Bus Cable.....	22
Step 7 — I/O and RS485 Configuration	23
I/O Pins	23

Step 8— Check the Router Operation	30
LED Behavior	31
Ethernet LEDs	32
Step 9— Configure the Software	33
Reboot the LX60.....	34
Reset the LX60 to Factory Default Settings.....	35
Recovery Mode.....	35
Specifications	37
Certification and Interoperability.....	37
Included Radio Module Firmware	37
Network Technology.....	38
Reliability	38
Environmental Testing.....	39
Host Interfaces.....	40
SIM Card Interface	42
Mechanical Specifications	42
Screw Torque Settings	42
Operating Voltage	42
Power Specifications	43
GNSS Technology.....	44
Protocols.....	44
Wi-Fi Performance	45
Wi-Fi Channels Supported.....	45
Wi-Fi Antenna Gain	46
Radio Frequency Bands	47
Radio Module Conducted Transmit Power.....	52
GNSS Bands supported	54
Mechanical Specifications	55

Regulatory Information	56
Important Information for North American Users	56
RF Exposure	57
Accessories	60
DC Power Cable (Black Connector)	60
AC Power Adapter (Black Connector)	61
AC Power Adapter Input	61
AC Power Adapter Output	61
AC Power Adapter Environmental Specifications	62
AC Power Adapter Reliability and Quality Control	62
AC Power Adapter Safety Standards	62
AC Power Adapter EMC Standards	62
AC Power Adapter Hazardous Substances	63
AC Power Adapter Energy Efficiency	63
I/O Connector Cable	64
Vehicle Bus Cables	65
I/O Cable	66
Index	67

1: Introduction to the LX60

This hardware user guide is for the Semtech® AirLink® LX60 LTE Router. Features and specifications described in this user guide apply to all variants of the LX60 unless otherwise noted.

The AirLink LX60 is designed for Commercial and Enterprise LTE network connectivity. Dual Gigabit Ethernet and serial ports make it ideal to connect machines and provide primary or backup network connectivity.

LX60 provides purpose-built, secure, reliable, managed Cellular LTE networking in building automation, digital signage, taxis, ATMs, kiosks and point-of-sale terminals.

As part of the AirLink Essential series, the LX60 is designed to meet the environmental and performance requirements of these applications, while delivering superior reliability and uninterrupted operation in fixed, indoor and protected outdoor environments.

LX60 is available with optional Wi-Fi + GNSS and rated for shock, vibration and vehicle power supplies. It offers Dual Band 802.11ac Wi-Fi and dedicated 48 Channel GNSS, meeting the demands of commercial fleets and taxis requiring connectivity.

The LX60 comes in LTE Cat 4 regional variants, and a Global LPWA (Low-Power Wide Area) variant offering LTE-M/NB-IoT for applications where low data rates, enhanced cellular coverage and global deployment is required.

Key Features

- LTE Cat-4 and Cat-M1/NB1 (LX60 variants)
- 2.4/5 GHz 802.11ac Wi-Fi (Wi-Fi + GNSS models only)
- 48 channel dedicated GNSS (Wi-Fi + GNSS models only)
- 2 Gigabit Ethernet ports (LAN/WAN)
- 5 configurable GPIOs
- Direct vehicle bus interface (OBD-II/J1939) (Wi-Fi + GNSS models only)
- RS232 and RS485

For information on configuring these features, refer to the [ALEOS Software Configuration User Guide](#).

Description

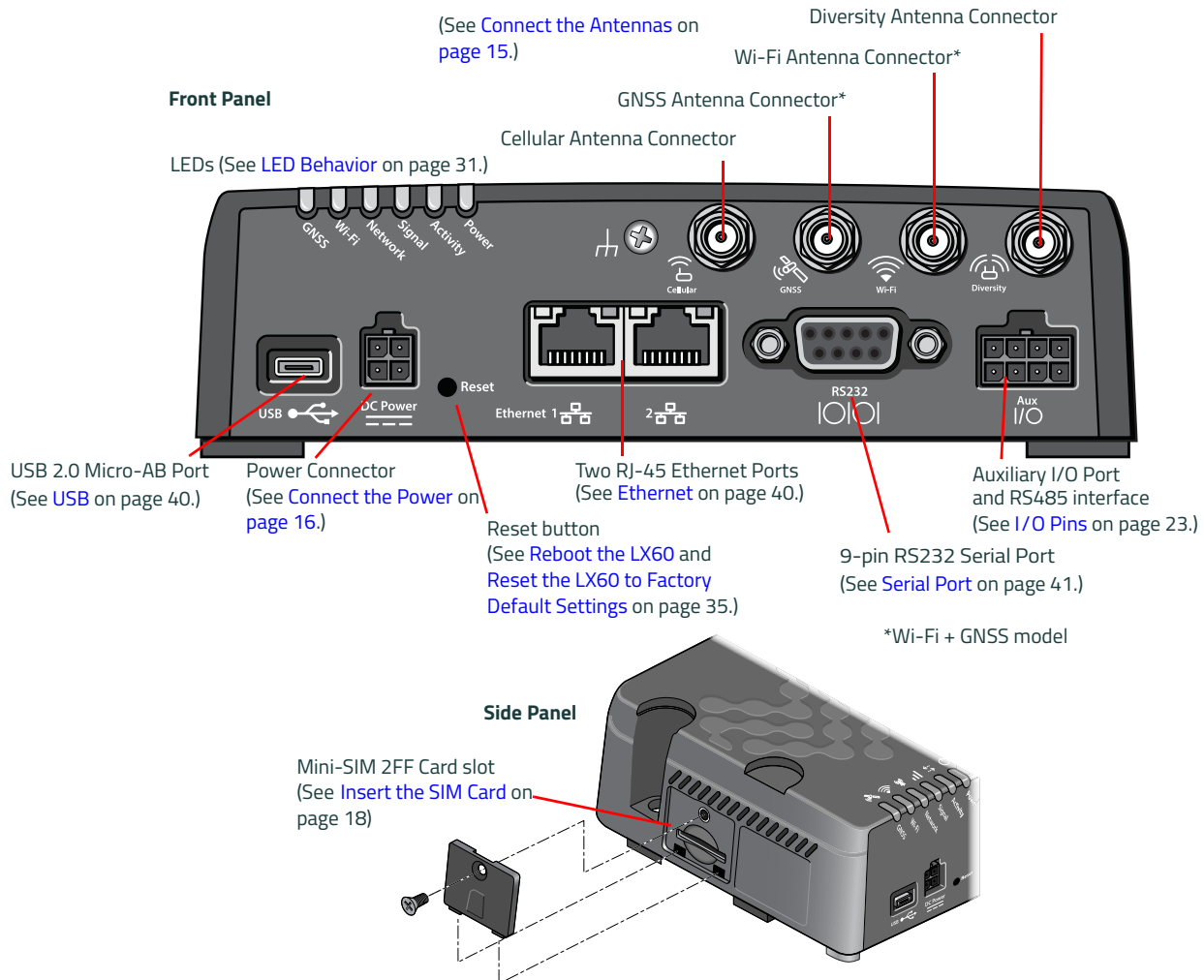

Figure 1-1: LX60 Connectors, LEDs and SIM Card Holder

Sample Power Consumption Scenarios

Table 1-1: Power Consumption Scenarios

Scenario	Radio	Notes	LTE Power ^a	Cat-M Power
Standby Mode	—	—	35 mW (2.9 mA)	35 mW (2.9 mA)
Serial	Idle Attached	Serial enabled	800 mW (66.6 mA)	800 mW (66.6 mA)
Ethernet 2x (10 BaseT)	Idle Attached	10 BaseT Full duplex	900 mW (75 mA)	900 mW (75 mA)
Ethernet 2x (100 BaseT)	Idle Attached	100 BaseT Full duplex	1100 mW (91.6 mA)	1100 mW (91.6 mA)
Ethernet 2x (GigE)	Idle Attached	1000 BaseT Full duplex	1700 mW (141.6 mA)	1700 mW (141.6 mA)
Wi-Fi AP 5GHz	Idle Attached	Wi-Fi enabled (idle)	1100 mW (91.6 mA)	n/a
Wi-Fi AP 5GHz + GNSS	Idle Attached	GNSS and Wi-Fi enabled (idle)	1300 mW (108.3 mA)	n/a
Typical Use (non- Wi-Fi)	Attached and connected (20 dBm)	100 BaseT Full duplex, Serial and USB enabled (idle)	4100 mW (341.6 mA)	2400 mW (200 mA)
Typical Use (Wi-Fi)	Attached and connected (20 dBm)	100 BaseT Full duplex, Serial, USB, and Wi-Fi enabled (idle), GNSS active	4400 mW (366.6 mA)	n/a
Maximum Power (non-Wi-Fi)	Attached and connected (23 dBm)	Ethernet enabled (Iperf running with Auto negotiation as speed setting), Serial enabled (recurring command), USB enabled (pinging)	6600 mW (550 mA)	5937 mW (495 mA)
Maximum Power (Wi-Fi)	Attached and connected (23 dBm)	Ethernet enabled (Iperf running with Auto negotiation as speed setting), Serial and GNSS enabled (recurring command), USB enabled (pinging), Wi-Fi enabled (Iperf running)	7000 mW (583.3 mA)	n/a
Inrush Current	1.5 A @ 12 V (Averaged over 100 μs)			

a. Power consumption was measured at 12 V.

Accessories

The following items come with the LX60 router:

- DC power cable
- Quick Start Guide

The following items can be ordered separately from Semtech:

- Universal AC power adapter
 - Voltage input: 100–240 VAC
 - Current output: 1.5 A
 - Part number: 2000579
- I/O Auxiliary cable
 - Part number: 6001004
- Vehicle Bus cable
 - OBD-II part number: 6001153
 - J1939 part number: 6001154

Warranty

You can download the LX60 router warranty from [the Semtech Source](#). Click **sign up** to register for free.

2: Installation and Startup

This chapter shows how to connect, install and start the AirLink LX60. It also describes the front panel LEDs, and I/O functionality.

Note: Field wiring and connections in hazardous locations must be connected as per the wiring methods requirement for Class 2 circuits mentioned in the National Electric Code and the Canadian Electric Code.

Note: The LX60 Series router installation must be done by a qualified technician.

Tools and Materials Required

- Power supply — AC or DC (DC power cable is supplied by Semtech)
- A SIM card (provided by your mobile network operator)
- #1 Phillips screwdriver
- Laptop computer with Ethernet cable
- LTE MIMO antennas — Main and Diversity
- Optional:
 - GNSS antenna¹
 - Wi-Fi antenna¹
 - 9-pin connection cable for the RS232 port
 - 8-pin auxiliary I/O connector cable
 - OBD-II or J1939 vehicle bus cable

Installation Overview

The steps for a typical installation are:

1. Insert the SIM card(s) — [page 13](#).
2. Mount and ground the LX60 chassis — [page 14](#).
3. Connect the antennas — [page 15](#).
4. Connect the data cables — [page 16](#).
5. Connect the power — [page 16](#).
6. (Optional) Connect the Vehicle Bus Cable — [page 22](#)
7. Check the router operation — [page 30](#).
8. Configure the software — [page 33](#).

The following sections describe these steps in detail. Read these sections carefully before performing the installation.

1. Applies only to the LX60 Wi-Fi + GNSS model

Warning: The default ACEmanager password is printed on the device label. You should always change the default password after logging in to ACEmanager. However, if the unit must be reset to factory default settings, your custom password may also be reset to default (depending on the Reset Mode configured in ACEmanager). Before installation, please record the default password and store it in a secure place. See also [Reset the LX60 to Factory Default Settings](#) on page 35.

Avertissement : Le mot de passe de ACEmanager est imprimé sur l'étiquette de l'unité. Nous vous recommandons fortement de le changer dès que possible (option dans AceManager). Notez que si l'unité est réinitialisée aux paramètres d'usine, le mot de passe pourrait également être réinitialisé à sa valeur d'origine (selon le mode de réinitialisation configuré dans ACEmanager). A cet effet, nous vous recommandons de noter ce mot de passe et de le garder dans un endroit sûr avant de déployer la dite unité. Pour plus d'information, veuillez consulter [page 35](#) ' Réinitialiser le LX60 aux paramètres d'usine par défaut '

Note: Depending on where you are installing the LX60, you may want to mount the router before connecting the antenna, cables and power.

Step 1 — Insert the SIM Card

If the SIM card has not already been installed, insert the SIM card into the router before connecting any external equipment or power to the router.

To install the SIM card:

1. Use a #1 Phillips screwdriver to remove the SIM card cover.
2. Orient the SIM card as shown in [Figure 2-1](#) (with the gold contacts facing down).
3. Gently slide the SIM card into the slot until it clicks into place.
To remove the SIM card, press the SIM card in, and release it. Gently grip the SIM card and pull it out.
4. Replace the SIM card cover. Tighten the screw to approximately 1.3 in-lb (1.5 cm-kg).

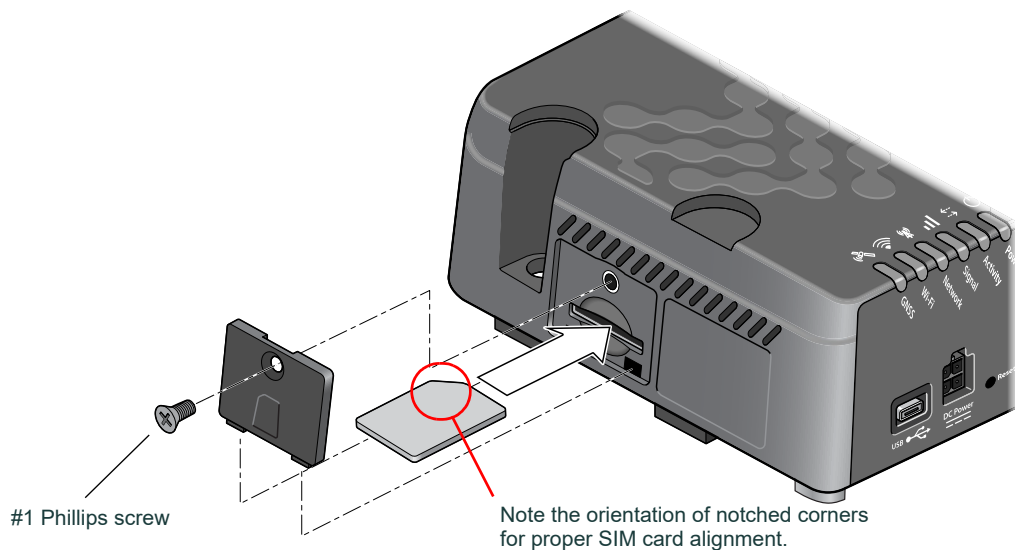

Figure 2-1: Installing the SIM Card

Step 2 — Mount and Ground the LX60 Chassis

Semtech strongly recommends that you always ground the chassis using the grounding point shown in [Figure 2-3](#).

Mount the router where:

- There is easy access for attaching the cables
- Cables will not be constricted, close to high amperages or exposed to extreme temperatures
- The front panel LEDs are easily visible
- There is adequate airflow
- It is away from direct exposure to the elements, such as sun, rain, dust, etc.

The LX60 has two mounting holes, as shown in [Figure 2-2](#). Use appropriate mounting screws to secure it in place.

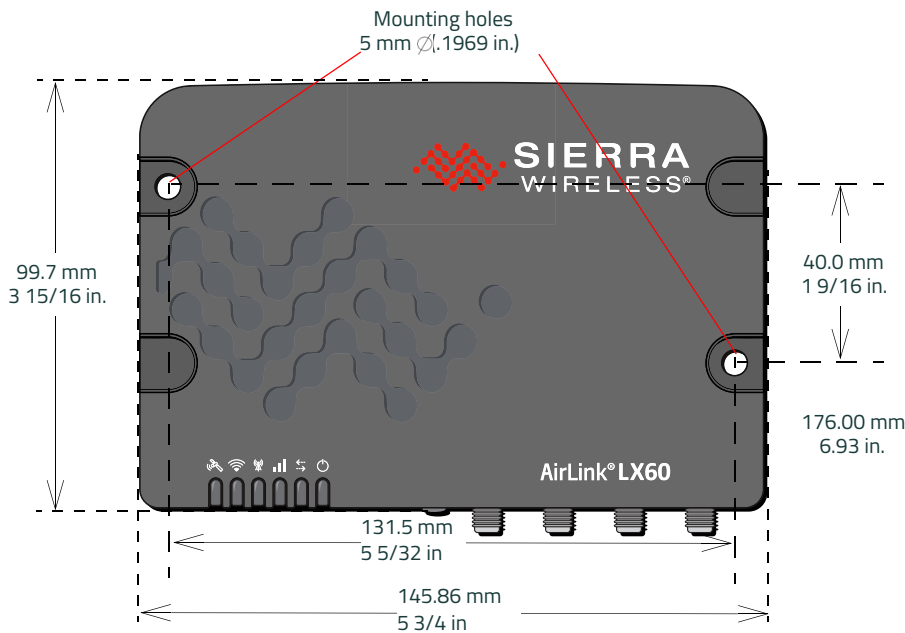

Figure 2-2: Mounting and Grounding the LX60

For DC installations (with a fixed “system” ground reference), Semtech recommends grounding the LX60 chassis to this system ground reference.

A ground wire is supplied with the unit. When using a different ground wire, to ensure a good grounding reference, connect one end of a short 18 AWG or larger gauge wire with a ring terminal connector to the ground terminal on the LX60 and connect the other end to your main grounding point.

The ground terminal comes with an M2.5 × 6 mm screw. You can use a longer M2.5 screw if the terminal connector on your ground wire requires one. Tighten the grounding screw to approximately 3.5 in-lb (4 cm-kg).

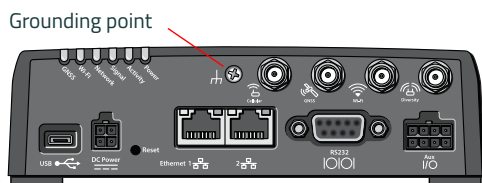

Figure 2-3: Ground connector

Step 3 — Connect the Antennas

Warning: *This router is not intended for use close to the human body. Antennas should be at least 8 inches (20 cm) away from the operator.*

Avertissement : *Ce routeur n'est pas destiné à être utilisé à proximité du corps humain. Les antennes doivent être à au moins 20 cm de toute personne.*

The LX60 has two SMA female antenna connectors:

- Cellular antenna connector: Primary receive and transmit antenna connector
- Cellular Diversity antenna connector: LTE MIMO and 3G Diversity

The AirLink LX60 with Wi-Fi + GNSS also has:

- One GNSS antenna connector
- One reverse polarity SMA male connector for the Wi-Fi antenna.
Semtech recommends cabling out the antenna.
The LX60 supports 2.4 GHz (2400–2500 MHz) and 5GHz (4900–5900 MHz) Wi-Fi bands.

For regulatory requirements concerning antennas, see [Maximum Antenna Gain](#) on page 57.

Note: The antenna should not exceed the maximum gain specified in [RF Exposure](#) on page 57. In more complex installations (such as those requiring long lengths of cable and/or multiple connections), you must follow the maximum dBi gain guidelines specified by the radio communications regulations of the Federal Communications Commission (FCC), Industry Canada, or your country's regulatory body.

To install the antennas:

Note: Take extra care when attaching the antennas to the SMA connectors. Finger tight (approximately 0.6–0.8 Nm 5–7 in-lb.) is sufficient and the max torque should not go beyond 1.1 Nm (10 in-lb.).

1. Connect the cellular antenna to the SMA cellular antenna connector.
Mount the cellular antenna so there is at least 20 cm between the antenna and the user or bystander.
 2. Connect a second antenna to the SMA diversity antenna connector.
For 3G networks, the second antenna operates as a diversity antenna, providing a second receive path.
For 4G networks, the second antenna operates as a MIMO antenna, providing a second receive path and a second transmit path.
 3. If used, connect a GNSS antenna to the SMA GNSS antenna connector.
Mount the GNSS antenna where it has a good view of the sky (at least 90°).
 4. For Wi-Fi-capable routers, connect the Wi-Fi antenna to the SMA Wi-Fi connector.
-

Note: If the antennas are located away from the router, keep the cables as short as possible to prevent the loss of antenna gain. Route the cables so that they are protected from damage and will not be snagged or pulled on. There should be no binding or sharp corners in the cable routing. Excess cabling should be bundled and tied off. Make sure the cables are secured so their weight will not loosen the connectors from the router over time. In vehicle installations, separate antenna, data, and power cables from other wiring.

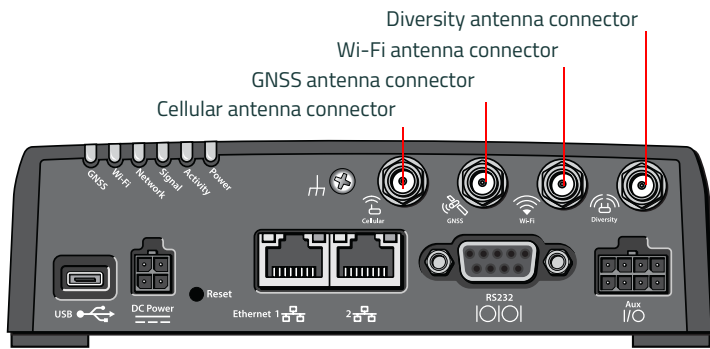

Figure 2-4: Antenna Connectors

Recommended Antenna Separation

The recommended antenna separation is related to the band frequency/wavelength. To accommodate the shortest frequency/longest wavelength band supported by the LX60, Semtech recommends a minimum antenna separation of 214 mm for best results, and if necessary, a separation of 107 mm for acceptable results.

Table 2-1: Frequency / Wavelength Range and Recommended Antenna Separation for the AirLink LX60

Service	Wavelength Range for LX60	Frequency (MHz)	Wavelength (λ) (mm)	Best Antenna Separation (mm) ($1/2 \lambda$)	Good Antenna Separation (mm) ($1/4 \lambda$)
LTE	Longest λ	700	428	214	107
LTE	Shortest λ	2600	115	58	29

Step 4 — Connect the Data Cables

The LX60 has the following ports for connecting data cables:

- **USB** (Micro-AB)
- **2 × Ethernet** (RJ-45) — Use a Cat 5e or Cat 6 Ethernet cable
- **Serial Port** (9-pin RS232)
- **Aux I/O Port** (2-pin RS485)

Note: In vehicle installations, separate antenna, data, and power cables from other wiring.

Step 5 — Connect the Power

The AirLink LX60 comes with a 3 meter (10 ft.) DC power cable. You can also purchase an optional AC adapter.

Warning: *Electrical installations are potentially dangerous and should be performed by personnel thoroughly trained in safe electrical wiring procedures.*

Avertissement : *Les installations électriques sont potentiellement dangereuses et devraient être effectuées par du personnel parfaitement formé aux procédures de sécurité de câblage électrique.*

The LX60 supports an operating voltage of 7 V – 36 V, but because low voltage standby mode is enabled by default, you must supply more than 9 V at startup.

If you want to operate the router at a lower voltage, you can change the low voltage standby settings once the router is up and running. For more information, refer to the [ALEOS Software Configuration User Guide](#) (Services chapter).

Cable Strain Relief

Semtech recommends using cable strain relief for installations in high-vibration environments.

Place the cable strain relief within 200 mm (8 in.) of the LX60 to reduce the mass of cable supported by the power connector under vibration. Ideally, the strain relief mounting for the DC cable should be attached to the same object as the LX60, so both the router and cable vibrate together. The strain relief should be mounted such that it does not apply additional stress on the power connector. The cable should not be taut and should not pull the power connector at an angle.

Fusing

For DC installations, Semtech recommends fusing the power input using a 4 A, fast blow fuse on the V_{in} line, recommended to have no more than $\pm 10\%$ de-rating over the operating temperature range.

DC Voltage Transients

The AirLink LX60 has built-in protection against vehicle transients including engine cranking (down to 5.0 V) and suppressed 12 V load dump, so there is no need for external power conditioning circuits. For details, see [Industry Certification for Vehicles](#) on page 37.

Power Connector on the LX60

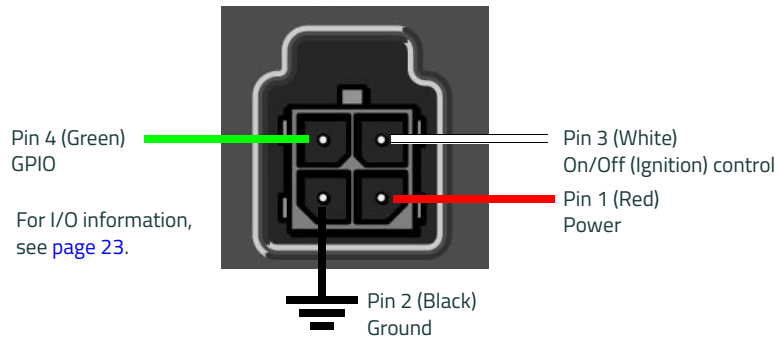

For more information, see wiring diagrams on [page 18](#).

Figure 2-5: DC Power Cable Connections (Colors indicate DC cable wire colors)

Table 2-2: Power Connector Pin and DC Cable Wires

Pin	Name	DC Cable Wire Color	Description	Type
1	Power	Red	Main power supply for device <i>Note: If you want to turn the LX60 on/off using a control line, such as a vehicle ignition line, Semtech strongly recommends that you connect the control/ignition line to Pin 3 and apply continuous power on Pin 1.</i>	PWR
2	Ground	Black	Main device ground	PWR
3	On/Off control	White	For installations where the LX60 is to be turned on/off, use the white wire connected to Pin 3 in the DC cable. The LX60 is off when this pin is either open-circuit or grounded, and on when this pin is connected to power. The LX60 should not be turned off by simply disconnecting the power. Pin 3 can be connected to the vehicle ignition or to an external switch. <i>Note: If you do not connect pin 3 to the ignition or other switch, you MUST connect it to the positive terminal of your power supply or battery. If you are using a Semtech AC adapter, the connection is inside the cable.</i>	I
4	GPIO	Green	User configurable digital input/output or analog voltage sensing input. Connect to switch, relay or external device. For more information, see Step 7 — I/O and RS485 Configuration on page 23 and refer to the ALEOS Software Configuration User Guide .	I/O

Wiring Diagrams

If you do not use the AC power adapter to power the LX60, you can wire the supplied DC cable to your power supply. You have various options for wiring power to the LX60, depending on your application.

Fixed Installation

For fixed installations, connect the wires as shown in the figure below. You can configure Low voltage disconnect to force the router into Standby mode when the voltage is low. Voltage is monitored on Pin 1 (red wire).

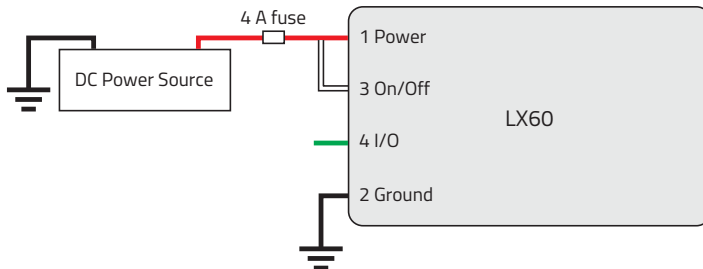

Figure 2-6: Fixed Installation without I/O

- Pin 1 (Power) — Use the red wire in the DC cable to connect Pin 1 to the power source. Include a 4 A, fast blow fuse, recommended to have no more than $\pm 10\%$ de-rating over the operating temperature range, in the input power line. Semtech recommends using a continuous (unswitched) DC power source.
- Pin 2 (Ground) — Use the black wire in the DC cable to connect Pin 2 to ground. See also [Step 2 — Mount and Ground the LX60 Chassis](#) on page 14.
- Pin 3 (On/Off control) — Connected to power

Fixed Installation with I/O Input Triggered by Standby Mode

If you have a fixed installation where you want to use the I/O to monitor an external device such as a motion detector, remote solar panel, or a remote camera, refer to [Figure 2-7](#). You can configure the I/O line to wake the router up for a configured length of time, and use low voltage disconnect to put the router in Standby mode if the voltage falls below a configured value.

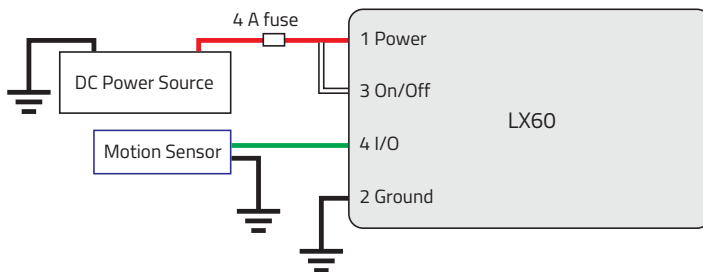

Figure 2-7: Fixed Installation with I/O

- Pin 1 (Power) — Use the red wire in the DC cable to connect Pin 1 to the power source. Include a 4 A, fast blow fuse, recommended to have no more than $\pm 10\%$ de-rating over the operating temperature range, in the input power line. Semtech recommends using a continuous (unswitched) DC power source.
- Pin 2 (Ground) — Use the black wire in the DC cable to connect Pin 2 to ground. See also [Step 2 — Mount and Ground the LX60 Chassis](#) on page 14.
- Pin 3 (On/Off control) — Connected to power
- Pin 4 (GPIO) — Use the green wire for I/O configurations. See [Step 7 — I/O and RS485 Configuration](#) on page 23.

Vehicle Installation Considerations

Connect the Router to the Vehicle's Electrical System

To connect the router to the vehicle's electrical system:

1. Ensure that the vehicle is turned off.
2. Remove the key from the ignition.
3. Disconnect the vehicle's battery:
 - a. Disconnect the negative terminal **first**.
 - b. Disconnect the positive terminal.
4. Connect the black (ground) wire on the DC power cable to the vehicle chassis.
5. Ensure that the LX60 is grounded. (See [Step 2 — Mount and Ground the LX60 Chassis](#) on page 14.)
6. Use a 4 A, fast blow fuse, recommended to have no more than $\pm 10\%$ de-rating over the operating temperature range, to connect the red (power) wire on the DC power cable to the vehicle's fuse box. (See [Figure 2-8](#).)
7. Connect the white wire (On/Off control) on the DC power cable to the ignition signal from the vehicle.
8. Connect the DC power cable to the LX60.
9. Reconnect the vehicle's battery:
 - a. Connect the positive terminal **first**.
 - b. Connect the negative terminal.

Vehicle Installation: Option 1

This vehicle installation allows the router to operate with the vehicle, in that when the vehicle ignition is off, the router is off. For vehicle installations, Semtech recommends connecting the white On/Off control wire to the vehicle's ignition switch, as shown in the following illustration.

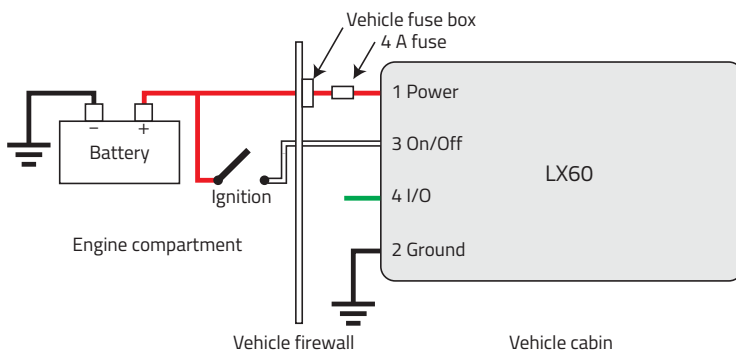

Figure 2-8: Vehicle Installation Option 1

If desired, you can configure a delay between the time the vehicle's ignition shuts off, and the time the router shuts down. A delayed shutdown is especially useful if you want to maintain a network connection while the vehicle's engine is shut off for short periods, such as in a delivery vehicle.

- Pin 1 (Power) — Use the red wire in the DC cable to connect Pin 1 to the power source. Include a 4 A, fast blow fuse, recommended to have no more than $\pm 10\%$ de-rating over the operating temperature range, in the input power line. Semtech recommends using a continuous (unswitched) DC power source. Connect the power through the vehicle's fuse box.

- Pin 2 (Ground)— Use the black wire in the DC cable to connect Pin 2 to ground. See also [Step 2 — Mount and Ground the LX60 Chassis](#) on page 14.
- Pin 3 (On/Off) — Semtech recommends always using the On/Off wire (Pin 3) to turn the router off. It should not be turned off by disconnecting the power.

Vehicle Installation: Option 2

The main difference between this installation and vehicle installation option 1 is that you can configure a timer to turn the router on at set intervals for a configured length of time; for example, 20 minutes once every 24 hours when the ignition is off. Also, instead of the router turning on and off, the router alternates between on and standby mode.

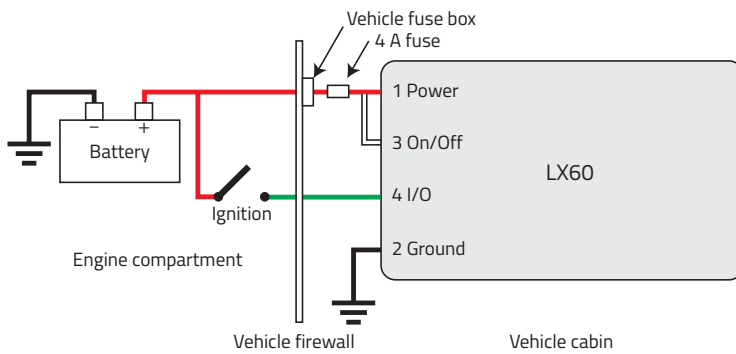

Figure 2-9: Alternate Vehicle Installation

- Pin 1 (Power) — Use the red wire in the DC cable to connect Pin 1 to the power source. Include a 4 A, fast blow fuse, recommended to have no more than $\pm 10\%$ de-rating over the operating temperature range, in the input power line. Semtech recommends using a continuous (unswitched) DC power source.
- Pin 2 (Ground) — Use the black wire in the DC cable to connect Pin 2 to ground. See also [Step 2 — Mount and Ground the LX60 Chassis](#) on page 14.
- Pin 3 (On/Off control) — Connected to power
- Pin 4 (I/O) — Connected to ignition

Step 6 (Optional) — Connect the Vehicle Bus Cable

The LX60 collects vehicle data through an OBD-II or J1939 connection from a vehicle's diagnostic port to the LX60 Aux I/O port. Accessory cables for either connection type are available separately from Semtech. See [Vehicle Bus Cables](#) on page 65.

After Vehicle Data Collection is enabled in ACEmanager, the router sends data to AirLink Mobility Manager (AMM 2.16 or later).

Note: Reporting of vehicle telemetry data from the direct vehicle connection to AirLink Management Service (ALMS) or 3rd party applications is supported in AVTA (AirLink Vehicle Telemetry Application version 1.1 or later). AVTA is an AAF application that is used to send telemetry data to a 3rd party server.

Note: An LX60 with Wi-Fi + GNSS running ALEOS 4.13.0 or later does not require a separate scanner for reporting of vehicle telemetry data (a Semtech AirLink Vehicle Telemetry kit, which includes an OBD-II scanner, is not required). Do not connect an additional scanner or other device to the vehicle bus during normal operation. When doing vehicle maintenance that requires connecting a diagnostic tool, it is recommended to disable the ALEOS setting Direct Vehicle Bus (CAN) Data Collection on the LX60.

To connect the LX60 with a vehicle bus cable:

1. Verify that the LX60 is running ALEOS Software Version 4.13.0 or later.
2. Ensure that both the LX60 and the vehicle are powered off.
3. Locate the OBD-II or J1939 port in the vehicle. The OBD-II port is an electrical socket most commonly located under the vehicle dashboard on the driver's side near the center console.
4. Attach the OBD-II or J1939 connector on the cable to the port in the vehicle.
5. Route the cable through the vehicle to where the LX60 is mounted.
6. Connect the 8-pin connector on the vehicle bus cable to the Auxiliary I/O port on the LX60.
7. Power on the router. Check that the Power, Signal, Network, and GNSS LEDs are lit as desired for your application (see [LED Behavior](#) on page 31).
8. Refer to the [ALEOS Software Configuration User Guide](#) for AirLink LX60. This guide describes how to configure the LX60 to enable accurate reporting of vehicle telemetry.

Note: Unlike the AirLink MP70, the LX60 does not support vehicle behavior reporting and dead reckoning.

Step 7 — I/O and RS485 Configuration

The AirLink LX60 has five pins you can use for I/O and RS485 configuration:

- Pin 4 on the power connector
- Pins 2, 3, 6, and 7 on the auxiliary I/O connector
 - Pins 2 and 6 are used for RS485 when RS485 is enabled

I/O Pins

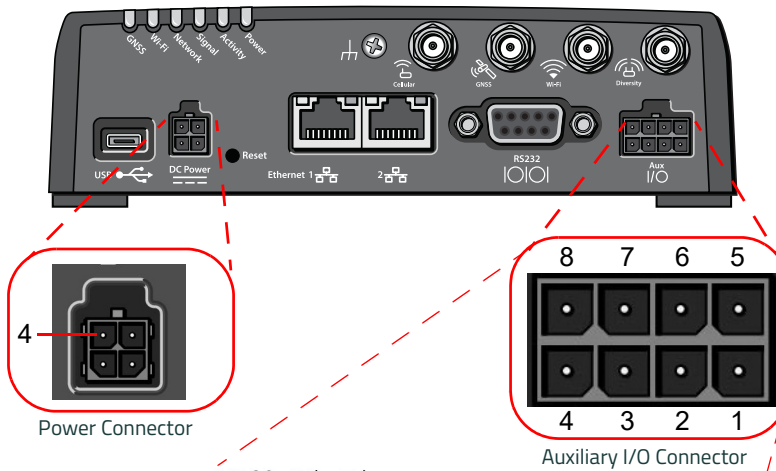

LX60 Wi-Fi

GND	Dig in 2 Analog 2	Dig in 3 Analog 3 RS485_A	CAN_L
8	7	6	5
CAN_H	Dig in 4	Dig in 5 RS485_B	GND
4	3	2	1

LX60

GND	Dig in 2 Analog 2	Dig in 3 Analog 3 RS485_A	N/U
8	7	6	5
N/U	Dig in 4	Dig in 5 RS485_B	GND
4	3	2	1

Figure 2-10: I/O Pin-out for Auxiliary I/O Connector and Power Connector

Table 2-3: I/O Pin-out Configuration

Location	Pin/Wire Color	Digital In	Analog In	Digital Out	Pull-up	RS485	GND	DO NOT Use	ACEmanager Configuration
Power Connector / DC Power Cable (included)	4/Green	✓	✓	✓	✓				Digital 1 Analog 1
Auxiliary I/O Connector / I/O Cable (SKU # 6001004)	6/Yellow	✓	✓		✓	✓			Digital 3 Analog 3 RS485 > Enable
	7/Gray	✓	✓		✓				Digital 2 Analog 2
	2/Orange	✓			✓	✓			Digital 5 RS485 > Enable
	3/Purple	✓			✓				Digital 4
	1/Black						✓		
	8/Black						✓		
	4/Reserved							✓	
	5/Reserved							✓	

You can use the I/O pins as:

- Pulse counters
(See [Table 2-4](#) on page 25 and [Figure 2-11](#) on page 25.)
- Digital inputs
(See [Table 2-4](#) on page 25 and [Figure 2-12](#) on page 26.)
- High side pull-ups/dry contact switch inputs
(See [Table 2-6](#) on page 27 and [Figure 2-13](#) on page 27.)
- Analog inputs
(See [Table 2-7](#) on page 28 and [Figure 2-14](#) on page 28.)
- Low side current sinks
(See [Table 2-8](#) on page 29 and [Figure 2-16](#) on page 29.)
- Digital outputs/open drains
(See [Table 2-9](#) on page 30 and [Figure 2-17](#) on page 30.)
- RS485 interface

Note: When RS485 is enabled, the other functions of I/O pins 2 and 6 (digital and analog inputs 3 and 5) are disabled. The disabled functions include pulse counting, analog input, digital inputs, and high-side pull-up/dry contact switch.

For more information, refer to the [ALEOS Software Configuration User Guide](#).

Note: The I/O pins can be configured in ACEmanager or ALMS to trigger standby mode, to sink current, or to pull up the voltage. If you are using the I/O line to trigger standby mode, you cannot configure it to sink current or pull up the voltage. Likewise, if you are using the I/O line to either sink current or pull up the voltage, you cannot use it to trigger standby mode.

Note: During bootup, the I/O settings remain in their default state: the internal pull-up resistor is disabled, and output current sink switch is open. After bootup, any custom I/O settings are applied. This may take approximately 30 seconds after the router is restarted or powered on.

You can use the I/O pins in conjunction with events reporting to configure the LX60 to send a report when the state of the monitored router changes, for example when a switch is opened or closed. For more information, refer to the [ALEOS Software Configuration User Guide](#) (Events Reporting chapter).

Pulse Counter

Pulse counter functionality is available on Pin 4 on the power connector and on Pins 2, 3, 6, and 7 on the auxiliary I/O connector.

You can connect any of these pins to a pulse counter. The digital pulse counter is not available in Standby mode.

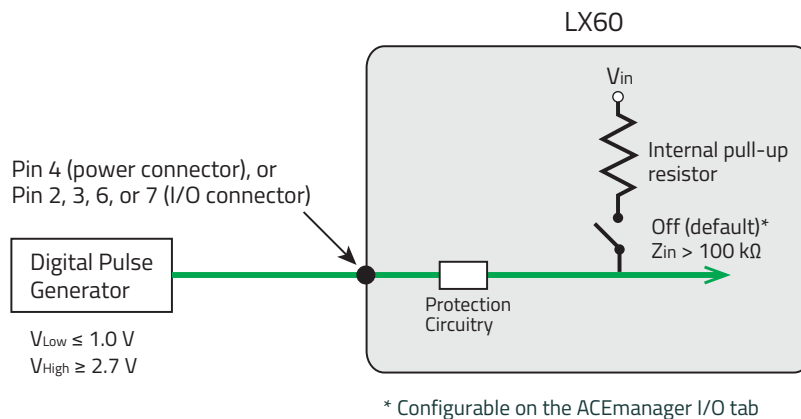

Figure 2-11: Digital Input / Pulse Counter

Maximum frequency: 140 Hz

Duty cycle: 20%–80%

Note: Values may vary, depending on signal noise.

Table 2-4: Pulse Counter

Pull-up	State	Minimum	Typical	Maximum
Off	Low	—	—	1.0 V
	High	2.7 V	—	V_{in}

Digital Input

Digital input is available on Pin 4 on the power connector and on Pins 2, 3, 6, and 7 on the auxiliary I/O connector.

You can connect any of these pins to a digital input to detect the state of a switch such as a vehicle ignition, or to monitor an external device such as a motion detector, a remote solar panel, or a remote camera. Digital input can also be used with the standby timer.

The primary digital input of Pin 4 on the power connector can be used to wake the router from standby. The four digital inputs on the I/O connector do not have this functionality.

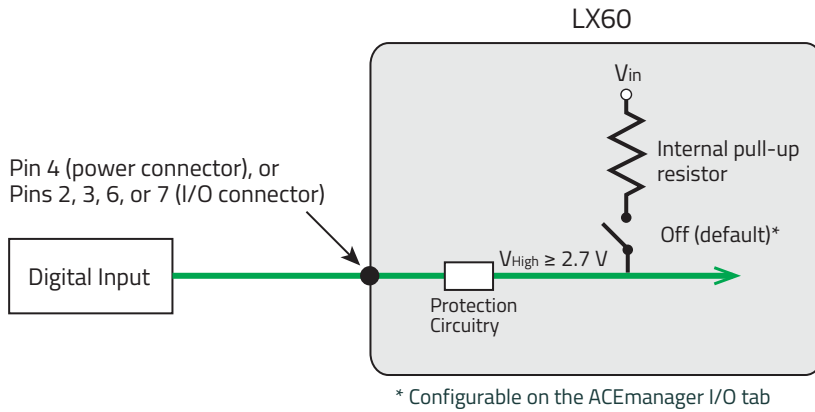

Figure 2-12: Digital Input

Table 2-5: Digital Input

Pull-up	State	Minimum	Typical	Maximum
Off	Low	—	—	1.0 V
	High	2.7 V	—	V_{in}

High Side Pull-up / Dry Contact Switch Input

High side pull-up / dry contact switch input is available on Pin 4 on the power connector and on Pins 2, 3, 6, and 7 on the auxiliary I/O connector.

You can connect any of these pins to a dry contact switch. The dry contact switch is not available in Standby mode.

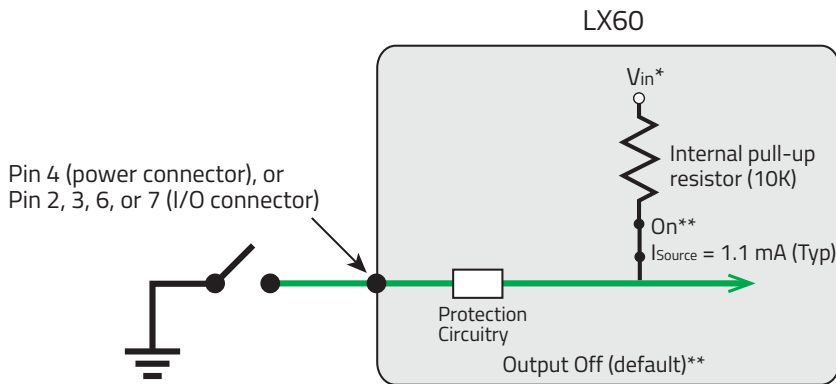

* Depending on the load, this value can range from V_{in} to $V_{in} - 2.5 V$.

** Configurable on the ACEmanager I/O tab

Figure 2-13: High Side Pull-up / Dry Contact Switch Input

Table 2-6: High Side Pull-up / Dry Contact Switch Input

	Minimum	Typical	Maximum	Comments
Source Current	0.6 mA $V_{in} = 7 V$	1.1 mA $V_{in} = 12 V$	3.5 mA $V_{in} = 36 V$	Maximum current the voltage output can provide (depends on V_{in})
V_{out}	$V_{in} - 2.5 V$	—	V_{in}	The voltage on Pin 4 when the high side pull-up is enabled (depends on V_{in} and power consumption)

Analog Input

You can connect Pin 4 on the power connector or Pins 6 or 7 on the auxiliary I/O connector to an analog sensor. As an analog input (voltage sensing pin), the router monitors voltage changes in small increments. This allows you to monitor equipment that reports status as an analog voltage.

The pin detects inputs of 0.5–5 V or 0.5–10 V referenced to ground. When used with a sensor to transform values into voltages, the pin can monitor measurements such as temperatures, sensors, or input voltage.

Using ACEmanager, you can select the range of voltage to be monitored to be 0–5 V or 0–10 V. For low input voltages, 0–5 V provides better accuracy.

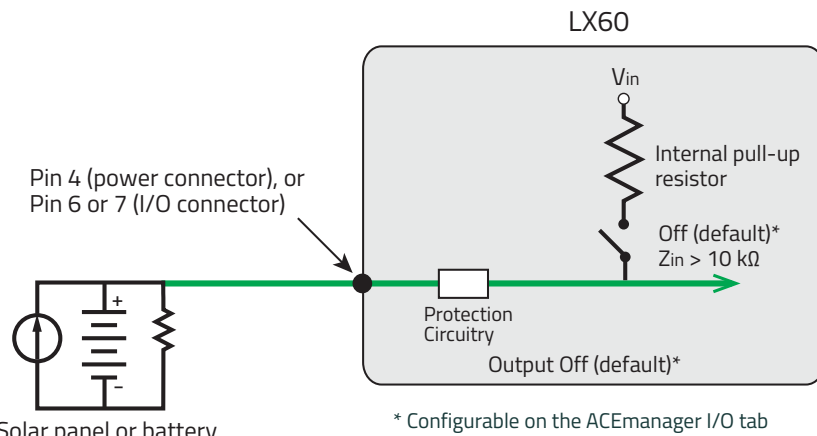

Figure 2-14: Analog Input

Table 2-7: Analog Input

Pull-up		Minimum	Typical	Maximum
Off	Analog Input Range	0.5 V	—	5 V, 10 V (configurable)
	Analog Input Accuracy	-1.5%	0.50%	1.5%

Data sampling is handled by a dedicated microprocessor. In order to filter noisy signals, twenty measurements are taken over a 250 ms interval. The measurements are averaged to generate a sample. If the change since the last sample is significant, a notification is sent to the CPU for updating the current value displayed in the user interface and for use by Events Reporting.

Changes are considered significant if the change is 200 mV or more (when the range of monitored voltage is 0–5 V) or 350 mV or more (when the range of monitored voltage is 0–10 V). If there has not been a significant change to the parameter being monitored, the CPU reads a sample every 2.5 minutes, which detects small changes.

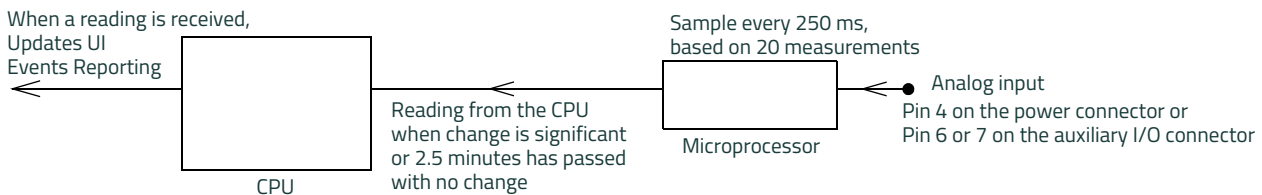

Figure 2-15: Analog Input Sampling and Reading

Note: The same method is used to sample the input voltage and the internal board temperature for Events Reporting. The significant changes are 300 mV for the input voltage and 1 °C for the board temperature.

Low Side Current Sink Output

Low side current sink output, for example to drive a relay, is only available using Pin 4 on the power connector.

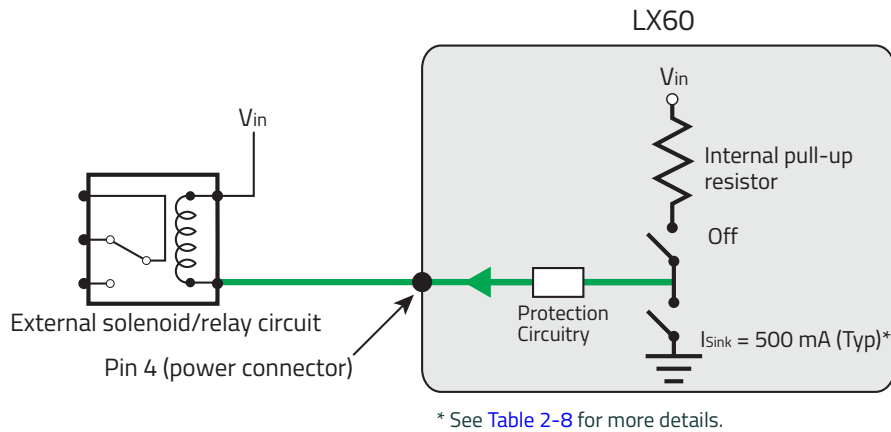

Figure 2-16: Low Side Current Sink

Table 2-8: Low Side Current Sink

Pull-up	State	Minimum	Typical	Maximum	Comments
Off	On	300 mA	500 mA	850 mA	I_Typical = 25°C I_Min = 65°C I_Max = -30°C
Off	Off	—	0 mA	—	V _{in} = 12

Note: The router protection circuitry has a high-impedance (~200 kΩ) path to ground. If Pin 4 is connected to 12 V, there will be a small current flow (~100 μA) into Pin 4 during bootup. This flow is countered when the internal pull-up resistor (10 kΩ) becomes active after bootup. Depending on your application, you may need to install an external pull-up resistor (10 kΩ) in order to nullify the small input current flow for the first 30 seconds during bootup.

Digital Output/Open Drain

Digital output/open drain, for example to drive an external digital input, is only available using Pin 4 on the power connector.

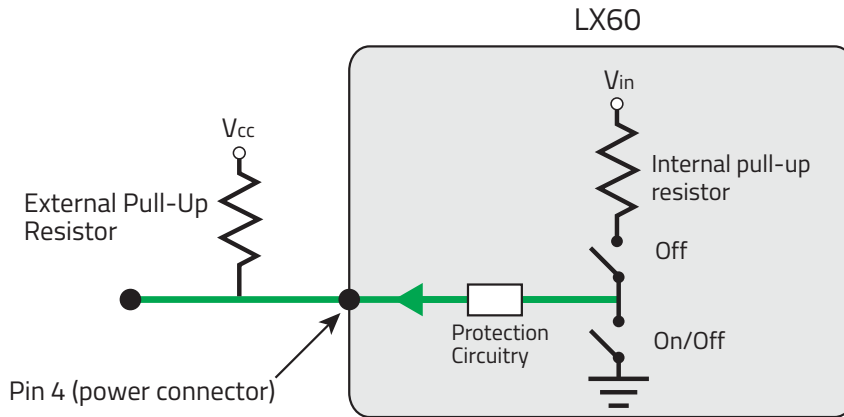

Figure 2-17: Digital Output/Open Drain

Table 2-9: Digital Output / Open Drain

Pull-up	State	Minimum	Typical	Maximum	Comments
Off	Off	Open Circuit	—	—	—
	Active Low	—	—	0.5 V	5 mA, ≤ 5 V

Step 8 — Check the Router Operation

- When power is supplied to the AirLink LX60 router, it powers up automatically, as indicated by the flashing LEDs. If it does not turn on, ensure that the:
 - Power connector is plugged in and supplying voltage greater than 9 VDC.

Note: Although the LX60 operates in the range 7–36 VDC, low voltage standby mode is enabled by default. In order to avoid the router powering on in standby mode, ensure that it is supplied with more than 9 VDC at startup. (You can change the low voltage standby mode settings once the router is operational. If the Power LED is red, the router is in standby mode.)

- On/Off control (pin 3) is connected to the battery or power source (see [Step 5 — Connect the Power](#) on page 16 for details).

LED Behavior

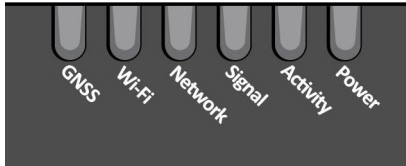

Table 2-10: LED Behavior

LED	Color / Pattern	Description
Power	Off	No power or input voltage ≥ 36 VDC or ≤ 7 VDC
	Solid Green	Power is present.
	Solid Red	Standby mode If you want to operate the router using less than 9 V, change the Low Voltage Standby settings (In ACEmanager, see Services > Power Management). <i>Note: You can configure the Power LED to flash slowly or turn off during Standby mode. In ACEmanager, see Services > Power Management.</i>
	Flashing Green	When you press the Reset button for less than 5 seconds, flashing green indicates when to release the reset button to reboot the router.
	Flashing Red	When you press the Reset button for 5 – 20 seconds, flashing red indicates when to release the Reset button to reset the router to the factory default settings.
	Flashing Amber	When you press the Reset button for more than 20 seconds, flashing amber indicates when to release the Reset button to enter Recovery mode. (See Recovery Mode on page 35.)
Activity	Flashing Green	Traffic is being transmitted or received over the WAN interface.
	Flashing Red	Traffic is being transmitted or received over the serial port. This behavior only appears if the LX60 is configured to display it. For more information, refer to the ALEOS Software Configuration Guide (Serial chapter).
	Flashing Amber	Traffic is being transmitted or received over both the WAN interface and the serial port. This behavior only appears if the LX60 is configured to display it. Refer to the ALEOS Software Configuration Guide (Serial chapter).
Signal	Solid Green	Good signal (equivalent to 3 – 5 bars)
	Solid Amber	Fair signal (equivalent to 2 bars)
	Flashing Amber	Poor signal (equivalent to 1 bar) Semtech recommends moving the router to a location with a better signal, if possible.
	Flashing Red	Inadequate (equivalent to 0 bars) Semtech recommends moving the router to a location with a better signal.

Note: The quality of the signal strength is measured using the appropriate parameters for the radio technology in use.

Table 2-10: LED Behavior

LED	Color / Pattern	Description
Network	Solid Green	Connected to an LTE network
	Solid Amber	Connected to a 3G or 2G network
	Flashing Green	Connecting to the network
	Flashing Red	No network available
	Flashing Red / Amber	Network Operator Switching is enabled, but the router is unable to locate the required firmware. For more information, refer to the ALEOS Software Configuration User Guide (Admin chapter).
Wi-Fi ^a	Off	Wi-Fi is disabled. (Configurable in ACEmanager and ALMS)
	Solid Green	Wi-Fi is enabled.
	Solid Amber	Wi-Fi is enabled, and the router is connected to an Access Point. (i.e. Wi-Fi is being used as the WAN connection)
	Flashing (Green or Amber)	Wi-Fi traffic is being sent or received.
GNSS ^b	Solid Green	The router has a GNSS fix.
	Flashing Green	No GNSS fix
	Off	GNSS is disabled. (Configurable in ACEmanager and ALMS)
ALL	Green LED chase	Radio module reconfiguration / firmware update or Network Operator Switching is in progress.
	Amber LED chase	ALEOS software update is in progress.
	Solid Amber	ALEOS software update complete
	Red LED chase	Recovery mode

a. LX60 Wi-Fi + GNSS only

Ethernet LEDs

The connector has two LEDs that indicate speed and activity. When looking into the connector:

- Activity—The right LED indicates the link status:
 - Solid—Link
 - Blinking Amber—Activity
 - Off—No link
- Connection Speed—The left LED indicates the Ethernet connection speed:
 - Solid Green—1000 Mbps (Gigabit)
 - Off—10/100 Mbps

Step 9 — Configure the Software

You can configure the ALEOS software on the LX60 using:

- [ACEmanager](#) (browser-based application)
- [AirLink Management Service](#) (cloud-based application)
- [AirLink Mobility Manager](#) (unified software platform deployed in the enterprise data center)
- [AT Commands](#)

Configuring with ACEmanager

To access ACEmanager:

1. Connect a laptop to the router with an Ethernet cable.
2. Launch your web browser and go to:
 - <https://192.168.13.31:9443> (ALEOS 4.14.0 and later)
 - <http://192.168.13.31:9191> (ALEOS 4.13.0 or previous)

Note: It takes the router from 1 to 2 minutes to respond after power up.

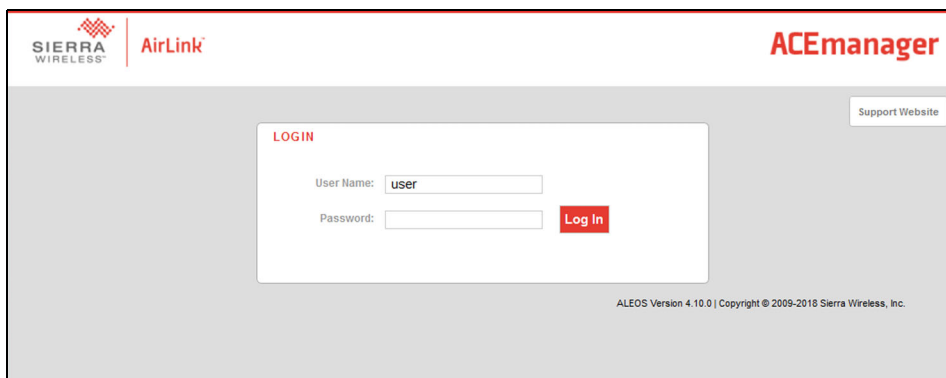

Figure 2-18: ACEmanager login window

3. Enter the default password (printed on the device label) and click Log In.

Note: For system security, ensure that you change the default password as soon as possible.

4. Refer to the [ALEOS Software Configuration User Guide](#) for information on how to use ACEmanager to configure your LX60.

Configuring with AirLink Management Service

AirLink Management Service (ALMS) allows remote management of all your routers from one user interface.

Some of its features include:

- Centralized, remote monitoring for all your AirLink routers
- Continuous status monitoring of important health data such as signal strength
- Location monitoring, including world map views
- Complete ALEOS reporting and configuration, including historical views of ALEOS information
- Configure individual routers or use templates to perform batch configurations of your AirLink routers

- Single-click over-the-air firmware updates to all your routers
- Compatible with all carriers or mobile network operators

To get started, either call your AirLink reseller or visit:

www.sierrawireless.com/ALMS

Configuring with AMM

AirLink Mobility Manager (AMM) is a Network Management solution that provides a consolidated view of the entire vehicle fleet and enables simplified management, control and monitoring of connected AirLink routers. AMM is a licensed, unified software platform deployed in the enterprise data center. It enables:

- Mobile network and asset management
- Over-the-air registration, configuration and software updates
- Consolidated network view of an entire fleet, in-field applications and mobile assets, using a virtual dashboard to monitor, report, manage, and troubleshoot all mobile resources as required.

If you require a network management solution deployed in your data center, contact your Semtech sales representative for a demonstration of the AMM capabilities.

Configuring with AT Commands

For a complete list of AT commands, refer to the [ALEOS Software Configuration User Guide](#).

Reboot the LX60

To reboot the LX60, either:

- On the router, use a tool such as a paper clip or small screwdriver to press the Reset button for less than 5 seconds. (Release the button when the Power LED flashes green.) The reset button is recessed approximately 5 mm (1/4 inch), which prevents casual use of a pen for resetting the router. The Reset button is small, so ensure that the tool fully contacts the button.
- In ACEmanager, click the Reboot button on the toolbar.

Reset the LX60 to Factory Default Settings

To reset the router to the factory default settings:

- In ACEmanager, go to Admin > Advanced and click the Reset to Factory Default button.

Note: When you use ACEmanager to reset the router to the factory default settings, some settings such the user password, network ID, network password, custom APNs, low voltage standby are preserved by default. However, you can configure the LX60 Reset Mode to reset all values, including the user password. For more details, refer to the [ALEOS Software Configuration User Guide](#) (Admin chapter).

–Or–

- On the router, press the Reset button for between 5 and 20 seconds. (Release the button when the Power LED flashes red.)
Once the LEDs resume their normal operating behavior, the reset is complete.

Warning: Using the Reset button as described above resets **all** settings to default, including the user password, no matter what Reset Mode you have configured in ACEmanager. The Reset button can be disabled in ACEmanager if required. Before installation, please record the default password on the device label and store it in a secure place.

Avertissement : L'utilisation du bouton comme décrit ci-dessus réinitialise tous les paramètres par défaut, y compris le mot de passe utilisateur, quel que soit le mode de réinitialisation que vous avez configuré dans ACEmanager. Ce bouton peut être désactivé dans ACEmanager si nécessaire. Avant déploiement de l'unité, veuillez enregistrer le mot de passe indiqué sur l'étiquette et le garder dans un endroit sûr.

Recovery Mode

If the router fails to boot properly, it automatically enters recovery mode, or, if the router is unresponsive to ACEmanager input and AT commands, you can manually put the router into recovery mode.

Recovery mode enables you to update the ALEOS software and return the router to working order. (For details, refer to the [ALEOS Software Configuration User Guide](#) — Configuring your router chapter.)

To enter Recovery mode manually:

- On the router, press the Reset button for more than 20 seconds. (Release the button when the Power LED flashes amber.)

To recover the router:

- Update ALEOS using the Recovery mode interface. Once the new ALEOS version is successfully uploaded and installed, the router reboots and exits recovery mode. When the process is complete, the ACEmanager login screen appears.

Note: After the recovery, you need to reload the radio module firmware store and templates.

To exit Recovery mode, if it has been inadvertently entered, do one of the following:

- Press the reset button on the router to reboot it.
- Click the Reboot button on the Recovery screen.

- Wait 10 minutes. If no action is taken within 10 minutes of the device entering Recovery mode (for example, if the Recovery screen has not been loaded by the web browser), it automatically reboots and exits Recovery mode.

For more information, refer to the [ALEOS Software Configuration User Guide](#) (Router Configuration chapter).

3: Specifications

This chapter describes the LX60 Series router specifications.

Certification and Interoperability

Note: All certifications listed below are pending. Some are in progress; others are planned.

Emissions / Immunity	<ul style="list-style-type: none"> ▪ FCC ▪ Industry Canada
Safety	<ul style="list-style-type: none"> ▪ CB Scheme ▪ UL 60950
Industry Certification for Vehicles	<ul style="list-style-type: none"> ▪ ISO7637-2 ▪ SAE J1455 (Shock & Vibration)
Environmental Compliance	<ul style="list-style-type: none"> ▪ RoHS 2011/65/EU (RoHS 2) ▪ WEEE ▪ REACH
GSM/HSPA+ Certifications	<ul style="list-style-type: none"> ▪ PTCRB ▪ GCF-CC ▪ RED

Included Radio Module Firmware

For carrier certification, please see the Tech Spec at sierrawireless.com.

LX60 LTE NA (Wi-Fi/GNSS/Telemetry):

- Sierra (default)
- AT&T
- Verizon
- Generic

LX60 LTE NA (Wi-Fi/GNSS):

- Generic (default)
- Sierra
- AT&T

LX60 LTE Verizon (Wi-Fi/GNSS):

- Verizon (default)

LX60 LTE EMEA:

- Sierra (default)
- Generic

LX60 LTE Australia/NZ:

- Generic (default)

- Telstra
- Sierra

LX60 LTE-M/NB-IoT Global:

- Generic (default)
- AT&T
- Verizon
- Sierra

Network Technology

LTE and HSPA

For a list of supported bands, see [Table 3-6](#) on page 47 and [Table 3-7](#) on page 47.

Reliability

MTBF calculations are performed per Telcordia “Reliability Prediction Procedure for Electronic Equipment” document number SR-332, Method I, Issue 3.

The MTBF for the LX60 (Ground Fixed, 25°C) is 327,289 hours (37.36 years).

Environmental Testing

Ingress protection rating is IP20.

Test Method	Category	Description
MIL-STD-810G, Test method 514.6	Vibration	Frequency range: 5 Hz–500 Hz Spectrum level: 2.24G on all axes for 8 hours/axis Operating mode: powered on
MIL-STD-810G, Test method 516.6, Procedure 1	Mechanical Shock	Half-sine 40G, 15–23 ms, (+/-X, +/-Y, +/-Z directions, 10 times per axis) Operating mode: powered on
MIL-STD-810G, Test methods 501.5, 502.5	Temperature	Rugged category: -30 °C to 65 °C 2-hour soak each temp high/low 3 cycles ramp <= 3 °C/minute Operating mode: powered on
MIL-STD-810G, Test methods 501.5, 502.5	Temperature	Rugged category: -40 °C to 85 °C 2-hour soak each temp high/low 50 cycles ramp <= 3 °C/minute Operating mode: unpowered
MIL-STD-810G, Test method 507.5	Humidity	10 × 48-hour cycles: <ul style="list-style-type: none"> ▪ Before starting cycles, condition to 23 °C and 50% relative humidity for 24 hours ▪ 2-hour ramp to 60 °C (90% humidity), hold 6 hours ▪ 8-hour ramp down to 30 °C (85% to 90% relative humidity), hold 8 hours ▪ After finishing cycles, condition to 23 °C and 50% relative humidity for one hour Operating mode: powered on
IEC 61000-4-2	Electrostatic Discharge	+/-2 kV, +/-4 kV, +/-6 kV, +/-8 kV (Contact and Air) +/-15 kV (Air at antenna connector) Operating mode: powered on
IEC 60068-2-32	Free Fall Test	1 m drop height 6 drops onto concrete, 2 per axis: X, Y, Z Operating mode: unpowered
IEC 60068-2-70 Part 2, Test Xb	Marking	The markings are rubbed with water for 10 cycles, then with lubricating oil for 10 cycles. Operating mode: unpowered
ISTA 2A 2001, test categories 1, 4, 5, & 6	Package	In shipping packaging. Cargo vibration and drop test.

Host Interfaces

<p>Antenna connectors</p>	<ul style="list-style-type: none"> ▪ On all units: <ul style="list-style-type: none"> • Cellular SMA • SMA Diversity ▪ On units with Wi-Fi + GNSS option: <ul style="list-style-type: none"> • Active GNSS SMA • One RP SMA Wi-Fi
<p>USB</p>	<hr/> <p><i>Note: Do not use the USB port in a potentially explosive environment.</i></p> <hr/> <ul style="list-style-type: none"> ▪ USB 2.0 Micro-AB connector complies with USB Version 2.0 for high speed operation ▪ Can be configured to operate in one of two modes: <ul style="list-style-type: none"> • Virtual Ethernet Port: The LX60 behaves as if the PC were connected to an Ethernet port, allowing access to the Internet and the LX60’s internal web server. This is the default setting. • Virtual Serial Port: The LX60 behaves as if it was connected to a standard serial port. The primary use of this interface is for the AT command line interface of ALEOS and for diagnostic access to the radio module. <p>By default, the USB port is configured as a virtual Ethernet port.</p> ▪ A Windows driver must be installed on the PC in order to support USB use. The drivers are available for download on Semtech’ support web site: source.sierrawireless.com/resources/airlink/software_downloads/airlink_usb_driver/ ▪ The ALEOS Software Configuration User Guide contains the details of USB mode configuration and driver installation. ▪ Semtech recommends you: <ul style="list-style-type: none"> • Use a USB 2.0 cable • Connect directly to your computer for best throughput.
<p>Ethernet</p>	<ul style="list-style-type: none"> ▪ 10/100/ 1000 Base-T RJ-45 Ethernet ▪ IEEE 802.3 Ethernet specification for 1000 Mbps speed (Gigabit Ethernet) with fallback to 100 or 10 Mbps (Cat 5e or Cat 6 cable is required for Gigabit Ethernet) ▪ Auto-crossover support ▪ Auto-negotiation detects the speed of the connecting device

Serial Port

- 9-pin RS232 serial port connects directly to most computers or other devices with a standard serial straight-through cable

Note: If you have a DCE device, you need to use a null modem (cross-over) cable.

- Used for connecting serial devices and configuration
- Complies with the EIA RS232D specification for DCE equipment
- Output driver levels swing from -7 VDC to +7 VDC with normal loading

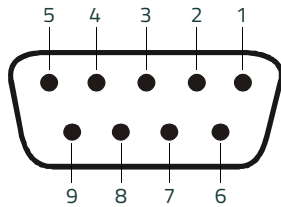

Figure 3-1: DB-9 Female Serial Connector

Table 3-1: Serial Connector Pin-out

Name	Pin	Description	Type
DCD	1	Data Carrier Detect	OUT
RXD	2	Receive Data	OUT
TXD	3	Transmit Data	IN
DTR	4	Data Terminal Ready	IN
GND	5	Main GND. Connected internally to BOARD GND	GND
DSR	6	Data Set Ready	OUT
RTS	7	Ready To Send	IN
CTS	8	Clear To Send	OUT
RI	9	Not connected	—

RS485

- Carried by Pins 2 and 6 of the I/O connector.
- RS485 is disabled by default
- Supports up to 115.2 Kbps (half-duplex)
- Default startup mode is Normal (AT command), with UDP PAD and TCP PAD modes available
- Termination resistor can be enabled/disabled in ACEmanager

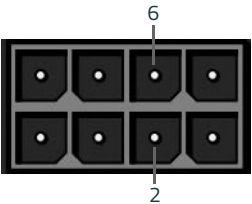

Figure 3-2: Aux I/O Port

Table 3-2: I/O Connector Pin-out for RS485

Name	Pin	Description
RS485_A	6	Non-inverting
RS485_B	2	Inverting

SIM Card Interface

- The LX60 has one 6-pin SIM socket for a mini-SIM (2FF) SIM card, operated at 1.8 V/3.3 V.
- This interface is compliant with the applicable 3GPP standards for USIM.

Mechanical Specifications

For mechanical drawings, dimensions, and weight, see [Mechanical Specifications](#) on page 55.

- Housing—The LX60 is made of rugged injection-molded plastic.
- RoHS2—The LX60 complies with the Restriction of Hazardous Substances Directive 2011/65/EU (RoHS2). This directive restricts the use of hazardous materials in the manufacture of various types of electronic and electrical equipment.

Screw Torque Settings

- Mount screws: 1.1 N-m (10 in-lb)
- Antennas: Finger tight (5–7 in-lb) is sufficient. The max torque should not go beyond 1.1 N-m (10 in-lb).

Operating Voltage

By default, the router is configured to enter Standby mode at 9 V. If you want to operate the router at less than 9 volts, power it on using at least 9 V, launch ACEmanager, go to Services > Power Management and adjust the Standby mode settings.

The maximum ripple voltage to guarantee analog input accuracy must be 100 mVpp.

Power Specifications

Table C-3: Power Supply Specifications

Pin	Name	Specification	Parameter	Minimum	Maximum
1	VCC	Voltage range	VCC	7 V	36 V

Table C-4: Ignition Sense Specifications

Pin	Name	Current Sink	Specification	Parameter	Minimum	Maximum
3	IS (Input only)	240 k Ω	Input low state voltage (maximum)	V_{IL}	—	1.0 V
			Input high state voltage (minimum guaranteed)	V_{IH}	2.5 V	V_{in}

*Note: If you do not connect this pin to the ignition, you **MUST** connect it to the positive terminal of your power supply or battery. The device looks for a qualified voltage on this pin as part of the power up sequence. If the device doesn't see it, the device will not turn on. If you are using a Semtech AC power adapter, the connection is inside the cable.*

GNSS Technology

Satellite channels	Maximum 48 tracking channels and 2 fast acquisition channels
Constellations	<ul style="list-style-type: none">▪ GPS▪ Galileo▪ GLONASS▪ BeiDou▪ QZSS
Protocol	NMEA 0183 V3.0
Acquisition time (Time to first fix)	<ul style="list-style-type: none">▪ Hot start: 1 second▪ Cold start: 30 seconds
Sensitivity	Indoor sensitivity (tracking mode): -162 dBm

Protocols

- Network: TCP/IP, UDP/IP, DNS
- Routing: NAT, Host Port Routing, DHCP, PPPoE, VLAN, VRRP, Reliable Static Route
- Applications: SMS, Telnet/SSH, Reverse Telnet, SMTP, SNMP, SNTP
- Serial: TCP/UDP PAD mode, Modbus (ASCII, RTU, Variable), PPP
- GNSS: NMEA 0183 V 3.0, TAIP, RAP, Xora

Wi-Fi Performance

Technology	Frequency	MIMO	20 MHz ^a	40 MHz ^a	80 MHz ^a
802.11n	2.4 GHz	1 × 1	72 Mbps		
	5 GHz	1 × 1	100 Mbps	150 Mbps	
802.11ac	5 GHz	1 × 1	87 Mbps	200 Mbps	433 Mbps

a. Theoretical maximum performance. Actual data rates vary.

Wi-Fi Channels Supported

Note: By default, ALEOS enables all supported Wi-Fi channels. You can set the number of enabled Wi-Fi channels in ACEmanager or ALMS using the Wi-Fi Country Code setting. The default Country Code is United States. All other Country Code settings configure a subset of channels; they do not enable channels beyond those available in the default setting.

	Channel	Frequency (GHz)	20 MHz	40 MHz	80 MHz
2.4 GHz	1	2.412	✓		
	2	2.417	✓		
	3	2.422	✓		
	4	2.427	✓		
	5	2.432	✓		
	6	2.437	✓		
	7	2.442	✓		
	8	2.447	✓		
	9	2.452	✓		
	10	2.457	✓		
	11	2.462	✓		

	Channel	Frequency (GHz)	20 MHz	40 MHz	80 MHz
5 GHz	36	5.180	✓	✓	✓
	40	5.200	✓	✓	✓
	44	5.220	✓	✓	✓
	48	5.240	✓	✓	✓
	149	5.745	✓	✓	✓
	153	5.765	✓	✓	✓
	157	5.785	✓	✓	✓
	161	5.805	✓	✓	✓
	165	5.825	✓		

Wi-Fi Antenna Gain

The AirLink LX60 is compliant with the RF exposure requirements at 20 cm separation distance specified in EN 62311:2008 and 1999/519/EC for mobile exposure conditions, provided the maximum antenna gain does not exceed the limits given in the table below.

Table 3-5: Maximum Wi-Fi Antenna Gain

Frequency Band	Maximum Antenna Gain
2.4 GHz	3.25 dBi
5 GHz	5 dBi

Radio Frequency Bands

To determine which radio module your router has, refer to the label on the bottom of the router, or in ACEmanager, go to Status > About, and check the Radio Module Type field.

Note: All SKU support indicated in Table 3-6, Table 3-7, Table 3-8, Table 3-9, Table 3-10, and Table 3-11 is provisional.

Table 3-6: LX60 Radio Module WP7601 North America and EMEA

Radio Technology	SKU		Band	Frequencies
	Verizon Wireless			
LTE	✓		Band 4	Tx: 1710–1755 MHz Rx: 2110–2155 MHz
	✓		Band 13	Tx: 777–787 MHz Rx: 746–756 MHz

Table 3-7: LX60 Radio Module WP7603 North America

Radio Technology	SKU		Band	Frequencies
	Generic	AT&T		
LTE	✓	✓	Band 2	Tx: 1850–1910 MHz Rx: 1930–1990 MHz
	✓	✓	Band 4	Tx: 1710–1755 MHz Rx: 2110–2155 MHz
	✓	✓	Band 5	Tx: 824–849 MHz Rx: 869–894 MHz
	✓	✓	Band 12	Tx: 699–716 MHz Rx: 729–746 MHz
WCDMA	✓	✓	Band 2	Tx: 1850–1910 MHz Rx: 1930–1990 MHz
	✓	✓	Band 4	Tx: 1710–1755 MHz Rx: 2110–2155 MHz
	✓	✓	Band 5	Tx: 824–849 MHz Rx: 869–894 MHz

Table 3-8: LX60 Radio Module WP7607 EMEA

Radio Technology	SKU	Band	Frequencies
	Generic		
LTE	✓	Band 1	Tx: 1920–1980 MHz Rx: 2110–2170 MHz
	✓	Band 3	Tx: 1710–1785 MHz Rx: 1805–1880 MHz
	✓	Band 7	Tx: 2500–2570 MHz Rx: 2620–2690 MHz
	✓	Band 8	Tx: 880–915 MHz Rx: 925–960 MHz
		Band 20	Tx: 832–862 MHz Rx: 791–821 MHz
		Band 28	Tx: 703–748 MHz Rx: 758–803 MHz
WCDMA	✓	Band 1	Tx: 1920–1980 MHz Rx: 2110–2170 MHz
	✓	Band 8	Tx: 880–915 MHz Rx: 925–960 MHz
GSM/GPRS/EDGE		E-GSM 900	Tx: 880–915 MHz Rx: 925–960 MHz
		DCS 1800	Tx: 1710–1785 MHz Rx: 1805–1880 MHz

Table 3-9: LX60 Radio Module WP7610 North America

Radio Technology	SKU	Band	Frequencies
	Generic		
LTE	✓	Band 2	Tx: 1850–1910 MHz Rx: 1930–1990 MHz
	✓	Band 4	Tx: 1710–1755 MHz Rx: 2110–2155 MHz
	✓	Band 5	Tx: 824–849 MHz Rx: 869–894 MHz
	✓	Band 12	Tx: 699–716 MHz Rx: 729–746 MHz
	✓	Band 13	Tx: 777–787 MHz Rx: 746–756 MHz
	✓	Band 14	Tx: 788–798 MHz Rx: 758–768 MHz
	✓	Band 17	Tx: 704–716 MHz Rx: 734–746 MHz
	✓	Band 66	Tx: 1710–1780 MHz Rx: 2110–2200 MHz
WCDMA	✓	Band 2	Tx: 1850–1910 MHz Rx: 1930–1990 MHz
	✓	Band 4	Tx: 1710–1755 MHz Rx: 2110–2155 MHz
	✓	Band 5	Tx: 824–849 MHz Rx: 869–894 MHz

Table 3-10: LX60 Radio Module WP7609 Australia and New Zealand

Radio Technology	SKU	Band	Frequencies
	Generic		
LTE	✓	Band 1	Tx: 1920–1980 MHz Rx: 2110–2170 MHz
	✓	Band 3	Tx: 1710–1785 MHz Rx: 1805–1880 MHz
	✓	Band 5	Tx: 824–849 MHz Rx: 869–894 MHz
	✓	Band 7	Tx: 2500–2570 MHz Rx: 2620–2690 MHz
		Band 8	Tx: 880–915 MHz Rx: 925–960 MHz
		Band 28	Tx: 703–748 MHz Rx: 758–803 MHz
WCDMA	✓	Band 1	Tx: 1920–1980 MHz Rx: 2110–2170 MHz
		Band 5	Tx: 824–849 MHz Rx: 869–894 MHz
	✓	Band 8	Tx: 880–915 MHz Rx: 925–960 MHz

Table 3-11: LX60 Radio Module WP7702 Worldwide

Radio Technology	Module Firmware	Band	Frequencies
	Generic		
LTE	✓	Band 1	Tx: 1920–1980 MHz Rx: 2110–2170 MHz
	✓	Band 2	Tx: 1850–1910 MHz Rx: 1930–1990 MHz
	✓	Band 3	Tx: 1710–1785 MHz Rx: 1805–1880 MHz
	✓	Band 4	Tx: 1710–1755 MHz Rx: 2110–2155 MHz
	✓	Band 5	Tx: 824–849 MHz Rx: 869–894 MHz

Table 3-11: LX60 Radio Module WP7702 Worldwide

Radio Technology	Module Firmware	Band	Frequencies
	Generic		
	✓	Band 8	Tx: 880–915 MHz Rx: 925–960 MHz
	✓	Band 12	Tx: 699–716 MHz Rx: 729–746 MHz
	✓	Band 13	Tx: 777–787 MHz Rx: 746–756 MHz
	✓	Band 17	Tx: 704–716 MHz Rx: 734–746 MHz
	✓	Band 18	Tx: 815–830 MHz Rx: 860–875 MHz
	✓	Band 19	Tx: 830–845 MHz Rx: 875–890 MHz
	✓	Band 20	Tx: 832–862 MHz Rx: 791–821 MHz
	✓	Band 26	Tx: 814–849 MHz Rx: 859–894 MHz
	✓	Band 28	Tx: 703–748 MHz Rx: 758–803 MHz
GSM/GPRS	✓	GSM 850	Tx: 824–849 MHz Rx: 869–894 MHz
	✓	E-GSM 900	Tx: 880–915 MHz Rx: 925–960 MHz
	✓	DCS 1800	Tx: 1710–1785 MHz Rx: 1805–1880 MHz
	✓	PCS 1900	Tx: 1850–1910 MHz Rx: 1930–1990 MHz

Radio Module Conducted Transmit Power

The following tables provide radio module conducted transmit power specifications. The radio module type is printed on the label on the bottom of the router and is available in ACEmanager (Status > About).

Table 3-12: Radio Module WP7601 Conducted Transmit Power

Band	Conducted Tx Power (dBm)	Notes
LTE		
Bands 4, 13	+23±1	Connectorized (Class 3)

Table 3-13: Radio Module WP7603 Conducted Transmit Power

Band	Conducted Tx Power (dBm)	Notes
LTE		
Bands 2, 4, 5, 12	+23±1	Connectorized (Class 3)
WCDMA		
Band 2 Band 4 Band 5 (UMTS 850 12.2 kbps)	+23±1	Connectorized (Class 3)

Table 3-14: Radio Module WP7607 Conducted Transmit Power

Band	Conducted Tx Power (dBm)	Notes
LTE		
Bands 1, 3, 7, 8, 20, 28	+23±1	Connectorized (Class 3)
WCDMA		
Bands 1, 8	+23±1	Connectorized (Class 3)
GSM/GPRS/EDGE		
E-GSM 900	+33±1	GMSK mode (Class 4)
	+27±1	8PSK mode (Class E2)
DCS 1800	+30±1	GMSK mode (Class 1)
	+26±1	8PSK mode (Class E2)

Table 3-15: Radio Module WP7609 Conducted Transmit Power

Band	Conducted Tx Power (dBm)	Notes
LTE		
Bands 1, 3, 5, 7, 8, 28	+23±1	Connectorized (Class 3)
WCDMA		
Bands 1, 5, 8	+23±1	Connectorized (Class 3)

Table 3-16: Radio Module WP7610 Conducted Transmit Power

Band	Conducted Tx Power (dBm)	Notes
LTE		
Bands 2, 4, 5, 12, 13, 14, 17, 66	+23±1	Connectorized (Class 3)
WCDMA		
Bands 2, 4, 5	+23±2	Connectorized (Class 3)

Table 3-17: Radio Module WP7702 Conducted Transmit Power

Band	Conducted Tx Power (dBm)	Notes
LTE		
Bands 1, 2, 3, 4, 5, 8, 12, 13, 17, 18, 19, 20, 26, 28	+23±1	Connectorized (Class 3)
GSM/GPRS/EDGE		
GSM 850	+32±1	GMSK mode (Class 4)
	+27±1	8PSK mode (Class E2)
E-GSM 900	+32±1	GMSK mode (Class 4)
	+27±1	8PSK mode (Class E2)
DCS 1800	+29±1	GMSK mode (Class 1)
	+26±1	8PSK mode (Class E2)
PCS 1900	+29±1	GMSK mode (Class 1)
	+26±1	8PSK mode (Class E2)

GNSS Bands supported

Table 3-18: GNSS Bands Supported

Band	Frequency
GPS	1575.42 MHz
GLONASS	1597.52–1605.92 MHz
Galileo	1575.42 MHz
BeiDou	1561.098 MHz

Mechanical Specifications

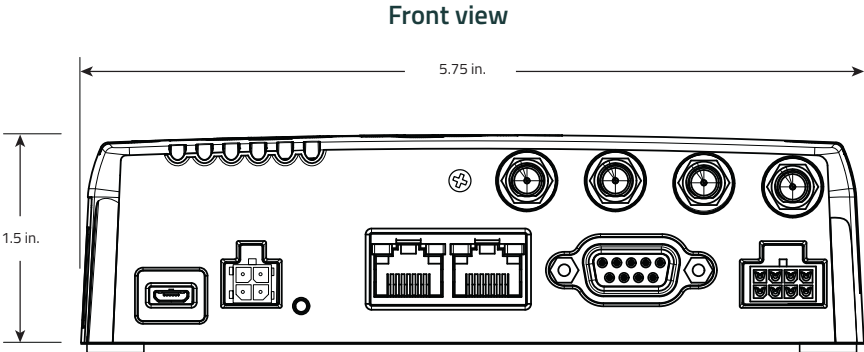

Weight: 270 g (9.5 oz.)

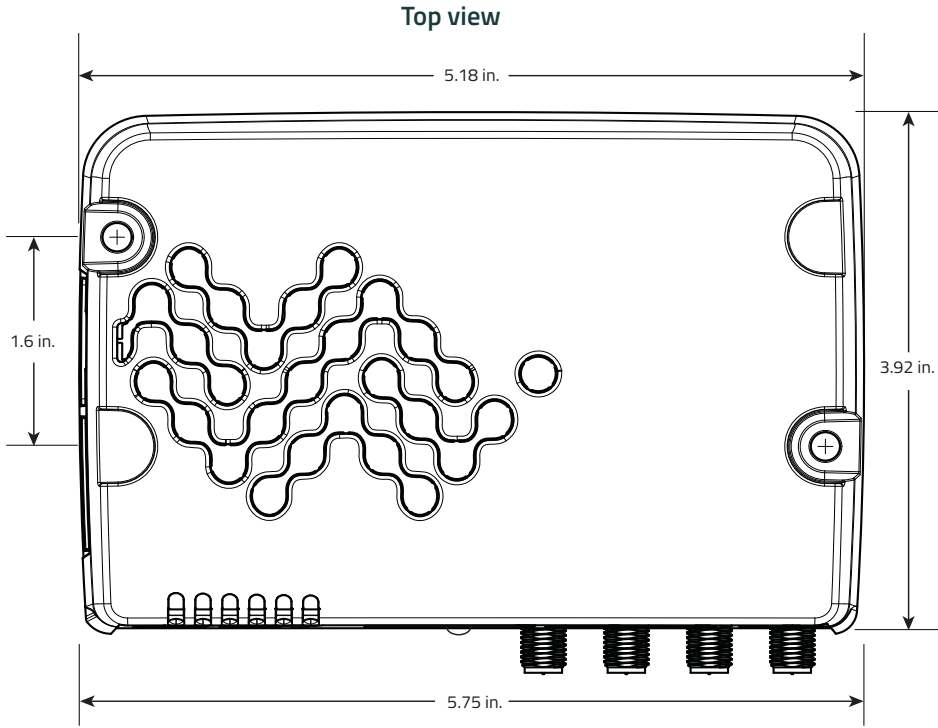

Figure 3-3: LX60 Mechanical Specifications

4: Regulatory Information

Important Information for North American Users

Note: This equipment has been tested and found to comply with the limits for a Class B digital device, pursuant to part 15 of the FCC Rules. These limits are designed to provide reasonable protection against harmful interference in a residential installation. This equipment generates, uses and can radiate radio frequency energy and, if not installed and used in accordance with the instructions, may cause harmful interference to radio communications. However, there is no guarantee that interference will not occur in a particular installation. If this equipment does cause harmful interference to radio or television reception, which can be determined by turning the equipment off and on, the user is encouraged to try to correct the interference by one or more of the following measures:

- *Reorient or relocate the receiving antenna.*
 - *Increase the separation between the equipment and receiver.*
 - *Connect the equipment into an outlet on a circuit different from that to which the receiver is connected.*
 - *Consult the dealer or an experienced radio/TV technician for help.*
-

Warning: *Changes or modifications to this device not expressly approved by Semtech could void the user's authority to operate this equipment.*

Avertissement : *Les changements ou modifications de cet appareil non expressément approuvés par Semtech peuvent annuler le droit de l'utilisateur à utiliser cet équipement.*

RF Exposure

In accordance with FCC/IC requirements of human exposure to radio frequency fields, the radiating element shall be installed such that a minimum separation distance of 20 cm should be maintained from the antenna and the user's body.

Warning: *This product is only to be installed by qualified personnel.*

Avertissement : *Ce produit doit être uniquement installé par un personnel qualifié.*

To comply with FCC/IC regulations limiting both maximum RF output power and human exposure to RF radiation, the maximum antenna gain must not exceed the specifications listed below for the device used.

Maximum Antenna Gain

The antenna gain must not exceed the limits and configurations shown in the following tables:

Table 4-1: LX60 WP7601 Maximum Antenna Gain

Device	Frequency Band	FCC ID/IC Number N7NWP76A/2417C-WP76A Maximum Antenna Gain (dBi)
AirLink LX60	4	6
	13	6

Table 4-2: LX60 WP7603 Maximum Antenna Gain

Device	Frequency Band	FCC ID/IC Number N7NWP76C/2417C-WP76C Maximum Antenna Gain (dBi)
AirLink LX60	2	6
	4	6
	5	6
	12	6

Table 4-3: WP7607/7609 Maximum Antenna Gain

Device	Frequency Band	FCC ID/IC Number N7NWP76C/2417C-WP76C Maximum Antenna Gain (dBi)
AirLink LX60	1	Must not exceed antenna gains due to RF exposure and ERP/EIRP limits, as listed in the module's FCC grant.
	3	
	7	
	8	
	20	
	28	

Table 4-4: WP7610 Maximum Antenna Gain

Device	Frequency Band	FCC ID/IC Number N7NWP7610/2417C-WP7610 Maximum Antenna Gain (dBi)
AirLink LX60	2	6
	4	6
	5	6
	12	6
	13	6
	14	6
	17	6
	66	6

Table 4-5: WP7702 Antenna Gain Specifications

Device	Frequency Band	FCC ID/IC Number N7NWP77B/2417C-WP77B	
		Maximum antenna gain (dBi)	
		Standalone	Collocated ^a
AirLink LX60	2	9	8
	4 ^b	6	6
	5	7	6
	12	6	6
	13	6	6
	17 ^c	6	6
	26	7	6
	GSM 850	4	3
	PCS 1900	3	3

- a. Antenna gain limit when module collocated with Wi-Fi/Wimax/BT radios
b. B4—CAT-M1 only
c. B17—CAT-NB1 only

WEEE Notice



If you purchased your AirLink LX60 in Europe, please return it to your dealer or supplier at the end of its life. WEEE products may be recognized by their wheeled bin label on the product label.

A: Accessories

DC Power Cable (Black Connector)

Table A-1: DC Power Cable

DC Power Cable	
Part Number	2000522
Product Release	2016

Components:

- ❶ 1 UL2464 20 AWG × 4 core cable
- ❷ 4 Molex female crimp terminals /AWG 20-24, 250 V, 5 A max, phosphor bronze tin-plated (part number 43030-0001)
- ❸ 1 Molex male 2×2P Ph: 3.0 mm housing, 250 V, 5 A max, PA65 black UL94V-0 (part number 43025-0408)

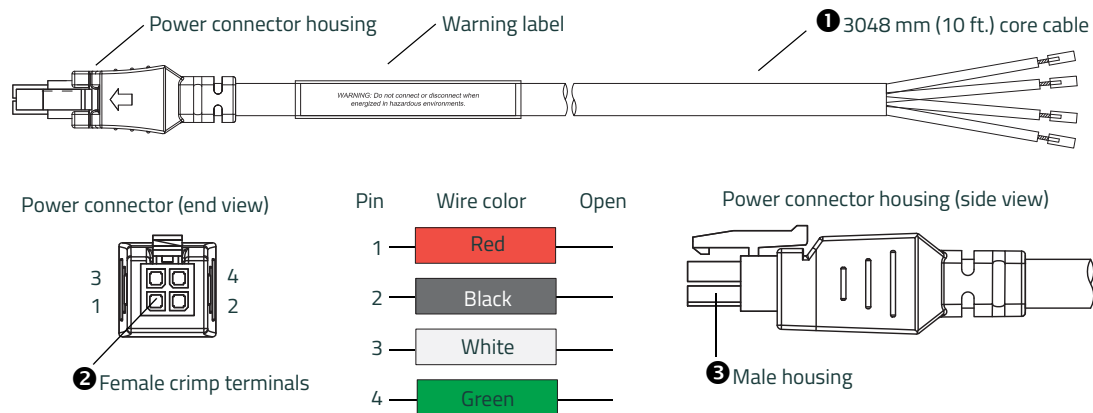

Figure A-1: DC Cable Specifications

AC Power Adapter (Black Connector)

Table A-2: AC Power Adapter

AC Power Adapter	
Part Number	2000579
Product Release	2016

AC Power Adapter Input

Table A-3: Input Specifications

	Minimum	Typical	Maximum
Input			
Input Voltage	90 VAC	100–240 VAC	264 VAC
Input Frequency	47 Hz	50/60 Hz	63 Hz
<p><i>Note: Input voltage range is 90 VAC to 264 VAC.</i> <i>Maximum input current is 500 mA at 100–240 VAC.</i> <i>Inrush current will not exceed 75 A at 100–240 VAC input and maximum load from a cold start at 25 °C.</i></p>			

AC Power Adapter Output

Table A-4: AC Power Adapter Output Specifications

	Minimum	Typical	Maximum	Test conditions
Output Voltage	11.4 VDC	12.0 VDC	12.6 VDC	0 ~ 1.5 A loading

AC Power Adapter Environmental Specifications

Table A-5: AC Power Adapter Environmental Specifications

Operating	
Operating Temperature	0°C ~ 40°C (operates normally)
Relative Humidity	10% ~ 90%
Altitude	Sea level to 2,000 meters
Vibration	1.0 mm, 10–55 Hz, 15 minutes per cycle for each axis (X, Y, Z)
Non-operating	
Storage Temperature	-30°C ~ 70°C
Relative Humidity	10% ~ 90%
Vibration and Shock	MIL-STD-810D, method 514

AC Power Adapter Reliability and Quality Control

AC Power Adapter MTBF

When the power supply is operating within the limits of this specification, the MTBF is at least 200,000 hours at 25°C (MIL-HDBK-217F).

AC Power Adapter Safety Standards

The power supply is certified with the following international regulatory standards:

Table A-6: AC Power Adapter Safety standards

Regulatory Agency	Country or Region	Certified	Standard
UL	USA	Approved	UL60950-1
GS	Europe	Approved	EN60950-1
CE	Europe	Approved	EN60950-1
SAA	Australia	Approved	AS/NZS 60950
CCC	China	Approved	GB4943
CUL	Canada	Approved	CSA C22.2 NO.60950-1

AC Power Adapter EMC Standards

The power supply meets the radiated and conducted emission requirements for EN55022, FCC Part 15, Class B, GB9254.

AC Power Adapter Hazardous Substances

- EU Directive 2011/65/EU "RoHS"
- EU Directive 2012/19/EU "WEEE"
- REACH

AC Power Adapter Energy Efficiency

The AC adapter complies with International Efficiency Levels, as shown in [Table A-7](#).

Table A-7: AC Adapter Energy Efficiency

Supplied Input	No-load Power Consumption	Average Active Mode Efficiency	International Efficiency Level
115 VAC, 60 Hz	Less than 0.1 W	Greater than 85%	VI
230 VAC, 50 Hz	Less than 0.3 W	Greater than 80.4%	V

I/O Connector Cable

Table A-8: I/O Connector Cable

I/O Connector Cable	
Part Number	6001004
Product Release	2016

Components:

- ❶ 1 UL2464 5 core × 20 AWG cable
- ❷ 5 Molex female crimp terminals /AWG 20-24, 300VAC, 3A rating, phosphor bronze tin-plated (part number 43030-0001)
- ❸ 1 Molex male 2×4P Ph: 3.0 mm housing, PA65 black UL94V-O (part number 43025-0800)

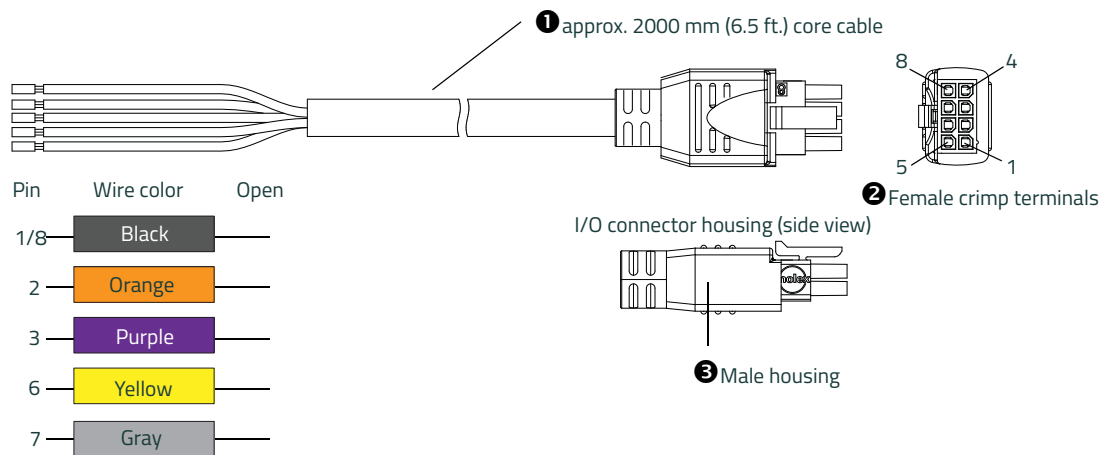

Figure A-2: I/O Cable Specifications

Vehicle Bus Cables

The vehicle bus interface cables are shielded and terminated, and designed for use with the LX60 Series.

Table A-9: Vehicle Bus Cable Accessories

Part Number	Description	Length	Connector
6001153	OBD-II cable	5 meters	Deutsch 9-pin Type I/II
6001154	J1939 cable	5 meters	OBD-II

Table A-10: Vehicle Bus Cable Pin-outs

J1939 Pin	ODB-II Pin	LX60 Aux I/O Pin	Function
C	6	4	CAN-H
D	14	5	CAN-L
A	5	8	Ground

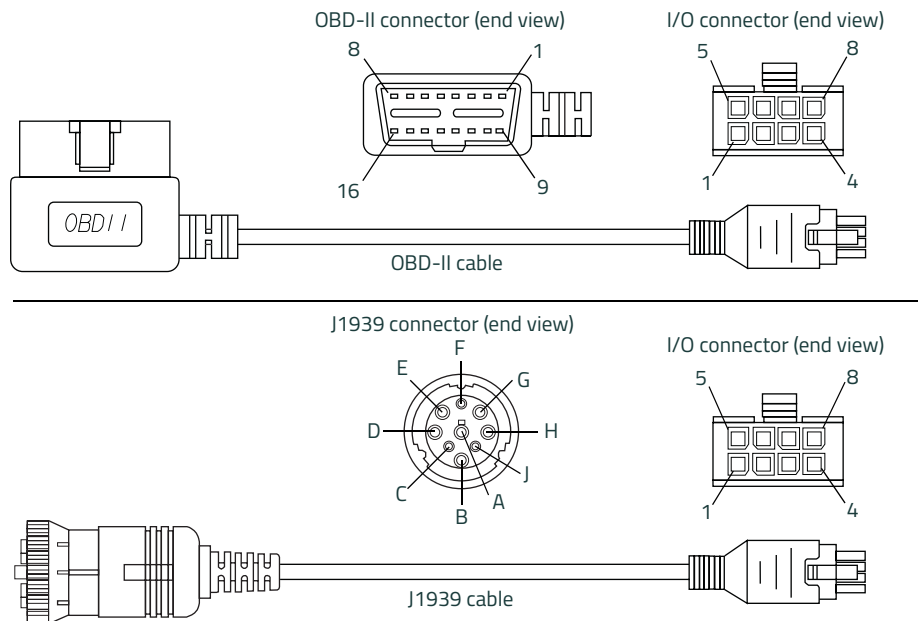

Figure A-3: Vehicle Bus Cables

I/O Cable

The AirLink auxiliary I/O cable is unshielded and terminated on one end, and designed for use with the AirLink LX60, XR80/XR90, and MP70.

Table A-11: I/O Cable

Part Number	Description ^a	Length	Connector
6001004	XR/MP/LX I/O Cable	2 meters	8-pin Molex Micro-Fit connector

a. The description used by vendors for this cable may indicate some combination of XR, MP, or LX model. However, these cables are intended for XR80/XR90, MP70, and LX60 routers.

Table A-12: I/O Cable Pin-out

I/O Cable Pin	Wire Color	Function	Notes
1	Black	Ground	Shorted to Pin 8 with 22AWG
2	Orange	IO4_IN	
3	Purple	IO3_IN	
4	Not connected		
5	Not connected		
6	Yellow	IO2_IN_A	
7	Gray	IO1_IN_A	
8	Black (22AWG)	Ground	Shorted to Pin 1 with 22AWG

- ❶ 1 UL2464 20AWGx5C unshielded, PVC black cable. Outer diameter 5.80 mm
- ❷
 - 5 Molex Micro-Fit 3.0 female crimp terminals: AWG 20-24, 600V, HSM copper tin-plated (part number 430300001)
 - 1 Molex Micro-Fit 3.0 female crimp terminal: AWG 18, 600V, HSM copper tin-plated (part number 458070003)
- ❸ 1 Molex male 8 circuit Micro-Fit 3.0 receptacle housing (part number 430250800)

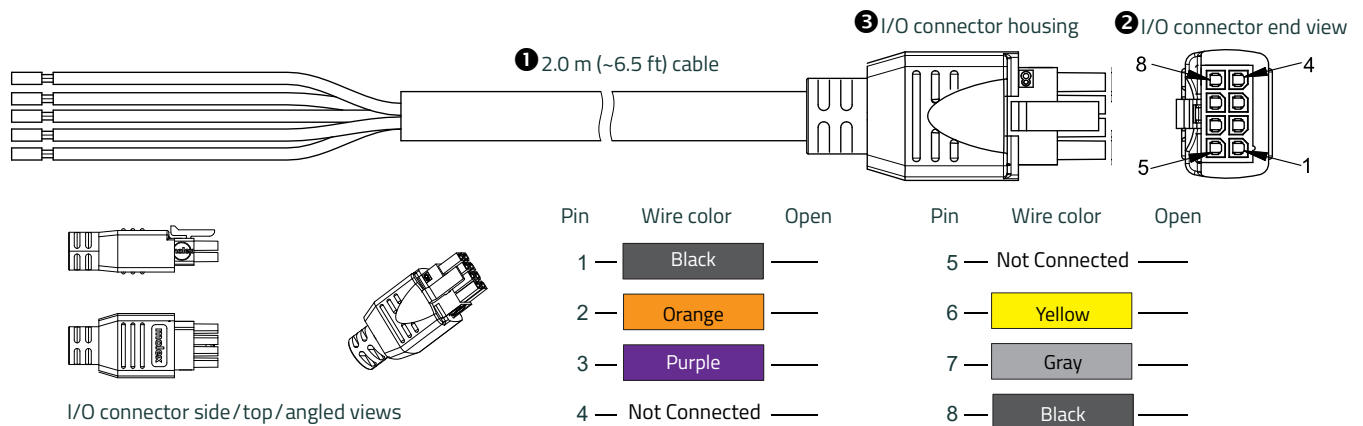

Figure A-4: IO Cable Specifications

Index

A

- AC power adapter, specifications, [61](#)
- Accessories, [11](#)
- ACEmanager, [33](#)
- AirLink Management Service, [33](#)
- ALEOS software, [33](#)
- AMM, [34](#)
- Analog input, [27](#)
- Antenna
 - Connecting, [15](#)
 - Gain, [57](#)
 - Maximum gain, [57](#)
 - Recommended separation, [16](#)
- AT commands, [34](#)

C

- Cables, connecting, [16](#)
- Certification
 - Mobile Network Operator, [37](#)
- Communication
 - AT commands, using, [34](#)
 - Command line prompt, using, [30](#)
- Conducted transmit power, [52](#)
- Configuring the router
 - AirLink Management Service, [33](#)
 - AT commands, [34](#)
- Current sink, [29](#)

D

- DC power cable
 - Specifications, [60](#)
 - Wires, [18](#)
- DC voltage transients, [17](#)
- Digital I/O specifications, [43](#)
- Digital input, [26](#)
- Digital output, [30](#)
- Digital output/open drain, [30](#)

E

- Ethernet, LEDs, [32](#)

F

- Features, [8](#)
- Fusing, [17](#)

G

- GNSS, [44](#)
- GNSS, bands supported, [54](#)
- Grounding the chassis, [14](#)

H

- High side pull-up/dry contact switch input, [27](#)

- Host Interfaces, [40](#)

I

- I / O Configuration, [23](#)
- I/O auxiliary connector, [23](#)
- I/O pins, [23](#)
- Input
 - Analog, [27](#)
 - Dry contact switch, [27](#)
 - Ignition switch, [26](#)
- Installation
 - Connect data cables, [16](#)
 - Connect power cable, [16](#)
 - Connect vehicle bus cable, [22](#)
 - Connecting antennas, [15](#)
 - Fixed (with I/O), [19](#)
 - Fixed (without I/O), [19](#)
 - Overview, [12](#)
 - Tools and materials required, [12](#)
 - Vehicle, [20](#)
- IP address, obtaining with command line prompt, [30](#)

L

- LED
 - Description of LED, [30](#)
 - Ethernet, [32](#)
- Low side current sink output, [29](#)
- LTE, bands supported, [38](#)

M

- MIMO, [15](#)
- MTBF
 - AC adapter, [62](#)

O

- Open drain, [30](#)
- Operating voltage, [42](#)
- Output, digital, [30](#)

P

- Pinging the router with command line prompt, [30](#)
- Power
 - Connecting, [16](#)
 - Connector, [16](#)
 - input specifications, [43](#)
 - power supply specifications, [43](#)
- Power consumption, sample scenarios, [10](#)
- Protocols, [44](#)
- Pull-up resistor, [27](#)
- Pulse counter, [25](#)

R

- Rebooting, [34](#)

Recovery mode, [35](#)
Regulatory information, [56](#)
Regulatory specifications, [62](#)
Reset to factory default settings, [35](#)
RF exposure, [57](#)
RF specifications, [15](#)

S

Screw Torque, [42](#)
Serial connector pin-out, [41](#), [42](#)
Serial port, [41](#)
Software, configure, [33](#)
Specifications, [37](#)

- Environmental, [37](#)
- GNSS, [44](#)
- Regulatory, [62](#)
- RF, [15](#)

Standards, regulatory, [62](#)

T

Tools required for install, [12](#)

V

Voltage, input and ripple range, [43](#)

W

Warranty, [11](#)
WEEE, [59](#)
Wi-Fi performance, [45](#)
Wiring diagrams, [18](#)