



AirPrime RC7611

Hardware Integration Guide



SIERRA
WIRELESS®

41113583
Rev 2.1

Important Notice

Due to the nature of wireless communications, transmission and reception of data can never be guaranteed. Data may be delayed, corrupted (i.e., have errors) or be totally lost. Although significant delays or losses of data are rare when wireless devices such as the Sierra Wireless modem are used in a normal manner with a well-constructed network, the Sierra Wireless modem should not be used in situations where failure to transmit or receive data could result in damage of any kind to the user or any other party, including but not limited to personal injury, death, or loss of property. Sierra Wireless accepts no responsibility for damages of any kind resulting from delays or errors in data transmitted or received using the Sierra Wireless modem, or for failure of the Sierra Wireless modem to transmit or receive such data.

Safety and Hazards

Do not operate the Sierra Wireless modem in areas where blasting is in progress, where explosive atmospheres may be present, near medical equipment, near life support equipment, or any equipment which may be susceptible to any form of radio interference. In such areas, the Sierra Wireless modem **MUST BE IN AIRPLANE MODE OR POWERED OFF**. The Sierra Wireless modem can transmit signals that could interfere with this equipment.

Do not operate the Sierra Wireless modem in any aircraft, whether the aircraft is on the ground or in flight. In aircraft, the Sierra Wireless modem **MUST BE IN AIRPLANE MODE OR POWERED OFF**. When operating, the Sierra Wireless modem can transmit signals that could interfere with various onboard systems.

Note: Some airlines may permit the use of cellular phones while the aircraft is on the ground and the door is open. Sierra Wireless modems may be used at this time.

The driver or operator of any vehicle should not operate the Sierra Wireless modem while in control of a vehicle. Doing so will detract from the driver or operator's control and operation of that vehicle. In some states and provinces, operating such communications devices while in control of a vehicle is an offence.

Limitation of Liability

The information in this manual is subject to change without notice and does not represent a commitment on the part of Sierra Wireless. SIERRA WIRELESS AND ITS AFFILIATES SPECIFICALLY DISCLAIM LIABILITY FOR ANY AND ALL DIRECT, INDIRECT, SPECIAL, GENERAL, INCIDENTAL, CONSEQUENTIAL, PUNITIVE OR EXEMPLARY DAMAGES INCLUDING, BUT NOT LIMITED TO, LOSS OF PROFITS OR REVENUE OR ANTICIPATED PROFITS OR REVENUE ARISING OUT OF THE USE OR INABILITY TO USE ANY SIERRA WIRELESS PRODUCT, EVEN IF SIERRA WIRELESS AND/OR ITS AFFILIATES HAS BEEN ADVISED OF THE POSSIBILITY OF SUCH DAMAGES OR THEY ARE FORESEEABLE OR FOR CLAIMS BY ANY THIRD PARTY.

Notwithstanding the foregoing, in no event shall Sierra Wireless and/or its affiliates aggregate liability arising under or in connection with the Sierra Wireless product, regardless of the number of events, occurrences, or claims giving rise to liability, be in excess of the price paid by the purchaser for the Sierra Wireless product.

Patents

This product may contain technology developed by or for Sierra Wireless Inc. This product is manufactured or sold by Sierra Wireless Inc. or its affiliates under one or more patents licensed from MMP Portfolio Licensing.

Copyright

©2020 Sierra Wireless. All rights reserved.

Trademarks

Sierra Wireless[®], AirPrime[®], AirLink[®], AirVantage[®] and the Sierra Wireless logo are registered trademarks of Sierra Wireless, Inc.

Windows[®] and Windows Vista[®] are registered trademarks of Microsoft Corporation.

QUALCOMM[®] is a registered trademark of QUALCOMM Incorporated. Used under license.

Other trademarks are the property of their respective owners.

Contact Information

Sales information and technical support, including warranty and returns	Web: sierrawireless.com/company/contact-us/ Global toll-free number: 1-877-687-7795 6:00 am to 5:00 pm PST
Corporate and product information	Web: sierrawireless.com

Revision History

Revision Number	Release Date	Changes
1.0	January 23, 2020	Document creation
2.0	May 25, 2020	New FCC ID on 19 Added IC ID on 19 Added Industry Canada Statement
2.1	June 4, 2020	Added new section in Industry Canada Statement Changed FCC to FCC/IC

>> Contents

Introduction	5
Accessories	5
Power	6
Power Supply	6
Module Power States	6
RF Specifications	8
Conducted Tx Power	9
Routing Constraints and Recommendations	10
General Rules and Recommendations	10
PCB Layout Recommendations	10
Power Supply	10
Antenna	11
PCB Specifications for the Application Board	11
Recommended PCB Land Pattern	11
Routing Constraints	11
Power Supply	11
UIM Interface	12
RF Circuit	12
USB Interface	13
Thermal Considerations	13
EMC and ESD Recommendations	13
Mechanical Integration	14
Signal Reference Schematics	15
Regulatory Compliance and Industry Certifications	17
Important Notice	17
Safety and Hazards	17
Important Compliance Information for North American Users	18
Industry Canada Statement	20

>> 1: Introduction

The AirPrime RC7611 is an industrial-grade LGA 239-pad module that provides voice and data connectivity on LTE networks. The module also provides GNSS functionality as a SKU-configuration.

Note: Throughout this document, references to RC7611 should be read as RC7611 and RC7611-1 unless variants are called out separately.

Accessories

A hardware development kit is available for AirPrime RC Series modules. The kit contains hardware components for evaluating and developing with the module, including:

- Development board
- Cables
- Antennas (additional antennas may be required to support all bands)
- Other accessories

>> 2: Power

Power Supply

The host provides power to the AirPrime RC7611 through multiple power and ground pins. The host must provide safe and continuous power at all times; the module does not have an independent power supply, or protection circuits to guard against electrical issues.

For detailed pinout and voltage/current requirements of this module, see the *AirPrime RC7611 Product Technical Specification*.

Module Power States

The module has four basic power states, as described in [Table 2-1](#).

Table 2-1: Supported Power States

State	Description
Active	<p>Module is fully powered (Linux can be run in the Application Core; modem is on) and operating in one of the following modes:</p> <ul style="list-style-type: none"> • Full function (WWAN radio active; GNSS radio can be turned on/off)—Highest power consumption. • Idle mode (WWAN radio on; module is registered on network, but no active connection; GNSS radio can be turned on/off) • Airplane mode (WWAN radio off; GNSS radio can be active if allowed by PRI) • eDRX (Extended Discontinuous Reception)—eDRX mode provides a ‘flexible sleep’ for the modem, which significantly reduces energy consumption.
Sleep	<ul style="list-style-type: none"> • Lower power consumption than Active state, but higher than PSM. • Application Core is sleeping; modem is in DRX/eDRX. The processor monitors signals (triggers) that can ‘wake’ the module. • Sleep state can be entered based on USB-SS (if USB is connected to the module), UART_DTR, wake_lock(), configured GPIOs, and QMI exchanges from the modem. <p>Note: On Windows systems, due to limitations of the Windows ECM driver, Sleep state is only supported if ECM is disabled or USB is disconnected.</p>

Table 2-1: Supported Power States

State	Description
PSM (Power Saving Mode)	<p>3GPP Release 12 introduced network support of PSM. PSM allows the module to negotiate, with the network, an extended period during which registration context with the network is retained while the module is unreachable. During the negotiated period, the module enters a very low-power dormant state.</p> <p>After the specified period, the modem and application processors boot up and the module sends a TAU (Tracking Area Update) to the network.</p> <p>After sending the TAU, the module remains active to allow any pending data to be exchanged with the network. Then, after a negotiated period of inactivity, the module automatically returns to PSM to repeat the cycle.</p>
OFF	<p>Module is OFF (no power to the system).</p> <p>Apply power for system to go to:</p> <ul style="list-style-type: none">• Active state (POWER_ON_N is asserted) <p>or</p> <ul style="list-style-type: none">• PSM (POWER_ON_N is de-asserted)

>> 3: RF Specifications

The AirPrime RC7611 operates on the frequency bands listed below.

Table 3-1: LTE Frequency Band Support

Band	Frequency (Tx) (MHz)	Frequency (Rx) (MHz)
B2	1850 – 1910	1930 – 1990
B4	1710 – 1755	2110 – 2155
B5	824 – 849	869 – 894
B12	699 – 716	729 – 746
B13	777 – 787	746 – 756
B14	788 – 798	758 – 768
B25	1850 – 1915	1930 – 1995
B26	814 – 849	859 – 894
B66	1710 – 1780	2110 – 2200
B71	663 – 698	617 – 652

Table 3-2: GNSS Frequency Band Support

Band	Frequencies (MHz)
GPS	1575.42 ± 1.023
GLONASS	1597.52–1605.92
Galileo	1575.42 ± 2.046
BeiDou	1561.098 ± 2.046

Conducted Tx Power

Table 3-3: Conducted Tx Max Output Power Tolerances — LTE

RF Band	Operating Condition	Minimum (dBm)	Typical (dBm)	Maximum (dBm)	Notes
B2	Normal (25°C)	21	23	24	Power class 3
B4	Normal (25°C)	21	23	24	Power class 3
B5	Normal (25°C)	21	23	24	Power class 3
B12	Normal (25°C)	21	23	24	Power class 3
B13	Normal (25°C)	21	23	24	Power class 3
B14	Normal (25°C)	21	23	24	Power class 3
B25	Normal (25°C)	21	23	24	Power class 3
B26	Normal (25°C)	21	23	24	Power class 3
B66	Normal (25°C)	21	23	24	Power class 3
B71	Normal (25°C)	21	23	24	Power class 3

>> 4: Routing Constraints and Recommendations

This section describes general routing constraints and recommendations for the AirPrime RC7611.

Note: This is a non-exhaustive list of suggested design guidelines. The developer is responsible for deciding whether to implement these guidelines.

General Rules and Recommendations

Clock and other high-frequency digital signals (e.g. serial buses) should be routed as far as possible from the module's analog signals.

If the application design makes it possible, all analog signals should be separated from digital signals by a ground trace on the PCB.

Tip: *Avoid routing any signals under the module on the application board.*

PCB Layout Recommendations

Ground pads should be re-flowed on to the host PCB with < 30% voiding to allow effective heat dissipation.

Power Supply

When designing the power supply, make sure that VBAT_BB/VBAT_RF meet the requirements listed in the *AirPrime RC7611 Product Technical Specification*.

Careful attention should be paid to the following:

- Power supply quality – PFM, or PSM systems should be avoided; Low ripple, linear regulation or PWM converters are preferred for low noise.
- Capacity to deliver high current peaks in a short time (for pulsed radio emission)
- VBAT_BB/VBAT_RF must support peak currents with an acceptable voltage drop that guarantees the minimum required VBAT_BB/VBAT_RF value.
- VBAT_BB/VBAT_RF signal pads must never exceed the maximum required VBAT_BB/VBAT_RF value, otherwise the module's power amplifier and GPS chipset may be severely damaged.
- A weakly-designed (not robust) power supply could affect EMC performance, the emission spectrum, and the phase error and frequency error.

Antenna

Sierra Wireless strongly recommends working with an antenna manufacturer either to develop an antenna adapted to the application, or to adapt an existing solution to the application.

For information on routing constraints for the RF circuit, see [RF Circuit on page 12](#).

PCB Specifications for the Application Board

Sensitive signals (such as audio, UIM, and clocks) should be protected by ground planes/fills. Routing sensitive signals close to noisy signals could result in noise being coupled.

Recommended PCB Land Pattern

Refer to *AirPrime RC Series Customer Process Guidelines*, available at <http://source.sierrawireless.com>.

Routing Constraints

Power Supply

If the following design recommendations are not followed, phase error (peak) and power loss could occur.

- Since the maximum peak current can reach 2.5 A, Sierra Wireless strongly recommends having a large width for the layout of the power supply signal (to avoid voltage loss between the external power supply and VBAT_BB/ VBAT_RF).

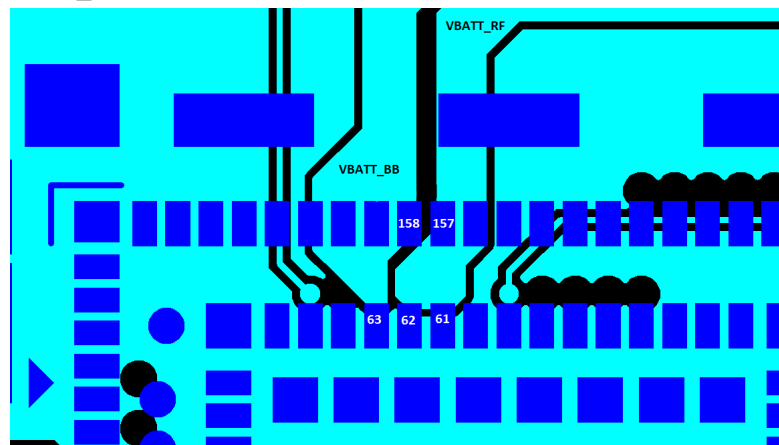

Figure 4-1: Power Supply Routing Example

Note: Figure 4-1 shows separate traces for VBAT_BB and VBAT_RF. If VBAT_BB and VBAT_RF share a single power supply, these traces should be connected.

Note: For optimal decoupling, place the capacitors on the underside of the board, directly under the pins.

- Filtering capacitors (100 nF to 1500 μ F) are recommended near the module's power supply.
- Attention should be paid to the ground trace or the ground plane on the application board for the power supply that supplies the module. The ground trace or ground plane, as well as the VBAT trace, must be able to support current peaks.
- If the ground trace between the module and the power supply is a copper plane, make sure it is a solid plane.
- Design routing to make sure total line impedance does not exceed 10 m Ω @ 217 Hz.

Ground Plane Connection

The AirPrime RC7611 requires a solid, central ground plane (with solder mask defined pads) located directly under the module. This will:

- Ensure high current signal returns
- Provide heat dissipation under higher operating temperatures

The ground plane should be connected (with vias) to the reference ground layer of the application board.

UIM Interface

- The length of the tracks between the AirPrime RC7611 and the UIM socket should be as short as possible. Maximum recommended length is 10cm.
- ESD protection is mandatory on the UIM lines unless there is no physical access to the UIM.
- The decoupling capacitor(s) should be placed as close as possible to the UIM card connector for the UIM1_VCC signal.

RF Circuit

The RF signal must be routed on the application board using tracks with a 50 Ω characteristic impedance.

The characteristic impedance depends on the dielectric, the track width and the ground plane spacing.

It is recommended to use stripline design if the RF path is fairly long (more than 3 cm), since microstrip design is not shielded. Consequently, the RF (transmit) signal may interfere with neighboring electronic circuits. In the same way, the neighboring electronics (micro-controllers, etc.) may interfere with the RF (receive) signal and degrade the reception performance.

USB Interface

When the USB interface is externally accessible, ESD protection is required on the USB_VBUS, USB_D+, and USB_D- signals.

Thermal Considerations

When transmitting, the AirPrime RC7611 can generate significant amounts of heat (due to the internal Power Amplifier) that must be dissipated in the host device for safety and performance reasons.

The amount of thermal dissipation required depends on the following factors:

- Supply voltage — Maximum power dissipation for these modules can be up to 3 W at voltage supply limits.
- Usage — Typical power dissipation values depend on the location within the host, amount of data transferred, etc.

To enhance heat dissipation:

- Maximize airflow over / around the module
- Locate the module away from other components that generate heat
- Ensure the module is connected to a solid ground plane

EMC and ESD Recommendations

EMC tests must be performed on the application as soon as possible to detect any potential problems.

When designing, special attention should be paid to:

- Possible spurious emissions radiated by the application to the RF receiver in the receiver band
- ESD protection — Typically, ESD protection is mandatory for externally accessible signals, including:
 - VBAT_RF/VBAT_BB
 - UIM (if accessible from outside)
 - Serial link
 - USB
 - Antennas
- Length of the UIM interface lines (preferably <10 cm)
- Length of the HSIC interface lines (<10 cm, as required by the HSIC specification)
- EMC protection on audio input/output (filters against 900 MHz emissions)
- Ground plane: Sierra Wireless recommends a common ground plane for analog/digital/RF grounds

Note: The AirPrime RC7611 does not include any protection against over-voltage.

The host device must provide adequate ESD protection on digital circuits and antenna ports as detailed in the following table.

Note: The level of protection required depends on your application.

Table 4-1: ESD Specifications ^{a,b}

Category	Connection	Specification
Operational	RF ports UIM connector USB connector UART connector	IEC-61000-4-2 - Level (Electrostatic Discharge Immunity Test) <ul style="list-style-type: none"> ± 6kV Contact ± 8kV Air
Non-operational	Host connector interface	Unless otherwise specified: <ul style="list-style-type: none"> JESD22-A114 ± 1kV Human Body Model JESD22-A115 ± 100V Machine Model JESD22-C101C ± 500V Charged Device Model

- a. ESD specifications are preliminary, subject to change.
- b. ESD protection is highly recommended at the point where the UIM contacts are exposed, and for any other signals that would be subjected to ESD by the user.

Mechanical Integration

Attention should be paid to:

- Antenna cable integration (bending, length, position, etc)
- Pads of the AirPrime RC7611 to be soldered to the ground plane
- Ensuring proper board layout
- Providing sufficient space around the module for heat dissipation

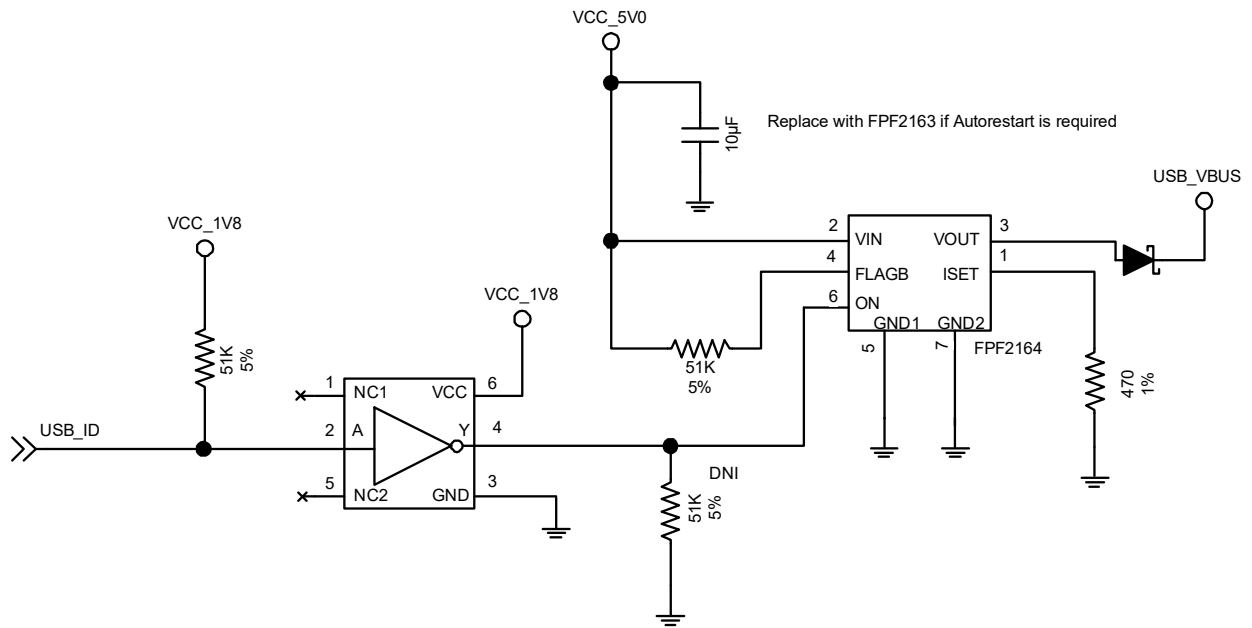

Figure 4-4: USB OTG Interface

>> 5: Regulatory Compliance and Industry Certifications

Important Notice

Due to the nature of wireless communications, transmission and reception of data can never be guaranteed. Data may be delayed, corrupted (i.e., have errors) or be totally lost. Although significant delays or losses of data are rare when wireless devices such as the Sierra Wireless modem are used in a normal manner with a well-constructed network, the Sierra Wireless modem should not be used in situations where failure to transmit or receive data could result in damage of any kind to the user or any other party, including but not limited to personal injury, death, or loss of property. Sierra Wireless accepts no responsibility for damages of any kind resulting from delays or errors in data transmitted or received using the Sierra Wireless modem, or for failure of the Sierra Wireless modem to transmit or receive such data.

Safety and Hazards

Do not operate your AirPrime RC7611:

- In areas where blasting is in progress
- Where explosive atmospheres may be present including refueling points, fuel depots, and chemical plants
- Near medical equipment, life support equipment, or any equipment which may be susceptible to any form of radio interference.

In such areas, the AirPrime RC7611 **MUST BE POWERED OFF**. Otherwise, the module can transmit signals that could interfere with this equipment.

In an aircraft, the AirPrime RC7611 **MUST BE POWERED OFF**. Otherwise, the module can transmit signals that could interfere with various onboard systems and may be dangerous to the operation of the aircraft or disrupt the cellular network. Use of a cellular phone in an aircraft is illegal in some jurisdictions. Failure to observe this instruction may lead to suspension or denial of cellular telephone services to the offender, or legal action or both.

Some airlines may permit the use of cellular phones while the aircraft is on the ground and the door is open. The AirPrime RC7611 may be used normally at this time.

Important Compliance Information for North American Users

The AirPrime RC7611 has been granted modular approval for mobile applications. Integrators may use the AirPrime RC7611 in their end products without additional FCC/IC certification if they meet the following conditions. Otherwise, additional FCC/IC approvals must be obtained.

1. The end product must use the RF trace design approved with the AirPrime RC7611. The Gerber file of the trace design can be obtained from Sierra Wireless upon request.
2. At least 20 cm separation distance between the antenna and the user’s body must be maintained at all times.
3. To comply with FCC/IC regulations limiting both maximum RF output power and human exposure to RF radiation, the maximum antenna gain including cable loss in a mobile-only exposure condition must not exceed the limits stipulated in [Table 5-1 on page 18](#).

Table 5-1: Antenna Gain Specifications

LTE Band	Frequency (MHz)	Maximum Antenna Gain (dBi)
2	1850–1910	6
4	1710–1755	6
5	824–849	6
12	699–716	6
13	777–787	6
14	788–798	6
25	1850–1915	6
26	814–849	6
66	1710–1780	6
71	663–698	6

4. The AirPrime RC7611 may transmit simultaneously with other collocated radio transmitters within a host device, provided the following conditions are met:
- Each collocated radio transmitter has been certified by FCC/IC for mobile application.
 - At least 20 cm separation distance between the antennas of the collocated transmitters and the user's body must be maintained at all times.
 - The radiated power of a collocated transmitter must not exceed the EIRP limit stipulated in [Table 5-2](#).

Table 5-2: Collocated Radio Transmitter Specifications

Device	Technology	Frequency (MHz)	EIRP Limit (dBm)
Collocated transmitters ^a	WLAN	2400–2500	25
		5150–5850	27
	WiMAX	2300–2400	25
		2500–2700	25
		3300–3800	25
	BT	2400–2500	15

a. Valid collocated transmitter combinations: WLAN+BT; WiMAX+BT.
(WLAN+WiMAX+BT is not permitted.)

5. A label must be affixed to the outside of the end product into which the AirPrime RC7611 is incorporated, with a statement similar to the following:
This device contains FCC ID: N7NRC76B / IC: 2417C-RC76B
6. A user manual with the end product must clearly indicate the operating requirements and conditions that must be observed to ensure compliance with current FCC/IC RF exposure guidelines.

The end product with an embedded AirPrime RC7611 may also need to pass the FCC Part 15 unintentional emission testing requirements and be properly authorized per FCC Part 15.

Note: If this module is intended for use in a portable device, you are responsible for separate approval to satisfy the SAR requirements of FCC Part 2.1093.

Industry Canada Statement

This device complies with Industry Canada license-exempt RSS standard(s). Operation is subject to the following two conditions:

- (1) this device may not cause interference, and
- (2) this device must accept any interference, including interference that may cause undesired operation of the device.

This module is intended for OEM integrator. The OEM integrator is responsible for the compliance to all the rules that apply to the product into which this certified RF module is integrated. Additional testing and certification may be necessary when multiple modules are used.

This equipment complies with IC RSS-102 radiation exposure limits set forth for an uncontrolled environment. This equipment should be installed and operated with minimum distance 20 cm between the radiator and your body.

Le présent appareil est conforme aux CNR d'Industrie Canada applicables aux appareils radio exempts de licence. L'exploitation est autorisée aux deux conditions suivantes :

- (1) l'appareil ne doit pas produire de brouillage, et
- (2) l'utilisateur de l'appareil doit accepter tout brouillage radioélectrique subi, même si le brouillage est susceptible d'en compromettre le fonctionnement.

L'intégrateur OEM doit être conscient de ne pas fournir des informations à l'utilisateur final quant à la façon d'installer ou de supprimer ce module RF dans le manuel de l'utilisateur du produit final qui intègre ce module. Le manuel de l'utilisateur final doit inclure toutes les informations réglementaires requises et avertissements comme indiqué dans ce manuel.

Cet équipement est conforme aux limites d'exposition aux rayonnements IC établies pour un environnement non contrôlé. Cet équipement doit être installé et utilisé avec un minimum de 20 cm de distance entre la source de rayonnement et votre corps.