

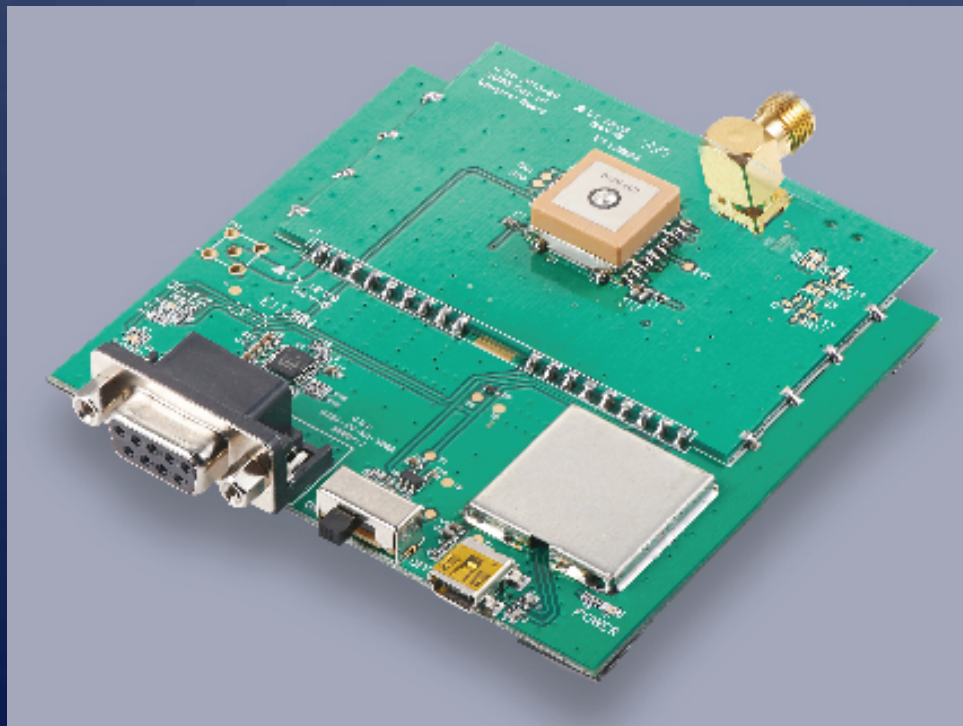

GlobalTop Technology Inc.

EV-Kit User Manual (MT3333 series)

Revision: A04



This document is the exclusive property of GlobalTop Tech Inc. and should not be distributed, reproduced, into any other format without prior permission of GlobalTop Tech Inc. Specifications subject to change without prior notice.

Copyright © 2016 GlobalTop Technology Inc. All Rights Reserved.

No.16 Nan-ke 9th Rd, Science-Based Industrial Park, Tainan, 741, Taiwan, R.O.C.

Tel: +886-6-5051268 / Fax: +886-6-5053381 / Email: sales@gtop-tech.com / Web: www.gtop-tech.com

Version History

Title:		EV-Kit User Manual(MT3333 series)	
Subtitle:		GNSS Module	
Doc Type:		Datasheet	
Revision	Date	Author	Description
A00	2013-03-19	Allen	Preliminary
A01	2013-09-02	Dylan	Add Gms-g6 、Gms-b6
A02	2014-01-13	Delano	Modify web-side link for software tool of GPS viewer
A03	2015-07-10	Jenhsiang	Adding Gmm-3301
A04	2016-11-02	Archie Lin	Modifying the sections 4.2 & 4.3 Logo changed to new version

Table of Contents

Version History	2
Table of Contents	3
Caution	4
Packing Contents	5
1. Introduction	6
2. Board Description	8
2.1 Hardware overview:.....	8
3. Operating Instruction	13
3.1 Function Testing	13
3.2 Application for the various RF reception.....	14
4. Software Usage	15
4.1 System requirement	15
4.2 USB Driver and GPS viewer.....	15
From Silicon Labs Web-side (CP210x USB to UART Bridge VCP Drivers)錯誤! 尚未定義書籤。	
4.3 Installing USB Driver and Microsoft Framework.....	16
5. RTCM Usage	20
5.1 RTCM hardware setting	20
5.2 RTCM software setting.....	21
6. Trouble-shooting	23
6.1 Problems with Setup.....	23
6.2 About Poor GNSS Signal.....	24



Caution

- Global navigation satellite system (GNSS) includes GPS+GLONASS and BeiDou GPS+Beidou-2(COMPASS).
 - ✦ GPS was established by the US Ministry of National Defense.
 - ✦ GLONASS was established by Russian Aerospace Defense Forces and is used in Russia.
 - ✦ Beidou-2 system, also known as “Compass”, has been commercially operational since the end of 2012. It is currently a constellation of 16 satellites ultimately 35 providing worldwide positioning, navigation and timing services to the Asia-Pacific region.

Each country is responsible for the preciseness and maintenance of the system. Any changes they have implemented to the system in the future may enhance or deteriorate the effectiveness and performance of the received GNSS data.

- GNSS signal may be cut off or become seriously weakened if you operate EV-kit inside any infrastructures such as buildings, tunnels, or nearby any huge objects and/or obstruction. That signal being cut off does not mean the EV-kit is malfunctioned; it will operate properly again once it receives clear GNSS signals (works best under open sky).

Packing Contents

- User Manual / Software Application Program
 - CP210X USB Bridge VCP driver
 - GPS Viewer tool with user manual
 - EV-Kit user manual

Note: These items will be delivered by E-mail. Please contact your dealer for the items for more information.

- USB Cable
- EV-Kit with Main Board 、GNSS Module Board
- External Antenna (**module : Gmm-g3, Gmm-3301**)

1. Introduction

The main purpose of this EV-Kit is to simplify the evaluation process for GNSS modules and to help testers operate our products with convenience and ease.

This device can communicate with computer devices via USB cable, and it must be used in conjunction with the software “GPS Viewer”, for users to record all GNSS module data such as satellites’ status, time-to-first-fix (TTFF), date and time.

If evaluation of RTCM function is desired, the tester can refer to GPS Viewer and see how to connect GNSS simulator with the e EV-kit via RS232 (DB-9 Connector).

The EV-Kit has 4 series based on the various modules. Please refer to the list below:

With External Antenna (series 1): Gmm-g3 、 Gmm-3301



Gmm-g3



Gmm-3301

Built-in Patch Antenna (series 2): Gms-g9



Built-in chip antenna (series 3): Gms-g6a



Built-in chip antenna (series 4): Gms-g6 、 Gms-b6(Common board)

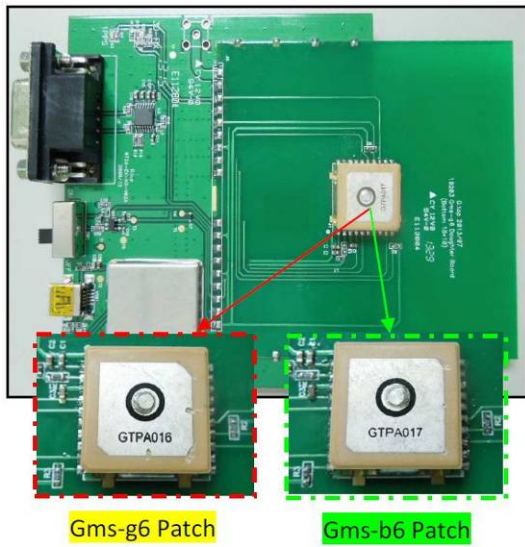

2. Board Description

2.1 Hardware overview:

Please refer to the figures below:

Compatible Models: (Series 1) Gmm-g3

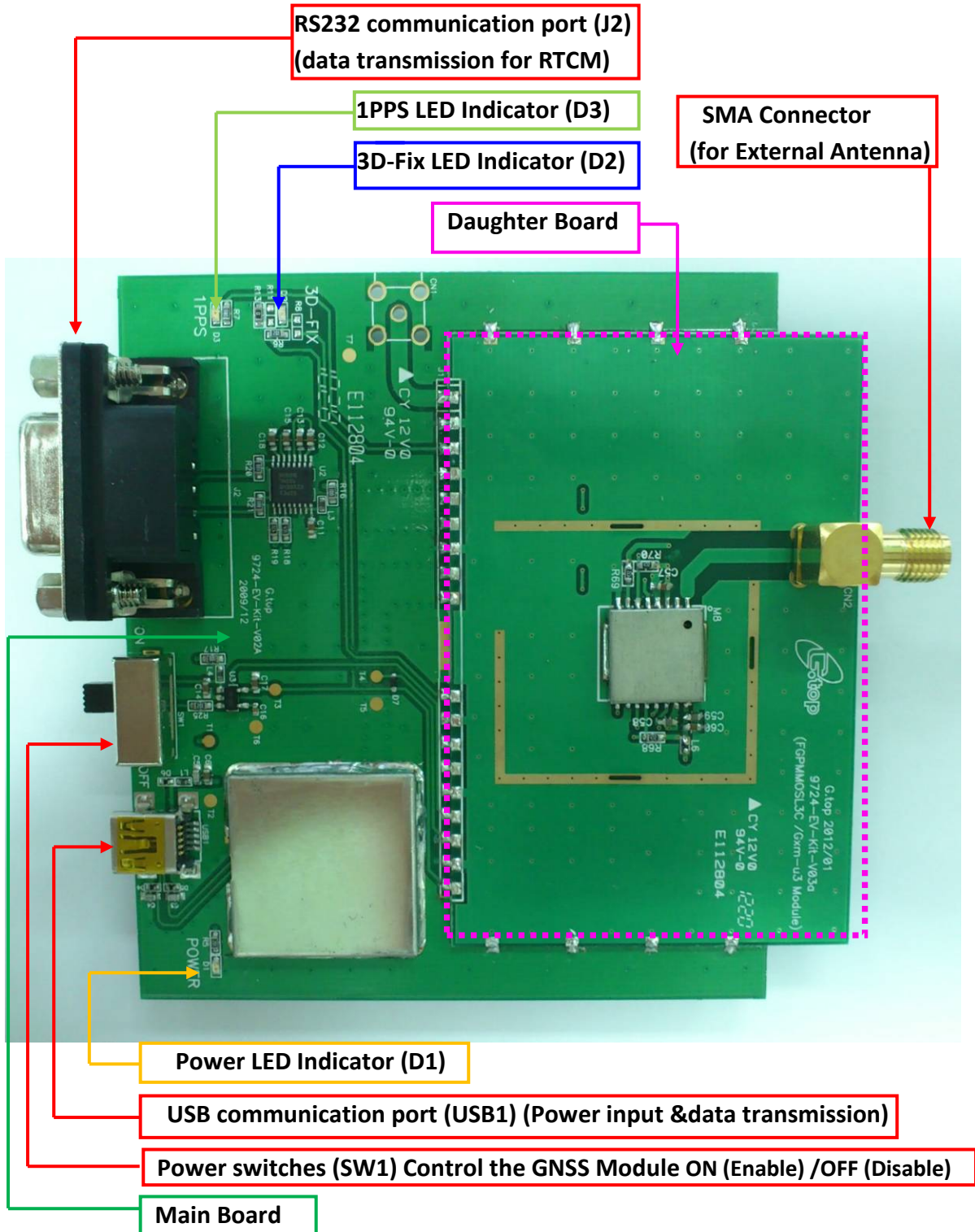

Compatible Models: (Series 1) Gmm-3301

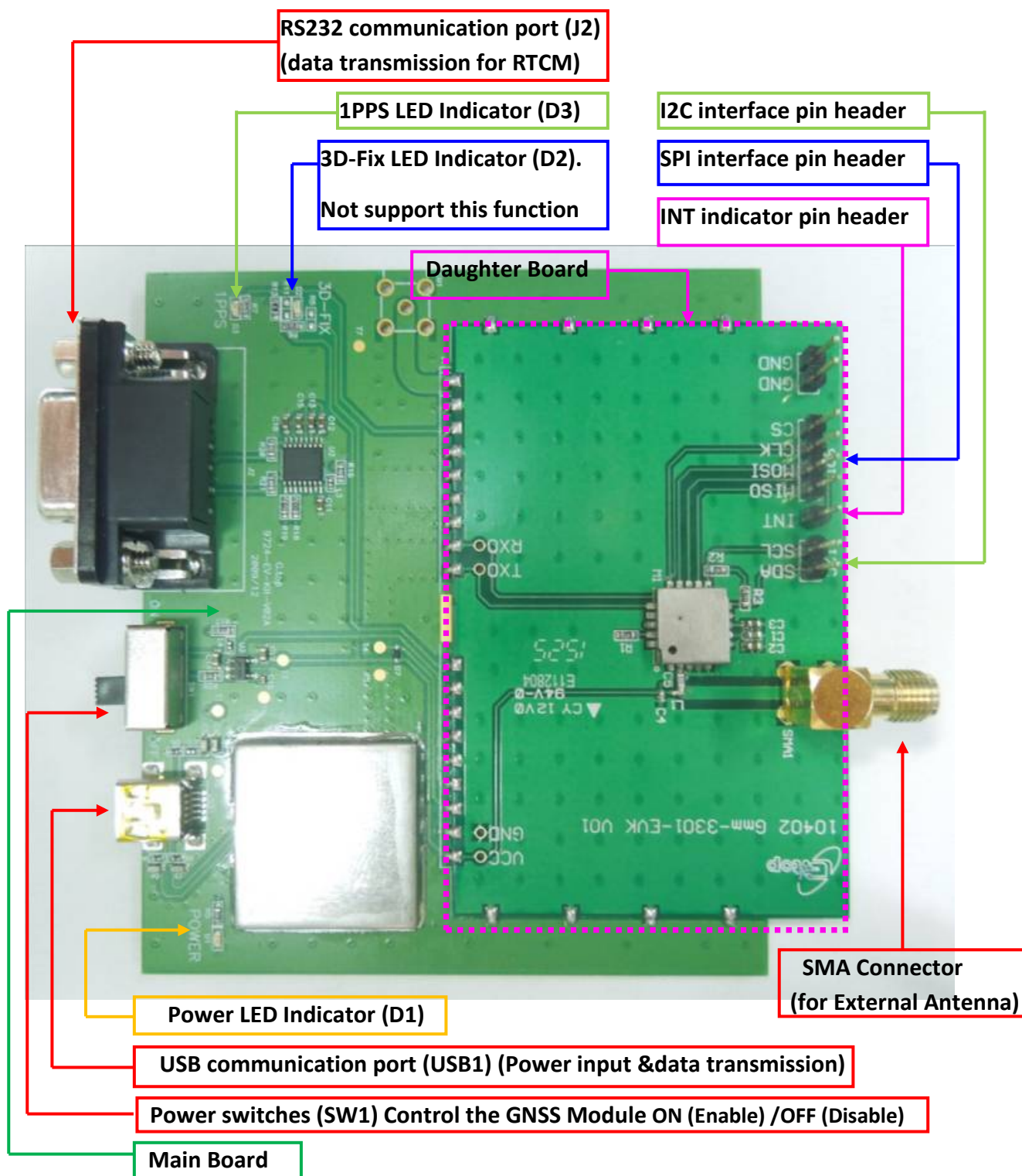

Compatible Model: (Series 2) Gms-g9

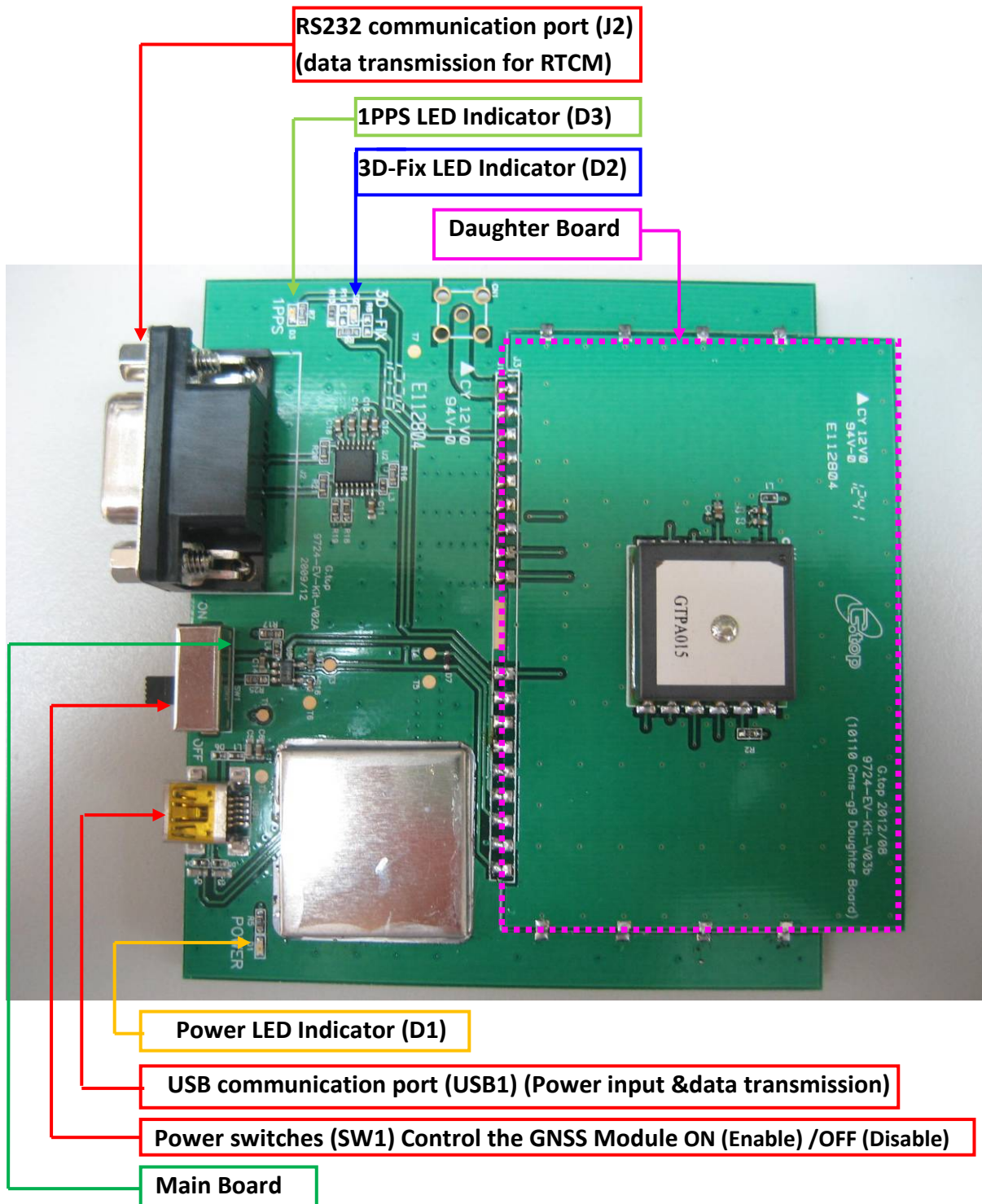

Compatible Model: (series 3) Gms-g6a

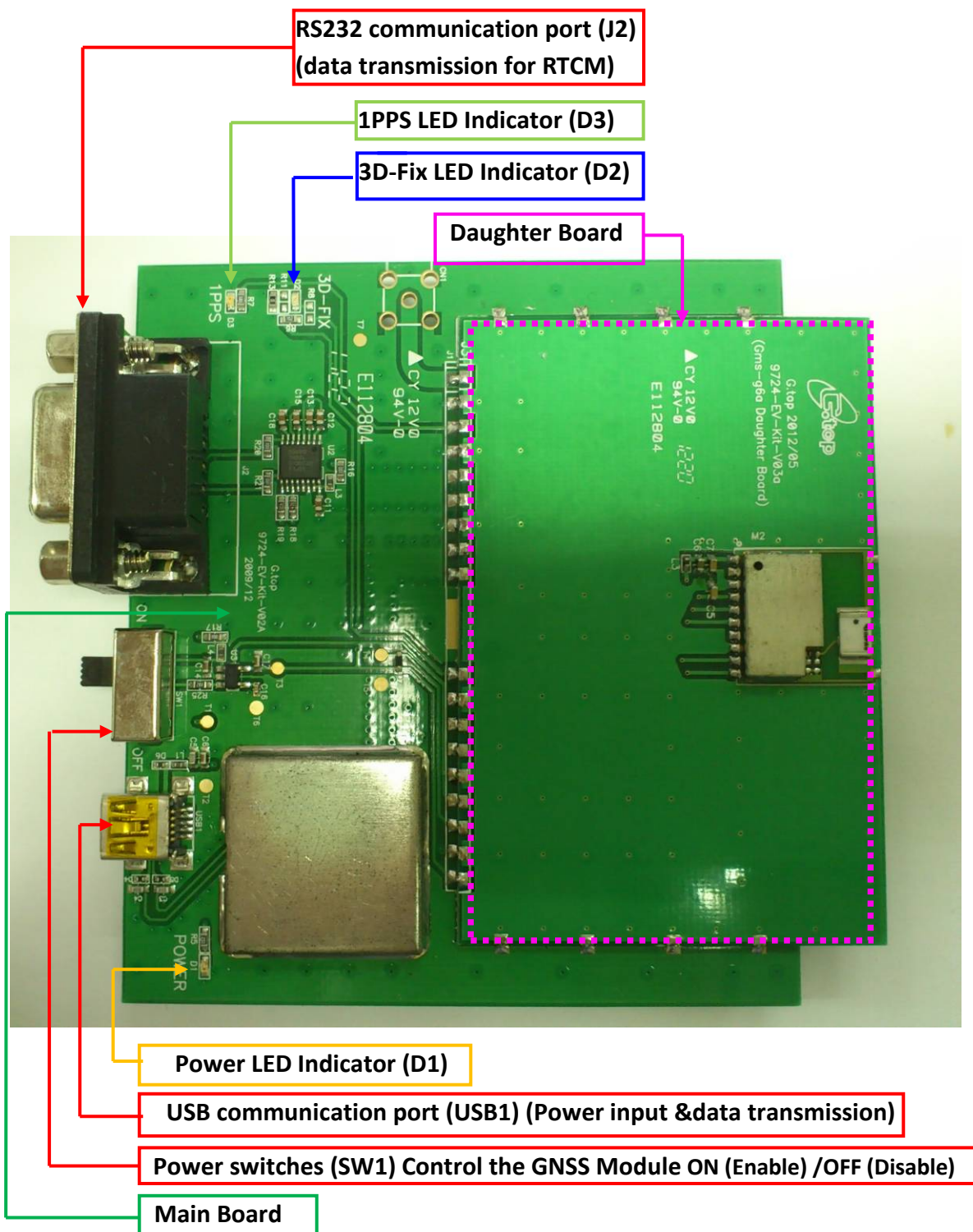

Compatible Model: (series 4)→Gms-g6 、 Gms-b6(Common board)

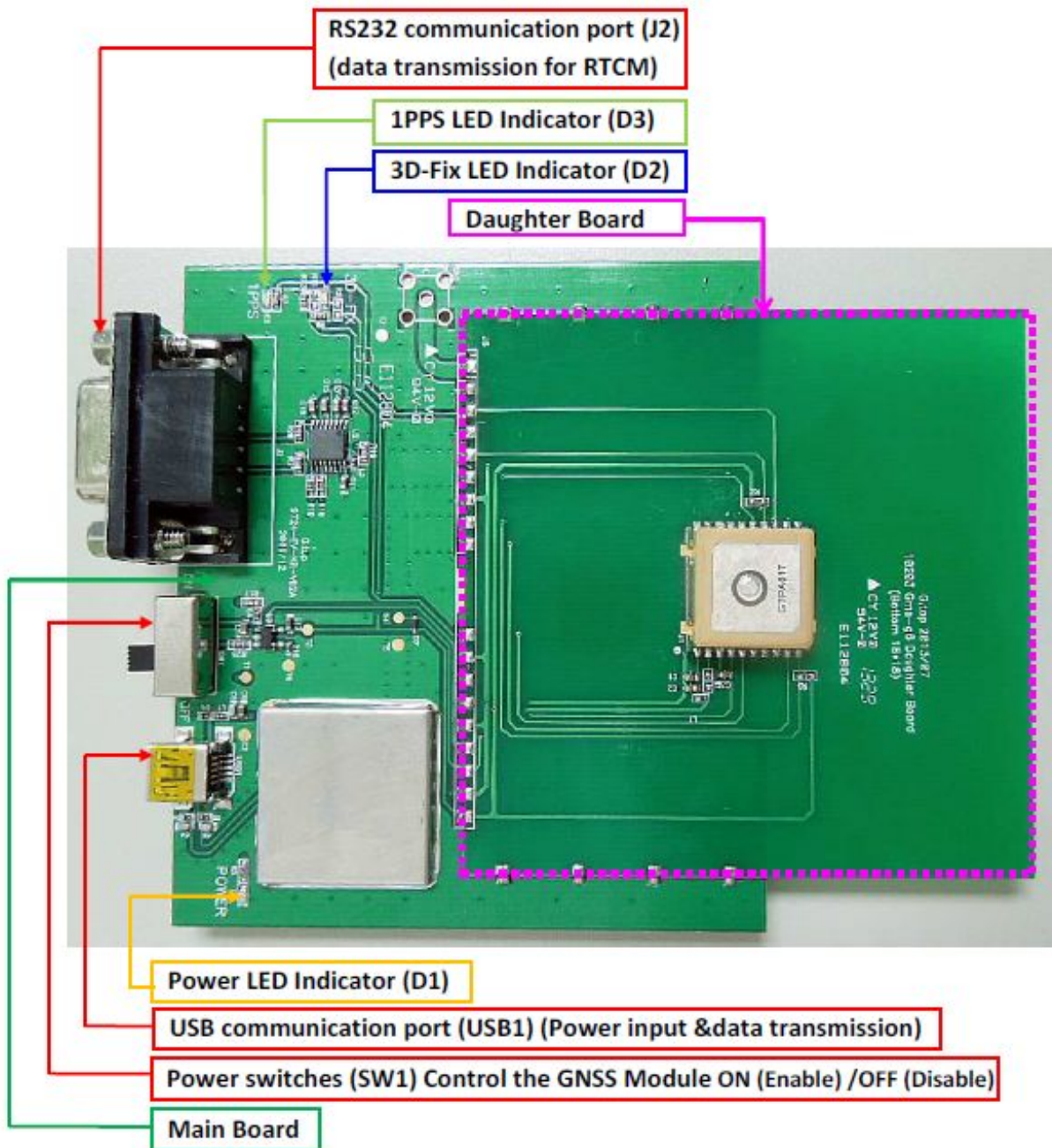

3. Operating Instruction

3.1 Function Testing

➤ Preparation for the power and data communication

Compatible Model: All series

Step 1. Connect USB cable to the EV-kit and to the PC :

- The USB cable supplies power for the EV-Kit, and transmits data between EV-kit & PC
- * Make sure the Power LED Indicator (D1) is lighted on.

Step 2. Toggle the switch (SW1) from right to left for power on GNSS module:

- Toggle the switch to the left for the power supplying on GNSS Module. Please refer to the figure below.

(1.) Once the Power LED Indicator(D1) is on and switch(SW1) is on, the initial state will be the following:

- 3D Fix LED Indicator (D2) blinks (blue light).
- 1PPS LED Indicator (D3) is off (green light).

(2.) Once the module is in the status of FIX:

- 3D Fix LED Indicator (D2) is off.
- 1PPS LED Indicator (D3) blinks.

- The status of 3D fix and 1PPS can be re-defined. Please contact GlobalTop for this customization service.

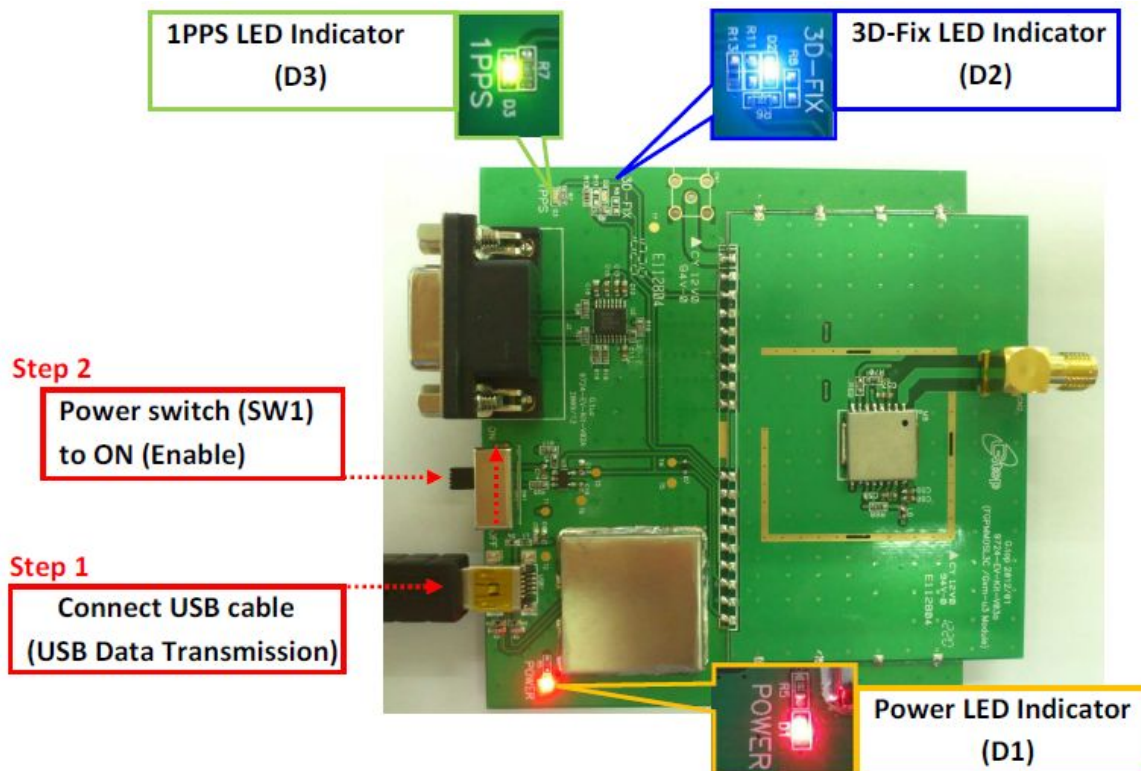

3.2 Application for the various RF reception

a. Attaching external antenna with GNSS modules on EV-kits:

Compatible Models: (series1) Gmm-g3、 Gmm-3301

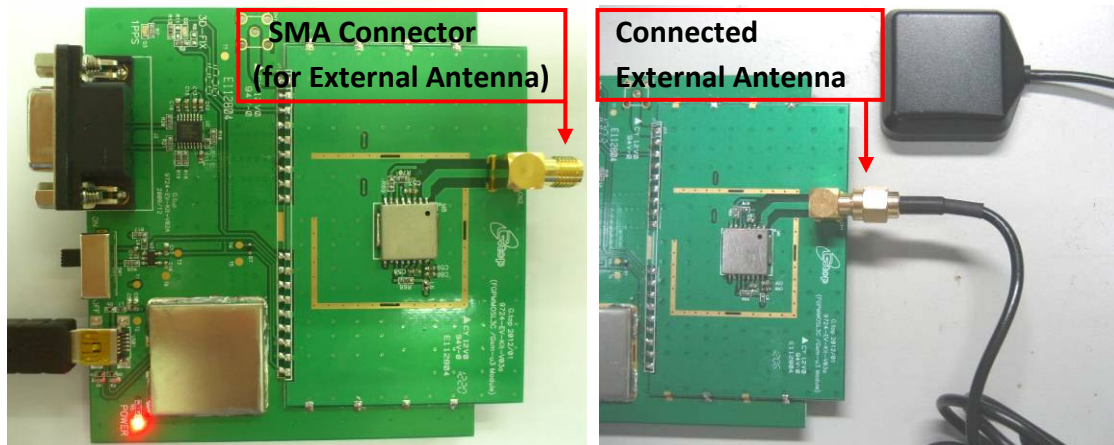

b. Patch Antenna Module

Compatible Model: (Series 2) Gms-g9

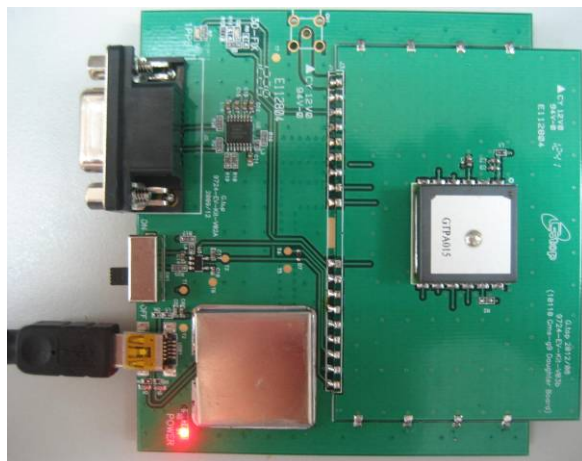

c. Chip Antenna module

Compatible Model: (Series 3) Gms-g6a



d. Patch Antenna Module.

Compatible Models: (Series 4)_Gms-g6、 Gms-b6(Common board)

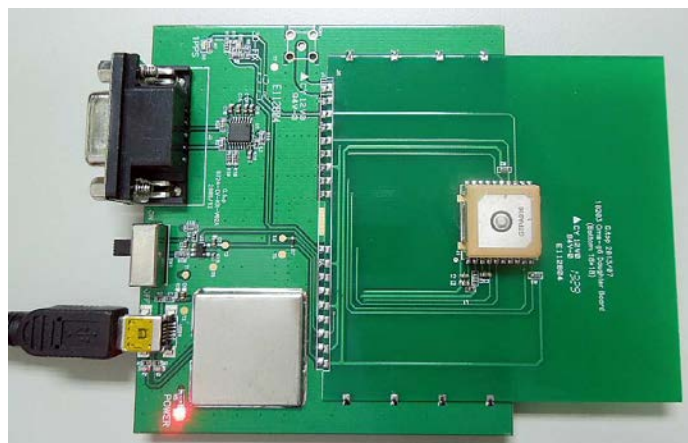

4. Software Usage

4.1 System requirement

PC : IBM, Pentium or above or compatible PC ◦

Operation system : Windows 7/XP/2003/Vista

USB driver: CP210xVCPInstaller.zip

GPS viewer: GPS viewer.exe

4.2 USB Driver and GPS viewer



Please check whether you have the correct USB driver before you proceed to next step.
Without correct driver, the EV-Kit will not function.

➤ You will need **EV-kit USB Driver (CP210xVCP)** and **GPS Viewer.exe** to operate the EV-kit.

Please contact your distributor or Gtop sales (sales@gtop-tech.com) for these 2 files.

4.3 Installing USB Driver and Microsoft Framework

- Double click [**CP210x_VCP_Win.exe**] to begin driver installation as the figure shows below.

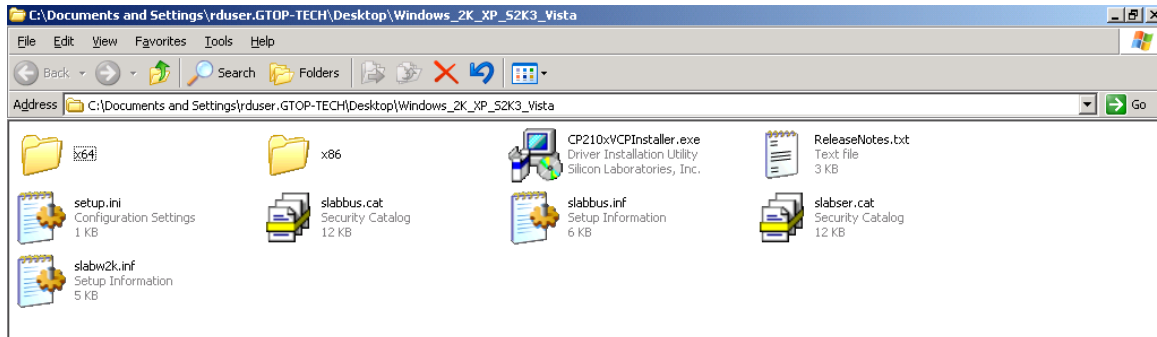

- Click [**Install**]

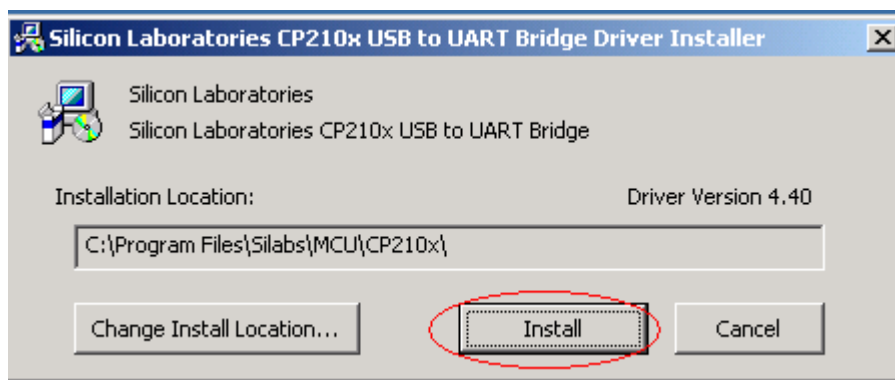

- After the installation is complete, you may need to restart your computer. Please follow the instructions on screen to restart your computer.
- After the computer restarted, right click on **<My Computer>**, and select **<Manage>**

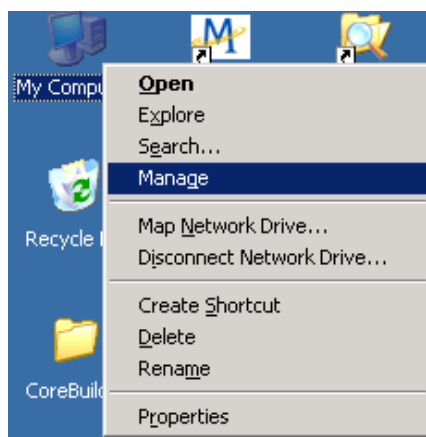

- Left click <Device Manager>, and select <Ports (COM & LPT)>. Check to see if a device named <Silicon Labs CP210x USB to UART Bridge (COM#)> is present. If so, EV-Kit is now setup and ready for use. Please refer to the figure shows below.

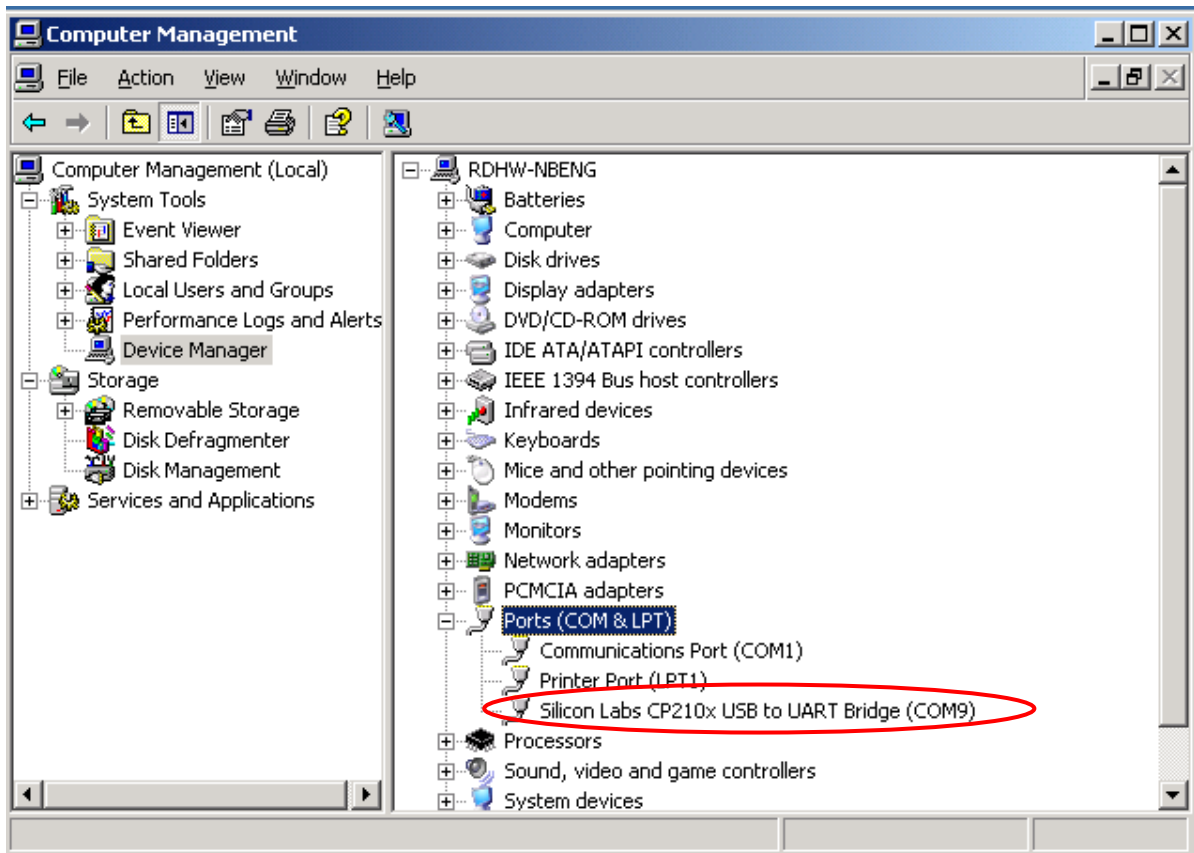

#" represents the virtual COM Port number generated for the USB connection to EV-Kit. This generated COM Port value must match the COM Port value in the program setting for the application to establish proper communication with EV-Kit.

After complete installation, please proceed to [4.4 GPS Viewer Software usage] .

Note: for using GPS Viewer, Microsoft Framework version 3.5 or later is needed.

4.4 Using GPS Viewer

- **Open GPS viewer software** (for using GPS Viewer, Microsoft Framework version 3.5 or later is required).
- Double click < **GPS Viewer.exe**> to start the application.
- Select corresponding & appropriate values for <**COM Port**>, <**Baud Rate**> and <**Chip**>, then click <**Open**>.

Please refer to figure shown below:

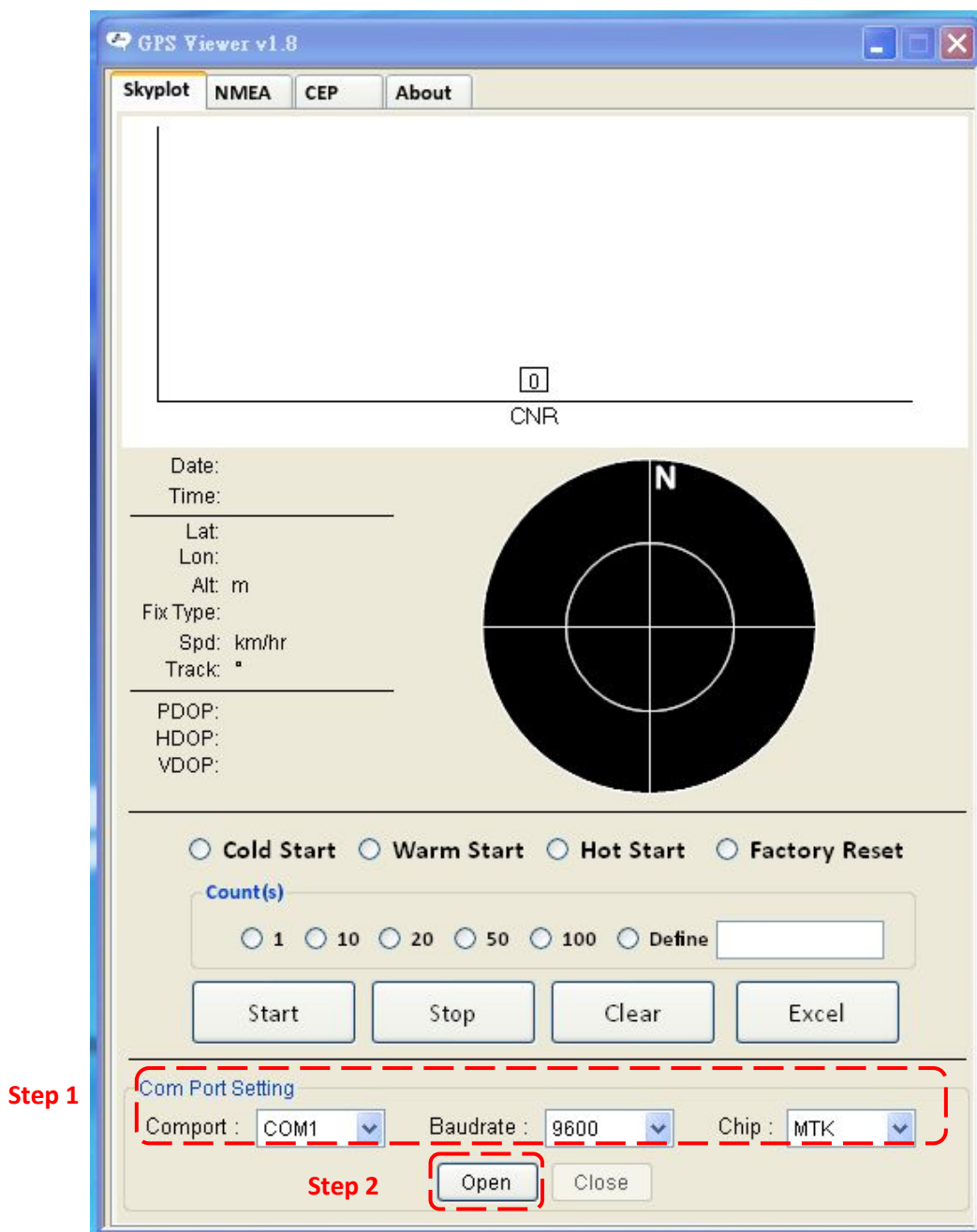

➤ After <Open> is clicked, the following screen will show up:

```

$GPVTG,0.00,T,,M,0.00,N,0.00,K,N*32
$PMTKLOG,0,1,a,31,15,0,0,1,0,0*11
$PMTK001,183,3*3A
$PMTK869,2,1*36
$GPGGA,0.00,030.304,,,,,0,0,,M,,*4C
$GPGSA,A,1,,,,,,,,,,,,,*1E
$GPRMC,0.00,030.304,V,,,,,0.00,0.00,060180,,,N*46
$GPVTG,0.00,T,,M,0.00,N,0.00,K,N*32
$PMTKLOG,0,1,a,31,15,0,0,1,0,0*11
$PMTK001,183,3*3A
$PMTK869,2,1*36
$GPGGA,0.00,031.304,,,,,0,0,,M,,*4D
$GPGSA,A,1,,,,,,,,,,,,,*1E
$GPRMC,0.00,031.304,V,,,,,0.00,0.00,060180,,,N*47
    
```

5. RTCM Usage

5.1 RTCM hardware setting

Compatible Models: Gmm-g3、Gms-g9、Gms-g6、Gms-b6

Note: Gmm-3301 also supports this function but that needs to be setup in firmware.

➤ Getting RTCM data via RS232port :

- Connect the RS232 cable to GNSS simulator and EV-Kit. The RS232 cable is connected to EV-Kit RS232 port (J2) and to GNSS simulator or other RTCM server as the figures shown below.

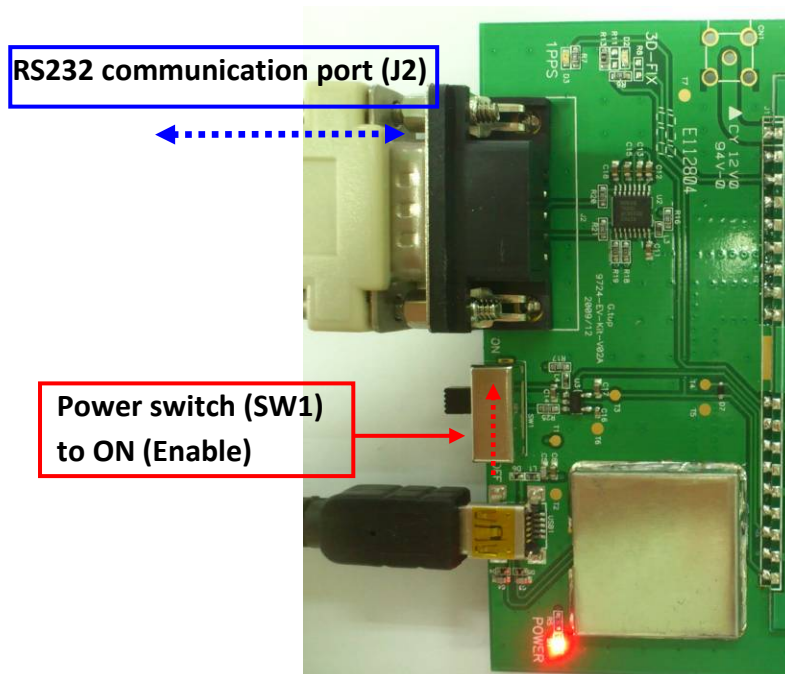

GNSS Simulator Hardware set up as below:

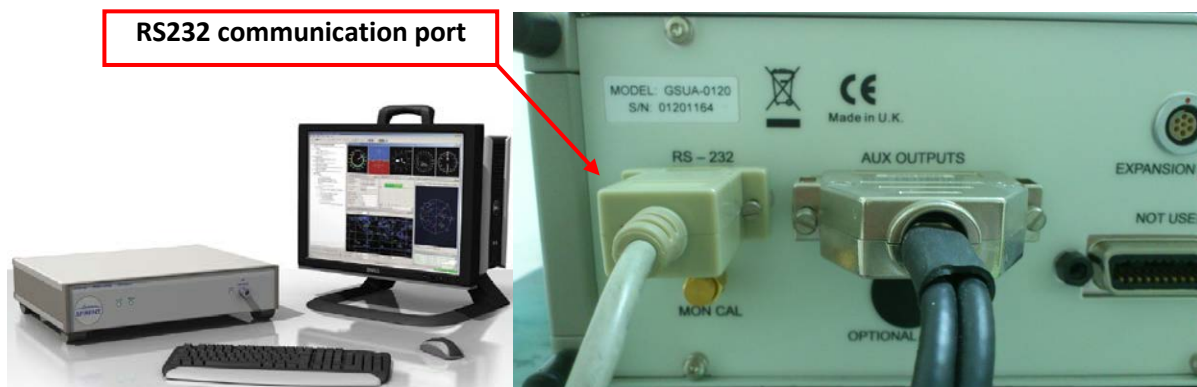

5.2 RTCM software setting

GNSS Simulator software set up:

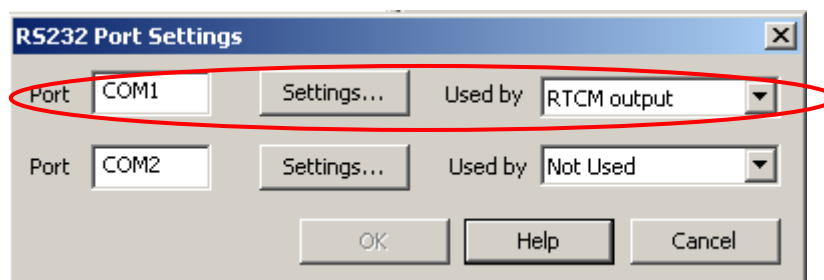
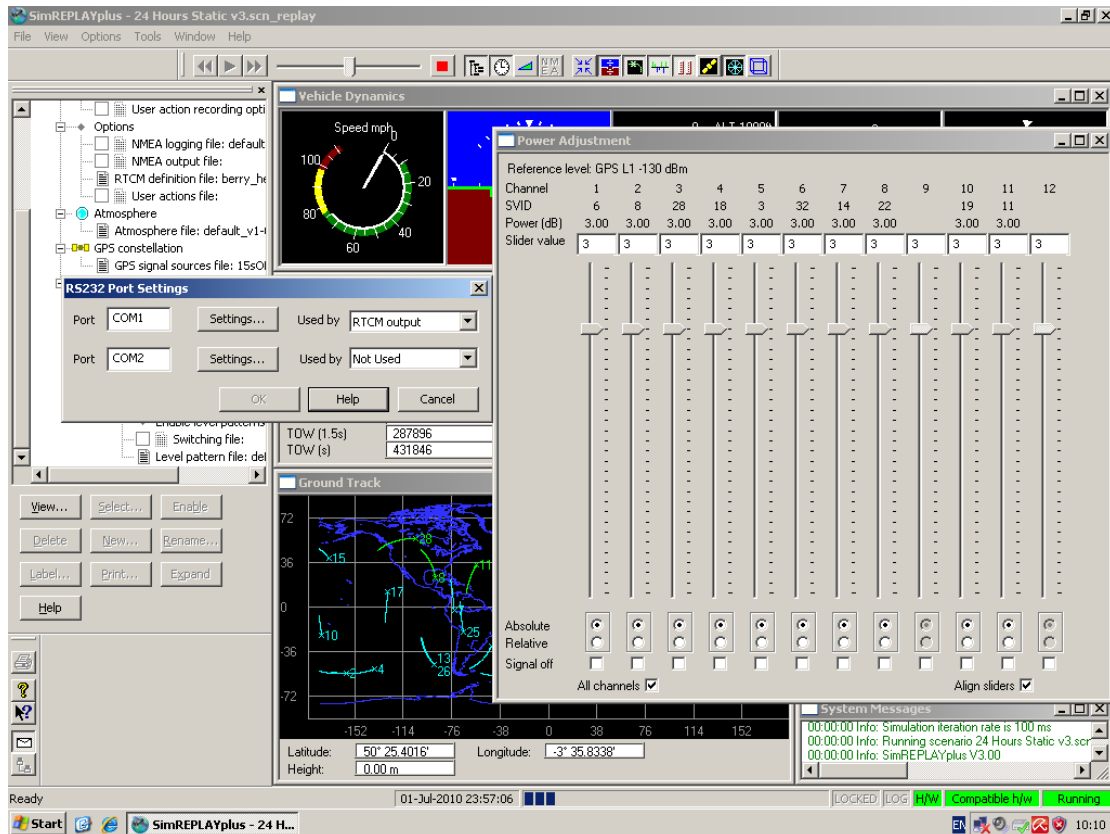

(If RTCM data are acquired from third party, then please contact the third party for all necessary information).

- In GPS viewer, functions of RTCM for GNSS Module can be checked when RTCM is enabled.
- The default setting of RTCM in GlobalTop's GNSS modules is disabled. If customer needs it enabled, please check firmware feasibility or contact GlobalTop.

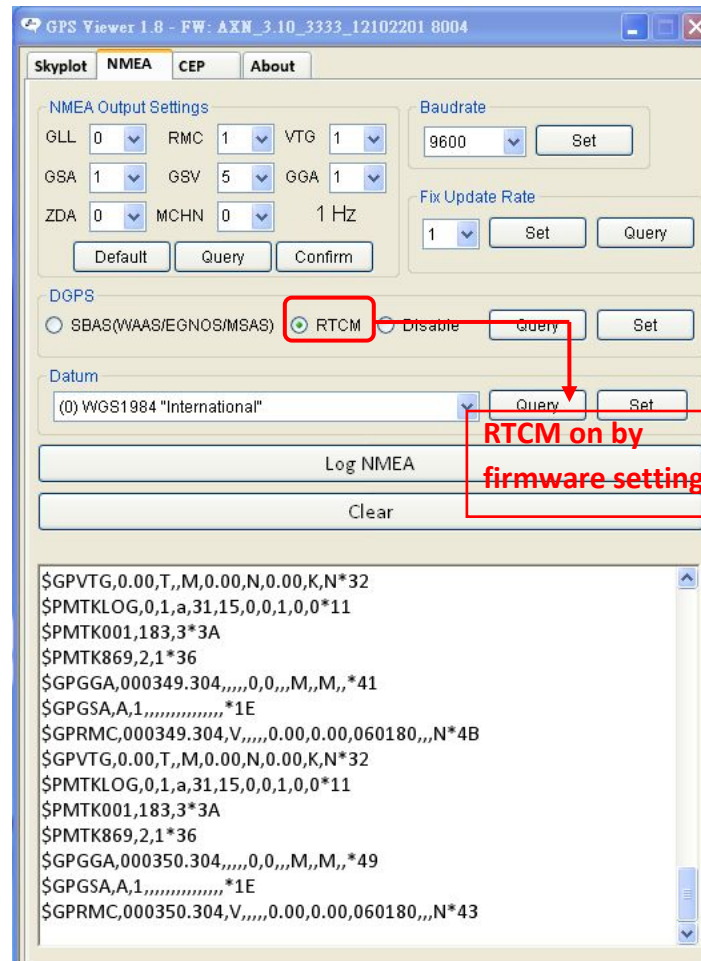

- Check NMEA output sentences and see if RTCM is enabled. Please see the example below:

\$GPRMC,064951.000,A,2307.1256,N,12016.4438,E,0.03,165.48,260406,3.05,W,D*2C

\$GPVTG,165.48,T,,M,0.03,N,0.06,K,D*37

D = Differential mode(DGPS)

6. Trouble-shooting

6.1 Problems with Setup

Problem	Possible Cause	Trouble shooting
Cannot find GNSS device	USB was not setup properly	Check to see if EV-Kit was setup properly, and make sure that the device is receiving enough power through the USB cable (Red LED should light up continuously).
No NMEA data or GNSS signals	(1) USB was not setup properly. (2) COM Port or Baud rate value is incorrect	(1) Check to see if the USB connector to PC or EV-Kit is connected properly. (2) Double check to see if the proper COM Port and Baud rate value are selected.
Poor GNSS Signal Reception	(1) If it is used inside a vehicle, the anti-sunscreen film on the windshield may interfere and weaken the GNSS signal. (2) The vehicle might be under some area with dense overhead canopy such as forest, buildings, tunnels... etc.	For both problems, the user may apply the external antenna with the EV-Kit, and then place the antenna on top roof of the car to improve signal reception.

Note: if the options of troubleshooting do not solve the problem, please contact us or send it back to us for inspection.

6.2 About Poor GNSS Signal

It is possible to have weak GNSS signal under the following situations:

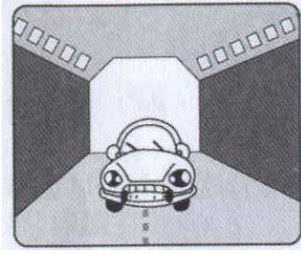

Inside a tunnel, where GNSS signal is blocked.

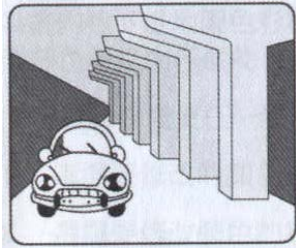

Underneath an infrastructure (like bridge), where GNSS signal is blocked.

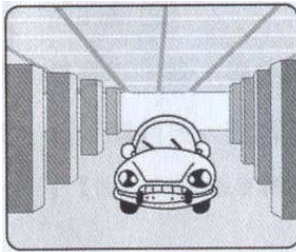

Inside a building, where GNSS signal is blocked.

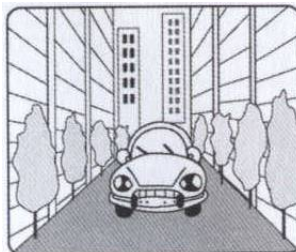

Next to tall buildings, where GNSS signal is weakened.

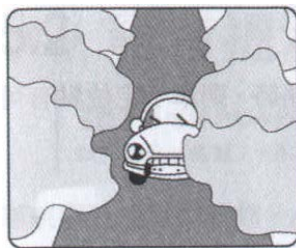

Underneath forests or any other kinds of canopy where GNSS signal is weakened.

- If the EV-Kit is used inside a car which it has anti-sunlight films on the windshield and windows, the GPS signal will be weakened severely, and may result to no GPS reception.
- GNSS satellites are property of United States Army. Sometimes they will tune-down the accuracy for unknown reasons. In such cases, the GNSS position may not be accurate.