



Modules



Product Technical Specification

RC76xx

Important Notice

Information relating to this product and the application or design described herein is believed to be reliable, however such information is provided as a guide only and Semtech assumes no liability for any errors in this document, or for the application or design described herein.

Semtech reserves the right to make changes to the product or this document at any time without notice. Buyers should obtain the latest relevant information before placing orders and should verify that such information is current and complete. Semtech warrants performance of its products to the specifications applicable at the time of sale, and all sales are made in accordance with Semtech's standard terms and conditions of sale.

SEMTECH PRODUCTS ARE NOT DESIGNED, INTENDED, AUTHORIZED OR WARRANTED TO BE SUITABLE FOR USE IN LIFE-SUPPORT APPLICATIONS, DEVICES OR SYSTEMS, OR IN NUCLEAR APPLICATIONS IN WHICH THE FAILURE COULD BE REASONABLY EXPECTED TO RESULT IN PERSONAL INJURY, LOSS OF LIFE OR SEVERE PROPERTY OR ENVIRONMENTAL DAMAGE. INCLUSION OF SEMTECH PRODUCTS IN SUCH APPLICATIONS IS UNDERSTOOD TO BE UNDERTAKEN SOLELY AT THE CUSTOMER'S OWN RISK. Should a customer purchase or use Semtech products for any such unauthorized application, the customer shall indemnify and hold Semtech and its officers, employees, subsidiaries, affiliates, and distributors harmless against all claims, costs damages and attorney fees which could arise.

The Semtech name and logo are registered trademarks of the Semtech Corporation. All other trademarks and trade names mentioned may be marks and names of Semtech or their respective companies. Semtech reserves the right to make changes to, or discontinue any products described in this document without further notice. Semtech makes no warranty, representation or guarantee, express or implied, regarding the suitability of its products for any particular purpose. All rights reserved.

Wireless Communications

Due to the nature of wireless communications, transmission and reception of data can never be guaranteed. Data may be delayed, corrupted (i.e., have errors) or be totally lost. The Semtech product should not be used in situations where failure to transmit or receive data could result in damage of any kind to the user or any other party, including but not limited to personal injury, death, or loss of property. Semtech accepts no responsibility for damages of any kind resulting from delays or errors in data transmitted or received using the Semtech product, or for failure of the Semtech product to transmit or receive such data.

Safety

Do not operate the Semtech product in areas where blasting is in progress, where explosive atmospheres may be present, near medical equipment, near life support equipment, or near any equipment which may be susceptible to any form of radio interference. In such areas, the Semtech product should be powered off.

Qualcomm Licenses

Semtech's cellular modules are sold subject to certain notices and restrictions regarding patent licenses from Qualcomm Incorporated. These notices and restrictions are available at www.sierrawireless.com/qualcomm-notices.

Sierra Wireless

Semtech Corporation purchased Sierra Wireless in January 2023. The Sierra Wireless brand is gradually being phased out. During the phase-out period, references to both “Semtech” and “Sierra Wireless” may appear in product documentation.

Contact Information

Sales information and technical support, including warranty and returns	Web: sierrawireless.com/company/contact-us Global toll-free number: 1-877-687-7795 6:00 am to 5:00 pm PST
Corporate and product information	Web: sierrawireless.com

Revision History

Revision Number	Release Date	Changes
1.0	November 08, 2019	Creation
2.0	January 03, 2020	Baseband and other software-related modifications
2.1	January 22, 2020	<ul style="list-style-type: none"> ▪ Modify the current consumption from 15uA to TBD ▪ Added FCC ID
2.2	February 05, 2020	<ul style="list-style-type: none"> ▪ Updated Transmit Band and Receive Band columns in Table1-3 ▪ Removed SDIO information ▪ Changed PSM mode values to TBD on Table 3-9
3.0	June 22, 2020	Updates on Functional Specifications, Technical Specifications, Interface Details, Routing Constraints and Recommendations, Pinout, and Acronyms
3.1	July 06, 2020	Minor edits on Table1-3
3.2	July 07, 2020	Updated Figure 3-4 and Figure 3-5
4.0	September 01, 2020	<ul style="list-style-type: none"> ▪ Updates on Functional Specifications, Technical Specifications, Interface Details, Routing Constraints and Recommendations, Pad, and Acronyms ▪ Added RC7630 specifications ▪ Added Japan Regulatory approval
5.0	November 04, 2020	<ul style="list-style-type: none"> ▪ Updates on Functional Specifications, Technical Specifications, Interface Details, Routing Constraints and Recommendations, Pad, and Acronyms ▪ Added Industry Canada Statement
5.1	November 05, 2020	<ul style="list-style-type: none"> ▪ Additional minor edits
6.0	January 12, 2021	<ul style="list-style-type: none"> ▪ Added internal devic18e frequencies ▪ Additional minor edits

Revision Number	Release Date	Changes
6.1	February 23, 2021	<ul style="list-style-type: none"> ▪ Updated PCM mode timings
6.2	February 24, 2021	<ul style="list-style-type: none"> ▪ Removed information about GSM support for RC7630 series
7.0	May 07, 2021	<ul style="list-style-type: none"> ▪ Added new note under Introduction
8.0	September 22, 2021	<ul style="list-style-type: none"> ▪ Updated Table 3-11, Updated section 9.5.1, Added new note under VGPIO, and other minor edits
9.0	April 20, 2022	<ul style="list-style-type: none"> ▪ Added add RC7612, RC7612-1 (Limited Availability) ▪ Added Support Band tables for RC7612, RC7612-1
10.0	July 2022	<ul style="list-style-type: none"> ▪ Updates on Technical Specifications
11.0	August 2022	<ul style="list-style-type: none"> ▪ Added back the following sections: <ul style="list-style-type: none"> ▪ Software and Tools ▪ Reliability Specification ▪ Customization ▪ Testing ▪ References ▪ Abbreviations
12	January 2023	<ul style="list-style-type: none"> ▪ Updated Figure 4-2 ▪ Added product markings for NCC, JPA/JRF and KCC on Product Marking
13	June 2023	<ul style="list-style-type: none"> ▪ Updated footnote e on Table 4-6 ▪ Updated WAKE_ON_WWAN description ▪ Updated Figure 4-6 ▪ Modified assertion time for POWER_ON_N ▪ Modified assertion time for POWER_ON_N in Power State Transitions
14	September 2024	<ul style="list-style-type: none"> ▪ Updated Table 3-1 ▪ Updated Under-Voltage Lockout (UVLO) ▪ Updated POWER_ON_N ▪ Updated Reset Signals (RESET_IN_N and RESET_OUT_N) ▪ Updated the document format to the new Semtech template ▪ Updated Approvals chapter to Regulatory Compliance and Industry Certifications ▪ Updated Important Notes and added a note under Power Saving Mode (PSM). ▪ Added footnote b to Table 4-3 ▪ Added footnote l to Table 10-1 ▪ Added note under UART. ▪ Added note under UIM Interface.

Revision Number	Release Date	Changes
15	December 2024	<ul style="list-style-type: none"> ▪ Added Table 1-5: RC7630J band configuration ▪ Updated Table 1-1: Supported Networks and Voice Capability for RC7630J ▪ Added RC7630J in Figure 2-1: Architecture Overview ▪ Updated 2.2 Telecom Features ▪ Added RC7630J in Table 3-14: Supported RF Band ▪ Added Table 3-18: RC7630J Conducted Tx Max Output Power Tolerances—LTE ▪ Added Table 3-22: RC7630J Conducted Rx Sensitivity—LTE Bands ▪ Added RC7630J in 4.7.2 eSIM / UIM2 Interface ▪ Updated Table 10-1: Pin Definitions ▪ Added Table 12-7: Test Settings—RC7630J LTE Transmission Path ▪ Added Table 12-14: Test Settings — RC7630J LTE Receive Path ▪ Updated Chapter 9 as Legal Information and added RC7630J ▪ Added RC7630J under Japan Radio and Telecom Approval (pending final regulatory approval)
16	March 2025	<ul style="list-style-type: none"> ▪ Updated 8. Reliability Specification
17	August 2025	<ul style="list-style-type: none"> ▪ Updated Figure 4-2: Signal Timing (POWER_ON_N, and USB Enumeration) ▪ Added RC7611D and RC7611D-1
18	October 2025	<ul style="list-style-type: none"> ▪ Updated Figure 4-1: POWER_ON_N ▪ Updated 6.5 Product Marking

Contents

- Important Notice 2
- Wireless Communications..... 2
- Safety..... 2
- Qualcomm Licenses 2
- Sierra Wireless 3
- Contact Information 3
- Revision History 3

- 1: Introduction 12**
 - 1.1 General Features..... 12
 - 1.2 Interfaces 16
 - 1.3 Common Flexible Form Factor (CF3)..... 16
 - 1.4 Physical Dimensions and Connection Interface..... 16

- 2: Functional Specifications 19**
 - 2.1 Architecture 19
 - 2.2 Telecom Features 20
 - 2.2.1 Network Technology Specifications 21
 - 2.2.2 Modem Specifications..... 25
 - 2.3 Multi-Core Processing Capabilities 25

- 3: Technical Specifications 26**
 - 3.1 Environmental 26
 - 3.2 Power Supply Ratings 26
 - 3.2.1 Under-Voltage Lockout (UVLO) 28
 - 3.2.2 Sudden Power Loss 29
 - 3.2.3 Power Consumption States..... 29
 - 3.2.4 Power Saving Mode (PSM) 32
 - 3.2.5 Active State to PSM Transition..... 34
 - 3.2.6 Extended Discontinuous Reception (eDRX) 34
 - 3.2.7 Current Consumption 36
 - 3.3 RF..... 43

3.3.1 Supported RF Bands	44
3.3.2 LTE RF Interface	45
3.3.3 GSM / GPRS / EDGE RF Interface	49
3.3.4 WCDMA RF Interface.....	50
3.3.5 WWAN Antenna Interface	51
3.4 GNSS.....	54
3.4.1 Characteristics.....	55
3.4.2 GNSS Antenna Interface.....	55
3.4.3 Antenna Recommendations	56
3.5 Electrical Specifications.....	57
3.5.1 Absolute Maximum Ratings	57
3.5.2 Digital I/O Characteristics	58
3.5.3 Internal Devices.....	61
3.6 Processing.....	61
3.6.1 Application Core	61
3.6.2 Embedded Memory	62
3.6.3 Recovery Mechanism	64
3.6.4 Secure Boot / Secure Debug.....	64
3.7 Mechanical Drawing.....	65
3.8 Mechanical Specifications	66
4: Interfaces Specifications.....	67
4.1 POWER_ON_N	67
4.1.1 Power-up Sequence	68
4.1.2 Software-Initiated Power Down	69
4.2 Emergency Power Off	69
4.3 POWER_ON_N, RESET_IN_N, AT!POWERDOWN Use Cases	70
4.4 Tx Power Control.....	70
4.5 USB.....	70
4.6 UART.....	71
4.7 UIM Interface	73
4.7.1 External UIM1 Interface	73
4.7.2 eSIM / UIM2 Interface.....	74

4.7.3 External SIM Switch Configuration	75
4.8 General Purpose Input / Output	76
4.9 GPIO4	78
4.9.1 SIM Detect	78
4.9.2 General Purpose Input / Output.....	78
4.10 GPIO6	78
4.10.1 SIM Switching.....	78
4.10.2 General Purpose Input / Output	78
4.10.3 RESET_OUT_N.....	79
4.11 Wakeup Interrupt (Sleep State)	79
4.12 Wakeup Events (PSM).....	80
4.13 I2C Interface.....	80
4.13.1 Application	81
4.14 VGPIO	81
4.15 Reset Signals (RESET_IN_N and RESET_OUT_N).....	82
4.16 ADC.....	84
4.17 Digital Audio.....	84
4.17.1 PCM	85
4.17.2 I2S.....	96
4.18 SPI Bus.....	97
4.18.1 Configuration.....	97
4.18.2 Waveforms	97
4.20 TP1 (Boot Pin)	99
4.21 Temperature Monitoring	99
4.22 Test Pins	101
4.23 Antenna Control	102
4.24 Indication Interfaces	103
4.24.1 Tx Activity Indicator (TX_ON).....	103
4.24.2 WWAN_LED_N	104
4.24.3 WAKE_ON_WWAN.....	104
4.24.4 Ring Indicator	104
4.24.5 SAFE_PWR_REMOVE	105

4.25 DR_SYNC	106
4.26 W_DISABLE_N — Wireless Disable	106
5: Routing Constraints and Recommendations	108
5.1 General Rules and Recommendations	108
5.2 Power Supply	108
5.3 Antenna	108
5.3.1 OTA Considerations when Developing Products with an Integrated Antenna.	109
5.4 PCB Layout Recommendations	109
5.4.1 General Design Rules	109
5.4.2 Specific Design Rules to Support TRP Performances	111
5.4.3 Specific Design Rules to Support TIS Performance	112
5.5 PCB Specifications for the Application Board	112
5.6 Recommended PCB Land Pattern	112
5.7 Routing Constraints	112
5.7.1 Power Supply	112
5.7.2 UIM Interface	114
5.7.3 RF Routing Recommendations	114
5.7.4 USB Interface	117
5.8 Thermal Considerations	118
5.9 EMC and ESD Recommendations	118
5.10 Mechanical Integration	119
5.11 Signal Reference Schematics	119
5.11.1 UIM Holder	119
5.11.2 USB	121
6: Software and Tools	122
6.1 Support Tools	122
6.2 SED (Smart Error Detection)	122
6.3 Firmware Upgrade	122
6.4 Operating System Upgrade	122
6.5 Product Marking	123

7: Debug and Assembly Considerations	124
7.1 Testing Assistance Provided by Semtech	124
7.2 Integration Requirements	124
7.3 IOT / Operator	124
7.4 Module Testing Recommendations	124
7.5 Serial Link Access	124
7.6 RF Output Accessibility	125
7.7 USB Debug	125
8: Reliability Specification	126
8.1 Functional / Performance Tests	126
8.2 Aging Tests	126
8.2.1 High Temperature Operating Life Test	126
8.2.2 Humidity Test	126
8.2.3 Thermal Shock Test	126
8.3 Characterization Tests	126
8.3.1 Electrostatic Discharge Test	126
8.3.2 Low Temperature Cold Start Test	127
8.3.3 Electrostatic Discharge Component Test	127
8.3.4 Unprotected Free Fall Drop Test	127
8.3.5 Component Solder Wettability Test	127
9: Legal Information	128
9.1 Regulatory and Industry Approvals/ Certifications	128
9.2 Compliance Acceptance and Certification	128
9.3 Certification Compliance	129
9.3.1 Important Compliance Information for North American Users	129
9.3.2 Japan Radio and Telecom Approval	131
10: Pinout	132
10.1 Pin Configuration	132
10.2 Pin Description	132

- 11: Customization 141**

- 12: Testing 142**
 - 12.1 Certification Testing. 142
 - 12.2 Production Testing. 142
 - 12.3 Functional Production Test 143
 - 12.3.1 Suggested Production Tests. 143
 - 12.3.2 Production Test Procedure 143
 - 12.4 UMTS (WCDMA/GSM) RF Transmission Path Test 145
 - 12.5 LTE RF Transmission Path Test 147
 - 12.6 UMTS (WCDMA/GSM) RF Receive Path Test. 150
 - 12.7 LTE RF Receive Path Test 153
 - 12.8 GNSS RF Receive Path Test. 155

- A: Appendix. 157**
 - A.1 Web Site Support 157
 - A.2 Reference Documents. 157
 - A.3 Abbreviations. 157

1: Introduction

This document defines the high-level product features and illustrates the interfaces for the Semtech RC76xx Embedded Modules. It covers the hardware aspects of the product series, including electrical and mechanical.

Note: Semtech modules are shipped factory-programmed, with industry or mobile operator approved firmware, according to the specific SKU ordered. Periodically, newer firmware versions become available and can include new features, bug fixes, or critical security updates. Semtech strongly recommends that customers establish their own production capability for updating module firmware on their assembled end platform, in the event that a newer firmware must be installed before deployment. Semtech also recommends customers design their products to support post-deployment FOTA upgrades using the AirVantage cloud platform.

1.1 General Features

The Semtech R76xx is an industrial-grade LGA 239-pad embedded module. Its wireless modem provides voice and data connectivity on the networks listed in [Table 1-1](#).

Table 1-1: Supported Networks and Voice Capability

Variant	Network	Network Voice Support	LTE Category
RC7611	LTE	VoLTE	Cat4
RC7611-1			Cat1
RC7611D	LTE	NA (Data only)	Cat4
RC7611D-1			Cat1
RC7612 ^a	LTE	NA (Data only)	Cat4
RC7612-1 ^a	UMTS (DC-HSPA+, HSPA+, HSPA, WCDMA)		Cat1
RC7620	LTE	Circuit switch voice + VoLTE	Cat4
RC7620-1	UMTS (DC-HSPA+, HSPA+, HSPA, WCDMA) GSM/GPRS/EDGE		Cat1
RC7630	LTE	VoLTE	Cat4
RC7630-1			Cat1
RC7630J ^a			Cat4

a. Limited Availability

To simplify cellular connectivity, the Semtech RC76xx has been designed to support Ready-To-Connect. To learn more about Ready-To-Connect capabilities and to know which variant already supports this feature, please get in touch with your Semtech sales representative.

GNSS functionality is available as a SKU-dependent feature.

In addition to modem features, the Semtech RC76xx embeds several cores for maximum flexibility and security for embedded software execution, including:

- A Telecom Core that natively manages 4G modem features

The following tables detail supported RF bands/connectivity.

Table 1-2: RC7611, RC7611-1, RC7611D, RC7611D-1 Supported Bands / Connectivity

Technology	RF Band	Transmit Band (Tx) (MHz)	Receive Band (Rx) (MHz)	Notes
LTE	B2	1850–1910	1930–1990	MIMO ^a and diversity
	B4	1710–1755	2110–2155	
	B5	824–849	869–894	
	B12	699–716	729–746	
	B13	777–787	746–756	
	B14	788–798	758–768	
	B25	1850–1915	1930–1995	
	B26	814–849	859–894	
	B66	1710–1780	2110–2200	
	B71	663–698	617–652	
GNSS ^b	GPS		1575.42 ± 1.023	
	GLONASS		1597–1606	
	Galileo		1575.42 ± 2.046	
	BeiDou		1561.098 ± 2.046	

a. Downlink MIMO 2x2

b. GNSS support is SKU-dependent.

Table 1-3: RC7620 and RC7620-1 Supported Bands/Connectivity

Technology	RF Band	Transmit Band (Tx) (MHz)	Receive Band (Rx) (MHz)	Notes
LTE	B1	1920–1980	2110–2170	MIMO ^a and diversity
	B3	1710–1785	1805–1880	
	B7	2500–2570	2620–2690	
	B8	880–915	925–960	
	B20	832–862	791–821	
	B28	703–748	758–803	
UMTS	B1	1920 – 1980	2110–2170	Diversity
	B8	880–915	925–960	
GSM/GPRS/EDGE	E-GSM 900	880–915	925–960	
	DCS 1800	1710–1785	1805–1880	

Table 1-3: RC7620 and RC7620-1 Supported Bands/Connectivity (Continued)

Technology	RF Band	Transmit Band (Tx) (MHz)	Receive Band (Rx) (MHz)	Notes
GNSS ^b	GPS		1575.42 ± 1.023	
	GLONASS		1597–1606	
	Galileo		1575.42 ± 2.046	
	BeiDou		1561.098 ± 2.046	

a. Downlink MIMO 2x2

b. GNSS support is SKU-dependent.

Table 1-4: RC7630 and RC7630-1 Supported Bands/Connectivity

Technology	RF Band	Transmit Band (Tx) (MHz)	Receive Band (Rx) (MHz)	Notes
LTE	B1	1920–1980	2110–2170	MIMO ^a and diversity
	B3	1710–1785	1805–1880	
	B5	824–849	869–894	
	B7	2500–2570	2620–2690	
	B8	880–915	925–960	
	B18	815–830	860–875	
	B19	830–845	875–890	
	B21	1447.9–1462.9	1495.9–1510.9	
GNSS ^b	GPS		1575.42 ± 1.023	
	GLONASS		1597–1606	
	Galileo		1575.42 ± 2.046	
	BeiDou		1561.098 ± 2.046	
	QZSS		1575.42 ± 1.023	

a. Downlink MIMO 2x2

b. GNSS support is SKU-dependent.

Table 1-5: RC7630J^a Supported Bands/Connectivity

Technology	RF Band	Transmit Band (Tx) (MHz)	Receive Band (Rx) (MHz)	Notes
LTE	B1	1920–1980	2110–2170	MIMO ^b and diversity
	B3	1710–1785	1805–1880	
	B5	824–849	869–894	
	B18	815–830	860–875	
	B19	830–845	875–890	
GNSS ^c	GPS		1575.42 ± 1.023	
	GLONASS		1597–1606	
	Galileo		1575.42 ± 2.046	
	BeiDou		1561.098 ± 2.046	
	QZSS		1575.42 ± 1.023	

- a. Limited availability.
- b. Downlink MIMO 2x2
- c. GNSS support is SKU-dependent.

Table 1-6: RC7612 and RC7612-1 Supported Bands / Connectivity (Limited Availability)

Technology	RF Band	Transmit Band (Tx) (MHz)	Receive Band (Rx) (MHz)	Notes
LTE	B2	1850–1910	1930–1990	MIMO ^a and diversity
	B4	1710–1755	2110–2155	
	B5	824–849	869–894	
	B12	699–716	729–746	
	B13	777–787	746–756	
UMTS	B2	1850–1910	1930–1990	
	B4	1710–1755	2110–2155	
	B5	824–849	869–894	
GNSS ^b	GPS		1575.42 ± 1.023	
	GLONASS		1597–1606	
	Galileo		1575.42 ± 2.046	
	BeiDou		1561.098 ± 2.046	

- a. Downlink MIMO 2x2
- b. GNSS support is SKU-dependent.

1.2 Interfaces

The Semtech RC76xx provides the following interfaces and peripheral connectivity:

- UIM interface—See [UIM Interface](#)
 - eSIM—See [eSIM / UIM2 Interface](#)
- VBAT_RF/VBAT_BB power supply— See [Power Supply Ratings](#)
- RF—See [RF](#)
- GNSS (RF_GNSS)—See [GNSS](#)
- ON/OFF control:
 - POWER_ON_N—See [POWER_ON_N](#)
 - Reset signals—See [Reset Signals \(RESET_IN_N and RESET_OUT_N\)](#)
- USB 2.0—See [USB](#)
- UART serial links—See [UART](#)
- GPIOs—See [General Purpose Input / Output](#)
- I²C—See [I2C Interface](#)
- 1.8V voltage reference— See [VGPIO](#)
- ADCs—See [ADC](#)
- Digital audio (PCM/I²S)— See [Digital Audio](#)
- SPI bus— See [SPI Bus](#)
- Antenna control—See [Antenna Control](#)
- System clock outputs—See [Clock](#)
- Test pins—See [Test Pins](#)
- Tx Activity Indicator (TX_ON)—See [Tx Activity Indicator \(TX_ON\)](#)

1.3 Common Flexible Form Factor (CF3)

The Semtech RC76xx belongs to the Common Flexible Form Factor (CF3) family of WWAN modules. These modules share the same mechanical dimensions (same width and length with varying thicknesses) and footprint. The CF3 form factor provides a unique solution to a series of problems faced commonly in the WWAN module space as it:

- Accommodates multiple radio technologies and band groupings
- Supports bit-pipe (Essential Module Series) and value-add (Smart Module Series) solutions
- Offers electrical and functional compatibility

1.4 Physical Dimensions and Connection Interface

The Semtech RC76xx module is a compact, robust, fully shielded and labeled (laser-etched) module with the dimensions noted in [Table 1-7](#).

Table 1-7: Module Dimensions^a

Parameter	Nominal	Tolerance	Units
Length	23.00	±0.10	mm
Width	22.00	±0.10	mm
Thickness	2.50	±0.20	mm
Weight	2.6	±1.0	g

a. Dimensions are accurate as of the release date of this document.

The Semtech RC76xx module is an LGA form factor device. All electrical and mechanical connections are made through the 238 Land Grid Array (LGA) pads on the bottom side of the PCB. (See [Figure 10-1](#) for details.)

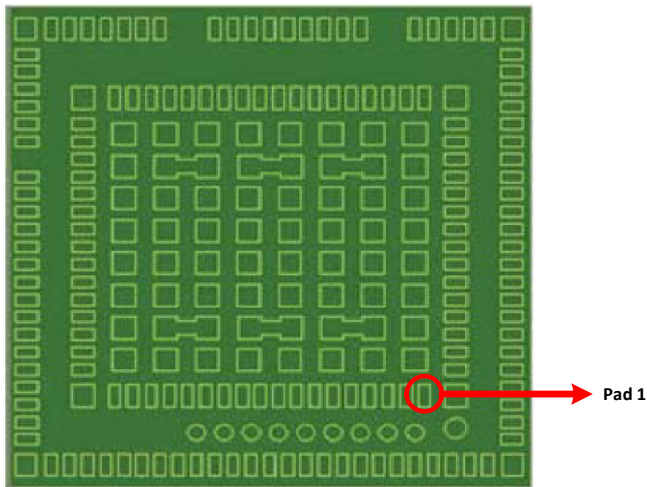

Figure 1-1: RC76 Series Module Bottom View

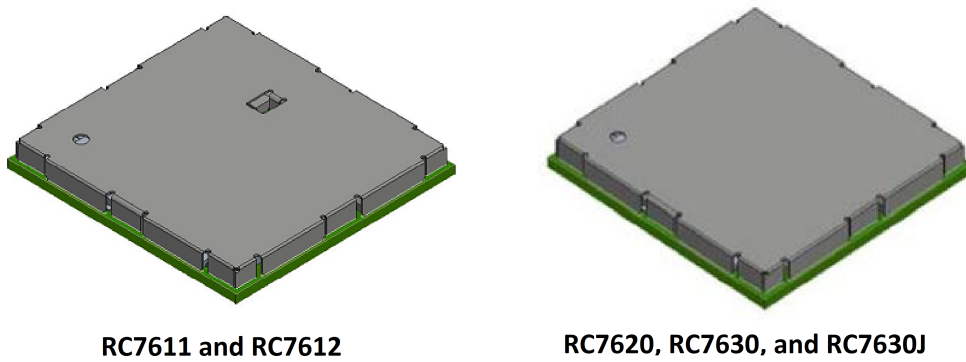

Figure 1-2: RC76 Series Shield View

The 239 pads have the following distribution:

Table 1-8: LGA Pad Types

Pad Type / Quantity		Dimensions	Pitch
Signal Pads	66 inner pads	1.0x0.5 mm	0.8 mm
	91 outer pads		
Test Points	9 test points	0.8 mm (diameter)	1.20 mm
Ground Pads	64 inner pads	1.0x1.0 mm	1.83 mm/ 1.48 mm
	4 inner corner pads	1.0x1.0 mm	-
	4 outer corner pads	1.0x0.9 mm	-
Polarity Mark	1 polarity mark (Ground)	1.0 mm (diameter)	-

2: Functional Specifications

2.1 Architecture

The following figure presents an overview of the Semtech RC76xx module's internal architecture and external interfaces.

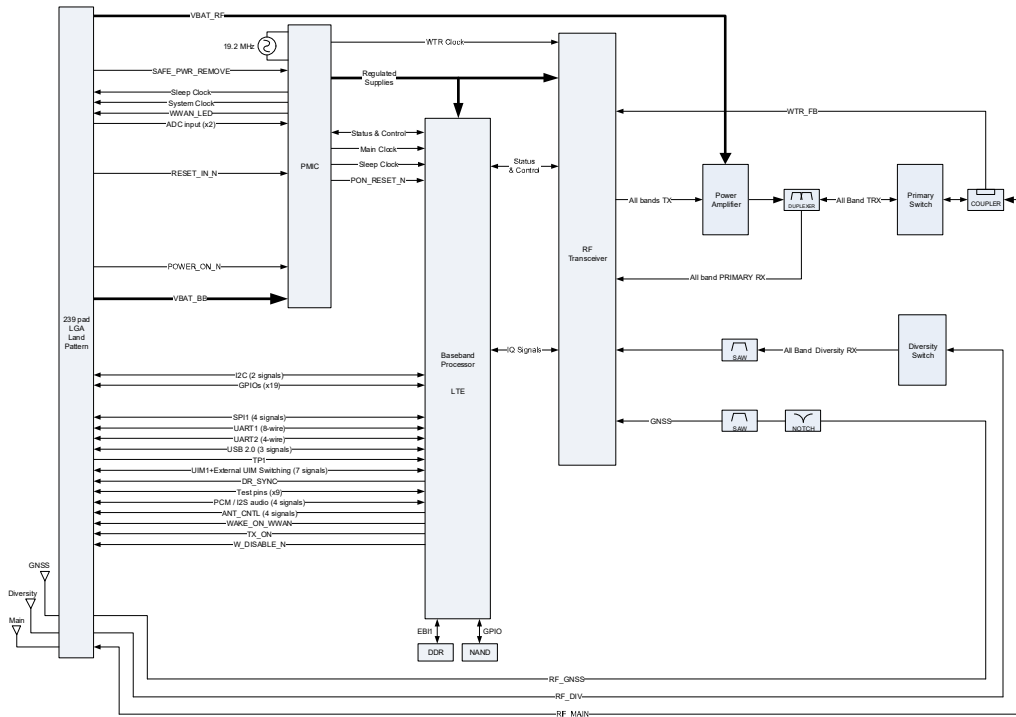

Figure 2-1: RC7611, RC7611-1, RC7611D, RC7611D-1, RC7612*, RC7612-1*, RC7630, RC7630-1, RC7630J* Architecture Overview

* Limited availability

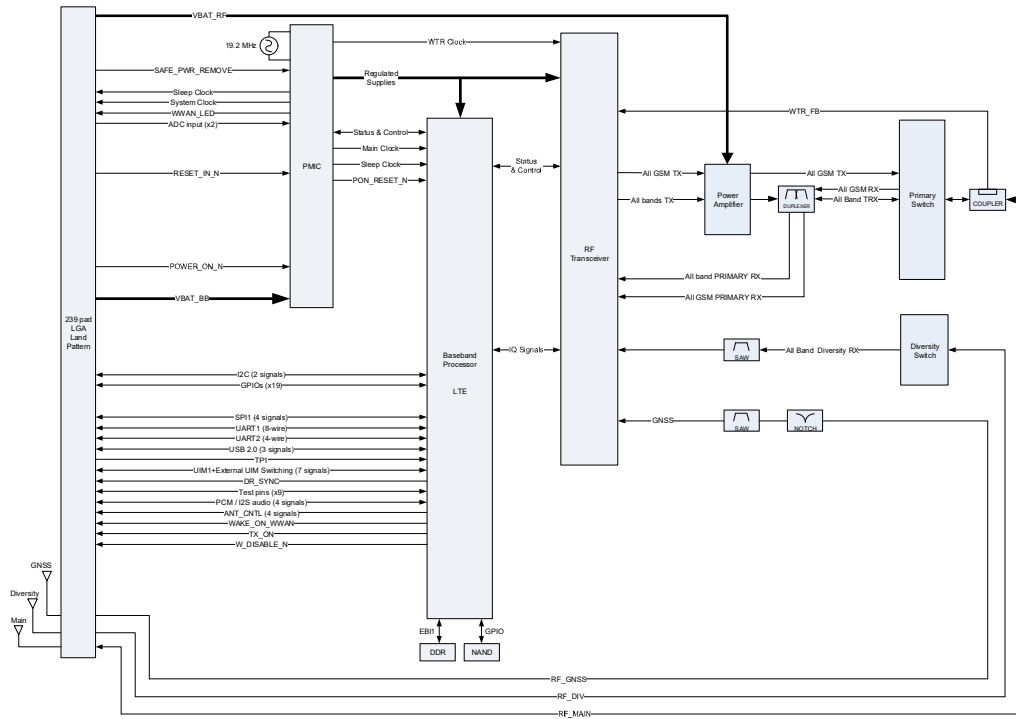

Figure 2-2: RC7620, RC7620-1 Architecture Overview

2.2 Telecom Features

Table 2-1 summarizes the Semtech RC76xx module’s capabilities offered through the Telecom core.

Table 2-1: Module Capabilities

Feature	Description
Electrical	3.2–4.3V supply voltage (VBAT_BB, VBAT_RF): <ul style="list-style-type: none"> Single supply, VBAT_BB tied to VBAT_RF or Dual supplies, single supply each for VBAT_BB and VBAT_RF
Voice (Digital Audio)	<ul style="list-style-type: none"> PCM/I²S digital audio interface Supports Enhanced Full Rate (EFR), Full Rate (FR), Half Rate (HR), and both Narrow-Band and Wide-band Adaptive Multirate (AMR-NB and AMR-WB) vocoders MO and MT calling Echo cancellation and noise reduction Emergency calls (112, 110, 911, etc.) Incoming call notification DTMF generation Internal codec driver for WM8944

Table 2-1: Module Capabilities (Continued)

Feature	Description
SMS	<ul style="list-style-type: none"> ▪ SMS MO and MT ▪ CS and PS support ▪ SMS saving to UIM card or ME storage ▪ SMS reading from UIM card or ME storage ▪ SMS sorting ▪ SMS concatenation ▪ SMS Status Report ▪ SMS replacement support ▪ SMS storing rules (support of AT+CNMI, AT+CNMA)
Supplementary services	<ul style="list-style-type: none"> ▪ Call Barring ▪ Call Forwarding ▪ Call Hold ▪ Caller ID ▪ Call Waiting ▪ Multi-party service ▪ USSD ▪ Automatic answer

2.2.1 Network Technology Specifications

2.2.1.1 LTE Specifications

The following table describes LTE specifications for Semtech RC76xx modules.

Table 2-2: Supported LTE Specifications

Standard	Feature Description
R13	<ul style="list-style-type: none"> ▪ eDRX (Extended Discontinuous Reception) to extend battery life in devices that do not require frequent network access ▪ PSM (Power Saving Mode) to reduce power consumption

Table 2-2: Supported LTE Specifications (Continued)

Standard	Feature Description
R10	<ul style="list-style-type: none"> ▪ Release 10 mandatory LTE features ▪ RC76xx Data rates: <ul style="list-style-type: none"> • Cat 1 FDD (up to 10 Mbps downlink, 5 Mbps uplink) • Cat 4 FDD (up to 150 Mbps downlink, 50 Mbps uplink) ▪ 1.4 MHz, 3 MHz, 5 MHz, 10 MHz, 15 MHz and 20 MHz RF bandwidth ▪ IPv6, QoS ▪ NAS & RRC standalone security ▪ Commercial Mobile Alert System (CMAS) ▪ ETWS (Earthquake Tsunami Warning System) notification ▪ Inter-frequency/bandwidth mobility ▪ DRX cycle while in: <ul style="list-style-type: none"> • Connected mode • Idle mode ▪ UE IRAT support for Self Organizing Networks and Automatic Neighbor Relation (SON AR)
System Determination	<ul style="list-style-type: none"> ▪ Frequency Scan and System Selection within LTE ▪ LTE BPLMN support ▪ LTE Connected mode OOS ▪ System selection across RATs, Standalone Security, Dedicated EPS Bearer Management and Dormancy ▪ 256 UPLMN and 256 OPLMN entries in UIM support ▪ Carrier Specific BSR Requirements
Data	<ul style="list-style-type: none"> ▪ Data call throttling ▪ Default IPv4 bearer activation at attach/IPv4 data call ▪ NW and UE initiated QoS ▪ Dual IP and IPv4/IPv6 continuity ▪ IPv4/IPv6 session continuity ▪ W/G IP session continuity ▪ Emergency services—LTE NAS Support for Control Plane LTE Positioning Protocol

2.2.1.2 GSM / GPRS / EDGE Specifications

The following table describes GSM/GPRS/EDGE specifications for Semtech RC7620 modules.

Table 2-3: Supported GSM Specifications

Standard	Feature Description
GPRS	Packet-switched data: <ul style="list-style-type: none"> ▪ DTM (simple class A) operation ▪ GPRS Multislot class 10 (with backoff^a)—Four Rx slots (maximum), two Tx slots (maximum), five active slots total ▪ Coding schemes—CS1–CS4 ▪ GEA1, GEA2, and GEA3 ciphering ▪ WCDMA/GERAN system selection

Table 2-3: Supported GSM Specifications (Continued)

Standard	Feature Description
EDGE	<ul style="list-style-type: none"> ▪ E2 power class for 8 PSK ▪ DTM (simple class A), multislot class 12 ▪ EGPRS—Multislot class 12 (with backoff^a)—Four Rx slots (maximum), four Tx slots (maximum), five active slots total ▪ Coding schemes—MCS1–MCS9 ▪ BEP reporting ▪ SRB loopback and test modes A and B ▪ 8-bit and 11-bit RACH ▪ PBCCH support ▪ One-phase/two-phase access procedures ▪ Link adaptation and IR ▪ NACC, extended UL TBF ▪ PFC/PFI (Packet Flow Context/Packet Flow Identifier) support - allows identity tagging of RLC blocks to identify separate QoS streams at the radio link layer ▪ GPRS/EDGE MSC12-EDA - permits allocation of more than two uplink timeslots for GPRS/EDGE ▪ Enh DL RLC/MAC Segmentation - permits reception of MAC control messages that exceed one radio block capacity in length ▪ Enhanced Ext UL TBF - dummy block transmission is punctured for current saving purposes ▪ 2G PS handover - packet-switched equivalent of CS handover to ensure faster cell change and improved throughput ▪ WCDMA/GERAN ▪ Band Scan: Run-time Configurable RRC Band Scan Order ▪ Power and Network Optimizations: Frame Early Termination for Power Optimization ▪ Protocols: MRAB-Pack-1 Enhancements - reduces multi-RAB call drops ▪ GPRS/EDGE - Class 33 (296 kbps downlink, 236.8 kbps uplink) ▪ CSD (Circuit-switched data bearers) ▪ Release 4 GERAN Feature Package 1 ▪ SAIC / DARP Phase 1
EDGE	<ul style="list-style-type: none"> ▪ Latency reduction ▪ Repeated FACCH, Repeated SACCH ▪ A-GPS support ▪ GPRS ROHC ▪ Enhanced Operator Name String (EONS) ▪ Enhanced Network Selection (ENS)

a. Backoff is firmware dependent. 2G power backoff level is 3dB at the maximum power level as per 3GPP standards.

2.2.1.3 WCDMA Specifications

The following table describes WCDMA specifications for Semtech RC7620, RC7612*, RC7612-1* modules.

Table 2-4: Supported WCDMA Specification

Standard	Feature Description
R99	<ul style="list-style-type: none"> ▪ All modes and data rates for WCDMA FDD, with the following restrictions: <ul style="list-style-type: none"> • The downlink supports the following specifications: <ul style="list-style-type: none"> • Up to four physical channels, including the broadcast channel (BCH), if present • Up to three dedicated physical channels (DPCHs) • Spreading factor (SF) range support from 4 to 256 • The uplink supports the following specifications: <ul style="list-style-type: none"> • One physical channel, eight TrCH, and 16 TrBks starting at any frame boundary • A maximum data rate of 384 kbps • Full SF range support from 4 to 256 ▪ PS data rates of 384 kbps DL and 384 kbps UL
R8 HSDPA	<ul style="list-style-type: none"> ▪ PS data speeds up to 42 Mbps (UE category 24) on the downlink ▪ HS-DSCH (HS-SCCH, HS-PDSCH, and HS-DPCCH) ▪ Maximum of 15 HS-PDSCH channels, both QPSK and 16 QAM modulation ▪ Support for 3GPP-defined features: <ul style="list-style-type: none"> • R99 transport channels • Maximum of four simultaneous HS-SCCH channels • CQI and ACK/NACK on HS-DPCCH channel • All incremental redundancy versions for HARQ • Configurable support for power classes 3 or 4, per TS 25.101 • TFC selection limitation on UL factoring in transmissions on the HS-DPCCH, per TS 25.133 ▪ Switching between HS-PDSCH and DPCH channel resources, as directed by the network ▪ Network activation of compressed mode by SF/2 or HLS on the DPCH for conducting inter-frequency or inter-radio access technology (RAT) measurements when the HS-DSCH is active
R8 HSDPA	<ul style="list-style-type: none"> ▪ STTD on both associated DPCH and HS-DSCH simultaneously ▪ CLTD mode 1 on the DPCH when the HS-PDSCH is active ▪ STTD on HS-SCCH when STTD or CLTD mode 1 are configured on the associated DPCH ▪ SCH-IC support ▪ HS-DSCH DRX support

Table 2-4: Supported WCDMA Specification (Continued)

Standard	Feature Description
R6 HSUPA	<ul style="list-style-type: none"> ▪ E-DCH data rates of up to 5.76 Mbps for 2 ms TTI (UE category 6) uplink ▪ Support for 3GPP-defined features: <ul style="list-style-type: none"> • E-AGCH, E-RGCH, and E-HICH channels for downlink; E-RGCH and E-HICH supports serving and non-serving radio links, with up to four radio links in the E-DCH active set • All HARQ incremental redundancy versions and maximum number of HARQ retransmissions • Uplink E-DCH channel with support for up to four E-DPDCH channels • HSUPA channels run simultaneously with R99 and HSDPA channels ▪ STTD on all HSUPA downlink channels ▪ CLTD mode 1 on HS-PDSCH and DPCH along with HSUPA channels ▪ Switch between HSUPA channels and DPCH channel resources, as directed by the network ▪ Handover using compressed mode with simultaneous E-DCH and HS-DSCH interactive, background, and streaming QoS classes ▪ CSD fallback ▪ DPCCH DTX support

*Limited Availability

2.2.2 Modem Specifications

Table 2-5: Supported Modem Specifications

Standard	Feature Description
Data	<ul style="list-style-type: none"> ▪ IPHC protocol as RFC 2509 ▪ Stateless DHCPv4 protocol to get P-CSCF and DNS addresses ▪ IPv4/IPv6 ▪ Dual IP on single QMAP PDN ▪ Multi-QMAP PDN Data Call

2.3 Multi-Core Processing Capabilities

The Semtech RC76xx is a powerful multiple-core system that includes:

- One QDSP6 core, embedding Telecom firmware with integrated cellular voice, VoLTE, data and wireless Internet connectivity
- One Cortex A7 core entirely dedicated to Semtech Proprietary application and natively provided with ThreadX operating system

3: Technical Specifications

3.1 Environmental

The environmental specifications for operation and storage of the Semtech RC76xx are defined in [Table 3-1](#).

Table 3-1: Environmental Specifications

Parameter	Range	Operating Class
Ambient Operating Temperature	-30°C to +70°C	Class A (Operational, 3GPP compliant)
	-40°C to +85°C	Class B (Operational, non-3GPP compliant)
Ambient Storage Temperature	-40°C to +85°C	-
Ambient Humidity	85% or less	-

Class A is defined as the operating temperature range within which the device:

- Shall exhibit normal function during and after environmental exposure.
- Shall meet the minimum requirements of 3GPP or appropriate wireless standards.

Class B is defined as the operating temperature range within which the device:

- Shall remain fully functional during and after environmental exposure
- Shall exhibit the ability to establish any of the device's supported call modes (SMS, Data, and emergency calls) at all times even when one or more environmental constraint exceeds the specified tolerance.
- Unless otherwise stated, full performance should return to normal after the excessive constraint(s) have been removed.

3.2 Power Supply Ratings

The Semtech RC76xx operates using DC power supplied via the VBAT_RF and VBAT_BB signals. Power supply options are:

- A single regulated DC power supply (3.7V nominal)
- Two regulated DC power supplies (3.7V nominal), one each for VBAT_BB and VBAT_RF

Table 3-2: Power Supply Pins

Pin	Name	Direction	Function	Notes
63, 158	VBAT_BB	Input	Baseband power supply	63 — Must be used 158 — Optional
61, 62, 157	VBAT_RF	Input	RF power supply	61/62 — Must be used 157 — Optional

Table 3-3: Operating Conditions

Parameter	Min	Typ	Max	Units	Notes
Power supply voltage ^{a, b}	3.2	3.7	4.3	V	Must be within min/max values over all operating conditions (including voltage ripple, drop, and transient).
Power supply ripple	-	-	100	mV _{pp}	See Figure 3-1 .
Extended power supply voltage ^c	3.0	3.7	4.3	V	To enable this operating condition, use AT!PCVOLTLIMITS for voltage monitoring. Refer to the RC76xx AT Command Reference Guide for more details.
Power supply voltage drop	-	-	250	mV _{pp}	See Figure 3-1 and Figure 3-2 .
Power supply voltage transient (overshoot/undershoot)	-	-	300	mV _{pp}	See Figure 3-1 .
Output current rating ^d	LTE, UMTS	1.0	1.5	-	<ul style="list-style-type: none"> Typical value varies and depends on output power, band, and operating voltage. See Current Consumption for values measured under normal operating conditions. Max value measured over 100 μs period.
	GSM	2.2	3.0	-	

- a. Power supply voltage outside the required range may affect call quality (dropped calls, data transfer errors, etc.)
- b. For Absolute Maximum Ratings, see [Table 3-34](#).
- c. VBAT from 3.0-3.2V is functional (3GPP performance is not guaranteed) but the power source must be sufficient, and the impedance of power source/power path should be as low as possible to reduce the voltage drop.
- d. These values include a margin. For information on current consumption, see [Current Consumption](#).

Customer should characterize the ripple, drop, and transient response (overshoot/undershoot) of the power supply delivery system at the module input under full transmit power in Semtech RC76xx modules. To minimize voltage variation, add suitable capacitors to the supply line as close as possible to the module — depending on the power supply design, these capacitors may range from tens to several thousand μF.

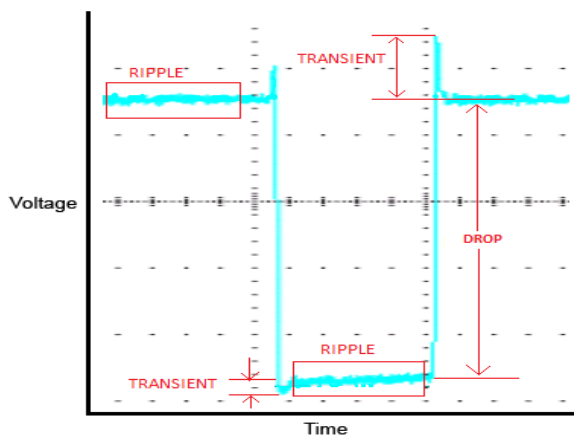

Figure 3-1: Power Supply Characteristics

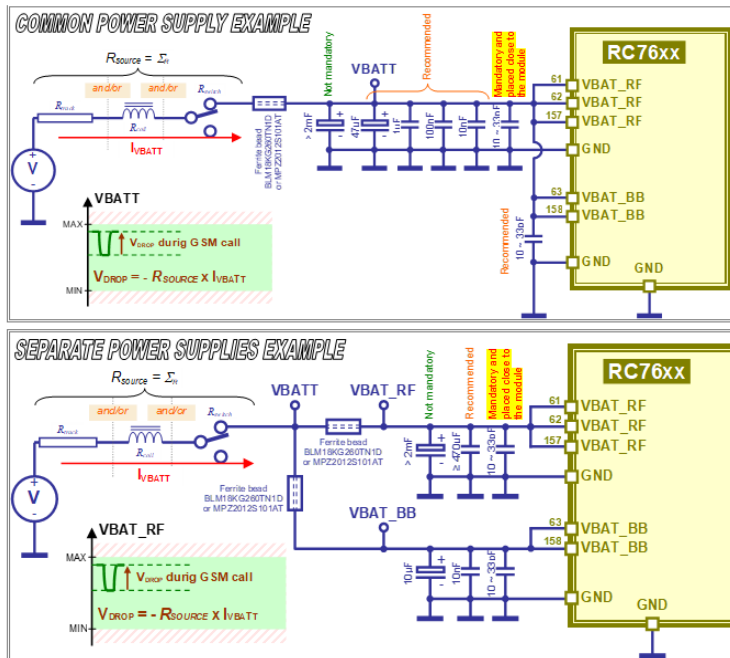

Figure 3-2: Common and Separate Power Supply Examples

3.2.1 Under-Voltage Lockout (UVLO)

The power management section of the Semtech RC76xx includes an under-voltage lockout circuit that monitors supply and shuts down when VBAT_BB falls below the threshold.

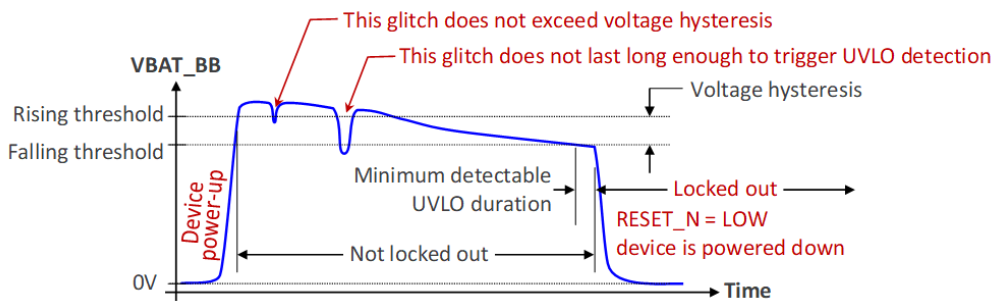

Figure 3-3: Under-Voltage Lockout (UVLO) Diagram

Note: Due to under-voltage lockout, which causes the PMIC to shutdown directly, the device is powered down.

The Semtech RC76xx will power down by PMIC directly and remain off until VBAT_BB returns to the valid range and the ON/OFF signal is active.

Note: If the device experiences six consecutive UVLO events less than 45 seconds apart (approximately) and a host-initiated power down or reset has not occurred, the device enters a mode in which only the DM port enumerates on the USB.

Table 3-4: UVLO Specifications

Parameter	Min	Typ	Max	Units
Threshold voltage, falling	2.225	2.4	2.80	V
Threshold voltage, accuracy	-5	-	+5	%
Hysteresis	-	425	-	mV
UVLO detection interval	-	1.0	-	μs

3.2.2 Sudden Power Loss

Any sudden power loss of the embedded module during operating mode will increase the EFS crash risk, even in the power on or power down sequence. It is strongly recommended to remove the power only after the module is in power down mode.

3.2.3 Power Consumption States

The Semtech RC76xx has four basic power states: Active, Sleep, Power Saving Mode (PSM), and Off. As the module transitions between power states, the range of available device functionality adjusts appropriately, as described in [Table 3-5](#) and [Figure 3-4](#).

In the Active state, the module is ON with the application processor running. In Sleep state, the processor suspends its activity, reducing power consumption. The Active state has more than one power mode to reduce power consumption. Power Saving Mode (PSM; network-dependent) may be enabled to achieve the lowest possible average power consumption.

Table 3-5: Supported Power States

State	Description
Active	<p>Module is fully powered (ThreadX runs in the Application Core; modem is on) and operating in one of the following modes:</p> <ul style="list-style-type: none"> Full function (WWAN radio active; GNSS radio can be turned on/off) — Highest power consumption. Idle mode (WWAN radio on; Module registered on network, but no active connection; GNSS radio can be turned on/off) Airplane mode (WWAN radio off; GNSS radio can be active if allowed by PRI) eDRX (Extended Discontinuous Reception)—eDRX mode provides a ‘flexible sleep’ for the modem, which significantly reduces energy consumption. For eDRX details, see Extended Discontinuous Reception (eDRX).
Sleep	<ul style="list-style-type: none"> Lower power consumption than Active state, but higher than PSM. Application Core is sleeping; modem is in DRX/eDRX. The processor monitors signals (triggers) that can ‘wake’ the module—see Wakeup Interrupt (Sleep State) for details. <p>Sleep state can be entered based on USB-SS (if USB is connected to the module), UART_DTR, wake_lock(), configured GPIOs, and QMI exchanges from the modem.</p>

Table 3-5: Supported Power States (Continued)

State	Description
PSM (Power Saving Mode)	<p>3GPP Release 12 introduced network support of PSM. PSM allows the module to negotiate, with the network, an extended period during which registration context with the network is retained while the module is unreachable. During the negotiated period, the module enters a very low-power dormant state.</p> <p>After the specified period, the modem and application processors boot up and the module sends a TAU (Tracking Area Update) to the network.</p> <p>After sending the TAU, the module remains active to allow any pending data to be exchanged with the network. Then, after a negotiated period of inactivity, the module automatically returns to PSM to repeat the cycle.</p> <p>For PSM details, see Power Saving Mode (PSM).</p> <p>When the 3GPP PSM feature is accepted by the network, (see Power Saving Mode (PSM)), the RC76 module will directly enter into the PSM power state. The module cannot remain in another power state other than PSM when the PSM 3GPP feature is accepted by the network.</p>
OFF (VBATT_ON)	<p>Module is OFF (VBATT is ON):</p> <ul style="list-style-type: none"> Active state (POWER_ON_N is asserted) - This is a low level signal to turn on the module. POWER_ON_N is de-asserted - The module is not turned on but consumes 6uA.

Table 3-6: PSM Wakeup Sources

Type	Description
TAU timer	<p>Periodic TAU—PSM Cycle Timer (T3412)</p> <p>Configurable timer specifying PSM sleep duration. Applies to PSM only.</p>
Wakeup timer	<p>Derived from TAU timer (value is automatically set slightly shorter than TAU timer to ensure module boot completes before TAU timer expires)</p>
RESET_IN_N	<p>Resets the module with POWER_ON_N ON.</p> <p><i>Note: If RESET_IN_N is used when POWER_ON_N is OFF, an emergency power off occurs—see Emergency Power Off</i></p>
POWER_ON_N	<p>Wakes the module when asserted (transitions from OFF to ON).</p>

Figure 3-4 illustrates the current consumption requirements of the different power states and the possible transitions between power states. For specific values, see [Current Consumption](#)

Note: Illustration not to scale. Values are based on the RC7611 and RC7611D. Refer to [Current Consumption](#) for specific consumption values per variant.

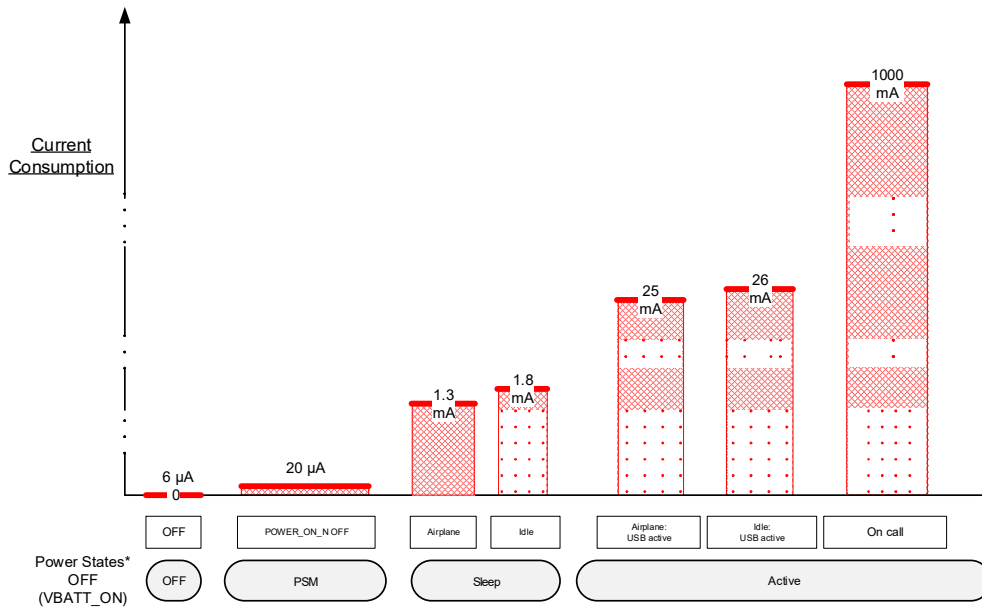

Figure 3-4: Overview of Current Consumption and Power States

Note: *Refer to Table 3-5

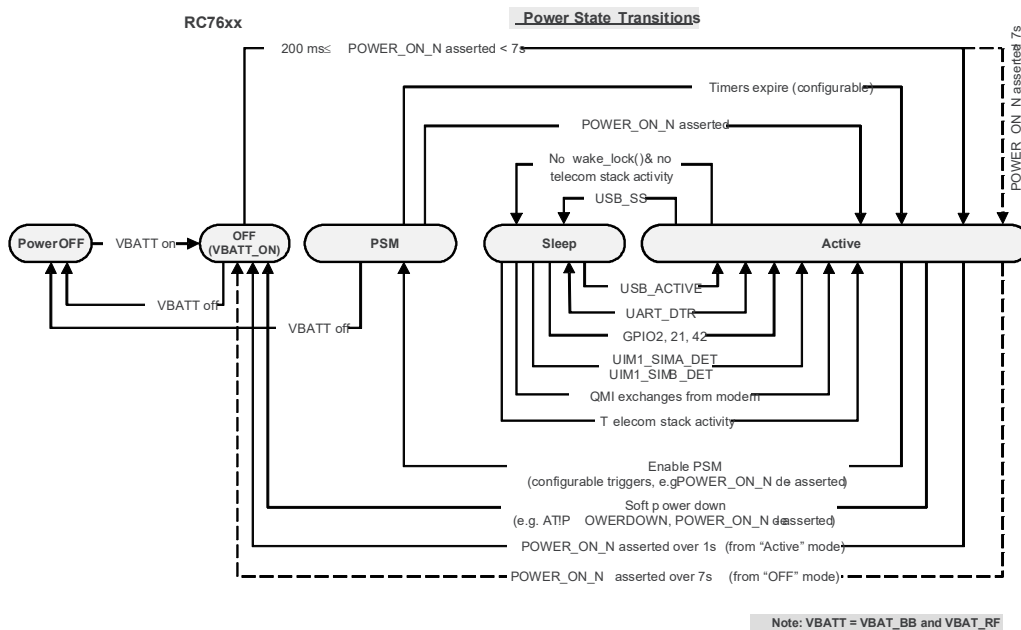

Figure 3-5: Power State Transitions

3.2.4 Power Saving Mode (PSM)

Power Saving Mode (PSM) is a 3GPP feature that allows the RC76xx to minimize power consumption by registering on a PSM-supporting LTE network, entering a very low power 'dormant' state for a pre-configured duration (via a periodic TAU (Tracking Area Update) timer), and then booting up for a short period to transmit/receive data, before re-entering PSM. During the dormant period, the module remains unreachable by the network until woken by a configured wakeup source (POWER_ON_N, RESET_IN_N) or the expiry of the periodic TAU timer.

Note: When using PSM, the POWER_ON_N signal must be floating. If this signal is grounded, it will automatically trigger a wake. When the PSM mode is activated, the VGPI0 voltage is switched off and I/O pins states are undefined. Once the module is woken up, the VGPI0 is switched on again and the I/O pin states return to the states they had before entering PSM. To avoid extra power-consumption, the host should place the signals connected to the module in high impedance or floating.

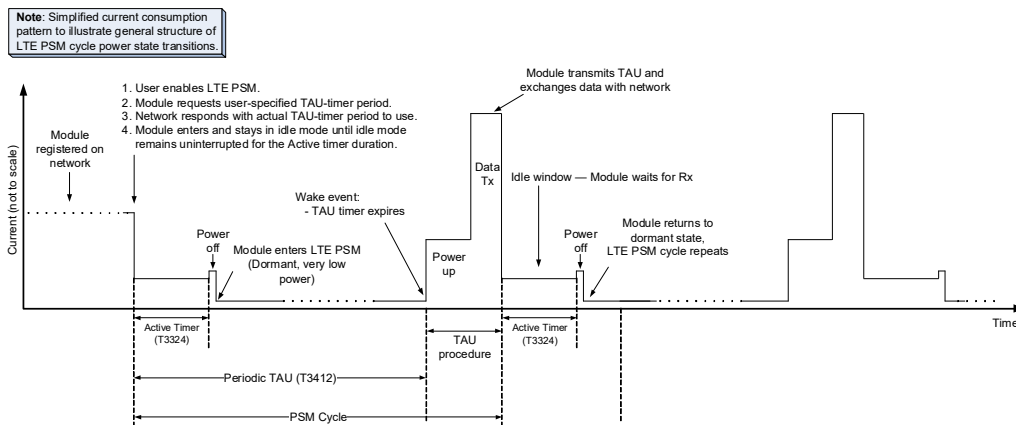

Figure 3-6: PSM Example (Simplified)

Typical candidates for PSM are systems (such as monitors and sensors) that:

- Require long battery life (low power consumption)
- Tolerate very long latency for mobile-terminated SMS/data
- Do not use mobile-terminated voice
- Send and/or receive data infrequently and periodically (e.g. on a given schedule of once every few hours, days, weeks, etc.)

For example, a module connected to a sensor can be configured to:

- Wake periodically to transmit collected data to a server or network entity.
- Wait a short (configured) period of time to receive transmissions (e.g 60 seconds) and then return to its dormant state.

Table 3-6 on page 30 describes the available triggers for waking an RC76xx from PSM. These triggers are configured using the methods described in Table 3-7.

Table 3-7: PSM-Related Application User Commands/Interfaces

Type	Command/Interface ^a	Description
AT	+CPSMS	<p>3GPP-defined command (3GPP TS27.007 Release 12) that allows direct control of all LTE PSM parameters, and is useful for advanced users wanting to test/experiment with different options. This command is limited to networks that support PSM.</p> <p>It is not expected that every user must be fully versed in the details of PSM to take advantage of its capabilities.</p> <p>Use this command to:</p> <ul style="list-style-type: none"> ▪ Enable/disable LTE PSM. ▪ Configure Period TAU timer (T3412) with a requested maximum duration of the dormant period. ▪ Configure Active timer (T3324) with a requested 'idle mode time' (the duration the module remains idle before going dormant) ▪ This command follows the 3GPP TS 27.007, Release 12 specification, with exceptions noted for certain parameters. <p><i>Note: The requested timer values are negotiated with the network and the final negotiated values take effect immediately, then persist across power cycles (e.g. after a power cycle, the settings will be used during network attach).</i></p>
	! POWERMODE	Custom Semtech command that allows application developers to enable PSM without the complexity of the AT+CPSMS syntax
	! POWERWAKE	Custom Semtech command used to configure PSM timers (TAU time, active time) in seconds. Note that only timer values supported by the 3GPP standard are allowed.
<p><i>Note: AT!POWERWAKE (configuration of PSM timers) should be used with AT!POWERMODE (activation of the PSM feature). Using these proprietary SWI commands is equivalent to using the 3GPP AT+CPSMS command. AT+CPSMS will automatically change settings in AT!POWERMODE / AT!POWERWAKE and vice versa. As soon as the network accepts the PSM feature based on these command settings, the PSM power state will be activated in the RC76 module (see Table 3-5 for details).</i></p>		

a. For AT command details, refer to RC76xx AT Command Reference, available at <http://source.sierrawireless.com>.

PSM Process Example

The following example describes how the module uses PSM (as shown in [Figure 3-4](#)):

1. Module registers on an LTE network.
2. User enables PSM via AT command or API library function, specifying the desired TAU timer and Active timer periods, and optional wakeup sources.
3. Module submits the PSM request (including desired TAU timer) to the network.
4. Network responds and indicates whether PSM is supported and (if it is) indicates the actual TAU timer to use.

5. If the network supports PSM:
 - a. Module enters idle mode (waiting for Rx from network).
 - b. When module has remained idle for the Active timer period, module powers off (except for maintaining timer and interrupts) and enters PSM.
 - c. Module remains in PSM for the specified period or until a configured trigger (POWER_ON_N, RESET_IN_N) wakes it.

Note: If traffic must be transmitted when the module is in the sleep portion of the cycle, the module can initiate data/SMS/voice session immediately.

- d. Module powers up before TAU timer expires, then transmits TAU and/or exchanges data with network.
- e. Module enters idle mode and cycle repeats.

Note: When the module is powered up, the PSM request can be re-issued with different timers and triggers to adjust the PSM behavior. These new settings take effect immediately.

Important Notes:

- Carefully select the PSM Periodic-TAU timer and Active Time values to match the intended use case(s) for the module:
 - Periodic TAU PSM Cycle timer (T3412)— Note that while the module is dormant (for the duration of this timer, unless woken by POWER_ON_N or RESET_IN_N), it will be completely unreachable by the network.
 - Active Time (Idle mode time after transmission (T3324))— Make sure to set the Active timer high enough to provide appropriate delay-tolerance for mobile-terminated/ network-originated transmissions to be received.
- When using multiple devices, consider scheduling the modules to wake at different times so that the network does not get flooded by all modules waking and transmitting simultaneously.

Note: RC76xx series modules do not support waking up via ADC or GPIO in PSM state.

3.2.5 Active State to PSM Transition

If the module will be used in situations where it needs to be active very infrequently (for example, in a remote monitoring station that must transmit data periodically—e.g. on a regular schedule ranging from days to weeks or more), PSM may be used to reduce power consumption much more than is possible in Sleep state. Refer to [Figure 3-4](#) for transition conditions. If the module does not enter PSM, the request must be explicitly repeated—the module will not attempt to enter PSM automatically.

3.2.6 Extended Discontinuous Reception (eDRX)

The RC76xx supports eDRX, which is a ‘flexible sleep’ active mode that allows for longer sleep duration (T_{I-eDRX}) and a significant decrease in power consumption compared to regular DRX (T_{I-DRX}).

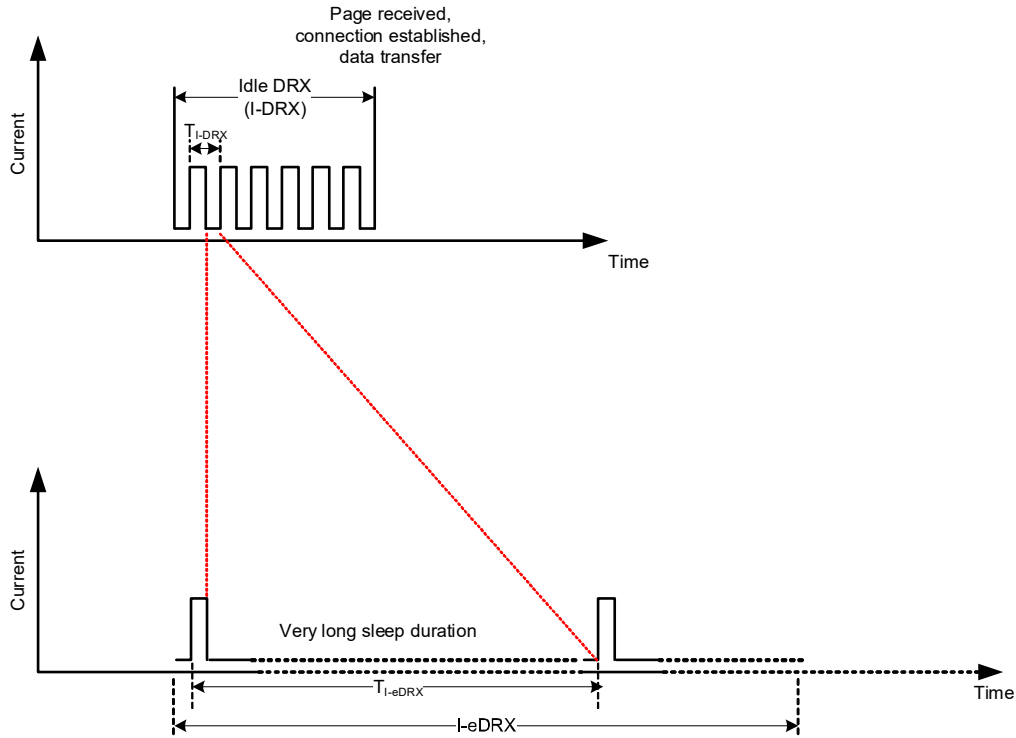

Figure 3-7: eDRX Example (Simplified)

Specifically, the RC76xx supports eDRX, which extend the DRX cycle (the paging cycle comprised of a paging window during which the module is awake and able to receive or transmit on the network, and a sleep period during which the network cannot wake the module) by increasing the sleep duration beyond the DRX maximum of 2.56 seconds:

- I-eDRX (Idle mode eDRX) — The sleep duration of the DRX cycle can be set up to 44 minutes for LTE-M.

Note: If traffic must be transmitted when the module is in the sleep portion of the cycle, the module can initiate data/SMS/voice session immediately.

Table 3-8 describes the available methods for configuring eDRX.

Table 3-8: eDRX-Related Commands^a

Type	Command	Description
AT	+CEDRXS	Enable/disable eDRX, and configure related settings
AT	+CEDRXRDP	Display current eDRX settings

a. For AT command details, refer to RC76xx AT Command Reference, available at <http://source.sierrawireless.com>.

3.2.6.1 eDRX Process Example

- Use the AT+CEDRXS command to configure the desired eDRX behavior.
- During the network attachment process:
 - eDRX request and settings are sent to the network
 - Network responds and indicates whether eDRX is supported for the connection and may adjust the eDRX parameters.
- If eDRX is supported by the network:
 - While in active mode (connected), the sleep duration is used if supported, otherwise the regular DRX sleep duration is used.
 - While in idle mode, the I-eDRX sleep duration is used if supported, otherwise the network uses the standard LTE I-DRX value.

Important Notes:

- The sleep duration must be carefully selected to match the intended use case(s) for the module. While the module is asleep, it will be unreachable by the network. The duration should provide appropriate delay-tolerance for mobile-terminated / network-originated transmissions to be received.
- Due to the extended sleep time compared to regular DRX, eDRX is not suitable for most mobile-terminated voice connections.
- Network-side store and forward is supported — Packets will be stored until the module is reachable.

3.2.7 Current Consumption

The following tables describe the Semtech RC76xx module's current consumption under various power states. Typical values are measured at nominal supply voltage, nominal ambient temperature, and with a conducted 50Ω load on the antenna port.

Note: All current consumption values are tested on the Sierra Development Kit.

Table 3-9: RC7611, RC7611-1, RC7611D, RC7611D-1 Current Consumption Values

Power State	Parameter	Min. ^a	Typ. ^a	Max. ^b	Units	
Active						
LTE Data transfer ^c	B2	210 ^d	700 ^e	980 ^e	mA	
	B4	210 ^d	710 ^e	1000 ^e	mA	
	B5	190 ^d	570 ^e	700 ^e	mA	
	B12	190 ^d	610 ^e	700 ^e	mA	
	B13	190 ^d	680 ^e	800 ^e	mA	
	B14	190 ^d	700 ^e	800 ^e	mA	
	B25	210 ^d	720 ^e	980 ^e	mA	
	B26	190 ^d	580 ^e	700 ^e	mA	
	B66	220 ^d	700 ^e	1000 ^e	mA	
	B71	190 ^d	600 ^e	700 ^e	mA	
Idle — LTE	<ul style="list-style-type: none"> ▪ Registered ▪ Paging cycle=256 	USB active	25	26	39	mA
Airplane mode ^f	Radio off	USB active	25	25	36	mA
Sleep						
Idle — LTE	<ul style="list-style-type: none"> ▪ Registered ▪ Paging cycle=256 	USB-SS	1.7	1.8	6	mA
Idle — LTE eDRX ^g	Period: 40.96 sec	USB-SS	1.5	1.8	4	mA
Airplane mode ^f	Radio off	USB-SS	1	1.3	4	mA
Low Power Mode						
PSM Dormant	Non-active		7	10	20	uA
OFF (VBATT_ON)	Non-active		3	6	10	uA
GNSS ^h						
Acquisition (Airplane mode, cold start)			23	25	35	mA
Tracking (Registered)			23	25	35	mA

- a. Input 3.7V, normal temperature
- b. Input 3.4V, 70°C
- c. Bandwidth 10 MHz, UP/DL RB=50, enable throughput, modulation:QPSK
- d. Tx min.
- e. Tx max.
- f. Radio is turned off and all interfaces setting are default without any external control connection.
- g. eDRX test condition: eDRX setting: at+cdrxs=1,4,"0011", eDRX period = 40.96 sec, PTW = 5.12 sec, DRX cycle = 64 ms, For details on AT commands, see Semtech RC76xx AT Command Reference.

h. GNSS current consumption values are for the GNSS radio only. For total consumption, add the GNSS value to the consumption for the mode being used.

Table 3-10: RC7620, RC7620-1 Current Consumption Values

Power State	Parameter	Min. ^a	Typ. ^a	Max. ^b	Units
Active					
GSM/GPRS/EDGE data transfer	E-GSM 900	160 ^c	600 ^d	2160 ^{d,e} 1020 ^{d,f}	mA
	DCS 1800	150 ^c	560 ^d	1278 ^{d,e} 665 ^f	mA
HSDPA data transfer ^g	B1	180 ^c	803 ^d	1140 ^d	mA
	B8	150 ^c	550 ^d	840 ^d	mA
LTE Data transfer ^h	B1	240 ^c	790 ^d	850 ^d	mA
	B3	240 ^c	740 ^d	900 ^d	mA
	B7	300 ^c	770 ^d	980 ^d	mA
	B8	210 ^c	620 ^d	700 ^d	mA
	B20	210 ^c	750 ^d	850 ^d	mA
	B28	210 ^c	670 ^d	710 ^d	mA
Idle—GSM/GPRS/EDGE	<ul style="list-style-type: none"> ▪ Registered ▪ MFRM=9 ▪ USB active 	25	25	36	mA
Idle—WCDMA	<ul style="list-style-type: none"> ▪ Registered ▪ DRX=8 ▪ USB active 	25	25	36	mA
Idle—LTE	<ul style="list-style-type: none"> ▪ Registered ▪ Paging cycle=256 ▪ USB active 	25	26	39	mA
Airplane mode ⁱ	<ul style="list-style-type: none"> ▪ Radio off ▪ USB active 	25	25	36	mA
Sleep					
Idle—GSM/GPRS/EDGE	<ul style="list-style-type: none"> ▪ Registered ▪ MFRM=9 ▪ USB-SS 	1.7	1.8	4	mA
Idle—WCDMA	<ul style="list-style-type: none"> ▪ Registered ▪ DRX=8 ▪ USB-SS 	1.6	1.8	4	mA
Idle—LTE	<ul style="list-style-type: none"> ▪ Registered ▪ Paging cycle=256 ▪ USB-SS 	1.7	1.8	6	mA

Table 3-10: RC7620, RC7620-1 Current Consumption Values (Continued)

Power State	Parameter	Min. ^a	Typ. ^a	Max. ^b	Units
Idle—LTE eDRX ^j	<ul style="list-style-type: none"> ▪ Period = 40.96 sec ▪ USB-SS 	1.5	1.8	4	mA
Airplane mode ⁱ	<ul style="list-style-type: none"> ▪ Radio off ▪ USB-SS 	1	1.3	4	mA
Low Power Mode					
PSM Dormant	Non-active	7	10	20	uA
OFF (VBATT_ON)	Non-active	3	6	10	uA
GNSS ^k					
GNSS	Acquisition (Airplane mode, cold start)	23	25	35	mA
	Tracking (Registered)	23	25	35	mA

- a. Input 3.7V, normal temperature
- b. Input 3.4V, 70°C
- c. Tx min.
- d. Tx max.
- e. At GSM conducted 4 slot max Tx output power, measured at peak current on supported DC range.
- f. At GSM conducted 4 slot max TX output power, measured at average current on supported DC range.
- g. At WCDMA conducted max Tx output power. (see [Table 3-33](#))
- h. Bandwidth 10 MHz, UP/DL RB=50, enable throughput, modulation:QPSK
- i. Radio is turned off and all interfaces setting are default without any external control connection.
- j. eDRX test condition: eDRX setting: at+cedrxs=1,4,"0011", eDRX period = 40.96 sec, PTW = 5.12 sec, DRX cycle = 64 ms, For details on AT commands, see Semtech RC76xx AT Command Reference.
- k. GNSS current consumption values are for the GNSS radio only. For total consumption, add the GNSS value to the consumption for the mode being used.

Table 3-11: RC7630, RC7630-1 Current Consumption Values

Power State	Parameter	Min. ^a	Typ. ^a	Max. ^b	Unit	
Active						
LTE Data transfer ^c	B1	691 ^d	743 ^e	891 ^e	mA	
	B3	650 ^d	697 ^e	802 ^e	mA	
	B5	665 ^d	712 ^e	758 ^e	mA	
	B7	700 ^d	744 ^e	804 ^e	mA	
	B8	669 ^d	718 ^e	813 ^e	mA	
	B18	693 ^d	738 ^e	869 ^e	mA	
	B19	676 ^d	725 ^e	836 ^e	mA	
	B21	507 ^d	558 ^e	661 ^e	mA	
Idle — LTE	<ul style="list-style-type: none"> ▪ Registered ▪ Paging cycle=256 	USB active	25	26	39	mA
Airplane mode ^f	Radio off	USB active	25	25	36	mA
Sleep						
Idle — LTE	<ul style="list-style-type: none"> ▪ Registered ▪ Paging cycle=256 	USB-SS	1.7	1.8	6	mA
Idle — LTE eDRX ^g	Period: 40.96 sec	USB-SS	1.5	1.8	4	mA
Airplane mode ^f	Radio off	USB-SS	1	1.3	4	mA
Low Power Mode						
PSM Dormant	Non-active		7	10	20	µA
OFF (VBATT_ON)	Non-active		3	6	10	µA
GNSS ^h						
Acquisition (Airplane mode, cold start)			23	25	35	mA
Tracking (Registered)			23	25	35	mA

- a. Input 3.7V, normal temperature
- b. Input 3.4V, 70°C
- c. Bandwidth 10 MHz, UP/DL RB=50, enable throughput, modulation: QPSK
- d. Tx min.
- e. Tx max.
- f. Radio is turned off and all interfaces setting are default without any external control connection.
- g. eDRX test condition: eDRX setting: at+cedrxs=1,4,"0011", eDRX period = 40.96 sec, PTW = 5.12 sec, DRX cycle = 64 ms, For details on AT commands, see Semtech RC76xx AT Command Reference.
- h. GNSS current consumption values are for the GNSS radio only. For total consumption, add the GNSS value to the consumption for the mode being used.

Table 3-12: RC7630J^a Current Consumption Values

Power State	Parameter	Min. ^b	Typ. ^b	Max. ^c	Unit	
Active						
LTE Data transfer ^d	B1	691 ^e	743 ^f	891 ^e	mA	
	B3	650 ^d	697 ^e	802 ^e	mA	
	B5	665 ^d	712 ^e	758 ^e	mA	
	B18	693 ^d	738 ^e	869 ^e	mA	
	B19	676 ^d	725 ^e	836 ^e	mA	
Idle — LTE	<ul style="list-style-type: none"> ▪ Registered ▪ Paging cycle=256 	USB active	25	26	39	mA
Airplane mode ^g	Radio off	USB active	25	25	36	mA
Sleep						
Idle — LTE	<ul style="list-style-type: none"> ▪ Registered ▪ Paging cycle=256 	USB-SS	1.7	1.8	6	mA
Idle — LTE eDRX ^h	Period: 40.96 sec	USB-SS	1.5	1.8	4	mA
Airplane mode ^f	Radio off	USB-SS	1	1.3	4	mA
Low Power Mode						
PSM Dormant	Non-active		7	10	20	uA
OFF (VBATT_ON)	Non-active		3	6	10	uA
GNSS ⁱ						
Acquisition (Airplane mode, cold start)			23	25	35	mA
Tracking (Registered)			23	25	35	mA

- a. Limited availability.
- b. Input 3.7V, normal temperature
- c. Input 3.4V, 70°C
- d. Bandwidth 10 MHz, UP/DL RB=50, enable throughput, modulation: QPSK
- e. Tx min.
- f. Tx max.
- g. Radio is turned off and all interfaces setting are default without any external control connection.
- h. eDRX test condition: eDRX setting: at+cdrxs=1,4,"0011", eDRX period = 40.96 sec, PTW = 5.12 sec, DRX cycle = 64 ms, For details on AT commands, see Semtech RC76xx AT Command Reference.
- i. GNSS current consumption values are for the GNSS radio only. For total consumption, add the GNSS value to the consumption for the mode being used.

Table 3-13: RC7612, RC7612-1 Current Consumption Values (Limited Availability)

Power State	Parameter	Min. ^a	Typ. ^a	Max. ^b	Units	
Active						
LTE Data transfer ^c	B2	210 ^d	700 ^e	980 ^e	mA	
	B4	210 ^d	710 ^e	1000 ^e	mA	
	B5	190 ^d	570 ^e	700 ^e	mA	
	B12	190 ^d	610 ^e	700 ^e	mA	
	B13	190 ^d	680 ^e	800 ^e	mA	
HSDPA Data transfer	B2	240	720	1000	mA	
	B4	250	740	1100	mA	
	B5	210	600	720	mA	
Idle — LTE	<ul style="list-style-type: none"> ▪ Registered ▪ Paging cycle=256 	USB active	25	26	39	mA
Idle — HSDPA	<ul style="list-style-type: none"> ▪ Registered ▪ DRX=8 	USB active	25	25	36	mA
Airplane mode ^f	Radio off	USB active	25	25	36	mA
Sleep						
Idle — LTE	<ul style="list-style-type: none"> ▪ Registered ▪ Paging cycle=256 	USB-SS	1.7	1.8	6	mA
Idle — HSDPA	<ul style="list-style-type: none"> ▪ Registered ▪ DRX=8 	USB active	1.6	1.8	4	mA
Idle — LTE eDRX ^g	Period: 40.96 sec	USB-SS	1.5	1.8	4	mA
Airplane mode ^f	Radio off	USB-SS	1	1.3	4	mA
Low Power Mode						
PSM Dormant	Non-active		7	10	20	uA
OFF (VBATT_ON)	Non-active		3	6	10	uA
GNSS ^h						
Acquisition (Airplane mode, cold start)			23	25	35	mA
Tracking (Registered)			23	25	35	mA

a. Input 3.7V, normal temperature

b. Input 3.4V, 70°C

c. Bandwidth 10 MHz, UP/DL RB=50, enable throughput, modulation:QPSK

d. Tx min.

e. Tx max.

f. Radio is turned off and all interfaces setting are default without any external control connection.

- g. eDRX test condition: eDRX setting: at+cedrxs=1,4,"0011", eDRX period = 40.96 sec, PTW = 5.12 sec, DRX cycle = 64 ms, For details on AT commands, see Semtech RC76xx AT Command Reference.
- h. GNSS current consumption values are for the GNSS radio only. For total consumption, add the GNSS value to the consumption for the mode being used.

3.3 RF

This section presents the module's WWAN RF interface, and defines the specifications for the LTE interface.

Note: RF sensitivity values presented in this section are for soldered-down modules. Sensitivity values decrease for modules installed in snap-in sockets, which might prevent the module from meeting 3GPP minimum specifications.

Semtech RC76xx is designed to be compliant with 3GPP Release 13 standards; refer to [Network Technology Specifications](#).

3.3.1 Supported RF Bands

Table 3-14: Supported RF Band

RAT	Band	RC7612 ^a	RC7612-1 ^a	RC7630	RC7630-1	RC7630 ^a	RC7620	RC7620-1	RC7611 RC7611D	RC7611-1 RC7611D-1
LTE	Category	4	1	4	1	4	4	1	4	1
	B1			Y	Y	Y	Y	Y		
	B2	Y	Y						Y	Y
	B3			Y	Y	Y	Y	Y		
	B4	Y	Y						Y	Y
	B5	Y	Y	Y	Y	Y			Y	Y
	B7			Y	Y		Y	Y		
	B8			Y	Y		Y	Y		
	B12	Y	Y						Y	Y
	B13	Y	Y						Y	Y
	B14								Y	Y
	B18			Y	Y	Y				
	B19			Y	Y	Y				
	B20						Y	Y		
	B21			Y	Y					
	B25								Y	Y
	B26								Y	Y
	B28						Y	Y		
B66								Y	Y	
B71								Y	Y	
UMTS	B1						Y	Y		
	B2	Y	Y							
	B4	Y	Y							
	B5	Y	Y							
	B8						Y	Y		
GSM/GPRS/EDGE	E-GSM 900						Y	Y		
	DCS 1800						Y	Y		

Table 3-14: Supported RF Band (Continued)

RAT	Band	RC7612 ^a	RC7612-1 ^a	RC7630	RC7630-1	RC7630J ^a	RC7620	RC7620-1	RC7611 RC7611D	RC7611-1 RC7611D-1
GNSS	GPS	Y ^b	Y ^b	Y ^b	Y ^b	Y ^b	Y ^b	Y ^b	Y ^b	Y ^b
	GLONASS									
	Galileo									
	BeiDou									
	QZSS			Y	Y	Y				

- a. Limited Availability
- b. SKU-dependent

3.3.2 LTE RF Interface

This section presents the LTE RF specification for Semtech RC76xx modules.

3.3.2.1 Tx Output Power

The module’s LTE maximum transmitter output power is specified in [Table 3-15](#).

Table 3-15: RC7611, RC7611-1, RC7611D, RC7611D-1, RC7612^a, RC7612-1^a Conducted Tx Max Output Power Tolerances—LTE^b

RF Band	Operating Condition	Min	Typ	Max	Units	Notes
B2	Normal (25°C)	21	23	24	dBm	Power class 3
B4	Normal (25°C)	21	23	24	dBm	Power class 3
B5	Normal (25°C)	21	23	24	dBm	Power class 3
B12	Normal (25°C)	21	23	24	dBm	Power class 3
B13	Normal (25°C)	21	23	24	dBm	Power class 3
B14	Normal (25°C)	21	23	24	dBm	Power class 3
B25	Normal (25°C)	21	23	24	dBm	Power class 3
B26	Normal (25°C)	21	23	24	dBm	Power class 3
B66	Normal (25°C)	21	23	24	dBm	Power class 3
B71	Normal (25°C)	21	23	24	dBm	Power class 3

- a. Limited Availability
- b. Stated typical power tolerance satisfies 3GPP TS 36.521-1 requirements for normal (25°C).

Table 3-16: RC7620, RC7620-1 Conducted Tx Max Output Power Tolerances—LTE^a

RF Band	Operating Condition	Min	Typ	Max	Units	Notes
B1	Normal (25°C)	21	23	24	dBm	Power class 3
B3	Normal (25°C)	21	23	24	dBm	Power class 3
B7	Normal (25°C)	21	23	24	dBm	Power class 3
B8	Normal (25°C)	21	23	24	dBm	Power class 3
B20	Normal (25°C)	21	23	24	dBm	Power class 3
B28	Normal (25°C)	21	23	24	dBm	Power class 3

a. Stated typical power tolerance satisfies 3GPP TS 36.521-1 requirements for normal (25°C).

Table 3-17: RC7630, RC7630-1 Conducted Tx Max Output Power Tolerances—LTE^a

RF Band	Operating Condition	Min	Typ	Max	Units	Notes
B1	Normal (25°C)	21	23	24	dBm	Power class 3
B3	Normal (25°C)	21	23	24	dBm	Power class 3
B5	Normal (25°C)	21	23	24	dBm	Power class 3
B7	Normal (25°C)	21	23	24	dBm	Power class 3
B8	Normal (25°C)	21	23	24	dBm	Power class 3
B18	Normal (25°C)	21	23	24	dBm	Power class 3
B19	Normal (25°C)	21	23	24	dBm	Power class 3
B21	Normal (25°C)	21	23	24	dBm	Power class 3

a. Stated typical power tolerance satisfies 3GPP TS 36.521-1 requirements for normal (25°C).

Table 3-18: RC7630J^{a,b} Conducted Tx Max Output Power Tolerances—LTE

RF Band	Operating Condition	Min	Typ	Max	Units	Notes
B1	Normal (25 °C)	21	23	24	dBm	Power class 3
B3	Normal (25 °C)	21	23	24	dBm	Power class 3
B5	Normal (25 °C)	21	23	24	dBm	Power class 3
B18	Normal (25 °C)	21	23	24	dBm	Power class 3
B19	Normal (25 °C)	21	23	24	dBm	Power class 3

- a. Stated typical power tolerance satisfies 3GPP TS 36.521-1 requirements for normal (25 °C).
- b. Limited availability.

3.3.2.2 Rx Sensitivity

The module’s LTE receiver sensitivity is specified in the following tables.

Table 3-19: RC7611, RC7611-1, RC7611D, RC7611D-1, RC7612^a, RC7612-1^a Conducted Rx Sensitivity—LTE Bands^b

LTE Bands		+25 °C (dBm)			Class A (dBm)			SIMO (Worst case) ^c
		Primary (Typical)	Secondary (Typical)	SIMO (Typical)	Primary (Typical)	Secondary (Typical)	SIMO (Typical)	
B2	Full RB BW: 10 MHz ^d	-98	-98	-100	-97	-97.5	-99.5	-94.3
B4		-98	-97.5	-99.5	-97	-96.5	-98.5	-96.3
B5		-99	-98	-100.5	-98	-97	-99.5	-94.3
B12		-97	-96	-99	-96	-95.5	-98	-93.3
B13		-97.5	-95	-99	-96	-94	-98	-93.3
B14		-96.5	-97	-99.5	-96.5	-96	-98.5	-93.3
B25		-98	-98	-100	-97	-97.5	-99.5	-92.8
B26		-99	-98	-100.5	-98	-97	-99.5	-93.8
B66		-98	-98	-100	-97	-97	-99	-95.8
B71		-98	-97.5	-100	-96.5	-97	-99	-93.5

- a. Limited Availability
- b. RF sensitivity values are for soldered-down modules.
- c. Per 3GPP specification.
- d. Sensitivity values scale with bandwidth: $x_MHz_Sensitivity = 10_MHz_Sensitivity - 10 \times \log(10\text{ MHz}/x_MHz)$
Note: Bandwidth support is dependent on firmware version

Table 3-20: RC7620, RC7620-1 Conducted Rx Sensitivity—LTE Bands^a

LTE Bands		+25 °C (dBm)			Class A (dBm)			SIMO (Worst case) ^b
		Primary (Typ.)	Secondary (Typ.)	SIMO (Typ.)	Primary (Typ.)	Secondary (Typ.)	SIMO (Typ.)	
B1	Full RB BW: 10 MHz ^c	-97.5	-96.5	-100	-96.5	-96	-99	-96.3
B3		-97	-97	-100	-96.5	-97	-99	-93.3
B7		-95	-96	-99	-94.5	-95	-98	-94.3
B8		-98	-97	-100	-97.5	-96	-99	-93.3
B20		-97	-96	-99	-97	-95	-99	-93.3
B28		-96	-93	-98.5	-95.5	-92	-98	-94.8

- a. RF sensitivity values are for soldered-down modules.
- b. Per 3GPP specification.
- c. Sensitivity values scale with bandwidth: $x_MHz_Sensitivity = 10_MHz_Sensitivity - 10 \times \log(10\text{ MHz}/x_MHz)$
Note: Bandwidth support is dependent on firmware version

Table 3-21: RC7630, RC7630-1 Conducted Rx Sensitivity—LTE Bands^a

LTE Bands		+25 °C (dBm)			Class A (dBm)			SIMO (Worst case) ^b
		Primary (Typical)	Secondary (Typical)	SIMO (Typical)	Primary (Typical)	Secondary (Typical)	SIMO (Typical)	
B1	Full RB BW: 10 MHz ^c	-98.5	-97.5	-101	-97	-96.5	-100	-96.3
B3		-98.5	-98	-100.5	-97.5	-96.5	-99.5	-93.3
B5		-98.5	-99	-101	-97	-97	-100	-94.3
B7		-97	-97	-99	-96	-96	-98	-94.3
B8		-98.5	-99	-101	-97.5	-98	-100	-93.3
B18		-98.5	-99	-101	-97.5	-98	-100	-96.3
B19		-98.5	-99	-101	-97.5	-98	-100	-96.3
B21		-98.5	-100	-101	-97	-99	-100	-96.3

- a. RF sensitivity values are for soldered-down modules.
- b. Per 3GPP specification
- c. Sensitivity values scale with bandwidth: $x_MHz_Sensitivity = 10_MHz_Sensitivity - 10 \times \log(10\text{ MHz}/x_MHz)$
Note: Bandwidth support is dependent on firmware version.

Table 3-22: RC7630J^a Conducted Rx Sensitivity—LTE Bands^b

LTE Bands		+25 °C (dBm)			Class A (dBm)			SIMO (Worst case) ^c
		Primary (Typical)	Secondary (Typical)	SIMO (Typical)	Primary (Typical)	Secondary (Typical)	SIMO (Typical)	
B1	Full RB BW: 10 MHz ^d	-98.5	-97.5	-101	-97	-96.5	-100	-96.3
B3		-98.5	-98	-100.5	-97.5	-96.5	-99.5	-93.3
B5		-98.5	-99	-101	-97	-97	-100	-94.3
B18		-98.5	-99	-101	-97.5	-98	-100	-96.3
B19		-98.5	-99	-101	-97.5	-98	-100	-96.3

- a. Limited availability.
- b. RF sensitivity values are for soldered-down modules.
- c. Per 3GPP specification
- d. Sensitivity values scale with bandwidth: $x_MHz_Sensitivity = 10_MHz_Sensitivity - 10 \times \log(10\text{ MHz}/x_MHz)$
Note: Bandwidth support is dependent on firmware version.

3.3.3 GSM / GPRS / EDGE RF Interface

This section presents the GSM / GPRS / EDGE RF specifications for Semtech RC7620 modules.

3.3.3.1 GSM / GPRS / EDGE Tx Output Power

Table 3-23: Conducted Tx Max Output Power Tolerances—GSM / GPRS / EDGE^a

RF Band	Min	Typ	Max	Units	Notes
E-GSM 900	31	33	34	dBm	GMSK mode (Class 4; 2 W, 33 dBm)
	24.5	27	29.5	dBm	8PSK mode (Class E2; 0.5 W, 27 dBm)
DCS 1800	28	30	31	dBm	GMSK (Class 1; 1W, 30 dBm)
	23.5	26	28.5	dBm	8PSK (Class E2; 0.4W, 26 dBm)

- a. Stated power tolerance satisfy 3GPP TS 51.010-1 requirements for normal (25 °C) conditions.

3.3.3.2 GSM / GPRS / EDGE Rx Sensitivity

Table 3-24: Conducted Rx Sensitivity—GSM / GPRS / EDGE Bands^a

	@ +25°C (dBm) ^b	@ Class A (dBm) ^c
E-GSM 900	-109	-108
DCS 1800	-109	-108

- a. Stated power tolerance satisfy 3GPP TS 51.010-1 requirements for normal (25°C) and Class A (extreme) conditions.
- b. Typical value
- c. Typical value, tested at Class A extreme condition

3.3.4 WCDMA RF Interface

This section presents the WCDMA RF specification for Semtech RC76xx modules.

3.3.4.1 WCDMA Tx Output Power

The module’s WCDMA maximum transmitter output power is specified in the following table.

Table 3-25: RC7612, RC7612-1 Conducted Tx Max Output Power Tolerances—WCDMA

RF Band	Min	Typ ^a	Max	Units	Notes
B2	21.5	23	24	dBm	Power class 3 bis
B4	21.5	23	24	dBm	Power class 3 bis
B5	21.5	23	24	dBm	Power class 3 bis

- a. Stated typical power tolerance satisfies 3GPP TS 34.121-1 requirements for normal (25°C) conditions.

Table 3-26: RC7620, RC7620-1 Conducted Tx Max Output Power Tolerances—WCDMA

RF Band	Min	Typ ^a	Max	Units	Notes
B1	21.5	23	24	dBm	Power class 3 bis
B8	21.5	23	24	dBm	Power class 3 bis

- a. Stated typical power tolerance satisfies 3GPP TS 34.121-1 requirements for normal (25°C) conditions.

3.3.4.2 RC76xx WCDMA Rx Sensitivity (Limited Availability)

The module’s WCDMA receiver sensitivity is specified in the following table.

Table 3-27: RC7612, RC7612-1 Conducted Rx Sensitivity—WCDMA Bands^{a,b}

Band	+25 °C		Class A		Standard Limit (dBm)	Notes
	Primary (dBm) ^c	Secondary (dBm) ^c	Primary (dBm) ^d	Secondary (dBm) ^d		
B2	-109	-109	-109	-109	-104	CS 0.1% BER 12.2 kbps Reference Measurement Channel
B4	-110	-110	-110	-110	-106	
B5	-110	-109	-109	-109	-104	

- a. Stated sensitivity values satisfy 3GPP TS 34.121-1 V8.10.0 requirements for normal (25 °C) and Class A (extreme) conditions.
- b. RF sensitivity values are for soldered-down modules
- c. Typical value.
- d. Typical value, tested at Class A extreme temperature.

Table 3-28: RC7620, RC7620-1 Conducted Rx Sensitivity—WCDMA Bands^{a,b}

Band	+25 °C		Class A		Standard Limit (dBm)	Notes
	Primary (dBm) ^c	Secondary (dBm) ^c	Primary (dBm) ^d	Secondary (dBm) ^d		
B1	-108	-108	-107	-107	-106	CS 0.1% BER 12.2 kbps Reference Measurement Channel
B8	-110	-109	-109	-109	-103	

- a. Stated sensitivity values satisfy 3GPP TS 34.121-1 V8.10.0 requirements for normal (25 °C) and Class A (extreme) conditions.
- b. RF sensitivity values are for soldered-down modules
- c. Typical value.
- d. Typical value, tested at Class A extreme temperature.

3.3.5 WWAN Antenna Interface

The following table defines the WWAN antenna interfaces of the Semtech RC76xx modules.

Table 3-29: WWAN Antenna Interface Pins

Pin #	Signal name	Direction	Function
30	GND		Diversity Antenna Ground
31	RF_DIV	Input	Diversity Antenna Interface
32	GND		Diversity Antenna Ground
48	GND		Primary Antenna Ground
49	RF_MAIN	Input/Output	Primary Antenna Interface
50	GND		Primary Antenna Ground

Table 3-29: WWAN Antenna Interface Pins (Continued)

Pin #	Signal name	Direction	Function
111	GND		Diversity Antenna Ground
113	GND		Diversity Antenna Ground
136	GND		Primary Antenna Ground
139	GND		Primary Antenna Ground

Note: For the routing of ground and RF signal, see [Figure 5-4](#) and [Figure 5-5](#).

3.3.5.1 WWAN Antenna Recommendations

[Table 3-30](#) defines the key characteristics to consider for antenna selection.

Table 3-30: Antenna Recommendations^a

Parameter		Recommendations	Notes
Antenna system		External multi-band antenna system	Dual WWAN antennas for diversity (Antenna 1 / Antenna 2) ^b
Operating bands	RC7611, RC7611-1, RC7611D, RC7611D-1	617– 798 MHz	Operating bands depend on the module’s supported bands/modes.
		814 – 894 MHz	
		1710 – 2200 MHz	
	RC7620, RC7620-1	703 – 960 MHz	
		1710 – 1980 MHz	
		2110 – 2170 MHz	
		2500 – 2690 MHz	
	RC7630, RC7630-1	815 – 960 MHz	
		1710 – 2170 MHz	
		1447 – 1511 MHz	
		2500 – 2690 MHz	
	RC7630J ^c	815-894 MHz	
		1710-2170 MHz	
RC7612, RC7612-1 ^c	617– 798 MHz		
	814 – 894 MHz		
	1710 – 2200 MHz		

Table 3-30: Antenna Recommendations^a (Continued)

Parameter	Recommendations	Notes
VSWR	< 2.5:1 (worst case)	<ul style="list-style-type: none"> On all bands including band edges Applies to both antennas
Total radiated efficiency	> 50% on all bands	<ul style="list-style-type: none"> Measured at the RF connector. Applies to both antennas Includes mismatch losses, losses in the matching circuit, and antenna losses, excluding cable loss. Semtech recommends using antenna efficiency as the primary parameter for evaluating the antenna system. Peak gain is not a good indication of antenna performance when integrated with a host device (the antenna does not provide omnidirectional gain patterns). Peak gain can be affected by antenna size, location, design type, etc. — the antenna gain pattern remains fixed unless one or more of these parameters change.
Radiation patterns	Nominally omnidirectional radiation pattern in azimuth plane.	
Envelope correlation coefficient between Antenna 1 and Antenna 2	<ul style="list-style-type: none"> < 0.4 on B5 Rx (869–894 MHz), B12 Rx (729–746 MHz), B13 Rx (746–756 MHz), B14 Rx (758–768 MHz), B26 Rx (859–894 MHz) and B71 Rx (617–652 MHz) < 0.2 on B2 Rx (1930–1990 MHz), B4 Rx (2110–2155 MHz), B25 Rx (1930–1995 MHz) and B66 Rx (2110–2200 MHz) 	
Mean Effective Gain (MEG)	≥ -3 dBi	
Mean Effective Gain Imbalance—Antenna 1 and Antenna 2 (MEG1 / MEG2)	< 6 dB for diversity operation	
Maximum antenna gain	Must not exceed antenna gains due to RF exposure and ERP/EIRP limits, as listed in the module’s FCC grant.	

Table 3-30: Antenna Recommendations^a (Continued)

Parameter		Recommendations	Notes
Isolation between Antenna 1 and Antenna 2 (S21)		> 10 dB	<ul style="list-style-type: none"> ▪ If antennas can be moved, test all positions for both antennas. ▪ Unless otherwise specified, this isolation requirement must be maintained for optimum operation. ▪ Make sure all other wireless devices (Bluetooth or WLAN antennas, etc.) are turned OFF to avoid interference.
Maximum voltage applied to antenna		6.3 VDC	
Power handling		> 1 W on all bands > 2 W RF power on low bands	<ul style="list-style-type: none"> ▪ Measure power endurance over 4 hours (estimated talk time) using a 2 W CW signal — set the CW test signal frequency to the middle of the PCS Tx band (1880 MHz for PCS). ▪ Visually inspect device to ensure there is no damage to the antenna structure and matching components. ▪ VSWR/TIS/TRP measurements taken before and after this test must show similar results.

- These worst-case VSWR figures for the transmitter bands may not guarantee RSE levels to be within regulatory limits. The device alone meets all regulatory emissions limits when tested into a cabled (conducted) 50Ω system. With antenna designs with up to 2.5:1 VSWR or worse, the radiated emissions could exceed limits. The antenna system may need to be tuned in order to meet the RSE limits as the complex match between the module and antenna can cause unwanted levels of emissions. Tuning may include antenna pattern changes, phase/delay adjustment, passive component matching.
- Antenna 1 — Primary (RF_MAIN), Antenna 2 — Secondary (RF_DIV) (Diversity)
- Limited availability.

3.4 GNSS

The Semtech RC76xx includes Global Navigation Satellite System (GNSS) capabilities via the QUALCOMM IZat™ Gen8C Engine (formerly gpsOne), capable of operation in assisted and standalone GNSS modes (GPS/Galileo/GLONASS/BeiDou/QZSS).

Note: The Semtech RC76xx modules are not affected by the 6 April 2019 rollover. Software modifications extend the GPS rollover date to 12 December 2032.

3.4.1 Characteristics

The GNSS implementation supports GPS L1, Galileo E1, BeiDou-B1 and GLONASS L1 FDMA operation.

Table 3-31: GNSS Characteristics^a

Parameter		Value
Sensitivity ^b	Standalone or MS-based tracking sensitivity	-160 dBm
	Cold start acquisition sensitivity	-145 dBm
	MS-assisted acquisition sensitivity	-158 dBm
Accuracy in open sky (1 Hz tracking)		< 2 m CEP-50
Satellite channels available ^c	Acquisition	118
	Simultaneous tracking	40
Support for predicted orbits		Yes
Predicted orbit CEP-50 accuracy		5 m
Standalone Time To First Fix (TTFF)	Hot	1 s
	Warm	29 s
	Cold	32 s
Altitude (max)		18,288 m (60,000 ft)
Velocity (max)		1,852 km/h (1150.8 mph)
Acceleration (max)		20 m/s ²
GNSS message protocols		NMEA
Recommended signal power for GPS input		Below -120 dBm
Maximum allowed GPS input		-116 dBm (if noise figure ≤ 3 is achieved)

- a. Acquisition / tracking sensitivity performance figures in conducted mode assume a 2.5 dB noise figure.
- b. GNSS sensitivity may degrade for modules installed in snap-in sockets.
- c. Resources are dynamically assigned and not constellation-specific.

3.4.2 GNSS Antenna Interface

The GNSS antenna interface is defined in [Table 3-32](#).

Table 3-32: GNSS Antenna Interface Pads

Pad	Name	Direction ^a	Function
37	GND		GNSS Antenna Ground
38	RF_GNSS	Input	GNSS Antenna Interface
39	GND		GNSS Antenna Ground

Table 3-32: GNSS Antenna Interface Pads (Continued)

Pad	Name	Direction ^a	Function
125	GND		GNSS Antenna Ground
128	GND		GNSS Antenna Ground

a. Signal direction with respect to the module.

Note: For the routing of ground and RF signal, see [Figure 5-4](#) and [Figure 5-5](#).

3.4.3 Antenna Recommendations

[Table 3-33](#) defines the key characteristics to consider for antenna selection.

Table 3-33: GNSS Standalone Antenna Recommendations^a

Parameter	Recommendations	Notes
Frequency range	<ul style="list-style-type: none"> Wide-band GPS, Galileo, GLONASS, and BeiDou: 1559–1606 MHz recommended Narrow-band GPS: 1575.42 MHz ± 2.046 MHz minimum 	
Field of view (FOV) ^b	<ul style="list-style-type: none"> Omni-directional in azimuth -45° to +90° in elevation 	
Polarization (average Gv/Gh)	> 0 dB	Vertical linear polarization is sufficient.
Free space average gain (Gv+Gh) over FOV	> -6 dBi (preferably > -3 dBi)	Gv and Gh are measured and averaged over -45° to +90° in elevation, and ±180° in azimuth.
Gain	<ul style="list-style-type: none"> Maximum gain and uniform coverage in the high elevation angle and zenith. Gain in azimuth plane is not desired. 	
Average 3D gain	> -5 dBi	
Isolation between GNSS and RF Antenna	> 20 dB in all uplink bands	
Typical VSWR	< 2.5:1	
Polarization	Any other than LHCP (left-hand circular polarized) is acceptable.	Type of antenna and polarization (RHCP/linear) to be implemented is a matter of consideration based on specific end application.
Maximum voltage applied to antenna	6.3 VDC	
700 MHz harmonic ^{b,c}	< -56 dBm (input jammer 787.76 MHz at -25 dBm and measure the harmonic tone at 1575.42 MHz)	This specification is for B13 and B14 coexistence.

Table 3-33: GNSS Standalone Antenna Recommendations^a (Continued)

Parameter	Recommendations	Notes
IIP2 ^{b,c}	> 45 dBm (Input jammers at 824.6 MHz with level -25 dBm and 2400 MHz with level -32 dBm and measure output IM2 at 1575.4 MHz)	Out of band
IIP3 ^{b,c}	> 2 dBm (Input jammers at 1712.7 MHz with level -20 dBm and 1850 MHz with level -65 dBm and measure output IM3 at 1575.4 MHz)	Out of band
Input 1 dB power compression point ^{b,c}	> -10 dBm	
Out of band rejection for an active antenna		
663–716 MHz	> 50 dB	
777–798 MHz	> 50 dB	
814–915 MHz	> 40 dB	50 dB is preferred
925–960 MHz	> 30 dB	50 dB is preferred
1427–1463 MHz	> 35 dB	
1710–1785 MHz	> 35 dB	
1850–1980 MHz	> 40 dB	
2010–2025 MHz	> 40 dB	
2305–2315 MHz	> 40 dB	
2401–2483 MHz	> 40 dB	
2500–2570 MHz	> 35 dB	

- a. All values are preliminary and subject to change.
- b. Noise figure: < 2dB, System gain: [14-17dB].

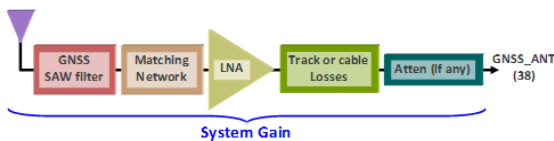

- c. For the LNA used by an active antenna

3.5 Electrical Specifications

This section provides details of key electrical specifications.

3.5.1 Absolute Maximum Ratings

Warning: *If these parameters are exceeded, even momentarily, damage may occur to the device. In addition, extended application of Absolute Maximum Rating conditions to the device may reduce device reliability.*

Note: Operation above the maximum specified operating voltage (see [Table 3-3](#)) is not recommended, and specified typical performance or functional operation of the device is neither implied nor guaranteed.

Table 3-34: Absolute Maximum Ratings

Parameter		Min	Typ	Max	Units
Power supply voltages					
VBAT_BB	Power Supply Input	0	-	6.0	V
VBAT_RF	Power Supply Input	0	-	5.5	V
VDD_Px (low-voltage (1.8V) operation)	Digital pad circuits	-0.5	-	2.3	V
VDD_Px (high-voltage (2.85V) operation)	Digital pad circuits	-0.5	-	3.35	V
USB signal pins					
USB_D+	High-speed USB data plus	-	-	3.6	V
USB_D-	High-speed USB data minus	-	-	3.6	V
USB_VBUS	High-speed USB bus voltage	-	-	5.25	V
Thermal conditions					
TS	Storage temperature	-40		85	°C
TJ	Junction temperature ^a	-	-	100	°C
Maximum voltage applied to antenna interface pins					
VANT	RF_MAIN	-		6.3	Vdc
	RF_DIV	-		6.3	Vdc
	RF_GNSS	-		6.3	Vdc
ESD ratings					
See EMC and ESD Recommendations .					

a. Refer to APN 2174283 Semtech - RC76xx - Thermal Model

3.5.2 Digital I/O Characteristics

The I/O characteristics for supported digital interfaces are described in:

- [Table 3-35](#)— GPIOs, UART, ANT_CNTL, TX_ON, PCM/I²S, SPI, I2C, W_DISABLE_N, TP1, WAKE_ON_WWAN, and DR_SYNC signals
- [Table 3-36](#)— GPIO8 and GPIO28
- [Table 3-37](#)— UIM signals

- [Table 3-38](#) — GPIO6, SAFE_PWR_REMOVE, Clocks

Table 3-35: Digital I/O Characteristics — $V_{DD_IO} = 1.80\text{ V}$ (nominal)

Parameter	Notes	Min	Max	Units
V_{IH}	High level input voltage	$0.65 \times V_{DD_IO}$	$V_{DD_IO} + 0.3$	V
V_{IL}	Low level input voltage	-0.3	$0.35 \times V_{DD_IO}$	V
V_{SHYS}	Schmitt hysteresis voltage	100	-	mV
V_{OH}	High level output voltage	$V_{DD_IO} - 0.45$	V_{DD_IO}	V
V_{OL}	Low level output voltage	0	0.45	V
R_P	Pull up/down resistance	55	390	k Ω
R_K	Keeper resistance	30	150	k Ω
I_{IH}	Input high leakage current ^a	-	1	μ A
I_{IL}	Input low leakage current ^b	-1	-	μ A
C_{IN}	Input capacitance ^c	-	5	pF
I_{PIN}	Current per pin	-	16	mA

- Pin voltage = V_{DD_IO} . For keeper pins, pin voltage = $V_{DD_IO} - 0.45$.
- Pin voltage = GND and supply = V_{DD_IO} . For keeper pins, pin voltage = 0.45 V and supply = V_{DD_IO}
- Input capacitance is guaranteed by design.

Table 3-36: GPIO8 and GPIO28 Digital I/O Characteristics — $V_{DD_IO} = 1.80\text{ V}$ (nominal)

Parameter	Notes	Min	Max	Units
V_{IH}	High level input voltage	$0.65 \times V_{DD_IO}$	$V_{DD_IO} + 0.3$	V
V_{IL}	Low level input voltage	-0.3	$0.35 \times V_{DD_IO}$	V
V_{SHYS}	Schmitt hysteresis voltage	165	-	mV
V_{OH}	High level output voltage	$0.8 \times V_{DD_IO}$	V_{DD_IO}	V
V_{OL}	Low level output voltage	0	$0.2 \times V_{DD_IO}$	V
R_P	Pull up/down resistance	10	50	k Ω
R_K	Keeper resistance	10	50	k Ω
I_{IH}	Input high leakage current ^a	-	1	μ A
I_{IL}	Input low leakage current ^b	-1	-	μ A
I_{PIN}	Current per pin	-	16	mA
C_{IN}	Input capacitance ^c	-	5	pF

- Pin voltage = V_{DD_IO}
- Pin voltage = GND and supply = V_{DD_IO}
- Input capacitance is guaranteed by design.

Table 3-37: UIM Characteristics — Dual-voltage $V_{UIM_IO} = 1.80\text{ V}$ or 2.85 V (nominal)

Parameter	Notes	Min	Max	Units	
Common to UIM dual-voltage pads (1.8 V / 2.85 V)					
V_{IH}	High level input voltage	CMOS/Schmitt	$0.7 \times V_{UIM_IO}$	$V_{UIM_IO} + 0.3$	V
V_{IL}	Low level input voltage	CMOS/Schmitt	-0.3	$0.2 \times V_{UIM_IO}$	V
V_{SHYS}	Schmitt hysteresis voltage		100	-	mV
V_{OH}	High level output voltage	CMOS, at pin-rated drive strength	$0.8 \times V_{UIM_IO}$	V_{UIM_IO}	V
V_{OL}	Low level output voltage	CMOS, at pin-rated drive strength	0	0.4	V
R_P	Pull resistance	Pull-up and pull-down	10	100	k Ω
R_K	Keeper resistance		10	100	k Ω
$C_{I/O}$	I/O capacitance ^a		-	5	pF
Common to UIM pads at 2.85 V only					
I_{IH}	Input high leakage current ^b	No pull-down	-	10	μ A
I_{IL}	Input low leakage current ^c	No pull-up	-10	-	μ A
Common to UIM pads at 1.8 V only					
I_{IH}	Input high leakage current ^b	No pull-down	-	2	μ A
I_{IL}	Input low leakage current ^c	No pull-up	-2	-	μ A

a. Input capacitance is guaranteed by design.

b. Pin voltage = V_{UIM_IO}

c. Pin voltage = GND and supply = V_{UIM_IO}

Table 3-38: GPIO6, SAFE_PWR_REMOVE, Clocks — $V_{DD_IO} = 1.80\text{ V}$ (nominal)

Parameter	Notes	Min	Max	Units	
V_{IH}	High-level input voltage	CMOS/Schmitt	$0.65 \times V_{DD_IO}$	$V_{DD_IO} + 0.3$	V
V_{IL}	Low-level input voltage	CMOS/Schmitt	-0.3	$0.35 \times V_{DD_IO}$	V
V_{SHYS}	Schmitt hysteresis voltage		15	-	mV
I_L	Input leakage current ^a	$V_{DD_IO} = \text{max}, V_{IN} = 0\text{ V to } V_{DD_IO}$	-0.20	+0.20	μ A
V_{OH}	High-level output voltage	$I_{OUT} = I_{OH}$	$V_{DD_IO} - 0.45$	V_{DD_IO}	V
V_{OL}	Low-level output voltage	$I_{OUT} = I_{OL}$	0	0.45	V
I_{OH}^c	High-level output current	$V_{OUT} = V_{OH}$	0.15	0.9	mA
I_{OL}^c	Low-level output current	$V_{OUT} = V_{OL}$	0.15	0.9	mA
I_{OH_XO}	High-level output current	XO digital clock outputs only	6	-	mA
I_{OL_XO}	Low-level output current	XO digital clock outputs only	-	-6	mA

Table 3-38: GPIO6, SAFE_PWR_REMOVE, Clocks — $V_{DD_IO} = 1.80\text{ V}$ (nominal) (Continued)

Parameter		Notes	Min	Max	Units
C_{IN}	Input capacitance ^b		-	5	pF
I_{IN}^c	Input current	Internal pull-up	-	30	mA
		Internal pull-down ^d	-	10	uA

- a. The GPIO6 pin complies with the input leakage specification only when configured as a digital input.
b. Input capacitance is guaranteed by design.
c. For GPIO6 only.
d. The default status of the internal pull down is 10Ω .

3.5.3 Internal Devices

Table 3-39 summarizes the frequencies generated within the Semtech RC76xx. This table is provided for reference only to the device integrator.

Table 3-39: Internal Device Frequencies

Subsystem / Feature	Frequency	Units
Real Time Clock	32.768	kHz
PCM Audio Interface (PCM Master Mode)	256 / 512 / 1024 / 2048 / 4096	kHz
I ² C Interface	100	kHz
PMIC power supplies switching frequency	1.6	MHz
Fundamental clock	19.2	MHz
PLL	<ul style="list-style-type: none"> ▪ PLL0: 800.0000 ▪ PLL1: 614.4000 ▪ PLL2: 480.0000 ▪ PLL3: 600.6000 ▪ PLL4: 576.0000 ▪ PLL5: 691.2000 ▪ PLL6: Varies (1.2 GHz max) 	MHz
SPI	38	MHz
USB	480	Mb/s

3.6 Processing

3.6.1 Application Core

The Application Core is based on a Cortex A7 32-bit RISC architecture core. It has the following main characteristics:

- Up to 1.3 GHz operation
- Cache:
 - L1: Instruction (32 kB) and Data (32 kB)
 - L2: 256 kB

Refer to [Interfaces Specifications](#) for the list of interfaces supported by this core.

3.6.2 Embedded Memory

The Semtech RC76xx module includes Flash and RAM embedded memory as detailed in [Table 3-40](#).

Refer to the latest customer release note for any changes regarding embedded memory.

Table 3-40: Embedded Memory Details

Type	Details	Size
Flash	Total	128 MB
	Reserved for Application processor	8 MB
	Minimum number of write cycles	100,000
RAM	Total	128 MB
	Reserved for Application processor	40 MB

The application processor memory is dedicated to the ThreadX platform, including Semtech Proprietary Applications.

3.6.2.1 Flash Memory

Flash memory is partitioned for use by various elements. Partition APPS can be used by the ThreadX firmware, framework and application. The remaining partitions are reserved for internal use.

Table 3-41: Flash Memory Partitions

Partition: ("sbl") Usage: System bootloader (Internal use)
Partition: ("mibib") Usage: Internal use
Partition: ("backup") Usage: Internal use
Partition: ("security") Usage: Internal use
Partition: ("persist") Usage: Internal use
Partition: ("efs2") Usage: Internal use
Partition: ("tz") Usage: Internal use
Partition: ("devcfg") Usage: Internal use
Partition: ("sec") Usage: Internal use

Table 3-41: Flash Memory Partitions (Continued)

Partition: ("mba") Usage: Internal use
Partition: ("acdb") Usage: Internal use
Partition: ("rpm") Usage: Internal use
Partition: ("qdsp") Usage: Internal use
Partition: ("apps") Usage: ThreadX system
Partition: ("slot_0") Usage: Internal use
Partition: ("efs2apps") Usage: Internal use

Follow these instructions to display partition sizes and to determine whether a customer firmware will fit:

1. Connect to the RC module.
2. Use **Trace32** command. Partition sizes are listed in the 'Start block' and 'Limit' columns.

```
MIBIB partition opened ptr = 0x216410 ::
Partition      Start Block      Limit      Page 0
-----
0:SBL          0x0              0xa        Written
0:MIBIB        0xa              0x14       Written
0:BACKUP       0x14             0x48       Empty
0:SECURITY     0x48             0x59       Empty
0:PERSIST      0x59             0x69       Empty
0:EFS2         0x69             0xd7       Written
0:TZ           0xd7             0xe9       Written
0:DEVCFG       0xe9             0xec       Written
0:APDP         0xec             0xef       Empty
0:MBA          0xef             0xf4       Written
0:ACDB         0xf4             0xf8       Written
0:RPM          0xf8             0xfc       Written
0:QDSP         0xfc             0x253      Written
0:APPS         0x253            0x297      Written
0:SLOT_0       0x297            0x3d2      Empty
0:EFS2APPS     0x3d2            0x400      Written

===== Done =====
```

3. When building an image, use the **swicwe** command to display the sizes of the image components to ensure that they can fit in the associated partitions. For example:

Type	Size (Excluding Header)	Product	Compress	Version
*SPKG	46239368	9X28	0	INTERNAL_?_SWI9X07H_00.01.01.00_?_?_?
*BOOT	408820	9X28	0	SWI9X07H_00.01.01.00 000000 jenkins 2019/10/18 11:04:20
SBL1	408420	9X28	0	SWI9X07H_00.01.01.00 000000 jenkins 2019/10/18 11:04:20
*MODM	41054276	9X28	0	SWI9X07H_00.01.01.00 000000 jenkins 2019/10/18 11:04:20
TZON	934800	9X28	0	SWI9X07H_00.01.01.00 000000 jenkins 2019/10/18 11:04:20

3.6.3 Recovery Mechanism

The Semtech RC76xx has the capability to automatically detect and recover from various corruption scenarios (for example, corruption may occur when power is abruptly removed from the module).

A backup of the configuration stored in the file system is created before the RC76xx leaves the Semtech factory. The file system backup can be updated at customer factories using **AT!NVBACKUP**. If a file system corruption is detected, the stored backups are checked and the most recent backup is automatically restored.

To avoid the potential for memory corruption, make sure to always follow the proper power off procedure before removing power from the module. (Figure 4-2 illustrates the signal timing details for powering off the module.)

3.6.4 Secure Boot / Secure Debug

Semtech RC76xx modules incorporate the following permanently enabled features to enhance device security:

Secure Boot—Ensures only firmware images signed by Semtech can be loaded and run on the RC76xx modules. Specifically, Secure Boot applies to the following firmware components: system boot loader, carrier configuration, and telecom FW.

Secure Debug—Disables debug features such as RAM dump collection and JTAG access to the module.

For additional details, refer to application notes available on: <http://source.sierrawireless.com>

3.7 Mechanical Drawing

The Semtech RC76xx module’s LGA footprint is a 239-pad array of copper pads (see [Physical Dimensions and Connection Interface](#)). The following drawing illustrates the device footprint and dimensions.

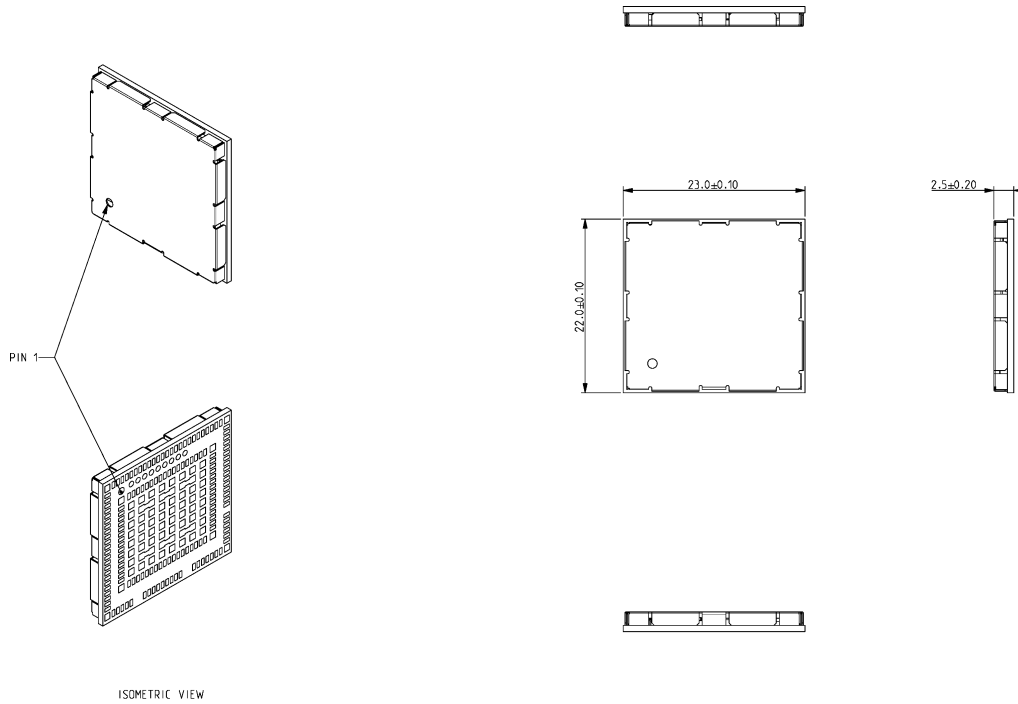

Figure 3-8: Mechanical Drawing 1

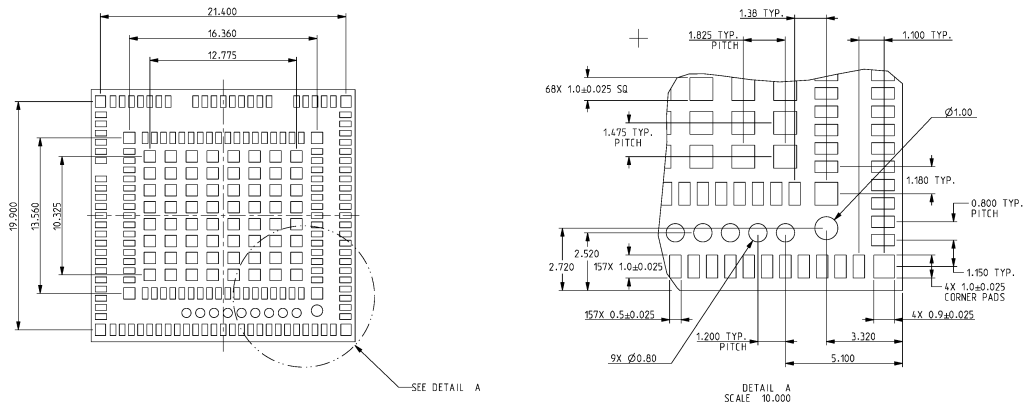

Figure 3-9: Mechanical Drawing 2

3.8 Mechanical Specifications

The following table describes additional mechanical specifications for the Semtech RC76xx module.

Table 3-42: Mechanical Specifications

Specification	Value	Notes
Clamping force	20 psi	Maximum clamping force on module over entire shield surface.

4: Interfaces Specifications

This section describes the interfaces supported by the Semtech RC76xx embedded module and provides specific voltage, timing, and circuit recommendations for each interface.

4.1 POWER_ON_N

The Semtech RC76xx module requires a low level signal (POWER_ON_N) that is used to switch the module ON or OFF.

The POWER_ON_N signal is internally pulled-up which signal level about 0.8V. An open collector or open drain transistor or equivalent should be used to ground the signal when necessary to power on the module. To avoid any damage or abnormal power on signal, do not design any external pull up circuit on this pin.

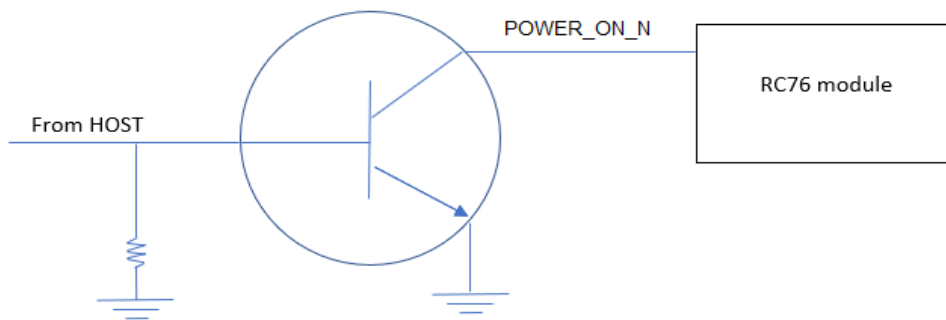

Figure 4-1: POWER_ON_N

To turn the module ON:

Power the module (VBATT on) and connect POWER_ON_N to ground for at least 200 ms and not more than ~7s.

Note: If POWER_ON_N remains connected to the GND for more than ~7s, the module will start and turn off once POWER_ON_N is released.

To turn the module OFF:

Send the AT command, AT!powerdown to turn off module. To avoid any boot issue, turn off the module by pressing the power key or use the AT command to run a graceful shutdown process. While the module is in an active power state mode, asserting POWER_ON_N to low over 1s will turn the module OFF. [Table 4-1](#) describes the POWER_ON_N signal's characteristics.

Table 4-1: POWER_ON_N Electrical Characteristics^a

Parameter	Min	Typ	Max	Units
Input Voltage— Low		-	0.35	V
Internal pull-up resistor	150	200	250	kΩ

a. When floating, voltage will be approximately 800 mV.

4.1.1 Power-up Sequence

4.1.1.1 Power On / Off Timing

The host should not drive any signals to the module until the VGPIO raises up (approximately 100 ms after power ups). Before reaching the “Active” state, signals on the host port must be set to “floating, high impedance, or input pull-down”. This setting also applies when the module is in reset mode, during a firmware update, or during a power-off sequence. The host must consider this signal setting when designing the module interface.

Figure 4-2 describes the timing sequence for powering the module on and off.

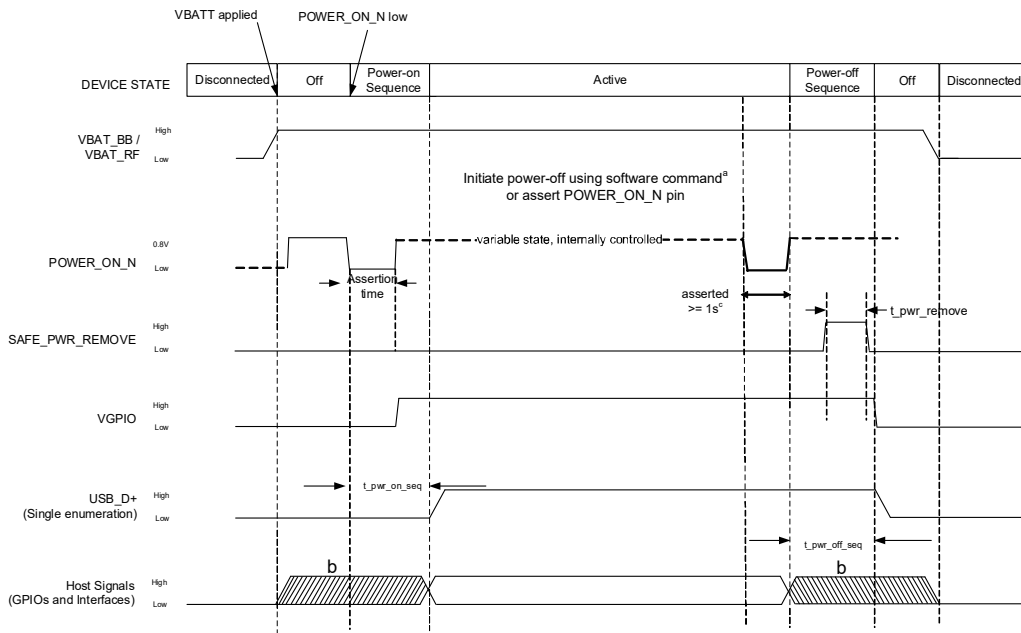

Figure 4-2: Signal Timing (POWER_ON_N, and USB Enumeration)

Notes:

- After the **AT!POWERDOWN** command, the host should ensure that all of the I/O connected to the module are actually either into HighZ, floating, or input pull-down, before the VGPIO switches off.
- When the module is not on active status, the host should ensure that all of the I/O connected to the module are actually either into HighZ, floating, or input pull-down.
- Power-off must be initiated using the POWER_ON_N pin. Initiating power-off via AT commands is not supported.

Table 4-2: POWER_ON_N Timing Parameters

Parameter	Typical	Maximum	Units
t_pwr_on_seq	7	24 ^a	s
t_pwr_off_seq	0.4–5.5	6	s
t_pwr_remove	13	-	ms
POWER_ON_N assertion time ^b	200 ms	7 s	

- a. Value is based on disabled custom parameter "BOOTQUIETDISABLE". Note that there will be an increase in value if this custom parameter is enabled.
- b. Assertion time is the time required to keep POWER_ON_N at LOW level to ensure the module can be powered ON successfully.

4.1.1.2 USB Enumeration

The unit supports single USB enumeration with the host. Enumeration starts within (maximum) t_pwr_on_seq seconds of power-on.

4.1.2 Software-Initiated Power Down

To power down the module via software:

1. Initiate the power down process using **AT!POWERDOWN**.
2. Monitor VGPIO and SAFE_PWR_REMOVE.
3. When VGPIO and SAFE_PWR_REMOVE are on the low level, remove power.

Note:

- If the VGPIO cannot be monitored from the design interface, measure the delay time (pulse from SAFE_PWR_REMOVE to VGPIO must = 0, refer to [Figure 4-33](#) for details) and include this information in the firmware to ensure that power can be removed safely.
- It is highly recommended to run a graceful shutdown using the AT command: **AT!POWERDOWN** to enable powering down rather than cutting off the power directly. This avoids flash/MCP/Memory write-back fail causing flip issues.

4.2 Emergency Power Off

The module can be switched off by controlling the RESET_IN_N pin. This must only be used in emergency situations if the system freezes (not responding to commands).

To perform an emergency power off:

1. De-assert POWER_ON_N.
2. While POWER_ON_N is de-asserted, assert RESET_IN_N (logic low) for at least 8 s. This immediately powers down the module.

4.3 POWER_ON_N, RESET_IN_N, AT!POWERDOWN Use Cases

Table 4-3 lists the behavior of the RC76xx depending on POWER_ON_N, RESET_IN_N and AT!POWERDOWN use cases.

Table 4-3: POWER_ON_N, RESET_IN_N and AT!POWERDOWN Use Cases

Use Case		Behavior
POWER_ON_N	VBATT is applied then POWER_ON_N is asserted	Turns ON
	POWER_ON_N is asserted then VBATT is applied	Turns ON
RESET_IN_N ^a	POWER_ON_N is left asserted then RESET_IN_N is asserted	Resets
	POWER_ON_N is de-asserted then RESET_IN_N is asserted	Resets
	POWER_ON_N is de-asserted then RESET_IN_N is asserted with a long pulse (>8 sec)	Emergency OFF
AT!POWERDOWN ^b	POWER_ON_N is asserted then the power OFF command is sent	Restarts
	POWER_ON_N is de-asserted then the power OFF command is sent	Turns OFF

- a. This pin should only be used for emergencies such as when the module stops responding to AT commands.
- b. It is highly recommended to use graceful shutdown using AT command: AT!POWERDOWN to power down the module rather than cutting the power directly. This prevents flash/MCP/Memory write back fail that results to a flip issue.

4.4 Tx Power Control

The module's Tx power limit may be controlled using the following methods:

- SAR backoff AT commands (see document RC76xx AT Command Reference):
 - **!SARSTATEDFLT** — Set (or report) the default SAR backoff state that the device uses when it powers up. This setting is persistent across power cycles and overrides any PRI setting.
 - **!SARSTATE** — Set (or report) the current SAR backoff state (override the default state). This change in state is non-persistent across power cycles.
 - **!SARBACKOFF** — Set (or report) the maximum Tx power limit for a specific band / technology / state combination.
- GPIO control via **!SARGPIO** command (see RC76xx AT Command Reference)—Set an unallocated external GPIO to control SAR.

4.5 USB

The Semtech RC76xx implements a high-speed USB 2.0 Interface, which conforms to *Universal Serial Bus Specification, Revision 2.0*.

Note: It is recommended to make the USB interface accessible through test points.

Table 4-4: USB Pin Descriptions

Pin	Signal Name	Direction	Function
12	USB_D-	Input/Output	Differential data interface negative
13	USB_D+	Input/Output	Differential data interface positive
16	USB_VBUS	Input	USB supply voltage

Table 4-5: USB_VBUS Characteristic

USB		Value	Units
USB_VBUS	Voltage range	4.75 - 5.25 or VBAT_BB	V
	Maximum Current Drawn	1	mA
	Maximum Input Capacitance (Min ESR = 50 mΩ)	10	μF

Note: The USB interface has routing constraints. For details, refer to [USB Interface](#).

4.6 UART

The Semtech RC76xx provides two UART interfaces:

- UART1 (primary UART) — 8-wire interface
- UART2 (secondary UART) — 4-wire interface (only for internal Semtech debug)

The UART interfaces are used for data communication between the module and a PC or host processor. These interfaces comply with the RS-232 interface.

- UART1 support baud rate: 2400 bps, 4800 bps, 19200 bps, 38400 bps, 57600 bps, 115200 bps, 230400 bps, 921600 bps, 4 Mbps
- UART2 support baud rate: 115200 bps

Flow control is managed using the UART_RTS and UART_CTS signals.

[Table 4-6](#) describes the signals used for UART1 and UART2.

Note:

- UART signals are named with respect to the host device, and directions are listed with respect to the module. For example, UART1_RX is an output from the module to the host. WIFI coex and 8-wire UART concurrency is not supported.
- If there is no pull up setting on host side, or to avoid any unclear signal level when host side is in low power mode, it is recommended to reserve a pull up resistor design on UART_RX and UART_TX pins. The typical resistor value is 100kΩ. This value depends on application and used hardware. For further information, contact a Semtech FAE.

Table 4-6: UART Pins

Pin	Interface	Name ^a	Direction ^b	Function	Reset State	If Unused	Notes
2	UART1	UART1_RI ^c	Output	Ring Indicator Signal incoming calls (voice and data), SMS, etc.	Pull Down	Leave open	Do not install external pull-up on this pin, otherwise the module will not boot.
3		UART1_RTS ^d	Input	Ready To Send, Flow Control	Pull Down		Highly Recommended
4		UART1_CTS ^d	Output	Clear To Send, Flow Control	Pull Down		Highly Recommended
5		UART1_TX ^d	Input	Transmit Data	Pull Down		Highly Recommended
6		UART1_RX ^d	Output	Receive Data	Pull Down		Highly Recommended
7		UART1_DTR ^e	Input (active low)	Data terminal ready Prevents the RC76xx from entering sleep mode, switches between data mode and command mode, and wakes the module.	Pull Down	Leave open	
8		UART1_DCD	Output	Data Carrier Detect Signal data connection in progress	Pull Down	Leave open	Do not install external pull-up on this pin, otherwise the module will not boot.
9		UART1_DSR	Output	Data Set Ready Signal UART interface is ON	Pull Down	Leave open	Do not install external pull-up on this pin, otherwise the module will not boot.
96		UART2 ^{f,d}	UART2_TX	Input	Transmit data	Pull Down	
97	UART2_RX		Output	Receive data	Pull Down		Highly Recommended
98	UART2_RTS		Input	Ready To Send, flow control	Pull Down		Highly Recommended
99	UART2_CTS		Output	Clear To Send, flow control	Pull Down		Highly Recommended

a. Signals are named with respect to the host device. For example, UART1_RX is the signal used by the host to receive data from the module.

- b. Signal direction with respect to the module. For example, UART1_RX is an output from the module to the host.
- c. RI can be used independently and supports the following AT commands: AT+WWAKESET and AT+WRID.
- d. Must be accessible through 0 ohm resistors. Test points are highly recommended at module side.
- e. Pin is 'wakeable'. Can be used to trigger the module to wake up from sleep state. See [Wakeup Interrupt \(Sleep State\)](#) for details. The pin will be floating when KSLEEP=0 and will be pull-up when KSLEEP=1 or 2. For details on KSLEEP, see the RC76xx AT Command Guide.
- f. For Semtech debug purposes.

4.7 UIM Interface

The Semtech RC76xx has two physical UIM interfaces:

- UIM1 — this interface allows control of 1.8V or 2.85V UIMs. For RC7611, RC7611-1, RC7611D, RC7611D-1, RC7612, RC7612-1, RC7620, RC7620-1, RC7630, RC7630-1, and RC7630J* it also supports single or external dual SIMs. For usage details, see [Figure 4-3](#) and [Figure 4-4](#).
- UIM2 — this interface is used to control the following:
 - For RC7611, RC7611-1, RC7611D, RC7611D-1, RC7620, RC7620-1, RC7630, RC7630-1, RC7630J*: this interface is used to control an eSIM on selected variants.
 - For RC7612 and RC7612-1 (Limited Availability): this interface allows control of 1.8V or 2.85V UIMs.

Note:

- * Limited availability.
- UIM1 and UIM2 cannot be activated simultaneously (DSSS). External UIM1 Interface.
- UIM interface is compliant with ETSI TS 102 221 V12.0.0 (2014-12) Class B and Class C.

4.7.1 External UIM1 Interface

The following table describes the signals used for UIM1.

Table 4-7: UIM1 Interface Pins

Pin	Name	Direction ^a	Function	If Unused
26	UIM1_VCC	Output	Supply output	Leave open
27	UIM1_CLK	Output	Clock	Leave open
28	UIM1_DATA	Input/Output	Data connection	Leave open
29	UIM1_RESET_N	Output	Reset	Leave open
64	UIM1_SIMA_DET ^b	Input	Detect UIM	Leave open
65	UIM1_SIMB_DET/GPIO4	Input	Detect UIMB	Leave open
	UIM2_DET ^c /GPIO4		Detect UIM2	
46	Ext_SIM_switch/GPIO6	Output	Switch between UIMA and UIMB	Leave open

- a. Signal direction with respect to the module. Examples: UIM1_SIMA_DET (pin 64) is an input to the module from the host; UIM1_RESET_N (pin 29) is an output from the module to the host.
- b. Pin is 'wakeable'. Can be used to trigger the module to wake up from sleep mode. See [Wakeup Interrupt \(Sleep State\)](#) for details.
- c. Limited Availability for RC7612, RC7612-1.

The UIM2 interface is included with RC7612 and RC7612-1. (Limited Availability).

Table 4-8: External UIM2 Interface

Pin	Name	Direction ^a	Function	If Unused
55	UIM2_VCC	Output	Supply output	Leave open
56	UIM2_DATA	Input/Output	Data connection	
57	UIM2_RESET_N	Output	Reset	
58	UIM2_CLK	Output	Clock	
65	UIM1_SIMB_DET/GPIO4	Input	Detect UIMB	
	UIM2_DET ^{b,c} /GPIO4		Detect UIM2	

- a. Signal direction with respect to the module. Examples: UIM1_SIMA_DET (pin 64) is an input to the module from the host; UIM1_RESET_N (pin 29) is an output from the module to the host.
- b. Pin is 'wakeable'. Can be used to trigger the module to wake up from sleep mode. See [Wakeup Interrupt \(Sleep State\)](#) for details.
- c. Limited Availability for RC7612, RC7612-1 only.

4.7.2 eSIM / UIM2 Interface

4.7.2.1 For RC7611, RC7611-1, RC7611D, RC7611D-1, RC7620, RC7620-1, RC7630, RC7630-1, and RC7630J*

For RC7611, RC7611D, RC7620, RC7630, and RC7630J*, whether an embedded eSIM is provided or not, UIM2 signals are not available externally.

Selection of active SIM between UIM1 (external SIM) and UIM2 (eSIM) is possible using AT commands AT!UIMS and AT!CUSTOM="UIMAUTOSWITCH". Refer to document [1] AirPrime RC76xx AT Command Reference for more details regarding these commands.

When UIM2 is deselected, the eSIM component is unpowered.

**Limited availability*

4.7.2.2 For RC7612 and RC7612-1*

For RC7612 and RC7612-1, UIM2 is available. Selecting an active SIM between UIM1 (external SIM) and UIM2 (external UIM2) is possible using AT commands. Refer to document [1] AirPrime RC76xx AT Command Reference for more details regarding these commands.

**Limited availability*

4.7.3 External SIM Switch Configuration

Note: for RC7611, RC7611D, RC7612, RC7620, RC7630, and RC7630J only*

The UIM1 interface can be used with either a single external SIM, or with two external SIMs, using an external switch. The external switch is controlled by GPIO6 (pin 46), and GPIO4 is used to detect the second external SIM.

An external PU should be provided on the UIM1_SIMB_DET.

** Limited availability*

1 external SIM card

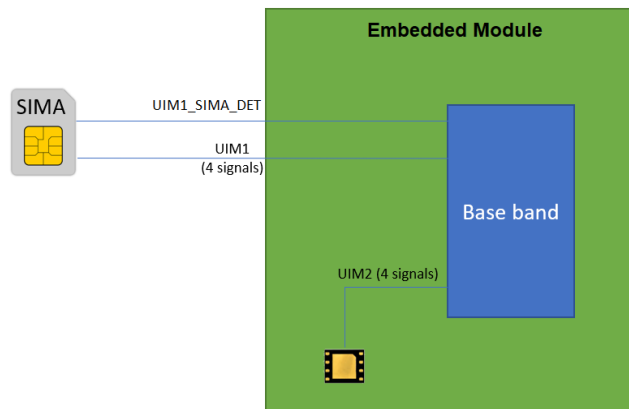

Figure 4-3: Single External SIM Configuration

Note: Figure 4-3 illustrates the recommended implementation of a single external SIM configuration. For a detailed UIM schematic, see Figure 5-8.

2 external SIM cards (with 2 dedicated SIM detects)

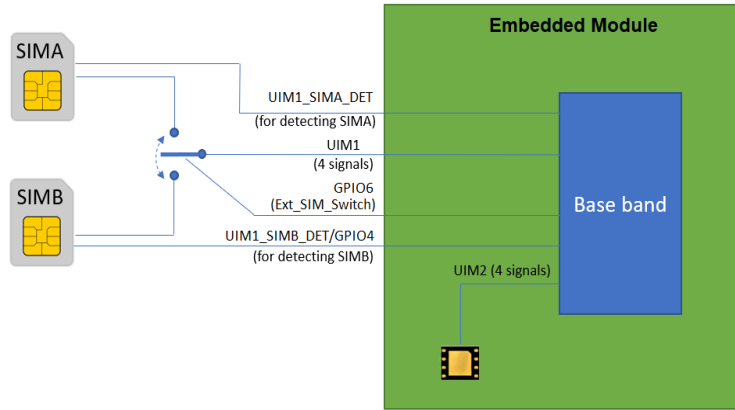

Figure 4-4: Dual External SIM Configuration

Note: [Figure 4-4](#) illustrates the recommended implementation of a dual external SIM configuration. For a detailed external SIM schematic, see [Figure 5-9](#).

Supports two external SIM and signal switching using GPIO6, while SIM B is detected by GPIO4. See [GPIO6](#) and [GPIO4](#) for details.

4.8 General Purpose Input / Output

The Semtech RC76xx defines several GPIOs for customer use, as described in [Table 4-9](#). For electrical specifications, see [Table 3-35](#) and [Table 3-36](#).

Note: There should not be any voltage applied to the GPIOs when the module is off or resetting..

Table 4-9: GPIO Pin Description

Pin	Signal Name	Edge Wakeable	Default State	Function	If Unused
10	GPIO2 ^a	Yes	PD ^b	General purpose I/O	Leave open
40	GPIO7	Yes			
41	GPIO8				
44	GPIO13	Yes			
46	GPIO6 ^c	Yes			
65	GPIO4 ^d				
101	GPIO35	Yes			
104	GPIO32				
105	GPIO33				
109	GPIO42 ^a	Yes			
147	GPIO21 ^a	Yes			
148	GPIO22	Yes			
149	GPIO23				
150	GPIO24	Yes			
153	GPIO28 ^e				
154	GPIO29 ^e				
155	GPIO30 ^e				
156	GPIO31 ^e				
159	GPIO25				

- a. Pin is 'wakeable'. Can be used to trigger the module to wake up from sleep mode. See [Wakeup Interrupt \(Sleep State\)](#) for details.
- b. Internal configuration of all GPIOs—internal input pull-down.
- c. See [GPIO6](#).
- d. See [GPIO4](#).
- e. This pin is available for use when configured using **AT+WIOCFG**.

4.9 GPIO4

GPIO4 can be used for two different functions as described below.

4.9.1 SIM Detect

GPIO4 can provide a detect function to the external UIM2 to detect the physical presence of a UIM card in the UIM holder. The signal needs an external pull-up resistor on it.

The UIM detect signal transitions:

- When a UIM is inserted—high (logic 0 to logic 1)
- When a UIM is removed—low (logic 1 to logic 0)

To use this pin for SIM detect, enable the feature using:

1. `AT!CUSTOM="EXTUIMSWITCHEN";1`
2. `AT+KSIMSEL=2`
3. Reboot the module.

4.9.2 General Purpose Input / Output

To configure this pin as a GPIO:

1. Disable external SIM detect feature using `AT!UNLOCK="A710"`.
2. Use `AT+CUSTOM="UIM2ENABLE";0`.
3. Reboot the module.
4. Configure GPIO4 using `AT+WIOCFG=4,4`.
5. The default GPIO state is a digital input pull-down function.

4.10 GPIO6

GPIO6 can be used for three different functions as described below. Refer to the RC76xx AT Command Reference for AT command details to configure GPIO6.

4.10.1 SIM Switching

To use this pin for fast SIM switching, enable the feature using `AT!CUSTOM="EXTUIMSWITCHEN";1`.

4.10.2 General Purpose Input / Output

To configure this pin as a GPIO:

1. Disable external SIM switch feature using `AT!CUSTOM="EXTUIMSWITCHEN";0`.
2. Configure GPIO6 using `AT+WIOCFG=6,4`.
3. Reboot the module.
4. The default GPIO state is a digital input with 10 μ A pull-down function.

4.10.3 RESET_OUT_N

This pin can be used to provide a signal that will hold peripheral devices (such as a USB hub, I²C device, etc.) in reset until the power-up sequence is complete.

To configure this pin as Reset:

1. Disable external SIM switch feature using **AT!CUSTOM="EXTUIMSWITCHEN" , 0**.
2. Configure GPIO6 using **AT+WIOCFG=6 , 0**.

Note: For details, refer to the Semtech RC76xx AT Command Reference guide.

3. Reboot the module.

When the module is:

- In reset or powering up—this pin is held low to put peripheral devices in reset. Once the power-on sequence is complete, this pin will be turned high to take the peripherals out from reset.
- In PSM—this pin will keep its previous status.

For timing details between RESET_IN_N and RESET_OUT_N, see [Reset Signals \(RESET_IN_N and RESET_OUT_N\)](#).

4.11 Wakeup Interrupt (Sleep State)

The following pins can be used to wake the device when it is in Sleep state:

- GPIO2
- GPIO21
- GPIO42
- UART1_DTR
- UIM1_SIMA_DET
- UIM1_SIMB_DET

The GPIO pins can be configured as a wakeup source by using the AT+WIOCFG command (see RC76xx AT Command Reference).

If the device firmware is monitoring these pins while the device is in sleep mode, any transition on these pins will wake the device.

Note: These signals wake the device when it is in Sleep state. If the device is in PSM, it is woken by configured wakeup triggers—see [Wakeup Events \(PSM\)](#) for details.

4.12 Wakeup Events (PSM)

The following signals/sources can be used to wake the device from PSM:

Table 4-10: PSM Wakeup Signals/Sources

Signal Configuration	Signal
Configurable	Timer
Always enabled	POWER_ON_N
Always enable	RESET_IN_N

Note: These signals wake the device only when it is in PSM. If the device is in Sleep state, it can be woken using the signals described in [Wakeup Interrupt \(Sleep State\)](#).

For PSM details, see [Table 3-5](#).

4.13 I²C Interface

The Semtech RC76xx module provides one I²C (Inter-Integrated Circuit) dedicated serial port (bus interface) based on I2C Bus Specification, Version 5.0, October 2012.

The interface uses the pins indicated in [Table 4-11](#).

Table 4-11: I²C Interface Pins

Pin	Signal Name	Direction	Function	If Unused	Reset State
1	I2C1_CLK	Input/Output	I ² C Clock	Leave open	Internal pull-down
66	I2C1_DATA	Input/Output	I ² C Data	Leave open	Internal pull-down

This implementation of the I²C interface includes the following characteristics:

- Supported voltage — 1.8 V
- Standard-mode interface — data transfer rates up to 100 kbit/s
- Master mode operation only — the module always operates as the master
- I²C signals are implemented internally as open drain outputs (per the I²C specification) with 2.2 kΩ pull-up resistors to VGPI0 (see [Figure 4-5](#)).

Note: I²C slave address 0x1A is reserved for internal use.

For I²C bus details, including I2C bus waveform and timing details, refer to the I2C Bus Specification.

4.13.1 Application

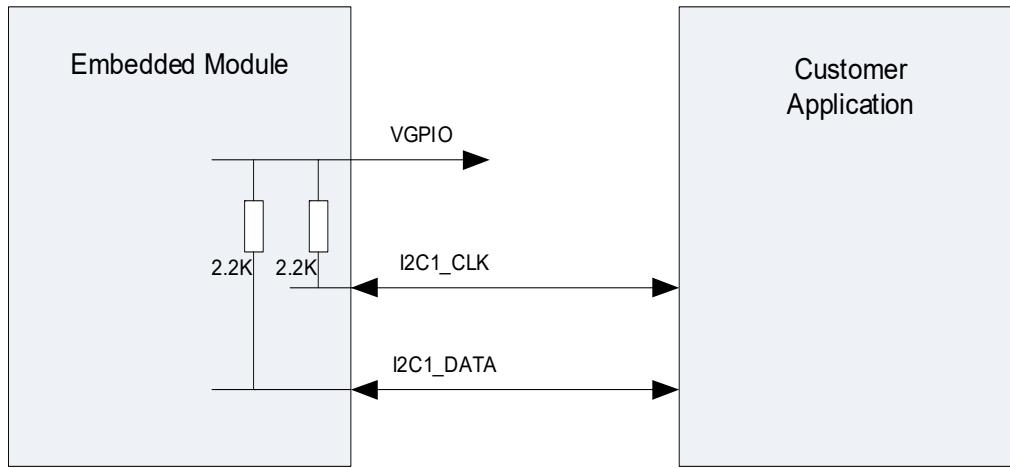

Figure 4-5: Example of I²C Bus Application

4.14 VGPIO

The Semtech RC76xx utilizes 1.8V logic, provided via the VGPIO (GPIO voltage output) pin.

Table 4-12: VGPIO Reference Pin

Pin	Signal Name	Direction ^a	Function	If Unused
45	VGPIO	Output	GPIO voltage output	Leave open

a. Signal direction with respect to the module — VGPIO (pin 45) is an output from the module to the host.

Table 4-13: VGPIO Electrical Characteristics

Parameter	Min	Typ	Max	Unit	Remarks
Voltage level	1.7	1.8	1.9	V	Applies to active mode and sleep mode
Current capability	-	-	50	mA	Power Management support up to 50 mA output

The VGPIO voltage is available when the module is switched ON, and can be used to:

- Pull up signals such as I/Os
- Supply external digital transistors driving LEDs
- Act as a voltage reference for the ADC interfaces
- Supply external circuitry. Make sure you do not exceed the maximum current capability. Use an external regulator if a higher consumption is required.

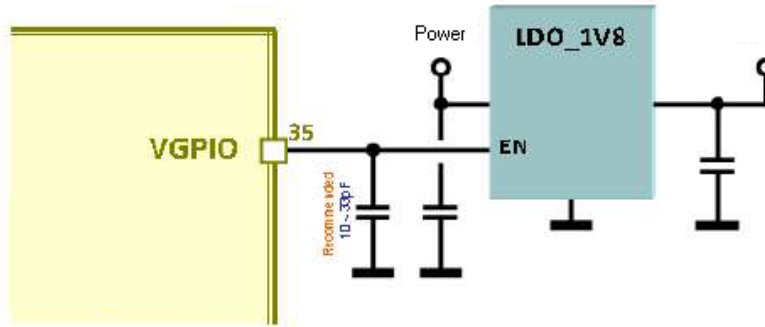

Note: VGPIO is at a high level (1.8V) when the module is in active or sleep mode. VGPIO is off (high impedance), when the module is in PSM or in off mode. Signal referenced to VGPIO are as follows (signals power group is VGPIO):

- Internal pull down (FW setting) signals:
overshoot voltage: 50mV,
- No-pull signals:
overshoot voltage: 50 mV,
- Internal pull up (FW setting) signals:
Same situation with VGPIO

4.15 Reset Signals (RESET_IN_N and RESET_OUT_N)

The Semtech RC76xx provides an interface to allow an external application to reset the module (RESET_IN_N) and reset the peripheral device (RESET_OUT_N).

Note: Using RESET_IN_N to reset the module could result in memory corruption if used inappropriately. This signal should only be used if the module has become unresponsive and it is not possible to perform a power cycle. Adding a test point is recommended.

Table 4-14: RESET Pins

Pin	Signal Name	Direction ^a	Function	If Unused
11	RESET_IN_N	Input	External Reset Input	Leave open
46 (GPIO6)	RESET_OUT_N	Output	Peripheral devices reset	Leave open

a. Signal direction with respect to the module—RESET_IN_N (pin 11) is an input to the module from the host.

The RESET_IN_N signal is internally pulled-up with 40kΩ. An open collector or open drain transistor or equivalent should be used to ground the signal, when necessary, to reset the module. To avoid any damage or abnormal reset signal, do not design any external pull up circuit on this pin.

To avoid any damage or abnormal reset signal, please do not design any external pull up circuit on this pin.

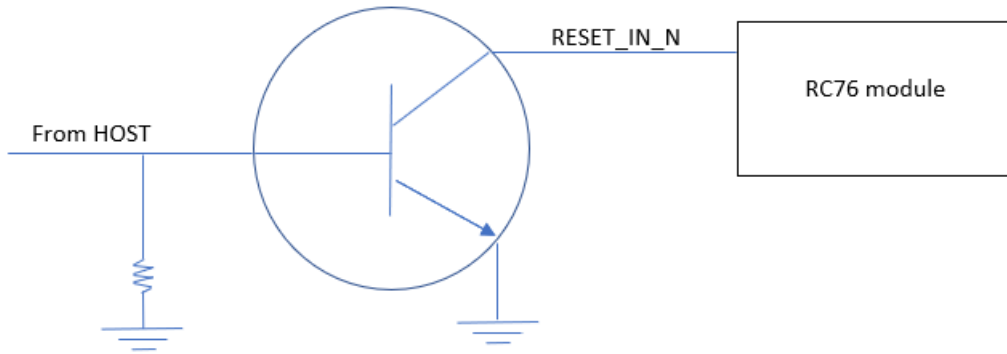

Figure 4-6: RESET_IN_N

To reset the module, a low level pulse must be applied on the RESET_IN_N pin. This will immediately restart the module.

The RESET_IN_N signal will reset the registers of the CPU and reset the RAM memory as well, for the next power on.

Table 4-15: Reset Timing

Symbol	Parameter	Min	Typ	Max
Trdet	Duration of RESET_IN_N signal before firmware detects it (debounce timer)	-	32 ms	-
Trlen1	Duration RESET_IN_N asserted	42 ms	-	-
Trlen2	Duration RESET_OUT_N asserted	420 ms	-	-
Trdel1	Delay between minimum Reset duration and internal reset generated	18 ms	-	-
Tduration	Duration time from RESET_IN_N falling edge to RESET_OUT_N	50 ms	-	-

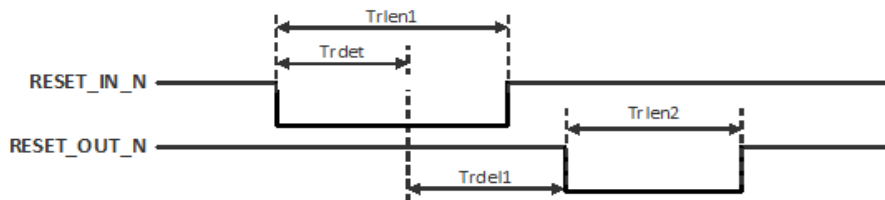

Figure 4-7: Reset timing when RESET_IN_N < Trdel1

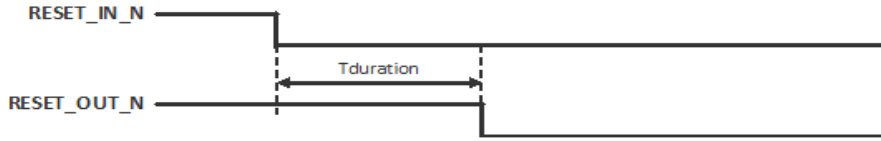

Figure 4-8: Reset timing when RESET_IN_N is held low

4.16 ADC

The Semtech RC76xx provides two general purpose ADC (Analog to Digital Converter) inputs, as described [Table 4-16](#) and [Table 4-17](#).

Table 4-16: ADC Interface Pins

Pin	Signal Name	Direction ^a	Function	If Unused
24	ADC1	Input	Analog to Digital Converter	Leave open or Ground
25	ADC0	Input	Analog to Digital Converter	Leave open or Ground

a. Signal direction with respect to the module. Example: ADC1 (pin 24) is an input to the module from the host.

Table 4-17: ADC Interface Characteristics

Parameter	Value	Units
Full-scale voltage level	0.1–1.7	V
Resolution	15	bit
Sample rate	2.4	MHz
Voltage error	8 (Typ), 16 (Max)	mV

4.17 Digital Audio

The Semtech RC76xx provides a 4-wire digital audio interface that can be configured as either PCM (Pulse Code Modulation) or I²S (Inter-IC Sound).

[Table 4-18](#) describes the audio interface signals.

Note: Audio availability is firmware-dependent.

Table 4-18: PCM / I²S Interface Signals

Pin	Signal name	Direction ^a	Function	Reset State	If Unused
33	PCM_OUT	Output	PCM Data Out The frame "data out" relies on the selected configuration mode.	Pull Down	Leave open
	I2S_OUT	Output	I2S Data Out The frame "data out" relies on the selected configuration mode.	Pull Down	
34	PCM_IN	Input	PCM Data In The frame "data in" relies on the selected configuration mode.	Pull Down	Leave open
	I2S_IN	Input	I2S Data In The frame "data in" relies on the selected configuration mode.	Pull Down	
35	PCM_SYNC	Input/Output in Primary mode	PCM Sync The frame synchronization signal delivers an 16 kHz frequency pulse that synchronizes the frame data in and the frame data out.	Pull Down	Leave open
	I2S_WS	Output	I2S Word Select The word select clock indicates which channel is currently being transmitted (low cycle indicates left audio channel, high cycle indicates right audio channel).	Pull Down	
36	PCM_CLK	Input/Output in Primary mode	PCM Clock The frame bit clock signal controls data transfer with the audio peripheral.	Pull High	Leave open
	I2S_CLK	Output	I2S Clock The frame bit clock signal controls data transfer with the audio peripheral.	Pull High	

a. Signal direction with respect to the module. Examples: PCM_IN (pin 34) is an input to the module from the host; PCM_OUT (pin 33) is an output from the module to the host.

4.17.1 PCM

Table 4-19 defines the PCM interface configuration. Data Format

Table 4-19: PCM Interface Configurations

Element	PCM
Slot configuration	Slot-based
Sync type	Long

Table 4-19: PCM Interface Configurations (Continued)

Element	PCM
Clock (Master)	512 KHz
Data formats	16-bit linear
Mode	Master

4.17.1.1 Data Format

The PCM data is 16 kHz and 16 bits with the following PDM (Pulse-density modulation) bit format:

- PCM_DIN — SDDD DDDD DDDD DDVV
- PCM_DOUT — SDDD DDDD DDDD DDVV

Where:

- S — Signed bit
- D — Data
- V — Volume padding

4.17.1.2 Timing

The following table and drawings illustrate PCM signals timing when operating in PCM mode.

Table 4-20: PCM Mode Timing^a

Parameter	Description	Min	Typ	Max	Units
t(auxsync)	PCM_SYNC cycle time	-	62.5	-	us
t(auxsynca)	PCM_SYNC high time	-	31.2	-	us
t(auxsyncd)	PCM_SYNC low time	-	31.2	-	us
frequency(SYNC)	Data formats	-	16	-	kHz
frequency(CLK)	Clock (Master)	-	515	-	kHz
t(auxclk)	PCM_CLK cycle time	-	1.94	-	us
t(auxclkh)	PCM_CLK high time	-	975	-	ns
t(auxclkl)	PCM_CLK low time	-	975	-	ns
t(suauxsync)	PCM_SYNC setup time high before falling edge of PCM_CLK	-	0	-	ns
t(hauxsync)	PCM_SYNC hold time after PCM_CLK rising	-	996	-	ns
t(suauxdin)	PCM_IN setup time before falling edge of PCM_CLK	-	975	-	ns
t(hauxdin)	PCM_IN hold time after falling edge of PCM_CLK	-	994	-	ns
t(pauxdout)	Delay from PCM_CLK rising to PCM_OUT valid	-	0	-	ns

a. Maximum PCM clock rate is 512 kHz.

PC Sync Timings

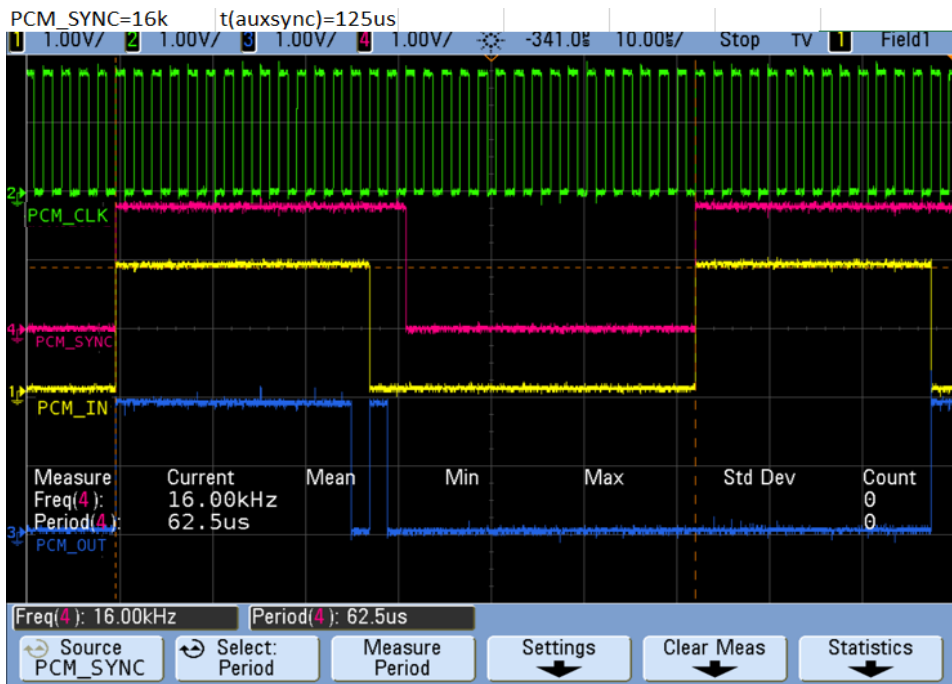

Figure 4-9: t(sync)

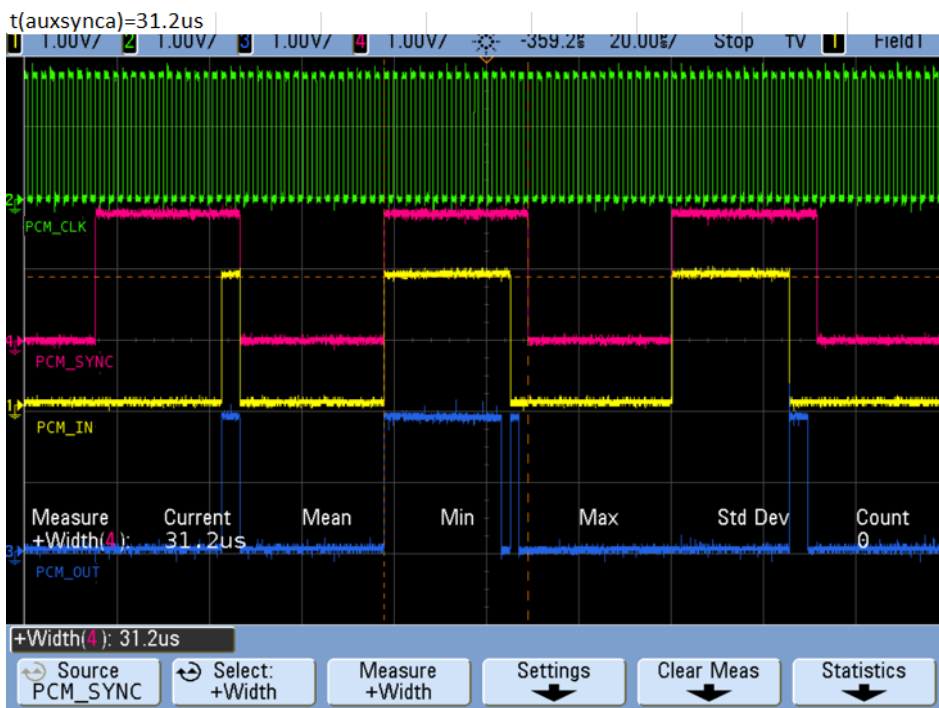

Figure 4-10: t(synch)

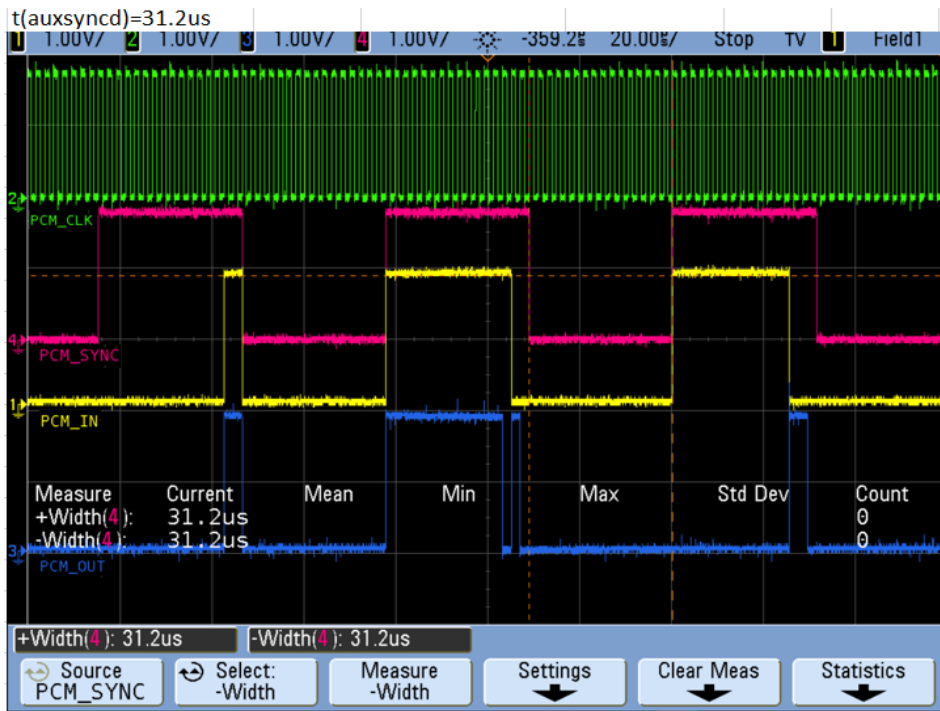

Figure 4-11: $t(\text{syncd})$

PCM Codec to Device Timings

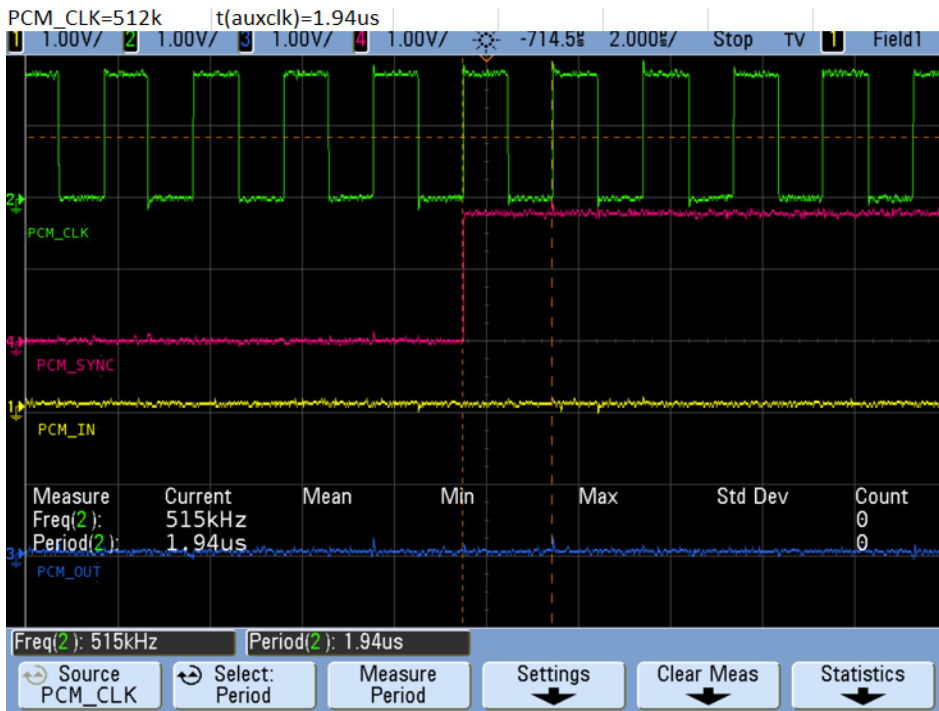

Figure 4-12: t(auxclk)

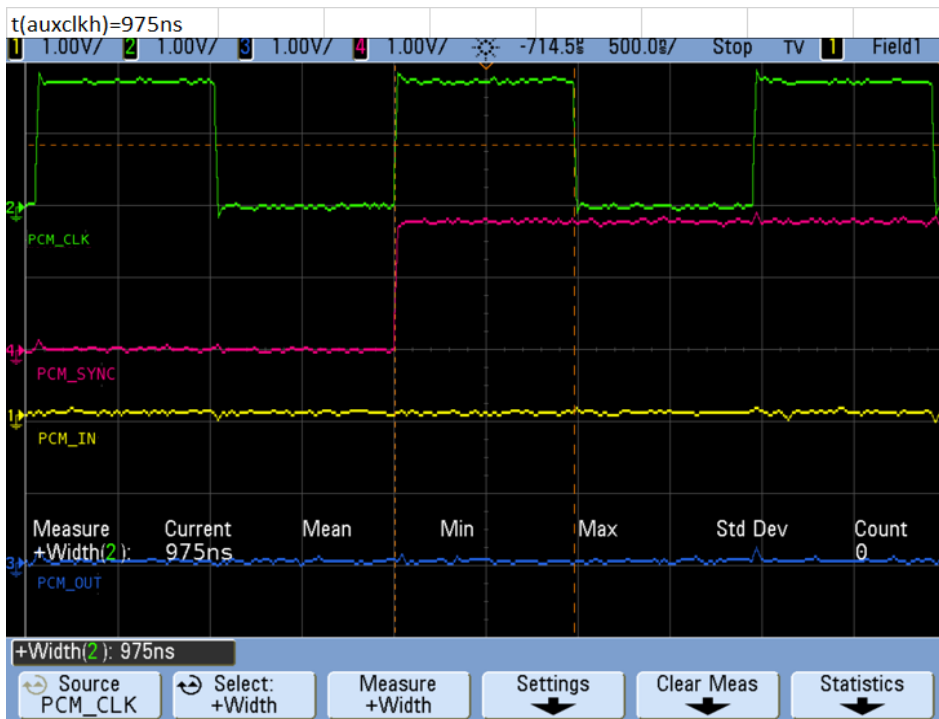

Figure 4-13: t(auxclk)

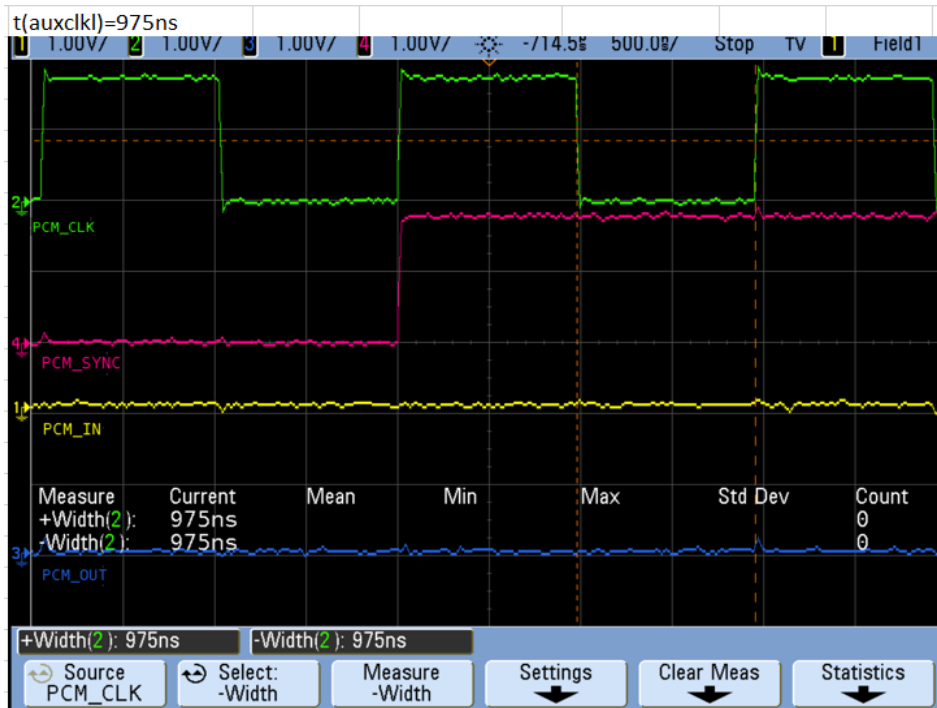

Figure 4-14: t(auxclk)

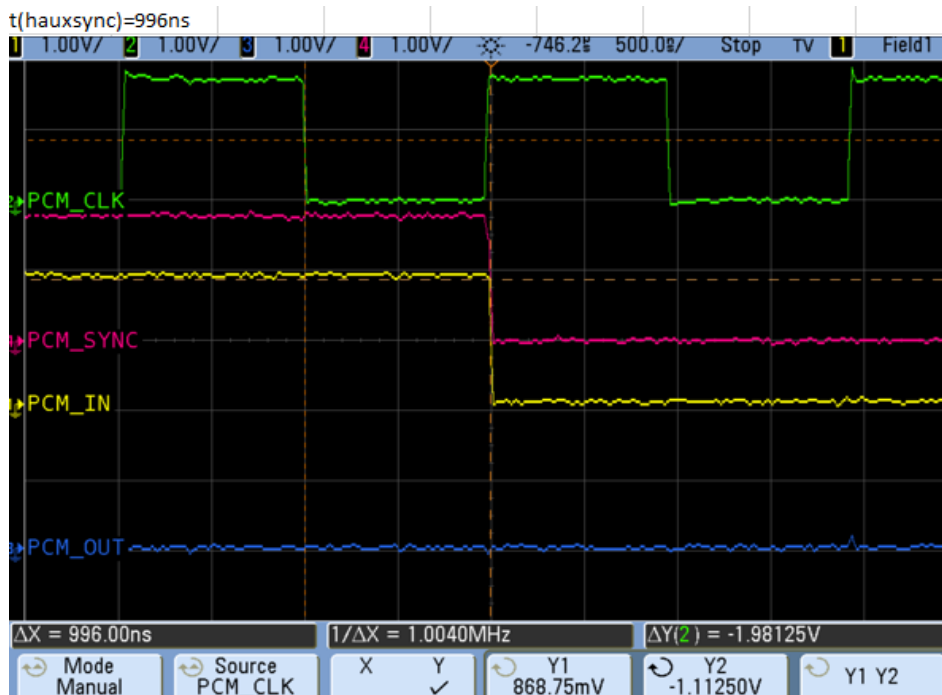

Figure 4-15: t(hauxsync)

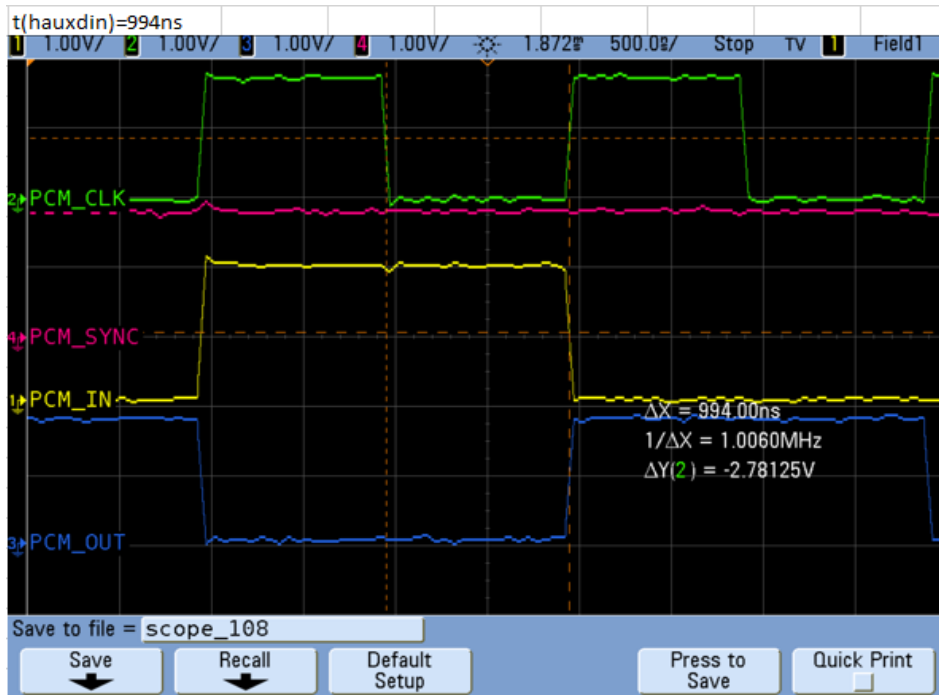

Figure 4-16: $t(\text{hdin})$

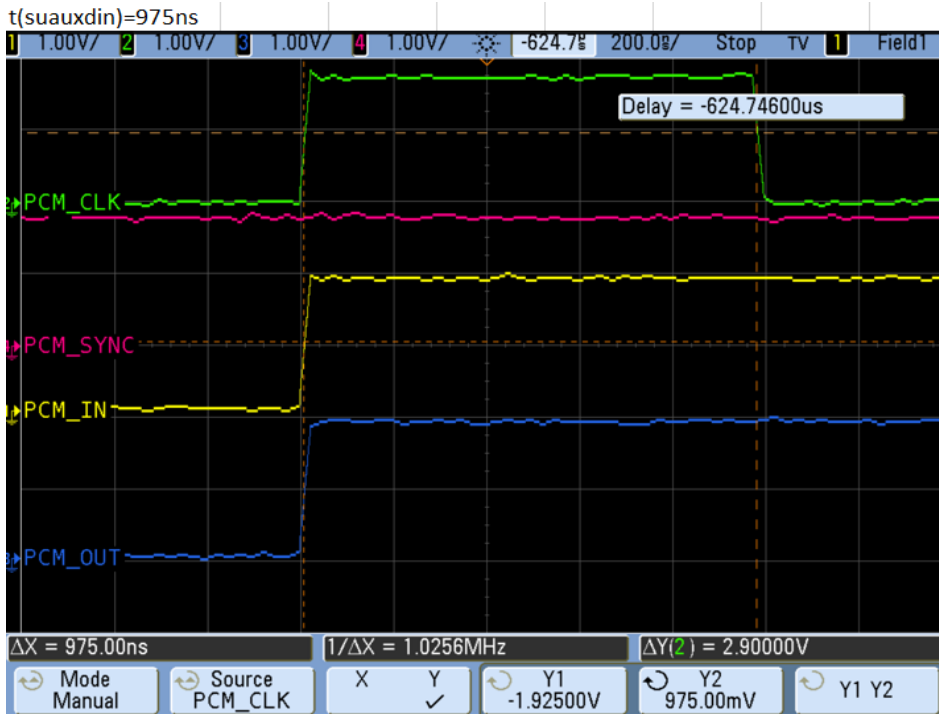

Figure 4-17: $t(\text{sdin})$

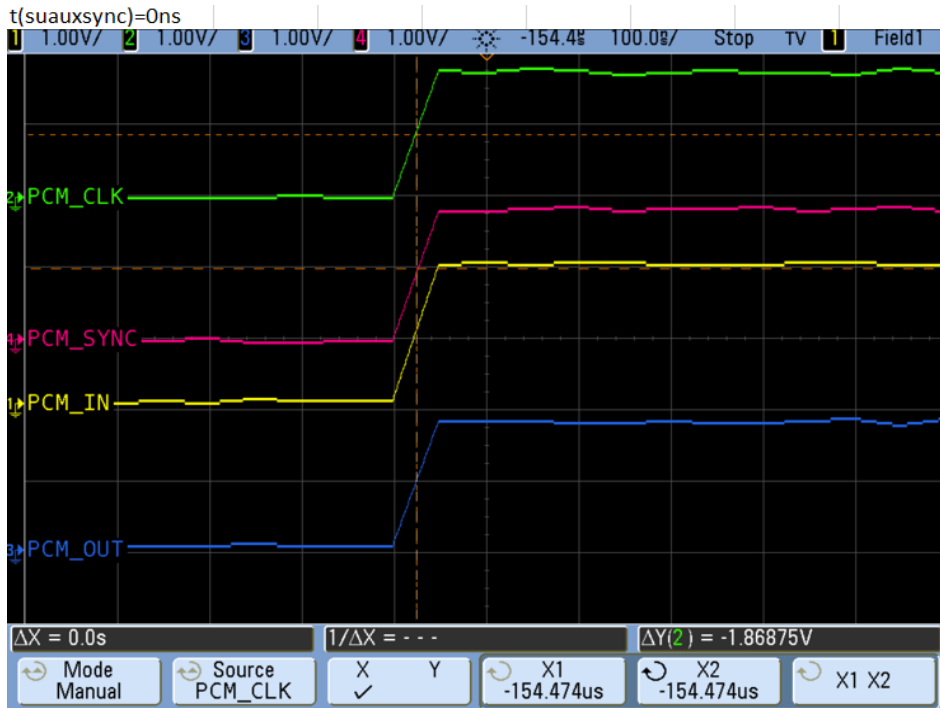

Figure 4-18: $t(susync)$

Device to PCM Codec Timings

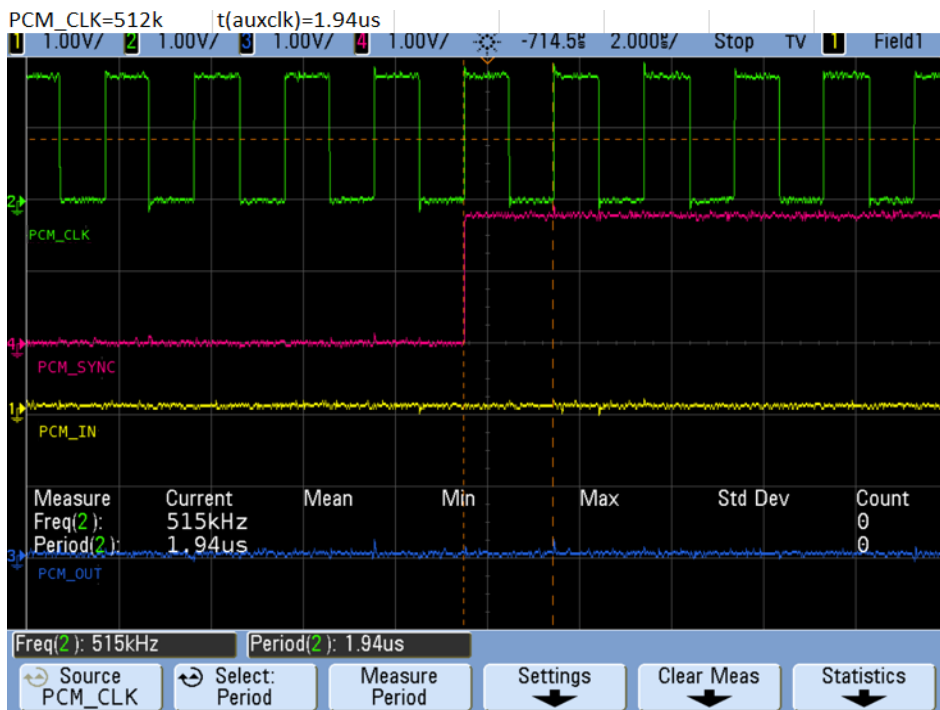

Figure 4-19: $t(clk)$

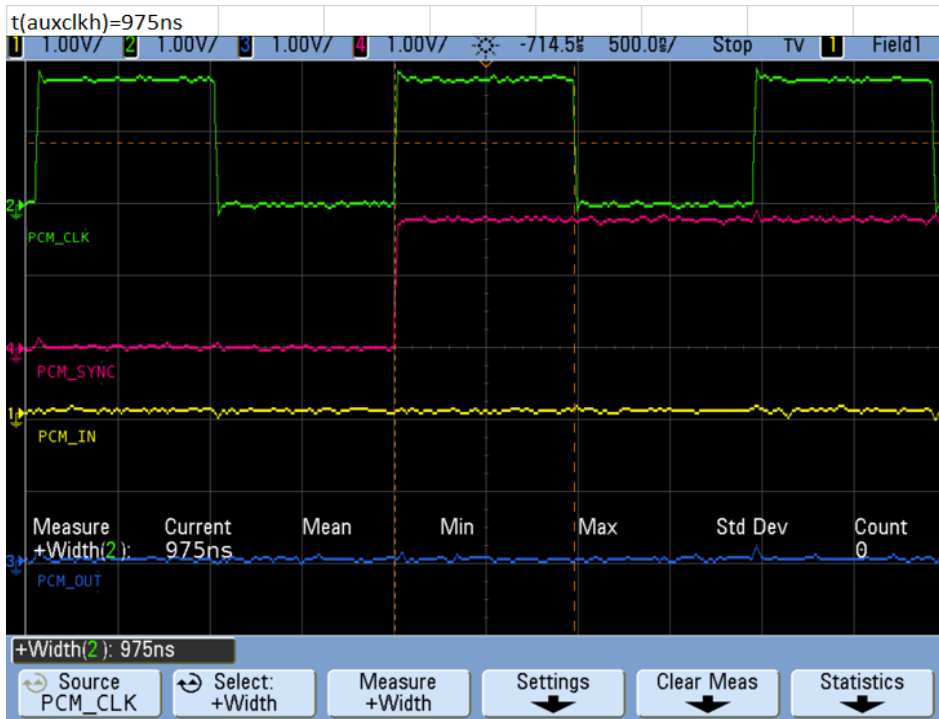

Figure 4-20: $t(\text{clkh})$

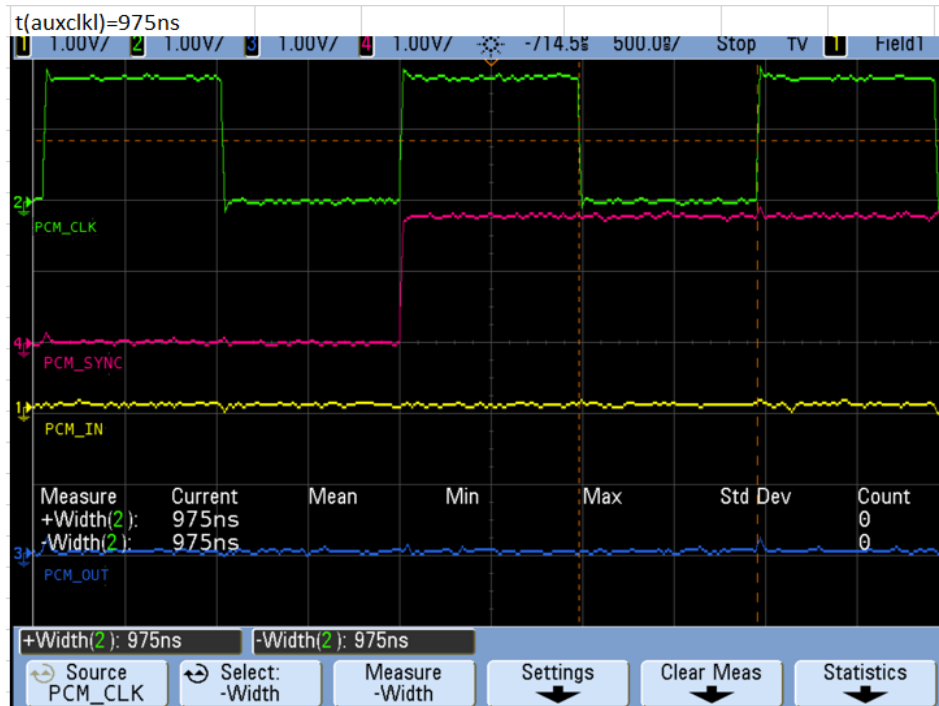

Figure 4-21: $t(\text{ckl})$

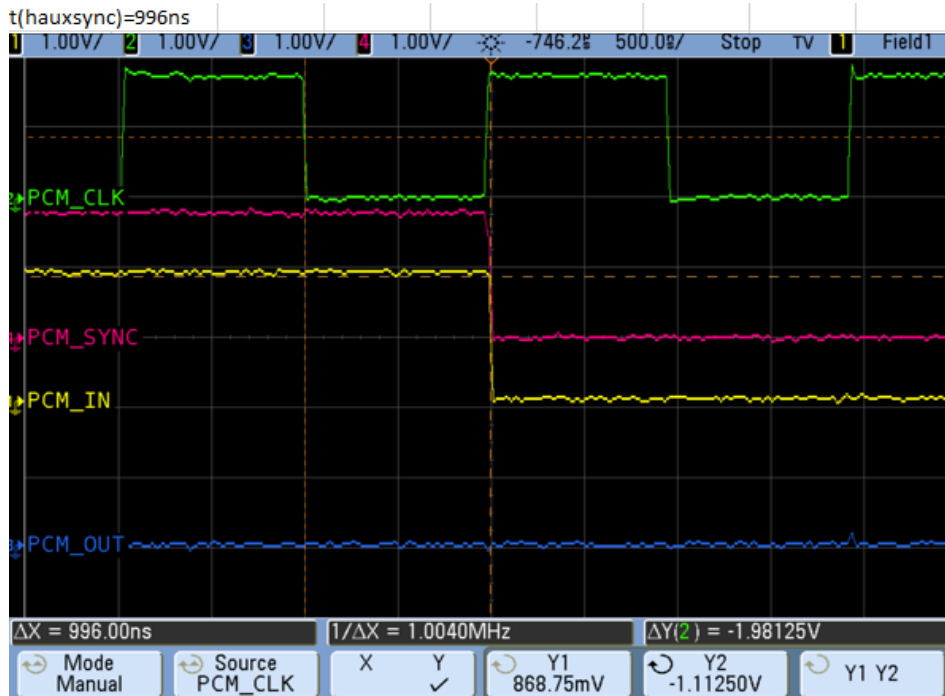

Figure 4-22: $t(\text{hauxsync})$

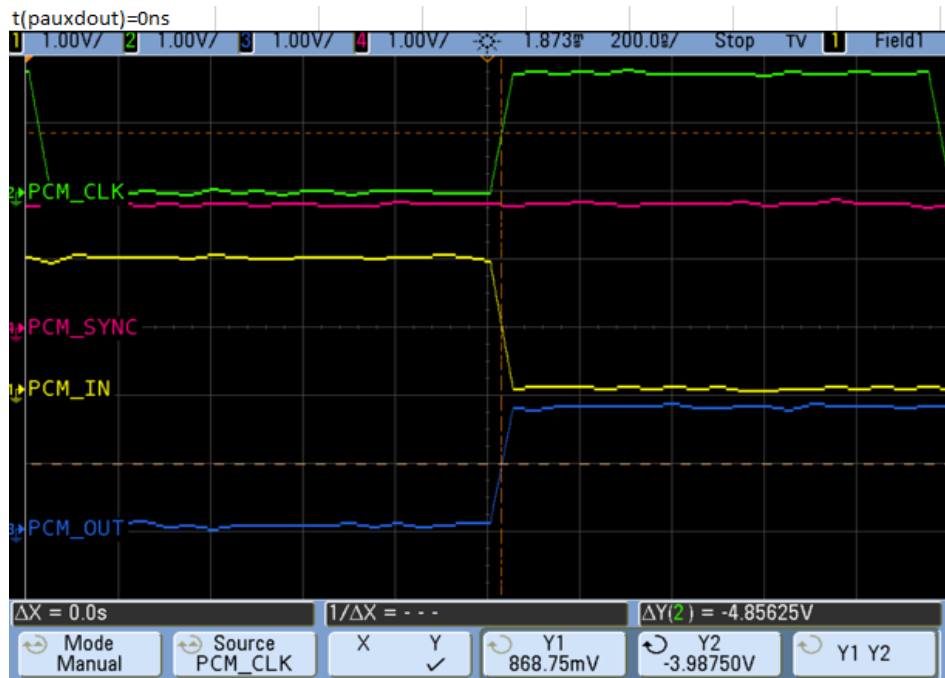

Figure 4-23: $t(\text{pauxdout})$

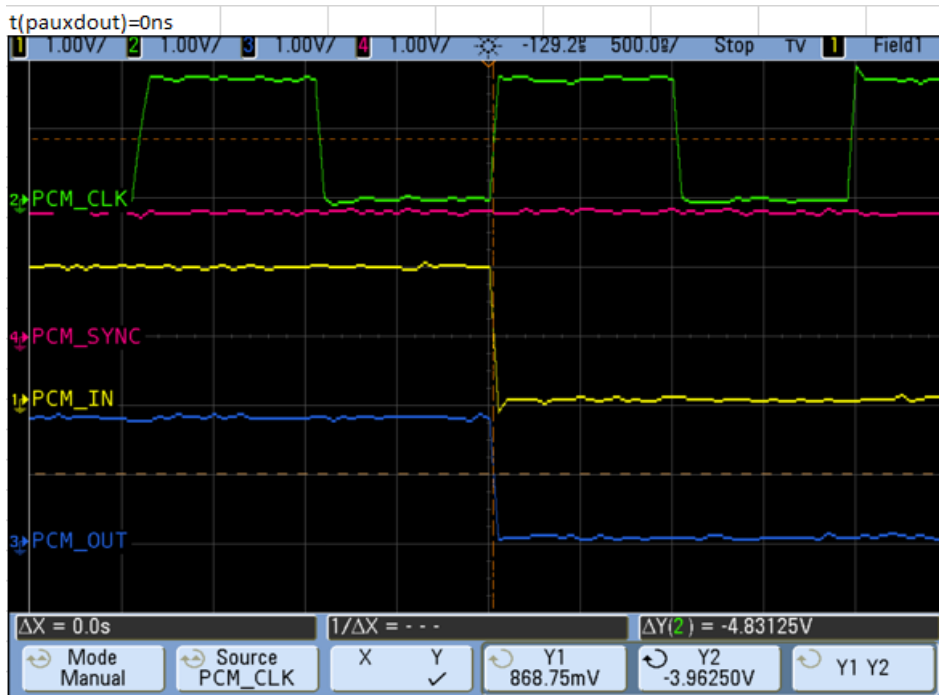

Figure 4-24: t(pauxdout)R

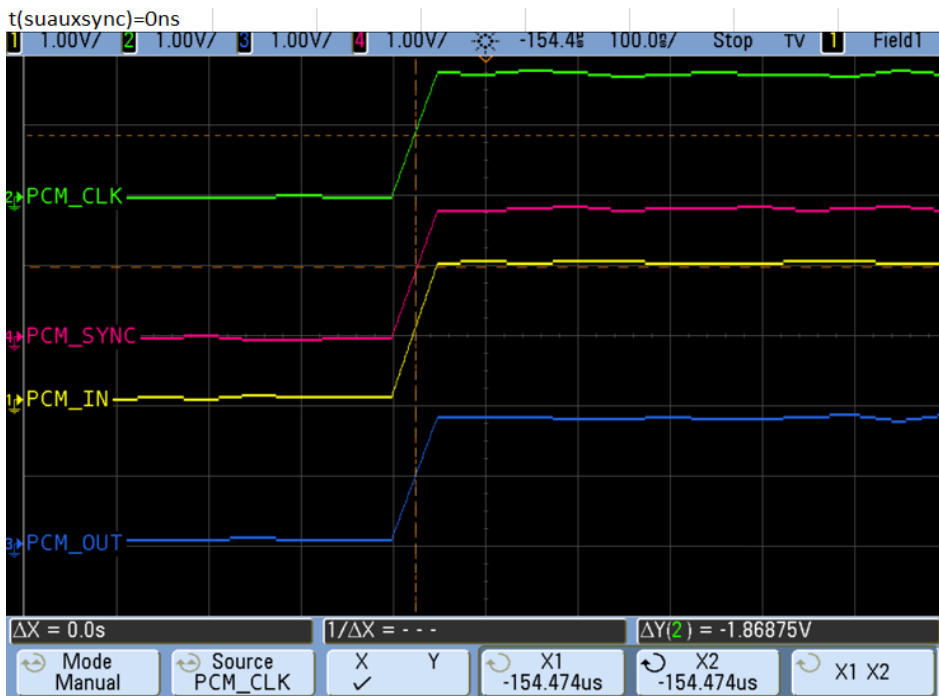

Figure 4-25: t(susync)

4.17.2 I²S

The I²S interface can be used to transfer serial digital audio to or from an external stereo DAC/ADC and supports the following features:

- Mode: Master (Slave mode is not supported)
- Sampling rate: 16 kHz
- Bits per frame: 16
- Bit clock: 512 kHz

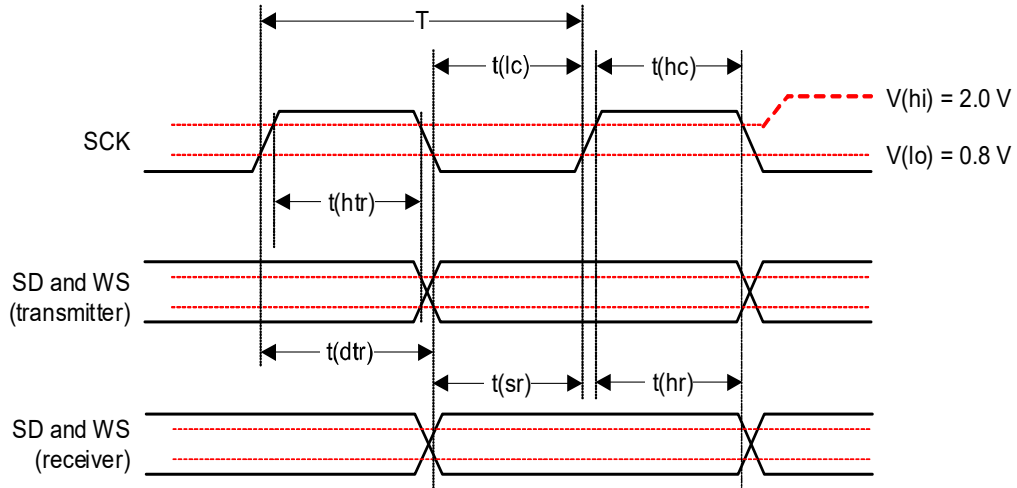

Figure 4-26: I²S Transmitter Timing

Table 4-21: I²S Interface Timing^a

Parameter	Description	Min	Typ	Max	Units
	Frequency	-	-	12.288	MHz
T	Clock period	81.380	-	-	ns
t(hc)	Clock high	0.45 × T	-	0.55 × T	ns
t(lc)	Clock low	0.45 × T	-	0.55 × T	ns
t(sr)	SD and WS input setup time	16.276	-	-	ns
t(hr)	SD and WS input hold time	0	-	-	ns
t(dtr)	SD and WS output delay	-	-	65.100	ns
t(htr)	SD and WS output hold time	0	-	-	ns

a. Load capacitance is 10–40 pF

4.18 SPI Bus

The Semtech RC76xx module provides one 4-wire serial peripheral interfaces (SPI1).

The following features are available on the SPI bus:

- Mode: Master (Slave mode is not supported)
- SPI speed from 960 kbps to 25 Mbps in master mode operation
- 4-wire interface
- 4 to 32 bits data length
- 38 MHz clock frequency

Table 4-22 describes the SPI interface pins.

Table 4-22: SPI Pin Descriptions

Pin	Signal Name	Direction ^a	Description	Reset State	I/O Type
51	SPI1_MRDY	Output	SPI Master Ready	Internal Pull-Down	1V8
52	SPI1_MISO	Input	SPI Master Input / Slave Output (output from slave)		
53	SPI1_CLK	Output	SPI serial clock (output from Master)		
54	SPI1_MOSI	Output	SPI Master Output / Slave Input (output from master)		

- a. Signal direction with respect to module. Examples: SPI1_MISO (pin 52) is an input to the module from the host; SPI1_CLK (pin 53) is an output from the module to the host.

4.18.1 Configuration

Table 4-23: SPI Configuration

Operation	Max Speed	SPI-Mode	Duplex	4-wire Type
Master	25 Mb/s	0,1,2,3	Full	<ul style="list-style-type: none"> ▪ SCLK (SPI1_CLK) ▪ MOSI (SPI1_MOSI) ▪ MISO (SPI1_MISO) ▪ SS (SPI1_MRDY)

4.18.2 Waveforms

The following figure shows waveforms for SPI transfer using a 4-wire configuration.

Figure 4-27: 4-Wire Configuration SPI Transfer

Table 4-24: SPI Master Timing Characteristics (@38 MHz)

Parameter	Min	Typ	Max	Unit
SPI clock frequency	-	-	38	MHz
T ^a	SPI clock period	20.0	-	ns

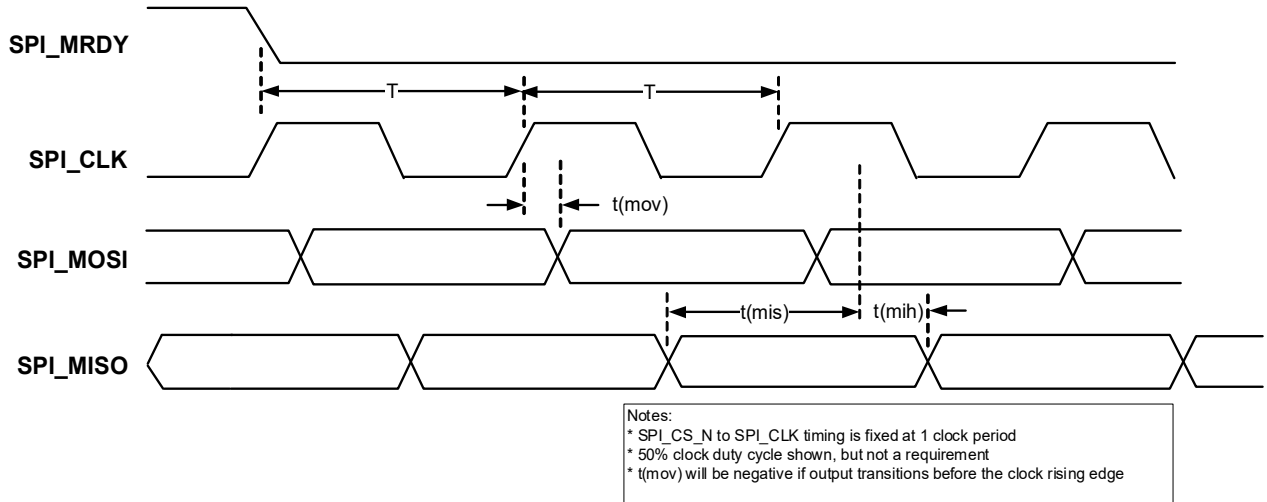

Table 4-24: SPI Master Timing Characteristics (@38 MHz) (Continued)

Parameter		Min	Typ	Max	Unit
t(ch)	Clock high	9.0	-	-	ns
t(cl)	Clock low	9.0	-	-	ns
t(mov)	Master output valid	-5.0	-	-5.0	ns
t(mis)	Master input setup	5.0	-	-	ns
t(mih)	Master input hold	1.0	-	-	ns

a. Minimum clock period includes 1% jitter of the maximum frequency

4.18.3 Application

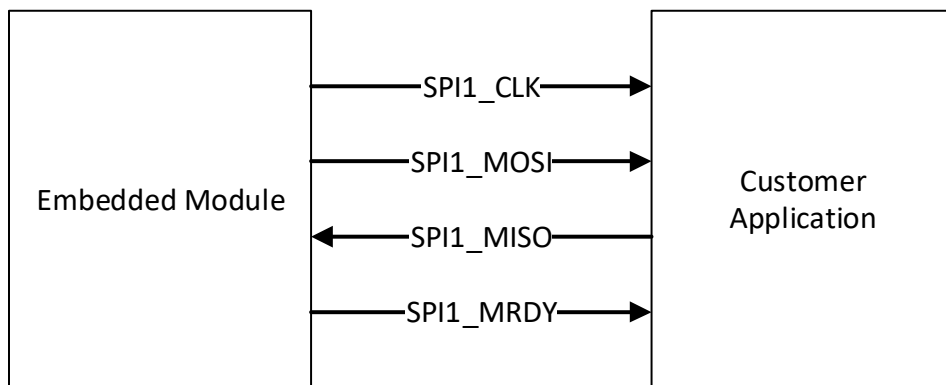

Figure 4-28: Example of 4-wire SPI Bus Application

4.19 Clock

The Semtech RC76xx supports two digital clock interfaces that are connected directly from the PMIC.

Table 4-25 describes the clock interface pins.

Table 4-25: Clock Interface Pin Descriptions

Pin	Signal Name	I/O	I/O Type	Description	If Unused
22	SYS_CLK	Output	1.8V	19.2 MHz digital clock output	Leave open
23	SLEEP_CLK	Output	1.8V	32.768 kHz digital clock output	Leave open

4.20 TP1 (Boot Pin)

The TP1 pin (boot pin) can be used for two primary purposes:

- The pin can be used to force the module to enter boot-loader mode on power-up — Connect the pin to a control mechanism (for example, a button, switch, or jumper) on the host platform, and use this mechanism to assert (drive low) the TP1 pin on power-up. The boot loader monitors the TP1 pin and when it detects a low signal, prevents normal power-up and prepares to download firmware via the DM port.
When the module has restarted and entered boot-loader mode, make sure to de-assert the TP1 pin. When the firmware download finishes, the module reboots automatically and the de-asserted pin allows the module to boot normally.
- If not connected to a control mechanism, at minimum the pin should be connected to a test point on the host platform, for use by Semtech in RMA debugging.

Note: Firmware downloads also occur using software tools available on <http://source.sierrawireless.com> or over the air using an AirVantage server.

Table 4-26: TP1 Pin Description

Pin	Name	Direction	Function	If Unused
47	TP1	Input	Device recovery (boot load)	Mandatory test point

4.21 Temperature Monitoring

The Semtech RC76xx provides internal temperature monitoring of the module's baseband thermistor, as detailed below in Figure 4-29 and Table 4-27.

The temperature state can be queried directly, and unsolicited notifications of temperature state transitions can be received by using:

- **AT!PCTEMP** — Display the current temperature state (normal, hi or low warning, hi or low critical).
- **AT+WUSLMSK** — Enable unsolicited notifications for **!PCTEMP**, to be received over the AT port whenever the state changes.

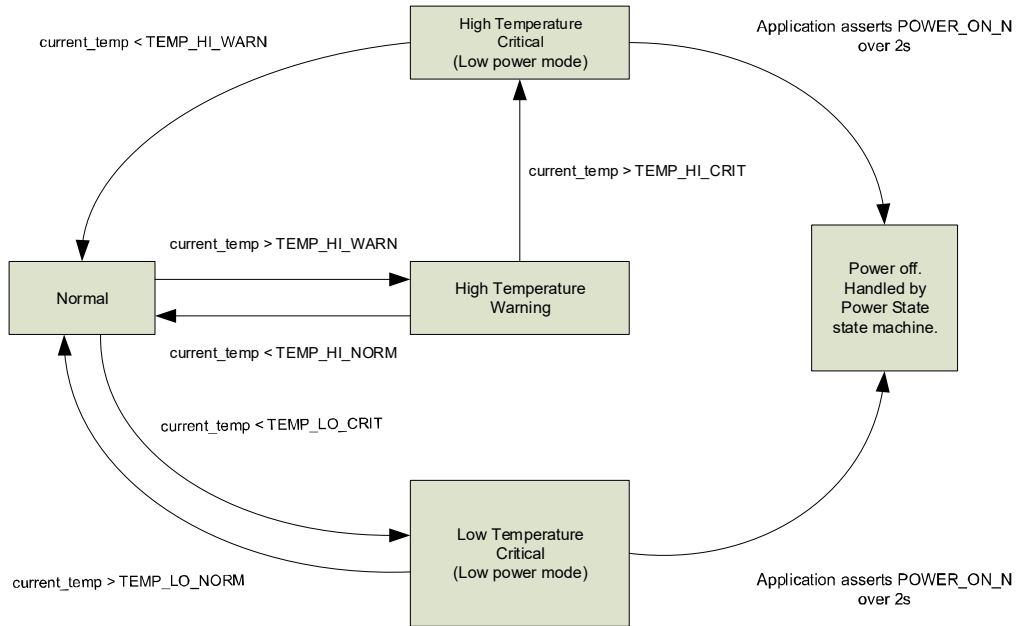

Figure 4-29: Temperature Monitoring State Machine

Table 4-27: Temperature Monitoring States

State	Description	Threshold	Default Temp Value (C) ^a	Functionality
Normal	PA thermistor is between	TEMP_HI_NORM	+100	Class A
		TEMP_LO_NORM	-40	Class B
High Temperature Warning	PA thermistor has exceeded	TEMP_HI_WARN	+105	Class B
High Temperature Critical	PA thermistor has exceeded	TEMP_HI_CRIT	+110	Low Power Mode
Low Temperature Critical	PA thermistor has descended past	TEMP_LO_CRIT	-45	Low Power Mode

a. Junction (PA thermistor) temperature

To restore full operation, the PA thermistor’s temperature reading must be within the normal or high temperature warning state thresholds.

4.22 Test Pins

Semtech requires test points on the customer application for Semtech RMA and debug service.

Table 4-28: Mandatory Test Pins

Pin	Name	Function	If Unused
236	J1	Test point	Mandatory test point
237	J2	Test point	Mandatory test point
238	J3	Test point	Mandatory test point
239	J4	Test point	Mandatory test point
240	J5	Test point	Mandatory test point
241	J6	Test point	Mandatory test point
242	J7	Test point	Mandatory test point
243	J8	Test point	Mandatory test point
244	J9	Test point	Mandatory test point

Table 4-29: Recommended Test Pins

Pin	Name	Function	If Unused
3	UART1_RTS	UART1	Strongly recommended (almost mandatory) for debug purposes
4	UART1_CTS	UART1	Strongly recommended (almost mandatory) for debug purposes
5	UART1_TX	UART1	Strongly recommended (almost mandatory) for debug purposes
6	UART1_RX	UART1	Strongly recommended (almost mandatory) for debug purposes
11	RESET_IN_N	Control signal	Adding a test point is recommended
12	USB_D-	USB	Strongly recommended (almost mandatory) for debug purposes
13	USB_D+	USB	Strongly recommended (almost mandatory) for debug purposes
16	USB_VBUS	USB	Strongly recommended (almost mandatory) for debug purposes
26	UIM1_VCC	UIM1	Recommended
27	UIM1_CLK	UIM1	Recommended
28	UIM1_DATA	UIM1	Recommended
29	UIM1_RESET_N	UIM1	Recommended
45	VGPI0	Voltage reference	Strongly recommended (almost mandatory) for debug purposes
46	Ext_SIM_switchg / GPIO6 / RESET_OUT_N	UIM1	Recommended
47	TP1 (Boot pin)	Control Signal	Should be connected to a test point

Table 4-29: Recommended Test Pins (Continued)

Pin	Name	Function	If Unused
59	POWER_ON_N	Control Signal	Strongly recommended (almost mandatory) for debug purposes
64	UIM1_SIMA_DET	UIM1	Recommended
65	UIM1_SIMB_DET / GPIO4	UIM1	Recommended
96	UART2_TX	UART2	Recommended
97	UART2_RX	UART2	Recommended
98	UART2_RTS	UART2	Recommended
99	UART2_CTS	UART2	Recommended
151	W_DISABLE_N	Control Signal	Recommended

4.23 Antenna Control

The Semtech RC76xx provides four output signals that can be used for host designs that incorporate tunable antennas.

Note:

- It is the responsibility of developers of host designs to evaluate the performance of tunable antennas that use these signals for neighbor cell measurements, Inter-RAT handovers, etc. Semtech does not guarantee ANT_CNTLx signal timing.
- Antenna control signals support is optional.
- These pins can be configured for use as GPIOs using **+WIOCFG**.

Table 4-30: Antenna Control Signals

Pin	Name	Direction ^a	Function	If Unused
153	ANT_CTRL0	Output	Customer-defined external switch control for tunable antennas	Leave open
154	ANT_CTRL1	Output		Leave open
155	ANT_CTRL2	Output		Leave open
156	ANT_CTRL3	Output		Leave open

a. Signal direction with respect to module. Examples: ANT_CTRL0 (pin 153) is an output from the module to the host.

To tune the antenna:

1. Enable band selection, which is required to tune the antennas for specific bands:
AT!CUSTOM="BANDSELEN",1
 Note that this setting is persistent unless disabled by issuing
AT!CUSTOM="BANDSELEN",0.
2. Drive the antenna control signals high or low, as required, for a specific band: **AT!ANTSEL=<band>, <gpio1>, <gpio2>, <gpio3>[, <gpio4>]**
 See RC76xx AT Command Reference for details.
 Note that <gpio1>–<gpio4> correspond to ANT_CTRL0–ANT_CTRL3.

4.24 Indication Interfaces

The Semtech RC76xx provides several indication interfaces that deliver notifications when specific events occur. These interfaces include:

- Tx Activity Indicator (TX_ON)
- WWAN_LED_N
- WAKE_ON_WWAN
- Ring Indicator
- SAFE_PWR_REMOVE

4.24.1 Tx Activity Indicator (TX_ON)

The Semtech RC76xx provides a digital output signal to indicate the occurrence of Tx activity.

Table 4-31: Tx Activity Indicator States

Pin	Signal Name	Direction ^a	I/O Type	Module State	Signal State
60	TX_ON	Output	1.8V	During Tx activity	High
				No Tx	Low

a. Signal direction with respect to module—TX_ON (pin 60) is an output from the module to the host.

Table 4-32: Tx Activity Indicator Characteristics

Parameter	Min.	Max.
T_{advance}	64.8 ms (LTE) 20 ms (3G) / 150 us (2G)	-
T_{delay}	-	33.8 ms(LTE) 800 ms (3G) / 50 us (2G)

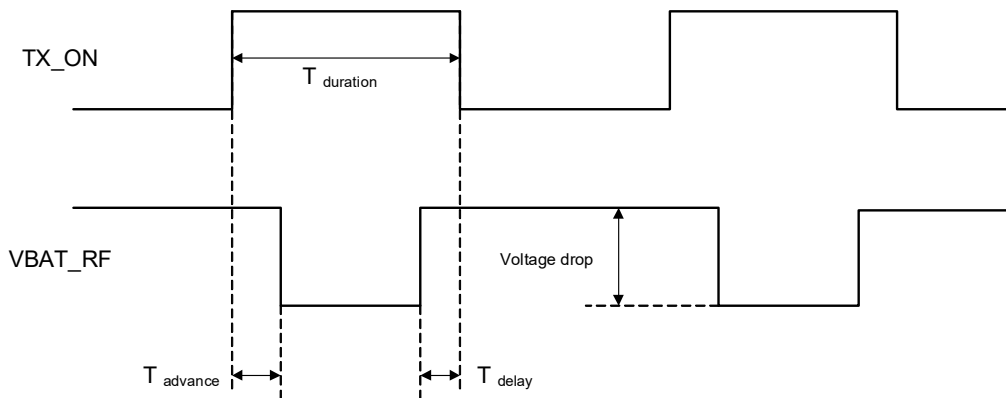

Figure 4-30: TX_ON State During Transmission

4.24.2 WWAN_LED_N

The Semtech RC76xx provides a LED control output signal pad.

Table 4-33: LED Interface Pin

Pin	Signal Name	Direction	Voltage / Current	Function	If Unused
106	WWAN_LED_N	Output	<ul style="list-style-type: none"> Voltage (max)=Typical output range: 0.3 to VBAT_BB Maximum current sink capability=40 mA 	LED driver control	Leave open

4.24.3 WAKE_ON_WWAN

Note: Host support for WAKE_ON_WWAN signal is optional.

The Semtech RC76xx drives WAKE_ON_WWAN high to wake the host when it receives specific events such as incoming SMS or incoming data packets. This pin can be configured by using **AT!CUSTOM** command with the option: **WAKEHOSTEN**. For details, please see the RC76xx AT Command Reference Guide.

See [Figure 4-31](#) for a recommended implementation.

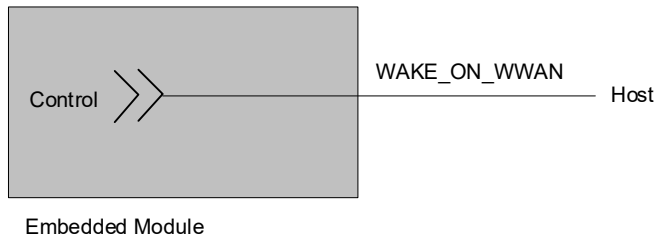

Figure 4-31: Recommended WAKE_ON_WWAN Connection

Note: WAKE_ON_WWAN for incoming data packets is based on the host driver QMI event registration (using QMI_WDS_SET_EVENT_REPORT). For Linux Host, the WDS event reporting indicator must be enabled by the Linux SDK application (for example, MBPL SDK application). This will ensure that this pin is triggered.

4.24.4 Ring Indicator

The ring indicator (UART1_RI) may be used to notify an external application of several events such as an incoming call, timer expiration, or incoming SMS. The Semtech RC76xx pulses the signal low when an event occurs. It can be used independently from the UART1 interface.

Table 4-34: Ring Duration Time

Parameter	Time
Pulse width	50 ms

Note: The pulse width duration is based on the current FW setting and can be configured using the AT command: AT+WRID.

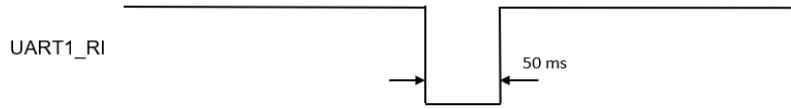

Figure 4-32: UART1_RI

Table 4-35: UART1_RI Pin

Pin	Name	Direction ^a	Function	If unused
2	UART1_RI	Output	<ul style="list-style-type: none"> Ring Indicator Signal incoming calls (voice and data), SMS, etc. 	Leave open

a. Signal direction with respect to the module — UART1_RI (pin 2) is an output from the module to the host.

Important: Do not install an external pull-up on this pin, otherwise the module will not boot.

Note:

- Pin status is in internal pull-down when the module boots or resets.
- RI supports events which toggle the RI signal. This pin can be configured using the AT+WWAKESET AT command.

4.24.5 SAFE_PWR_REMOVE

The SAFE_PWR_REMOVE signal is provided by Semtech RC76xx to indicate to the host device that the main power supply (VBATT) can be safely turned off after a positive pulse.

Table 4-36: SAFE_PWR_REMOVE Duration Time

Parameter	Time
Pulse width	13.26 ms
Duration time from the falling edge of SAFE_PWR_REMOVE signal to VGPIIO off	7.8 ms

Note:

- All host interfaces connected to the module must be disabled (high Z or pull-down) before turning off VBATT. This prevents leakages and bad power on sequences.
- Consider the VGPIIO discharge time (depends on the load on the host equipment) before switching off VBATT.

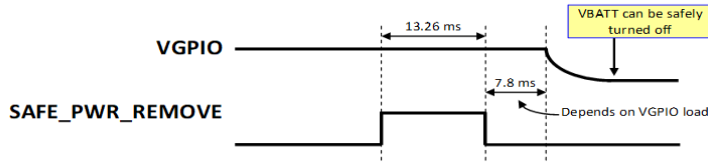

Figure 4-33: SAFE_PWR_REMOVE

4.25 DR_SYNC

The Semtech RC76xx provides DR_SYNC, an output used for GPS dead reckoning synchronization. The module pulses the DR_SYNC signal once every integer GPS second. While position fixes are occurring, the DR_SYNC pulse is aligned precisely with the GPS time. When a position fix cannot be made (for example, when a vehicle has entered a tunnel), the module continues to pulse the DR_SYNC signal every second while the level of uncertainty of the GPS time is low. When the uncertainty level is high, the module stops pulsing the signal.

Table 4-37: DR_SYNC Pin Details

Pin	Signal Name	Direction ^a	Function	If Unused
42	DR_SYNC	Output	GPS dead reckoning sync signal	Leave open

a. Signal direction with respect to the module—DR_SYNC (pin 42) is an output from the module to the host.

Pin status is in internal pull-down when the module boots or resets.

4.26 W_DISABLE_N — Wireless Disable

Note: Host support for wireless disable signals is optional.

The host device uses W_DISABLE_N (pin 151) to enable / disable the WWAN or radio modem. When disabled, the modem cannot transmit or receive information. Letting this signal float high allows the module to operate normally. The pin has an internal pull-up resistor. See Figure 4-34 for a recommended implementation.

When integrating with your host device, keep the following in mind:

- The signal is an input to the module and should be driven LOW only for its active state (controlling the power state); otherwise it should be floating (or high impedance). It should never be driven to a logic high level. The module has an internal pull-up resistor to an internal 1.8V rail, so if the signal is floating or (high impedance), then the radio is on.

- If the host never needs to assert this power state control to the module, leave this signal unconnected from the host interface.

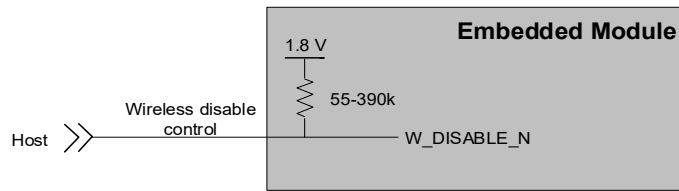

Figure 4-34: Recommended Wireless Disable Connection

5: Routing Constraints and Recommendations

This section describes general routing constraints and recommendations for the Semtech RC76xx module.

Note: This is a non-exhaustive list of suggested design guidelines. The developer is responsible for deciding whether to implement these guidelines.

5.1 General Rules and Recommendations

Clock and other high-frequency digital signals (e.g. serial buses) should be routed as far as possible from the module's analog signals.

If the application design makes it possible, all analog signals should be separated from digital signals by a ground trace on the PCB.

Note: Avoid routing any signals under the module on the application board.

5.2 Power Supply

When designing the power supply, make sure that VBAT_BB/VBAT_RF meet the requirements listed in [Power Supply Ratings](#).

Careful attention should be paid to the following:

- Power supply noise — PFM systems should be avoided; Low ripple, linear regulation or PWM converters are preferred for low noise.
- High switching load capability to deliver high current peaks in a short time (for TDMA frames—RC7620 and RC7620-1 only). For details about the input capacitor, see [Power Supply](#)
- Power supply and power tracks design must support peak currents with an acceptable voltage drop that guarantees the minimum required VBATT value.
- Voltage applied on VBATT signal pads must never exceed the voltage range defined in [Power Supply Ratings](#), otherwise the module's power amplifier and GPS chipset may be severely damaged.
- A weakly-designed (not robust) power supply could affect EMC performance, the radiated spurious emission (RSE), and the phase error and frequency error.

5.3 Antenna

Semtech strongly recommends working with an antenna manufacturer either to develop an antenna adapted to the application, or to adapt an existing solution to the application. Refer to [Table 3-30](#)

For information on routing constraints for the RF circuit, see [RF Routing Recommendations](#).

5.3.1 OTA Considerations when Developing Products with an Integrated Antenna

Developing a product with an integrated antenna is challenging considering RF design and performances; difficulty increases with the level of integration. Smaller product size implies:

- The smaller the antenna, the more challenging to reach the expected antenna efficiency.
- Large RF TX signal level radiated by the antenna can be captured by nonlinear devices and create, by rectification, a high level of unwanted harmonics.
- As much as the distance between the antenna and electronic devices (including the module and other application related hardware) decreases, coupling to clocks and DC/DC switchers harmonics and wide band noise sources generated by high speed digital signals increases. Such a coupling may create receiver desensitization from the resulting noise generated at the receiver frequency bands.

It is essential to take into account appropriate design rules when developing new products and to evaluate OTA performances at an early stage of product integration:

- TRP (Total Radiated Power): To verify the antenna efficiency at TX frequency bands and compliance to spurious emission requirements.
- TIS (Total Isotropic Sensitivity): To verify the antenna efficiency at RX frequency bands and evaluate the presence of noise generated into supported frequency bands subject to cause receiver desensitization.

5.4 PCB Layout Recommendations

5.4.1 General Design Rules

- Application board should be designed in such a way that provides a plain GND connection on the whole surface located under the module area. A matrix of high density vias should be implemented to connect the top layer (in contact to the module LGA ground pads) to other GND layers. Such implementation aims to reduce noise interference, spurious radiation and improve heat dissipation spreading heat through the PCB surface and layers.
- To reduce coupling between antenna and other signals and improve EMC, the top and bottom layers of the PCB should be covered by solid GND plan as much as possible.
- Good PCB grounding is essential; use ground planes that are as wide as possible and link the different GND planes from each layers using regularly spaced via holes. The maximum recommended distance between two consecutive vias.

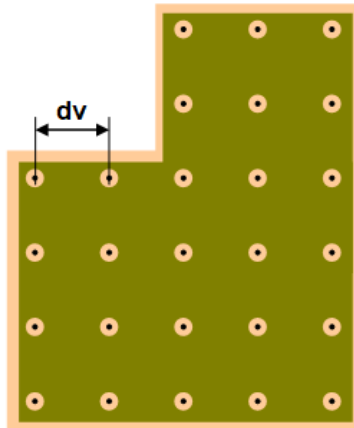

The “dv” distance between two GND vias should be calculated using the empirical equation below:

$$dv \leq \frac{1}{10} \cdot \frac{\lambda_g}{4} = \frac{1}{40} \cdot \lambda_g$$

$$\text{With } \lambda_g = \frac{c}{F_{\max} \cdot \sqrt{\epsilon_r}}$$

c = velocity of light $\approx 300 \cdot 10^9$ mm/s

F_{\max} = Highest frequency used on the application

ϵ_r = relative permittivity (dielectric constant) of PCB

So for a 2GHz / FR4 application, dv should be :

$$dv_{2,7GHz,FR4} = \frac{1}{40} \cdot \frac{300}{2,7 \cdot \sqrt{4,6}} \approx 1,3mm$$

- Particularly, via should be present all around the PCB edge to block any unwanted EMI emitted from the internal layers. Usually power planes are not recommended. We recommend a distributed power supply instead.



- Sensitive signals should be shielded by routing them into inner layers (to prevent them from radiating) and sensitive components can be shielded. The top and bottom ground plans connected together with vias ensures all sensitive traces are shielded well. This significantly reduces coupling between antenna and other signals and improves EMI and EMC performances.
- When it is not possible to route a signal trace into inner layers, top and bottom layers can be used for short distance connections (i.e. connections between adjacent pads).
- It is good practice during the design phase to anticipate and reserve area for shield cans.
- The module’s power supply needs decoupling capacitors to filter out noise to prevent it from reaching the module. It could cause instabilities in the RF output in the transmitter, resulting in undesired interference and spurious radiations. In the receiver, it increases packet error and reduces sensitivity.
- Place a decoupling capacitor (10–33pF is recommended) as close to the power supply pin of the module as possible.
- Use as many vias as possible to build a ground fence around the RF stripline and microstrip line to isolate it from other signals.
- In some specific cases, like impedance controlled lines and RF connection pads and antenna pads, sufficient keep out distance between RF signals and GND should be implemented to prevent impedance mismatch from parasitic capacitance load.

5.4.2 Specific Design Rules to Support TRP Performances

- Prevent neighboring components from being interfered by TX radiated RF energy to prevent them from generating harmonics through non-linear behavior such as saturation or rectification. The mandatory maximum radiated harmonics level for R&TTE/PTCRB certification is below -30dBm and can be very easily failed with inappropriate design.

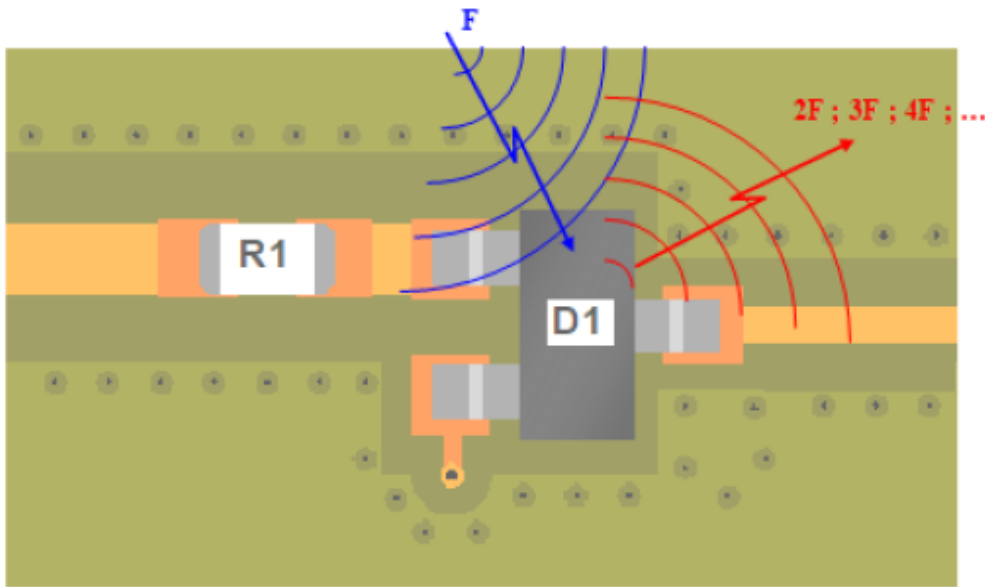

- When possible, add 10-47pF in parallel of each fast rectifier diode to prevent generating harmonics (due to the TX signal detection).

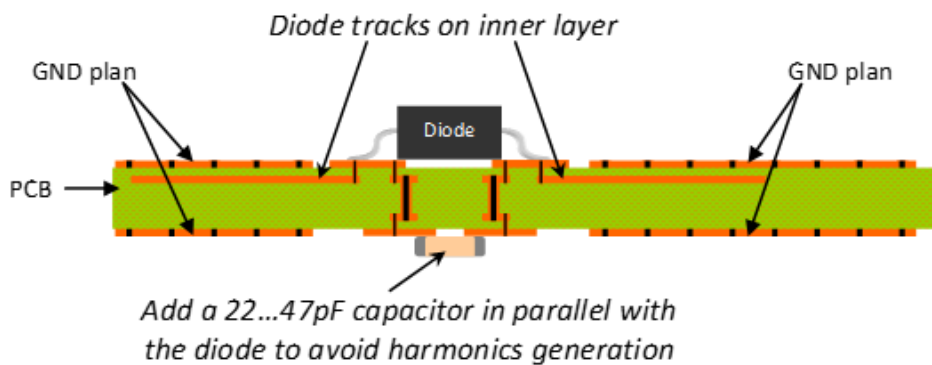

- With an antenna located close to circuitry using active devices, shielding may be needed to reach enough isolation.

5.4.3 Specific Design Rules to Support TIS Performance

- High speed digital signal (such as DC/DC converters, system clock, CPU and Memory bus, USB and other high speed interfaces) should be routed on inner layers and located as far as possible from RF signals and antenna.
- Good practice for interferences prevention is to add decoupling capacitors (10–33pF recommended) every 10mm on all top and bottom power lines longer than 10mm.
- With an antenna located close to circuitry using active devices or noisy signals, shielding may be needed to reach enough isolation.

5.5 PCB Specifications for the Application Board

Digital and sensitive signals (such as audio, UIM, clocks, high speed interface) should be routed on the inner layers and separated from each other by GND tracks regularly punctured with vias (or microvias). Routing sensitive signals close to noisy signals could result in noise being coupled.

The clocks (SYS_CLK and SLEEP_CLK) should use a 50 Ohm controlled impedance trace and the length must be as short as possible.

5.6 Recommended PCB Land Pattern

Refer to document RC76xx Customer Process Guidelines, available at <http://source.sierrawireless.com>.

5.7 Routing Constraints

5.7.1 Power Supply

Note: The recommended output current capability for the power supply on Table 3-3 on page 28 includes margin.

If the following design recommendations are not followed, phase error (peak) and power loss could occur.

- The trace widths of the power supplies (VBAT_BB and VBAT_RF) should be as wide as possible to minimize voltage drops and reduce electromagnetic interference risks.

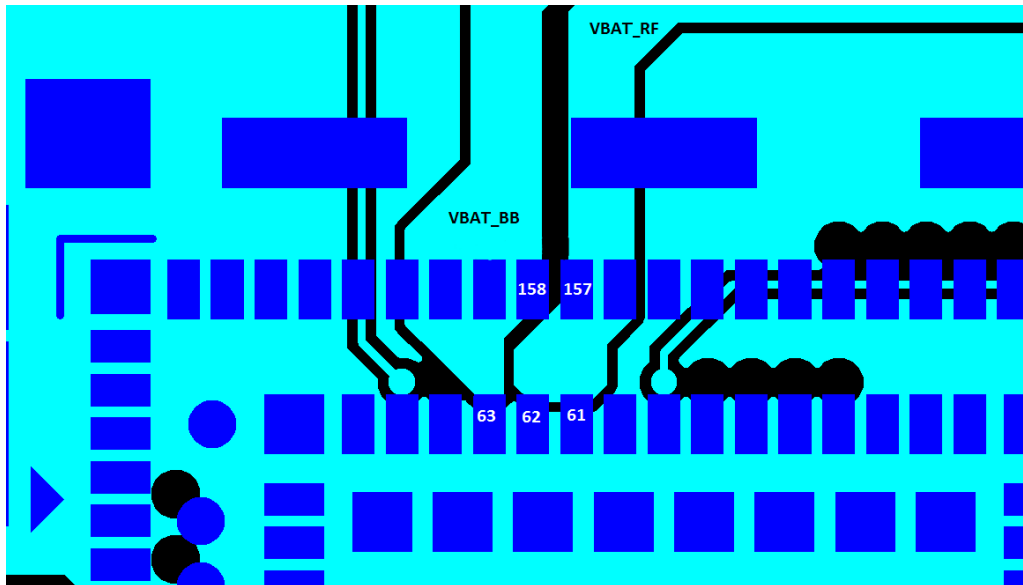

Figure 5-1: Power Supply Routing Example

Note: [Figure 5-1](#) shows separate traces for VBAT_BB and VBAT_RF. If VBAT_BB and VBAT_RF share a single power supply, these traces should be connected.

Note: For optimal decoupling, place the capacitors on the underside of the board, directly under the pins.

- Input capacitors ($2 \times 47 \mu\text{F}$) are required close to the module.
 - Attention should be paid to the ground trace or the ground plane on the application board for the power supply that supplies the module. The ground trace or ground plane, as well as the VBATT trace, must be able to support current peaks.
 - If the ground trace between the module and the power supply is a copper plane, make sure it is a solid plane.
 - Design routing to make sure total line impedance does not exceed $10 \text{ m}\Omega$ @ 217 Hz.
-

Note: 2G GSM communications use intermittent burst signals with a period of 4.615 ms (217 Hz)

5.7.1.1 Ground Plane Connection

The Semtech RC76xx requires a solid, central ground plane (with solder mask defined pads) located directly under the module. This will:

- Ensure high current signal returns
- Provide heat dissipation under higher operating temperatures

The ground plane should be connected (with vias) to the reference ground layer of the application board.

Do not use a separate GND for the antennas. Connections to GND from the Semtech RC76xx module should be flooded plane using thermal reliefs to ensure reliable solder joints.

5.7.2 UIM Interface

- Tracks between the module and the UIM socket should be as short as possible and routed on inner layers. Maximum recommended length is 10 cm.
- The ESD must be placed near the UIM holder
- ESD protection is mandatory on the UIM lines unless:
 - An external eSIM is being used, or
 - There is no physical access to the UIM.
- The decoupling capacitor(s) should be placed as close as possible to the UIM card connector for the UIM1_VCC signal.

5.7.3 RF Routing Recommendations

For radiofrequency signals, the following recommendations shall be taken into consideration on PCB layout:

- For each antenna interface (RF_MAIN, RF_DIV, RF_GNSS), the related GND pads should be considered as an integrated part of the radio input/output (refer to [Figure 5-4](#) example). Reference ground of the RF traces shall be a solid integrated plane.
- The use of a CBCPW (Conductor-Backed Coplanar Waveguide) is strongly recommended for lower insertion loss, better impedance matching stability and no additional loss due to the use of vias required by the Stripline structure.

The CBCPW must be surrounded by GND planes evenly punched by GND vias:

Conductor-Backed Coplanar Waveguide:

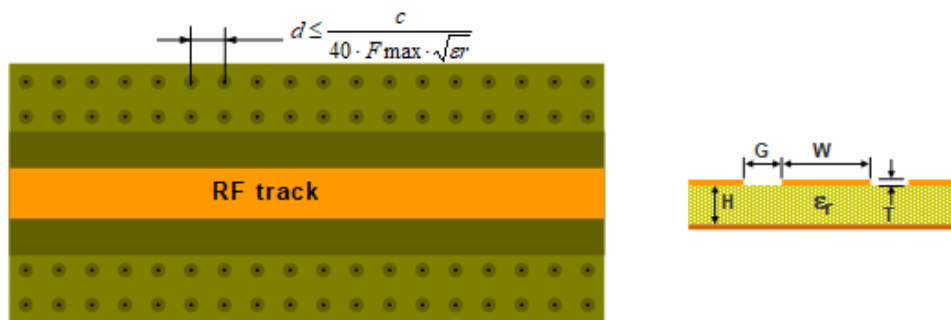

Figure 5-2: Conductor-Backed Coplanar Waveguide (CBCPW) design

- The distance between two adjacent vias should be \leq the quarter wavelength / 10 of the highest frequency carrier.
- The CBCPW design for RF trace must be used for better isolation, and the coplanar clearance (G, below) from the trace to the ground should be at least the trace width (W) and at least twice the height (H). This reduces the parasitic capacitance, which potentially alters the trace impedance and increases the losses.

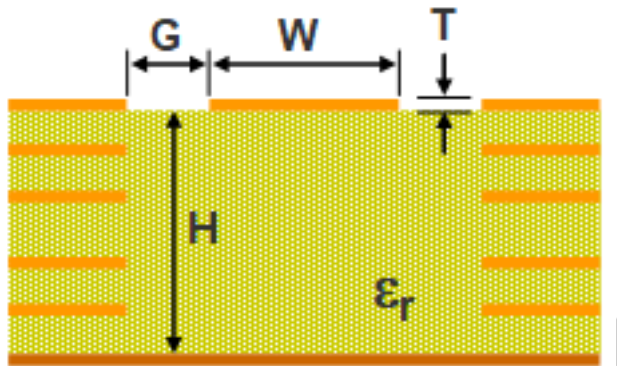

Figure 5-3: Coplanar Clearance example

Note: The figure above shows several internal ground layers cut out, which may not be necessary for every application.

- As far as possible and in order to avoid impedance breaks, choose a track width at least equal size of the component pad connected to it.

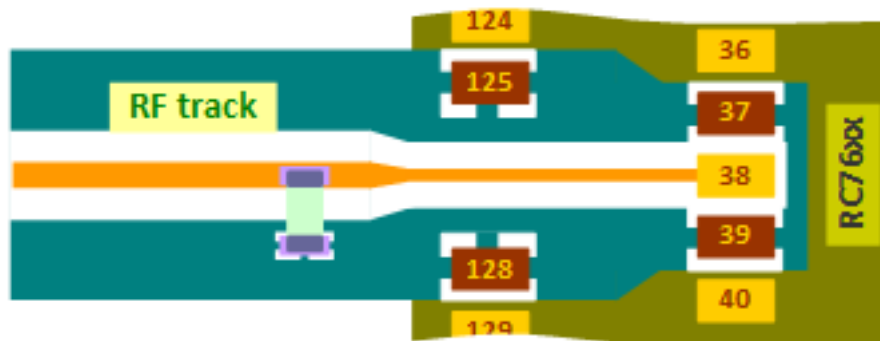

Figure 5-4: Track width and component pad

- Because a part of the RF track is routed under the module, the RF track width shall be slightly reduced before going under the module for considering the metallic mass of the module. Thus, under the module, the structure of the RF line becomes a stripline.
- Anticipate a copper keep-out under the RF pads to reduce stray capacitance losses.

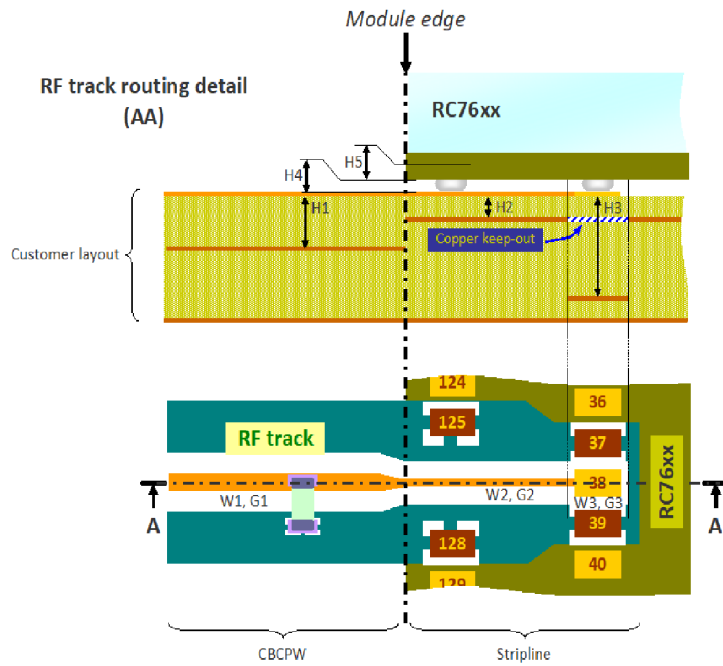
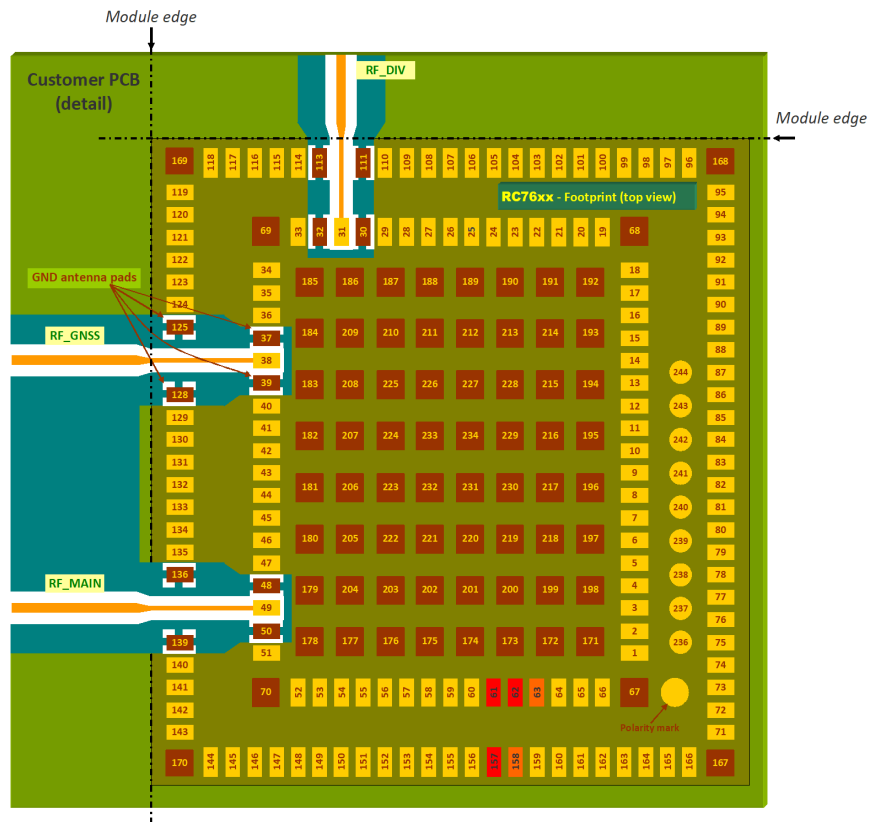

Figure 5-5: RF Tracks Routing

- All RF traces must be well isolated to other “noise” circuits such as USB, PCIe, external XO, DC power supply, etc.
- Edge mount RF connectors are strongly suggested for better impedance matching.



Figure 5-6: RF Connector

- Different layers routing design with vias transition is not recommended as they will introduce more RF losses.
- Do not use right angle RF tracks. A 90° mitered bend is recommended:

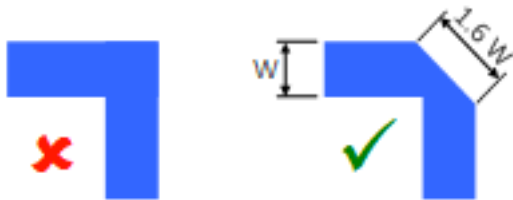

Figure 5-7: RF tracks - Example of optimally 90° mitered bend routing

5.7.4 USB Interface

When the USB interface is externally accessible, ESD protection is required on the USB_VBUS, USB_D+, and USB_D- signals.

HS-USB guidelines:

- Up to 480 Mbps data rate.
- 90Ω differential, ± 10% trace impedance.
- Differential data pair matching < 3.8 mm (150 mils).
- Other comments and guidelines:
 - External components should be located near the USB connector.
 - Relatively fast edge rates, so they should be routed away from sensitive circuits and signals (RF, system clock).
 - VBUS trace width must be sized depending on the length of VBUS and the expected current.
 - Loading on the USB DP/DM lines could cause USB receiver sensitivity issues. Perform USB electrical tests (eye diagram and receiver sensitivity) to ensure proper USB functionality.
 - It is not recommended to install series switches on the USB lines.
 - Trace width and trace spacing for DP and DM based on impedance calculator. Avoid discontinuity. The trace width should be equal from source to destination. Keep impedance constant.
 - Avoid having multiple vias. Vias are a source of discontinuity, which can cause signal reflection.
 - Avoid crossing different power plane if possible for USB signals. This caused an unpredictable return path current and cause a signal quality issue.

- Avoid stubs. A common routing mistake is to create a stub by connecting a component on the DP or DM traces.
- Adding test points on USB traces must comply with radio frequency signal routing rules to avoid degradation of USB signal quality.
- The USB power supplies should have wider traces and not narrow traces, which cause IR drop. This affects the jitter performance of the USB signal.

5.8 Thermal Considerations

When transmitting, the Semtech RC76xx can generate significant amounts of heat (due to the internal Power Amplifier) that must be dissipated in the host device for safety and performance reasons.

The amount of thermal dissipation required depends on the following factors:

- Supply voltage — Maximum power dissipation for these modules can be up to 3 W at voltage supply limits.
- Usage — Typical power dissipation values depend on the location within the host, amount of data transferred, etc.

To enhance heat dissipation:

- Maximize airflow over / around the module
- Locate the module away from other components that generate heat
- Ensure the module is connected to a solid ground plane

5.9 EMC and ESD Recommendations

EMC tests must be performed on the application as soon as possible to detect any potential problems.

When designing, special attention should be paid to:

- Possible spurious emissions radiated by the application to the RF receiver in the receiver band
- ESD protection — Typically, ESD protection is mandatory for externally accessible signals, including:
 - VBAT_RF/VBAT_BB
 - UIM (if accessible from outside)
 - Serial link
 - USB
 - Antennas
- Length of the UIM interface lines (preferably <10 cm)
- Ground plane: Semtech recommends a common ground plane for analog/digital/RF grounds

Note: The Semtech RC76xx does not include any protection against over-voltage.

The host device must provide adequate ESD protection on digital circuits and antenna ports as detailed in the following table.

Note: The level of protection required depends on your application.

Table 5-1: ESD Specifications^a

Category	Connection	Specification
Operational	<ul style="list-style-type: none"> ▪ RF ports ▪ UIM connector ▪ USB connector ▪ UART connector 	IEC-61000-4-2 - Level (Electrostatic Discharge Immunity Test) <ul style="list-style-type: none"> ▪ ± 6kV Contact ▪ ± 8kV Air
Non-operational	Host connector interface	Unless otherwise specified: <ul style="list-style-type: none"> ▪ JESD22-A114 ± 1kV Human Body Model ▪ JESD22-A115 ± 100V Machine Model ▪ JESD22-C101C ± 500V Charged Device Model

a. ESD protection is highly recommended at the point where the UIM contacts are exposed, and for any other signals that would be subjected to ESD by the user.

5.10 Mechanical Integration

Attention should be paid to:

- Antenna cable integration (bending, length, position, etc)
- Pads of the Semtech RC76xx to be soldered to the ground plane
- Ensuring proper board layout
- Providing sufficient space around the module for heat dissipation

5.11 Signal Reference Schematics

5.11.1 UIM Holder

Figure 5-8 illustrates the recommended implementation of a UIM holder.

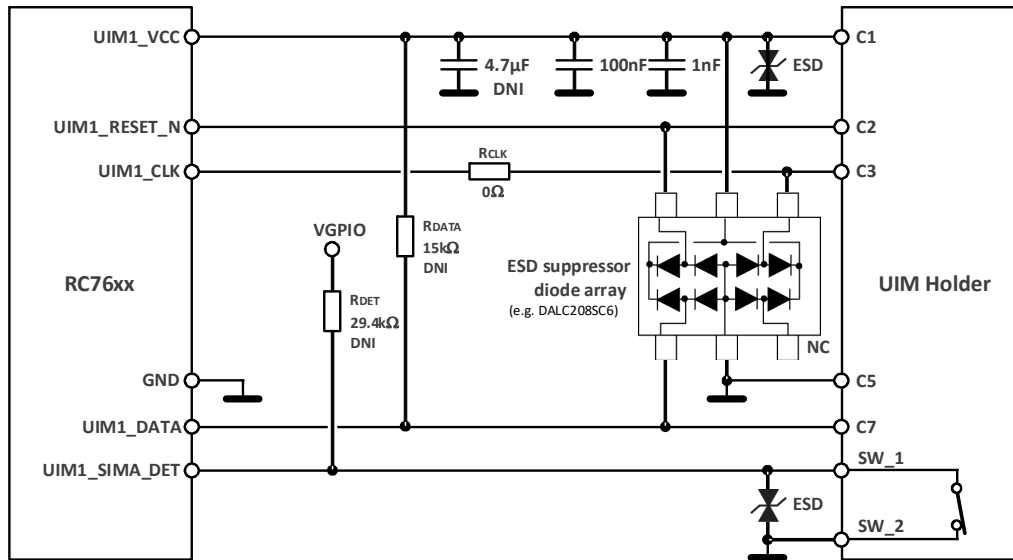

Figure 5-8: Recommended Single UIM Holder Implementation

The UIM1 Detect signal (UIM1_SIMA_DET) is used to detect the physical presence of a UIM card in the UIM holder. The signal has a 470 k Ω pull-up internal to the module. It should be set to GND when a UIM is not present. The UIM Detect signal transitions:

- When a UIM is inserted — high (logic 0 to logic 1)
- When a UIM is removed — low (logic 1 to logic 0)

The capacitor and the two resistors, RCLK and RDATA, should be added as placeholders to compensate for potential layout issues. UIM1_DATA trace should be routed away from the UIM1_CLK trace. Keep the distance between the module and the UIM holder as short as possible.

All signals near the UIM holder must be ESD-protected.

An ESD device specifically designed for UIM cards is recommended for the UIM1 VCC, RESET_N, CLK, and DATA signals (for example, STMicroelectronics DALC208SC6). For UIM1_SIMA_DET a low leakage ESD suppressor should be selected.

This schematic also applies to the external UIM2 of RC7612 and RC7612-1 (Limited Availability).

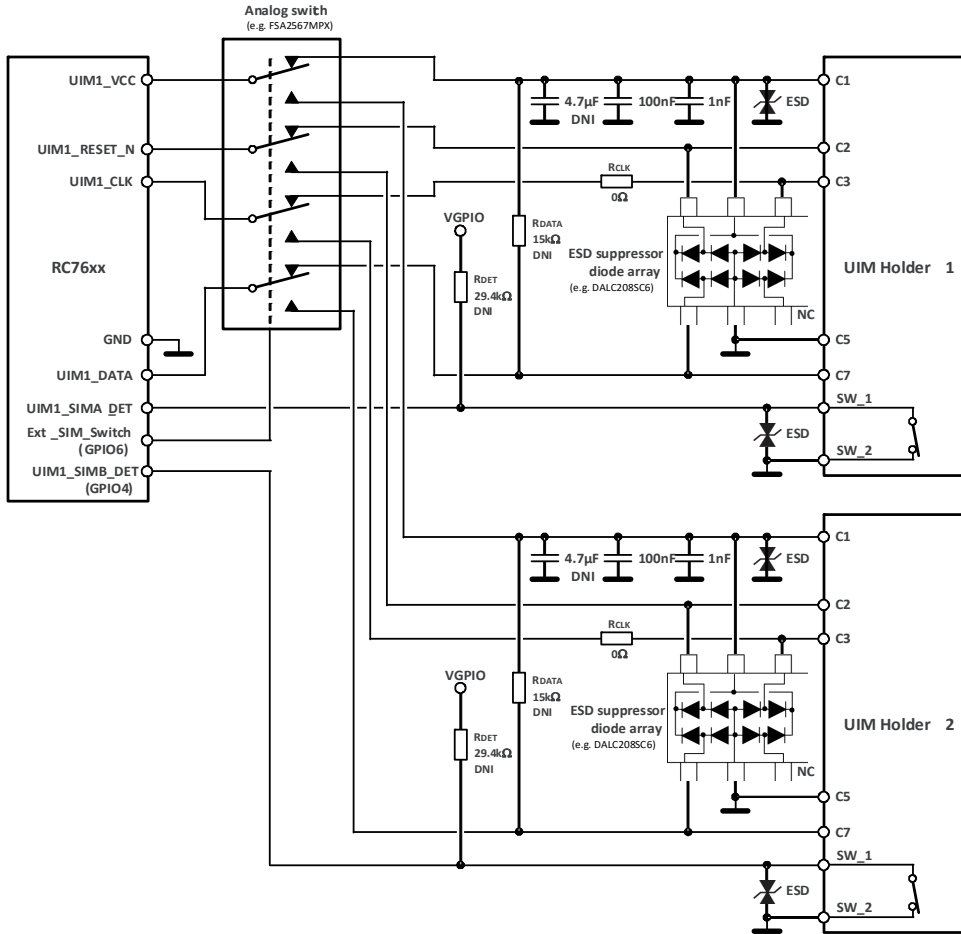

Figure 5-9: External SIM schematic for RC7611, RC7611D, RC7620, RC7630, and RC7630J*
 * Limited availability

5.11.2 USB

USB2.0 Interface Example

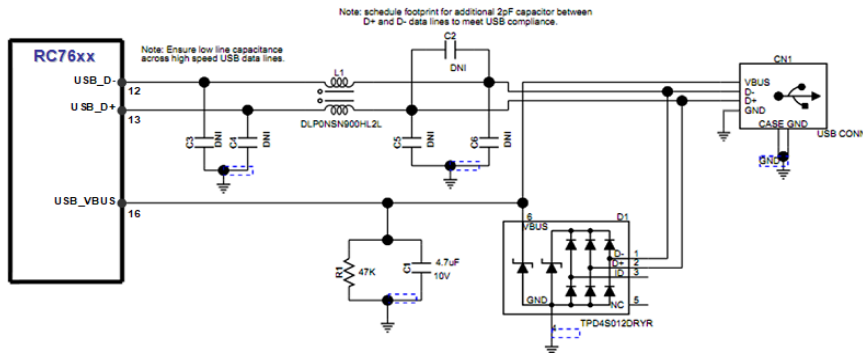

Figure 5-10: USB Interface

6: Software and Tools

6.1 Support Tools

The Semtech RC76xx is compatible with Semtech' SwiLogPlus trace tool that allows users to send error logs to Semtech.

6.2 SED (Smart Error Detection)

The Semtech RC76xx uses a form of SED to track premature module resets. In such cases, the module automatically forces a pause in boot-and-hold mode at power-on to accept an expected firmware download to resolve the problem.

1. Module tracks consecutive resets within 30 seconds of power-on.
2. After a sixth consecutive reset, the module waits in boot-and-hold mode (up to 30 seconds) for a firmware download to resolve the power-cycle problem.

A RAM dump tool that can be used to help isolate the cause of premature resets is available from Semtech. Contact your Semtech account representative for assistance.

6.3 Firmware Upgrade

Firmware upgrades are downloaded to the embedded module over the USB interface or over the air via Semtech' AVMS (AirVantage Management System). Contact your Semtech account representative for assistance.

6.4 Operating System Upgrade

The Semtech RC76xx module's operating system is stored in flash memory and can be easily upgraded.

Tip: *To follow regular changes in the 3GPP standard and to offer a state-of-the-art operating system, Semtech recommends that the application designed around an embedded module (or embedded module based product) should allow easy operating system upgrades on the embedded module via the recommended firmware download protocol. Therefore, the application shall either allow a direct access to the embedded module USB interface through an external connector or implement any mechanism allowing the embedded module operating system to be downloaded.*

6.5 Product Marking

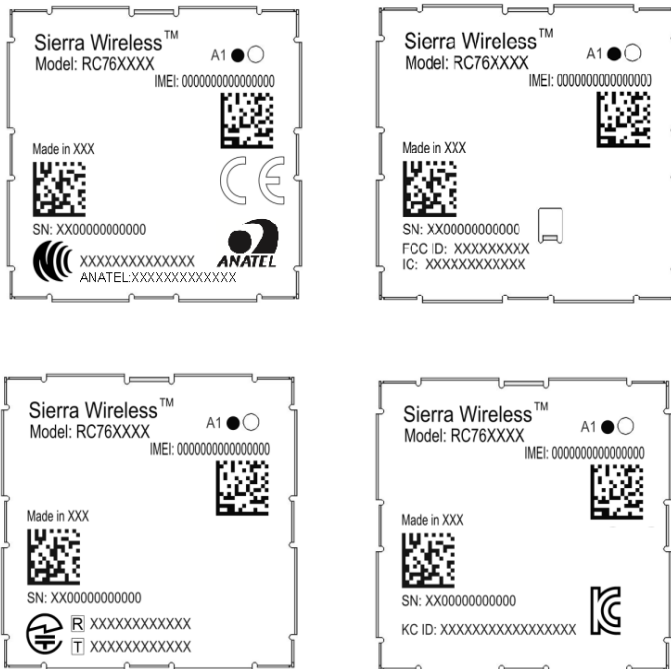

Figure 6-1: Unit Product Marking—Laser-etched, Typical Representation

Note: The figure above is not to scale. Contents will vary by SKU.

The product marking is laser-etched and may contain:

- Product identification (Model name, serial number)
- IMEI or MEID number and barcode
- Fabrication country
- Required regulatory markings (NCC, KCC, CE logo, Japan approval mark, FCC ID, IC certification number, etc., as appropriate)
- Pin 1 indicator

Note: The Semtech RC76xx supports OEM partner specific product marking requirements.

7: Debug and Assembly Considerations

7.1 Testing Assistance Provided by Semtech

Semtech offers optional professional services based assistance to OEMs with regulatory approvals.

7.2 Integration Requirements

When integrating the Semtech RC76xx, the following items must be addressed:

- Mounting — Effect on temperature, shock, and vibration performance
- Power supply — Impact on battery drain and possible RF interference
- Antenna location and type — Impact on RF performance
- Regulatory approvals — As described in [Approval](#)
- Service provisioning — Manufacturing process

Semtech provides guidelines for successful module integration with the document suite and offers integration support services as necessary.

7.3 IOT / Operator

Interoperability and Operator/Carrier testing of the finished system is the responsibility of the OEM. The test process will be determined with the chosen network operator(s) and will be dependent upon your business relationship with them, as well as the product's application and sales channel strategy.

Semtech offers assistance to OEMs with the testing process, if required.

7.4 Module Testing Recommendations

When testing your integration design:

- Test to your worst case operating environment conditions (temperature and voltage)
- Test using worst case operation (transmitter on 100% duty cycle, maximum power)
- Monitor the module's junction temperature using **AT ! PATEMP**. This command polls a thermistor located near the module's power amplifier (typically the hottest spot on the module).

Note: Make sure that your system design provides sufficient cooling for the integrated module. The RF shield temperature should not be exposed to an ambient temperature greater than 85°C to prevent damage to the module's components.

7.5 Serial Link Access

Direct access to the UART1 serial link is very useful for:

- Testability operations
- Accessing the module's console for debugging

Refer to the following figure for a level shifter implementation that allows UART1 serial link access.

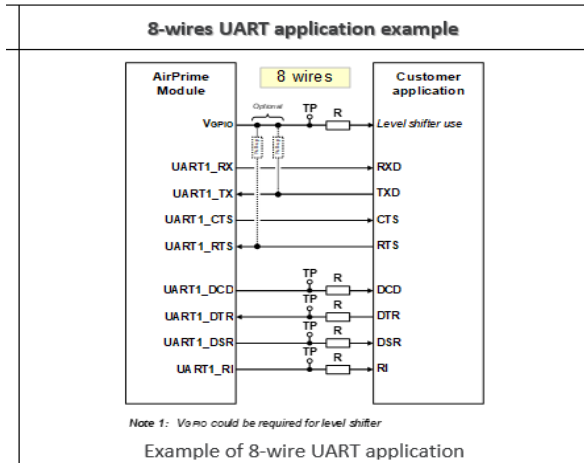

Figure 7-1: UART Application sample

7.6 RF Output Accessibility

During the integration phase of the Semtech RC76xx, it can be helpful to connect the module to a simulator to check critical RF TX parameters and power behavior for supported RATs.

Although the module has been certified, some parameters may have degraded if some basic precautions have not been followed (poor power supply, for example). This may not affect the functionality of the product, but the product may not comply with 3GPP specifications.

The following TX parameters can be checked using a Radio Communication tester:

- Phase & Frequency Error
- Output Power and Burst Time
- Output Spectrum (Modulation and Switching)

The following are available typical Radio Communication testers:

- Rohde & Schwarz: CMU200, CMW500
- Keysight (formerly Agilent): 8960
- Anritsu: MD8475

Because of the high prices associated with Radio Communication testers and the necessary RF know-how to perform simulations, customers can check their applications in the Semtech laboratories. Contact the Semtech support team for more information.

7.7 USB Debug

The USB interface is also used to collect traces for debug purposes. It is highly recommended to reserve test points for collecting trace when USB is not used. Refer to [USB](#) for additional interface description.

8: Reliability Specification

8.1 Functional / Performance Tests

- Operating Condition: Powered
- Test Temperature: Class A and Class B

8.2 Aging Tests

8.2.1 High Temperature Operating Life Test

- Standard: IEC 60068-2-2, Test B: Dry heat
- Test Temperature: 85°C
- Operating Condition: 45 minutes Max Tx/15 minutes Idle
- Duration: 20 days

8.2.2 Humidity Test

- Standard: IEC 60068-2-78, Test Cab: Damp heat, steady state
- Test Temperature: 85°C
- Relative Humidity: 85%
- Operating Condition: 15 minutes Idle/15 minutes Off
- Duration: 10 days

8.2.3 Thermal Shock Test

- Standard: IEC 60068-2-14, Test N: Change of temperature
- Test Temperature: -40°C to 85°C
- Temperature Transition Time: < 30 seconds
- Dwell Time: 10 minutes
- Operating Condition: Unpowered
- Duration: 300 cycles

8.3 Characterization Tests

8.3.1 Electrostatic Discharge Test

- Standard: IEC 61000-4-2: Testing and measurement techniques—Electrostatic discharge Immunity test
- Operating Condition: Powered
- Air Voltage: ±2kV, ±4kV, ±8kV
- Contact Voltage: ±2kV, ±4kV, ±6kV

8.3.2 Low Temperature Cold Start Test

- Standard: IEC 60068-2-1, Test A: Cold
- Test Temperature: -40°C
- Operating Condition: 30 minutes Off/5 minutes Idle
- Duration: 5 days

8.3.3 Electrostatic Discharge Component Test

- Standard: ANSI/ESDA/JEDEC JS-001, ESDA/JEDEC Joint Standard for Electrostatic Discharge Sensitivity Testing, Human Body Model (HBM)—Component Level
- Standard: ANSI/ESDA/JEDEC JS-002, ESDA/JEDEC Joint Standard for Electrostatic Discharge Sensitivity Testing, Charged Device Model (CDM)—Device Level
- CDM: 500 V
- HBM: 2000 V
- Operating Condition: Powered

8.3.4 Unprotected Free Fall Drop Test

- Standard: IEC 60068-2-31, Test Ec: Rough handling shocks, primarily for equipment-type specimens
- Number of Drops: 1 drop per direction ($\pm X$, $\pm Y$, $\pm Z$), 6 directions
- Surface Type: Un-protected drops onto concrete
- Drop Height: 1 meter
- Operating Condition: Unpowered

8.3.5 Component Solder Wettability Test

- Standard: IPC/EAC J-STD-002, Solder Wettability Tests for Component Leads, Terminations, Lugs, Terminals and Wires
- Surface Mount Process Simulation Test (Preconditioning 16 hours ± 30 minutes dry bake)
- Operating Condition: Unpowered

9: Legal Information

This chapter describes the current certification status of the RC7611, RC7611-1, RC7611D, RC7611D-1, RC7612, RC7612-1, RC7620, RC7620-1, RC7630, RC7630-1, and RC7630J* modules collectively referred to as the RC76xx series modules or RC76xx module. Certifications in other countries may be attained upon customer request — contact your Semtech account representative for details.

Additional testing and certification may be required for the host product with an embedded RC76xx series module and are the responsibility of the OEM. Semtech offers professional services-based assistance to OEMs with the testing and certification process, if required.

* *Limited availability*

9.1 Regulatory and Industry Approvals/ Certifications

The RC76xx Series modules are designed to meet, and upon commercial release, will meet the requirements of the following regulatory bodies and regulations, where applicable:

- Federal Communications Commission (FCC) of the United States
- The Certification and Engineering Bureau of Industry Canada (IC)
- (HL7810) The National Communications Commission (NCC) of Taiwan, Republic of China
- Regulatory Compliance Mark (RCM), Electrical Regulatory Authorities Council (Australia and New Zealand)
- Radio Equipment Directive (RED) of the European Union
- Ministry of Internal Affairs and Communications (MIC) of Japan

Upon commercial release, the following industry certifications will have been obtained, where applicable:

- GCF
- PTCRB

Additional certifications and details on specific country approvals may be obtained upon customer request — contact your Semtech account representative for details.

9.2 Compliance Acceptance and Certification

Final regulatory and operator certification requires regulatory agency testing and approval with the fully integrated UE host device incorporating the Semtech RC76xx module.

The OEM host device and, in particular, the OEM antenna design and implementation will affect the final product functionality, RF performance, and certification test results.

Note: Tests that require features not supported by the Semtech RC76xx (as defined by this document) are not supported.

9.3 Certification Compliance

9.3.1 Important Compliance Information for North American Users

The Semtech RC7611, RC7611-1, RC7611D, RC7611D-1, RC7612, and RC7612-1 modules have been granted modular approval for mobile applications. Integrators may use these modules in their final products without additional FCC/IC certification if they meet the following conditions. Otherwise, additional FCC/IC approvals must be obtained.

1. The end product must follow the RF trace routing recommendations on [RF Routing Recommendations](#).
2. At least 20 cm separation distance between the antenna and the user’s body must be maintained at all times.
3. To comply with FCC regulations limiting both maximum RF output power and human exposure to RF radiation, the maximum antenna gain including cable loss in a mobile-only exposure condition must not exceed the limits stipulated in [Table 9-1](#).

Table 9-1: Antenna Gain Specifications

Device	Technology	Band	Frequency (MHz)	Maximum Antenna Gain (dBi)
RC7611, RC7611-1, RC7611D, RC7611D-1,	LTE	2	1850–1910	6
		4	1710–1755	6
		5	824–849	6
		12	699–716	6
		13	777–787	6
		14	788–798	6
		25	1850–1915	6
		26	814–849	6
		66	1710–1780	6
		71	663–698	6
RC7612, RC7612-1	LTE	Band 2	1850–1910	6
		Band 4	1710–1755	6
		Band 5	824–849	6
		Band 12	699–716	6
		Band 13	777–787	6
	UMTS	Band II	1850–1910	6
		Band IV	1710–1755	6
		Band V	824–849	6

4. The Semtech RC7611, RC7611-1, RC7611D, RC7611D-1, RC7612, and RC7612-1 may transmit simultaneously with other collocated radio transmitters within a host device, provided the following conditions are met:
 - Each collocated radio transmitter has been certified by FCC/IC for mobile application.

- At least 20 cm separation distance between the antennas of the collocated transmitters and the user's body must be maintained at all times.
- The radiated power of a collocated transmitter must not exceed the EIRP limit stipulated in [Table 9-2](#).

Table 9-2: Collocated Radio Transmitter Specifications

Device	Technology	Frequency (MHz)	EIRP Limit (dBm)
Collocated transmitters ^a	WLAN	2400–2500	25
		5150–5850	27
	WiMAX	2300–2400	25
		2500–2700	25
		3300–3800	25
	BT	2400–2500	15

a. Valid collocated transmitter combinations: WLAN+BT; WiMAX+BT.
(WLAN+WiMAX+BT is not permitted.)

5. A label must be affixed to the outside of the end product into which the Semtech RC7611, RC7611-1, RC7611D, RC7611D-1, RC7612, or RC7612-1 is incorporated, with a statement similar to the following:
 - **(RC7611/RC7611-1/RC7611D/RC7611D-1) This device contains FCC ID: N7NRC76B / IC: 2417C-RC76B**
 - **(RC7612/RC7612-1) This device contains FCC ID: N7NRC76C / IC: 2417C-RC76C**
6. A user manual with the end product must clearly indicate the operating requirements and conditions that must be observed to ensure compliance with current FCC/IC RF exposure guidelines.

The end product with an embedded RC7612, RC7611, or RC7611D may also need to pass the FCC Part 15 unintentional emission testing requirements and be properly authorized per FCC Part 15.

Note: If this module is intended for use in a portable device, you are responsible for separate approval to satisfy the SAR requirements of FCC Part 2.1093 and IC RSS-102.

9.3.1.1 Industry Canada Statement

This device complies with Industry Canada license-exempt RSS standard(s). Operation is subject to the following two conditions:

- (1) this device may not cause interference, and
- (2) this device must accept any interference, including interference that may cause undesired operation of the device.

This module is intended for OEM integrator. The OEM integrator is responsible for the compliance to all the rules that apply to the product into which this certified RF module is integrated. Additional testing and certification may be necessary when multiple modules are used.

This equipment complies with IC RSS-102 radiation exposure limits set forth for an uncontrolled environment. This equipment should be installed and operated with minimum distance 20 cm between the radiator and your body.

Le présent appareil est conforme aux CNR d'Industrie Canada applicables aux appareils radio exempts de licence. L'exploitation est autorisée aux deux conditions suivantes :

(1) l'appareil ne doit pas produire de brouillage, et

(2) l'utilisateur de l'appareil doit accepter tout brouillage radioélectrique subi, même si le brouillage est susceptible d'en compromettre le fonctionnement.

L'intégrateur OEM doit être conscient de ne pas fournir des informations à l'utilisateur final quant à la façon d'installer ou de supprimer ce module RF dans le manuel de l'utilisateur du produit final qui intègre ce module. Le manuel de l'utilisateur final doit inclure toutes les informations réglementaires requises et avertissements comme indiqué dans ce manuel.

Cet équipement est conforme aux limites d'exposition aux rayonnements IC établies pour un environnement non contrôlé. Cet équipement doit être installé et utilisé avec un minimum de 20 cm de distance entre la source de rayonnement et votre corps.

9.3.2 Japan Radio and Telecom Approval

The RC76xx Series modules have been granted Japan radio and telecom approvals with the approval numbers shown below.

- RC7630 and RC7630-1:

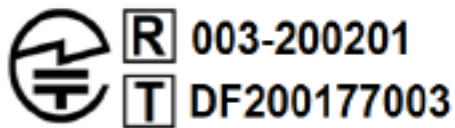

- RC7630J*:

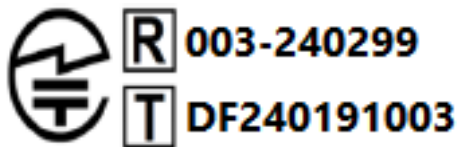

**Limited availability*

10: Pinout

The system interface of the Semtech RC76xx is through the LGA pattern on the bottom of the PCB.

Semtech RC76xx pins are divided into three functional categories:

- Core functions and associated pins — Cover all the mandatory features for M2M connectivity and will be available by default across all CF3 family of modules. These Core functions are always available and always at the same physical pin locations. A customer platform using only these functions and associated pins is guaranteed to be forward and/or backward compatible with the next generation of CF3 modules.
- Extension functions and associated pins — Bring additional capabilities to the customer. Whenever an Extension function is available on a module, it is always at the same pin location.
- Custom functions and associated pins — These are module-specific and make use of specific chipset functions and I/Os.

Warning: Custom features should be used with caution as there is no guarantee that the custom functions available on a given module will be available on other CF3 modules.

Pins marked as "Leave open" or "Reserved" should not be used or connected.

10.1 Pin Configuration

Figure 10-1 illustrates the pin configuration of the RC76xx series module.



Figure 10-1: Pin Configuration (Top View, Through Module)

10.2 Pin Description

Table 10-1 on page 133 lists detailed information for the LGA pins.

Note: Some pin numbers (112, 126, 127, 137, 138, 235) do not appear in this table because there are no corresponding pads on the module's PCB.

Table 10-1: Pin Definitions

Pin	Signal Name	Group	I/O ^a	Voltage	PU/ PD in active status ^b	Active	If Unused	Function	Type
1	I2C1_CLK	I2C	I/O	1.8V	PU		Leave open	I ² C clock	Core
2	UART1_RI ^{c,d}	UART1	O	1.8V		L	Leave open	UART1 Ring indicator	Core
<i>Note: Do not install external pull-up on this pin, otherwise the module will not boot.</i>									
3	UART1_RTS ^c	UART1	I	1.8V	PD	L	Leave open	UART1 Request to send	Core
4	UART1_CTS ^c	UART1	O	1.8V		L	Leave open	UART1 Clear to send	Core
5	UART1_TX ^c	UART1	I	1.8V	PD	L	Leave open	UART1 Transmit data	Core
6	UART1_RX ^c	UART1	O	1.8V			Leave open	UART1 Receive data	Core
7	UART1_DTR ^{c,e,l}	UART1	I	1.8V	PD	L	Leave open	UART1 Data terminal ready	Core
8	UART1_DCD ^{c,d}	UART1	O	1.8V		L	Leave open	UART1 Data carrier detect	Core
<i>Note: Do not install external pull-up on this pin, otherwise the module will not boot.</i>									
9	UART1_DSR ^{c,d}	UART1	O	1.8V		L	Leave open	UART1 Data set ready	Core
<i>Note: Do not install external pull-up on this pin, otherwise the module will not boot.</i>									
10	GPIO2 ^e	GPIO	I/O	1.8V	PD		Leave open	General purpose I/O	Core
11	RESET_IN_N	Control signal	I	1.8V	PU	L	Leave open	Input reset signal	Core
12	USB_D-	USB	I/O				Leave open	USB Data negative	Core
13	USB_D+	USB	I/O				Leave open	USB Data positive	Core
14	Reserved	No Connection					See footnote ^f		Extension
15	Reserved	No Connection					See footnote ^f		Extension

Table 10-1: Pin Definitions (Continued)

Pin	Signal Name	Group	I/O ^a	Voltage	PU/ PD in active status ^b	Active	If Unused	Function	Type
16	USB_VBUS	USB	I	5V or VBAT_BB			Optional connection (If USB interface is required then connect to USB_VBUS or, if unavailable, VBAT_BB; otherwise, leave open.)	USB power supply	Core
17– 20	Reserved	No Connection					See footnote ^f		Extension
21	Reserved	No Connection					See footnote ^f		Extension
22	SYS_CLK	Clock	O	1.8V			Leave open	19.2 MHz digital clock output	Extension
23	SLEEP_CLK	Clock	O	1.8V			Leave open	32.768 kHz digital clock output	Extension
24	ADC1	ADC	AI	0.1V - 1.7V			Leave open	Analog to digital conversion	Core
25	ADC0	ADC	AI	0.1V - 1.7V			Leave open	Analog to digital conversion	Core
26	UIM1_VCC	UIM1	Power Output	1.8V / 2.85V			Mandatory connection	UIM1 Power supply	Core
27	UIM1_CLK	UIM1	O	1.8V / 2.85V			Mandatory connection	UIM1 Clock	Core
28	UIM1_DATA	UIM1	I/O	1.8V / 2.85V			Mandatory connection	UIM1 Data	Core
29	UIM1_RESET_N	UIM1	O	1.8V / 2.85V		L	Mandatory connection	UIM1 Reset	Core
30	GND	Ground	0V	0V			Mandatory connection	Diversity antenna ground	Extension
31	RF_DIV	RF	AI				Mandatory connection	Diversity antenna	Extension
32	GND	Ground	0V	0V			Mandatory connection	Diversity antenna ground	Extension
33	PCM_OUT	PCM	O	1.8V			Leave open	PCM data out	Core
	I2S_OUT	I2S	O	1.8V			Leave open	I2S data out	
34	PCM_IN	PCM	I	1.8V	PD		Leave open	PCM data in	Core
	I2S_IN	I2S	I	1.8V	PD		Leave open	I2S data in	
35	PCM_SYNC	PCM	O	1.8V			Leave open	PCM sync	Core
	I2S_WS	I2S	O	1.8V			Leave open	I2S word select	

Table 10-1: Pin Definitions (Continued)

Pin	Signal Name	Group	I/O ^a	Voltage	PU/ PD in active status ^b	Active	If Unused	Function	Type
36	PCM_CLK	PCM	O	1.8V			Leave open	PCM clock	Core
	I2S_CLK	I2S	O	1.8V			Leave open	I2S clock	
37	GND	Ground	0V	0V			Mandatory connection	GNSS antenna ground	Core
38	RF_GNSS	RF	AI				Leave open	RF GNSS input	Extension
39	GND	Ground	0V	0V			Mandatory connection	GNSS antenna ground	Core
40	GPIO7	GPIO	I/O	1.8V	PD		Leave open	General purpose I/O	Core
41	GPIO8	GPIO	I/O	1.8V	PD		Leave open	General purpose I/O	Core
42	DR_SYNC	GPS	O	1.8V			Leave open	GPS dead reckoning sync	Extension
43	EXT_GPS_LNA_EN	GPS	O	1.8V		H	Leave open	External GNSS LNA enable	Extension
44	GPIO13	GPIO	I/O	1.8V	PD		Leave open	General purpose I/O	Extension
45	VGPIO	Voltage reference	Power Output	1.8V			Leave open	GPIO voltage output	Core
46	Ext_SIM_switch ^g	O	I	1.8V			Leave open	External SIM switch	Core
	GPIO6	GPIO	I/O	1.8V	PD		Leave open	General purpose I/O	Core
	RESET_OUT_N	Control Signal	O	1.8V			Leave open	Reset output signal	Core
47	TP1 (Boot pin)	Control Signal	I	1.8V		L	Mandatory test point	Test point 1 0 — Download mode Open — Normal mode	Extension
48	GND	Ground	0V	0V			Mandatory connection	Main antenna ground	Core
49	RF_MAIN	RF	AI, AO				Mandatory connection	Main RF antenna	Core
50	GND	Ground	0V	0V			Mandatory connection	Main antenna ground	Core
51	SPI1_MRDY	SPI1	O	1.8V			Leave open	SPI Master Ready	Core
52	SPI1_MISO	SPI1	I	1.8V	PD		Leave open	SPI Master Input/ Slave Output (output from slave)	Core
53	SPI1_CLK	SPI1	O	1.8V			Leave open	SPI serial clock (output from Master)	Core

Table 10-1: Pin Definitions (Continued)

Pin	Signal Name	Group	I/O ^a	Voltage	PU/ PD in active status ^b	Active	If Unused	Function	Type
54	SPI1_MOSI	SPI1	O	1.8V			Leave open	SPI Master Output/ Slave Input (output from master)	Core
55	Reserved ^j	No Connection					See footnote ^f		Core
	UIM2_VCC ^k	UIM2	Power Output	1.8V / 2.85V			Leave open	UIM1 Power	
56	Reserved ^j	No Connection					See footnote ^f		Core
	UIM2_DATA ^k	UIM2	I/O	1.8V / 2.85V			Leave	UIM1	
57	Reserved ^j	No Connection					See footnote ^f		Core
	UIM2_RESET_N ^k	UIM2	O	1.8V / 2.85V			Leave	UIM1	
58	Reserved ^j	No Connection					See footnote ^f		Core
	UIM2_CLK ^k	UIM2	O	1.8V / 2.85V			Leave open	UIM1 Clock	
59	POWER_ON_N	Control Signal	I	0.8V	PU	L	Mandatory connection	Power On control signal	Core
60	TX_ON	Indication	O	1.8V		H	Leave open	Tx activity indicator	Extension
61	VBAT_RF	Power	Power Input	3.2V (min) 3.7V (typ) 4.3V (max)			Mandatory connection	RF power supply (see Power Supply Ratings)	Core
62	VBAT_RF	Power	Power Input	3.2V (min) 3.7V (typ) 4.3V (max)			Mandatory connection	RF power supply (see Power Supply Ratings)	Core
63	VBAT_BB	Power	Power Input	3.2V (min) 3.7V (typ) 4.3V (max)			Mandatory connection	Baseband power supply (see Power Supply Ratings)	Core
64	UIM1_SIMA_DET ^e	UIM1	I	1.8V	PU	H	Mandatory connection	Detect UIM1 insertion/removal. (Pin must be open to detect the UIM, or grounded if no UIM is present.)	Core
65	UIM1_SIMB_DET ^e	UIM1	I	1.8V	PU	H	Leave open	Detect UIM1_SIMB insertion / removal / General purpose I/ O	Extension
	GPIO4 ^f	GPIO	I/O	1.8V	PD		Leave open	General purpose I/ O	Extension
66	I2C1_Data	I2C	I/O	1.8V	PU		Leave open	I ² C data	Core

Table 10-1: Pin Definitions (Continued)

Pin	Signal Name	Group	I/O ^a	Voltage	PU/ PD in active status ^b	Active	If Unused	Function	Type
67–70	GND	Ground	0V	0V			Mandatory connection	Ground	Core
71–90	Reserved	No Connection					See footnote ^f		Reserved
91	Reserved	No Connection					See footnote ^f		Reserved
92	Reserved	No Connection					See footnote ^f		Reserved
93	Reserved	No Connection					See footnote ^f		Reserved
94	Reserved	No Connection					See footnote ^f		Reserved
95	Reserved	No Connection					See footnote ^f		Reserved
96	UART2_TX ^c	UART2	I	1.8V	PD	L	Leave open	UART2 Transmit data	Extension
97	UART2_RX ^c	UART2	O	1.8V	PD	L	Leave open	UART2 Receive data	Extension
98	UART2_RTS ^c	UART2	I	1.8V	PD		Leave open	UART2 Request To Send	Extension
99	UART2_CTS ^c	UART2	O	1.8V			Leave open	UART2 Clear To Send	Extension
100	Reserved	No Connection					See footnote ^f		Reserved
101	GPIO35	GPIO	I/O	1.8V	PD		Leave open	General purpose I/O	Extension
102	Reserved	No Connection					See footnote ^f		Reserved
103	Reserved	No Connection					See footnote ^f		Reserved
104	GPIO32	GPIO	I/O	1.8V	PD		Leave open	General purpose I/O	Extension
105	GPIO33	GPIO	I/O	1.8V	PD		Leave open	General purpose I/O	Extension
106	WWAN_LED_N	Indication	O	VBAT_BB ^g		L	Leave open	LED driver control	Extension
107	Reserved	No Connection					See footnote ^f		Reserved
108	Reserved	No Connection					See footnote ^f		Reserved
109	GPIO42 ^e	GPIO	I/O	1.8V	PD		Leave open	General purpose I/O	Extension

Table 10-1: Pin Definitions (Continued)

Pin	Signal Name	Group	I/O ^a	Voltage	PU/ PD in active status ^b	Active	If Unused	Function	Type
110	WAKE_ON_WWAN	Indication	O	1.8V		H	Leave open	Driven high to wake the host when specific events occur.	Extension
111	GND	Ground	0V	0V			Mandatory connection	Diversity antenna ground	Core
113	GND	Ground	0V	0V			Mandatory connection	Diversity antenna ground	Core
114– 124	Reserved	No Connection					See footnote ^f		Reserved
125	GND	Ground	0V	0V			Mandatory connection	GNSS antenna ground	Core
128	GND	Ground	0V	0V			Mandatory connection	GNSS antenna ground	Core
129– 135	Reserved	No Connection					See footnote ^f		Reserved
136	GND	Ground	0V	0V			Mandatory connection	Main antenna ground	Core
139	GND	Ground	0V	0V			Mandatory connection	Main antenna ground	Core
140– 146	Reserved	No Connection					See footnote ^f		Reserved
147	GPIO21 ^e	GPIO	I/O	1.8V	PD		Leave open	General purpose I/O	Core
148	GPIO22	GPIO	I/O	1.8V	PD		Leave open	General purpose I/O	Core
149	GPIO23	GPIO	I/O	1.8V	PD		Leave open	General purpose I/O	Core
150	GPIO24	GPIO	I/O	1.8V	PD		Leave open	General purpose I/O	Core
151	W_DISABLE_N	Control Signal	I	1.8V	PU	L	Leave open	Wireless disable (main RF radio)	Core
152	SAFE_PWR_REMOVE	Indication	O	1.8V		H	Leave open	Indicate to host that Main DC power can be removed	Extension
153	ANT_CNTLO	Antenna control	O	1.8V			Leave open	Antenna control	Extension
	GPIO28 ^h	GPIO	I/O	1.8V	PD		Leave open	General purpose I/O	Extension
154	ANT_CNTL1	Antenna control	O	1.8V			Leave open	Antenna control	Extension
	GPIO29 ^h	GPIO	I/O	1.8V	PD		Leave open	General purpose I/O	Extension

Table 10-1: Pin Definitions (Continued)

Pin	Signal Name	Group	I/O ^a	Voltage	PU/ PD in active status ^b	Active	If Unused	Function	Type
155	ANT_CNTL2	Antenna control	O	1.8V			Leave open	Antenna control	Extension
	GPIO30 ^h	GPIO	I/O	1.8V	PD		Leave open	General purpose I/O	Extension
156	ANT_CNTL3	Antenna control	O	1.8V			Leave open	Antenna control	Extension
	GPIO31 ^h	GPIO	I/O	1.8V	PD		Leave open	General purpose I/O	Extension
157	VBAT_RF	Power	Power Input	3.2V (min) 3.7V (typ) 4.3V (max)			Optional connection	RF power supply (see Power Supply Ratings)	Core
158	VBAT_BB	Power	Power Input	3.2V (min) 3.7V (typ) 4.3V (max)			Optional connection	Baseband power supply (see Power Supply Ratings)	Core
159	GPIO25	GPIO	I/O	1.8V	PD		Leave open	General purpose I/O	Core
160	Reserved	No Connection					See footnote ^f		Reserved
161	Reserved	No Connection					See footnote ^f		Reserved
162	Reserved	No Connection					See footnote ^f		Reserved
163	Reserved	No Connection					See footnote ^f		Reserved
164	Reserved	No Connection					See footnote ^f		Reserved
165	Reserved	No Connection					See footnote ^f		Reserved
166	Reserved	No Connection					See footnote ^f		Reserved
167–234	GND	Ground	0V	0V			Mandatory connection	Ground	Core
236	J1 ⁱ			1.8V		L	Mandatory test point	Test point	Extension
237	J2 ⁱ			1.8V			Mandatory test point	Test point	Extension
238	J3 ⁱ			1.8V			Mandatory test point	Test point	Extension
239	J4 ⁱ			1.8V			Mandatory test point	Test point	Extension
240	J5 ⁱ			1.8V		L	Mandatory test point	Test point	Extension

Table 10-1: Pin Definitions (Continued)

Pin	Signal Name	Group	I/O ^a	Voltage	PU/ PD in active status ^b	Active	If Unused	Function	Type
241	J6 ⁱ			1.8V			Mandatory test point	Test point	Extension
242	J7 ⁱ			1.8V			Mandatory test point	Test point	Extension
243	J8 ⁱ			1.8V			Mandatory test point	Test point	Extension
244	J9 ⁱ			1.8V			Mandatory test point	Test point	Extension

- Signal direction with respect to the module. Examples: PCM_OUT (pin 33) is an output from the module to the host; PCM_IN (pin 34) is an input to the module from the host.
- NP—No Pull; PD—Pull Down; PU—Pull Up (in default/active normal mode)
- (UART signals only) Signals are named with respect to the host device. For example, UART1_RX is the signal used by the host to receive data from the module.
- Do not install external pull-up on this pin, otherwise the module will not boot.
- Pin is 'wakeable'. Can be used to trigger the module to wake up from Sleep mode. See [Wakeup Interrupt \(Sleep State\)](#) for details.
- Pins are connected internally, but are reserved for future use. Leave them unconnected to ensure compatibility with other Semtech CF3 modules.
- Refer to [GPIO6](#) for functional details.
- This pin is available for use when configured using **AT+WIOCFG**.
- Accessibility restricted to soldered-down modules. Not available for socket-mounted modules.
- For RC7611, RC7611D, RC7620, RC7630, and RC7630J* (* Limited availability).
- Limited Availability for RC7612, RC7612-1.
- The pin (UART1_DTR) will be floating when KSLEEP=0 and will pull-up when KSLEEP=1 or 2. For details on KSLEEP, see the RC76xx AT command guide.

Table 10-2: RF Pin Information

Signal name	Pin #	Description
RF_DIV	31	Diversity input
RF_GNSS ^a	38	RF GNSS input
RF_MAIN	49	Main RF port (input/output)

- Support is SKU-dependent.

Table 10-3: Supply Pin Information

Signal name	Pin #	Description
VBAT_RF	61, 62, 157	RF power supply
VBAT_BB	63, 158	Baseband power supply
USB_VBUS	16	Connected to USB_VBUS (5V) or (if unavailable) VBAT_BB

11: Customization

Subject to commercial terms, Semtech can supply custom-configured modems to facilitate a carrier's network and performance requirements. Semtech also offers a standard configuration for each country.

Custom configurations are entered into a selector spreadsheet that Sierra supplies. A unique part number is assigned to each custom configuration to facilitate customer ordering.

Table 11-1: Customizable Features

Name	Description	Default
Display of IMSI	Display of International Mobile Subscriber Identity via AT+CIMI command	Display enabled
UART baud rate	Default UART speed	115200 bps
UART enabled	Defines whether UART port is enabled by default or not	UART enabled

12: Testing

12.1 Certification Testing

Note: Typically, certification testing of your device with the integrated module is required one time only.

The Semtech RC76xx module has been certified as described in [Compliance Acceptance and Certification](#).

When you produce a host device with a Semtech Semtech embedded module, you must obtain certifications for the final product from appropriate regulatory bodies in the jurisdictions where it will be distributed.

The following are *some* of the regulatory bodies from which you may require certification — it is your responsibility to make sure that you obtain all necessary certifications for your product from these or other groups:

- FCC (Federal Communications Commission — www.fcc.gov)
- GCF (Global Certification Forum — www.globalcertificationforum.org) outside of North America
- PTCRB (PCS Type Certification Review Board — www.ptcrb.com) in North America

12.2 Production Testing

Note: Production testing typically continues for the life of the product.

Production testing ensures that, for each assembled device, the module is installed correctly (I/O signals are passed between the host and module), and the antenna is connected and performing to specifications (RF tests).

Typical items to test include:

- Host connectivity
- Baseband (host/module connectors)
- RF assembly (Tx and/or Rx, as appropriate)
- Network availability
- Host/device configuration issues

*Note: The number and types of tests to perform are **your** decision — the tests listed in this section are guidelines only. Make sure that the tests you perform exercise functionality to the degree that **your** situation requires.*

Use an appropriate test station and use AT commands to control the integrated module.

Note: Your test location must be protected from ESD to avoid interference with the module and antenna(s), assuming that your test computer is in a disassembled state.

Also, consider using an RF shielding box — local government regulations may prohibit unauthorized transmissions.

Note: The tests described in this chapter are done using a Linux O/S (e.g. Ubuntu 12.04).

12.3 Functional Production Test

This section presents a suggested procedure for performing a basic manual functional test on a laboratory bench using an Semtech RC76xx module and a hardware development kit. When you have become familiar with the testing method, use it to develop your own automated production testing procedures.

12.3.1 Suggested Production Tests

Consider the following tests when you design your production test procedures for devices with the module installed.

- Visual check of the module’s connectors and RF assemblies
- Module is operational
- USB connection is functional
- LED is functional
- Power on/off
- Firmware revision check
- Rx tests on main and auxiliary paths
- Tx test

12.3.2 Production Test Procedure

The following is a suggested test plan — you must decide which tests are appropriate for your product. You may wish to add additional tests that more fully exercise the capabilities of your product.

Using an appropriate test station, and referring to the appropriate AT command references:

1. Visually inspect the module for obvious defects (such as tainted or damaged shields) before installing it in the test station.
2. Ensure that the module is powered off (no voltage on VBAT_BB/VBAT_RF) before beginning your tests.
3. Determine whether any USB devices are currently connected to the computer:
 - a. Open a shell window and enter the command **ls /dev/tty/USB***.
 - b. Record the `ttyUSBn` values that are returned; these are the currently connected USB devices. If the command returns “no such file or directory”, there are no devices currently connected.
4. Provide power to the module (voltage on VBAT_BB/VBAT_RF).
5. Test POWER_ON_N — Turn on the module by driving POWER_ON_N low, as shown in [Figure 4-2](#).
6. Test USB functionality — Check for USB enumeration.

Enter the command **ls /dev/tty/USB*** and then record and compare the results with those from [Step 3](#). If there are any new `ttyUSBn` devices, then the modem has enumerated successfully. (The AT port is usually the *last* new device.)
7. Make sure your modem is connected and running, and then establish contact with the module:

Use a terminal emulation/communications program such as minicom to connect over the device handle for AT commands (see listings in [Step 6](#)):

Note: If the command “minicom” is not found, then use a different program, or download minicom and repeat this step. See [Downloading and Configuring minicom for Linux Systems](#) on page 144 for details.

- a. Start minicom:
 - First use of the modem: From the command line, type `minicom -s`. (The ‘-s’ switch shows the configuration menu.)

- Subsequent uses: From the command line, type `minicom`. (The `-s` switch is assumed.) The `minicom` configuration details appear and the message `OK` appears when the connection is established.

```

Telnet 00.0.00.00
Welcome to minicom 2.2
OPTIONS: I18n
Compiled on Apr 27 2007, 15:50:20.
Port /dev/ttyUSB2

Press CTRL-A Z for help on special keys
AT S7=45 S0=0 L1 U1 X4 &c1 E1 Q0
OK
CTRL-A Z for help !115200 8N1 ! NOR ! Minicom 2.2 ! UT102 !Offline

```

8. Display the firmware version using **ATI**.
9. Unlock the extended AT command set with **AT!ENTERCND=<password>**.

*Note: Use **AT!ENTERCND?** to check command syntax which is SKU-dependent.*

10. Test the LED — Visually confirm that the LED turns on and off using:
 - AT!LEDTEST=0,1** (LED on)
 - AT!LEDTEST=0,0** (LED off)
11. Put the module in diagnostic/factory test mode using **AT!DAFTMACT**:
12. Communicate with the SIM using **AT+CPIN** or **AT+CIMI**.
13. Test RF transmission, if desired.
 - For LTE, see [LTE RF Transmission Path Test](#) on page 147.
 - For UMTS, see [UMTS \(WCDMA/GSM\) RF Transmission Path Test](#) on page 145
14. Test RF reception, if desired.
 - For LTE, see [LTE RF Receive Path Test](#) on page 153.
 - For UMTS, see [UMTS \(WCDMA/GSM\) RF Receive Path Test](#) on page 150.
15. Test standalone GNSS functionality. See [GNSS RF Receive Path Test](#) on page 155.
16. Remove power from the module.

12.3.2.1 Downloading and Configuring minicom for Linux Systems

Note: This procedure is for Ubuntu systems. If you are using a different Linux distribution, use the appropriate commands for your system to download minicom.

To download and configure minicom in a Ubuntu system:

Note: To install minicom, you must have root access, or be included in the `sudoers` list.

1. Download and install minicom by entering **sudo apt-get install minicom**.
2. When prompted, enter your user password to begin the download and installation. When minicom is installed, the shell prompt appears.
3. Configure minicom to communicate with your modem. Start minicom with command **minicom -s**.
4. Use the down-arrow key to select the **Serial port setup** option.

5. Refer to [Step 6](#) on page 143 to identify the device file handle (/dev/ttyUSBn) used for AT commands.
6. Indicate the file handle to use for AT commands— Enter A and then replace the serial device string with the AT file handle.
7. Press **Enter** twice.
8. Use the down-arrow key to select **Save setup as dfi**.
9. Select **Exit**.

12.4 UMTS (WCDMA/GSM) RF Transmission Path Test

Important: *As of the publication date of this document, the test procedure described is to be considered preliminary, pending implementation of some commands in a future firmware upgrade.*

Note: This procedure is performed in [Step 13](#) of the [Production Test Procedure](#) on page 143

The suggested test procedure that follows uses the parameters in the following tables.

Table 12-1: Test Settings—RC7620 UMTS Transmission Path

Band		Frequency (MHz)	Band ID	Tx Channel ^a
2100 MHz	B1	1950.0	9	9750
900 MHz	B8	897.6	29	2788

a. Channel values shown are at the center of the corresponding bands.

Table 12-2: Test Settings—RC7620 2G Transmission Path

Band		Frequency (MHz)	Band ID	Tx Channel ^a
900 MHz	E-GSM 900	897.4	10	37
1800 MHz	DCS 1800	1747.8	11	700

a. Channel values shown are at the center of the corresponding bands

Table 12-3: Test Settings—RC7612 UMTS Transmission Path

Band		Frequency (MHz)	Band ID	Tx Channel
1900 MHz	B2	1880	16	9400
AWS-1	B4	1732.6	28	1413
850 MHz	B5	836.6	22	4183

Note: This procedure describes steps using the "Power Meter: Gigatronics 8651a (with option 12 and Power Sensor 80701A).

To test the DUT's transmitter path:

1. Set up the power meter:

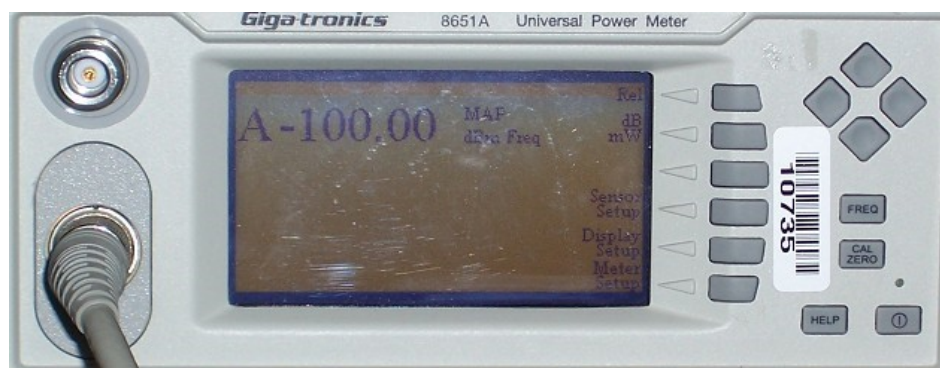

- a. Make sure the meter has been given sufficient time to warm up, if necessary, to enable it to take accurate measurements.
 - b. Zero-calibrate the meter.
 - c. Enable MAP mode.
2. Prepare the DUT using the following AT commands:
 - a. **AT!ENTERCND="<password>"** (Unlock extended AT command set.)
 - b. **AT!DAFTMACT** (Enter test mode.)
 - c. **AT!DASBAND=<bandValue>** (Set frequency band, e.g. 34 for LTE B1.)
 - d. **AT!DALSTXBW=3** (Set Tx bandwidth to 10 MHz.)
 - e. **AT!DALSRXBW=3** (Set Rx bandwidth to 10 MHz.)
 - f. **AT!DASCHAN=<channel>** (Set modem channel, e.g. 18300 for LTE B1.)
 - g. **AT!DALSTXMOD=0** (Set Tx modulation type to QPSK.)
 - h. **AT!DALSWAVEFORM=1, 12, 0, 19** (Set the Tx waveform characteristics. Make sure to set the correct resource block allocation (2nd parameter) appropriately. For example, 12 is used to produce max power—refer to 3GPP 36.521 table for Maximum Power Reduction (MPR) for Power Class 3 for more information.)
 - i. **AT!DALSNSVAL=1** (Set the LTE NS (Net Sig) value.)
 - j. **AT!DASTXON** (Turn on the transmitter. Note that the transmitter will put out the last power level that was programmed.)
 - k. **AT!DALSTXPWR=1, 10** (Begin transmitting at requested power level.)
 - l. Take the measurement.
 - m. Repeat [Step k](#) with different power levels if desired.
 - n. **AT!DALSTXPWR=0, 0** (Reduce Tx power to 0, so next time transmitter is turned on, it will come on with 0 dBm power.)
 - o. **AT!DASTXOFF** (Turn off the transmitter.)
 3. Test limits—Run ten or more good DUTs through this test procedure to obtain a nominal output power value.
 - Apply a tolerance of ± 5 to 6 dB to each measurement (assuming a good setup design).
 - Monitor these limits during mass-production ramp-up to determine if further adjustments are needed.

Note: The module has a nominal output power of +23 dBm ±1 dB in LTE mode. However, the value measured by the power meter is significantly influenced (beyond the stated ±1 dB output power tolerance) by the test setup (host RF cabling loss, antenna efficiency and pattern, test antenna efficiency and pattern, and choice of shield box). When doing the same test over the air in an RF chamber, values are likely to be significantly lower.

12.5 LTE RF Transmission Path Test

Important: *As of the publication date of this document, the test procedure described is to be considered preliminary, pending implementation of some commands in a future firmware upgrade.*

Note: This procedure segment is performed in [Step 13](#) of the [Production Test Procedure](#) on page 143.

The suggested test procedure that follows uses the parameters in the following tables.

Table 12-4: Test Settings — RC7611, RC7611D, RC7612^a LTE Transmission Path

Band		Frequency (MHz)	Band ID	Channel ^b
1900 MHz	B2	1880.0	43	18900
1700 MHz	B4	1732.4	42	20175
850 MHz	B5	836.5	45	20525
700 MHz	B12	707.5	50	23095
700 MHz	B13	782.0	36	23230
700 MHz	B14	793.0	51	23330
1900 MHz	B25	1882.5	61	26365
850 MHz	B26	831.5	62	26865
1700 MHz	B66	1745.0	83	132322
600 MHz	B71	680.5	97	133297

- a. Limited availability.
- b. Channel value used by the `!DASCHAN` command (`!DASCHAN` uses uplink (Tx) channel at the center of the corresponding band, for both Tx and Rx testing)

Table 12-5: Test Settings—RC7620 LTE Transmission Path

Band		Frequency (MHz)	Band ID	Channel ^a
2100 MHz	B1	1950.0	34	18300
1800 MHz	B3	1747.5	44	19575
2600 MHz	B7	2535.0	35	21100

Table 12-5: Test Settings—RC7620 LTE Transmission Path (Continued)

Band		Frequency (MHz)	Band ID	Channel ^a
900 MHz	B8	897.5	47	21625
800 MHz	B20	847.0	56	24300
700 MHz	B28	725.5	64	27435

- a. Channel value used by the !DASCHAN command (!DASCHAN uses uplink (Tx) channel at the center of the corresponding band, for both Tx and Rx testing.)

Table 12-6: Test Settings—RC7630 LTE Transmission Path

Band		Frequency (MHz)	Band ID	Channel ^a
2100 MHz	B1	1950.0	34	18300
1800 MHz	B3	1747.5	44	19575
850 MHz	B5	836.5	45	20525
2600 MHz	B7	2535	35	21100
900 MHz	B8	897.5	47	21625
800 MHz	B18	822.5	54	23925
800 MHz	B19	837.5	55	24075
1500 MHz	B21	1455.5	57	24525

- a. Channel value used by the !DASCHAN command (!DASCHAN uses uplink (Tx) channel at the center of the corresponding band, for both Tx and Rx testing.)

Table 12-7: Test Settings—RC7630J^a LTE Transmission Path

Band		Frequency (MHz)	Band ID	Channel ^b
2100 MHz	B1	1950.0	34	18300
1800 MHz	B3	1747.5	44	19575
850 MHz	B5	836.5	45	20525
800 MHz	B18	822.5	54	23925
800 MHz	B19	837.5	55	24075

- a. Limited availability.
b. Channel value used by the !DASCHAN command (!DASCHAN uses uplink (Tx) channel at the center of the corresponding band, for both Tx and Rx testing.)

To test the DUT's transmitter path:

Note: This procedure describes steps using the 'Power Meter: Gigatronics 8651A' (with Option 12 and Power Sensor 80701A).

1. Set up the power meter:

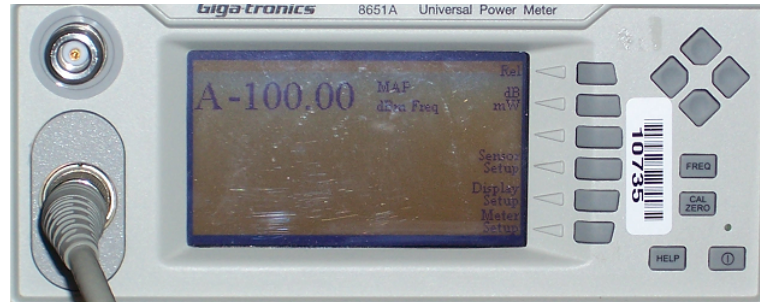

- a. Make sure the meter has been given sufficient time to warm up, if necessary, to enable it to take accurate measurements.
 - b. Zero-calibrate the meter.
 - c. Enable MAP mode.
2. Prepare the DUT using the following AT commands (adjusting the band, channel, bandwidth, modulation, RB allocation, NS, and power level as necessary):
 - a. **AT!ENTERCND="<password>"** (Unlock extended AT command set.)
 - b. **AT!DAFTMACT** (Enter test mode.)
 - c. **AT!DASBAND=<bandValue>** (Set frequency band (e.g. 34 for LTE B1.))
See table [Table 12-4](#) on page 147 for appropriate <bandValue> values.
 - d. **AT!DALSTXBW=3** (Set Tx bandwidth to 10 MHz.)
 - e. **AT!DALSRXBW=3** (Set Rx bandwidth to 10 MHz.)
 - f. **AT!DASCHAN=<channel>** (Set modem channel (e.g. 18300 for LTE B1.))
See tables [Table 12-4](#) on page 147 for appropriate <channel> values.
 - g. **AT!DALSTXMOD=0** (Set Tx modulation type to QPSK.)
 - h. **AT!DALSWAVEFORM=1, 12, 0, 19** (Set the Tx waveform characteristics. Make sure to set the correct resource block allocation (2nd parameter) appropriately. For example, 12 is used to produce max power—refer to 3GPP 36.521 table for Maximum Power Reduction (MPR) for Power Class 3 for more information.)
 - i. **AT!DALSNSVAL=1** (Set the LTE NS (Net Sig) value.)
 - j. **AT!DASTXON** (Turn on the transmitter. Note that the transmitter will put out the last power level that was programmed.)
 - k. **AT!DALSTXPWR=1, 10** (Begin transmitting at requested power level.)
 - l. Take the measurement.
 - m. Repeat [Step k](#) with different power levels if desired.
 - n. **AT!DALSTXPWR=0, 0** (Reduce Tx power to 0, so next time transmitter is turned on, it will come on with 0 dBm power.)
 - o. **AT!DASTXOFF** (Turn off the transmitter.)

3. Test limits—Run ten or more good DUTs through this test procedure to obtain a nominal output power value.
 - Apply a tolerance of ± 5 to 6 dB to each measurement (assuming a good setup design).
 - Monitor these limits during mass-production ramp-up to determine if further adjustments are needed.

Note: The module has a nominal output power of +23 dBm ± 1 dB in LTE mode. However, the value measured by the power meter is significantly influenced (beyond the stated ± 1 dB output power tolerance) by the test setup (host RF cabling loss, antenna efficiency and pattern, test antenna efficiency and pattern, and choice of shield box).

Note: When doing the same test over the air in an RF chamber, values are likely to be significantly lower.

12.6 UMTS (WCDMA/GSM) RF Receive Path Test

Note: This procedure segment is performed in [Step 14](#) of the [Production Test Procedure](#) on page 143.

The suggested test procedure that follows uses the parameters in the following tables.

Table 12-8: Test Settings—RC7620 UMTS Receive Path

Band		Frequency ^a (MHz)	Band ID	Rx Channel ^b
2100 MHz	B1	2141.2	9	10700
900 MHz	B8	943.8	29	3013

- a. Receive frequencies shown are 1.2 MHz offset from center.
- b. Channel values shown are at the center of the corresponding bands.

Table 12-9: Test Settings—RC7620 2G Receive Path

Band		Frequency ^a (MHz)	Band ID	Rx Channel ^b
900 MHz	E-GSM 900	942.467	10	37
1800 MHz	DCS 1800	1842.867	11	700

- a. Receive frequencies shown are 67 KHz offset from center.
- b. Channel values shown are at the center of the corresponding bands.

Table 12-10: Test Settings—RC7612 UMTS Receive Path

Band		Frequency ^a (MHz)	Band ID	Rx Channel ^b
1900MHz	B2	1960	16	9800
AWS-1	B4	2132.6	28	1638
850MHz	B5	881.6	22	4408

- a. Receive frequencies shown are 67 KHz offset from center.
- b. Channel values shown are at the center of the corresponding bands.

To test the DUT's receive path:

Note: This procedure describes steps using the Agilent 8648C signal generator—the Rohde & Schwarz SML03 is shown for reference only.

1. Set up the signal generator:

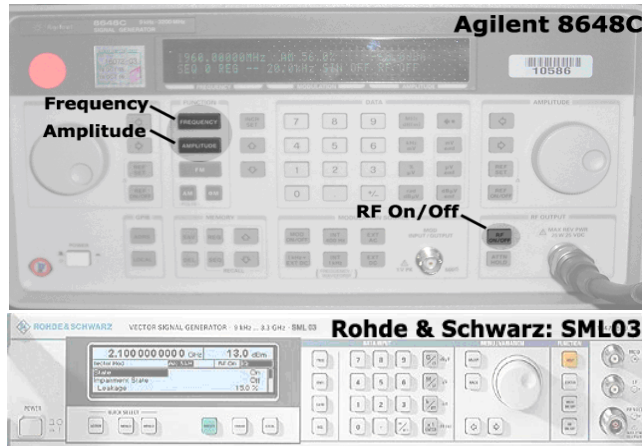

-
- a. Set the amplitude to:
 - -80 dBm (WCDMA mode)
 - -60 dBm (GSM mode)
 - b. Set the frequency for the band being tested. See [Table 12-8](#) and [Table 12-9](#) for frequency values.
2. Set up the DUT:
 - a. **AT!ENTERCND="<password>"** (Unlock extended AT command set.)
 - b. **AT!DAFTMACT** (Put modem into factory test mode.)
 - c. **AT!DASBAND=<band>** (Set frequency band.)
See [Table 12-8](#) and [Table 12-9](#) for <band> values
 - d. **AT!DASCHAN=<channel>** (Set modem channel)
• See [Table 12-8](#) and [Table 12-9](#) for <channel> values
 - e. **AT!DASLNAGAIN=0** (Set the LNA to maximum gain.)
 - f. **AT!DAWGAVGAGC=9400,0** (WCDMA mode: For PCS1900, channel 9400 as an example.)
 - g. GSM mode:
 - i. **AT!DAGSRXBURST=0** (Set to receive bursted mode.)
 - ii. **AT!DAGAVGRSSI=190,0** (For channel 190, for example)
 3. Test limits — Run ten or more good DUTs through this test procedure to obtain a nominal received power value.
 - Apply a tolerance of ± 5 to 6 dB to each measurement (assuming a good setup design).
 - Make sure the measurement is made at a high enough level that it is not influenced by DUT-generated and ambient noise.
 - The Signal Generator power level can be adjusted and new limits found if the radiated test needs greater signal strength.
 - Monitor these limits during mass-production ramp-up to determine if further adjustments are needed.

Note: The value measured from the DUT is significantly influenced by the test setup and DUT design (host RF cabling loss, antenna efficiency and pattern, test antenna efficiency and pattern, and choice of shield box).

4. Test diversity paths:
 - a. Set up the signal generator as in [Step a](#).
 - b. Set up the DUT:
 - i. **AT!ENTERCND="<password>"** Unlock extended AT command set.)
 - ii. **AT!DAFTMACT** Put modem into factory test mode.)
 - iii. **AT!DASBAND=<band>** (Set frequency band.)
 - See [Table 12-8](#) and [Table 12-9](#) for <band> values
 - iv. **AT!DAWSSCHAIN=1** (Enable the secondary chain.)
 - v. **AT!DASCHAN=<channel>** (Set modem channel)
▪ See [Table 12-8](#) and [Table 12-9](#) for <channel> values
 - vi. **AT!DASLNAGAIN=0** (Set the LNA to maximum gain.)
 - vii. **AT!DAWGAVGAGC=9400,0,1** (The '1' indicates the diversity path used.)
 - c. Test the limits as in [Step 3](#).

12.7 LTE RF Receive Path Test

Note: This procedure segment is performed in [Step 14](#) of the [Production Test Procedure](#) on page 143.

The suggested test procedure that follows uses the parameters in the following tables.

Table 12-11: Test Settings — RC7611, RC7611D, RC7612 LTE Receive Path

Band		Frequency ^a (MHz)	Band ID	Channel ^b
1900 MHz	B2	1962.00	43	18900
1700 MHz	B4	2134.50	42	20175
850 MHz	B5	883.50	45	20525
700 MHz	B12	739.50	50	23095
780 MHz	B13	753.00	36	23230
700 MHz	B14	763.0	51	23330
1900 MHz	B25	1964.5	61	26365
850 MHz	B26	878.5	62	26865
1700 MHz	B66	2157	83	132322
600 MHz	B71	635.5	97	133297

- a. Receive frequencies shown are 2 MHz offset from center
- b. Channel value used by the `!DASCHAN` command (`!DASCHAN` uses uplink (Tx) channel at the center of the corresponding band, for both Tx and Rx testing)

Table 12-12: Test Settings — RC7620 LTE Receive Path

Band		Frequency ^a (MHz)	Band ID	Channel ^b
2100 MHz	B1	2142.00	34	18300
1800 MHz	B3	1844.5	44	19575
2600 MHz	B7	2657.00	35	21100
900 MHz	B8	944.5	47	21625
800 MHz	B20	808.00	56	24300
700 MHz	B28	782.5	64	27435

- a. Receive frequencies shown are 2 MHz offset from center
- b. Channel values shown are at the center of the corresponding bands.

Table 12-13: Test Settings — RC7630 LTE Receive Path

Band		Frequency ^a (MHz)	Band ID	Channel ^b
2100 MHz	B1	2142	34	18300
1800 MHz	B3	1844.5	44	19575
850 MHz	B5	883.5	45	20525
2600 MHz	B7	2657	35	21100
900 MHz	B8	944.5	47	21625
800 MHz	B18	869.5	54	23925
800 MHz	B19	884.5	55	24075
1500 MHz	B21	1505.5	57	24525

- a. Receive frequencies shown are 2 MHz offset from center.
- b. Channel values shown are at the center of the corresponding bands.

Table 12-14: Test Settings — RC7630J^a LTE Receive Path

Band		Frequency ^b (MHz)	Band ID	Channel ^c
2100 MHz	B1	2142	34	18300
1800 MHz	B3	1844.5	44	19575
850 MHz	B5	883.5	45	20525
800 MHz	B18	869.5	54	23925
800 MHz	B19	884.5	55	24075

- a. Limited availability.
- b. Receive frequencies shown are 2 MHz offset from center.
- c. Channel values shown are at the center of the corresponding bands.

To test the DUT's receive path (or diversity path, while connected to the diversity antenna):

Note: This procedure describes steps using the Agilent 8648C signal generator—the Rohde & Schwarz SML03 is shown for reference only.

1. Set up the signal generator:

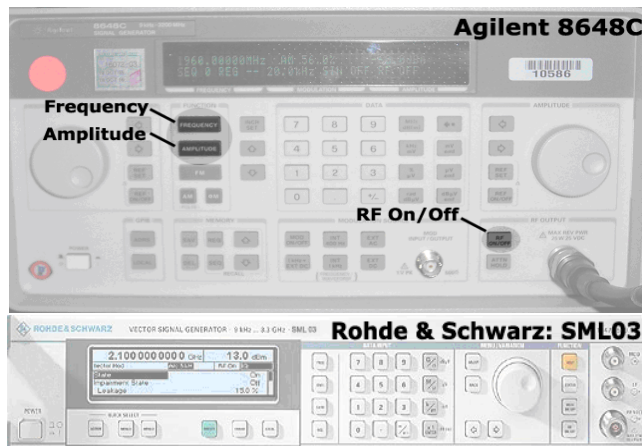

- a. Set the amplitude to -70 dBm
 - b. Set the frequency for the band being tested. See [Table 12-11](#) on page 153 for frequency values.
2. Set up the DUT:
 - a. **AT!ENTERCND="<password>"** (Unlock extended AT command set.)
 - b. **AT!DAFTMACT** (Put modem into factory test mode.)
 - c. **AT!DASBAND=<band>** (Set frequency band.)
See tables [Table 12-11](#) on page 153 for <band> values
 - d. **AT!DALSRXBW=2** (Set Rx LTE bandwidth to 5MHz.)
 - e. **AT!DALSTXBW=2** (Set Tx LTE bandwidth to 5MHz.)
 - f. **AT!DASCHAN=<channel>** (Set modem channel)
 - See tables [Table 12-11](#) on page 153 for <channel> values
 - g. **AT!DALGAVGAGC=<channel>, 0** (Get averaged Rx AGC)
 - See tables [Table 12-11](#) on page 153 for <channel> values
 3. Test limits — Run ten or more good DUTs through this test procedure to obtain a nominal received power value.
 - Apply a tolerance of ± 5 to 6 dB to each measurement (assuming a good setup design).
 - Make sure the measurement is made at a high enough level that it is not influenced by DUT-generated and ambient noise.
 - The Signal Generator power level can be adjusted and new limits found if the radiated test needs greater signal strength.
 - Monitor these limits during mass-production ramp-up to determine if further adjustments are needed.

Note: The value measured from the DUT is significantly influenced by the test setup and DUT design (host RF cabling loss, antenna efficiency and pattern, test antenna efficiency and pattern, and choice of shield box).

12.8 GNSS RF Receive Path Test

The GNSS receive path uses the dedicated GNSS connector.

To test the GNSS receive path:

1. Inject a carrier signal at -110dBm, frequency 1575.52 MHz into the GNSS Rx path at the connector. (Note that this frequency is 100 kHz higher than the actual GPS L1 center frequency.)

-
2. Test the signal carrier-to-noise level at the GNSS receiver:
 - a. **AT!ENTERCND="<password>"** (Unlock extended AT command set.)
 - b. **AT!DAFTMACT** (Put modem into factory test mode.)
 - c. **AT!DACGPSTESTMODE=1** (Start CGPS diagnostic task.)
 - d. **AT!DACGPSSTANDALONE=1** (Enter standalone RF mode.)
 - e. **AT!DACGPSMASKON** (Enable log mask.)
 - f. **AT!DACGPSCTON** (Return signal-to-noise and frequency measurements.)
 - g. Repeat **AT!DACGPSCTON** five to ten times to ensure the measurements are repeatable and stable.
 3. Leave the RF connection to the embedded module intact, and turn off the signal generator.
 4. Take several more **!DACGPSCTON** readings. This will demonstrate a 'bad' signal in order to set limits for testing, if needed. This frequency offset should fall outside of the guidelines in the note below, which indicates that the CtoN result is invalid.
 5. (Optional) Turn the signal generator on again, and reduce the level to -120dBm. Take more **!DACGPSCTON** readings and use these as a reference for what a marginal / poor signal would be.

*Note: The response to **AT!DACGPSCTON** for a good connection should show CtoN within 58 +/- 5dB and Freq (frequency offset) within 100000 Hz +/- 5000 Hz.*

A: Appendix

For more details, several references can be consulted, as detailed below.

A.1 Web Site Support

Check <http://source.sierrawireless.com> for the latest documentation available.

A.2 Reference Documents

- [1] RC76xx AT Command Reference
Reference number: 41113566
- [2] RC76xx Scalability Guide
Reference number: 41113646
- [3] RC76xx Customer Process Guidelines
Reference number: 41113573
- [4] Inter-Chip USB Supplement to the USB 2.0 Specification Revision 1.0
- [5] I²C Bus Specification, Version 5.0, October 2012
Reference: Phillips Semiconductor document number 9398 393 40011

A.3 Abbreviations

Acronym or Term	Definition
3GPP	3rd Generation Partnership Project
8PSK	Octagonal Phase Shift Keying
ADC	Analog to Digital Converter
AF	Audio-Frequency
API	Application Programming Interface
AT	Attention (prefix for modem commands)
BeiDou	BeiDou Navigation Satellite System A Chinese system that uses a series of satellites in geostationary and middle earth orbits to provide navigational data.
BER	Bit Error Rate — A measure of receive sensitivity
BLER	Block Error Rate
Bluetooth	Wireless protocol for data exchange over short distances
CEP CEP-##	Circular Error Probability — Measure of GPS horizontal accuracy indicating the radius of a circle around the actual position that contains 50% of GPS measurements. CEP-## — Radius of circle containing ##% of GPS measurements (e.g. CEP-90 indicates 90% of measurements contained within circle)

Acronym or Term	Definition
CF3	Common Flexible Form Factor
CLK	Clock
CMOS	Complementary Metal Oxide Semiconductor
CPU	Central Processing Unit
CQI	Channel Quality Indication
CS	Circuit-Switched
	Coding Scheme
CTS	Clear To Send
CW	Continuous waveform
DAC	Digital to Analog Converter
dB	Decibel = $10 \times \log_{10} (P1 / P2)$ <i>P1 is calculated power; P2 is reference power</i> Decibel = $20 \times \log_{10} (V1 / V2)$ <i>V1 is calculated voltage, V2 is reference voltage</i>
dBm	A logarithmic (base 10) measure of relative power (dB for decibels); relative to milliwatts (m). A dBm value will be 30 units (1000 times) larger (less negative) than a dBW value, because of the difference in scale (milliwatts vs. watts).
DC	Direct Current
DCD	Data Carrier Detect
DCS	Digital Cellular System A cellular communication infrastructure that uses the 1.8 GHz radio spectrum.
DL	Downlink (network to mobile)
DRX	Discontinuous Reception
DSR	Data Set Ready
DSSS	Dual SIM Single Standby
DTR	Data Terminal Ready
eDRX	Extended Discontinuous Reception
E-GSM	Extended GSM
EDGE	Enhance Data rates for GSM Evolution
EFR	Enhanced Full Rate
EGPRS	Enhance GPRS
EIRP	Effective (or Equivalent) Isotropic Radiated Power
EMC	Electromagnetic Compatibility
EN	Enable

Acronym or Term	Definition
ERP	Effective Radiated Power
ESD	Electrostatic Discharges
eSIM	Embedded SIM
ETSI	European Telecommunications Standards Institute
FCC	Federal Communications Commission The U.S. federal agency that is responsible for interstate and foreign communications. The FCC regulates commercial and private radio spectrum management, sets rates for communications services, determines standards for equipment, and controls broadcast licensing. Consult www.fcc.gov .
FDD	Frequency Division Duplex
FDMA	Frequency Division Multiple Access
firmware	Software stored in ROM or EEPROM; essential programs that remain even when the system is turned off. Firmware is easier to change than hardware but more permanent than software stored on disk.
FOV	Field Of View
FR	Full Rate
FSN	Factory Serial Number—A unique serial number assigned to the module during manufacturing.
Galileo	A European system that uses a series of satellites in middle earth orbit to provide navigational data.
GCF	Global Certification Forum
GLONASS	Global Navigation Satellite System — A Russian system that uses a series of 24 satellites in middle circular orbit to provide navigational data.
GMSK	Gaussian Minimum Shift Keying modulation
GND	Ground
GNSS	Global Navigation Satellite Systems (GPS, GLONASS, BeiDou, Galileo, and QZSS)
GPIO	General Purpose Input Output
GPRS	General Packet Radio Service
GPS	Global Positioning System An American system that uses a series of 24 satellites in middle circular orbit to provide navigational data.
GSM	Global System for Mobile communications
Hi Z	High impedance (Z)
Host	The device into which an embedded module is integrated
HR	Half Rate
HSDPA	High Speed Downlink Packet Access
HSUPA	High Speed Uplink Packet Access

Acronym or Term	Definition
Hz	Hertz = 1 cycle/second
I/O	Input/Output
IC	Industry Canada
IC	Integrated Circuit
I-eDRX	Idle mode eDRX
IMEI	International Mobile Equipment Identity
IMS	IP Multimedia Subsystem— Architectural framework for delivering IP multimedia services.
inrush current	Peak current drawn when a device is connected or powered on
IOT	Interoperability Testing
IS	Interim Standard. After receiving industry consensus, the TIA forwards the standard to ANSI for approval.
ISIM	IMS Subscriber Identity Module.
LED	Light Emitting Diode. A semiconductor diode that emits visible or infrared light.
LGA	Land Grid Array
LHCP	Left-Hand Circular Polarized
LNA	Low noise Amplifier
LTE	Long Term Evolution—a high-performance air interface for cellular mobile communication systems.
MAX	Maximum
MCS	Modulation and Coding Scheme
MHz	Megahertz = 10^6 Hz
MIC	Microphone
MIMO	Multiple Input Multiple Output—wireless antenna technology that uses multiple antennas at both transmitter and receiver side. This improves performance.
MIN	Minimum
MO	Mobile Originated
MT	Mobile Terminated
N/A	Not Applicable
NMEA	National Marine Electronics Association
NOM	Nominal
OEM	Original Equipment Manufacturer—a company that manufactures a product and sells it to a reseller.
OTA	Over the Air Technology

Acronym or Term	Definition
PA	Power Amplifier
packet	A short, fixed-length block of data, including a header, that is transmitted as a unit in a communications network.
PBCCH	Packet Broadcast Control Channel
PC	Personal Computer
PCB	Printed Circuit Board
PCL	Power Control Level
PCS	Personal Communication System A cellular communication infrastructure that uses the 1.9 GHz radio spectrum.
PDN	Packet Data Network
PFM	Power Frequency Modulation
PLL	Phase Lock Loop
PMIC	Power Management Integrated Circuit
PSM	Power Saving Mode
PSS	Primary synchronization signal
PST	Product Support Tools
PTCRB	PCS Type Certification Review Board
PWM	Pulse Width Modulation
QAM	Quadrature Amplitude Modulation. This form of modulation uses amplitude, frequency, and phase to transfer data on the carrier wave.
QPSK	Quadrature Phase-Shift Keying
QZSS	Quasi-Zenith Satellite System
R2C	Ready-To-Connect
RAM	Random Access Memory
RAT	Radio Access Technology
RF	Radio Frequency
RHCP	Right Hand Circular Polarization
RI	Ring Indicator
RSE	Radiated Spurious Emissions
RSSI	Received Signal Strength Indication
RST	Reset
RTC	Real Time Clock

Acronym or Term	Definition
RTS	Request To Send
RX	Receive
SCLK	Serial Clock
SED	Smart Error Detection
Sensitivity (Audio)	Measure of lowest power signal that the receiver can measure.
Sensitivity (RF)	Measure of lowest power signal at the receiver input that can provide a prescribed BER/BLER/SNR value at the receiver output.
SIM	Subscriber Identity Module.
SIMO	Single Input Multiple Output—Wireless antenna technology that uses multiple antennas at the receiver side and one antenna at the source (transmitter).
SKU	Stock Keeping Unit—identifies an inventory item: a unique code, consisting of numbers or letters and numbers, assigned to a product by a retailer for purposes of identification and inventory control.
SMS	Short Message Service
SNR	Signal-to-Noise Ratio
SPI	Serial Peripheral Interface
SPK	Speaker
SW	Software
TBC	To Be Confirmed
TBD	To Be Determined
TDD	Time Division Duplex
TIA/EIA	Telecommunications Industry Association / Electronics Industry Association. A standards setting trade organization, whose members provide communications and information technology products, systems, distribution services and professional services in the United States and around the world. Consult www.tiaonline.org .
TIS	Total Isotropic Sensitivity
TP	Test Point
TRP	Total Radiated Power
TX	Transmit
TYP	Typical
UART	Universal Asynchronous Receiver-Transmitter
UE	User Equipment
UICC	Universal Integrated Circuit Card
UIM	User Identity Module. Generic term used in this document to refer to UICC, where the application on the UICC (USIM, ISIM, CSIM, etc.) varies depending on the provider of the card.

Acronym or Term	Definition
UL	Uplink (mobile to network)
UMTS	Universal Mobile Telecommunications System
USB	Universal Serial Bus
USB-SS	USB Selective Suspend/USB not enumerated
USIM	Universal Subscriber Identity Module (UMTS)
USSD	Unstructured Supplementary Services Data
UTRA	UMTS Terrestrial Radio Access
VBATT	VBATT is a virtual signal that represents both VBAT_BB and VBAT_RF
VBAT_BB	Baseband power supply
VBAT_RF	RF power supply
VCC	Supply voltage
VSWR	Voltage Standing Wave Ratio
WCDMA	Wideband Code Division Multiple Access (also referred to as UMTS)
WLAN	Wireless Local Area Network
WWAN	Wireless Wide Area Network
ZIF	Zero Intermediate Frequency