

Author: Sierra Wireless		Date: November 26, 2013	
APN Content Level	BASIC	INTERMEDIATE	<input checked="" type="checkbox"/> ADVANCED
Confidentiality		Public	<input checked="" type="checkbox"/> Private
Hardware Compatibility	Product Line	AirPrime	Series
		Q26xx	SL60xx
			WMPxx
Software Compatibility	Series		ALL



1 Version

Application Notes may be updated over their lifetime. To ensure you design with the correct version, please check the application notes page in www.sierrawireless.com for latest versions.

2 Introduction

This Application Note (APN) is provided to Sierra Wireless distributors and clients to aid more rapid development of embedded applications using the Sierra Wireless portfolio of cellular solutions. To request a new application note, contact your regional Sierra Wireless Product Marketing Manager.

3 Overview

This Application Note describes a method to wake up an embedded module by motion detection through the use of a 3 axis accelerometer.

Generally, when an AirPrime embedded module is not needed in working mode, the best way to save energy is to enter into ALARM mode. It can then be woken up by programming an RTC interrupt. However, in specific applications, it can be useful to wake up the AirPrime module when a movement is detected. This application note shows a method to implement this mechanism.

4 Description

This wake up method is based on the use of a 3 axis Accelerometer. As soon as this device is moved, a GPIO is toggled and used to activate the ON/OFF signal of the embedded module.

As this interrupt signal is only a pulse, in order to meet the ON/OFF signal specification, an RS FLIP FLOP is used.

The GPIO sets the RS FLIP FLOP maintaining the ON/OFF high, enabling the AirPrime module to power up normally.

Once the required task has been performed, the system can enter the ALARM mode again to save energy. To enter ALARM mode, the ON/OFF input signal should be first reset to a low level, using one of its own GPIO.

The block diagram below shows the implementation of this system.

5 Block Diagram

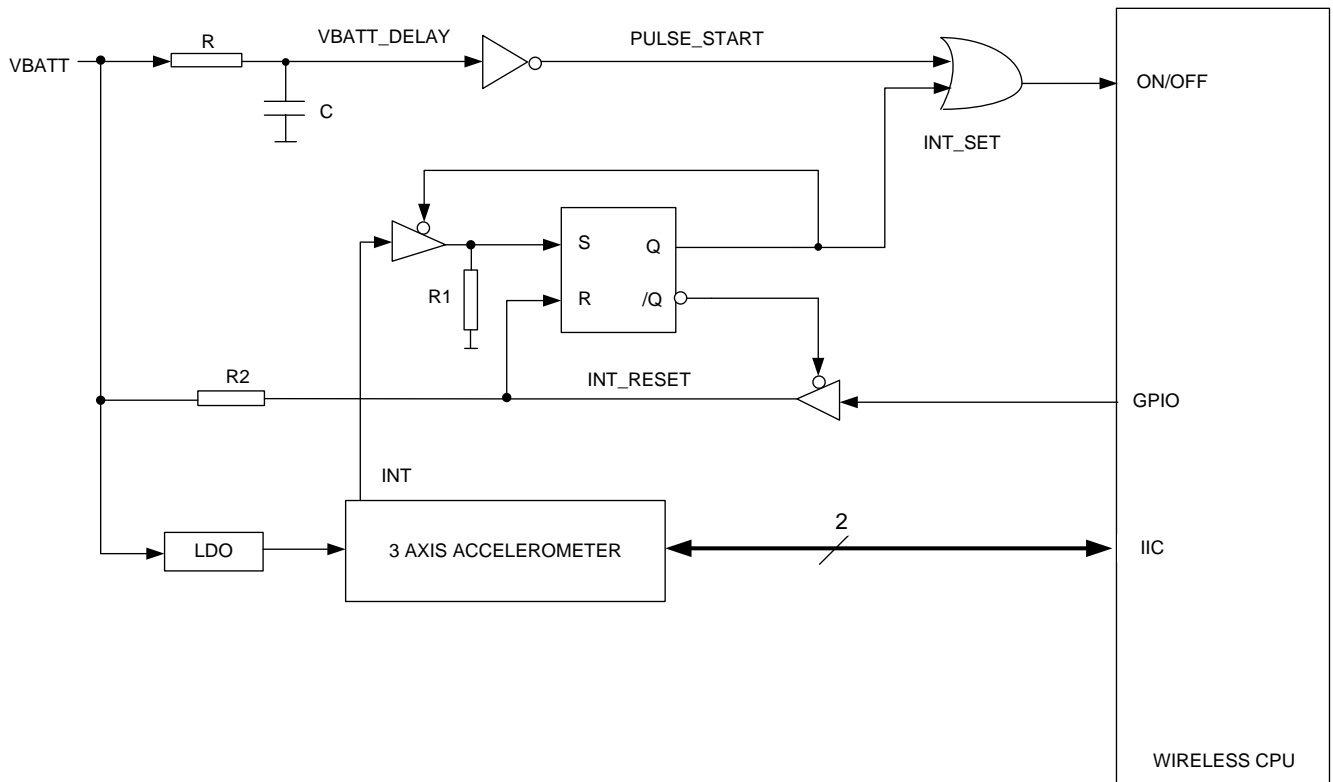

The RC and associated inverter are used to generate the ON/OFF signal.

The 3 axis accelerometer needs to be programmed through I2C bus at power ON.

When the embedded module has performed the required actions task, it can then be switched to ALARM mode by AT command (AT+CPOF).

As soon as a motion is detected on the 3 axis accelerometer, an INT signal is issued from it, setting the RS FLIP FLOP (INT_SET) high. The INT_SET signal is then applied to the ON/OFF signal to restart the module which then leaves ALARM mode and power up normally. When the module needs to return to ALARM mode, to save energy, the INT_SET signal must be reset to leave the ON/OFF low. The internal GPIO is set high through an AT command (INT_RESET) to reset the INT_SET signal, after this the AT+CPOF can switch the module OFF (return to ALARM mode).

The below timing diagram shows the main signal states.

6 Signals Timing

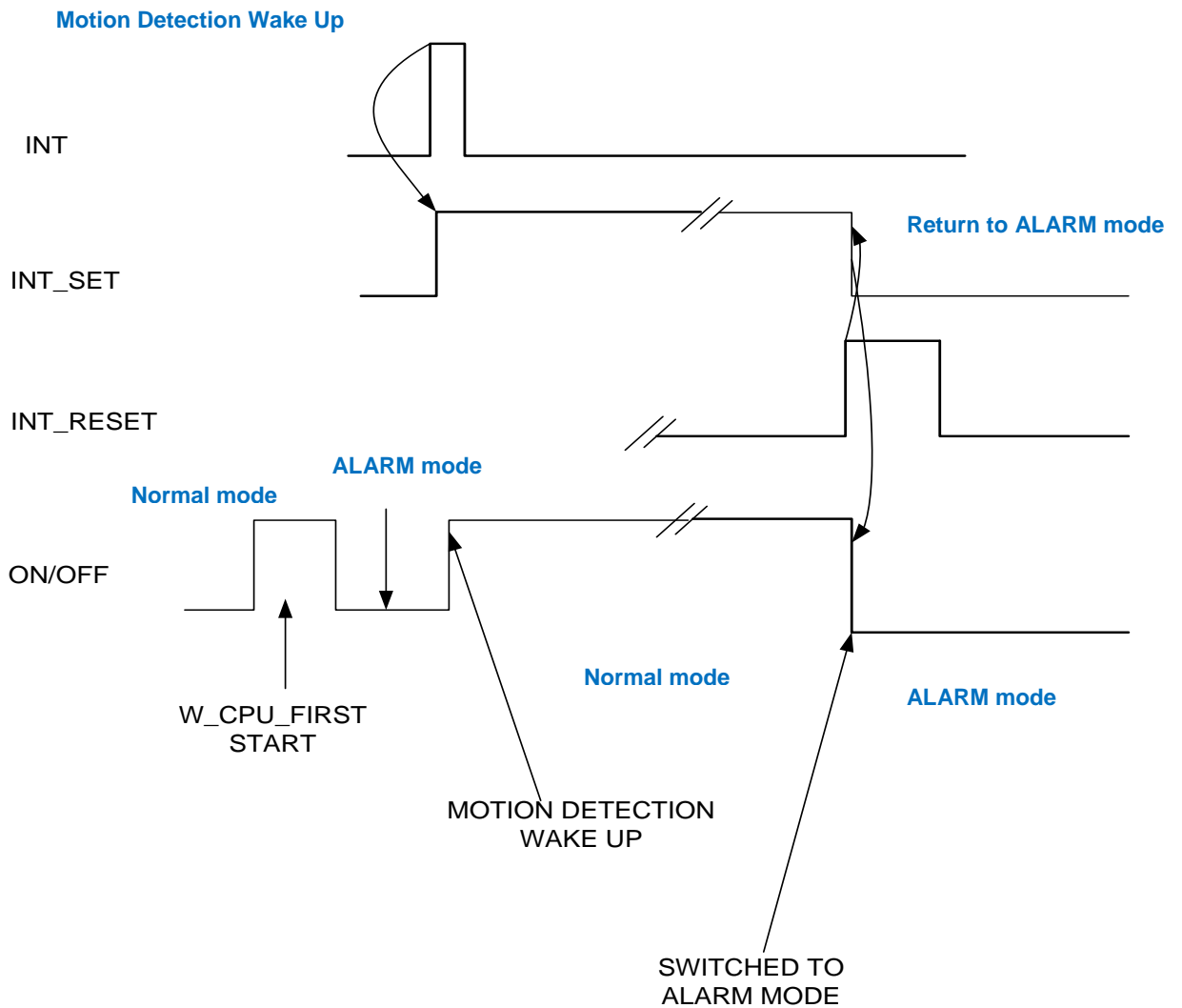
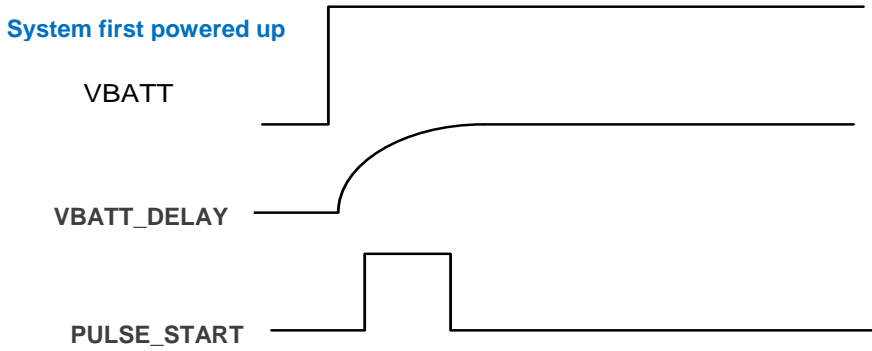

When the user needs to program an alarm and enter alarm mode, the below steps should be followed:

1. Switch the ON/OFF signal to low by programming a pulse on GPIOXX:
 - AT command to be sent to have a pulse AT+WIOW=XX,1 ; AT+WIOW=Xx,0.
2. Enter the AT+CALA command to program the alarm.
3. Enter the AT+CPOF command to switch the module OFF (ALARM mode).

7 Document History

Level	Date	History
1.0	November 26, 2013	Creation

8 Legal Notice

Important Notice

Due to the nature of wireless communications, transmission and reception of data can never be guaranteed. Data may be delayed, corrupted (i.e., have errors) or be totally lost. Although significant delays or losses of data are rare when wireless devices such as the Sierra Wireless modem are used in a normal manner with a well-constructed network, the Sierra Wireless modem should not be used in situations where failure to transmit or receive data could result in damage of any kind to the user or any other party, including but not limited to personal injury, death, or loss of property. Sierra Wireless accepts no responsibility for damages of any kind resulting from delays or errors in data transmitted or received using the Sierra Wireless modem, or for failure of the Sierra Wireless modem to transmit or receive such data.

Safety and Hazards

Do not operate the Sierra Wireless modem in areas where cellular modems are not advised without proper device certifications. These areas include environments where cellular radio can interfere such as explosive atmospheres, medical equipment, or any other equipment which may be susceptible to any form of radio interference. The Sierra Wireless modem can transmit signals that could interfere with this equipment. Do not operate the Sierra Wireless modem in any aircraft, whether the aircraft is on the ground or in flight. In aircraft, the Sierra Wireless modem **MUST BE POWERED OFF**. When operating, the Sierra Wireless modem can transmit signals that could interfere with various onboard systems.

Note: Some airlines may permit the use of cellular phones while the aircraft is on the ground and the door is open. Sierra Wireless modems may be used at this time.

The driver or operator of any vehicle should not operate the Sierra Wireless modem while in control of a vehicle. Doing so will detract from the driver or operator's control and operation of that vehicle. In some states and provinces, operating such communications devices while in control of a vehicle is an offence.

Limitations of Liability

This manual is provided "as is". Sierra Wireless makes no warranties of any kind, either expressed or implied, including any implied warranties of merchantability, fitness for a particular purpose, or noninfringement. The recipient of the manual shall endorse all risks arising from its use.

The information in this manual is subject to change without notice and does not represent a commitment on the part of Sierra Wireless. SIERRA WIRELESS AND ITS AFFILIATES SPECIFICALLY DISCLAIM LIABILITY FOR ANY AND ALL DIRECT, INDIRECT, SPECIAL, GENERAL, INCIDENTAL, CONSEQUENTIAL, PUNITIVE OR EXEMPLARY DAMAGES INCLUDING, BUT NOT LIMITED TO, LOSS OF PROFITS OR REVENUE OR ANTICIPATED PROFITS OR REVENUE ARISING OUT OF THE USE OR INABILITY TO USE ANY SIERRA WIRELESS PRODUCT, EVEN IF SIERRA WIRELESS AND/OR ITS AFFILIATES HAS BEEN ADVISED OF THE POSSIBILITY OF SUCH DAMAGES OR THEY ARE FORESEEABLE OR FOR CLAIMS BY ANY THIRD PARTY.

Notwithstanding the foregoing, in no event shall Sierra Wireless and/or its affiliates aggregate liability arising under or in connection with the Sierra Wireless product, regardless of the number of events, occurrences, or claims giving rise to liability, be in excess of the price paid by the purchaser for the Sierra Wireless product.

Customer understands that Sierra Wireless is not providing cellular or GPS (including A-GPS) services. These services are provided by a third party and should be purchased directly by the Customer.

SPECIFIC DISCLAIMERS OF LIABILITY: CUSTOMER RECOGNIZES AND ACKNOWLEDGES SIERRA WIRELESS IS NOT RESPONSIBLE FOR AND SHALL NOT BE HELD LIABLE FOR ANY DEFECT OR DEFICIENCY OF ANY KIND OF CELLULAR OR GPS (INCLUDING A-GPS) SERVICES.

Patents

This product may contain technology developed by or for Sierra Wireless Inc.

This product includes technology licensed from QUALCOMM®.

This product is manufactured or sold by Sierra Wireless Inc. or its affiliates under one or more patents licensed from InterDigital Group and MMP Portfolio Licensing.

Copyright

© 2013 Sierra Wireless. All rights reserved.

Trademarks

Sierra Wireless®, AirPrime®, AirLink®, AirVantage® and the Sierra Wireless logo are registered trademarks of Sierra Wireless.

Watcher® is a registered trademark of Netgear, Inc., used under license.

Windows® and Windows Vista® are registered trademarks of Microsoft Corporation.

Macintosh® and Mac OS X® are registered trademarks of Apple Inc., registered in the U.S. and other countries.

QUALCOMM® is a registered trademark of QUALCOMM Incorporated. Used under license.

Other trademarks are the property of their respective owners.