



# Product Technical Specification

## WP7702

## Important Notice

Information relating to this product and the application or design described herein is believed to be reliable, however such information is provided as a guide only and Semtech assumes no liability for any errors in this document, or for the application or design described herein.

Semtech reserves the right to make changes to the product or this document at any time without notice. Buyers should obtain the latest relevant information before placing orders and should verify that such information is current and complete. Semtech warrants performance of its products to the specifications applicable at the time of sale, and all sales are made in accordance with Semtech's standard terms and conditions of sale.

SEMTECH PRODUCTS ARE NOT DESIGNED, INTENDED, AUTHORIZED OR WARRANTED TO BE SUITABLE FOR USE IN LIFE-SUPPORT APPLICATIONS, DEVICES OR SYSTEMS, OR IN NUCLEAR APPLICATIONS IN WHICH THE FAILURE COULD BE REASONABLY EXPECTED TO RESULT IN PERSONAL INJURY, LOSS OF LIFE OR SEVERE PROPERTY OR ENVIRONMENTAL DAMAGE. INCLUSION OF SEMTECH PRODUCTS IN SUCH APPLICATIONS IS UNDERSTOOD TO BE UNDERTAKEN SOLELY AT THE CUSTOMER'S OWN RISK. Should a customer purchase or use Semtech products for any such unauthorized application, the customer shall indemnify and hold Semtech and its officers, employees, subsidiaries, affiliates, and distributors harmless against all claims, costs damages and attorney fees which could arise.

The Semtech name and logo are registered trademarks of the Semtech Corporation. All other trademarks and trade names mentioned may be marks and names of Semtech or their respective companies. Semtech reserves the right to make changes to, or discontinue any products described in this document without further notice. Semtech makes no warranty, representation or guarantee, express or implied, regarding the suitability of its products for any particular purpose. All rights reserved.

## Wireless Communications

Due to the nature of wireless communications, transmission and reception of data can never be guaranteed. Data may be delayed, corrupted (i.e., have errors) or be totally lost. The Semtech product should not be used in situations where failure to transmit or receive data could result in damage of any kind to the user or any other party, including but not limited to personal injury, death, or loss of property. Semtech accepts no responsibility for damages of any kind resulting from delays or errors in data transmitted or received using the Semtech product, or for failure of the Semtech product to transmit or receive such data.

## Safety

Do not operate the Semtech product in areas where blasting is in progress, where explosive atmospheres may be present, near medical equipment, near life support equipment, or near any equipment which may be susceptible to any form of radio interference. In such areas, the Semtech product should be powered off.

## Qualcomm Licenses

Semtech's cellular modules are sold subject to certain notices and restrictions regarding patent licenses from Qualcomm Incorporated. These notices and restrictions are available at [www.sierrawireless.com/qualcomm-notices](http://www.sierrawireless.com/qualcomm-notices).

## Sierra Wireless

Semtech Corporation acquired Sierra Wireless in January 2023. The Sierra Wireless brand is gradually being phased out. During the phase-out period, references to both “Semtech” and “Sierra Wireless” may appear in product documentation.

## Contact Information

Sales information and technical support, including warranty and returns	Web: <a href="http://sierrawireless.com/company/contact-us/">sierrawireless.com/company/contact-us/</a> Global toll-free number: 1-877-687-7795 6:00 am to 5:00 pm PST
Corporate and product information	Web: <a href="http://sierrawireless.com">sierrawireless.com</a>

## Revision History

Revision number	Release date	Changes
1	October 2017	Creation (limited release)
2	January 2018	General release
3	October 2018	Corrected WWAN_LED_N maximum current Updated Signal Timing graphic — shifted SAFE_PWR_REMOVE transition points; added Host Signals detail Updated Wakeup Interrupt (Sleep State) — noted use of +WIOCFG to configure GPIOs Updated SPI max frequency Updated Power Saving Mode (PSM) — added note for POWER_ON_N signal (floating)
4	March 2019	Updated I <sup>2</sup> C Interface — address restriction Added GPS week rollover note Corrected Figure 4-1 Signal Timing (start/end positions of t_pwr_remove) Removed ‘preliminary’ footnotes Updated Software-Initiated Power Down procedure Updated Current Consumption Values table — Removed all remaining ‘TBD’/‘TBC’
5	February 2020	Removed PCM/I <sup>2</sup> S Audio content
6	March 2021	Removed WP7700 content Marked pins J1-J9 as Reserved Updated Application Core L1 cache details Updated VGPI0 — Clarified VGPI0 state (floating) when OFF or in ULPS Updated Embedded Memory topic — added Flash Memory and RAM subtopics Updated Firmware Upgrades topic — added downgrade notice; added FOTA recommendation Added ANATEL mark

Revision number	Release date	Changes
7	June 2025	Updated Table 4-6 GPIO Pin Descriptions Updated Table 10-1: Pin Definitions - Pin 65 Updated to the Semtech manual template

# Contents

- Important Notice ..... 2
- Wireless Communications..... 2
- Safety..... 2
- Qualcomm Licenses ..... 2
- Sierra Wireless ..... 3
- Contact Information ..... 3
- Revision History ..... 3
  
- 1: Introduction .....11**
  - 1.1 General Features..... 11
  - 1.2 Interfaces ..... 12
  - 1.3 Common Flexible Form Factor (CF3)..... 13
  - 1.4 Physical Dimensions and Connection Interface..... 13
  - Related Documents..... 14
  
- 2: Functional Specifications .....15**
  - 2.1 Architecture ..... 15
  - 2.2 Telecom Features ..... 16
    - 2.2.1 Network Technology Specifications ..... 16
    - 2.2.2 Radio Access Technology (RAT) Selection..... 20
    - 2.2.3 Modem Specifications..... 21
  - 2.3 Multi-Core Processing Capabilities ..... 21
  
- 3: Technical Specifications .....22**
  - 3.1 Environmental ..... 22
  - 3.2 Power Supply Ratings ..... 22
    - 3.2.1 Under-Voltage Lockout (UVLO) ..... 24
    - 3.2.2 Power Consumption States..... 25
    - 3.2.3 Power Saving Mode (PSM) ..... 30
    - 3.2.4 Active State to ULPS Transition..... 32
    - 3.2.5 Extended Discontinuous Reception (eDRX) ..... 33
    - 3.2.6 Current Consumption ..... 35

3.3 RF.....	38
3.3.1 GPRS/EDGE RF Interface.....	39
3.3.2 LTE RF Interface.....	40
3.3.3 WWAN Antenna Interface.....	41
3.4 GNSS.....	43
3.4.1 GNSS Characteristics.....	43
3.4.2 GNSS Antenna Interface.....	44
3.5 Electrical Specifications.....	46
3.5.1 Absolute Maximum Ratings.....	46
3.5.2 Digital I/O Characteristics.....	47
3.5.3 Internal Device Frequencies.....	49
3.6 Processing.....	50
3.6.1 Application Core.....	50
3.6.2 Embedded Memory.....	50
3.6.3 Recovery Mechanism.....	53
3.6.4 Secure Boot/Secure Debug.....	53
3.7 Mechanical Drawing.....	54
3.8 Labeling.....	55
<b>4: Interfaces Specification.....</b>	<b>56</b>
4.1 Overview.....	56
4.2 POWER_ON_N.....	56
4.2.1 Power-up Sequence.....	56
4.2.2 Software-Initiated Power Down.....	57
4.3 Emergency Power Off.....	58
4.4 Tx Power Control.....	58
4.5 USB.....	58
4.6 UART.....	59
4.7 UIM Interface.....	60
4.8 General Purpose Input/Output (GPIO).....	61
4.9 Wakeup Interrupt (Sleep State).....	63
4.10 Wakeup Events (ULPS).....	63

---

4.11 Secure Digital IO (SDIO) Interface .....	64
4.12 I2C Interface .....	64
4.12.1 Application .....	65
4.13 VGPIO .....	65
4.14 Reset Signal (RESET_IN_N) .....	66
4.15 Reset Out (RESET_OUT_N) .....	67
4.16 ADC .....	67
4.17 SPI Bus .....	68
4.17.1 SPI Configuration .....	69
4.17.2 SPI Waveforms .....	69
4.17.3 Application .....	70
4.18 HSIC Bus .....	70
4.18.1 HSIC Waveforms .....	70
4.18.2 Application .....	71
4.19 Clock .....	71
4.20 TP1 (Boot Pin) .....	71
4.21 Temperature Monitoring .....	72
4.22 Test Pins .....	73
4.23 Antenna Control .....	73
4.24 Indication Interfaces .....	74
4.24.1 Tx Activity Indicator (TX_ON) .....	75
4.24.2 WWAN_LED_N .....	75
4.24.3 WAKE_ON_WWAN .....	76
4.24.4 Ring Indicator .....	76
4.24.5 SAFE_PWR_REMOVE .....	76
4.24.6 UIM1_DET .....	77
4.25 DR_SYNC .....	77
4.26 W_DISABLE_N—Wireless Disable .....	77
<b>5: Routing Constraints and Recommendations .....</b>	<b>79</b>
5.1 General Rules and Recommendations .....	79
5.2 PCB Layout Recommendations .....	79

---

5.3 Power Supply .....	79
5.4 Antenna .....	79
5.5 PCB Specifications for the Application Board .....	80
5.6 Recommended PCB Land Pattern .....	80
5.7 Routing Constraints .....	80
5.7.1 Power Supply .....	80
5.7.2 UIM Interface .....	81
5.7.3 RF Circuit .....	81
5.7.4 USB Interface .....	83
5.8 Thermal Considerations .....	83
5.9 EMC and ESD Recommendations .....	83
5.10 Mechanical Integration .....	84
5.11 Signal Reference Schematics .....	85
<b>6: Software and Tools .....</b>	<b>.87</b>
6.1 Support Tools .....	87
6.2 SED (Smart Error Detection) .....	87
6.3 Firmware Upgrade .....	87
6.3.1 FOTA Recommendation .....	87
<b>7: Debug and Assembly Considerations .....</b>	<b>.88</b>
7.1 Testing Assistance Provided by Semtech .....	88
7.2 Integration Requirements .....	88
7.3 IOT/Operator .....	88
7.4 Module Testing Recommendations .....	88
7.5 Serial Link Access .....	88
7.6 RF Output Accessibility .....	89
<b>8: Reliability Specification .....</b>	<b>.90</b>
8.1 Reliability Compliance .....	90
8.2 Reliability Prediction Model .....	90
8.2.1 Life Stress Test .....	90

---

8.2.2 Environmental Resistance Stress Tests .....	91
8.2.3 Corrosive Resistance Stress Tests .....	91
8.2.4 Thermal Resistance Cycle Stress Tests .....	92
8.2.5 Mechanical Resistance Stress Tests .....	93
8.2.6 Handling Resistance Stress Tests .....	94
<b>9: Approval .....</b>	<b>95</b>
9.1 Disposing of the Product .....	95
9.2 Important Notice .....	95
9.3 Safety and Hazards .....	95
9.4 Compliance Acceptance and Certification .....	95
9.5 Certification Compliance .....	96
9.5.1 Important Compliance Information for North America .....	96
9.5.2 ANATEL (Brazil) .....	97
<b>10: Pinout .....</b>	<b>98</b>
Pin Configuration .....	99
Pin Description .....	100
<b>11: Customization .....</b>	<b>107</b>
<b>12: Testing .....</b>	<b>108</b>
12.1 Certification Testing .....	108
12.2 Production Testing .....	108
12.3 Functional Production Test .....	109
12.3.1 Suggested Production Tests .....	109
12.3.2 Production Test Procedure .....	109
12.4 GPRS/EDGE RF Transmission Path Test .....	111
12.5 LTE RF Transmission Path Test .....	113
12.6 GPRS/EDGE RF Receive Path Test .....	115
12.7 LTE RF Receive Path Test .....	117
12.8 GNSS RF Receive Path Test .....	119

<b>A: Appendix</b> .....	<b>120</b>
A.1 Web Site Support .....	120
A.2 Reference Documents.....	120
A.3 Abbreviations .....	121

# 1: Introduction

This document defines high-level product features and illustrates the interfaces for AirPrime WP7702 Smart WP-Series Embedded Modules. The document also describes hardware aspects of the product series, including electrical and mechanical.

AirPrime WP7702 Smart WP-Series Embedded Modules expand Semtech's WP series by implementing key Low Power Wide-Area (LPWA) cellular technology (Cat-M1, Cat-NB1) with PSM (Power Saving Mode) and eDRX (extended Discontinuous Reception), which allow for:

- Significantly extended battery life (up to 10 or more years) compared to broadband LTE, allowing long-term (multi-year) UE deployment
- Extended coverage compared to broadband LTE
- Lower cost vs. broadband LTE

WP7702 modules feature an integrated Linux-based processor configured with the Legato Application Framework, which allows the entire application to be loaded on and run inside the module.

Based on Semtech's CF3 standard, WP7702 modules are compatible with other WP-series module variants (WPx5xx, WP76xx) enabling use of the WP7702 module without requiring application redesign.

## 1.1 General Features

The AirPrime WP7702 is an industrial-grade LGA 239-pad embedded module. Its low-power wireless modem provides data connectivity on the networks listed in [Table 1-1](#).

**Table 1-1: Supported Networks**

Networks	Details
LTE	Cat-M1 (300 kbps DL, 375 kbps UL) Cat-NB1 (27 kbps DL, 65 kbps UL)
EDGE/GPRS	Power class 1 (1800/1900 MHz) Power class 4 (850/900 MHz)

GNSS functionality is also available as a SKU-dependent feature.

In addition to modem features, the AirPrime WP7702 embeds several cores for maximum flexibility and security for embedded software execution, including:

- A Telecom Core that natively manages 4G modem features
- An Application Core dedicated to customer applications, natively provided with Legato Application framework.

[Table 1-2](#) on page 12 details supported RF bands/connectivity.

**Table 1-2: Supported Bands / Connectivity**

Technology	RF band	Transmit band (Tx) (MHz)	Receive band (Rx) (MHz)	Notes
LTE	B1	1920–1980	2110–2170	SIMO
	B2	1850–1910	1930–1990	
	B3	1710–1785	1805–1880	
	B4 <sup>a</sup>	1710–1755	2110–2155	
	B5	824–849	869–894	
	B8	880–915	925–960	
	B12	699–716	729–746	
	B13	777–787	746–756	
	B17 <sup>b</sup>	704–716	734–746	
	B18	815–830	860–875	
	B19	830–845	875–890	
	B20	832–862	791–821	
	B26	814–849	859–894	
	B28	703–748	758–803	
GPRS/EDGE	GSM 850	824–849	869–894	
	E-GSM 900	880–915	925–960	
	DCS 1800	1710–1785	1805–1880	
	PCS_1900	1850–1910	1930–1990	
GNSS <sup>c</sup>	GPS	-	1575.42 ± 1.023	
	GLONASS	-	1597.52–1605.92	
	Galileo	-	1575.42 ± 2.046	
	BeiDou	-	1561.098 ± 2.046	

- a. B4 — CAT-M1 only
- b. B17 — CAT-NB1 only
- c. GNSS support is SKU-dependent.

## 1.2 Interfaces

The AirPrime WP7702 provides the following interfaces and peripheral connectivity:

- Digital section running under 1.8V
- UIM interface — See [UIM Interface](#) on page 60.
- VBAT\_RF/VBAT\_BB power supply — See [Power Supply Ratings](#) on page 22.
- RF — See [RF](#) on page 38.

- GNSS<sup>1</sup> (RF\_GNSS)— See [GNSS](#) on page 43.
- ON/OFF control:
  - POWER\_ON\_N— See [POWER\\_ON\\_N](#) on page 56.
  - RESET\_IN\_N— See [Reset Signal \(RESET\\_IN\\_N\)](#) on page 66.
- USB 2.0— See [USB](#) on page 58.
- UART serial links— See [UART](#) on page 59.
- GPIOs— See [General Purpose Input/Output \(GPIO\)](#) on page 61.
- SDIO— See [Secure Digital IO \(SDIO\) Interface](#) on page 64.
- I<sup>2</sup>C— See [I2C Interface](#) on page 64.
- 1.8V voltage reference— See [VGPIO](#) on page 65.
- ADCs— See [ADC](#) on page 67.
- SPI bus— See [SPI Bus](#) on page 68.
- HSIC bus— See [HSIC Bus](#) on page 70.
- Digital I/O
- Antenna control— See [Antenna Control](#) on page 73.
- System clock outputs— See [Clock](#) on page 71.
- Test pins— See [Test Pins](#) on page 73.
- Tx Activity Indicator (TX\_ON)— See [Tx Activity Indicator \(TX\\_ON\)](#) on page 75.

## 1.3 Common Flexible Form Factor (CF3)

The AirPrime WP7702 belongs to the Common Flexible Form Factor (CF3) family of WWAN modules. These modules share the same mechanical dimensions (same width and length with varying thicknesses) and footprint. The CF3 form factor provides a unique solution to a series of problems faced commonly in the WWAN module space as it:

- Accommodates multiple radio technologies (from GSM to LTE advanced) and band groupings
- Supports bit-pipe (Essential HL-Series) and value-add (Smart WP-Series) solutions
- Offers electrical and functional compatibility

*Note: AT command support varies by module type (WP-series, HL-series). The appropriate AT command references for each device are available on the specific device pages at <http://source.sierrawireless.com>.*

## 1.4 Physical Dimensions and Connection Interface

The AirPrime WP7702 module is a compact, robust, fully shielded (single-piece shield) and labeled module with the dimensions noted in [Table 1-3](#).

**Table 1-3: AirPrime WP7702 Dimensions<sup>a</sup>**

Parameter	Nominal	Tolerance	Units
Length	23.00	±0.10	mm
Width	22.00	±0.10	mm
Thickness	2.50	±0.20	mm
Weight	2.6	±0.5	g

a. Dimensions are accurate as of the release date of this document.

1. GNSS support is SKU-dependent.

The AirPrime WP7702 module is an LGA form factor device. All electrical and mechanical connections are made through the 239 Land Grid Array (LGA) pads on the bottom side of the PCB. (See [Figure 10-1](#) on page 99 for details.)

*Note: The following figure shows top / bottom views of the unlabeled module. For a label example, see [Figure 3-8](#) on page 55.*

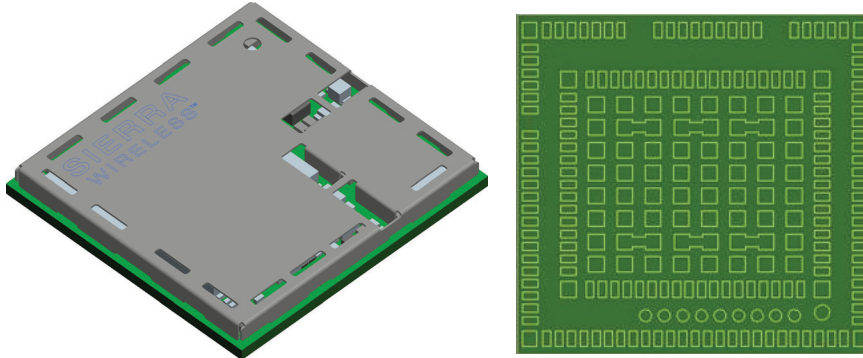

Figure 1-1: AirPrime WP7702 Mechanical Overview

The 239 pads have the following distribution:

**Table 1-4: LGA Pad Types**

Pad Type / Quantity		Dimensions	Pitch
Signal Pads	66 inner pads	1.0x0.5 mm	0.8 mm
	91 outer pads		
Test Points	1 polarity mark (Ground)	1.0 mm (diameter)	-
	9 test points	0.8 mm (diameter)	1.20 mm
Ground Pads	64 inner pads	1.0x1.0 mm	1.83 mm / 1.48 mm
	4 inner corner pads	1.0x1.0 mm	-
	4 outer corner pads	1.0x0.9 mm	-

## Related Documents

For additional documents and links related to the AirPrime WP7702 module, refer to [Appendix](#) on page 120.

# 2: Functional Specifications

## 2.1 Architecture

The following figures present overviews of the AirPrime WP7702 module's internal architecture and external interfaces.

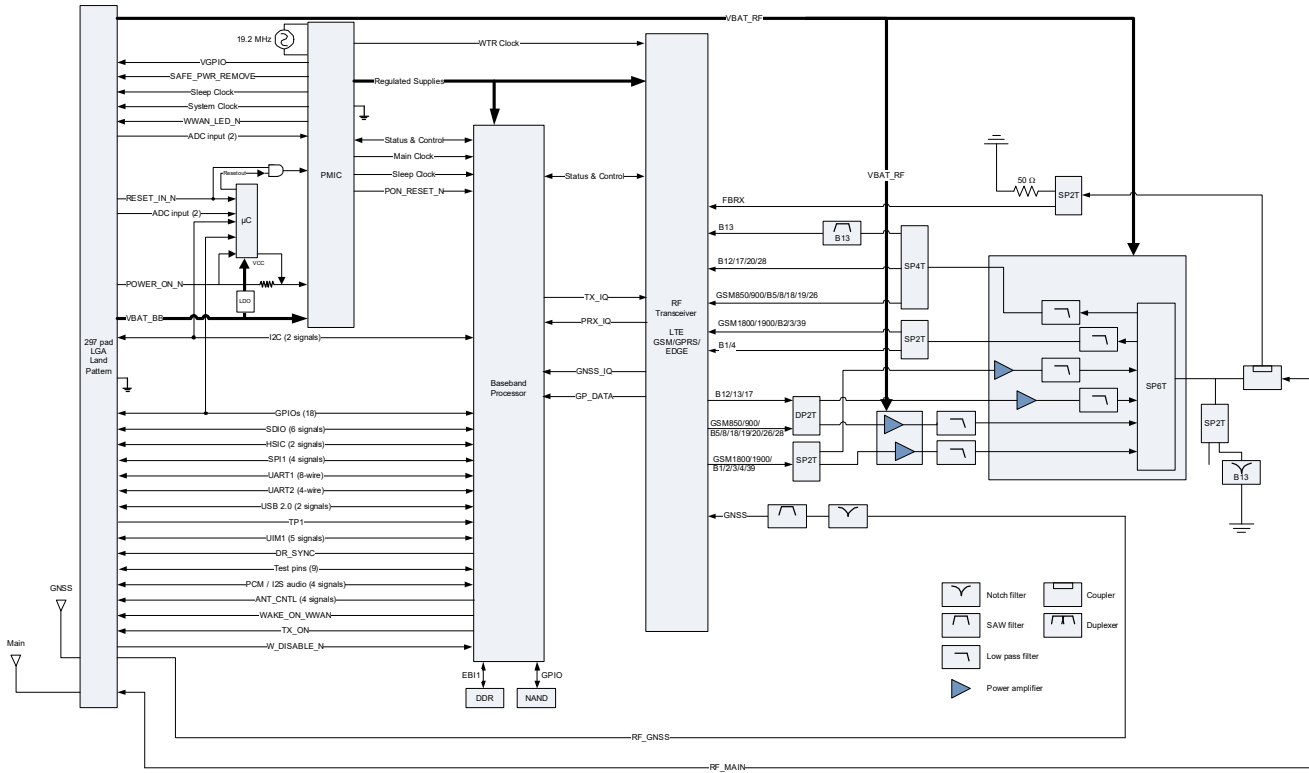

Figure 2-1: WP7702 Architecture Overview

## 2.2 Telecom Features

Table 2-1 summarizes the AirPrime WP7702 module’s capabilities offered through the Telecom core.

**Table 2-1: AirPrime WP7702 Capabilities**

Feature	Description
Electrical	3.4–4.3V supply voltage (VBAT_BB, VBAT_RF): <ul style="list-style-type: none"> <li>▪ Single supply (recommended), VBAT_BB tied to VBAT_RF <i>or</i></li> <li>▪ Dual supplies, single supply each for VBAT_BB and VBAT_RF</li> </ul>
SMS	<ul style="list-style-type: none"> <li>▪ SMS MO and MT</li> <li>▪ CS and PS support</li> <li>▪ SMS saving to UIM card or ME storage</li> <li>▪ SMS reading from UIM card or ME storage</li> <li>▪ SMS sorting</li> <li>▪ SMS concatenation</li> <li>▪ SMS Status Report</li> <li>▪ SMS replacement support</li> <li>▪ SMS storing rules (support of AT+CNMI, AT+CNMA)</li> </ul>

### 2.2.1 Network Technology Specifications

**Table 2-2: WP7702 RF Bands / Connectivity**

Technology	RF band	Transmit band (Tx) (MHz)	Receive band (Rx) (MHz)	Maximum output power
LTE	B1	1920–1980	2110–2170	23 dBm ± 1 dB Class 3
	B2	1850–1910	1930–1990	
	B3	1710–1785	1805–1880	
	B4 <sup>a</sup>	1710–1755	2110–2155	
	B5	824–849	869–894	
	B8	880–915	925–960	
	B12	699–716	729–746	
	B13	777–787	746–756	
	B17 <sup>b</sup>	704–716	734–746	
	B18	815–830	860–875	
	B19	830–845	875–890	
	B20	832–862	791–821	
	B26	814–849	859–894	
B28	703–748	758–803		

Table 2-2: WP7702 RF Bands / Connectivity (Continued)

Technology	RF band	Transmit band (Tx) (MHz)	Receive band (Rx) (MHz)	Maximum output power
GPRS/EDGE	GSM 850	824–849	869–894	32 dBm $\pm$ 1 dB; GMSK mode (Class 4; 2 W, 33 dBm)
				26.5 dBm $\pm$ 1 dB; 8PSK mode (Class E2; 0.5 W, 27 dBm)
	E-GSM 900	880–915	925–960	32 dBm $\pm$ 1 dB; GMSK mode (Class 4; 2 W, 33 dBm)
				26.5 dBm $\pm$ 1 dB; 8PSK mode (Class E2; 0.5 W, 27 dBm)
	DCS 1800	1710–1785	1805–1880	29 dBm $\pm$ 1 dB; GMSK mode (Class 1; 1 W, 30 dBm)
				25.5 dBm $\pm$ 1 dB; 8PSK mode (Class E2; 0.4 W, 26 dBm)
	PCS 1900	1850–1910	1930–1990	29 dBm $\pm$ 1 dB; GMSK mode (Class 1; 1 W, 30 dBm)
				25.5 dBm $\pm$ 1 dB; 8PSK mode (Class E2; 0.4 W, 26 dBm)
GNSS <sup>c</sup>	GPS	-	1575.42 $\pm$ 1.023	-
	GLONASS	-	1597.52–1605.92	-
	Galileo	-	1575.42 $\pm$ 2.046	-
	BeiDou	-	1561.098 $\pm$ 2.046	-

- a. B4 — CAT-M1 only  
b. B17 — CAT-NB1 only  
c. GNSS support is SKU-dependent.

### 2.2.1.1 GPRS/EDGE Specifications

The following table describes GPRS/EDGE specifications for WP7702 modules.

**Table 2-3: Supported GPRS / EDGE Specifications**

Standard	Feature Description
GPRS	Packet-switched data: <ul style="list-style-type: none"> <li>▪ GPRS Multislot class 10 (no backoff) — Four Rx slots (maximum), two Tx slots (maximum), five active slots total</li> <li>▪ Coding schemes—CS1–CS4</li> <li>▪ GEA1, GEA2, and GEA3 ciphering</li> <li>▪ SMS over GPRS</li> </ul>
EDGE	<ul style="list-style-type: none"> <li>▪ E2 power class for 8 PSK</li> <li>▪ EGPRS — Multislot class 12 (with backoff) — Four Rx slots (maximum), four Tx slots (maximum), five active slots total</li> <li>▪ GPRS/EDGE MSC12-EDA - permits allocation of more than two uplink timeslots for GPRS/EDGE</li> <li>▪ Coding schemes — MCS1–MCS9</li> <li>▪ BEP reporting</li> <li>▪ SRB loopback and test modes A and B</li> <li>▪ 8-bit and 11-bit RACH</li> <li>▪ PBCCH support</li> <li>▪ One-phase/two-phase access procedures</li> <li>▪ Link adaptation and IR</li> <li>▪ NACC, extended UL TBF</li> <li>▪ PFC/PFI (Packet Flow Context/Packet Flow Identifier) support - allows identity tagging of RLC blocks to identify separate QoS streams at the radio link layer</li> <li>▪ Enh DL RLC/MAC Segmentation - permits reception of MAC control messages that exceed one radio block capacity in length</li> <li>▪ Enhanced Ext UL TBF - dummy block transmission is punctured for current saving purposes</li> <li>▪ 2G PS handover - packet-switched equivalent of CS handover to ensure faster cell change and improved throughput</li> <li>▪ Band Scan: Run-time Configurable RRC Band Scan Order</li> <li>▪ Power and Network Optimizations: Frame Early Termination for Power Optimization</li> <li>▪ Protocols: MRAB-Pack-1 Enhancements - reduces multi-RAB call drops</li> <li>▪ Release 4 GERAN Feature Package 1 (NACC, extended uplink Temporary Block Flow (TBF))</li> <li>▪ Release 10 GPRS T3312 extended RAU periodic timer</li> <li>▪ Release 12 GPRS Power Save Mode</li> <li>▪ SAIC / DARP Phase 1</li> <li>▪ Latency reduction</li> <li>▪ Repeated FACCH, Repeated SACCH</li> <li>▪ A-GPS support</li> <li>▪ GPRS ROHC</li> <li>▪ Enhanced Operator Name String (EONS)</li> <li>▪ Enhanced Network Selection (ENS)</li> </ul>

## 2.2.1.2 LTE Specifications

The following table describes LTE specifications for AirPrime WP7702 modules.

**Table 2-4: Supported LTE Specifications**

Standard	Feature Description
R13	<ul style="list-style-type: none"> <li>▪ LPWA</li> <li>▪ Cat-NB1 Standalone, In-Band, and Guard-Band mode</li> <li>▪ Cat-NB1 Control Plane ClIoT EPS optimizations (Data over NAS)</li> <li>▪ eDRX (Extended Discontinuous Reception)</li> <li>▪ PSM (Power Saving Mode)</li> <li>▪ Cat M1 (Half-duplex (HD-FDD))— Uplink (375 kbps max), Downlink (300 kbps max), Tx power class 3 (23 dBm)</li> <li>▪ Cat M1— Extended Coverage Mode A</li> <li>▪ Cat NB1 (Half-duplex (HD-FDD))— Uplink (65 kbps max), Downlink (27 kbps max), Tx power class 3 (23 dBm)</li> <li>▪ RF Bandwidth (Rx): <ul style="list-style-type: none"> <li>• Cat M1— 1.08 MHz</li> <li>• Cat NB1— 180 kHz</li> </ul> </li> </ul>
R10	<ul style="list-style-type: none"> <li>▪ IPv6, QoS</li> <li>▪ NAS &amp; RRC standalone security</li> <li>▪ Commercial Mobile Alert System (CMAS)</li> <li>▪ ETWS (Earthquake Tsunami Warning System) notification</li> <li>▪ Inter-frequency/bandwidth mobility</li> <li>▪ DRX cycle while in: <ul style="list-style-type: none"> <li>• Connected mode</li> <li>• Idle mode</li> </ul> </li> <li>▪ UE IRAT support for Self Organizing Networks and Automatic Neighbor Relation (SON AR)</li> <li>▪ Attach/detach PS during SMS</li> <li>▪ GNSS positioning via LPP E-CID (LTE Positioning Protocol, Enhanced Cell ID)</li> </ul>
System Determination	<ul style="list-style-type: none"> <li>▪ Frequency Scan and System Selection within LTE</li> <li>▪ LTE BPLMN support</li> <li>▪ LTE Connected mode OOS</li> <li>▪ System selection across RATs (for details, see <a href="#">Radio Access Technology (RAT) Selection</a> on page 20), Standalone Security, Dedicated EPS Bearer Management and Dormancy</li> <li>▪ (WP7702 only) System selection across LTE, GERAN</li> <li>▪ 256 UPLMN and 256 OPLMN entries in UIM support</li> <li>▪ Carrier Specific BSR Requirements</li> </ul>
Data	<ul style="list-style-type: none"> <li>▪ Data call throttling</li> <li>▪ Default IPv4 bearer activation at attach/IPv4 data call</li> <li>▪ NW and UE initiated QoS</li> <li>▪ Dual IP and IPv4/IPv6 continuity</li> <li>▪ IPv4/IPv6 session continuity</li> <li>▪ W/G IP session continuity</li> <li>▪ Emergency services - LTE NAS Support for Control Plane LTE Positioning Protocol</li> </ul>

## 2.2.2 Radio Access Technology (RAT) Selection

Radio Access Technology (RAT) selection is the process a device employs to choose the RAT (e.g. LTE-M1, LTE-NB1, GSM) and associated radio frequency band to establish a network connection.

WP7702 modules support RAT selection through the use of the AT commands and API functions described in [Table 2-5](#).

To define the preferred network acquisition order and the set of radio frequency bands that the module will be able to operate on:

1. By default, the module searches for an available network from its Most Recently Used (MRU) list, then searches for available networks in the order shown by AT!SELACQ?.

*Note: The MRU enables a stationary (or relatively stationary) module to find its previous network quickly on subsequent power ups.*

If desired, change the RAT selection order:

- a. Use the following command:

```
AT!SELACQ=<mode1> [ , <mode2> [ , <mode3> [ , <mode4> ] ] ]
```

(e.g. AT!SELACQ=LTE-NB1 , GSM, LTE-M1 )

*Note: The AT command definition allows <mode4> and <mode5> parameters, however the WP7702 supports three RATs so <mode4> and <mode5> would never be used.)*

- b. Reset the module to make the new RAT selection order take effect.
2. Select the group of radio frequency bands that the module can operate on—use the AT!BAND command. Refer to [\[1\] AirPrime WPx5 / WP76xx / WP77xx AT Command Reference](#) for usage details.

*Note:*

- If the current network connection drops, the module automatically searches for a new network (which may use a different RAT). The module does not reboot when it changes to a different RAT.
- RAT switching occurs only when requested by the user or network provider, or when a network connection drops and a new network is acquired.
- When moving into an area without coverage for a given RAT, AT!SELACQ can be used to re-order the priority of the scanned RATs to avoid long scanning times. (For example, if an area is known to not have LTE-NB1 coverage, LTE-NB1 should be moved to the end of the list to prevent scanning for NB1 cells.)

**Table 2-5: RAT Selection-related Application User Interfaces**

Type	Interface <sup>a</sup>	Description
AT	!BAND	Choose either predefined groups of bands to scan (e.g. all bands, North American bands, etc.), or define a unique group of bands.
	+COPS	Initiate manual network scan. Use this to manually switch from one bearer to another.
	!SELACQ	Define the order in which the module searches for available RATs
	!SELCIOT	Set Cellular IoT (CIOT) operating mode preferences.

**Table 2-5: RAT Selection-related Application User Interfaces (Continued)**

Type	Interface <sup>a</sup>	Description
API	le_mrc_SetLTEBandPreferences()	Set the LTE RF band preference. Note that the bands selected by this command are not specific to LTE-M1 or LTE-NB1, therefore this command is only used to limit the bands scanned for both the LTE-M1 and LTE-NB1 networks.
	le_mrc_SetRatPreferences()	Force module to LTE (does not distinguish between LTE, M1, and NB1).

- a. For AT command details, refer to [1] AirPrime WPx5/WP76xx/WP77xx AT Command Reference from the device's page on [source.sierrawireless.com](http://source.sierrawireless.com). For API library function details, refer to the latest Legato Release Notes at [legato.io/legato-docs/latest/c\\_mrc.html](http://legato.io/legato-docs/latest/c_mrc.html).

## 2.2.3 Modem Specifications

**Table 2-6: Supported Modem Specifications**

Standard	Feature Description
Data	<ul style="list-style-type: none"> <li>▪ IPHC protocol as RFC 2509</li> <li>▪ Stateless DHCPv4 protocol to get P-CSCF and DNS addresses</li> <li>▪ IPv4/IPv6</li> <li>▪ Dual IP on single RmNet</li> <li>▪ Multi-RmNet Data Call</li> </ul>

## 2.3 Multi-Core Processing Capabilities

The AirPrime WP7702 is a powerful multiple-core system that includes:

- One QDSP6 core, embedding Telecom firmware with integrated data and wireless Internet connectivity
- One Cortex A7 core entirely dedicated to customer application and natively provided with Linux operating system

## 3: Technical Specifications

### 3.1 Environmental

The environmental specifications for operation and storage of the AirPrime WP7702 are defined in Table 3-1.

**Table 3-1: Environmental Specifications**

Parameter	Range	Operating Class
Ambient Operating Temperature	-30°C to +70°C	Class A
	-40°C to +85°C	Class B
Ambient Storage Temperature	-40°C to +85°C	-
Ambient Humidity	95% or less	-

Class A is defined as the operating temperature range within which the device:

- Shall exhibit normal function during and after environmental exposure.
- Shall meet the minimum requirements of 3GPP or appropriate wireless standards.

Class B is defined as the operating temperature range within which the device:

- Shall remain fully functional during and after environmental exposure
- Shall exhibit the ability to establish any of the device's supported call modes (SMS, Data, and emergency calls) at all times even when one or more environmental constraint exceeds the specified tolerance.
- Unless otherwise stated, full performance should return to normal after the excessive constraint(s) have been removed.

### 3.2 Power Supply Ratings

The AirPrime WP7702 operates using DC power supplied via the VBAT\_RF and VBAT\_BB signals. Power supply options are:

- (Recommended) A single regulated DC power supply (3.7V nominal)
- Two regulated DC power supplies (3.7V nominal), one each for VBAT\_BB and VBAT\_RF

*Note:*

- *Operation above the maximum specified operating voltage (see [Table 3-3](#) on page 23) is not recommended, and specified typical performance or functional operation of the device is neither implied nor guaranteed.*
- *The AirPrime WP7702 does not support operation using USB\_VBUS power.*

**Table 3-2: Power Supply Pins**

Pin	Name	Direction	Function	Notes
63, 158	VBAT_BB	Input	Baseband power supply	63 — Must be used 158 — Optional
61, 62, 157	VBAT_RF	Input	RF power supply	61/62 — Must be used 157 — Optional

**Table 3-3: Operating Conditions**

Parameter		Min	Typ	Max	Units	Notes
Power supply voltage <sup>a, b</sup>		3.4	3.7	4.3	V	Must be within min/max values over all operating conditions (including voltage ripple, droop, and transient).
Power supply ripple		-	-	100	mV <sub>pp</sub>	See <a href="#">Figure 3-1</a> on page 24.
Power supply voltage droop		-	-	250	mV	See <a href="#">Figure 3-1</a> on page 24 and <a href="#">Under-Voltage Lockout (UVLO)</a> on page 24.
Power supply voltage transient (overshoot/undershoot)		-	-	300	mV	See <a href="#">Figure 3-1</a> on page 24.
Supply current	LTE	-	0.8	1.5	A	<ul style="list-style-type: none"> <li>▪ Typical value varies and depends on output power, band, and operating voltage. See <a href="#">Current Consumption</a> on page 35 for values measured under normal operating conditions.</li> <li>▪ Max value measured over 100 μs period.</li> </ul>
	GSM	-	1.0	3.0	A	

- a. Power supply voltage outside the required range may affect call quality (dropped calls, data transfer errors, etc.).
- b. For Absolute Maximum Ratings, see [Table 3-22](#) on page 46.

Customer should characterize the ripple, droop, and transient response (overshoot/undershoot) of the power supply delivery system at the module input under full transmit power in GPRS/EDGE mode if supported, or LTE mode if not. To minimize voltage variation, add suitable capacitors to the supply line as close as possible to the module — depending on the power supply design, these capacitors may range from tens to several thousand μF.

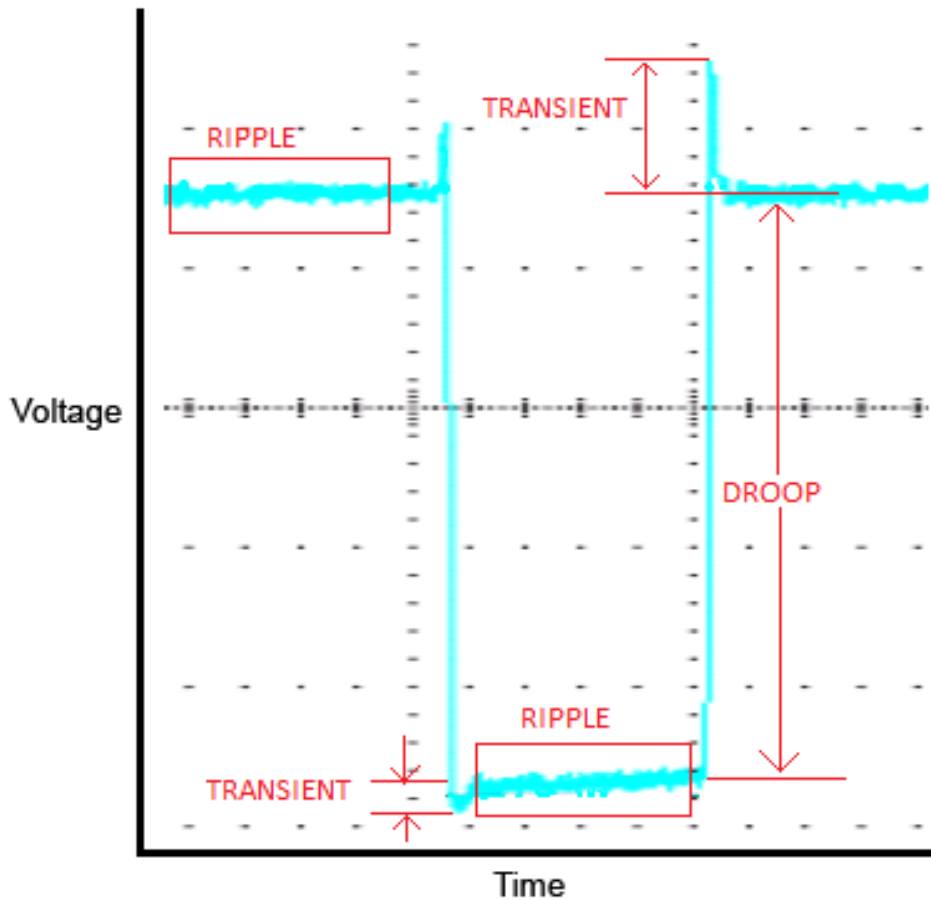

Figure 3-1: Power Supply Characteristics (capture enlarged)

### 3.2.1 Under-Voltage Lockout (UVLO)

The power management section of the AirPrime WP7702 includes an under-voltage lockout circuit that monitors supply and shuts down when VBAT\_BB falls below the threshold.

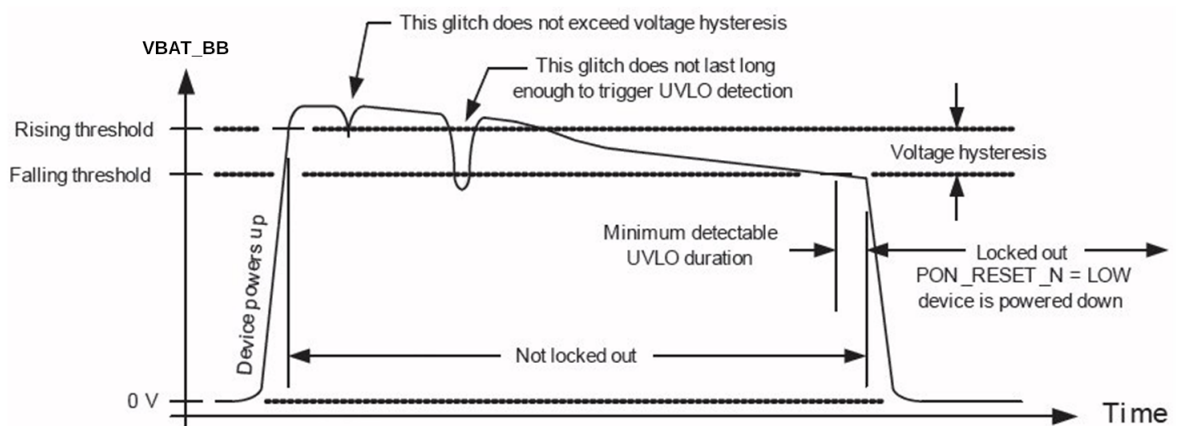

Figure 3-2: Under-Voltage Lockout (UVLO) Diagram

The AirPrime WP7702 will power down and remain off until VBAT\_BB returns to the valid range and the ON/OFF signal is active.

*Note: If the device experiences six consecutive UVLO events less than 45 seconds apart (approximately) and a host-initiated power down or reset has not occurred, the device enters a mode in which only the DM port enumerates on the USB.*

**Table 3-4: UVLO Specifications**

Parameter	Min	Typ	Max	Units
Threshold voltage, falling	2.225	2.4	2.80	V
Threshold voltage, accuracy	-5	-	+5	%
Hysteresis	-	425	-	mV
UVLO detection interval	-	1.0	-	μs

### 3.2.2 Power Consumption States

The AirPrime WP7702 has four basic power states (Active, Sleep, Ultra Low Power State (ULPS), and Off). As the module transitions between power states, the range of available device functionality adjusts appropriately, as described in [Table 3-5](#) on page 25 and [Figure 3-3](#) on page 29.

In the Active state, the module is ON with the application processor running. In Sleep state, the processor suspends its activity, reducing power consumption. The Active and ULPS states have more than one power mode each, to reduce power consumption. ULPS supports both Power Saving Mode (PSM, network-dependent) and Ultra Low Power Mode (ULPM), which may be enabled to achieve the lowest possible average power consumption.

**Table 3-5: Supported Power States**

State	Description
Active	<p>Module is fully powered (Linux can be run in the <a href="#">Application Core</a>; modem is on) and operating in one of the following modes:</p> <ul style="list-style-type: none"> <li>Full function mode (WWAN radio active; GNSS radio can be turned on/off) — Highest power consumption.</li> <li>Idle mode (WWAN radio on; Module registered on network, but no active connection; GNSS radio can be turned on/off)</li> <li>Airplane mode (WWAN radio off; GNSS radio can be active if allowed by PRI)</li> <li>eDRX (Extended Discontinuous Reception) — eDRX mode provides a ‘flexible sleep’ for the modem, which significantly reduces energy consumption. For eDRX details, see <a href="#">Extended Discontinuous Reception (eDRX)</a> on page 33.</li> </ul>
Sleep	<p>Lower power consumption than Active state, but higher than ULPS.</p> <ul style="list-style-type: none"> <li><a href="#">Application Core</a> is sleeping; modem is in DRX/eDRX. The processor monitors signals (triggers) that can ‘wake’ the module — see <a href="#">Wakeup Interrupt (Sleep State)</a> on page 63 for details.</li> </ul> <p>Sleep state can be entered based on USB-SS (if USB is connected to the module), UART_DTR, wake_lock(), configured GPIOs, and QMI exchanges from the modem.</p> <p><i>Note: On Windows systems, due to limitations of the Windows ECM driver, Sleep state is only supported if ECM is disabled or USB is disconnected.</i></p>

**Table 3-5: Supported Power States (Continued)**

State	Description
Ultra Low Power State (ULPS)	<p>ULPS is entered through either ULPM or PSM, and enables the module to attain its lowest power consumption by turning off the <a href="#">Application Core</a> processor (no applications will run) while waiting for wakeup sources ('boot sources'). When the module wakes from ULPS, the module reboots into the Active state.</p> <p>AUIs (Legato, Linux sysfs, and AT interface) are available to:</p> <ul style="list-style-type: none"> <li>• Configure wakeup sources (also known as boot sources)</li> <li>• Select ULPM, PSM, or PSM with ULPM fallback (when PSM is not supported by the network)</li> </ul> <p><b>Note:</b> <i>Some configuration options are not available in different AUIs (e.g. AT/sysfs allow selection of PSM, ULPM, and PSM with ULPM fallback, while Legato supports only PSM with ULPM fallback).</i></p> <p>Once a module is in ULPS, it remains in this state until woken by a wakeup source (see <a href="#">Table 3-6</a> on page 27).</p> <p>ULPS current consumption varies depending on configured triggers. For example, the lowest consumption occurs when the processor is waiting only for a timer (approximately 6 <math>\mu</math>A), and the highest consumption occurs when all supported triggers are configured.</p> <p><b>Note:</b> <i>Current consumption in both ULPM and PSM modes will be similar.</i></p> <p>For details on configuring ULPM, and how the module transitions between Active and ULPM states, see <a href="#">Active State to ULPS Transition</a> on page 32.</p>
	<p><b>Ultra Low Power Mode (ULPM)</b></p> <p>ULPM is an operational mode that allows the module to enter ULPS without any dependency on network support. AUIs (Legato, Linux sysfs, and AT interface) are first used to configure wakeup sources. Then, when the application uses an AUI to enable ULPM, the module detaches from the network (if currently attached) and enters ULPS.</p> <p>When a wakeup source triggers exit from ULPS, the modem and application processors boot up and the module reattaches to the network to resume operation in Active state until ULPM is again enabled by the application.</p> <p><b>Note:</b> <i>All interfaces connected to the module's GPIOs (see <a href="#">Table 4-6</a> on page 62) must be tri-stated or off to prevent additional leakage current during ULPM and potentially damaging the unit by applying a voltage when the GPIOs are off.</i></p>
	<p><b>LTE Power Saving Mode (PSM)</b></p> <p>3GPP Release 12 introduced network support of PSM. PSM allows the module to negotiate, with the network, an extended period during which registration context with the network is retained while the module is unreachable. During the negotiated period, the module enters ULPS.</p> <p>When a wakeup source triggers exit from ULPS, the modem and application processors boot up and the module sends a TAU (Tracking Area Update) to the network.</p> <p>After sending the TAU, the module remains active to allow any pending data to be exchanged with the network. Then, after a negotiated period of inactivity, the module automatically returns to ULPS to repeat the PSM cycle.</p> <p><b>Note:</b> <i>Wakeup sources are retained across PSM cycles, but may be changed by the application during the active period, if desired.</i></p> <p>For PSM details, see <a href="#">Power Saving Mode (PSM)</a> on page 30.</p>

**Table 3-5: Supported Power States (Continued)**

State	Description
	<p><b>Comparison — PSM vs. ULPM</b></p> <p>PSM differs from ULPM in the following ways:</p> <ul style="list-style-type: none"> <li>PSM is network-dependent (network must support 3GPP PSM), with a repeating cycle of an Active period and an inactive period, managed by the telecom stack. ULPM is network-independent, and each entry to ULPS is controlled by the application.</li> <li>PSM is subject to timer values negotiated with the network, including a 'TAU' wakeup timer (initially set by the module, then negotiated with and agreed to be the network) that is automatically managed by the telecom stack. ULPM may remain in ULPS indefinitely, waiting for non-time-based wakeup sources.</li> <li>In PSM, networking layer signaling overhead is reduced and context (such as IP address) is retained. Application data coming (downlink) from the network is queued for the next active period. Note that the processor can be woken by a wakeup source during the inactive period to send data without needing to reattach to the network.</li> <li>In PSM, radio resource signaling is reduced — TAU requires much less radio signaling than ULPM detach/reattach.</li> </ul>
OFF	<p>Module is OFF (no power to the system). Apply power for system to go to:</p> <ul style="list-style-type: none"> <li>Active state (POWER_ON_N is asserted) or</li> <li>ULPS (POWER_ON_N is de-asserted)</li> </ul>

**Table 3-6: ULPS Wakeup Sources**

Type	Description
PSM TAU timer	<p>Periodic TAU — PSM Cycle Timer (T3412) Configurable timer specifying PSM sleep duration. See <a href="#">Table 3-7</a> for configuration methods. Applies to PSM only.</p>
ULPS wakeup timer	<p>Timer that triggers after a specified period.</p> <ul style="list-style-type: none"> <li>ULPM — Optional</li> <li>PSM — Derived from TAU timer (value is automatically set slightly shorter than TAU timer to ensure module boot completes before TAU timer expires)</li> </ul>
ADC interrupt	<p>ADCs (ADC2, ADC3) configured for asynchronous wakeup of module. ADCs may be configured to trigger on threshold (above/below; e.g. wake on ADC2 above 1.2V) or range (inside/outside; e.g. wake when value is inside a specified range, or outside a specified range). Applies to both ULPM and PSM.</p> <hr/> <p><i>Note: Only one ADC at a time can be configured as a wakeup source. For example, if ADC3 is currently configured and then ADC2 is configured, the configuration for ADC3 is replaced by the ADC2 configuration.</i></p> <hr/>
GPIO interrupt	<p>Interrupt-capable GPIOs (GPIO36, GPIO38) configured for asynchronous wakeup of module. GPIOs may be configured to trigger on level transition (high/low) or edge transition (rising/falling/both). Applies to both ULPM and PSM.</p>

**Table 3-6: ULPS Wakeup Sources (Continued)**

Type	Description
RESET_IN_N	Resets the module with POWER_ON_N ON. Applies to both ULPM and PSM. <i>Note: If RESET_IN_N is used when POWER_ON_N is OFF, an emergency power off occurs — see <a href="#">Emergency Power Off</a> on page 58.</i>
POWER_ON_N	Wakes the module when asserted (transitions from OFF to ON). Applies to both ULPM and PSM.

Figure 3-3 on page 29 illustrates the current consumption requirements of the different power states and the possible transitions between power states. For specific values, see Table 3-9 on page 35.

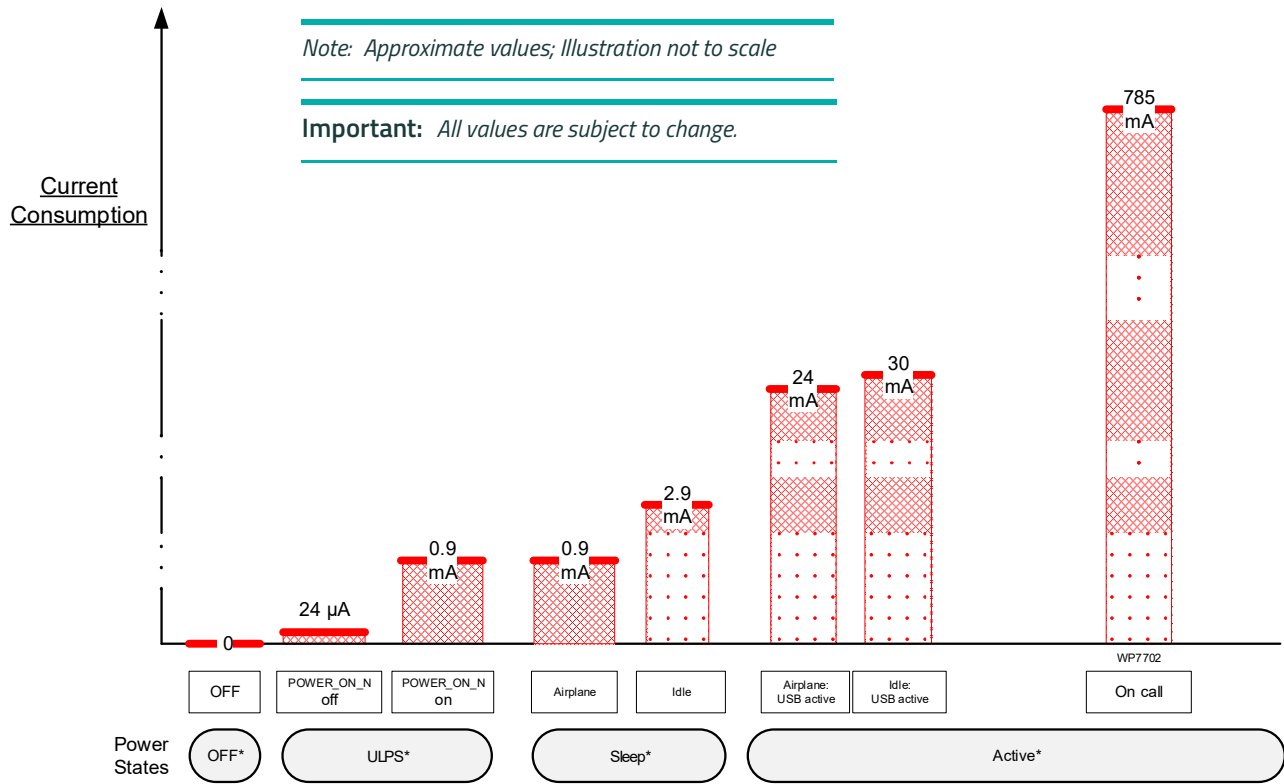

\* Refer to Table 3-5 for Power State definitions.

Transitions

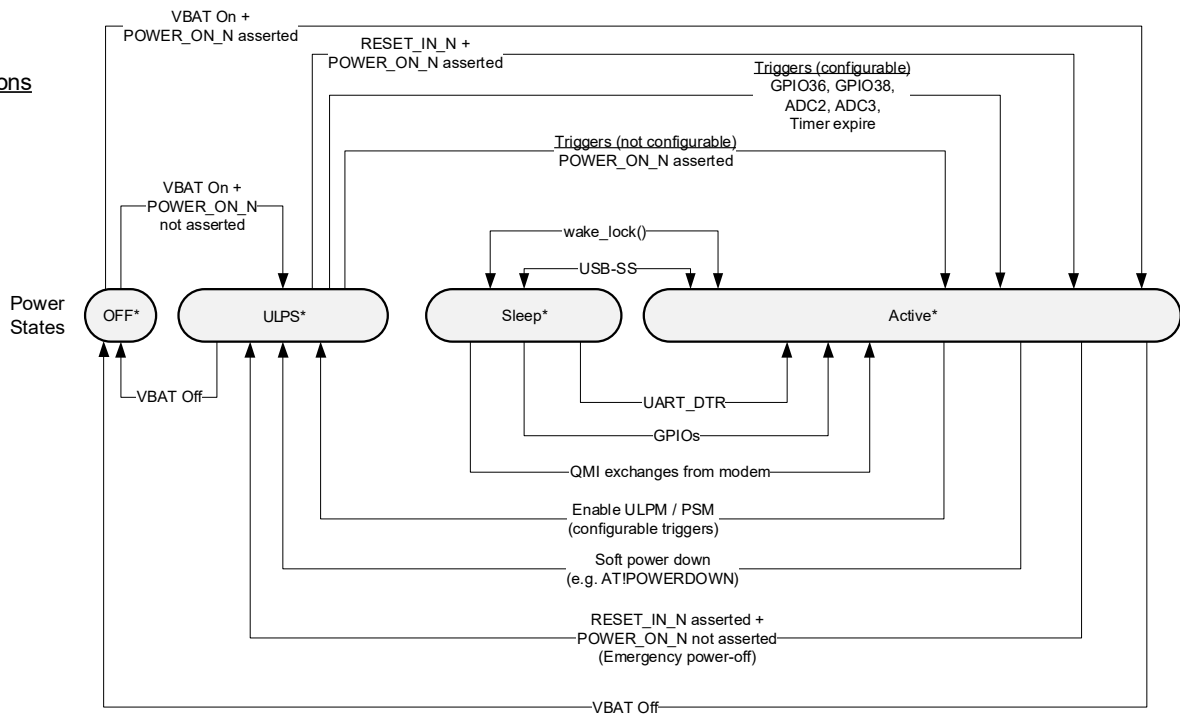

Note: VBAT = VBAT\_BB and VBAT\_RF

Figure 3-3: Power States Current Consumption and Transitions

### 3.2.3 Power Saving Mode (PSM)

Power Saving Mode (PSM) is a 3GPP feature that allows the WP7702 to minimize power consumption by registering on a PSM-supporting LTE network, entering ULPS (a very low power 'dormant' state) for a pre-configured duration (via a periodic TAU (Tracking Area Update) timer), and then booting up for a short period to transmit/receive data, before re-entering ULPS. During the dormant period, the module remains unreachable by the network until woken by a configured wakeup source (timer, ADC, GPIO, POWER\_ON\_N, RESET\_IN\_N) or the expiry of the periodic TAU timer.

*Note: When using PSM, the POWER\_ON\_N signal must be floating. If this signal is grounded, it will automatically trigger a wake.*

**Note:** Simplified current consumption pattern to illustrate general structure of PSM cycle power state transitions.

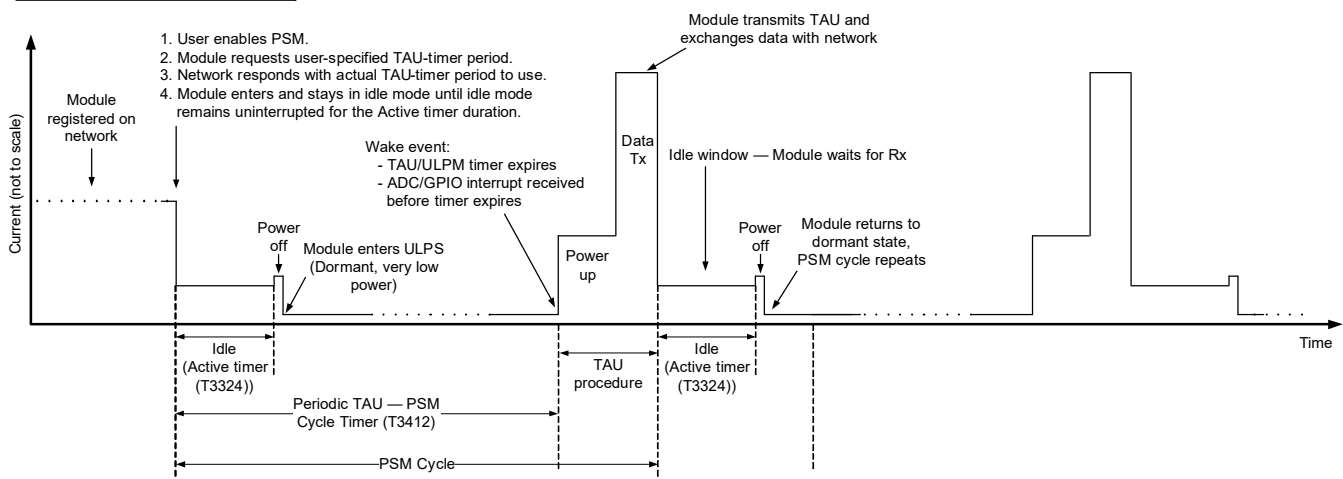

Figure 3-4: PSM Example (Simplified)

Typical candidates for PSM are systems (such as monitors and sensors) that:

- Require long battery life (low power consumption)
- Tolerate very long latency for mobile-terminated SMS/data
- Do not use mobile-terminated voice
- Send and/or receive data infrequently and periodically (e.g. on a given schedule of once every few hours, days, weeks, etc.)

For example, a module connected to a sensor can be configured to:

- Wake periodically to transmit collected data to a server or network entity (e.g. once per week schedule, or when a sensor activates an ADC interrupt due to an out-of-range reading), then
- Wait a short (configured) period of time to receive transmissions (e.g 60 seconds) and then return to ULPS.

Table 3-6 describes the available triggers for waking a WP7702 from ULPS. These triggers are configured using the methods described in Table 3-7.

**Table 3-7: ULPS-Related Application User Interfaces**

Type	Interface <sup>a</sup>	Description
AT	+CPSMS	<p>3GPP-defined command (3GPP TS27.007 Release 12) that allows direct control of all LTE PSM parameters, and is useful for advanced users wanting to test/experiment with different options. This command is limited to networks that support PSM.</p> <p>It is not expected that every user must be fully versed in the details of PSM to take advantage of its capabilities.</p> <p>Use this command to:</p> <ul style="list-style-type: none"> <li>▪ Enable/disable LTE PSM.</li> <li>▪ Configure Period TAU timer (T3412) with a requested maximum duration of the dormant period.</li> <li>▪ Configure Active timer (T3324) with a requested 'idle mode time' (the duration the module remains idle before going dormant)</li> <li>▪ For usage details, refer to [1] AirPrime WPx5/WP76xx/WP77xx AT Command Reference. (This command follows the 3GPP TS 27.007, Release 12 specification, with exceptions noted for certain parameters.)</li> </ul> <p><i>Note: The requested timer values are negotiated with the network and the final negotiated values take effect immediately, then persist across power cycles (e.g. after a power cycle, the settings will be used during network attach).</i></p>
	!POWERMODE	<p>Custom Semtech command that allows application developers to simplify the harmonization of PSM and ULPM without needing to consider whether PSM is supported on the network to which the WP module is currently attached.</p> <p>The command can be used to select the power mode (ULPM, PSM, PSM with ULPM fallback).</p> <p><i>Note: The Legato ulpm API provides equivalent functionality.</i></p>
	!POWERWAKE	<p>Custom Semtech command used to configure the wakeup sources for both PSM and ULPM, such as GPIOs, ADCs, and ULPS timer.</p> <p><i>Note: The Legato ulpm API provides equivalent functionality.</i></p>
	<p><b>Important:</b> Semtech recommends not combining use of +CPSMS and !POWERWAKE. These commands have some functional overlap, which may result in unexpected effects.</p>	
API	<p>Legato Power Services:</p> <ul style="list-style-type: none"> <li>▪ Power Manager</li> <li>▪ Ultra Low Power Mode</li> <li>▪ Boot Reason Query</li> </ul>	<p>Legato APIs and Linux sysfs nodes are available to configure and enable the feature.</p>

a. For AT command details, refer to [1] AirPrime WPx5/WP76xx/WP77xx AT Command Reference from the device's page on [source.sierrawireless.com](http://source.sierrawireless.com). For API library function details, refer to [docs.legato.io/latest/legatoServicesPowerMain.html](https://docs.legato.io/latest/legatoServicesPowerMain.html).

**Example: PSM process**

The following example describes how the module uses PSM (as shown in [Figure 3-4](#) on page 30):

1. Module registers on an LTE network.
2. User enables PSM via AT command or API library function, specifying the desired TAU timer and Active timer periods, and optional wakeup sources.

3. Module submits the PSM request (including desired TAU timer) to the network.
4. Network responds and indicates whether PSM is supported and (if it is) indicates the actual TAU timer to use.
5. If the network supports PSM:
  - a. Module enters idle mode (waiting for Rx from network).
  - b. When module has remained idle for the Active timer period, module powers off (except for maintaining timer and interrupts) and enters ULPS.
  - c. Module remains in ULPS for the specified period or until a configured trigger (ADC or GPIO interrupt, POWER\_ON\_N, RESET\_IN\_N) wakes it.

---

*Note: If traffic must be transmitted when the module is in the sleep portion of the cycle, the module can initiate data/SMS/voice session immediately.*

---

- d. Module powers up before TAU timer expires, then transmits TAU and/or exchanges data with network.
- e. Module enters idle mode and cycle repeats.

---

*Note: When the module is powered up, the PSM request can be re-issued with different timers and triggers to adjust the PSM behavior. These new settings take effect immediately.*

---

### Important notes

- Carefully select the PSM Periodic-TAU timer and Active Time values to match the intended use case(s) for the module:
  - Periodic TAU PSM Cycle timer (T3412) — Note that while the module is dormant (for the duration of this timer, unless woken by a user-configured ADC or GPIO interrupt, or POWER\_ON\_N or RESET\_IN\_N), it will be completely unreachable by the network.
  - Active Time (Idle mode time after transmission (T3324)) — Make sure to set the Active timer high enough to provide appropriate delay-tolerance for mobile-terminated/network-originated transmissions to be received.
- When using multiple devices, consider scheduling the modules to wake at different times so that the network does not get flooded by all modules waking and transmitting simultaneously.

## 3.2.4 Active State to ULPS Transition

If the module will be used in situations where it needs to be active very infrequently (for example, in a remote monitoring station that must transmit data periodically — e.g. on a regular schedule ranging from days to weeks or more), Ultra Low Power Mode (ULPM) or PSM (Power Saving Mode) may be used to reduce power consumption much more than is possible in Sleep state (low power active state):

1. Configure one or more supported wakeup sources that the processor will monitor while the module is in ULPS. See [Table 3-6, ULPS Wakeup Sources](#), on page 27.

---

*Note: Wakeup source configurations are persistent — if the module enters ULPS and then returns to Active power state, the configured triggers remain in effect.*

---

2. Initiate ULPM or PSM. The module will enter ULPS unless one or more of the configured wakeup sources is currently triggered. If the module does not enter ULPS, the request must be explicitly repeated — the module will not attempt to enter ULPS automatically.

### 3.2.5 Extended Discontinuous Reception (eDRX)

The WP7702 supports eDRX, which is a ‘flexible sleep’ active mode that allows for longer sleep duration ( $T_{C-eDRX}$ ,  $T_{I-eDRX}$ ) and a significant decrease in power consumption compared to regular DRX ( $T_{C-DRX}$ ,  $T_{I-DRX}$ ).

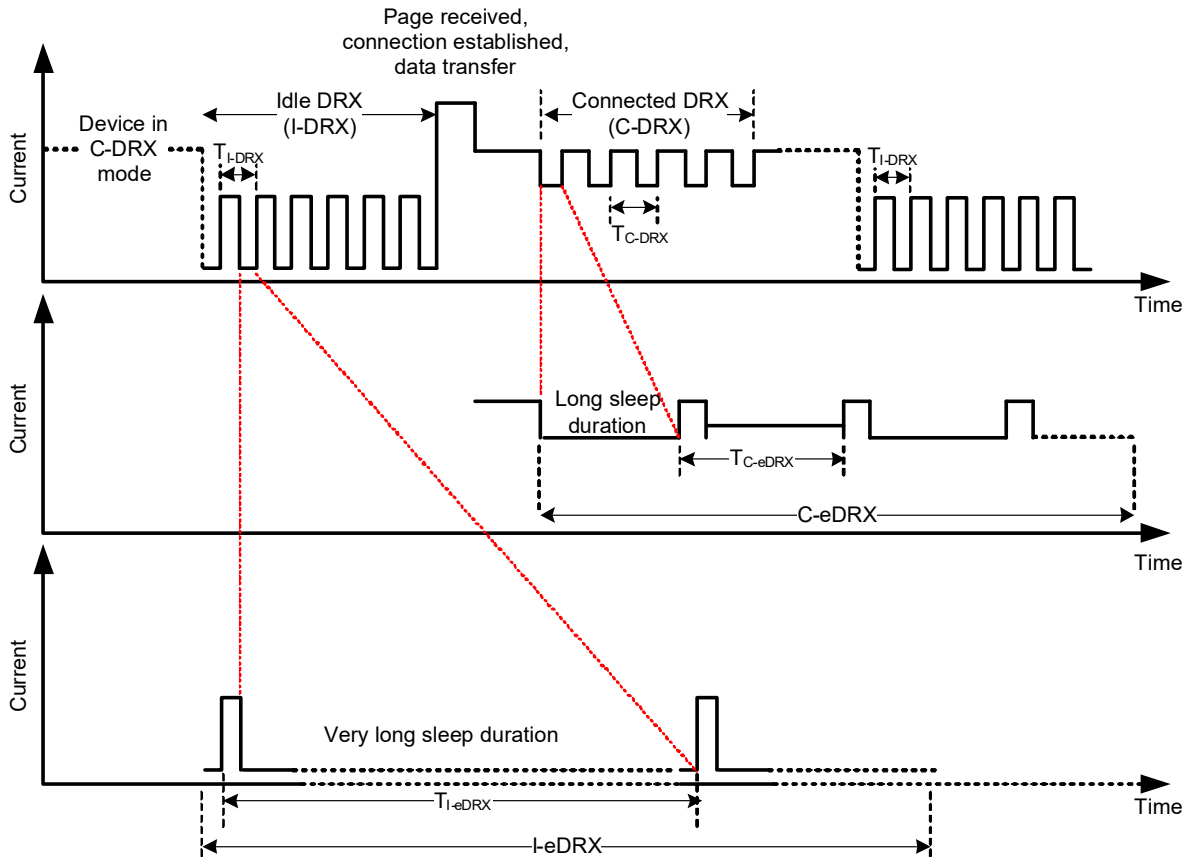

Figure 3-5: eDRX Example (Simplified)

Specifically, the WP7702 supports two forms of eDRX, both of which extend the DRX cycle (the paging cycle comprised of a paging window during which the module is awake and able to receive or transmit on the network, and a sleep period during which the network cannot wake the module) by increasing the sleep duration beyond the DRX maximum of 2.56 seconds:

- I-eDRX (Idle mode eDRX) — The sleep duration of the DRX cycle can be set up to 44 minutes for LTE-M, and up to 175 minutes for NB-IOT.  
(Note: I-eDRX has wider network support than C-eDRX.)
- C-eDRX (Connected mode eDRX) — The sleep duration of the DRX cycle can be set up to 10 seconds.

*Note: If traffic must be transmitted when the module is in the sleep portion of the cycle, the module can initiate data/SMS/voice session immediately.*

Table 3-8 describes the available methods for configuring eDRX.

**Table 3-8: eDRX-Related Application User Interfaces<sup>a</sup>**

Type	Interface	Description
AT	+CEDRXS	Enable/disable eDRX, and configure related settings
	+CEDRXRDP	Display eDRX values negotiated by the network
API	le_lpt_SetEDrxState()	Enable/disable eDRX
	le_lpt_SetRequestedEDrxValue()	Set eDRX cycle length for a specified RAT
	le_lpt_GetRequestedEDrxValue()	Get eDRX cycle length for a specified RAT
	le_lpt_GetNetworkProvidedEDrxValue()	Get eDRX cycle length provided by the network.
	le_lpt_GetNetworkProvidedPagingTimeWindow()	Get the paging window provided by the network (Note: The paging window cannot be set by the module.)
	le_lpt_AddEDrxParamsChangeHandler()	Set notifications for changes in network-provided eDRX parameters
	le_lpt_RemoveEDrxParamsChangeHandler()	Remove the handler.

a. For AT command details, refer to [1] AirPrime WPx5/WP76xx/WP77xx AT Command Reference from the device's page on [source.sierrawireless.com](http://source.sierrawireless.com). For API command details, refer to the latest Legato Release Notes at [legato.io/legato-docs/latest/c\\_mrc.html](http://legato.io/legato-docs/latest/c_mrc.html).

### Example: eDRX process

- Use the AT+CEDRXS command to configure the desired eDRX behavior.
- During the network attachment process:
  - eDRX request and settings are sent to the network
  - Network responds and indicates whether eDRX is supported for the connection and may adjust the eDRX parameters.
- If eDRX is supported by the network:
  - While in active mode (connected), the C-eDRX sleep duration is used if supported, otherwise the regular DRX sleep duration is used.
  - While in idle mode, the I-eDRX sleep duration is used if supported, otherwise the network uses the standard LTE I-DRX value.

### Important notes

- The sleep duration must be carefully selected to match the intended use case(s) for the module. While the module is asleep, it will be unreachable by the network. The duration should provide appropriate delay-tolerance for mobile-terminated/network-originated transmissions to be received.
- Due to the extended sleep time compared to regular DRX, eDRX is not suitable for most mobile-terminated voice connections.
- Network-side store and forward is supported — Packets will be stored until the module is reachable.

### 3.2.6 Current Consumption

The following tables describe the AirPrime WP7702 modules' current consumption under various power states. Typical values are measured at nominal supply voltage, nominal ambient temperature, and with a conducted 50Ω load on the antenna port.

**Table 3-9: WP7702 Current Consumption Values**

Mode	Parameter	Min	Typ <sup>a</sup>	Max <sup>b</sup>	Units
Power state— Active					
GPRS/EDGE data transfer	GSM 850	275	300	720 <sup>c</sup>	mA
	E-GSM 900	300	320	655	mA
	DCS 1800	225	235	555	mA
	PCS_1900	205	205	525	mA
GPRS/EDGE Peak current <sup>d</sup>	GSM 850/E-GSM 900	-	1.6 <sup>e</sup>	-	A
	DCS 1800/PCS_1900	-	1.1 <sup>e</sup>	-	A

Table 3-9: WP7702 Current Consumption Values (Continued)

Mode	Parameter		Min	Typ <sup>a</sup>	Max <sup>b</sup>	Units
LTE Data transfer <sup>f</sup>	B1	LTE-M1	60	285	785	mA
		LTE-NB1	60	120	515	mA
	B2	LTE-M1	60	255	590	mA
		LTE-NB1	60	110	455	mA
	B3	LTE-M1	60	265	630	mA
		LTE-NB1	60	115	480	mA
	B4 <sup>g</sup>	LTE-M1	60	285	675	mA
		LTE-NB1	60	120	500	mA
	B5	LTE-M1	60	265	625	mA
		LTE-NB1	60	120	545	mA
	B8	LTE-M1	65	290	745	mA
		LTE-NB1	60	125	560	mA
	B12	LTE-M1	60	290	520	mA
		LTE-NB1	60	105	430	mA
	B13	LTE-M1	60	270	645	mA
		LTE-NB1	60	130	615	mA
	B17 <sup>h</sup>	LTE-M1	n/a	n/a	n/a	n/a
		LTE-NB1	60	105	430	mA
	B18	LTE-M1	65	265	610	mA
		LTE-NB1	60	120	530	mA
	B19	LTE-M1	60	265	615	mA
		LTE-NB1	60	120	540	mA
	B20	LTE-M1	65	270	615	mA
		LTE-NB1	60	120	540	mA
	B26	LTE-M1	65	270	635	mA
		LTE-NB1	60	120	560	mA
	B28	LTE-M1	60	235	535	mA
		LTE-NB1	60	110	440	mA
Idle—GPRS/EDGE	<ul style="list-style-type: none"> <li>▪ Registered</li> <li>▪ MFRM=5</li> </ul>	USB active	22	29	30	mA
		No USB	2.3	2.7	3.3	mA

**Table 3-9: WP7702 Current Consumption Values (Continued)**

Mode	Parameter	Min	Typ <sup>a</sup>	Max <sup>b</sup>	Units	
Idle—LTE DRX	<ul style="list-style-type: none"> <li>▪ Registered</li> <li>▪ Paging cycle=2.56</li> </ul>	Cat M—USB active	22	26	27	mA
		Cat M—No USB	1.9	2.1	2.3	mA
		Cat NB—USB active	27	28	30	mA
		Cat NB—No USB	2.0	2.3	2.9	mA
Idle—LTE eDRX	Paging window—2.56 s	Cat M—No USB; Period—40.96 sec	1.3	1.4	2.0	mA
		Cat M—No USB; Period—5.46 min	1.3	1.4	1.5	mA
		Cat M—No USB; Period—44 min	0.95	-	-	mA
		Cat NB—No USB; Period—40.96 sec	1.1	1.8	2.5	mA
		Cat NB—No USB; Period—5.46 min	1.3	1.4	1.5	mA
		Cat NB—No USB; Period—175 min	0.95	-	-	mA
Airplane mode	Radio off	USB active	21	22	24	mA
		No USB	0.8	0.85	0.9	mA
Power state—Ultra Low Power mode (ULPM)						
See <a href="#">Table 3-10</a> on page 38 for details.						
Power state—Power Saving Mode (PSM)						
Non-active	Low power state	21.5 <sup>i</sup>	22 <sup>i</sup>	22.5 <sup>i</sup>	μA	
GNSS <sup>j</sup>						
GNSS	Acquisition (Airplane mode, cold start)	15	25	35	mA	
	Tracking (Registered)	15	25	35	mA	

- a. Typical, measured at nominal temperature, nominal voltage.
- b. Worst case, measured at 70°C, 3.4V.
- c. Max GPRS/EDGE values for four slots. Max current values displayed do not currently include data transfer.
- d. AT GPRS/EDGE conducted max Tx output power (see [Table 3-12](#) on page 39)
- e. Typical GPRS/EDGE values for one slot
- f. At LTE conducted max Tx output power (see [Table 3-14](#) on page 40)
- g. B4—CAT-M1 only
- h. B17—CAT-NB1 only
- i. PSM <sync> method 2 was used for measurements. See !POWERWAKE in [1] AirPrime WPx5/WP76xx/WP77xx AT Command Reference.
- j. GNSS current consumption values are for the GNSS radio only. For total consumption, add the GNSS value to the consumption for the mode being used.

Table 3-10 describes parameters that contribute to total current consumption while the module is in ULPS.

**Table 3-10: ULPS Current Consumption<sup>a</sup>**

Parameter		State	Value	Units
POWER_ON_N		Off (ULPM)	7	μA
		Off (PSM)	24 <sup>b</sup>	μA
		On	900	μA
Configured WP monitoring triggers	ULPS Wakeup timer	-	Insignificant	
	GPIO36 GPIO38 ADC2 <sup>c</sup> ADC3 <sup>c</sup>	Configured as open (default)	Insignificant	
		Other (Configured as closed and /or dependent on external circuitry design.)	≤ 50	μA

- a. All values are subject to change.
- b. PSM consumption value will be comparable to ULPM value in Release 11.
- c. Current consumption is affected by the interval between successive ADC measurements — longer intervals result in lower current consumption.

### 3.3 RF

This section presents the module’s WWAN RF interface, and defines the specifications for the LTE and GPRS /EDGE interfaces for supporting modules.

*Note: RF sensitivity values presented in this section are for soldered-down modules. Sensitivity values decrease for modules installed in snap-in sockets, which might prevent the module from meeting 3GPP minimum specifications.*

AirPrime WP7702 embedded modules are designed to be compliant with the standards in Table 3-11.

**Table 3-11: Standards Compliance**

Technology	Standards
LTE	<ul style="list-style-type: none"> <li>▪ 3GPP LTE Release 13</li> </ul>
EDGE/GPRS	<ul style="list-style-type: none"> <li>▪ 3GPP GSM Release 6</li> </ul>

### 3.3.1 GPRS/EDGE RF Interface

This section presents the GPRS/EDGE RF specification for AirPrime WP7702 modules.

#### 3.3.1.1 GPRS/EDGE Tx Output Power

The module's GPRS/EDGE maximum transmitter output power is specified in Table 3-12.

**Table 3-12: WP7702 Conducted Tx Max Output Power Tolerances — GPRS / EDGE<sup>a</sup>**

RF band	Min	Typ	Max	Units	Notes
GSM 850	31	32	33	dBm	GMSK mode (Class 4; 2 W, 33 dBm)
	25.5	26.5	27.5	dBm	8PSK mode (Class E2; 0.5 W, 27 dBm)
E-GSM 900	31	32	33	dBm	GMSK mode (Class 4; 2 W, 33 dBm)
	25.5	26.5	27.5	dBm	8PSK mode (Class E2; 0.5 W, 27 dBm)
DCS 1800	28	29	30	dBm	GMSK mode (Class 1; 1 W, 30 dBm)
	24.5	25.5	26.5	dBm	8PSK mode (Class E2; 0.4 W, 26 dBm)
PCS 1900	28	29	30	dBm	GMSK mode (Class 1; 1 W, 30 dBm)
	24.5	25.5	26.5	dBm	8PSK mode (Class E2; 0.4 W, 26 dBm)

a. Stated power tolerances satisfy 3GPP TS 51.010-1 requirements for normal (25 °C) and Class A (extreme) conditions.

#### 3.3.1.2 GPRS/EDGE Rx Sensitivity

The module's GPRS/EDGE receiver sensitivity is specified in Table 3-14.

**Table 3-13: WP7702 Conducted Rx Sensitivity — GPRS / EDGE Bands<sup>a</sup>**

Bands			Sensitivity @ +25 °C (dBm) <sup>b</sup>	Sensitivity @ Class A (dBm) <sup>c</sup>	Standard Limit (dBm)
GSM 850	10% BLER	GMSK CS1	-110	-108	-102
	10% BLER	EDGE MCS5	-101	-99	-98
EGSM 900	10% BLER	GMSK CS1	-109	-108	-102
	10% BLER	EDGE MCS5	-100	-99	-98
DCS 1800	10% BLER	GMSK CS1	-112	-111	-102
	10% BLER	EDGE MCS5	-103	-102	-98
PCS 1900	10% BLER	GMSK CS1	-112	-110	-102
	10% BLER	EDGE MCS5	-102	-101	-98

a. Stated sensitivity values satisfy 3GPP TS 51.010-1 requirements for normal (25 °C) and Class A (extreme) conditions.

b. Typical value

c. Typical value, tested at Class A extreme condition

### 3.3.2 LTE RF Interface

This section presents the LTE RF specification for AirPrime WP7702 modules.

#### 3.3.2.1 LTE Tx Output Power

The module’s LTE maximum transmitter output power is specified in the following tables.

**Table 3-14: WP7702 Conducted Tx Max Output Power Tolerances — LTE<sup>a</sup>**

RF band	Operating condition	Min	Typ	Max	Units	Notes
All Bands (B1, B2, B3, B4 <sup>b</sup> , B5, B8, B12, B13, B17 <sup>c</sup> , B18, B19, B20, B26, B28)	Normal (25°C)	22	23	24	dBm	Power class 3

- a. Stated power tolerances satisfy 3GPP TS 36.521-1 requirements for normal (25°C) and Class A (extreme) conditions.
- b. B4 —CAT-M1 only
- c. B17 —CAT-NB1 only

#### 3.3.2.2 LTE Rx Sensitivity

The module’s LTE receiver sensitivity is specified in the following tables.

**Table 3-15: WP7702 Conducted Rx Sensitivity — LTE-M1 Bands**

Band		@ +25°C (dBm) <sup>a</sup>	@ Class A (dBm) <sup>b</sup>	Worstcase <sup>c</sup>
B1	Full RB BW: 1.4 MHz	-106	-105	-102.7
B2		-106	-105	-100.3
B3		-106	-105	-99.3
B4		-106	-105	-102.3
B5		-105	-104	-100.8
B8		-105	-104	-99.8
B12		-106	-106	-99.3
B13		-104	-103	-99.3
B18		-105	-105	-100.3
B19		-105	-104	-102.3
B20		-107	-106	-99.8
B26		-105	-101	-100.3
B28		-107	-106	-100.8

- a. Typical value
- b. Typical value, tested at Class A extreme conditions
- c. Per 3GPP specification (ETSI TS 136 521-1 V13.3.0 (2016-2))

**Table 3-16: WP7702 Conducted Rx Sensitivity — LTE-NB1 Bands**

Band		@ +25 °C (dBm) <sup>a</sup>	@ Class A (dBm) <sup>b</sup>	Worstcase <sup>c</sup>
B1	Full RB BW: 12 subcarriers, 180 kHz	113.6	112.4	-108.2
B2		113.6	112.6	-108.2
B3		114.4	113.8	-108.2
B5		113.8	112.9	-108.2
B8		113.5	112.7	-108.2
B12		114.8	114.5	-108.2
B13		113.2	112.6	-108.2
B17		114.7	114.0	-108.2
B18		114.3	112.7	-108.2
B19		113.7	113.1	-108.2
B20		115.0	114.1	-108.2
B26		114.2	112.9	-108.2
B28		114.9	114.4	-108.2

- a. Typical
- b. Typical value, tested at class A and class B conditions
- c. Per 3GPP specification (ETSI TS 136 521-1 V13.3.0 (2016-2))

### 3.3.3 WWAN Antenna Interface

The following table defines the WWAN antenna interfaces of the AirPrime WP7702 modules.

**Table 3-17: WP7702 WWAN Antenna Interface Pins**

Pin #	Signal name	Direction	Function
48	GND		Primary Antenna Ground
49	RF_MAIN	Input/Output	Primary Antenna Interface
50	GND		Primary Antenna Ground
136	GND		Primary Antenna Ground
139	GND		Primary Antenna Ground

### 3.3.3.1 WWAN Antenna Recommendations

Table 3-18 defines the key characteristics to consider for antenna selection.

**Table 3-18: Antenna Recommendations<sup>a</sup>**

Parameter	Recommendations	Comments
Antenna system	External multi-band antenna system	
Operating bands	699-960	Operating bands depend on the module's supported bands / modes.
	1710-1990 MHz	
	2110-2170 MHz	
VSWR	< 2.5:1 (worst case)	On all bands including band edges
Total radiated efficiency	> 50% on all bands	<ul style="list-style-type: none"> <li>▪ Measured at the RF connector.</li> <li>▪ Includes mismatch losses, losses in the matching circuit, and antenna losses, excluding cable loss.</li> <li>▪ Semtech recommends using antenna efficiency as the primary parameter for evaluating the antenna system.</li> <li>▪ Peak gain is not a good indication of antenna performance when integrated with a host device (the antenna does not provide omnidirectional gain patterns). Peak gain can be affected by antenna size, location, design type, etc.</li> </ul>
Radiation patterns	Nominally omnidirectional radiation pattern in azimuth plane.	
Mean Effective Gain (MEG)	≥ -3 dBi	
Maximum antenna gain	Must not exceed antenna gains due to RF exposure and ERP/EIRP limits, as listed in the module's FCC grant.	
Maximum voltage applied to antenna	6.3 VDC	DC voltage
Power handling	> 2 W on all bands	<ul style="list-style-type: none"> <li>▪ Measure power endurance over 4 hours (estimated talk time) using a 2 W CW signal — set the CW test signal frequency to the middle of the PCS Tx band (1880 MHz for PCS).</li> <li>▪ Visually inspect device to ensure there is no damage to the antenna structure and matching components.</li> <li>▪ VSWR/TIS/TRP measurements taken before and after this test must show similar results.</li> </ul>

a. These worst-case VSWR figures for the transmitter bands may not guarantee RSE levels to be within regulatory limits. The device alone meets all regulatory emissions limits when tested into a cabled (conducted) 50 ohm system. With antenna designs with up to 2.5:1 VSWR or worse, the radiated emissions could exceed limits. The antenna system may need to be tuned in order to meet the RSE limits as the complex match between the module and antenna can cause unwanted levels of emissions. Tuning may include antenna pattern changes, phase/delay adjustment, passive component matching. Examples of the application test limits would be included in FCC Part 22, Part 24 and Part 27, test case 4.2.16 for GPRS/EDGE (ETSI EN 301 511), and test case 4.2.2 for WCDMA (ETSI EN 301 908-1), where applicable.

## 3.4 GNSS

The AirPrime WP7702 includes Global Navigation Satellite System (GNSS) capabilities via the QUALCOMM IZat™ Gen8C Engine (formerly gpsOne), capable of operation in assisted and standalone GNSS modes (GPS/Galileo/GLONASS/BeiDou).

*Note: AirPrime WP7702 modules are not affected by the 2019 GPS week rollover. Software modifications extend the GPS rollover date to 12 December 2032.*

### 3.4.1 GNSS Characteristics

The GNSS implementation supports GPS L1, Galileo E1, BeiDou-B1 and GLONASS L1 FDMA operation.

*Note: RF sensitivity values presented in this section are for soldered-down modules. Sensitivity values decrease for modules installed in snap-in sockets.*

**Table 3-19: GNSS Characteristics**

Parameter		Value
Sensitivity <sup>a</sup>	Standalone or MS-based tracking sensitivity	-160 dBm
	Cold start acquisition sensitivity	-145 dBm
	MS-assisted acquisition sensitivity	-156 dBm
Accuracy in open sky (1 Hz tracking)		< 2 m CEP-50
Satellite channels available <sup>b</sup>	Acquisition	118
	Simultaneous tracking	40
Support for predicted orbits		Yes
Predicted orbit CEP-50 accuracy		5 m
Standalone Time To First Fix (TTFF)	Hot	1 s
	Warm	29 s
	Cold	32 s
Altitude (max)		18,288 m (60,000 ft)
Velocity (max)		1,852 km/h (1150.8 mph)
Acceleration (max)		20 m/s <sup>2</sup>
GNSS message protocols		NMEA

- a. Acquisition/tracking sensitivity performance figures assume open sky with active patch GNSS antenna and a 2.5 dB system noise figure.
- b. Resources are dynamically assigned and not constellation-specific.

*Note:*

Note:

- Acquisition/tracking sensitivity performance figures assume open sky with active patch GNSS antenna and a 2.5 dB system noise figure.
- The WP7702 noise figure (without active antenna) is 4 dB, and the RF receiver intrinsic noise value is -170 dBm/Hz referenced to the receiver input.

### 3.4.2 GNSS Antenna Interface

The GNSS antenna interface is defined in [Table 3-20](#).

**Table 3-20: GNSS Antenna Interface Pads**

Pad	Name	Direction <sup>a</sup>	Function
37	GND		GNSS Antenna Ground
38	RF_GNSS	Input	GNSS Antenna Interface
39	GND		GNSS Antenna Ground
125	GND		GNSS Antenna Ground
128	GND		GNSS Antenna Ground

a. Signal direction with respect to the module.

#### 3.4.2.1 GNSS Antenna Recommendations

[Table 3-21](#) defines the key characteristics to consider for antenna selection.

**Table 3-21: GNSS Standalone Antenna Recommendations**

Parameter	Recommendations	Notes
Frequency range	<ul style="list-style-type: none"> <li>▪ Wide-band GPS, Galileo, GLONASS, and BeiDou: 1559–1606 MHz recommended</li> <li>▪ Narrow-band GPS: 1575.42 MHz ± 2.046 MHz minimum</li> </ul>	
Field of view (FOV)	<ul style="list-style-type: none"> <li>▪ Omni-directional in azimuth</li> <li>▪ -45° to +90° in elevation</li> </ul>	
Polarization (average Gv/Gh)	> 0 dB	Vertical linear polarization is sufficient.
Free space average gain (Gv+Gh) over FOV	> -6 dBi (preferably > -3 dBi)	Gv and Gh are measured and averaged over -45° to +90° in elevation, and ±180° in azimuth.
Gain	<ul style="list-style-type: none"> <li>▪ Maximum gain and uniform coverage in the high elevation angle and zenith.</li> <li>▪ Gain in azimuth plane is not desired.</li> </ul>	

**Table 3-21: GNSS Standalone Antenna Recommendations (Continued)**

Parameter	Recommendations	Notes
Average 3D gain	> -5 dBi	
Isolation between GNSS and RF Antenna	> 10 dB in all uplink bands	
Typical VSWR	< 2.5:1	
Polarization	Any other than LHCP (left-hand circular polarized) is acceptable.	Type of antenna and polarization (RHCP / linear) to be implemented is a matter of consideration based on specific end application.
Maximum voltage applied to antenna	6.3 VDC	DC voltage
700 MHz harmonic <sup>a</sup>	< -56 dBm (input jammer 787.76 MHz at -25 dBm and measure the harmonic tone at 1575.42 MHz)	This specification is for B13 coexistence.
IIP2 <sup>a</sup>	> 45 dBm (Input jammers at 824.6 MHz with level -25 dBm and 2400 MHz with level -32 dBm and measure output IM2 at 1575.4 MHz)	Out of band
IIP3 <sup>a</sup>	> 2 dBm (Input jammers at 1712.7 MHz with level -20 dBm and 1850 MHz with level -65 dBm and measure output IM3 at 1575.4 MHz)	Out of band
Input 1 dB power compression point <sup>a</sup>	> -10 dBm	
Out of band rejection for an active antenna		
777–798 MHz	> 50 dB	
814–915 MHz	> 40 dB	50 dB is preferred
925–960 MHz	> 30 dB	50 dB is preferred
1427–1463 MHz	> 35 dB	
1710–1785 MHz	> 35 dB	
1850–1980 MHz	> 40 dB	
2010–2025 MHz	> 40 dB	
2305–2315 MHz	> 40 dB	
2401–2483 MHz	> 40 dB	
2500–2570 MHz	> 35 dB	

a. For the LNA used by an active antenna

## 3.5 Electrical Specifications

This section provides details of the key electrical specifications of the AirPrime WP7702 embedded module.

### 3.5.1 Absolute Maximum Ratings

This section defines the absolute maximum ratings of the AirPrime WP7702.

**Warning:** *If these parameters are exceeded, even momentarily, damage may occur to the device. In addition, extended application of Absolute Maximum Rating conditions to the device may reduce device reliability.*

*Note: Operation above the maximum specified operating voltage (see [Table 3-3](#) on page 23) is not recommended, and specified typical performance or functional operation of the device is neither implied nor guaranteed.*

**Table 3-22: Absolute Maximum Ratings**

Parameter		Min	Typ	Max	Units
Power supply voltages					
VBAT_BB	Power Supply Input	0	-	6.0	V
VBAT_RF	Power Supply Input	0	-	5.5	V
VDD_Px (low-voltage (1.2V) operation)	Digital pad circuits	-0.5	-	1.44	V
VDD_Px (low-voltage (1.8V) operation)	Digital pad circuits	-0.5	-	2.3	V
VDD_Px (high-voltage (2.85V) operation)	Digital pad circuits	-0.5	-	3.35	V
USB signal pins					
USB_D+	High-speed USB data plus	-	-	3.6	V
USB_D-	High-speed USB data minus	-	-	3.6	V
USB_VBUS	High-speed USB bus voltage	-	-	5.25	V
Thermal conditions					
TS	Storage temperature	-40		85	°C
TJ	Junction temperature	-	-	130	°C
Maximum voltage applied to antenna interface pins					
VANT	RF_MAIN	-		6.3	Vdc
	RF_GNSS	-		6.3	Vdc
ESD ratings					
See <a href="#">EMC and ESD Recommendations</a> on page 83.					

## 3.5.2 Digital I/O Characteristics

The I/O characteristics for supported digital interfaces are described in:

- [Table 3-23](#) — HSIC signals
- [Table 3-24](#) — GPIOs (except GPIO8), UART, ANT\_CNTL, and TX\_ON signals
- [Table 3-25](#) — GPIO8
- [Table 3-26](#) — SDIO and UIM signals

**Table 3-23: Digital I/O Characteristics ( $V_{DD\_PX} = 1.20\text{ V}$  (nominal))**

Parameter		Comments	Min	Max	Units
$V_{IH}$	High level input voltage	CMOS/Schmitt	$0.65 * V_{DD\_PX}$	-	V
$V_{IL}$	Low level input voltage	CMOS/Schmitt	-	$0.35 * V_{DD\_PX}$	V
$I_{IH}$	Input high leakage current <sup>a</sup>	No pull-down	-	2	$\mu\text{A}$
$I_{IL}$	Input low leakage current <sup>b</sup>	No pull-up	-2	-	$\mu\text{A}$
$V_{OH}$	High level output voltage	CMOS, at pin-rated drive strength	$0.75 * V_{DD\_PX}$	-	V
$V_{OL}$	Low level output voltage	CMOS, at pin-rated drive strength	-	$0.25 * V_{DD\_PX}$	V
$I_Z$	Tri-state leakage current <sup>a</sup>	No pull, no keeper	-2	2	$\mu\text{A}$
$R_P$	Pull resistance	Pull-up and pull-down	17	60	$\text{k}\Omega$
$R_K$	Keeper resistance		17	60	$\text{k}\Omega$
$C_{IN}$	Input capacitance <sup>c</sup>		-	5	pF

a. Pin voltage =  $V_{DD\_PX}$  max.

b. Pin voltage = GND and supply =  $V_{DD\_PX}$  max.

c. Input capacitance and I/O capacitance values are guaranteed by design, but is not 100% tested.

**Table 3-24: Digital I/O Characteristics ( $V_{DD\_PX} = 1.80\text{ V}$  (nominal) signals)**

Parameter		Comments	Min	Max	Units
$V_{IH}$	High level input voltage	CMOS/Schmitt	$0.65 * V_{DD\_PX}$		V
$V_{IL}$	Low level input voltage	CMOS/Schmitt		$0.35 * V_{DD\_PX}$	V
$V_{SHYS}$	Schmitt hysteresis voltage		100	-	mV
$I_{IH}$	Input high leakage current <sup>a</sup>	No pull-down	-	1	$\mu\text{A}$
$I_{IL}$	Input low leakage current <sup>b</sup>	No pull-up	-1	-	$\mu\text{A}$
$R_P$	Pull up/down resistance		55	390	$\text{k}\Omega$
$V_{OH}$	High-level output voltage	CMOS, at pin-rated drive strength	$V_{DD\_PX} - 0.45$		V
$V_{OL}$	Low-level output voltage	CMOS, at pin-rated drive strength		0.45	V
$R_K$	Keeper resistance		30	150	$\text{k}\Omega$
$C_{IN}$	Input capacitance <sup>c</sup>		-	5	pF
$I_{PIN}$	Current per pin		-	16	mA

a. Pin voltage =  $V_{DD\_PX}$  max. For keeper pins, pin voltage =  $V_{DD\_PX}$  max - 0.45 V.

- b. Pin voltage = GND and supply =  $V_{DD\_PX}$  max. For keeper pins, pin voltage = 0.45 V and supply =  $V_{DD\_PX}$  max.
- c. Input capacitance is guaranteed by design, but is not 100% tested.

**Table 3-25: GPIO8 Digital I/O Characteristics ( $V_{DD\_PX} = 1.80$  V (nominal) signals)**

Parameter		Comments	Min	Max	Units
$V_{IH}$	High level input voltage	CMOS/Schmitt	$0.65 * V_{DD\_PX}$		V
$V_{IL}$	Low level input voltage	CMOS/Schmitt		$0.35 * V_{DD\_PX}$	V
$V_{OH}$	High-level output voltage	CMOS, at pin-rated drive strength	$0.8 * V_{DD\_PX}$		V
$V_{OL}$	Low-level output voltage	CMOS, at pin-rated drive strength		$0.2 * V_{DD\_PX}$	V
$R_P$	Pull up/down resistance		10	50	k $\Omega$
$R_K$	Keeper resistance		10	50	k $\Omega$
$I_{IH}$	Input high leakage current <sup>a</sup>	No pull-down	-	1	$\mu$ A
$I_{IL}$	Input low leakage current <sup>b</sup>	No pull-up	-1	-	$\mu$ A
$V_{SHYS}$	Schmitt hysteresis voltage		165	-	mV

- a. Pin voltage =  $V_{DD\_PX}$  max.
- b. Pin voltage = GND and supply =  $V_{DD\_PX}$  max.

**Table 3-26: Digital I/O Characteristics (Dual-voltage —  $V_{DD\_PX} = 1.80$  V / 2.85 V (nominal))**

Parameter		Comments	Min	Max	Units
Common to dual-voltage pads (1.8 V / 2.85 V)					
$R_P$	Pull resistance	Pull-up and pull-down	10	100	k $\Omega$
$R_K$	Keeper resistance		10	100	k $\Omega$
$V_{SHYS}$	Schmitt hysteresis voltage		100	-	mV
$C_{I/O}$	I/O capacitance		-	5	pF
Common to SDC pad and UIM pad at 2.85 V only					
$I_{IH}$	Input high leakage current	No pull-down	-	10	$\mu$ A
$I_{IL}$	Input low leakage current	No pull-up	-10	-	$\mu$ A
Common to UIM pads, 1.8V/2.85 V					
$V_{IH}$	High level input voltage	CMOS/Schmitt	$0.7 * V_{DD\_PX}$	$V_{DD\_PX} + 0.3$	V
$V_{IL}$	Low level input voltage	CMOS/Schmitt	-0.3	$0.2 * V_{DD\_PX}$	V
$V_{OH}$	High level output voltage	CMOS, at pin-rated drive strength	$0.8 * V_{DD\_PX}$	$V_{DD\_PX}$	V
$V_{OL}$	Low level output voltage	CMOS, at pin-rated drive strength	0	0.4	V
SDC pads at 2.85 V only					
$V_{IH}$	High level input voltage	CMOS/Schmitt	$0.625 * V_{DD\_PX}$	$V_{DD\_PX} + 0.3$	V
$V_{IL}$	Low level input voltage	CMOS/Schmitt	-0.3	$0.25 * V_{DD\_PX}$	V

**Table 3-26: Digital I/O Characteristics (Dual-voltage —  $V_{DD\_PX} = 1.80\text{ V} / 2.85\text{ V}$  (nominal)) (Continued)**

Parameter		Comments	Min	Max	Units
$V_{OH}$	High level output voltage	CMOS, at pin-rated drive strength	$0.75 * V_{DD\_PX}$	$V_{DD\_PX}$	V
$V_{OL}$	Low level output voltage	CMOS, at pin-rated drive strength	0	$0.125 * V_{DD\_PX}$	V
Common to SDC pad and UIM pad at 1.8 V only					
$I_{IH}$	Input high leakage current <sup>a</sup>	No pull-down	-	2	$\mu\text{A}$
$I_{IL}$	Input low leakage current <sup>b</sup>	No pull-up	-2	-	$\mu\text{A}$
SDC pads at 1.8 V only					
$V_{IH}$	High level input voltage	CMOS/Schmitt	1.27	2	V
$V_{IL}$	Low level input voltage	CMOS/Schmitt	-0.3	0.58	V
$V_{OH}$	High level output voltage	CMOS, at pin-rated drive strength	1.4	-	V
$V_{OL}$	Low level output voltage	CMOS, at pin-rated drive strength	0	0.45	V

a. Pin voltage =  $V_{DD\_Px}$  max

b. Pin voltage = GND and supply =  $V_{DD\_Px}$  max

### 3.5.3 Internal Device Frequencies

Table 3-27 summarizes the frequencies generated within the AirPrime WP7702. This table is provided for reference only to the device integrator.

**Table 3-27: Internal Device Frequencies**

Subsystem / Feature	Frequency	Units
Real Time Clock	32.768	kHz
I <sup>2</sup> C Interface	100	kHz
PMIC switching power supplies	1.6	MHz
Fundamental clock	19.2	MHz
PLL	<ul style="list-style-type: none"> <li>▪ PLL0: 800.0000</li> <li>▪ PLL1: 614.4000</li> <li>▪ PLL2: 480.0000</li> <li>▪ PLL3: 600.6000</li> <li>▪ PLL4: 576.0000</li> <li>▪ PLL5: 691.2000</li> <li>▪ PLL6: Varies (1.2 GHz max)</li> </ul>	MHz
SPI	38	MHz
USB	480	Mb/s

## 3.6 Processing

### 3.6.1 Application Core

The Application Core is based on a Cortex A7 32-bit RISC architecture core. It has the following main characteristics:

- Up to 1.3 GHz operation
- Cache:
  - L1: Instruction (32 kB) and Data (32 kB)
  - L2: 256 kB

The Application Core supports Legato™, an open source embedded platform built on Linux, which allows the simultaneous safe running of multiple applications.

Refer to [Interfaces Specification](#) on page 56 for the list of interfaces supported by this core.

### 3.6.2 Embedded Memory

The AirPrime WP7702 module includes Flash and RAM embedded memory as detailed in [Table 3-28](#).

**Table 3-28: Embedded Memory Details**

Type	Details	Size
Flash	Total	512 MB
	Reserved for Application processor	256 MB
	Minimum number of write cycles	100,000
RAM	Total	256 MB
	Reserved for Application processor	128 MB

The application processor memory is dedicated to the Legato platform, including:

- Linux kernel
- Root file system
- Application framework
- Customer applications

#### 3.6.2.1 Flash Memory

Flash memory is partitioned for use by various elements. Partitions mtd11–mtd13 can be used by the customer to install their custom Linux firmware, and mtd14 and mtd16 can be used to install custom Legato framework and custom Legato applications. The remaining partitions are reserved for internal use.

Partition: mtd0 ("sbl") Usage: System bootloader (Internal use)
Partition: mtd1 ("mibib") Usage: Internal use
Partition: mtd2 ("backup") Usage: Internal use

Partition: mtd3 ("security") Usage: Internal use
Partition: mtd4 ("persist") Usage: Internal use
Partition: mtd5 ("efs2") Usage: Internal use
Partition: mtd6 ("swifota") Usage: Internal use
Partition: mtd7 ("tz") Usage: Internal use
Partition: mtd8 ("devcfg") Usage: Internal use
Partition: mtd9 ("rpm") Usage: Internal use
Partition: mtd10 ("modem") Usage: Internal use
Partition: mtd11 ("boot") Usage: Linux bootloader
Partition: mtd12 ("boot") Usage: Linux kernel
Partition: mtd13 ("system") Usage: Linux Root File System
Partition: mtd14 ("lefwkro") Usage: Legato application framework
Partition: mtd15 ("swirw") Usage: Internal use
Partition: mtd16 ("userapp") Usage: Legato customer application
Partition: mtd17 ("reserved") Usage: Internal use
Partition: mtd18 ("slot2") Usage: Internal use
Partition: mtd19 ("slot1") Usage: Internal use
Partition: mtd20 ("slot0") Usage: Internal use

Figure 3-6: Flash Memory Partitions

Follow these instructions to display partition sizes and to determine whether a customer firmware will fit:

1. Connect to the WP module.

2. Use Linux command 'cat /proc/mtd'. Partition sizes are listed in the 'size' column.

```
root@swi-mdm9x28-wp:~# cat /proc/mtd
dev: size erasesize name
mtd0: 00280000 00040000 "sbl"
mtd1: 00280000 00040000 "mibib"
mtd2: 00680000 00040000 "backup"
mtd3: 00100000 00040000 "security"
mtd4: 00200000 00040000 "persist"
mtd5: 01180000 00040000 "efs2"
mtd6: 04f40000 00040000 "swifota"
mtd7: 00180000 00040000 "tz"
mtd8: 000c0000 00040000 "devcfg"
mtd9: 000c0000 00040000 "rpm"
mtd10: 02000000 00040000 "modem"
mtd11: 00100000 00040000 "aboot"
mtd12: 00f00000 00040000 "boot"
mtd13: 01e00000 00040000 "system"
mtd14: 008c0000 00040000 "lefwkro"
mtd15: 01900000 00040000 "swirw"
mtd16: 08300000 00040000 "userapp"
mtd17: 03680000 00040000 "reserved"
mtd18: 02180000 00040000 "slot_2"
mtd19: 02180000 00040000 "slot_1"
mtd20: 02180000 00040000 "slot_0"
```

3. When building an image, use the **swicwe** command to display the sizes of the image components to ensure that they can fit in the associated partitions. For example, using WP77xx Release 13 Linux/Yocto (linux-SWI9X06Y\_02.35.02.00.cwe) and Legato (legato-19.11.2.cwe) image components:

```
$ swicwe -P /mnt/j2p1/Engineering/Firmware/Releases/External/MDM9X06/Release13/components/yocto.cwe
Type      Size(Exclude Header)  Product  Compress  Version
*APPL    34443276              Y931    0         SWI9X06Y_02.35.02.00 5208b3 CARMD-EV-SIGN01 2020/06/09 23:58:41
HASH     6560                  9X06    0         SWI9X06Y_02.35.02.00 5208b3 CARMD-EV-SIGN01 2020/06/09 23:58:41
APBL     569366                9X06    0         SWI9X06Y_02.35.02.00 5208b3 CARMD-EV-SIGN01 2020/06/09 23:58:41
SYST     24117248              Y931    0         SWI9X06Y_02.35.02.00 5208b3 CARMD-EV-SIGN01 2020/06/09 23:58:41
APPS     9748502                9X06    0         SWI9X06Y_02.35.02.00 5208b3 CARMD-EV-SIGN01 2020/06/09 23:58:41

$ swicwe -P legato_19.11.2.cwe
Type      Size(Exclude Header)  Product  Compress  Version
*APPL    6554000               Y921    0         19.11.2 9c7a34e jenkins 2020/05/29 06:53:48
USER     6553600               9X28    0         19.11.2 9c7a34e jenkins 2020/05/29 06:53:48
```

Refer to the following table for component details.

**Table 3-29: Image Component Storage Details**

Component	Description	Partition Storage Location
APBL	Yocto lk bootloader	mtd11 ("aboot")
APPS	Yocto kernel	mtd12 ("boot")
SYST	Yocto RootFS	mtd13 ("system")
USER	Legato framework	mtd14 ("lefwkro")

### 3.6.2.2 RAM

To display the amount of RAM currently available for use by customer applications, connect to the WP module and use Linux command "cat /proc/meminfo".

The total available RAM for application usage is displayed as **MemAvailable**.

```
$ cat /proc/meminfo
MemTotal:      187236 kB
MemFree:       6136 kB
MemAvailable: 104772 kB
Buffers:      31924 kB
Cached:       67992 kB
SwapCached:   0 kB
Active:       67992 kB
Inactive:     62108 kB
Active(anon): 30212 kB
Inactive(anon): 2044 kB
Active(file): 37780 kB
Inactive(file): 60064 kB
Unevictable:  0 kB
Mlocked:     0 kB
SwapTotal:   0 kB
SwapFree:    0 kB
Dirty:       0 kB
Writeback:   0 kB
AnonPages:   30196 kB
Mapped:      13984 kB
Shmem:       2072 kB
Slab:        24920 kB
SReclaimable: 7212 kB
SUnreclaim:  17708 kB
KernelStack: 2728 kB
PageTables:  1608 kB
NFS_Unstable: 0 kB
Bounce:      0 kB
WritebackTmp: 0 kB
CommitLimit: 93616 kB
Committed_AS: 1097788 kB
VmallocTotal: 761856 kB
VmallocUsed: 40096 kB
VmallocChunk: 719868 kB
```

Semtech recommends that customer applications do not consume more than 55MB of RAM to provision for future expansion of the modem software, protocol stack and Legato framework in the next two years.

### 3.6.3 Recovery Mechanism

The AirPrime WP7702 has the capability to automatically detect and recover from various corruption scenarios (for example, corruption may occur when power is abruptly removed from the module).

Each time the device boots and the file system mounts successfully, a backup of the file system is stored (the device will retain several backups). If a file system corruption is detected, the stored backups are checked and the most recent good backup is automatically restored.

To avoid the potential for memory corruption, make sure to always follow the proper power off procedure before removing power from the module. (Figure 4-1 on page 57 illustrates the signal timing details for powering off the module.)

### 3.6.4 Secure Boot/Secure Debug

AirPrime WP7702 modules incorporate the following permanently enabled features to enhance device security:

- Secure Boot—Ensures only firmware images signed by Semtech can be loaded and run on WP7702 modules. Specifically, Secure Boot applies to the following firmware components: system boot loader, carrier configuration, and telecom FW.
- Secure Debug—Disables debug features such as RAM dump collection and JTAG access to the module.

For additional details, refer to the WP Series Secure Boot and Secure Debug application notes available on [source.sierrawireless.com](http://source.sierrawireless.com).

### 3.7 Mechanical Drawing

The AirPrime WP7702 module's LGA footprint is a 239-pad array of copper pads (see [Physical Dimensions and Connection Interface](#) on page 13). The following drawing illustrates the device footprint and dimensions.

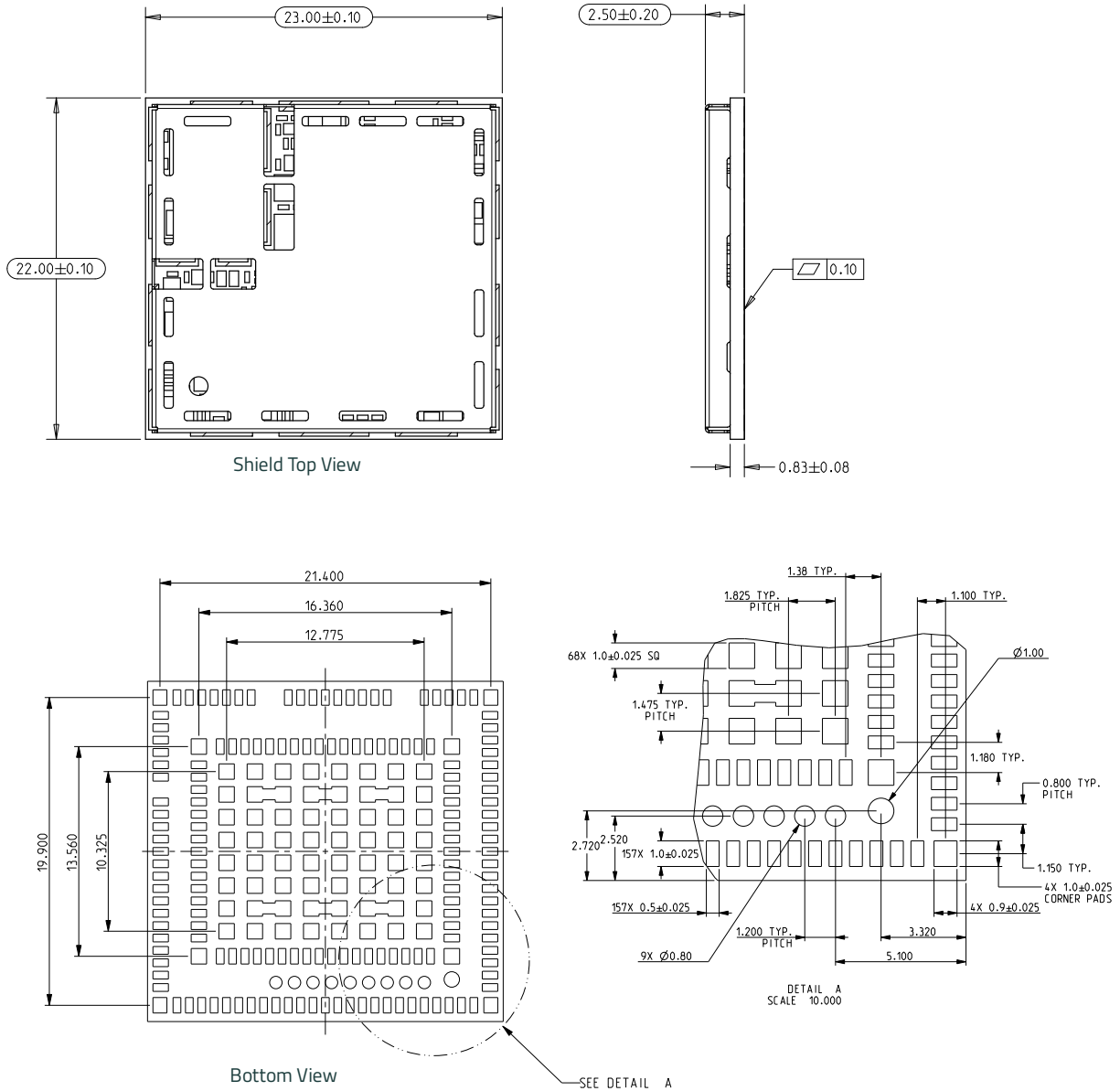

Figure 3-7: AirPrime WP7702 Mechanical Drawings

## 3.8 Labeling

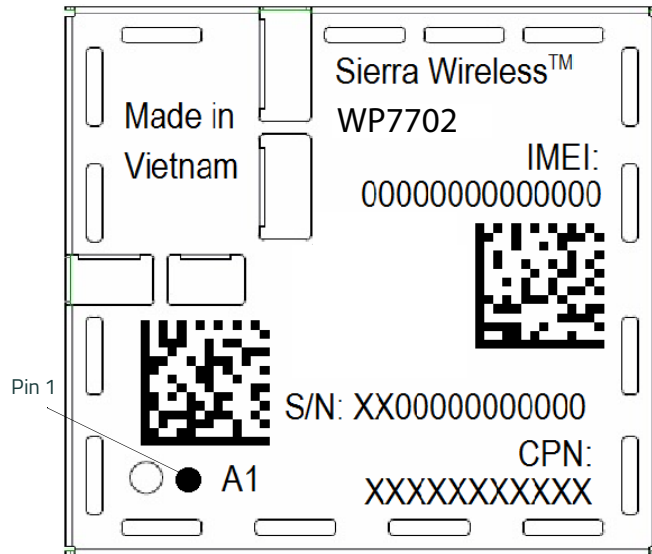

Figure 3-8: Unit Label, Typical Representation (Contents will vary by SKU)

The AirPrime WP7702 label is laser-etched and may contain:

- Product identification (Model name, serial number)
- IMEI or MEID number and barcode
- Fabrication country
- Pin 1 indicator

*Note: The AirPrime WP7702 supports OEM partner specific label requirements.*

# 4: Interfaces Specification

## 4.1 Overview

This section describes the interfaces supported by the AirPrime WP7702 embedded module and provides specific voltage, timing, and circuit recommendations for each interface.

## 4.2 POWER\_ON\_N

The AirPrime WP7702 module requires a low level signal (POWER\_ON\_N) that is used to switch the module ON.

The signal is connected internally to the permanent 1.8V supply regulator inside the module via a pull-up resistor. Once VBAT\_BB is supplied to the module, this 1.8V supply regulator will be enabled and so the POWER\_ON\_N signal is by default at high level.

---

**Important:** Use a momentary switch to control this line to reduce leakage current in ULPS. Holding POWER\_ON\_N low in ULPS incurs a significant current draw—see [Table 3-10](#) on page 38 for details.

---

[Table 4-1](#) describes the POWER\_ON\_N signal's characteristics.

**Table 4-1: POWER\_ON\_N Electrical Characteristics<sup>a</sup>**

Parameter	Min	Typ	Max	Units
Input Voltage— Low	0.35	-	0.67	V
Internal pull-up resistor	150	200	250	k $\Omega$

a. When floating, voltage will be approximately 800 mV.

### 4.2.1 Power-up Sequence

#### 4.2.1.1 Power On/Off Timing

Figure 4-1 describes the timing sequence for powering the module on and off.

---

*Note:* Before reaching the "Active" state, signals on the host port are considered to be undefined and signal transitions may occur. This undefined state also applies when the module is in reset mode, during a firmware update, or during the Power-off sequence. The host must consider these undefined signal activities when designing the module interface.

---

Note: The host should not drive any signals to the module until > 100 ms from the start of the power-on sequence.

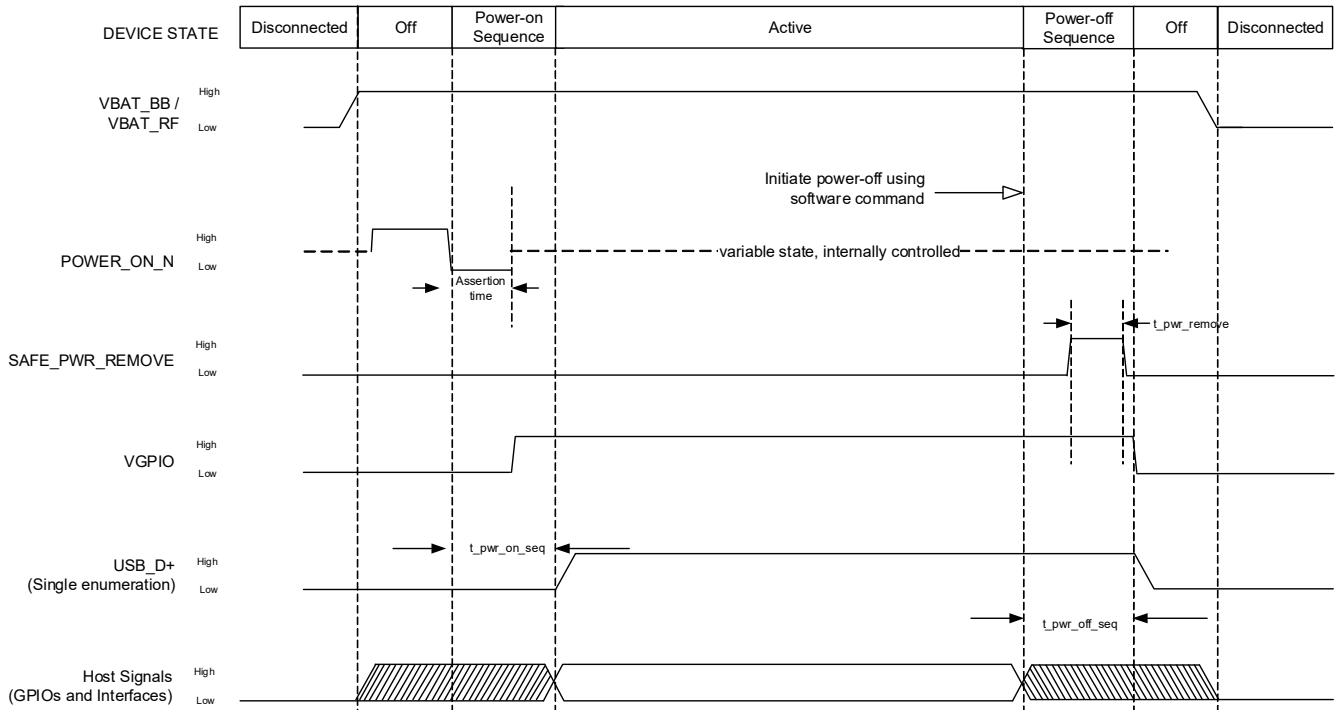

Figure 4-1: Signal Timing (POWER\_ON\_N, and USB Enumeration)

Table 4-2: POWER\_ON\_N Timing Parameters

Parameter	Minimum	Typical	Maximum	Units
$t_{pwr\_on\_seq}$	-	14.5	15.5	s
$t_{pwr\_off\_seq}$	-	0.4–5.5	6	s
$t_{pwr\_remove}$	-	13	-	ms
Assertion time <sup>a</sup>	200	-	-	ms

a. Assertion time is the time required to keep POWER\_ON\_N at LOW level to ensure the module can be powered ON successfully.

### 4.2.1.2 USB Enumeration

The unit supports single USB enumeration with the host. Enumeration starts within (maximum)  $t_{pwr\_on\_seq}$  seconds of power-on.

### 4.2.2 Software-Initiated Power Down

To power down the module via software:

1. Initiate the power down process:  
**AT+POWERDOWN**
2. Monitor VGPIO.
3. When VGPIO is low, remove power.

## 4.3 Emergency Power Off

The module can be switched off by controlling the RESET\_IN\_N pin. This must only be used in emergency situations if the system freezes (not responding to commands).

To perform an emergency power off:

1. De-assert POWER\_ON\_N.
2. While POWER\_ON\_N is de-asserted, assert RESET\_IN\_N (logic low) for at least 8 s. This immediately powers down the module.

## 4.4 Tx Power Control

The module's Tx power limit may be controlled using the following methods:

- SAR backoff AT commands (see [1] AirPrime WPx5/WP76xx/WP77xx AT Command Reference):
  - !SARSTATEDFLT — Set (or report) the default SAR backoff state that the device uses when it powers up. This setting is persistent across power cycles and overrides any PRI setting.
  - !SARSTATE — Set (or report) the current SAR backoff state (override the default state). This change in state is non-persistent across power cycles.
  - !SARBACKOFF — Set (or report) the maximum Tx power limit for a specific band / technology / state combination.
- Legato API library functions:
  - le\_mrc\_GetSarBackoffState() — Get the current SAR Backoff state.
  - le\_mrc\_SetSarBackoffState() — Set the current SAR Backoff state (override the default state). This change is non-persistent across power cycles.
- GPIO control via !SARGPIO command (see [1] AirPrime WPx5/WP76xx/WP77xx AT Command Reference) — Set an unallocated external GPIO to control SAR.

## 4.5 USB

The AirPrime WP7702 implements a high-speed USB2.0 Interface, which conforms to the *Universal Serial Bus Specification, Revision 2.0*.

Table 4-3 on page 58 describes the signals used for the USB interface.

See [USB Interface](#) on page 83 for a reference USB schematic.

**Table 4-3: USB Pin Descriptions**

Pin	Signal name	Direction <sup>a</sup>	Function
12	USB_D-	Input/Output	Differential data interface negative
13	USB_D+	Input/Output	Differential data interface positive
16	USB_VBUS	Input	USB supply voltage
91	USB_ID	Input	Used for USB_OTG

a. Signal direction with respect to the module. Example: USB\_ID is an input to the module from the host.

## 4.6 UART

The AirPrime WP7702 provides two UART interfaces:

- UART1 (primary UART) — 4-wire interface (Software support for 8-wire UART1 will be added in a future firmware revision.)
- UART2 (secondary UART) — 4-wire interface

The UART interfaces are used for data communication between the AirPrime WP7702 module and a PC or host processor. These interfaces comply with the RS-232 interface.

Flow control is managed using the RTS/CTS signals.

Table 4-4 on page 59 describes the signals used for UART1 and UART2.

*Note: UART signals are named with respect to the host device, and directions are listed with respect to the module. For example, UART1\_RX is an output from the module to the host.*

**Table 4-4: UART Pins**

Pin	Interface	Name <sup>a</sup>	Direction <sup>b</sup>	Function	If unused
2	UART1	UART1_RI <sup>d f</sup>	Output	Ring Indicator Signal incoming data, SMS, etc.	Leave open
3		UART1_RTS	Input	Ready To Send, flow control	Leave open <sup>c</sup>
4		UART1_CTS	Output	Clear To Send, flow control	Leave open
5		UART1_TX	Input	Transmit Data	Leave open
6		UART1_RX	Output	Receive Data	Leave open
7		UART1_DTR <sup>d e</sup>	Input (active low)	Data terminal ready <ul style="list-style-type: none"> <li>▪ When low (active), prevents the WP7702 from entering Sleep state. When high (not active), Sleep state is allowed (but not forced).</li> <li>▪ Switches between data mode and command mode</li> <li>▪ Wakes the module.</li> </ul>	Leave open
8		UART1_DCD <sup>d f</sup>	Output	Data Carrier Detect Signal data connection in progress	Leave open
9		UART1_DSR <sup>d f</sup>	Output	Data Set Ready Signal UART interface is ON	Leave open
96		UART2	UART2_TX	Input	Transmit data
97	UART2_RX		Output	Receive data	Leave open
98	UART2_RTS		Input	Ready To Send, flow control	Leave open
99	UART2_CTS		Output	Clear To Send, flow control	Leave open

- Signals are named with respect to the host device. For example, UART1\_RX is the signal used by the host to receive data from the module.
- Signal direction with respect to the module. For example, UART1\_RX is an output from the module to the host.
- If UART1 is implemented as a 2-wire interface, UART1\_RTS should be pulled low to disable flow control.
- Software support for 8-wire UART1 will be available in a future firmware revision.

- e. Pin is 'wakeable'. Can be used to trigger the module to wake up from USB-SS mode (low power active state). See [Wakeup Interrupt \(Sleep State\)](#) on page 63 for details.
- f. Do not install external pull-up on this pin, otherwise the module will not boot.

## 4.7 UIM Interface

The AirPrime WP7702 has one physical UIM interface — UIM1.

The interface allows control of external 1.8V/3V UIMs.

[Table 4-5](#) on page 60 describes the signals used for UIM1.

**Table 4-5: UIM Interface Pins**

Pin	Interface	Name	Direction <sup>a</sup>	Function	If Unused
26	UIM1	UIM1_VCC	Output	Supply output	Leave open
27		UIM1_CLK	Output	Clock	Leave open
28		UIM1_DATA	Input/Output	Data connection	Leave open
29		UIM1_RESET_N	Output	Reset	Leave open
64		UIM1_DET	Input	Detect UIM	Leave open

- a. Signal direction with respect to the module. Examples: UIM1\_DET (pin 64) is an input to the module from the host; UIM1\_RESET\_N (pin 29) is an output from the module to the host.

[Figure 4-2](#) illustrates the recommended implementation of a UIM holder. (For a more detailed UIM schematic, see [Figure 5-4](#) on page 85.)

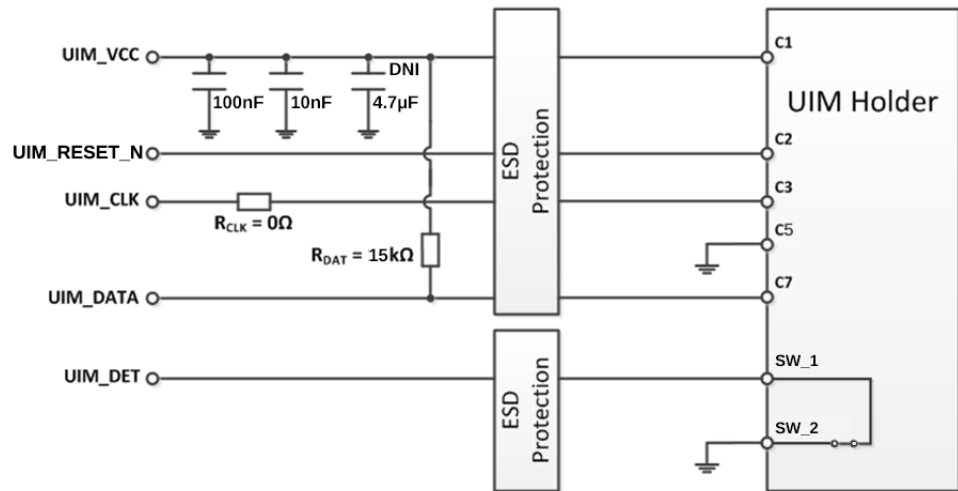

*Figure 4-2: Recommended UIM Holder Implementation*

The UIM Detect signal (UIM1\_DET) is used to detect the physical presence of a UIM card in the UIM holder. The signal has a pull-up internal to the AirPrime WP7702. It should be set to GND when a UIM is not present. All signals near the UIM holder must be ESD-protected.

The UIM Detect signal transitions:

- When a UIM is inserted — high (logic 0 to logic 1)
- When a UIM is removed — low (logic 1 to logic 0)

The capacitor and the two resistors, RCLK and RDATA, should be added as placeholders to compensate for potential layout issues. UIM\_DATA trace should be routed away from the UIM\_CLK trace. Keep the distance between the module and the UIM holder as short as possible.

An ESD device specifically designed for UIM cards is recommended for the UIM1 VCC, RESET\_N, CLK, and DATA signals (for example, STMicroelectronics DALC208SC6). For UIM1\_DET a low leakage ESD suppressor should be selected.

## 4.8 General Purpose Input/Output (GPIO)

The AirPrime WP7702 defines several GPIOs for customer use, as described in [Table 4-6](#). For electrical specifications, see [Table 3-24, Digital I/O Characteristics \(VDD\\_PX = 1.80 V \(nominal\) signals\)](#), on page 47.

---

*Note: In ULPM, all interfaces connected to GPIOs (see [Table 4-6](#) on page 62) must be tri-stated or off to prevent additional leakage current during ULPM and potentially damaging the unit by applying a voltage when the GPIOs are off. Similarly, there should not be any voltage applied to the GPIOs when the module is off, to prevent damaging the module.*

---

**Table 4-6: GPIO Pin Descriptions**

Pin	Signal Name	Default State	Function	If Unused
10	GPIO2 <sup>a</sup>	No pull <sup>b</sup>	General purpose I/O	Leave open
40	GPIO7			
41	GPIO8			
44	GPIO13			
46	GPIO6 <sup>c,d</sup>			
65	GPIO4 <sup>e</sup>			
92	GPIO38 <sup>f,g</sup>			
94	GPIO40 <sup>f</sup>			
95	GPIO41 <sup>f</sup>			
101	GPIO35			
102	GPIO36 <sup>f,g</sup>			
103	GPIO37 <sup>f</sup>			
104	GPIO32			
105	GPIO33			
109	GPIO42 <sup>a</sup>			
147	GPIO21 <sup>a</sup>			
148	GPIO22			
149	GPIO23			
150	GPIO24			
153	GPIO28 <sup>c</sup>			
154	GPIO29 <sup>c</sup>			
155	GPIO30 <sup>c</sup>			
156	GPIO31 <sup>c</sup>			
159	GPIO25			

- a. Pin is 'wakeable'. Can be used to trigger the module to wake up from USB-SS mode (low power active state). See [Wakeup Interrupt \(Sleep State\)](#) on page 63 for details.
- b. Internal configuration of all GPIOs—no internal pull-ups
- c. This pin is available for use when configured using AT+WIOCFG.
- d. Not available when used for RESET\_OUT\_N or external SIM multiplexer (AT!CUSTOM="EXTUIMSWITCHEN").
- e. Internal reserved function of GPIO4. Cannot change the setting via the AT command.
- f. Accessible via sysfs/Legato only.
- g. Can be configured as a wakeup trigger for ULPS. See [Power Consumption States](#) on page 25 for details.

## 4.9 Wakeup Interrupt (Sleep State)

The following pins can be used to wake the device when it is in Sleep state (low-power state):

- GPIO2
- GPIO21
- GPIO36
- GPIO38
- GPIO42
- UART1\_DTR
- UIM1\_DET

Additionally, the following sources can wake the device from Sleep state:

- wake\_lock()
- USB\_SS
- UART\_DTR
- QMI exchanges from the modem, including SMS receive

The GPIO pins can be configured as a wakeup source by using the +WIOCFG command (see [1] AirPrime WPx5/WP76xx/WP77xx AT Command Reference).

If the device firmware is monitoring these pins while the device is in Sleep state, any transition on these pins will wake the device. (Note: The UIM1\_DET pin transitions high when a UIM is installed, and low when a UIM is removed.)

---

*Note: These signals wake the device when it is in Sleep state (a low-power ACTIVE state where the module is fully powered). If the device is in ULPS, it is only woken by configured wakeup triggers — see [Table 4.10, Wakeup Events \(ULPS\)](#), on page 63 for details.*

---

## 4.10 Wakeup Events (ULPS)

The following signals/sources can be used to wake the device from ULPS:

**Table 4-7: ULPS Wakeup Signals/Sources**

Signal Configuration	Signal	Notes
Configurable	Timer	
	GPIO36, GPIO38	
	ADC2	Only one ADC at a time can be configured as a wakeup source. For example, if ADC3 is currently configured and then ADC2 is configured, the configuration for ADC3 is replaced by the ADC2 configuration.
	ADC3	
Always enabled	POWER_ON_N	

---

*Note: These signals wake the device only when it is in ULPS. If the device is in Sleep state (a low-power ACTIVE state where the module is fully powered), it can be woken using the signals described in [Wakeup Interrupt \(Sleep State\)](#) on page 63.*

---

For ULPS details, see [Table 3-5, Supported Power States](#), on page 25.

## 4.11 Secure Digital IO (SDIO) Interface

The AirPrime WP7702 module defines a 1.8 V/2.85 V SDIO interface (SD 2.0-compliant) for customer-defined use with SD cards, connection to a Wi-Fi module, etc.

*Note: An external 1.8 V/2.85 V supply is required to supply power to the SD card.*

Table 4-8 describes the signals used for SDIO.

**Table 4-8: SDIO Pin Descriptions**

Pin	Signal Name	Direction <sup>a</sup>	Description	If unused	Voltage level
161	SDIO_CMD	Output	SDIO command	Leave Open	1.8 V/2.85 V
162	SDIO_CLK	Output	SDIO clock	Leave Open	
163	SDIO_DATA_3	Input/Output	SDIO data bit 3	Leave Open	
164	SDIO_DATA_2	Input/Output	SDIO data bit 2	Leave Open	
165	SDIO_DATA_1	Input/Output	SDIO data bit 1	Leave Open	
166	SDIO_DATA_0	Input/Output	SDIO data bit 0	Leave Open	

a. Signal direction with respect to the module. Example: SDIO\_CMD (pin 161) is an output from the module to the host.

## 4.12 I<sup>2</sup>C Interface

The AirPrime WP7702 module provides one I<sup>2</sup>C (Inter-Integrated Circuit) dedicated serial port (bus interface) based on [6] I2C Bus Specification, Version 2.1, January 2000.

The interface uses the pins indicated in Table 4-9.

**Table 4-9: I<sup>2</sup>C Interface Pins**

Pin	Signal name	Direction	Function	If Unused
1	I2C1_CLK	Input/Output	I <sup>2</sup> C Clock	Leave open
66	I2C1_DATA	Input/Output	I <sup>2</sup> C Data	Leave open

This implementation of the I<sup>2</sup>C interface includes the following characteristics:

- Supported voltage — 1.8 V
- Standard-mode interface — Data transfer rates up to 100 kbit/s
- Master mode operation only — WP7702 module always operates as the master
- I<sup>2</sup>C signals are implemented internally as open drain outputs (per the I<sup>2</sup>C specification) with 2.2 k $\Omega$  pull-up resistors to VGPI0 (see Figure 4-3 on page 65).

*Note: I<sup>2</sup>C slave addresses 0x10 and 0x3a are reserved for internal use.*

For I<sup>2</sup>C bus details, including I2C bus waveform and timing details, refer to the I2C Bus Specification.

### 4.12.1 Application

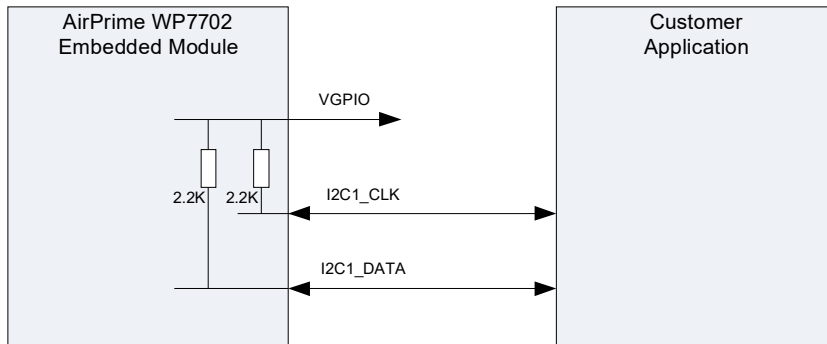

Figure 4-3: Example of I<sup>2</sup>C Bus Application

## 4.13 VGPIO

The AirPrime WP7702 utilizes 1.8V logic, provided via the VGPIO (GPIO voltage output) pin.

Table 4-10: VGPIO Reference Pin

Pin	Signal name	Direction <sup>a</sup>	Function	If Unused
45	VGPIO	Output	GPIO voltage output	Leave open

a. Signal direction with respect to the module—VGPIO (pin 45) is an output from the module to the host.

Table 4-11: VGPIO Electrical Characteristics

Parameter	Min	Typ	Max	Unit	Remarks
Voltage level	1.7	1.8	1.9	V	Both active mode and USB-SS mode
Current capability	-	-	50	mA	Power Management support up to 50 mA output

The VGPIO pin is available when the module is in Active power state, and can be used to:

- Pull up GPIOs (GPIOs 2,7, 8, 13, 21–25, 32, 33, 35, 42)
- Supply external digital transistors driving LEDs
- Act as a voltage reference for ADC interfaces (ADC0, ADC1)

*Note: VGPIO is floating (not available) when the module is OFF or in ULPS.*

## 4.14 Reset Signal (RESET\_IN\_N)

The AirPrime WP7702 provides an interface to allow an external application to reset the module.

**Table 4-12: RESET\_IN\_N Pin**

Pin	Signal name	Direction <sup>a</sup>	Function	If Unused
11	RESET_IN_N	Input	External Reset Input	Leave open

a. Signal direction with respect to the module—RESET\_IN\_N (pin 11) is an input to the module from the host.

The RESET\_IN\_N signal is internally pulled-up with an internal resistor. An open collector transistor or equivalent should be used to ground the signal when necessary to reset the module.

To reset the module, a low level pulse must be sent on the RESET\_IN\_N pin for 8 s. This will immediately restart the module with the POWER\_ON\_N signal at low level. (If the POWER\_ON\_N signal is at high level, the module will be powered off.)

The RESET\_IN\_N signal will reset the registers of the CPU and reset the RAM memory as well, for the next power on.

*Note: Using RESET\_IN\_N to reset the module could result in memory corruption if used inappropriately. This signal should only be used if the module has become unresponsive and it is not possible to perform a power cycle.*

**Table 4-13: Reset Timing**

Symbol	Parameter	Min	Typ	Max
Trdet	Duration of RESET_IN_N signal before firmware detects it (debounce timer)	-	8 s	-
Trlen	Duration reset asserted	42 ms	-	∞
Trdel	Delay between minimum Reset duration and internal reset generated	-	500 ms	-

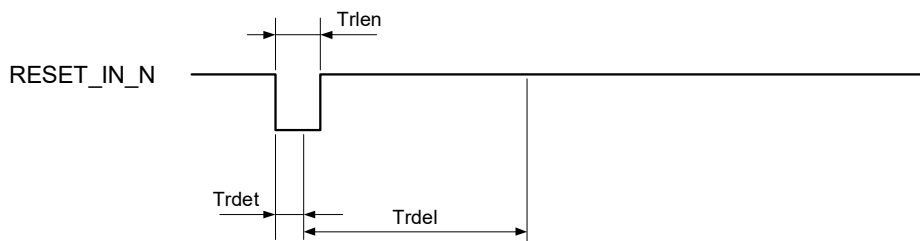

Figure 4-4: Illustration of Reset Timing When RESET\_IN\_N < Trdel

## 4.15 Reset Out (RESET\_OUT\_N)

The AirPrime WP7702 provides the RESET\_OUT\_N signal, which will hold peripheral devices (such as a USB hub, I2C device, etc.) in reset until the power-up sequence is complete.

**Table 4-14: RESET\_OUT\_N Pin**

Pin	Signal name	Direction <sup>a</sup>	Function	If Unused
46	RESET_OUT_N	Output	Module reset peripheral device control	Leave open

a. Signal direction with respect to the module — RESET\_OUT\_N is an output from the module to the host.

When the module is in reset or powering up, the signal is held low to put peripheral devices in reset. Once the power-on sequence is complete, the RESET\_OUT\_N signal will be turned high to take the peripherals out of reset.

*Note: The primary use of pin 46 is as GPIO6. To enable RESET\_OUT\_N functionality on pin 46, use AT+WIOCFG=6,0.*

## 4.16 ADC

The AirPrime WP7702 provides four general purpose ADC (Analog to Digital Converter) inputs, as described [Table 4-15](#) and [Table 4-16](#).

**Table 4-15: ADC Interface Pins**

Pin	Signal name	Direction <sup>a</sup>	Function	If Unused
24	ADC1	Input	Analog to Digital Converter	Leave open or Ground
25	ADC0	Input	Analog to Digital Converter	Leave open or Ground
107	ADC2 <sup>b</sup>	Input	Analog to Digital Converter	Leave open or Ground
108	ADC3 <sup>b</sup>	Input	Analog to Digital Converter	Leave open or Ground

a. Signal direction with respect to the module. Example: ADC1 (pin 24) is an input to the module from the host.

b. Pin is 'wakeable'. Can be used to trigger the module to wake up from USB-SS mode (low power active state). See [Wakeup Events \(ULPS\)](#) on page 63 for details.

**Table 4-16: ADC Interface Characteristics**

	ADC0 / ADC1 Value	ADC2 / ADC3 Value	Units
Full-scale voltage level	0.1–1.7	0–1.8	V
Resolution	15	12	bit
Sample rate	1.15	20.000–818.330	ksps
Voltage error	8 (Typ) 16 (Max)	2 (Typ)	mV

## 4.17 SPI Bus

The AirPrime WP7702 module provides one 4-wire serial peripheral interfaces (SPI1).

The following features are available on the SPI bus:

- Mode: Master (Slave mode is not supported)
- SPI speed from 960 kbps to 25 Mbps in master mode operation
- 4-wire interface
- 4 to 32 bits data length

Table 4-17 on page 68 describes the SPI interface pins.

**Table 4-17: SPI Pin Descriptions**

Pin	Signal Name	Direction <sup>a</sup>	Description	Reset State	I/O Type
51	SPI1_MRDY	Output	SPI Master Ready	Z	1V8
52	SPI1_MISO	Input	SPI Master Input/Slave Output (output from slave)	Z	
53	SPI1_CLK	Output	SPI serial clock (output from Master)	Z	
54	SPI1_MOSI	Output	SPI Master Output/Slave Input (output from master)	Z	

- a. Signal direction with respect to module. Examples: SPI1\_MISO (pin 52) is an input too the module from the host; SPI1\_CLK (pin 53) is an output from the module to the host.

### 4.17.1 SPI Configuration

Table 4-18: SPI Configuration

Operation	Max Speed	SPI-Mode	Duplex	4-wire Type
Master	25 Mb/s	0,1,2,3	Full	<ul style="list-style-type: none"> <li>▪ SCLK (SPI1_CLK)</li> <li>▪ MOSI (SPI1_MOSI)</li> <li>▪ MISO (SPI1_MISO)</li> <li>▪ SS (SPI1_MRDY)</li> </ul>

### 4.17.2 SPI Waveforms

The following figure shows waveforms for SPI transfer using a 4-wire configuration.

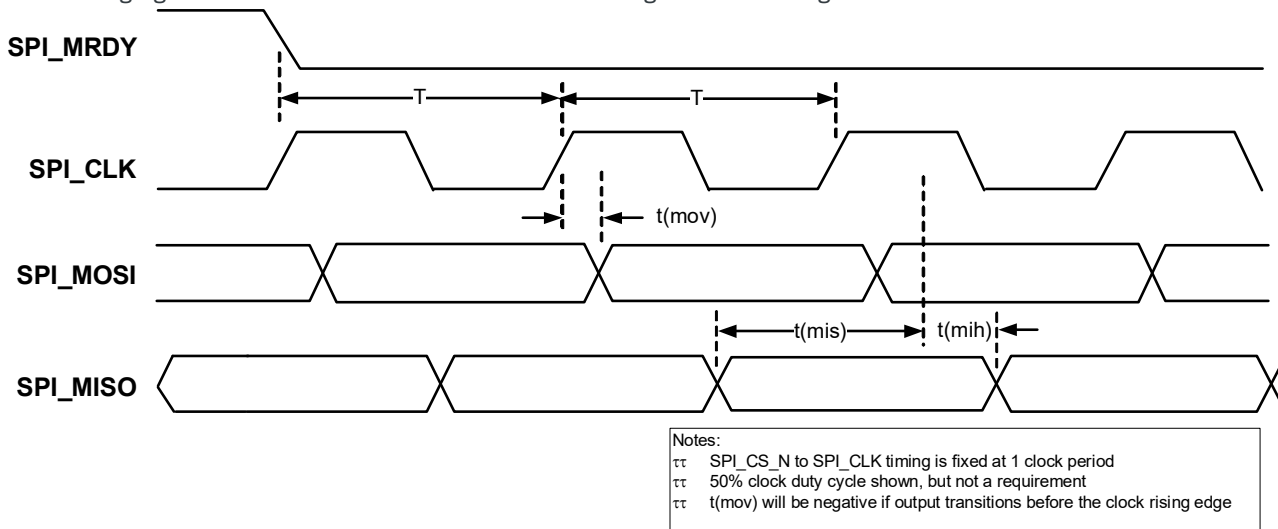

Figure 4-5: 4-Wire Configuration SPI Transfer

Table 4-19: SPI Master Timing Characteristics (@50 MHz)

Parameter		Min	Typ	Max	Unit
SPI clock frequency		-	-	38	MHz
T <sup>a</sup>	SPI clock period	20.0	-	-	ns
t(ch)	Clock high	9.0	-	-	ns
t(cl)	Clock low	9.0	-	-	ns
t(mov)	Master output valid	-5.0	-	-5.0	ns
t(mis)	Master input setup	5.0	-	-	ns
t(mih)	Master input hold	1.0	-	-	ns

a. Minimum clock period includes 1% jitter of the maximum frequency

### 4.17.3 Application

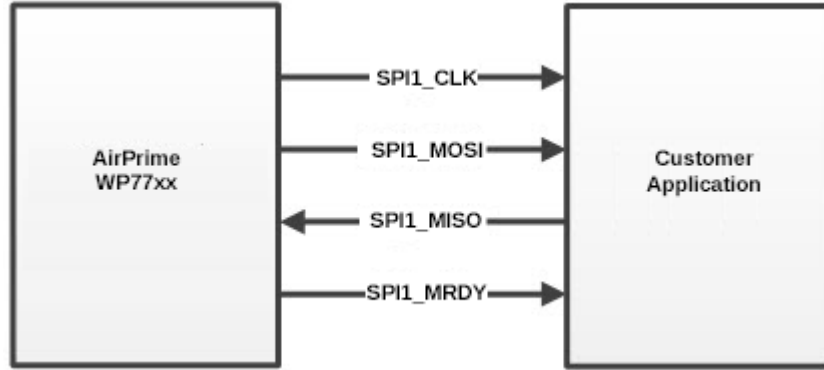

Figure 4-6: Example of 4-wire SPI Bus Application

## 4.18 HSIC Bus

AirPrime WP7702 module provides a 2-wire HSIC (High-Speed Inter-Chip) bus.

**Important:** *If the HSIC bus is not used on the host application, a pull-down resistor (20k–50k) should be added to each HSIC line to disable the interface. (Alternatively, the interface can be disabled using the !CUSTOM AT command with the "HSICENABLE" customization. See [1] AirPrime WPx5 / WP76xx / WP77xx AT Command Reference for details.)*

Table 4-20: HSIC Pin Descriptions

Pin	Signal Name <sup>a</sup>	Direction <sup>a</sup>	Description	Reset State	I/O Type
14	HSIC_DATA	I/O	HSIC data	Z	1V2
15	HSIC_STRB	I/O	HSIC strobe signal	Z	

a. From host view

### 4.18.1 HSIC Waveforms

Refer to [2] Inter-Chip USB Supplement to the USB 2.0 Specification Revision 1.0.

## 4.18.2 Application

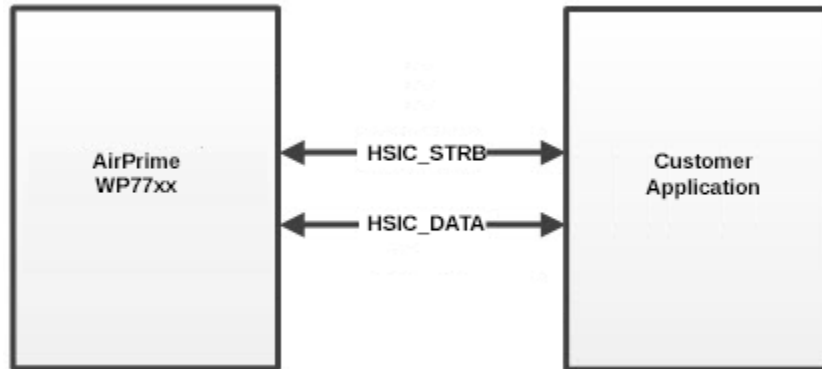

Figure 4-7: Example of 2-wire HSIC Bus Application

Application notes:

- Trace length < 10 cm
- Skew between data and strobe signals < 15 ps
- HSIC\_DATA and HSIC\_STRB should maintain a 50 $\Omega$  impedance routing, and isolation between the lines should be maintained

## 4.19 Clock

The AirPrime WP7702 module supports two digital clock interfaces that are connected directly from the PMIC.

Table 4-21 describes the clock interface pins.

Table 4-21: Clock Interface Pin Descriptions

Pin	Signal name	I/O	I/O type	Description	If Unused
22	SYS_CLK	Output	1.8V	19.2 MHz digital clock output	Leave open
23	SLEEP_CLK	Output	1.8V	32.768 kHz digital clock output	Leave open

## 4.20 TP1 (Boot Pin)

The TP1 pin (boot pin) can be used for two primary purposes:

- The pin can be used to force the module to enter boot-loader mode on power-up — Connect the pin to a control mechanism (for example, a button, switch, or jumper) on the host platform, and use this mechanism to assert (drive low) the TP1 pin on power-up. The boot loader monitors the TP1 pin and when it detects a low signal, prevents normal power-up and prepares to download firmware via the DM port.  
When the module has restarted and entered boot-loader mode, make sure to de-assert the TP1 pin. When the firmware download finishes, the module reboots automatically and the de-asserted pin allows the module to boot normally.
- If not connected to a control mechanism, at minimum the pin should be connected to a test point on the host platform, for use by Semtech in RMA debugging.

Note: Firmware downloads also occur using software tools available on [source.sierrawireless.com](http://source.sierrawireless.com) or over the air using an AirVantage server.

Table 4-22: TP1 Pin Description

Pin	Name	Direction	Function	If Unused
47	TP1	Input	Device recovery (boot load)	Mandatory test point

## 4.21 Temperature Monitoring

The AirPrime WP7702 provides internal temperature monitoring of the module’s baseband thermistor, as detailed below in Figure 4-8 and Table 4-23.

The temperature state can be queried directly, and unsolicited notifications of temperature state transitions can be received by using:

- AT!PATEMP—Display the current temperature state (normal, hi or low warning, hi or low critical).
- AT+WUSLMSK—Enable unsolicited notifications for !PATEMP, to be received over the AT port whenever the state changes.

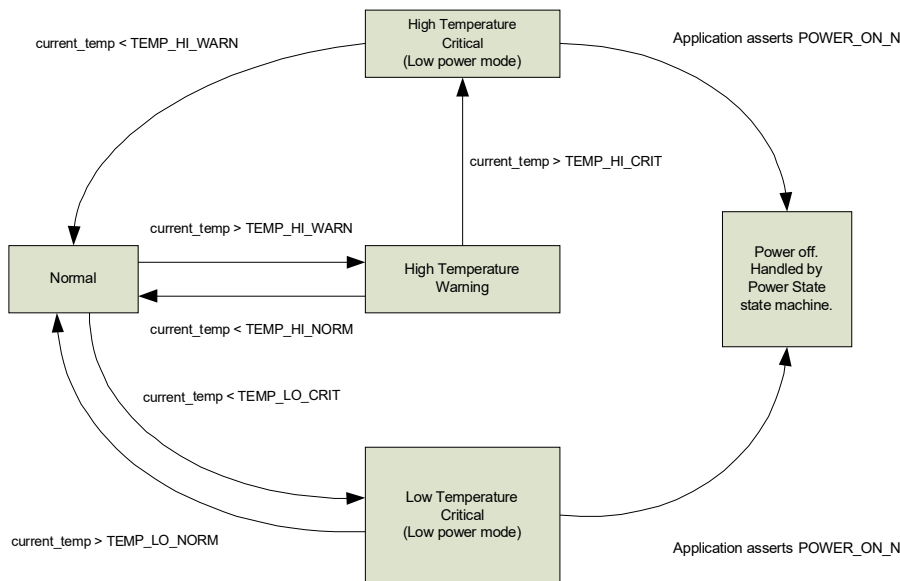

Figure 4-8: Temperature Monitoring State Machine

Table 4-23: Temperature Monitoring States

State	Description	Threshold	Default Temp value (C) <sup>a</sup>	Functionality
Normal	Baseband thermistor is between	TEMP_HI_NORM	+100	All
		TEMP_LO_NORM	-40	

Table 4-23: Temperature Monitoring States (Continued)

State	Description	Threshold	Default Temp value (C) <sup>a</sup>	Functionality
High Temperature Warning	Baseband thermistor has exceeded	TEMP_HI_WARN	+110	All
High Temperature Critical	Baseband thermistor has exceeded	TEMP_HI_CRIT	+115	Low Power Mode
Low Temperature Critical	Baseband thermistor has descended past	TEMP_LO_CRIT	-45	Low Power Mode

a. Junction (PA thermistor) temperature

To restore full operation, the baseband thermistor's temperature reading must be within the normal or high temperature warning state thresholds.

## 4.22 Test Pins

Semtech requires test points on the customer application for Semtech RMA and debug service.

Table 4-24: Test Pin Descriptions

Pin	Name	Function	If Unused
236	J1	Test point	Mandatory test point
237	J2	Test point	Mandatory test point
238	J3	Test point	Mandatory test point
239	J4	Test point	Mandatory test point
240	J5	Test point	Mandatory test point
241	J6	Test point	Mandatory test point
242	J7	Test point	Mandatory test point
243	J8	Test point	Mandatory test point
244	J9	Test point	Mandatory test point

## 4.23 Antenna Control

*Note: Antenna control signals support is optional.*

The AirPrime WP7702 provides four output signals that can be used for host designs that incorporate tunable antennas.

*Note: Host design developers are responsible for evaluating the performance of tunable antennas that use ANT\_CNTRLx signals for neighbor cell measurements, Inter-RAT handovers, etc. Semtech does not guarantee ANT\_CNTRLx signal timing.*

Note: These pins can be configured for use as GPIOs using +WIOCFG.

**Table 4-25: Antenna Control Signals**

Pin	Name	Direction <sup>a</sup>	Function	If Unused
153	ANT_CNTLO	Output	Customer-defined external switch control for tunable antennas	Leave open
154	ANT_CNTL1	Output		Leave open
155	ANT_CNTL2	Output		Leave open
156	ANT_CNTL3	Output		Leave open

a. Signal direction with respect to module. Examples: ANT\_CNTLO (pin 153) is an output from the module to the host.

To tune the antenna:

1. Enable band selection, which is required to tune the antennas for specific bands:
  - **AT!CUSTOM="BANDSELEN",1**  
(Note: This setting is persistent unless disabled by issuing AT!CUSTOM="BANDSELEN",0.)
2. Drive the antenna control signals high or low, as required, for a specific band:
  - **AT!ANTSEL=<band>, <gpio1>, <gpio2>, <gpio3>[, <gpio4>]**  
(<gpio1>--<gpio4> correspond to ANT\_CTRL0–ANTCTRL3.)  
See [1] AirPrime WPx5/WP76xx/WP77xx AT Command Reference for details.

Note: Perform system-level testing to ensure that the antenna switching features does not introduce any handover issues. The tunable antenna should be designed to ensure that it can return in < 5 μs (recommended) and < 10 μs (maximum).

## 4.24 Indication Interfaces

The AirPrime WP7702 module provides several indication interfaces that deliver notifications when specific events occur. These interfaces include:

- [Tx Activity Indicator \(TX\\_ON\)](#) on page 75
- [WWAN\\_LED\\_N](#) on page 75
- [WAKE\\_ON\\_WWAN](#) on page 76
- [Ring Indicator](#) on page 76
- [SAFE\\_PWR\\_REMOVE](#) on page 76
- [UIM1\\_DET](#) on page 77

Note: For digital electrical characteristics of these signals (except WWAN\_LED\_N and SAFE\_PWR\_REMOVE, see [Table 3-24](#) on page 47).

### 4.24.1 Tx Activity Indicator (TX\_ON)

The AirPrime WP7702 module provides a digital output signal to indicate the occurrence of Tx activity.

Table 4-26: Tx Activity Indicator States

Pin	Signal name	Direction <sup>a</sup>	I/O type	Module state	Signal State
60	TX_ON	Output	1.8V	During Tx activity	High
				No Tx	Low

a. Signal direction with respect to module — TX\_ON (pin 60) is an output from the module to the host.

### 4.24.2 WWAN\_LED\_N

The AirPrime WP7702 provides an LED control output signal pad. This signal is an open drain output.

Table 4-27: LED Interface Pin

Pin	Signal name	Direction <sup>a</sup>	Voltage / Current	Function	If Unused
106	WWAN_LED_N	Output	<ul style="list-style-type: none"> <li>▪ Voltage (max)=VBAT_BB + 0.5 V</li> <li>▪ Maximum current sink capability=40 mA</li> </ul>	LED driver control	Leave open

a. Signal direction with respect to module — WWAN\_LED\_N (pin 106) is an output from the module to the host.

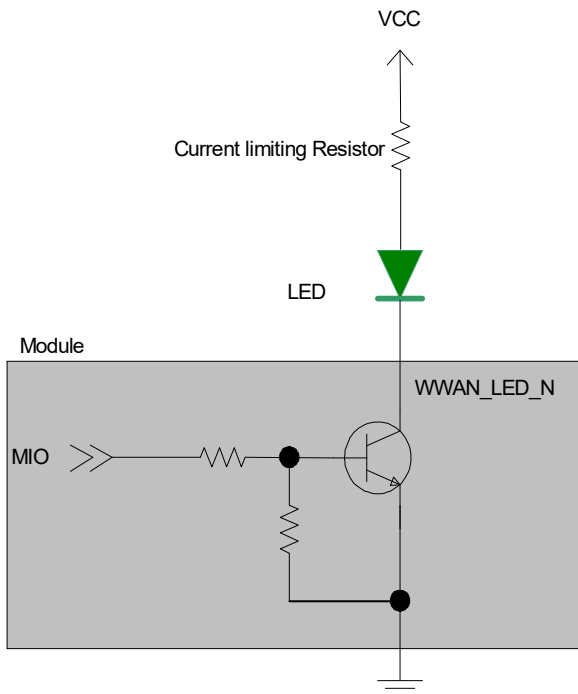

Figure 4-9: LED Reference Circuit

### 4.24.3 WAKE\_ON\_WWAN

*Note: Host support for WAKE\_ON\_WWAN signal is optional.*

The AirPrime WP7702 drives WAKE\_ON\_WWAN high to wake the host when specific events occur. See [Figure 4-10](#) on page 76 for a recommended implementation.

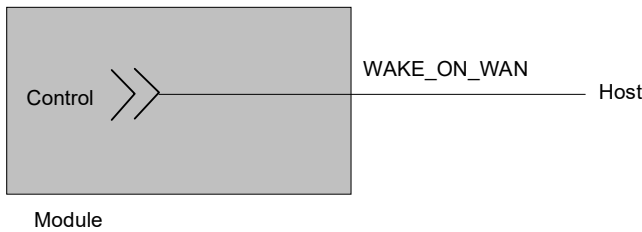

Figure 4-10: Recommended WAKE\_ON\_WWAN Connection

### 4.24.4 Ring Indicator

The ring indicator (UART1\_RI) may be used to notify an external application of several events such as an incoming call, timer expiration, or incoming SMS. The AirPrime WP7702 pulses the signal high when an event occurs.

Table 4-28: UART1\_RI Pin

Pin	Name	Direction <sup>a</sup>	Function	If unused
2	UART1_RI <sup>b</sup>	Output	Ring Indicator Signal incoming data, SMS, etc.	Leave open

- a. Signal direction with respect to the module — UART1\_RI (pin 2) is an output from the module to the host.
- b. Do not install an external pull-up on this pin, otherwise the module will not boot.

For additional details, refer to the Legato API documentation at [legato.io](http://legato.io).

### 4.24.5 SAFE\_PWR\_REMOVE

The SAFE\_PWR\_REMOVE signal is used by the AirPrime WP7702 to indicate to the host device that VBAT\_BB / VBAT\_RF can be removed. The signal is driven high when it is safe to remove the power supply.

Table 4-29: SAFE\_PWR\_REMOVE Pin details

Pin	Parameter	Comments	Min	Max	Units
152	V <sub>OH</sub>	Module OFF above this value	1.5	-	V
	V <sub>OL</sub>	Module ON below this value	-	0.3	V

## 4.24.6 UIM1\_DET

The UIM Detect signal (UIM1\_DET) is used to detect the physical presence of a UIM card in the UIM holder. The UIM Detect signal has a pull-up internal to the AirPrime WP7702. It should be set to GND when a UIM is not present. All signals near the UIM holder must be ESD-protected.

The UIM Detect signal transitions:

- When a UIM is inserted — high (logic 0 to logic 1)
- When a UIM is removed — low (logic 1 to logic 0)

## 4.25 DR\_SYNC

The AirPrime WP7702 provides DR\_SYNC, an output used for GPS dead reckoning synchronization.

The module pulses the DR\_SYNC signal once every integer GPS second. While position fixes are occurring, the DR\_SYNC pulse is aligned precisely with the GPS time. When a position fix cannot be made (for example, when a vehicle has entered a tunnel), the module continues to pulse the DR\_SYNC signal every second while the level of uncertainty of the GPS time is low. When the uncertainty level is high, the module stops pulsing the signal.

**Table 4-30: DR\_SYNC Pin Details**

Pin	Signal name	Direction <sup>a</sup>	Function	If Unused
42	DR_SYNC	Output	GPS dead reckoning sync signal	Leave open

a. Signal direction with respect to the module — DR\_SYNC (pin 42) is an output from the module to the host.

## 4.26 W\_DISABLE\_N — Wireless Disable

*Note: Host support for wireless disable signals is optional.*

The host device uses W\_DISABLE\_N (pin 151) to enable / disable the WWAN or radio modem. When disabled, the modem cannot transmit or receive information.

Letting this signal float high allows the module to operate normally. The pin has an internal pull-up resistor. See [Figure 4-11](#) for a recommended implementation.

When integrating with your host device, keep the following in mind:

- The signal is an input to the module and should be driven LOW only for its active state (controlling the power state); otherwise it should be floating or (High impedance). It should never be driven to a logic high level. The module has an internal pull-up resistor to an internal 1.8V rail, so if the signal is floating or (high impedance), then the radio is on.
- If the host never needs to assert this power state control to the module, leave this signal unconnected from the host interface.

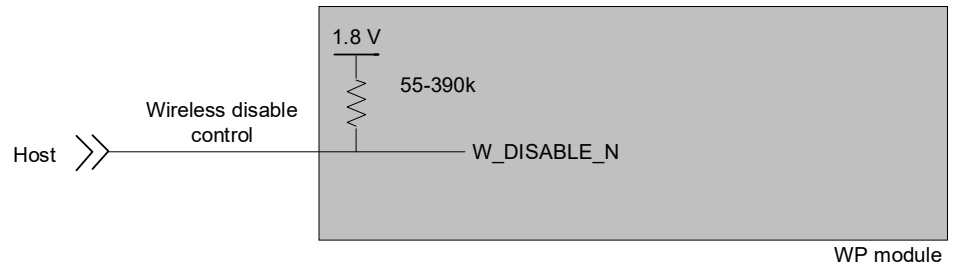

Figure 4-11: Recommended Wireless Disable Connection

# 5: Routing Constraints and Recommendations

This section describes general routing constraints and recommendations for the AirPrime WP7702 module.

---

*Note: This is a non-exhaustive list of suggested design guidelines. The developer is responsible for deciding whether to implement these guidelines.*

---

## 5.1 General Rules and Recommendations

Clock and other high-frequency digital signals (e.g. serial buses) should be routed as far as possible from the module's analog signals.

If the application design makes it possible, all analog signals should be separated from digital signals by a ground trace on the PCB.

---

**Tip:** Avoid routing any signals under the module on the application board.

---

## 5.2 PCB Layout Recommendations

Ground pads should be re-flowed on to the host PCB with < 30% voiding to allow effective heat dissipation.

## 5.3 Power Supply

When designing the power supply, make sure that VBAT\_BB/VBAT\_RF meet the requirements listed in [Power Supply Ratings](#) on page 22.

Careful attention should be paid to the following:

- Power supply quality — PFM, or PSM systems should be avoided; Low ripple, linear regulation or PWM converters are preferred for low noise.
- Capacity to deliver high current peaks in a short time (for pulsed radio emission)
- VBAT\_BB/VBAT\_RF must support peak currents with an acceptable voltage drop that guarantees the minimum required VBAT\_BB/VBAT\_RF value.
- VBAT\_BB/VBAT\_RF signal pads must never exceed the maximum required VBAT\_BB/VBAT\_RF value, otherwise the module's power amplifier and GPS chipset may be severely damaged.
- A weakly-designed (not robust) power supply could affect EMC performance, the emission spectrum, and the phase error and frequency error.

## 5.4 Antenna

Semtech strongly recommends working with an antenna manufacturer either to develop an antenna adapted to the application, or to adapt an existing solution to the application.

For information on routing constraints for the RF circuit, see [RF Circuit](#) on page 81.

## 5.5 PCB Specifications for the Application Board

Sensitive signals (such as UIM and clocks) should be protected by ground planes /fills. Routing sensitive signals close to noisy signals could result in noise being coupled.

## 5.6 Recommended PCB Land Pattern

Refer to the AirPrime WP76XX Customer Process Guidelines document, available at <http://source.sierrawireless.com>.

## 5.7 Routing Constraints

### 5.7.1 Power Supply

If the following design recommendations are not followed, phase error (peak) and power loss could occur.

- Since maximum peak current can reach 2.5 A, Semtech strongly recommends having a large width for the layout of the power supply signal (to avoid voltage loss between the external power supply and VBAT\_BB/VBAT\_RF).

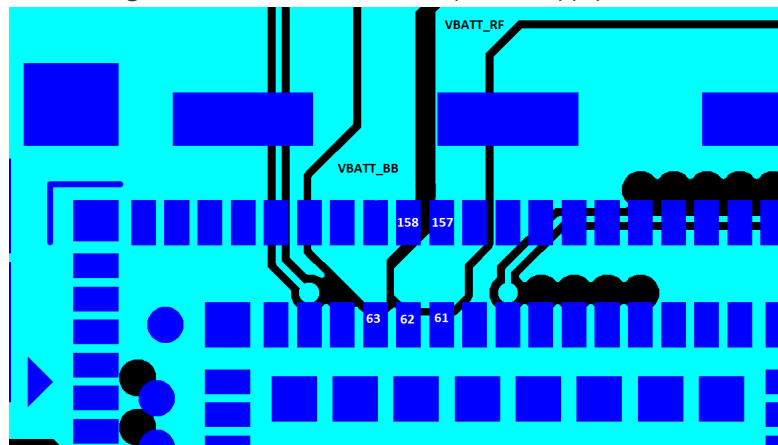

Figure 5-1: Power Supply Routing Example

*Note:*

- Figure 5-1 shows separate traces for VBAT\_BB and VBAT\_RF. If VBAT\_BB and VBAT\_RF share a single power supply, these traces should be connected.
- For optimal decoupling, place the capacitors on the underside of the board, directly under the pins.
- The recommended power supply capacity (Table 3-3 on page 23) is greater than the maximum peak current to provide an operating margin.
- Input capacitors (2×47 μF) are required close to the module.
- Attention should be paid to the ground trace or the ground plane on the application board for the power supply that supplies the module. The ground trace or ground plane, as well as the VBAT trace, must be able to support current peaks.
- If the ground trace between the module and the power supply is a copper plane, make sure it is a solid plane.
- Design routing to make sure total line impedance does not exceed 10 mΩ @ 217 Hz.

### 5.7.1.1 Ground Plane Connection

The AirPrime WP7702 module requires a solid, central ground plane (with solder mask defined pads) located directly under the module. This will:

- Ensure high current signal returns
- Provide heat dissipation under higher operating temperatures

The ground plane should be connected (with vias) to the reference ground layer of the application board.

### 5.7.2 UIM Interface

- Tracks between the AirPrime WP7702 and the UIM socket should be as short as possible. Maximum recommended length is 10cm.
- ESD protection is mandatory on the UIM lines unless:
  - An ESIM is being used, or
  - There is no physical access to the UIM
- The decoupling capacitor(s) should be placed as close as possible to the UIM card connector for the UIM1\_VCC signal.

### 5.7.3 RF Circuit

The RF signal must be routed on the application board using tracks with a 50 $\Omega$  characteristic impedance.

The characteristic impedance depends on the dielectric, the track width and the ground plane spacing.

It is recommended to use stripline design if the RF path is fairly long (more than 3cm), since microstrip design is not shielded. Consequently, the RF (transmit) signal may interfere with neighboring electronic circuits. In the same way, the neighboring electronics (micro-controllers, etc.) may interfere with the RF (receive) signal and degrade the reception performance.

The RF trace on the development board is routed from the AirPrime WP7702 antenna port to the RF connector (IPEX MHF-4). The RF trace is designed as a 50 $\Omega$  coplanar stripline and its length is 20.7 mm.

The following drawings show the location of the AirPrime WP7702 on the development board, the routing cross-section, and the top view of the RF trace on the development board.

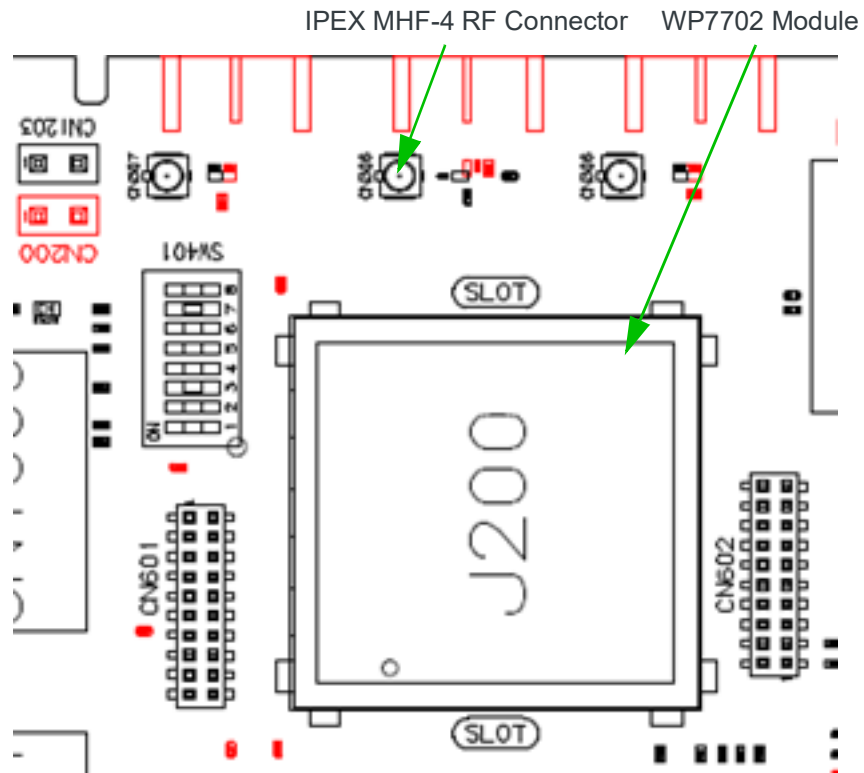

Figure 5-2: Module Location on Development Board

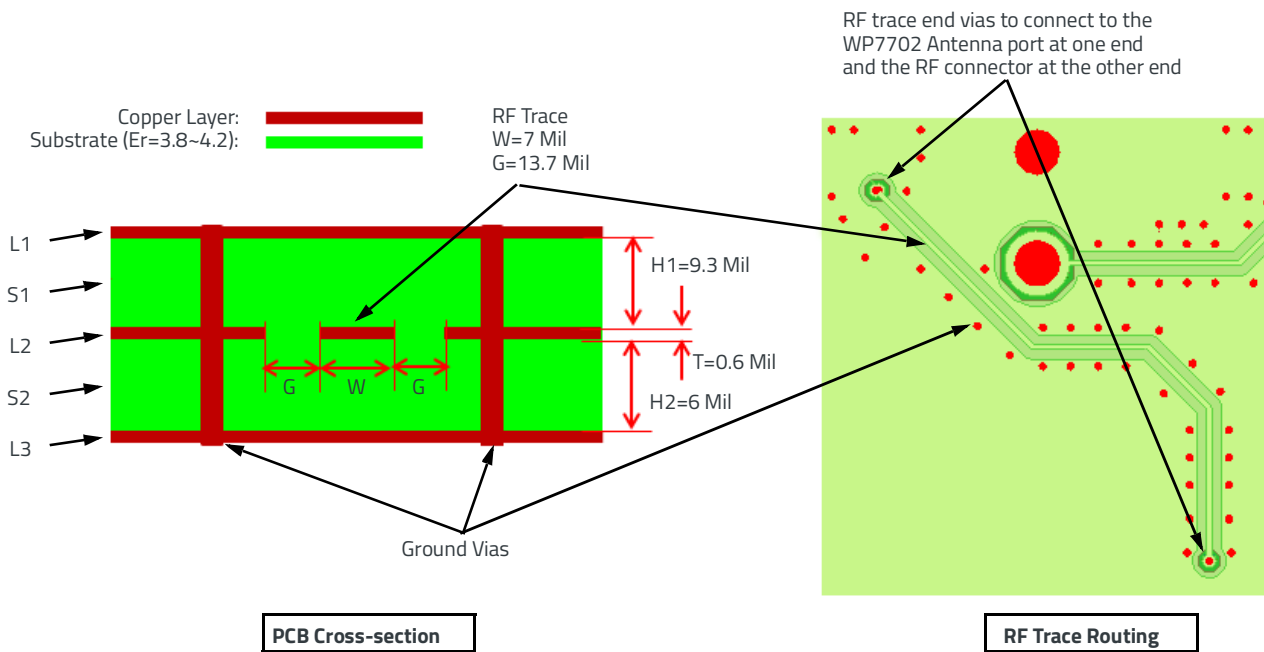

Figure 5-3: Development Board RF Trace Design

## 5.7.4 USB Interface

When the USB interface is externally accessible, ESD protection is required on the USB\_VBUS, USB\_D+, and USB\_D- signals.

## 5.8 Thermal Considerations

To enhance thermal dissipation:

- Maximize airflow over / around the module
- Locate the module away from other components that generate heat
- Ensure the module is connected to a solid ground plane

The amount of thermal dissipation required is application-dependent; factors to consider include the supply voltage, location of the module within the host, amount and frequency of data transferred, etc.

## 5.9 EMC and ESD Recommendations

EMC tests must be performed on the application as soon as possible to detect any potential problems.

When designing, special attention should be paid to:

- Possible spurious emissions radiated by the application to the RF receiver in the receiver band
- ESD protection — Typically, ESD protection is mandatory for externally accessible signals, including:
  - VBAT\_RF/VBAT\_BB
  - UIM (if accessible from outside)
  - Serial link
  - USB
  - Antennas
- Length of the UIM interface lines (preferably < 10 cm)
- Length of the HSIC interface lines (< 10 cm, as required by the HSIC specification)
- Ground plane: Semtech recommends a common ground plane for analog/digital/RF grounds

---

*Note: The AirPrime WP7702 does not include any protection against over-voltage.*

---

The host device must provide adequate ESD protection on digital circuits and antenna ports as detailed in the following table.

*Note: The level of protection required depends on your application.*

**Table 5-1: ESD Specifications <sup>a</sup>**

Category	Connection	Specification
Operational	<ul style="list-style-type: none"> <li>▪ RF ports</li> <li>▪ UIM connector</li> <li>▪ USB connector</li> <li>▪ UART connector</li> </ul>	IEC-61000-4-2 - Level (Electrostatic Discharge Immunity Test) <ul style="list-style-type: none"> <li>· ± 6kV Contact</li> <li>· ± 8kV Air</li> </ul>
Non-operational	Host connector interface	Unless otherwise specified: <ul style="list-style-type: none"> <li>▪ JESD22-A114 ± 1kV Human Body Model</li> <li>▪ JESD22-A115 ± 100V Machine Model</li> <li>▪ JESD22-C101C ± 500V Charged Device Model</li> </ul>

a. ESD protection is highly recommended at the point where the UIM contacts are exposed, and for any other signals that would be subjected to ESD by the user.

## 5.10 Mechanical Integration

Attention should be paid to:

- Antenna cable integration (bending, length, position, etc)
- Pads of the AirPrime WP7702 to be soldered to the ground plane
- Ensuring proper board layout
- Providing sufficient space around the module for heat dissipation

## 5.11 Signal Reference Schematics

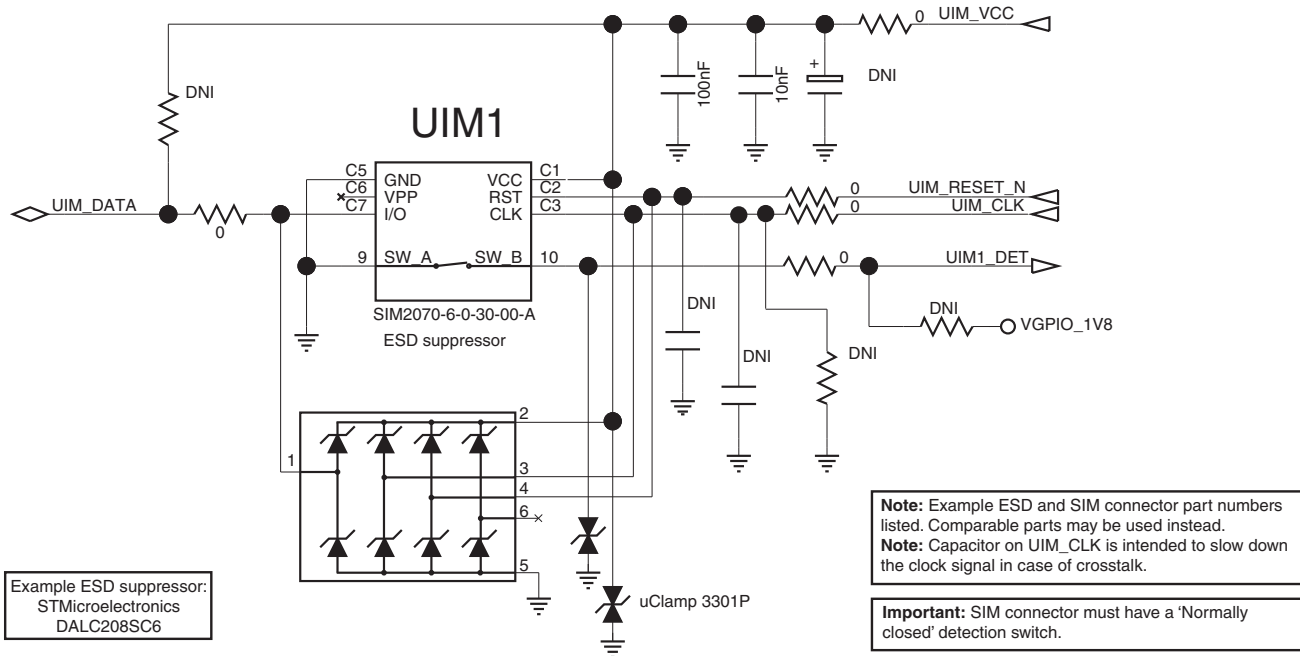

Figure 5-4: UIM Interface

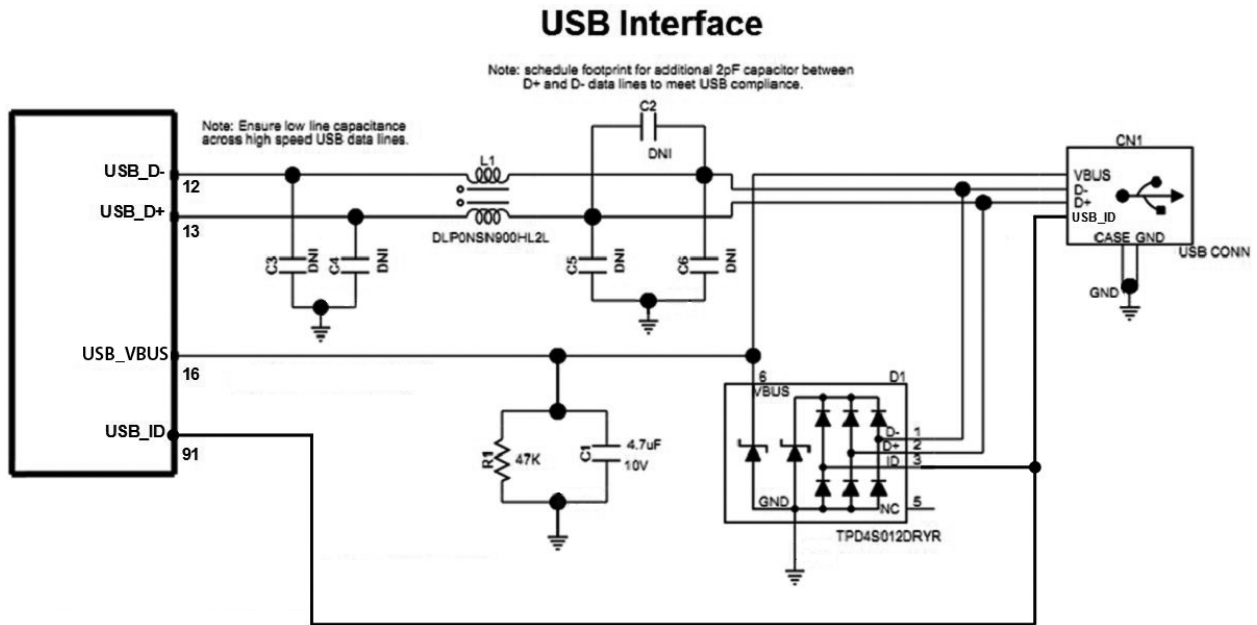

Figure 5-5: USB Interface

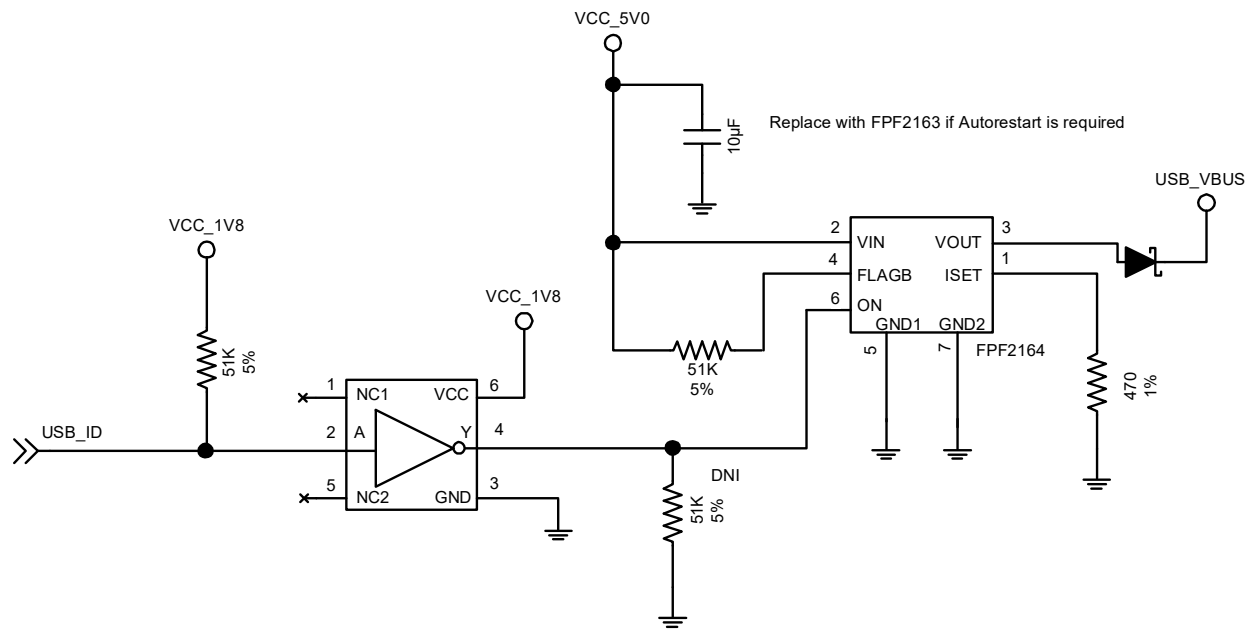

Figure 5-6: USB OTG Interface

# 6: Software and Tools

## 6.1 Support Tools

The AirPrime WP7702 is compatible with Semtech's SwiLogPlus trace tool that allows users to send error logs to Semtech.

## 6.2 SED (Smart Error Detection)

The AirPrime WP7702 uses a form of SED to track premature module resets. In such cases, the module automatically forces a pause in boot-and-hold mode at power-on to accept an expected firmware download to resolve the problem.

1. Module tracks consecutive resets within 30 seconds of power-on.
2. After a sixth consecutive reset, the module waits in boot-and-hold mode (up to 30 seconds) for a firmware download to resolve the power-cycle problem.

A RAM dump tool that can be used to help isolate the cause of premature resets is available from Semtech. Contact your Semtech account representative for assistance.

## 6.3 Firmware Upgrade

The AirPrime WP7702 module's firmware is stored in flash memory. Upgrades (entire firmware or select components) can be downloaded to the embedded module directly over the USB interface, or over-the-air (FOTA — Firmware Over the Air) via Semtech's AirVantage.

Contact your Semtech account representative for assistance.

---

**Important:** *Modules running Release 13 (or higher) firmware must not be downgraded to Release 12 or older, otherwise data that was saved in secure storage may become permanently inaccessible.*

---

### 6.3.1 FOTA Recommendation

For best performance, Semtech strongly recommends performing FOTA upgrades over LTE-M, if available.

FOTA over LTE-NB1 is also supported, but not recommended. If LTE-NB1 must be used, the following effects due to the very low data rates for LTE-NB1 should be considered:

- Possible interruption of firmware downloads due to very low LTE-NB1 data rates
- Battery drain due to long download duration
- Possible overage fees for devices with data-limiting cellular plans

# 7: Debug and Assembly Considerations

## 7.1 Testing Assistance Provided by Semtech

Semtech offers optional professional services based assistance to OEMs with regulatory approvals.

## 7.2 Integration Requirements

When integrating the AirPrime WP7702 module, the following items must be addressed:

- Mounting — Effect on temperature, shock, and vibration performance
- Power supply — Impact on battery drain and possible RF interference
- Antenna location and type — Impact on RF performance
- Regulatory approvals — As discussed in [Approval](#) on page 95
- Service provisioning — Manufacturing process

Semtech provides guidelines for successful AirPrime WP7702 module integration with the document suite and offers integration support services as necessary.

## 7.3 IOT/Operator

Interoperability and Operator/Carrier testing of the finished system is the responsibility of the OEM. The test process will be determined with the chosen network operator(s) and will be dependent upon your business relationship with them, as well as the product's application and sales channel strategy.

Semtech offers assistance to OEMs with the testing process, if required.

## 7.4 Module Testing Recommendations

When testing your integration design:

- Test to your worst case operating environment conditions (temperature and voltage)
- Test using worst case operation (transmitter on 100% duty cycle, maximum power)
- Monitor the module's junction temperature using AT!PATEMP. This command polls a thermistor located near the module's power amplifier (typically the hottest spot on the module).

---

*Note: Make sure that your system design provides sufficient cooling for the integrated module. The RF shield temperature should not be exposed to an ambient temperature greater than 85 °C to prevent damage to the module's components.*

---

## 7.5 Serial Link Access

Direct access to the UART1/UART2 serial link is very useful for:

- Testability operations
- Firmware download (for more information on firmware upgrade, see [SED \(Smart Error Detection\)](#) on page 87)
- Accessing the module's Linux console for debugging

*Note: This interface is dedicated to Linux traces.*

Refer to the following figure for a level shifter implementation that allows UART1 serial link access. (A UART2 level shifter would use the corresponding WP7702 UART2 pins — UART2\_TX (pin 96), UART2\_RX (pin 97), UART2\_RTS (pin 98), UART2\_CTS (pin 99).)

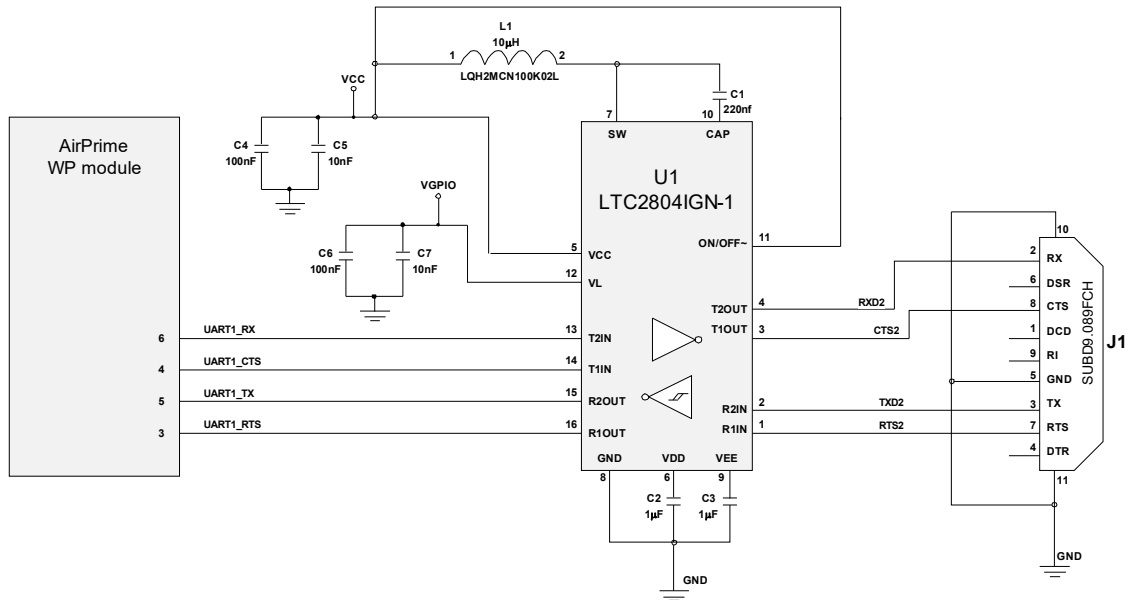

Figure 7-1: Level Shifter Implementation for UART1 Serial Link Access

## 7.6 RF Output Accessibility

During the integration phase of the AirPrime WP7702, it can be helpful to connect the module to a simulator to check critical RF TX parameters and power behavior for supported RATs (LTE, GPRS/EDGE (WP7702)).

Although the AirPrime WP7702 module has been certified, some parameters may have degraded if some basic precautions have not been followed (poor power supply, for example). This may not affect the functionality of the product, but the product may not comply with 3GPP specifications.

The following TX parameters can be checked using a Radio Communication tester:

- Phase & Frequency Error
- Output Power and Burst Time
- Output Spectrum (Modulation and Switching)

The following are available typical Radio Communication testers:

- Rohde & Schwarz: CMU200, CMW500
- Keysight (formerly Agilent): 8960
- Anritsu: MD8475

Because of the high prices associated with Radio Communication testers and the necessary RF know-how to perform simulations, customers can check their applications in the Semtech laboratories. Contact the Semtech support team for more information.

# 8: Reliability Specification

AirPrime WP7702 modules are tested against the Semtech Industrial Reliability Specification defined below.

## 8.1 Reliability Compliance

AirPrime WP7702 modules connected on a reliability test board are compliant with the requirements in [Table 8-1](#).

**Table 8-1: Standards Conformity**

Abbreviation	Definition
IEC	International Electrotechnical Commission
ISO	International Organization for Standardization

## 8.2 Reliability Prediction Model

### 8.2.1 Life Stress Test

The following tests the AirPrime WP7702 module's product performance.

**Table 8-2: Life Stress Test**

Designation	Condition
Performance Test PT3T & PTRT  	Standard: N/A
	Special conditions: <ul style="list-style-type: none"> <li>▪ Temperature:               <ul style="list-style-type: none"> <li>• Class A: -30°C to +70°C</li> <li>• Class B: -40°C to +85°C</li> <li>• Rate of temperature change: <math>3 \pm 0.6^\circ\text{C}/\text{min}</math></li> </ul> </li> <li>▪ Recovery time: 3 hours</li> </ul>
	Operating conditions: Powered
	Duration: 14 days

## 8.2.2 Environmental Resistance Stress Tests

The following tests the AirPrime WP7702 module's resistance to extreme temperature.

**Table 8-3: Environmental Resistance Stress Tests**

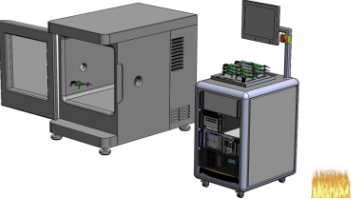
Designation	Condition
Cold Test Active COTA  	Standard: IEC 680068-2-1, Test ad
	Special conditions: <ul style="list-style-type: none"> <li>▪ Temperature: <math>-40^{\circ}\text{C}</math></li> <li>▪ Temperature variation: <math>1^{\circ}\text{C}/\text{min}</math></li> </ul>
	Operating conditions: Powered ON with a power cycle of 1 minute ON and 2 minutes OFF
	Duration: 3 days
Resistance to Heat Test RH  	Standard: IEC 680068-2-2, Test Bb
	Special conditions: <ul style="list-style-type: none"> <li>▪ Temperature: <math>+85^{\circ}\text{C}</math></li> <li>▪ Temperature variation: <math>1^{\circ}\text{C}/\text{min}</math></li> </ul>
	Operating conditions: Powered ON with a power cycle of 15 minutes ON and 15 minutes OFF
	Duration: 50 days

## 8.2.3 Corrosive Resistance Stress Tests

The following tests the AirPrime WP7702 module's resistance to corrosive atmosphere.

**Table 8-4: Corrosive Resistance Stress Tests**

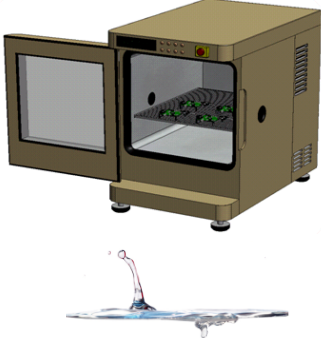
Designation	Condition
Humidity Test HUT  	Standard: IEC 60068-2-3, Test Ca
	Special conditions: <ul style="list-style-type: none"> <li>▪ Temperature: <math>+65^{\circ}\text{C}</math></li> <li>▪ RH: 95%</li> <li>▪ Temperature variation: <math>3 \pm 0.6^{\circ}\text{C}/\text{min}</math></li> </ul>
	Operating conditions: Powered ON with a power cycle of 15 minutes ON and 15 minutes OFF
	Duration: 10 days

**Table 8-4: Corrosive Resistance Stress Tests (Continued)**

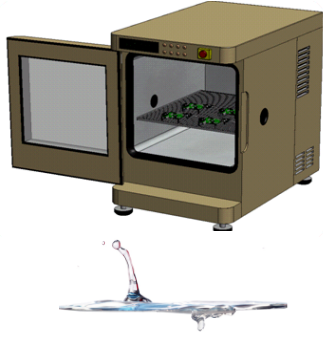
Designation	Condition
Component Solder Wettability CSW 	Standard: JESD22-B102, Method 1/Condition C, Solderability Test Method
	Special conditions: <ul style="list-style-type: none"> <li>Test method: Dip and Look Test with Steam preconditioning 8 h ± 15 min. Dip for 5 +0/-0.5 seconds</li> </ul>
	Operating conditions: Unpowered
	Duration: 1 day
Moist Heat Cyclic Test MHCT 	Standard: IEC 60068-2-30, Test Db
	Special conditions: <ul style="list-style-type: none"> <li>Upper temperature: +40 ± 2 °C</li> <li>Lower temperature: +23 ± 5 °C</li> <li>RH:                             <ul style="list-style-type: none"> <li>At upper temperature: 93%</li> <li>At lower temperature: 95%</li> </ul> </li> <li>Number of cycles: 21 (1 cycle/24 hours)</li> <li>Temperature variation: 3 ± 0.6 °C/min</li> </ul>
	Operating conditions: Powered ON for 15 minutes during each 3 hours ramp up and 3 hours ramp down (in middle) for every cycle
	Duration: 21 days

## 8.2.4 Thermal Resistance Cycle Stress Tests

The following tests the AirPrime WP7702 module's resistance to extreme temperature cycling.

**Table 8-5: Thermal Resistance Cycle Stress Tests**

Designation	Condition
Thermal Shock Test TSKT 	Standard: IEC 60068-2-14, Test Na
	Special conditions: <ul style="list-style-type: none"> <li>Temperature: -30 °C to +80 °C</li> <li>Temperature variation: 6–30 s</li> <li>Number of cycles: 600</li> <li>Dwell time: 10 minutes</li> </ul>
	Operating conditions: Unpowered
	Duration: 9 days

Table 8-5: Thermal Resistance Cycle Stress Tests (Continued)

Designation	Condition
Temperature Change TCH 	Standard: IEC 60068-2-14, Test Nb
	Special conditions: Temperature: -40°C to +90°C Temperature variation: $3 \pm 0.6^\circ\text{C}/\text{min}$ Number of cycles: 400 Dwell time: 10 minutes
	Operating conditions: Unpowered
	Duration: 29 days

## 8.2.5 Mechanical Resistance Stress Tests

The following tests the AirPrime WP7702 module's resistance to vibrations and mechanical shocks.

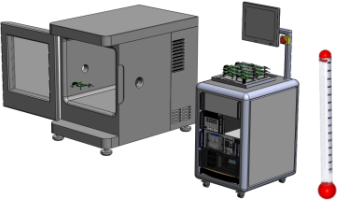
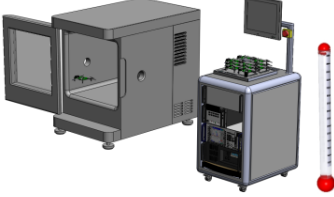
Table 8-6: Mechanical Resistance Stress Tests

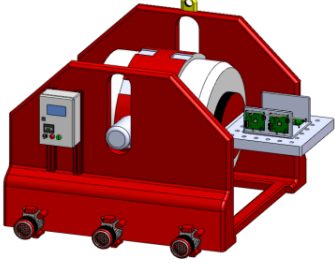
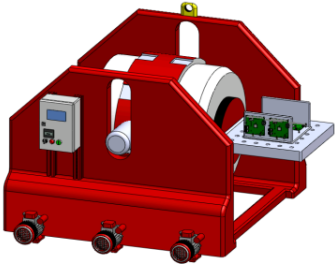
Designation	Condition
Sinusoidal Vibration Test SVT 	Standard: IEC 60068-2-6, Test Fc
	Special conditions: <ul style="list-style-type: none"> <li>▪ Frequency range: 16 Hz to 1000 Hz</li> <li>▪ Displacement: 0.35 mm (peak-peak)</li> <li>▪ Acceleration:               <ul style="list-style-type: none"> <li>• 5 g from 16 to 62 Hz</li> <li>• 3 g from 62 to 200 Hz</li> <li>• 1 g from 200 to 1000 Hz</li> </ul> </li> <li>▪ Sweep rate: 1 octave/minute</li> <li>▪ Number of sweeps: 20 sweeps/axis</li> <li>▪ Sweep direction: <math>\pm X, \pm Y, \pm Z</math></li> </ul>
	Operating conditions: Unpowered
	Duration: 2 days
Random Vibration Test RVT 	Standard: IEC 60068-2-64, Test Fh
	Special conditions: <ul style="list-style-type: none"> <li>▪ Frequency range: 10 Hz to 2000 Hz</li> <li>▪ Power Spectral Density in <math>[(\text{m}/\text{s}^2)^2/\text{Hz}]</math> <ul style="list-style-type: none"> <li>• 0.1 <math>\text{g}^2/\text{Hz}</math> at 10 Hz</li> <li>• 0.01 <math>\text{g}^2/\text{Hz}</math> at 250 Hz</li> <li>• 0.005 <math>\text{g}^2/\text{Hz}</math> at 1000 Hz</li> <li>• 0.005 <math>\text{g}^2/\text{Hz}</math> at 2000 Hz</li> </ul> </li> <li>▪ Peak factor: 3</li> <li>▪ Duration per axis: 1 hr/axis</li> </ul>
	Operating conditions: Unpowered
	Duration: 1 day

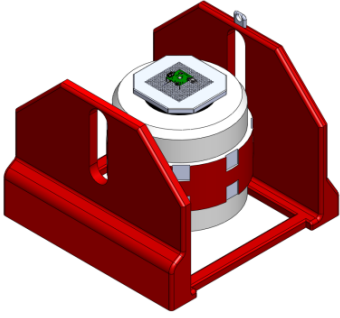
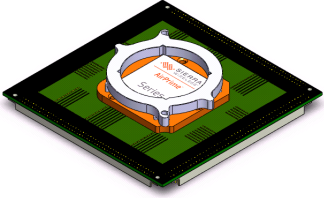

**Table 8-6: Mechanical Resistance Stress Tests (Continued)**

Designation	Condition
Mechanical Shock Test MST 	Standard: IEC 60068-2-27, Test Ea
	Special conditions: <ul style="list-style-type: none"> <li>▪ Shock Test 1:                             <ul style="list-style-type: none"> <li>• Wave form: Half sine</li> <li>• Peak acceleration: 30 g</li> <li>• Duration: 11 ms</li> <li>• Number of shocks: 8</li> <li>• Direction: ± X, ± Y, ± Z</li> </ul> </li> <li>▪ Shock Test 2:                             <ul style="list-style-type: none"> <li>• Wave form: Half sine</li> <li>• Peak acceleration: 100 g</li> <li>• Duration: 6 ms</li> <li>• Number of shocks: 3</li> <li>• Direction: ± X, ± Y, ± Z</li> </ul> </li> </ul>
	Operating conditions: Unpowered
	Duration: 72 hours

## 8.2.6 Handling Resistance Stress Tests

The following tests the AirPrime WP7702 module's resistance to handling malfunctions and damage.

**Table 8-7: Handling Resistance Stress Tests**

Designation	Condition
ESDC Test 	Standard: JESD22-A114, JESD22-A115, JESD22-C101
	Special conditions: <ul style="list-style-type: none"> <li>▪ HBM (Human Body Model): 1 kV (Class 1C)</li> <li>▪ MM (Machine Model): 100 V</li> <li>▪ CDM (Charged Device Model): 500 V (Class IV)</li> </ul>
	Operating conditions: Powered
	Duration: 3 days
Free Fall Test FFT 1 	Standard: IEC 60068-2-32, Test Ed
	Special conditions: <ul style="list-style-type: none"> <li>▪ Number of drops: 2 drops per unit</li> <li>▪ Height: 1 m</li> </ul>
	Operating conditions: Unpowered
	Duration: 6 hours

# 9: Approval

## 9.1 Disposing of the Product

This electronic product is subject to the EU Directive 2012/19/EU for Waste Electrical and Electronic Equipment (WEEE). As such, this product must not be disposed of at a municipal waste collection point. Please refer to local regulations for directions on how to dispose of this product in an environmental friendly manner.

## 9.2 Important Notice

Due to the nature of wireless communications, transmission and reception of data can never be guaranteed. Data may be delayed, corrupted (i.e., have errors) or be totally lost. Although significant delays or losses of data are rare when wireless devices such as the Semtech module are used in a normal manner with a well-constructed network, the Semtech module should not be used in situations where failure to transmit or receive data could result in damage of any kind to the user or any other party, including but not limited to personal injury, death, or loss of property. Semtech accepts no responsibility for damages of any kind resulting from delays or errors in data transmitted or received using the Semtech module, or for failure of the Semtech module to transmit or receive such data.

## 9.3 Safety and Hazards

Do not operate your AirPrime WP7702 embedded module:

- In areas where blasting is in progress
- Where explosive atmospheres may be present including refueling points, fuel depots, and chemical plants
- Near medical equipment, life support equipment, or any equipment which may be susceptible to any form of radio interference.

In such areas, the AirPrime WP7702 module **MUST BE IN AIRPLANE MODE OR POWERED OFF**. Otherwise, the AirPrime WP7702 module can transmit signals that could interfere with this equipment.

In an aircraft, the AirPrime WP7702 module **MUST BE IN AIRPLANE MODE OR POWERED OFF**. Otherwise, the AirPrime WP7702 module can transmit signals that could interfere with various onboard systems and may be dangerous to the operation of the aircraft or disrupt the cellular network. Use of a cellular phone in an aircraft is illegal in some jurisdictions. Failure to observe this instruction may lead to suspension or denial of cellular telephone services to the offender, or legal action or both.

Some airlines may permit the use of cellular phones while the aircraft is on the ground and the door is open. The AirPrime WP7702 module may be used normally at this time.

## 9.4 Compliance Acceptance and Certification

The AirPrime WP7702 is designed to be compliant with the 3GPP Release 8 UTRA and Release 10 E-UTRA Specifications for Mobile Terminated Equipment.

Final regulatory and operator certification requires regulatory agency testing and approval with the fully integrated UE host device incorporating the AirPrime WP7702 module.

The OEM host device and, in particular, the OEM antenna design and implementation will affect the final product functionality, RF performance, and certification test results.

*Note: Tests that require features not supported by the AirPrime WP7702 (as defined by this document) are not supported.*

## 9.5 Certification Compliance

### 9.5.1 Important Compliance Information for North America

The AirPrime WP7702 module has been granted modular approval for mobile applications under FCC ID: N7NWP77B and IC: 2417C-WP77B

Integrators may use the AirPrime WP7702 module in their final products without additional FCC/IC (Industry Canada) certification if they meet the following conditions. Otherwise, additional FCC/IC approvals must be obtained.

1. The end product must use the RF trace design approved with the AirPrime WP7702 module. The Gerber file of the trace design can be obtained from Semtech upon request.
2. At least 20 cm separation distance between the antenna and the user’s body must be maintained at all times.
3. To comply with FCC/IC regulations limiting both maximum RF output power and human exposure to RF radiation, the maximum antenna gain including cable loss in a mobile-only exposure condition must not exceed the limits stipulated in [Table 9-1](#) on page 96.

**Table 9-1: WP7702 Antenna Gain Specifications**

Technology	Band	Frequency (MHz)	Maximum antenna gain (dBi)	
			Standalone	Collocated <sup>a</sup>
LTE	2	1850–1910	9	8
	4 <sup>b</sup>	1710–1755	6	6
	5	824–849	7	6
	12	699–716	6	6
	13	777–787	6	6
	17 <sup>c</sup>	704–716	6	6
	26	814–849	7	6
GPRS/EDGE	GSM 850	824–849	4	3
	PCS 1900	1850–1910	3	3

- a. Antenna gain limit when module collocated with Wi-Fi/Wimax/BT radios
- b. B4—CAT-M1 only
- c. B17—CAT-NB1 only

4. The AirPrime WP7702 module may transmit simultaneously with other collocated radio transmitters within a host device, provided the following conditions are met:
  - Each collocated radio transmitter has been certified by FCC/IC for mobile application.
  - At least 20 cm separation distance between the antennas of the collocated transmitters and the user’s body must be maintained at all times.

- The output power of a collocated transmitter must not exceed the EIRP limit stipulated in [Table 9-2](#) on page 97.

**Table 9-2: WP7702 Collocated Radio Transmitter Specifications**

Device	Technology	Frequency (MHz)	EIRP Limit (dBm)
Collocated transmitters <sup>a</sup>	WLAN	2400–2500	25
		5150–5850	27
	WiMAX	2300–2400	25
		2500–2700	25
		3300–3800	25
	BT	2400–2500	15

a. Valid collocated transmitter combinations: WLAN+BT; WiMAX+BT.  
(WLAN+WiMAX+BT is not permitted.)

5. A label must be affixed to the outside of the end product into which the AirPrime WP7702 module is incorporated, with a statement similar to the following:  
**This device contains FCC ID: N7NWP77B / IC:2417C-WP77B.**
6. A user manual with the end product must clearly indicate the operating requirements and conditions that must be observed to ensure compliance with current FCC/IC RF exposure guidelines.

The end product with an embedded AirPrime WP7702 module may also need to pass the FCC Part 15 unintentional emission testing requirements and be properly authorized per FCC Part 15.

*Note: If this module is intended for use in a portable device, you are responsible for separate approval to satisfy the SAR requirements of FCC Part 2.1093 and IC RSS-102.*

## 9.5.2 ANATEL (Brazil)

The AirPrime WP7702 module has been approved by ANATEL in Brazil.



# 10: Pinout

The system interface of the AirPrime WP7702 is through the LGA pattern on the bottom of the PCB.

AirPrime WP7702 pins are divided into three functional categories:

- Core functions and associated pins — Cover all the mandatory features for M2M connectivity and will be available by default across all CF3 family of modules. These Core functions are always available and always at the same physical pin locations. A customer platform using only these functions and associated pins is guaranteed to be forward and/or backward compatible with the next generation of CF3 modules.
- Extension functions and associated pins — Bring additional capabilities to the customer. Whenever an Extension function is available on a module, it is always at the same pin location.
- Custom functions and associated pins — These are module-specific and make use of specific chipset functions and I/Os.

**Warning:** *Custom features should be used with caution as there is no guarantee that the custom functions available on a given module will be available on other CF3 modules.*

Pins marked as "Leave open" or "Reserved" should not be used or connected.

# Pin Configuration

Figure 10-1 illustrates the pin configuration of the AirPrime WP7702 module.

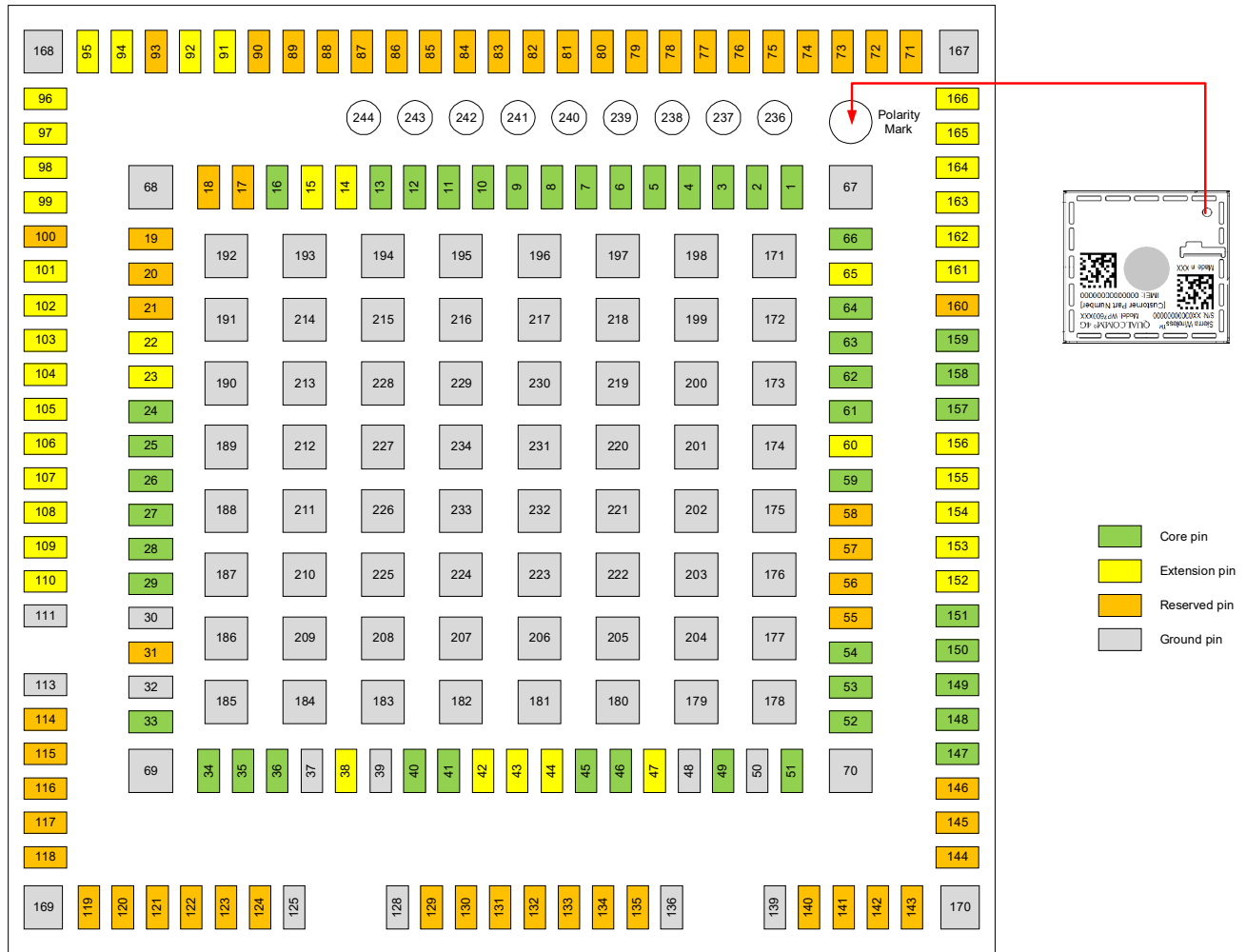

Figure 10-1: Pin Configuration (Top View)

## Pin Description

Table 10-1 on page 100 lists detailed information for the LGA pins.

Note: Some pin numbers (112, 126, 127, 137, 138, 235) do not appear in this table because there are no corresponding pads on the module's PCB.

Table 10-1: Pin Definitions

Pin	Signal name	Group	I/O <sup>a</sup>	Voltage	PU/ PD <sup>b</sup>	Active	If unused	Function	Type
1	I2C1_CLK	I2C	I/O	1.8V	PU		Leave open	I <sup>2</sup> C clock	Core
2	UART1_RI <sup>c e</sup>	UART1	O	1.8V		H	Leave open	UART1 Ring indicator	Core
3	UART1_RT5 <sup>c</sup>	UART1	I	1.8V		L	Leave open	UART1 Request to send	Core
4	UART1_CTS <sup>c</sup>	UART1	O	1.8V		L	Leave open	UART1 Clear to send	Core
5	UART1_TX <sup>c</sup>	UART1	I	1.8V			Leave open	UART1 Transmit data	Core
6	UART1_RX <sup>c</sup>	UART1	O	1.8V			Leave open	UART1 Receive data	Core
7	UART1_DTR <sup>c d f</sup>	UART1	I	1.8V		L	Leave open	UART1 Data terminal ready	Core
8	UART1_DCD <sup>c d e</sup>	UART1	O	1.8V		L	Leave open	UART1 Data carrier detect	Core
9	UART1_DSR <sup>c d e</sup>	UART1	O	1.8V		L	Leave open	UART1 Data set ready	Core
10	GPIO2 <sup>f</sup>	GPIO	I/O	1.8V	NP		Leave open	General purpose I/O	Core
11	RESET_IN_N	Control signal	I	1.8V	PU	L	Leave open	Input reset signal	Core
12	USB_D-	USB	I/O				Leave open	USB Data negative	Core
13	USB_D+	USB	I/O				Leave open	USB Data positive	Core
14	HSIC_DATA <sup>g</sup>	HSIC	I/O	1.2V			Leave open	High Speed Inter-Chip Data	Extension
15	HSIC_STRB <sup>g</sup>	HSIC	I/O	1.2V			Leave open	High Speed Inter-Chip Strobe	Extension
16	USB_VBUS	USB	I	5V or VBAT_BB			Optional connection (If USB interface is required then connect to USB_VBUS or (if unavailable) VBAT_BB, otherwise leave open.)	USB power supply	Core
17–20	Reserved	No Connection					See footnote <sup>h</sup> .		Extension
21	Reserved	No Connection					Leave open		Extension

Table 10-1: Pin Definitions (Continued)

Pin	Signal name	Group	I/O <sup>a</sup>	Voltage	PU/ PD <sup>b</sup>	Active	If unused	Function	Type
22	SYS_CLK	Clock	O				Leave open	19 MHz digital clock output	Extension
23	SLEEP_CLK	Clock	O				Leave open	32.768 kHz digital clock output	Extension
24	ADC1	ADC	I				Leave open	Analog to digital conversion	Core
25	ADC0	ADC	I				Leave open	Analog to digital conversion	Core
26	UIM1_VCC	UIM1	O	1.8V/3V			Mandatory connection	1.8V/3V UIM1 Power supply	Core
27	UIM1_CLK	UIM1	O	1.8V/3V			Mandatory connection	UIM1 Clock	Core
28	UIM1_DATA	UIM1	I/O	1.8V/3V			Mandatory connection	UIM1 Data	Core
29	UIM1_RESET_N	UIM1	O	1.8V/3V		L	Mandatory connection	UIM1 Reset	Core
30	GND	Ground	0V	0V			Mandatory connection	Ground	Extension
31	Reserved	No Connection					See footnote <sup>h</sup> .		Extension
32	GND	Ground	0V	0V			Mandatory connection	Ground	Extension
33	PCM_OUT <sup>i</sup>	PCM	O	1.8V			Leave open	PCM data out	Core
	I2S_OUT <sup>i</sup>	I2S	O	1.8V			Leave open	I2S data out	
34	PCM_IN <sup>i</sup>	PCM	I	1.8V			Leave open	PCM data in	Core
	I2S_IN <sup>i</sup>	I2S	I	1.8V			Leave open	I2S data in	
35	PCM_SYNC <sup>i</sup>	PCM	Pri: I/O Aux: O	1.8V			Leave open	PCM sync	Core
	I2S_WS <sup>i</sup>	I2S	O	1.8V			Leave open	I2S word select	
36	PCM_CLK <sup>i</sup>	PCM	Pri: I/O Aux: O	1.8V			Leave open	PCM clock	Core
	I2S_CLK <sup>i</sup>	I2S	O	1.8V			Leave open	I2S clock	
37	GND	RF	0V	0V			Mandatory connection	GNSS antenna ground	Core
38	RF_GNSS <sup>j</sup>	RF					Mandatory connection	RF GNSS input	Extension
39	GND	RF	0V	0V			Mandatory connection	GNSS antenna ground	Core
40	GPIO7	GPIO	I/O	1.8V	NP		Leave open	General purpose I/O	Core
41	GPIO8	GPIO	I/O	1.8V	NP		Leave open	General purpose I/O	Core
42	DR_SYNC <sup>j</sup>	GPS	O	1.8V			Leave open	GPS dead reckoning sync	Extension

Table 10-1: Pin Definitions (Continued)

Pin	Signal name	Group	I/O <sup>a</sup>	Voltage	PU/ PD <sup>b</sup>	Active	If unused	Function	Type
43	EXT_GPS_LNA_EN	Control signal	O	1.8V		H	Leave open	External GNSS LNA enable	Extension
44	GPIO13	GPIO	I/O	1.8V	NP		Leave open	General purpose I/O	Extension
45	VGPI0	Voltage reference	O	1.8V			Leave open	GPIO voltage output	Core
46	GPIO6 <sup>k</sup>	GPIO	I/O	1.8V	NP		Leave open	General purpose I/O	Core
	RESET_OUT_N	Control signal	O	1.8V	PD	L	Leave open	Reset	Core
47	TP1 (Boot pin)	Boot	I	1.8V		L	Mandatory test point	Test point 1 <ul style="list-style-type: none"> <li>▪ 0 — Download mode</li> <li>▪ Open — Normal mode</li> </ul>	Extension
48	GND	RF	0V	0V			Mandatory connection	Main antenna ground	Core
49	RF_MAIN	RF					Mandatory connection	Main RF antenna	Core
50	GND	RF	0V	0V			Mandatory connection	Main antenna ground	Core
51	SPI1_MRDY	SPI1	O	1.8V			Leave open	SPI Master Ready	Core
52	SPI1_MISO	SPI1	I	1.8V			Leave open	SPI Master Input/Slave Output (output from slave)	Core
53	SPI1_CLK	SPI1	O	1.8V			Leave open	SPI serial clock (output from Master)	Core
54	SPI1_MOSI	SPI1	O	1.8V			Leave open	SPI Master Output/Slave Input (output from master)	Core
55	Reserved	No Connection					See footnote <sup>l</sup> .		Core
56	Reserved	No Connection					See footnote <sup>l</sup> .		Core
57	Reserved	No Connection					See footnote <sup>l</sup> .		Core
58	Reserved	No Connection					See footnote <sup>l</sup> .		Core
59	POWER_ON_N	Control	I	1.8V	PU	L	Mandatory connection	Power On control signal	Core
60	TX_ON	Indication	O	1.8V		H	Leave open	Tx activity indicator	Extension
61	VBAT_RF	Power	I	3.4V (min) 3.7V (typ) 4.3V (max)			Mandatory connection	RF power supply (see <a href="#">Power Supply Ratings</a> on page 22)	Core
62	VBAT_RF	Power	I	3.4V (min) 3.7V (typ) 4.3V (max)			Mandatory connection	RF power supply (see <a href="#">Power Supply Ratings</a> on page 22)	Core

Table 10-1: Pin Definitions (Continued)

Pin	Signal name	Group	I/O <sup>a</sup>	Voltage	PU/ PD <sup>b</sup>	Active	If unused	Function	Type
63	VBAT_BB	Power	I	3.4V (min) 3.7V (typ) 4.3V (max)			Mandatory connection	Baseband power supply (see <a href="#">Power Supply Ratings</a> on page 22)	Core
64	UIM1_DET	UIM1		1.8V			Mandatory connection	Detect UIM1 insertion/removal. (Pin must be open to detect the UIM, or grounded if no UIM is present.)	Core
65	GPIO4	GPIO	I/O	1.8V	NP		Leave open	Reserved	Extension
66	I2C1_Data	I2C	I/O	1.8V	PU		Leave open	I <sup>2</sup> C data	Core
67–70	GND	Ground	0V	0V			Mandatory connection	Ground	Core
71–90	Reserved	No Connection					See footnote <sup>h</sup> .		
91	USB_ID	USB	I				Leave open	Reserved for use with USB OTG	Extension
92	GPIO38 <sup>m,n</sup>	GPIO	I/O	1.8V	NP		Leave open	General purpose I/O	Extension
93	Reserved	No Connection					See footnote <sup>h</sup> .		
94	GPIO40 <sup>m</sup>	GPIO	I/O	1.8V	NP		Leave open	General purpose I/O	Extension
95	GPIO41 <sup>m</sup>	GPIO	I/O	1.8V	NP		Leave open	General purpose I/O	Extension
96	UART2_TX <sup>c</sup>	UART2	I	1.8V			Leave open	UART2 Transmit data	Extension
97	UART2_RX <sup>c</sup>	UART2	O	1.8V			Leave open	UART2 Receive data	Extension
98	UART2_RTS <sup>c</sup>	UART2	I	1.8V			Leave open	UART2 Request To Send	Extension
99	UART2_CTS <sup>c</sup>	UART2	O	1.8V			Leave open	UART2 Clear To Send	Extension
100	Reserved	No Connection					See footnote <sup>h</sup> .		
101	GPIO35	GPIO	I/O	1.8V	NP		Leave open	General purpose I/O	Extension
102	GPIO36 <sup>m,n</sup>	GPIO	I/O	1.8V	NP		Leave open	General purpose I/O	Extension
103	GPIO37 <sup>m</sup>	GPIO	I/O	1.8V	NP		Leave open	General purpose I/O	Extension
104	GPIO32	GPIO	I/O	1.8V	NP		Leave open	General purpose I/O	Extension
105	GPIO33	GPIO	I/O	1.8V	NP		Leave open	General purpose I/O	Extension
106	WWAN_LED_N	Indication	O	VBAT_BB <sup>o</sup>		L	Leave open		Extension
107	ADC2 <sup>p</sup>	ADC	I				Leave open		Extension
108	ADC3 <sup>p</sup>	ADC	I				Leave open		Extension
109	GPIO42 <sup>f</sup>	GPIO	I/O	1.8V	NP		Leave open	General purpose I/O	Extension
110	WAKE_ON_WWAN	Indication	O	1.8V		H	Leave open	Driven high to wake the host when specific events occur.	Extension

Table 10-1: Pin Definitions (Continued)

Pin	Signal name	Group	I/O <sup>a</sup>	Voltage	PU/ PD <sup>b</sup>	Active	If unused	Function	Type
111	GND	Ground	0V	0V			Mandatory connection	Ground	Core
113	GND	Ground	0V	0V			Mandatory connection	Ground	Core
114 – 124	Reserved	No Connection					See footnote <sup>h</sup> .		
125	GND	RF	0V	0V			Mandatory connection	GNSS antenna ground	Core
128	GND	RF	0V	0V			Mandatory connection	GNSS antenna ground	Core
129 – 135	Reserved	No Connection					See footnote <sup>h</sup> .		
136	GND	RF	0V	0V			Mandatory connection	Main antenna ground	Core
139	GND	RF	0V	0V			Mandatory connection	Main antenna ground	Core
140 – 146	Reserved	No Connection					See footnote <sup>h</sup> .		
147	GPIO21 <sup>f</sup>	GPIO	I/O	1.8V	NP		Leave open	General purpose I/O	Core
148	GPIO22	GPIO	I/O	1.8V	NP		Leave open	General purpose I/O	Core
149	GPIO23	GPIO	I/O	1.8V	NP		Leave open	General purpose I/O	Core
150	GPIO24	GPIO	I/O	1.8V	NP		Leave open	General purpose I/O	Core
151	W_DISABLE_N	Control	I	1.8V		L		Wireless disable (main RF radio)	Core
152	SAFE_PWR_REMOVE	Indication	O	1.8V		H	Leave open	Indicate to host that Main DC power can be removed	Extension
153	ANT_CNTL0	Antenna control	O	1.8V			Leave open		Extension
	GPIO28 <sup>g</sup>	GPIO	I/O	1.8V			Leave open	General purpose I/O	Extension
154	ANT_CNTL1	Antenna control	O	1.8V			Leave open		Extension
	GPIO29 <sup>g</sup>	GPIO	I/O	1.8V			Leave open	General purpose I/O	Extension
155	ANT_CNTL2	Antenna control	O	1.8V			Leave open		Extension
	GPIO30 <sup>g</sup>	GPIO	I/O	1.8V			Leave open	General purpose I/O	Extension
156	ANT_CNTL3	Antenna control	O	1.8V			Leave open		Extension
	GPIO31 <sup>g</sup>	GPIO	I/O	1.8V			Leave open	General purpose I/O	Extension

Table 10-1: Pin Definitions (Continued)

Pin	Signal name	Group	I/O <sup>a</sup>	Voltage	PU/ PD <sup>b</sup>	Active	If unused	Function	Type
157	VBAT_RF	Power	I	3.4V (min) 3.7V (typ) 4.3V (max)			Optional connection	RF power supply (see <a href="#">Power Supply Ratings</a> on page 22)	Core
158	VBAT_BB	Power	I	3.4V (min) 3.7V (typ) 4.3V (max)			Optional connection	Baseband power supply (see <a href="#">Power Supply Ratings</a> on page 22)	Core
159	GPIO25	GPIO	I/O	1.8V	NP		Leave open	General purpose I/O	Core
160	Reserved	No Connection					See footnote <sup>h</sup> .		
161	SDIO_CMD	SDIO	O	1.8V/2.85V			Leave open	SDIO command	Extension
162	SDIO_CLK	SDIO	O	1.8V/2.85V			Leave open	SDIO clock	Extension
163	SDIO_DATA_3	SDIO	I/O	1.8V/2.85V			Leave open	SDIO data bit 3	Extension
164	SDIO_DATA_2	SDIO	I/O	1.8V/2.85V			Leave open	SDIO data bit 2	Extension
165	SDIO_DATA_1	SDIO	I/O	1.8V/2.85V			Leave open	SDIO data bit 1	Extension
166	SDIO_DATA_0	SDIO	I/O	1.8V/2.85V			Leave open	SDIO data bit 0	Extension
167 – 234	GND	Ground	0V	0V			Mandatory connection	Ground	Core
236	Reserved <sup>f</sup>	No Connection					See footnote <sup>5</sup> .		
237	Reserved <sup>f</sup>	No Connection					See footnote <sup>5</sup>		
238	Reserved <sup>f</sup>	No Connection					See footnote <sup>5</sup>		
239	Reserved <sup>f</sup>	No Connection					See footnote <sup>5</sup>		
240	Reserved <sup>f</sup>	No Connection					See footnote <sup>5</sup>		
241	Reserved <sup>f</sup>	No Connection					See footnote <sup>5</sup>		
242	Reserved <sup>f</sup>	No Connection					See footnote <sup>5</sup>		
243	Reserved <sup>f</sup>	No Connection					See footnote <sup>5</sup>		
244	Reserved <sup>f</sup>	No Connection					See footnote <sup>5</sup>		

- Signal direction with respect to the module. Examples: UART1\_TX (pin 5) is an input from the module to the host; UART1\_RX (pin 6) is an output to the module from the host.
- NP—No Pull; PD—Pull Down; PU—Pull Up
- (UART signals only) Signals are named with respect to the host device. For example, UART1\_RX is the signal used by the host to receive data from the module.
- Software support for 8-wire UART1 will be available in a future firmware revision.
- Do not install external pull-up on this pin, otherwise the module will not boot.
- Wakeable GPIO. See [Wakeup Interrupt \(Sleep State\)](#) on page 63 for details.
- If HSIC bus is not used on the host application, refer to [HSIC Bus](#) on page 70 for recommended methods for disabling the interface.

## Product Technical Specification

---

- h. Pins are not connected internally, but are reserved for future use. Leave them unconnected to ensure compatibility with other Semtech CF3 modules.
- i. Firmware support for audio is not available.
- j. Support is SKU-dependent.
- k. Not available when used for RESET\_OUT\_N or external SIM multiplexer (AT!CUSTOM="EXTUIMSWITCHEN").
- l. Pins are reserved for future use. Leave them unconnected to ensure compatibility with other Semtech CF3 modules.
- m. Accessible via sysfs/Legato only.
- n. Can be configured as a wakeup trigger for ULPS. See [Power Consumption States](#) on page 25 for details.
- o. Maximum rating is VBAT\_BB + 0.5V, with maximum current sink capability of 300 mA.
- p. Wakeable ADC. See [Wakeup Events \(ULPS\)](#) on page 63 for details.
- q. This pin is available for use when configured using AT+WIOCFG.
- r. Accessibility restricted to soldered-down modules. Not available for socket-mounted modules.
- s. Reserved pins. No connect on the host platform.

# 11: Customization

Subject to commercial terms, Semtech can supply custom-configured modules to facilitate a carrier's network and performance requirements. Semtech also offers a standard configuration for each country.

Custom configurations are entered into a selector spreadsheet that Sierra supplies. A unique part number is assigned to each custom configuration to facilitate customer ordering.

**Table 11-1: Customizable Features**

Name	Description	Default
Display of IMSI	Display of International Mobile Subscriber Identity via AT+CIMI command	Display enabled
UART baud rate	Default UART speed	115200 bps
UART enabled	Defines whether UART port is enabled by default or not	UART disabled

# 12: Testing

## 12.1 Certification Testing

---

*Note: Typically, certification testing of your device with the integrated module is required one time only.*

---

The AirPrime WP7702 module has been certified as described in [Regulatory Compliance and Industry Certifications](#) on page 95.

When you produce a host device with a Semtech AirPrime embedded module, you must obtain certifications for the final product from appropriate regulatory bodies in the jurisdictions where it will be distributed.

The following are *some* of the regulatory bodies from which you may require certification — it is your responsibility to make sure that you obtain all necessary certifications for your product from these or other groups:

- FCC (Federal Communications Commission — [www.fcc.gov](http://www.fcc.gov))
- Industry Canada ([www.ic.gc.ca](http://www.ic.gc.ca))
- GCF (Global Certification Forum — [www.globalcertificationforum.org](http://www.globalcertificationforum.org)) outside of North America
- PTCRB (PCS Type Certification Review Board — [www.ptcrb.com](http://www.ptcrb.com)) in North America

## 12.2 Production Testing

---

*Note: Production testing typically continues for the life of the product.*

---

Production testing ensures that, for each assembled device, the module is installed correctly (I/O signals are passed between the host and module), and the antenna is connected and performing to specifications (RF tests).

Typical items to test include:

- Host connectivity
- Baseband (host/module connectors)
- RF assembly (Tx and/or Rx, as appropriate)
- Network availability
- Host/device configuration issues

---

*Note: The number and types of tests to perform are **your** decision — the tests listed in this section are guidelines only. Make sure that the tests you perform exercise functionality to the degree that **your** situation requires.*

---

Use an appropriate test station and use AT commands to control the integrated module.

---

*Note:*

- *Your test location must be protected from ESD to avoid interference with the module and antenna(s), assuming that your test computer is in a disassembled state. Also, consider using an RF shielding box — local government regulations may prohibit unauthorized transmissions.*
  - *The tests described in this chapter are done using a Linux O/S (e.g. Ubuntu 12.04).*
-

---

## 12.3 Functional Production Test

This section presents a suggested procedure for performing a basic manual functional test on a laboratory bench using an AirPrime WP7702 module and a hardware development kit. When you have become familiar with the testing method, use it to develop your own automated production testing procedures.

### 12.3.1 Suggested Production Tests

Consider the following tests when you design your production test procedures for devices with the AirPrime module installed.

- Visual check of the module's connectors and RF assemblies
- Module is operational
- USB connection is functional
- LED is functional
- Power on/off
- Firmware revision check
- Rx tests on main and auxiliary paths
- Tx test

### 12.3.2 Production Test Procedure

The following is a suggested test plan — you must decide which tests are appropriate for your product. You may wish to add additional tests that more fully exercise the capabilities of your product.

Using an appropriate test station, and referring to the appropriate AT command references:

1. Visually inspect the module for obvious defects (such as tainted or damaged shields) before installing it in the test station.
2. Ensure that the module is powered off (no voltage on VBAT\_BB/VBAT\_RF) before beginning your tests.
3. Determine whether any USB devices are currently connected to the computer:
  - a. Open a shell window and enter the command **ls /dev/tty/USB\***.
  - b. Record the `ttyUSBn` values that are returned; these are the currently connected USB devices. If the command returns "no such file or directory", there are no devices currently connected.
4. Provide power to the module (voltage on VBAT\_BB/VBAT\_RF).
5. Test POWER\_ON\_N — Turn on the module by driving POWER\_ON\_N low, as shown in [Figure 4-1](#) on page 57.
6. Test USB functionality — Check for USB enumeration.

Enter the command **ls /dev/tty/USB\*** and then record and compare the results with those from [Step 3](#). If there are any new `ttyUSBn` devices, then the module has enumerated successfully. (The AT port is usually the *last* new device.)
7. Make sure your module is connected and running, and then establish contact with the module:

Use a terminal emulation/communications program such as `minicom` to connect over the device handle for AT commands (see listings in [Step 6](#)):

---

*Note: If the command "minicom" is not found, then use a different program, or download minicom and repeat this step. See [Downloading and Configuring minicom for Linux Systems](#) on page 110 for details.*

---

- i. Start minicom:
  - First use of the module: From the command line, type `minicom -s`. (The ‘-s’ switch shows the configuration menu.)
  - Subsequent uses: From the command line, type `minicom`. (The ‘-s’ switch is assumed.)

The minicom configuration details appear and the message OK appears when the connection is established.

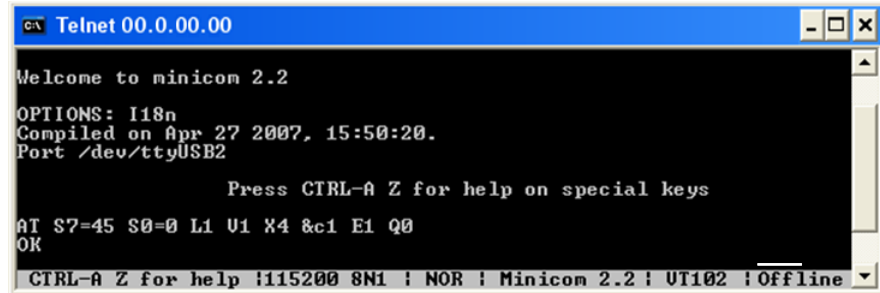

```
CA Telnet 00.0.00.00
Welcome to minicom 2.2
OPTIONS: I18n
Compiled on Apr 27 2007, 15:50:20.
Port /dev/ttyUSB2

          Press CTRL-A Z for help on special keys

AT S7=45 S0=0 L1 U1 X4 &c1 E1 Q0
OK
CTRL-A Z for help !115200 8N1 ! NOR ! Minicom 2.2 ! UT102 ! Offline
```

8. Display the firmware version:
  - `ATI`
9. Unlock the extended AT command set. (Note: Use `ATI!ENTERCND?` to check command syntax, which is SKU-dependent.):
  - `ATI!ENTERCND=<password>`
10. Test the LED — Visually confirm that the LED turns on and off using:
  - `AT!LDTEST=0,1` (LED on)
  - `AT!LDTEST=0,0` (LED off)
11. Put the module in diagnostic/factory test mode:
  - `ATI!DAFTMACT`
12. Communicate with the SIM using `AT+CPIN` or `AT+CIMI`.
13. Test RF transmission, if desired:
  - (UMTS) See [GPRS/EDGE RF Transmission Path Test](#) on page 111.
  - (LTE) See [LTE RF Transmission Path Test](#) on page 113.
14. Test RF reception, if desired:
  - (UMTS) See [GPRS/EDGE RF Receive Path Test](#) on page 115.
  - (LTE) See [LTE RF Receive Path Test](#) on page 117.
15. Test standalone GNSS functionality — See [GNSS RF Receive Path Test](#) on page 119.
16. Remove power from the module.

### 12.3.2.1 Downloading and Configuring minicom for Linux Systems

---

*Note: This procedure is for Ubuntu systems. If you are using a different Linux distribution, use the appropriate commands for your system to download minicom.*

---

To download and configure minicom in a Ubuntu system:

1. Download and install minicom — enter the following command:  
`sudo apt-get install minicom`

---

*Note: To install minicom, you must have root access, or be included in the sudoers list.*

---

2. When prompted, enter your user password to begin the download and installation. When minicom is installed, the shell prompt appears.
3. Configure minicom to communicate with your module:
  - a. Start minicom with the following command:  

```
minicom -s
```
4. Use the down-arrow key to select the **Serial port setup** option.
5. Refer to [Step 6](#) on page 109 to identify the device file handle (/dev/ttyUSBn) used for AT commands.
6. Indicate the file handle to use for AT commands—Enter A and then replace the serial device string with the AT file handle.
7. Press **Enter** twice.
8. Use the down-arrow key to select **Save setup as dfl.**
9. Select **Exit.**

## 12.4 GPRS / EDGE RF Transmission Path Test

*Note: This procedure segment is performed in [Step 13](#) of the [Production Test Procedure](#) on page 109.*

The suggested test procedure that follows uses the parameters in the following table.

**Table 12-1: Test Settings — AirPrime WP7702 GPRS / EDGE Transmission Path**

	Band	Band ID	Tx Channel <sup>a</sup>
850 MHz	GSM 850	18	190
900 MHz	E-GSM 900	10	62
1800 MHz	DCS 1800	11	701
1900 MHz	PCS_1900	12	661

- a. Channel values shown are at the center of the corresponding bands.

*Note: This procedure describes steps using the 'Power Meter: Gigatronics 8651A" (with Option 12 and Power Sensor 80701A).*

To test the DUT's transmitter path:

1. Set up the power meter:

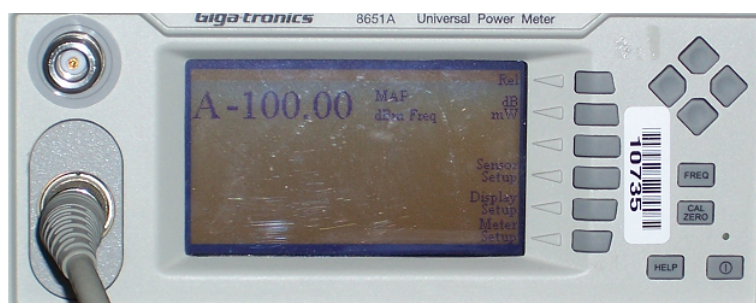

- a. Make sure the meter has been given sufficient time to warm up, if necessary, to enable it to take accurate measurements.
  - b. Zero-calibrate the meter.
  - c. Enable MAP mode.
2. Prepare the DUT using the following AT commands:
- a. **ATIINTERCND=<password>** (Unlock extended AT command set.)
  - b. **ATIDAFTMACT** (Enter test mode.)
  - c. **ATIRESET** (Reset the module.)  
(Note: Due to the limited memory footprint on the module's 9x06 chipset, the module must be reset after entering test mode in order to load the FTM memory partition.)
  - d. **ATIINTERCND=<password>** (Unlock extended AT command set.)
  - e. **ATIDAFTMACT** (Enter test mode.)
  - f. **ATIDASBAND=<bandValue>** (Set frequency band.)
    - See [Table 12-1](#) on page 111 for appropriate <bandValue> values
  - g. **ATIDASCHAN=<channel>** (Set modem channel)
    - See [Table 12-1](#) on page 111 for appropriate <channel> values
  - h. **ATIDAGSTXFRAME=0,1,3000,0** (Set Tx frame structure.)
  - i. **ATIDASTXON** (Turns on the transmit path.)
  - j. Offset the tracking (If necessary, repeat with different offsets until the desired frequency is obtained.)  
**ATIDASPDM=0,2240**
  - k. Take the measurement.
  - l. **ATIDASTXOFF** (Turn off the transmitter.)
3. Test limits — Run ten or more good DUTs through this test procedure to obtain a nominal output power value.
- Apply a tolerance of  $\pm 5$  to 6 dB to each measurement (assuming a good setup design).
  - Monitor these limits during mass-production ramp-up to determine if further adjustments are needed.
  - The transmit signal is bursted, so the transmit power will appear averaged on the power meter reading.

---

*Note: The module has a nominal output power of +23 dBm  $\pm 1$  dB in WCDMA mode. However, the value measured by the power meter is significantly influenced (beyond the stated  $\pm 1$  dB output power tolerance) by the test setup (host RF cabling loss, antenna efficiency and pattern, test antenna efficiency and pattern, and choice of shield box).*

---

---

*Note: When doing the same test over the air in an RF chamber, values are likely to be significantly lower.*

---

## 12.5 LTE RF Transmission Path Test

*Note: This procedure segment is performed in Step 13 of the Production Test Procedure on page 109.*

The suggested test procedure that follows uses the parameters in the following tables.

**Table 12-2: Test Settings — WP7702 LTE Transmission Path**

	<b>Band</b>	<b>Band ID</b>	<b>Channel<sup>a</sup></b>
2100 MHz	B1	34	18000
1900 MHz	B2	43	18900
1800 MHz	B3	44	19575
1700 MHz	B4 <sup>b</sup>	42	20175
850 MHz	B5	45	20525
900 MHz	B8	47	21625
700 MHz	B12	50	23095
700 MHz	B13	36	23230
700 MHz	B17 <sup>c</sup>	37	23790
850 MHz	B18	54	23925
850 MHz	B19	55	24075
800 MHz	B20	56	24300
1900 MHz	B26	62	26865
700 MHz	B28	64	27435

- a. Channel value used by the !DASCHAN command (!DASCHAN uses uplink (Tx) channel at the center of the corresponding band, for both Tx and Rx testing)
- b. B4 — CAT-M1 only
- c. B17 — CAT-NB1 only

*Note: This procedure describes steps using the 'Power Meter: Gigatronics 8651A' (with Option 12 and Power Sensor 80701A).*

To test the DUT's transmitter path:

1. Set up the power meter:

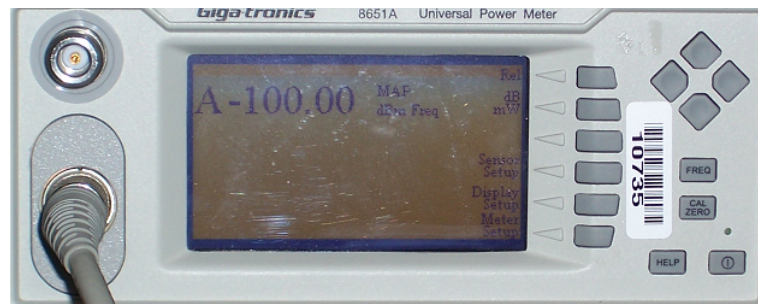

- a. Make sure the meter has been given sufficient time to warm up, if necessary, to enable it to take accurate measurements.
  - b. Zero-calibrate the meter.
  - c. Enable MAP mode.
2. Prepare the DUT using the following AT commands (adjusting the band, channel, bandwidth, modulation, RB allocation, NS, and power level as necessary):
    - a. **ATIINTERCND=<password>** (Unlock extended AT command set.)
    - b. **ATIDAFTMACT** (Enter test mode.)
    - c. **ATIRESET** (Reset the module.)  
(Note: Due to the limited memory footprint on the module's 9x06 chipset, the module must be reset after entering test mode in order to load the FTM memory partition.)
    - d. **ATIINTERCND=<password>** (Unlock extended AT command set.)
    - e. **ATIDAFTMACT** (Enter test mode.)
    - f. **ATIDASBAND=<bandValue>** (Set frequency band (e.g. 34 for LTE B1.)  
• See [Table 12-2](#) on page 113 for appropriate <bandValue> values.
    - g. **ATIDALSTXBW=3** (Set Tx bandwidth to 10 MHz.)
    - h. **ATIDALSRXBW=3** (Set Rx bandwidth to 10 MHz.)
    - i. **ATIDASCHAN=<channel>** (Set modem channel (e.g. 18300 for LTE B1).)  
• See [Table 12-2](#) on page 113 for appropriate <channel> values.
    - j. **ATIDALSTXMOD=0** (Set Tx modulation type to QPSK.)
    - k. **ATIDALSWAVEFORM=1,6,0,0** (Set the Tx waveform characteristics. Make sure to set the correct resource block allocation (2nd parameter) appropriately. For example, 12 is used to produce max power—refer to 3GPP 36.521 table for Maximum Power Reduction (MPR) for Power Class 3 for more information.)
    - l. **ATIDALSNSVAL=1** (Set the LTE NS (Net Sig) value.)
    - m. **ATIDASTXON** (Turn on the transmitter. Note that the transmitter will put out the last power level that was programmed.)
    - n. **ATIDALSTXPWR=1,10** (Begin transmitting at requested power level.)
    - o. Take the measurement.
    - p. Repeat steps n–o with different power levels if desired.
    - q. **ATIDALSTXPWR=0,10** (Reduce Tx power to 0, so next time transmitter is turned on, it will come on with 0 dBm power.)
    - r. **ATIDASTXOFF** (Turn off the transmitter.)

3. Test limits—Run ten or more good DUTs through this test procedure to obtain a nominal output power value.
  - Apply a tolerance of  $\pm 5$  to 6 dB to each measurement (assuming a good setup design).
  - Monitor these limits during mass-production ramp-up to determine if further adjustments are needed.

*Note:*

- The module has a nominal output power of +23 dBm  $\pm 1$  dB in LTE mode. However, the value measured by the power meter is significantly influenced (beyond the stated  $\pm 1$  dB output power tolerance) by the test setup (host RF cabling loss, antenna efficiency and pattern, test antenna efficiency and pattern, and choice of shield box).
- When doing the same test over the air in an RF chamber, values are likely to be significantly lower.

## 12.6 GPRS / EDGE RF Receive Path Test

*Note:* This procedure segment is performed in [Step 14](#) of the [Production Test Procedure](#) on page 109.

**Table 12-3: Test Settings — AirPrime WP7702 GPRS / EDGE Receive Path**

	Band	Band ID	Tx Channel <sup>a</sup>
850 MHz	GSM 850	18	190
900 MHz	E-GSM 900	10	62
1800 MHz	DCS 1800	11	701
1900 MHz	PCS 1900	12	661

a. Channel values shown are at the center of the corresponding bands.

*Note:* This procedure describes steps using the Agilent 8648C signal generator—the Rohde & Schwarz SML03 is shown for reference only.

To test the DUT's receive path:

1. Set up the signal generator:

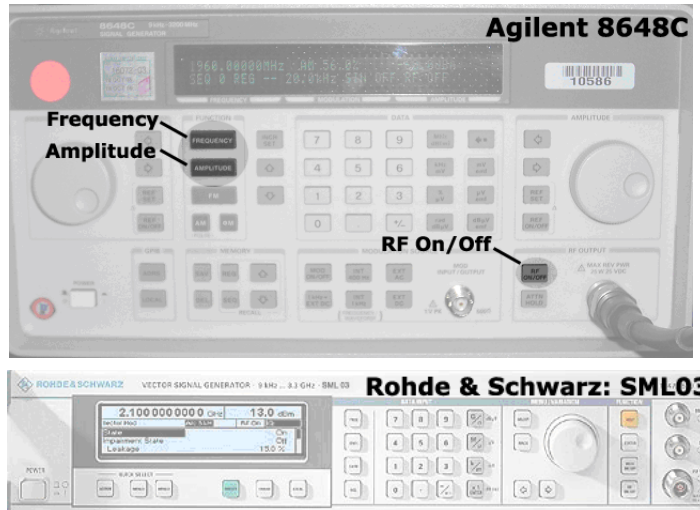

- a. Set the amplitude to:
  - -60 dBm
- b. Set the frequency for the band being tested. See [Table 12-3](#) on page 115 for frequency values.
2. Set up the DUT:
  - a. **ATIINTERCND=<password>** (Unlock extended AT command set.)
  - b. **ATIDAFTMACT** (Put modem into factory test mode.)
  - c. **ATIRESET** (Reset the module.)  
(Note: Due to the limited memory footprint on the module's 9x06 chipset, the module must be reset after entering test mode in order to load the FTM memory partition.)
  - d. **ATIINTERCND=<password>** (Unlock extended AT command set.)
  - e. **ATIDAFTMACT** (Enter test mode.)
  - f. **ATIDASBAND=<band>** (Set frequency band.)
    - See [Table 12-3](#) on page 115 for <band> values
  - g. **ATIDASCHAN=<channel>** (Set modem channel)
    - See [Table 12-3](#) on page 115 for <channel> values
  - h. **ATIDASLNAGAIN=0** (Set the LNA to maximum gain.)
  - i. **ATIDAGSRXBURST=0** (Set to receive bursted mode.)
  - j. **ATIDAGGAVGRSSI=190,0** (For channel 190, for example)  
The returned value is the RSSI in dBm.
3. Test limits — Run ten or more good DUTs through this test procedure to obtain a nominal received power value.
  - Apply a tolerance of  $\pm 5$  to 6 dB to each measurement (assuming a good setup design).
  - Make sure the measurement is made at a high enough level that it is not influenced by DUT-generated and ambient noise.
  - The Signal Generator power level can be adjusted and new limits found if the radiated test needs greater signal strength.
  - Monitor these limits during mass-production ramp-up to determine if further adjustments are needed.

Note: The value measured from the DUT is significantly influenced by the test setup and DUT design (host RF cabling loss, antenna efficiency and pattern, test antenna efficiency and pattern, and choice of shield box).

## 12.7 LTE RF Receive Path Test

Note: This procedure segment is performed in [Step 14](#) of the [Production Test Procedure](#) on page 109.

The suggested test procedure that follows uses the parameters in [Table 12-4](#).

**Table 12-4: Test Settings — WP7702 LTE Receive Path**

Band		Frequency <sup>a</sup> (MHz)	Band ID	Channel <sup>b</sup>
2100 MHz	B1	2142.00	34	18300
1900 MHz	B2	1962.00	43	18900
1800 MHz	B3	1844.50	44	19575
1700 MHz	B4 <sup>c</sup>	2134.50	42	20175
850 MHz	B5	883.50	45	20525
900 MHz	B8	944.50	47	21625
700 MHz	B12	739.50	50	23095
780 MHz	B13	753.00	36	23230
700 MHz	B17 <sup>d</sup>	742.00	37	23790
850 MHz	B18	869.50	54	23925
850 MHz	B19	884.50	55	24075
800 MHz	B20	808.00	56	24300
1900 MHz	B26	878.50	62	26865
700 MHz	B28	782.50	64	27435

- Receive frequencies shown are 2 MHz offset from center
- Channel value used by the !DASCHAN command (!DASCHAN uses uplink (Tx) channel at the center of the corresponding band, for both Tx and Rx testing)
- B4 — CAT-M1 only
- B17 — CAT-NB1 only

Note: This procedure describes steps using the Agilent 8648C signal generator — the Rohde & Schwarz SML03 is shown for reference only.

To test the DUT's receive path:

1. Set up the signal generator:

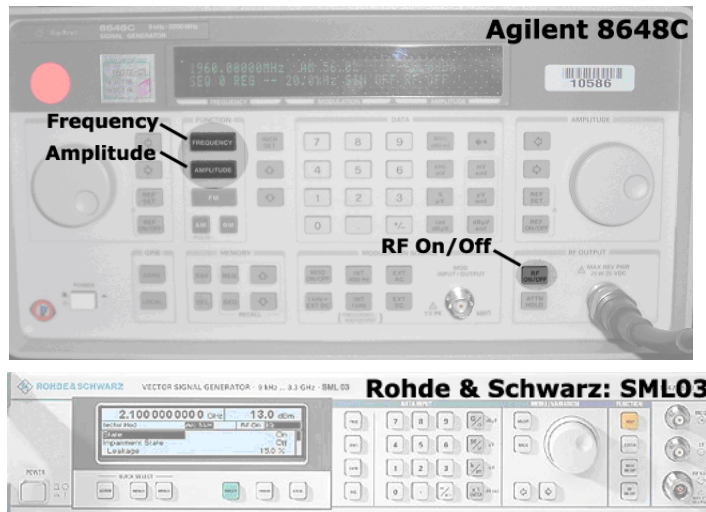

- a. Set the amplitude to -70 dBm.
- b. Set the frequency for the band being tested. See [Table 12-4](#) for frequency values.
2. Set up the DUT:
  - a. **ATIINTERCND=<password>** (Unlock extended AT command set.)
  - b. **ATIDAFTMACT** (Put modem into factory test mode.)
  - c. **ATIRESET** (Reset the module.)  
(Note: Due to the limited memory footprint on the module's 9x06 chipset, the module must be reset after entering test mode in order to load the FTM memory partition.)
  - d. **ATIINTERCND=<password>** (Unlock extended AT command set.)
  - e. **ATIDAFTMACT** (Enter test mode.)
  - f. **ATIDASBAND=<band>** (Set frequency band.)
    - See [Table 12-4](#) for <band> values
  - g. **ATIDALSRXBW=2** (Set Rx LTE bandwidth to 5MHz.)
  - h. **ATIDALSTXBW=2** (Set Tx LTE bandwidth to 5MHz.)
  - i. **ATIDASCHAN=<channel>** (Set modem channel)
    - See [Table 12-4](#) for <channel> values
  - j. **ATIDALGAVGAGC=<channel>,0** (Get averaged Rx AGC)
    - See [Table 12-4](#) for <channel> values
3. Test limits — Run ten or more good DUTs through this test procedure to obtain a nominal received power value.
  - Apply a tolerance of  $\pm 5$  to 6 dB to each measurement (assuming a good setup design).
  - Make sure the measurement is made at a high enough level that it is not influenced by DUT-generated and ambient noise.
  - The Signal Generator power level can be adjusted and new limits found if the radiated test needs greater signal strength.
  - Monitor these limits during mass-production ramp-up to determine if further adjustments are needed.

*Note: The value measured from the DUT is significantly influenced by the test setup and DUT design (host RF cabling loss, antenna efficiency and pattern, test antenna efficiency and pattern, and choice of shield box).*

---

## 12.8 GNSS RF Receive Path Test

The GNSS receive path uses the dedicated GNSS connector.

To test the GNSS receive path:

1. Inject a carrier signal at -110dBm, frequency 1575.52 MHz into the GNSS Rx path at the connector. (Note that this frequency is 100 kHz higher than the actual GPS L1 center frequency.)
2. Test the signal carrier-to-noise level at the GNSS receiver:
  - a. **ATIENTERCND=<password>** (Unlock extended AT command set.)
  - b. **ATIDAFTMACT** (Put modem into factory test mode.)
  - c. **ATIRESET** (Reset the module.)  
(Note: Due to the limited memory footprint on the module's 9x06 chipset, the module must be reset after entering test mode in order to load the FTM memory partition.)
  - d. **ATIENTERCND=<password>** (Unlock extended AT command set.)
  - e. **ATIDAFTMACT** (Enter test mode.)
  - f. **ATIDACGPSTESTMODE=1** (Start CGPS diagnostic task.)
  - g. **ATIDACGPSSTANDALONE=1** (Enter standalone RF mode.)
  - h. **ATIDACGPSMASKON** (Enable log mask.)
  - i. **ATIDACGPSCTON** (Return signal-to-noise and frequency measurements.)
  - j. Repeat **ATIDACGPSCTON** five to ten times to ensure the measurements are repeatable and stable.
3. Leave the RF connection to the embedded module intact, and turn off the signal generator.
4. Take several more **IDACGPSCTON** readings. This will demonstrate a 'bad' signal in order to set limits for testing, if needed. This frequency offset should fall outside of the guidelines in the note below, which indicates that the CtoN result is invalid.
5. (Optional) Turn the signal generator on again, and reduce the level to -120dBm. Take more **IDACGPSCTON** readings and use these as a reference for what a marginal / poor signal would be.

---

*Note: The response to **ATIDACGPSCTON** for a good connection should show CtoN within 58 +/- 5dB and Freq (frequency offset) within 100000 Hz +/- 5000 Hz.*

---

# A: Appendix

For more details, several references can be consulted, as detailed below.

## A.1 Web Site Support

Check <http://source.sierrawireless.com> for the latest documentation available for the AirPrime WP7702.

## A.2 Reference Documents

- [1] AirPrime WPx5/WP76xx/WP77xx AT Command Reference  
Reference number: 4118047
- [2] Inter-Chip USB Supplement to the USB 2.0 Specification Revision 1.0
- [3] Legato.io for Legato API details
- [4] AirPrime WPx5/WP76 Series Customer Process Guidelines  
Reference number: 4116612
- [5] AirPrime WPx5xx/WP76xx/WP77xx Scalability Guide  
Reference number: 41110866
- [6] I2C Bus Specification, Version 2.1, January 2000  
Reference: Phillips Semiconductor document number 9398 393 40011

## A.3 Abbreviations

Table A-1: Acronyms and Terms/Definitions

Acronyms/Terms	Definition
eDRX	Extended Discontinuous Reception
3GPP	3rd Generation Partnership Project
8PSK	Octagonal Phase Shift Keying
ADC	Analog to Digital Converter
AF	Audio-Frequency
API	Application Programming Interface
AT	Attention (prefix for modem commands)
AUI	Application User Interface (AT commands, Legato API library functions, Linux sysfs)
BeiDou	BeiDou Navigation Satellite System A Chinese system that uses a series of satellites in geostationary and middle earth orbits to provide navigational data.
BER	Bit Error Rate — A measure of receive sensitivity
BLER	Block Error Rate
Bluetooth	Wireless protocol for data exchange over short distances
CEP CEP-##	Circular Error Probability — Measure of GPS horizontal accuracy indicating the radius of a circle around the actual position that contains 50% of GPS measurements. CEP-## — Radius of circle containing ##% of GPS measurements (e.g. CEP-90 indicates 90% of measurements contained within circle)
CF3	Common Flexible Form Factor
CLK	Clock
CMOS	Complementary Metal Oxide Semiconductor
CPU	Central Processing Unit
CQI	Channel Quality Indication
CS	Coding Scheme
CTS	Clear To Send
CW	Continuous waveform
DAC	Digital to Analog Converter
dB	Decibel = $10 \times \log_{10} (P1/P2)$ <i>P1 is calculated power; P2 is reference power</i> Decibel = $20 \times \log_{10} (V1/V2)$ <i>V1 is calculated voltage, V2 is reference voltage</i>
dBm	A logarithmic (base 10) measure of relative power (dB for decibels); relative to milliwatts (m). A dBm value will be 30 units (1000 times) larger (less negative) than a dBW value, because of the difference in scale (milliwatts vs. watts).

**Table A-1: Acronyms and Terms/Definitions (Continued)**

Acronyms/Terms	Definition
DC	Direct Current
DCD	Data Carrier Detect
DCS	Digital Cellular System A cellular communication infrastructure that uses the 1.8 GHz radio spectrum.
DL	Downlink (network to mobile)
DRX	Discontinuous Reception
DSR	Data Set Ready
DTR	Data Terminal Ready
E-GSM	Extended GSM
EDGE	Enhance Data rates for GSM Evolution
EFR	Enhanced Full Rate
EGPRS	Enhance GPRS
EIRP	Effective (or Equivalent) Isotropic Radiated Power
EMC	Electromagnetic Compatibility
EN	Enable
ERP	Effective Radiated Power
ESD	Electrostatic Discharges
ETSI	European Telecommunications Standards Institute
FCC	Federal Communications Commission The U.S. federal agency that is responsible for interstate and foreign communications. The FCC regulates commercial and private radio spectrum management, sets rates for communications services, determines standards for equipment, and controls broadcast licensing. Consult <a href="http://www.fcc.gov">www.fcc.gov</a> .
FDD	Frequency Division Duplexing
FDMA	Frequency Division Multiple Access
firmware	Software stored in ROM or EEPROM; essential programs that remain even when the system is turned off. Firmware is easier to change than hardware but more permanent than software stored on disk.
FOV	Field Of View
FR	Full Rate
FSN	Factory Serial Number—A unique serial number assigned to the mini card during manufacturing.
Galileo	A European system that uses a series of satellites in middle earth orbit to provide navigational data.
GCF	Global Certification Forum

Table A-1: Acronyms and Terms/Definitions (Continued)

Acronyms/Terms	Definition
GLONASS	Global Navigation Satellite System— A Russian system that uses a series of 24 satellites in middle circular orbit to provide navigational data.
GMSK	Gaussian Minimum Shift Keying modulation
GND	Ground
GNSS	Global Navigation Satellite Systems (GPS, GLONASS, BeiDou, and Galileo)
GPIO	General Purpose Input Output
GPRS	General Packet Radio Service
GPS	Global Positioning System An American system that uses a series of 24 satellites in middle circular orbit to provide navigational data.
GSM	Global System for Mobile communications
Hi Z	High impedance (Z)
Host	The device into which an embedded module is integrated
HR	Half Rate
HSDPA	High Speed Downlink Packet Access
HSUPA	High Speed Uplink Packet Access
Hz	Hertz = 1 cycle/second
I/O	Input/Output
IC	Industry Canada
IC	Integrated Circuit
IMEI	International Mobile Equipment Identity
IMS	IP Multimedia Subsystem — Architectural framework for delivering IP multimedia services.
inrush current	Peak current drawn when a device is connected or powered on
IOT	Interoperability Testing
IS	Interim Standard. After receiving industry consensus, the TIA forwards the standard to ANSI for approval.
ISIM	IMS Subscriber Identity Module.
LED	Light Emitting Diode. A semiconductor diode that emits visible or infrared light.
LGA	Land Grid Array
LHCP	Left-Hand Circular Polarized
LNA	Low noise Amplifier
LPWA	Low Power Wide Area

**Table A-1: Acronyms and Terms/Definitions (Continued)**

Acronyms/Terms	Definition
LTE	Long Term Evolution—a high-performance air interface for cellular mobile communication systems.
MAX	Maximum
MCS	Modulation and Coding Scheme
MHz	Megahertz = 10e6 Hz
MIC	Microphone
MIMO	Multiple Input Multiple Output—wireless antenna technology that uses multiple antennas at both transmitter and receiver side. This improves performance.
MIN	Minimum
MO	Mobile Originated
MT	Mobile Terminated
N/A	Not Applicable
NMEA	National Marine Electronics Association
NOM	Nominal
OEM	Original Equipment Manufacturer—a company that manufactures a product and sells it to a reseller.
PA	Power Amplifier
packet	A short, fixed-length block of data, including a header, that is transmitted as a unit in a communications network.
PBCCH	Packet Broadcast Control Channel
PC	Personal Computer
PCB	Printed Circuit Board
PCL	Power Control Level
PCS	Personal Communication System A cellular communication infrastructure that uses the 1.9 GHz radio spectrum.
PDN	Packet Data Network
PFM	Power Frequency Modulation
PLL	Phase Lock Loop
PMIC	Power Management Integrated Circuit
PSM	Power Saving Mode
PSS	Primary synchronisation signal
PST	Product Support Tools
PTCRB	PCS Type Certification Review Board

Table A-1: Acronyms and Terms/Definitions (Continued)

Acronyms/Terms	Definition
PWM	Pulse Width Modulation
QAM	Quadrature Amplitude Modulation. This form of modulation uses amplitude, frequency, and phase to transfer data on the carrier wave.
QPSK	Quadrature Phase-Shift Keying
RAM	Random Access Memory
RAT	Radio Access Technology
RF	Radio Frequency
RHCP	Right Hand Circular Polarization
RI	Ring Indicator
RSE	Radiated Spurious Emissions
RSSI	Received Signal Strength Indication
RST	Reset
RTC	Real Time Clock
RTS	Request To Send
RX	Receive
SCLK	Serial Clock
SED	Smart Error Detection
Sensitivity (Audio)	Measure of lowest power signal that the receiver can measure.
Sensitivity (RF)	Measure of lowest power signal at the receiver input that can provide a prescribed BER / BLER / SNR value at the receiver output.
SIM	Subscriber Identity Module.
SKU	Stock Keeping Unit—identifies an inventory item: a unique code, consisting of numbers or letters and numbers, assigned to a product by a retailer for purposes of identification and inventory control.
SMS	Short Message Service
SNR	Signal-to-Noise Ratio
SPI	Serial Peripheral Interface
SPK	Speaker
SW	Software
TAU	Tracking Area Update
TBC	To Be Confirmed
TBD	To Be Determined

**Table A-1: Acronyms and Terms/Definitions (Continued)**

Acronyms/Terms	Definition
TIA/EIA	Telecommunications Industry Association / Electronics Industry Association. A standards setting trade organization, whose members provide communications and information technology products, systems, distribution services and professional services in the United States and around the world. Consult <a href="http://www.tiaonline.org">www.tiaonline.org</a> .
TIS	Total Isotropic Sensitivity
TP	Test Point
TRP	Total Radiated Power
TX	Transmit
TYP	Typical
UART	Universal Asynchronous Receiver-Transmitter
UE	User Equipment
UICC	Universal Integrated Circuit Card
UIM	User Identity Module. Generic term used in this document to refer to UICC, where the application on the UICC (USIM, ISIM, CSIM, etc.) varies depending on the provider of the card.
UL	Uplink (mobile to network)
ULPM	Ultra-Low Power Mode
ULPS	Ultra-Low Power State
UMTS	Universal Mobile Telecommunications System
USB	Universal Serial Bus
USB-SS	USB Selective Suspend / USB not enumerated
USIM	Universal Subscriber Identity Module (UMTS)
USSD	Unstructured Supplementary Services Data
UTRA	UMTS Terrestrial Radio Access
VBAT-BB	Baseband power supply
VBAT-RF	RF power supply
VCC	Supply voltage
VSWR	Voltage Standing Wave Ratio
WCDMA	Wideband Code Division Multiple Access (also referred to as UMTS)
WLAN	Wireless Local Area Network
WWAN	Wireless Wide Area Network
ZIF	Zero Intermediate Frequency