

Author: Sierra Wireless		Date: October 16, 2014					
APN Content Level	BASIC	INTERMEDIATE	<input checked="" type="checkbox"/> ADVANCED	Confidentiality	Public	<input checked="" type="checkbox"/> Private	
Hardware Compatibility	Product Line	AirPrime	Series	HL6528x			
				HiLoV2			
Software Compatibility	ALL						



1 Introduction

The purpose of this document is to give a general overview of the audio system in 2G M2M HL6528x and HiLoV2 modules. It describes the internal audio system blocs.

This document is intended to be used by audio engineers or any person in charge of the audio with sufficient background on audio terms and architecture¹.

As the family modules include both HL6528x and HiLoV2 module platforms, this document addresses the analog audio path on HL6528x and HiLoV2 modules as well as the digital PCM audio on HiLoV2 modules.

2 Front End Audio System

The front end is the termination of the audio system; it includes the analog sub-system on both audio paths.



Analog audio
port location

¹ This document is subject to change without notice.

2.1 Uplink Architecture

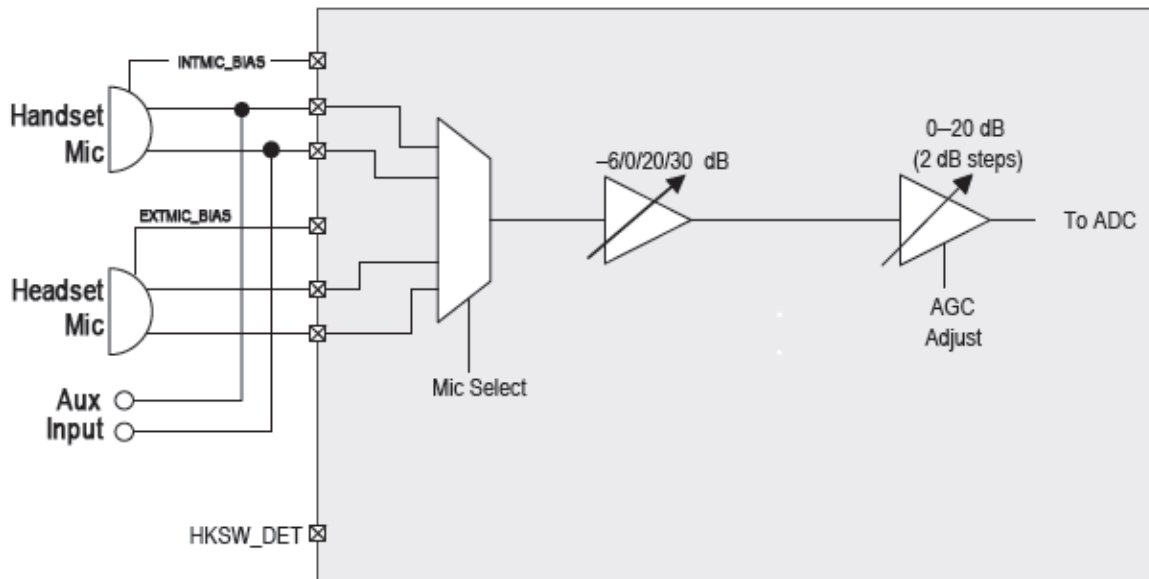

2.2 Downlink Architecture

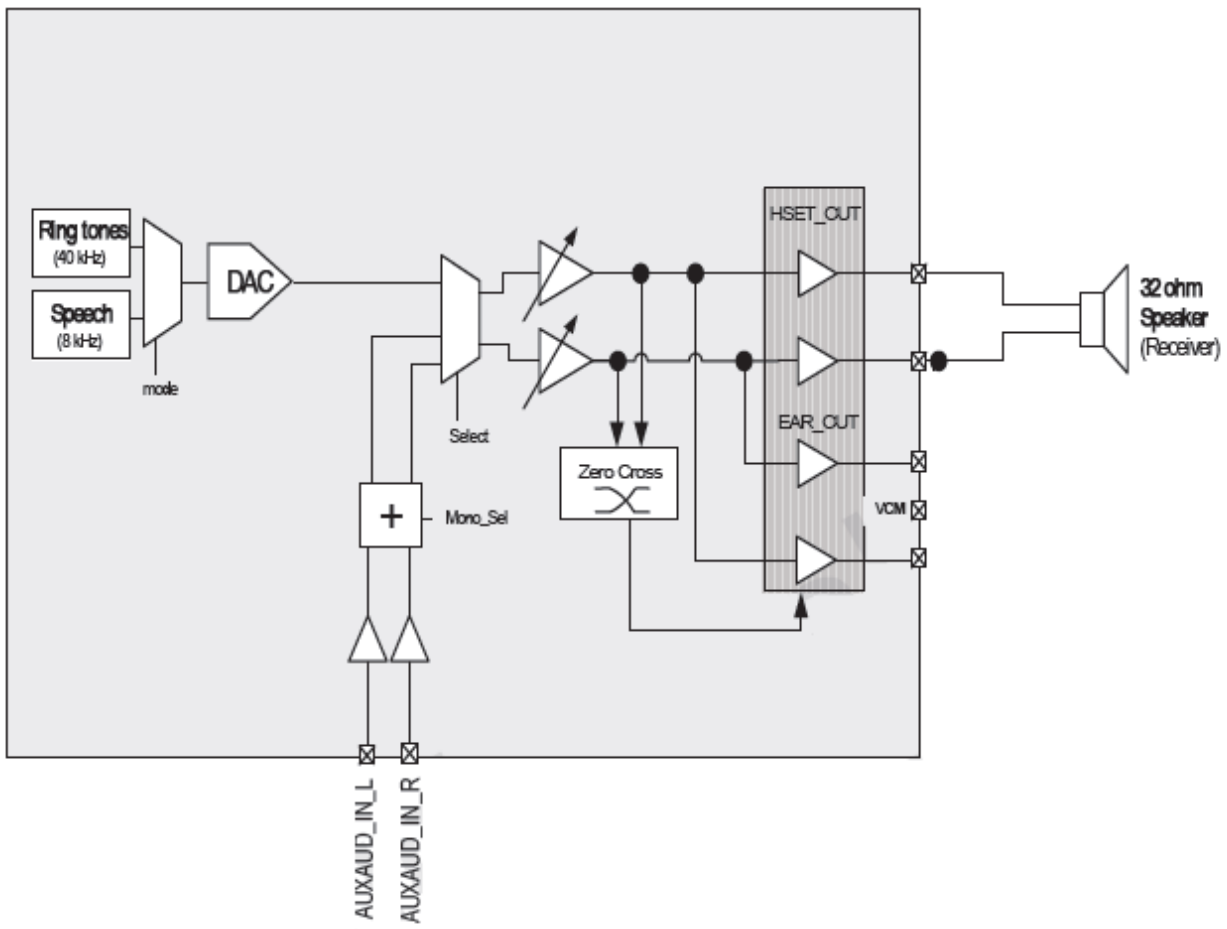

3 DSP Audio System

The DSP portion of the audio link makes the main audio processing and makes the link between the analog sub-system and the GSM speech encoder and decoder units.

3.1 Uplink Portion in Voice Call

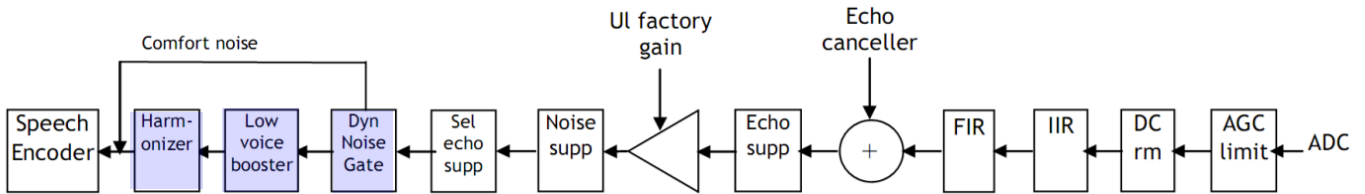

3.2 Downlink Portion in Voice Call

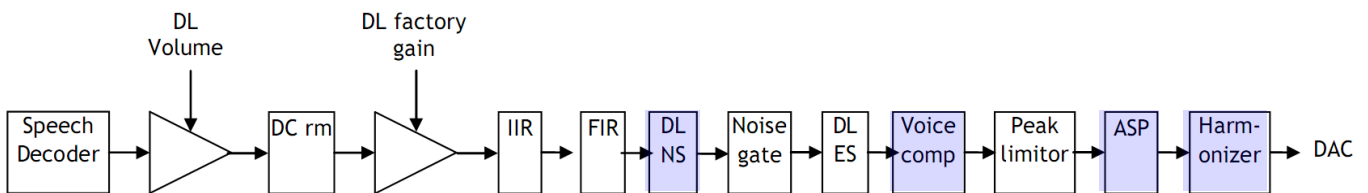

3.3 The Echo Canceller Unit Architecture

The Echo Canceller bloc is a bridge between the uplink and downlink paths.

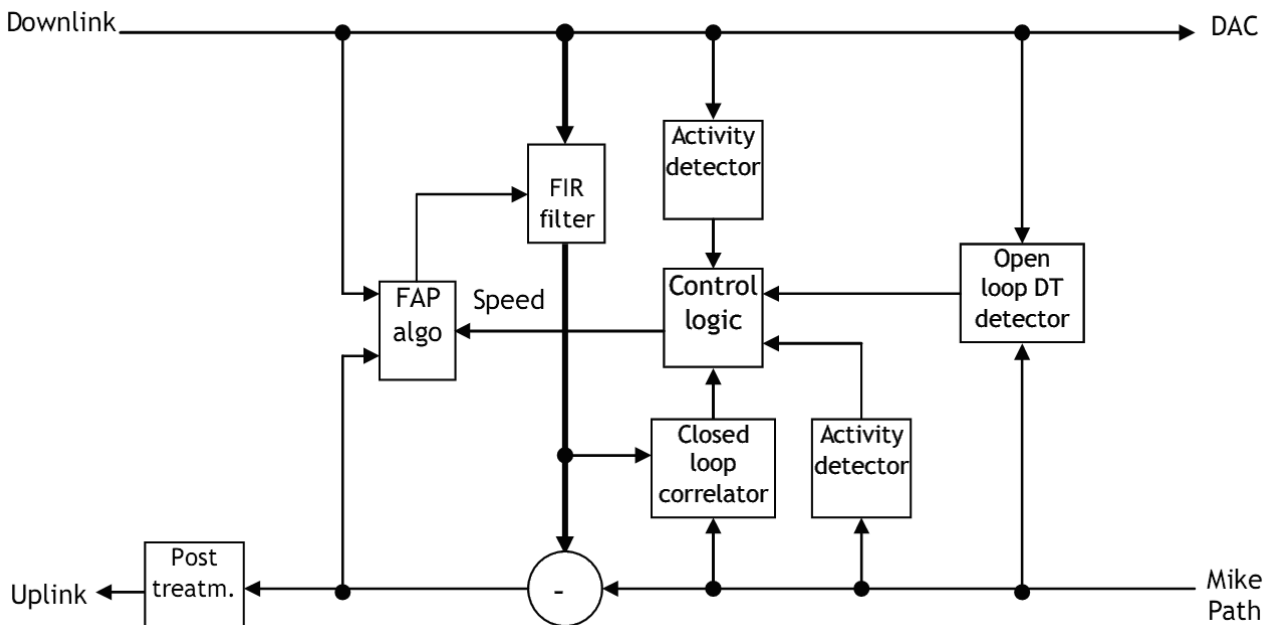

4 AT Commands

A set of AT commands is provided to tune and modify some of the audio units on both uplink and downlink paths. Those commands are described in a dedicated document: **Error! Reference source not found..**

The aim of this section is to add more details about the design limitations and the application domains of the audio AT Commands.

4.1 +VIP Command: Initialize Voice Parameters

This command is used to select a set of audio tuning for uplink and downlink paths for 6 predefined audio modes (Handset, Hands free, Handset raw, Ecall during voice transmission, Ecall during data transmission, PCM Interface).

4.1.1 Application Domains

This command calls a set of data to be applied to the current voice call. Its application domain spreads all over the whole audio architecture units.

4.1.2 Design Limitations

This command calls a set of predefined data. Some of them can be tuned by the other AT commands.

4.2 +VGR Command: Receive Gain Selection

4.2.1 Application Domains

This command fine tunes the DL factory gain unit (of the downlink path). This is typically used to reach a RLR target.

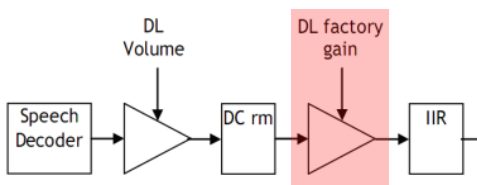

4.2.2 Design Limitations

The command is bounded between -20dB to +18dB to the nominal gain.

4.3 +VGT Command: Transmit Gain Selection

This command modifies the gain in the uplink path. It uses relative gain scale values.

4.3.1 Application Domains

This command fine tunes the UL factory gain unit (of the uplink path). This is typically used to reach a SLR target.

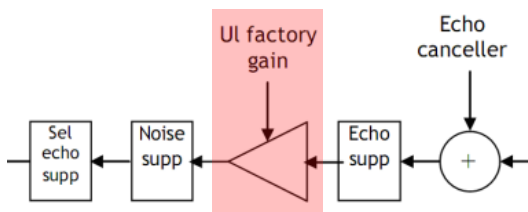

4.3.2 Design Limitations

The command is bounded between -20dB to +18dB to the nominal gain.

4.4 +KVGR Command: Receive Gain Selection

This command modifies the gain in the downlink path. It acts on the same as VGR but it uses absolute gain scale values.

4.4.1 Application Domains

This command fine tunes the DL factory gain unit (of the downlink path). This is typically used to reach a RLR target.

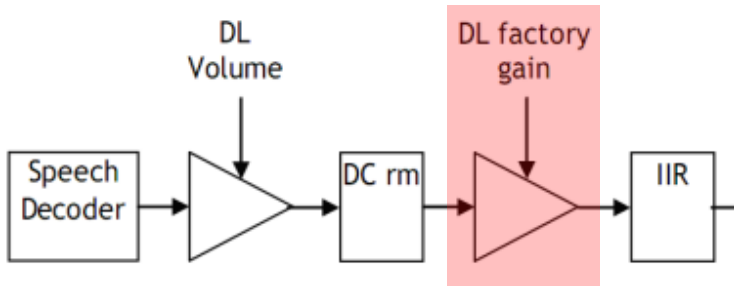

4.4.2 Design Limitations

The command is bounded between -20dB to +18dB to the nominal gain.

4.5 +KVGT Command: Transmit Gain Selection

This command modifies the gain in the uplink path. It acts on the same as VGT but it uses absolute gain scale values.

4.5.1 Application Domains

This command fine tunes the UL factory gain unit (of the uplink path). This is typically used to reach a SLR target.

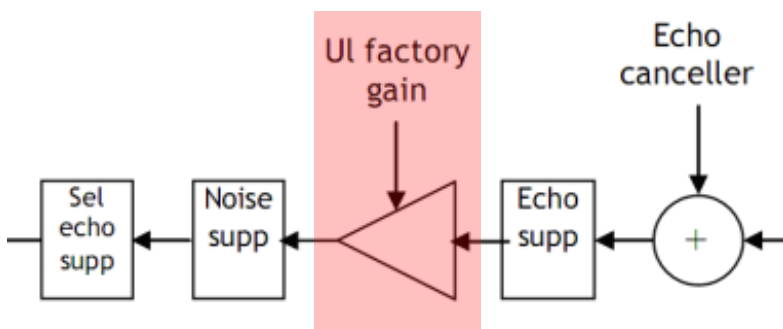

4.5.2 Design Limitations

The command is bounded between -20dB to +18dB to the nominal gain.

4.6 +CLVL Command: Loudspeaker volume level

This command modifies the volume in the downlink path. It uses predefined steps of volumes.

4.6.1 Application Domains

The command tunes the analog audio amplifier by steps of 4 dB with a range of +20dB by steps of 4dB as gain goes from 0 to 9. All gain settings are admissible, but please consider the following:

1. At setting 9, a full scale digital audio signal will be saturated in the analog. Nevertheless, the saturation point is above 90% full scale.
2. For a best signal-to-noise ratio, it is recommended to define the nominal user volume at setting 4 or 5 (for which the RLR is 2dB). Use an external serial resistor with the receiver to adapt the acoustical level. This drives the maximum user volume to setting 7 or 8 (RLR > -13dB).

To maximize the SNR along the UL range of user volumes, consider using the analog gain to control volume instead of the digital gain.

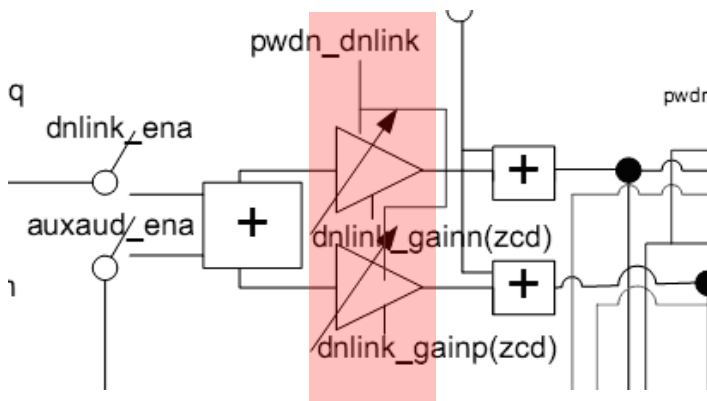

4.6.2 Design Limitations

The step of 4 dB for the volume progress is fixed by design.

4.7 +KECHO Command: Echo Cancellation

This command modifies the echo cancellation and echo suppression units' status on uplink and downlink paths.

4.7.1 Application Domains

The command set the states of the 3 echo processing units on both paths.

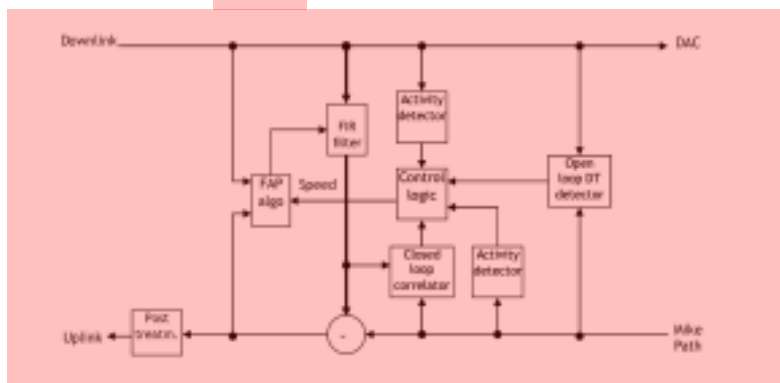
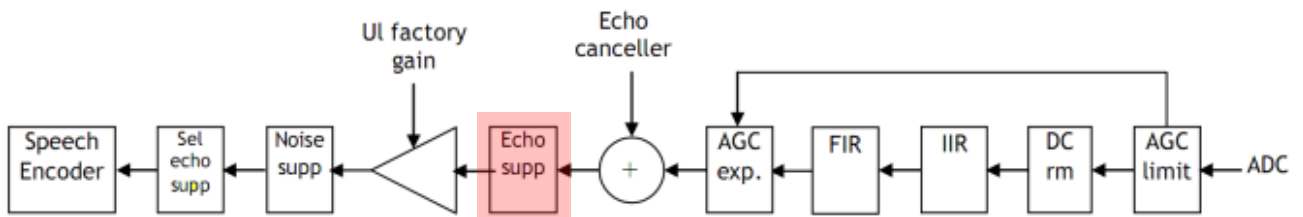

(Figure in section 3.3.)

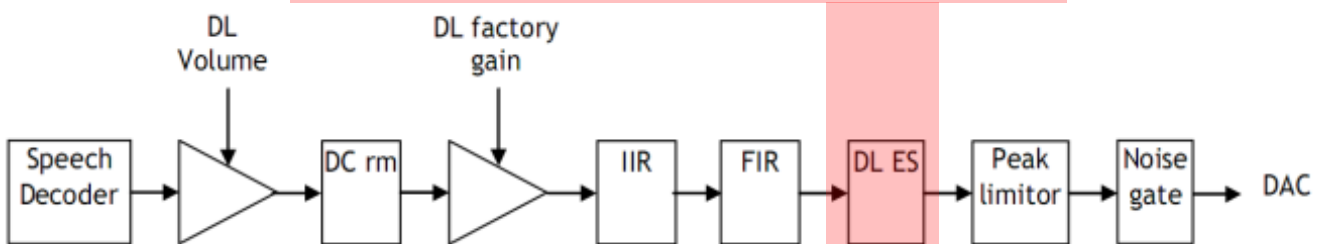

UL echo suppressor its goal is to reduce the mike path gain in case of potential echo, mainly when the downlink path is active. When the downlink path is inactive, the echo suppressor has unity gain.

Echo suppression in the downlink path should only be used if all other echo control functions fail to provide adequate performance. This one is basically used to reduce the downlink path level during double talk operations. Out of double talk operation, the DL echo suppressor has a unity gain

4.7.2 Design Limitations

The command can activate or deactivate the 3 echo processing units and uses a set of predefined levels of suppression and echo cancellation parameters.

4.8 +KNOISE Command: Noise Cancellation

This command modifies the noise suppression units' status on uplink and downlink audio paths.

4.8.1 Application Domains

The command tunes the noise processing units on both audio paths.

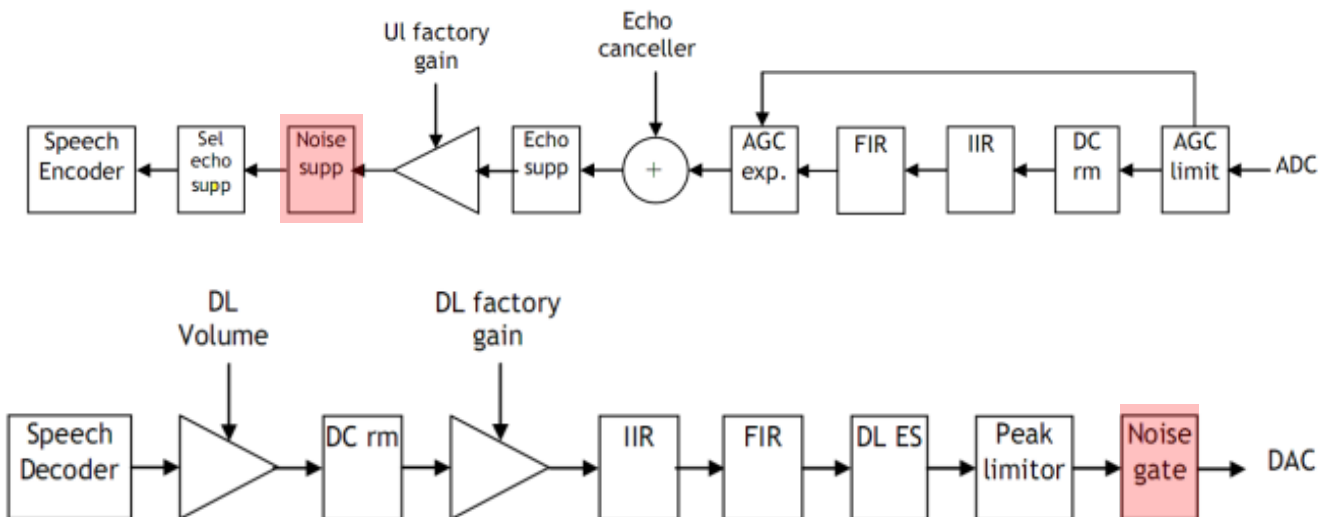

The noise suppressor tracks the stationary levels of the spectrum and tags them as noise. It then subtracts the estimated noise spectrum from the signal spectrum. The noise suppressor module includes a VAD (voice activity detection). When the VAD detects voice, the noise spectrum estimation is inhibited.

The noise gate located on the downlink is an automatic attenuator which helps in removing any residual noise passing in the downlink path (network noise floor, noise suppressor tonal noise residue ...). Thus, below the active signal threshold, the noise gate inserts attenuation and thus, the residual noise could be attenuated or even totally cancelled

4.8.2 Design Limitations

The command can activate or deactivate the 2 noise processing units and uses a set of predefined levels of noise detection and attenuation parameters.

4.9 +KST Command: Side Tone

This command modifies the side tone unit status and set a gain between both audio paths.

4.9.1 Application Domains

The command tunes the gain of the analog side tone to get the desired STMR value between the uplink and downlink paths.

The side tone loop path can be enabled or disabled.

The side tone gain can be adjusted from -26dB to +6dB by step of 2dB. Then the side tone gain setting goes from 0 to 16.

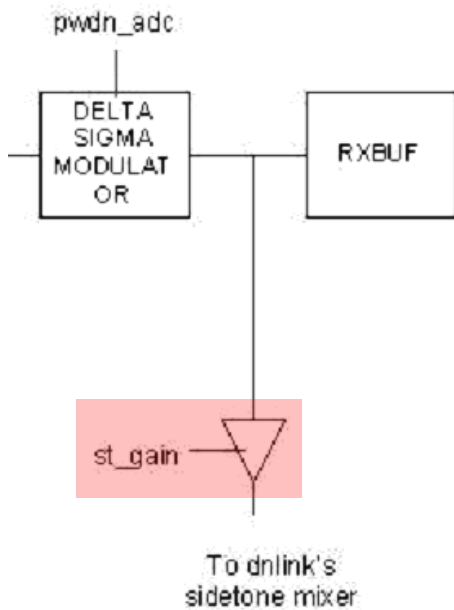

The side tone acoustical gain should remain fixed basically for the end user, whatever the downlink volume he is using. The software calculates for each new user volume the corresponding side tone setting to apply in order to keep constant the acoustic sidetone gain.

4.9.2 Design Limitations

The value coding the sidetone setting is applied when the user volume setting is CLVL 5.

4.10 +KPC Command: Peak Compressor

This command modifies the peak compressor (also referred as Peak Limiter) units' status.

4.10.1 Application Domains

This command modifies the peak compressor units' status and applies the predefined set parameters.

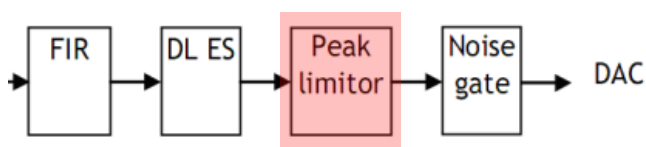

The peak limiter is used to reduce the peak factor of the audio signal. This helps getting more RMS level while keeping the peaks of signal below the clipping point of the audio path. This feature is useful in loud volume operation.

4.10.2 Design Limitations

The command can activate or deactivate the peak compressor unit and uses a set of predefined levels of noise detection and attenuation parameters.

4.11 +KSRAP Command: Save Restore Audio Parameters

This command is used to save or restore the audio parameters.

4.11.1 Application Domains

This command saves in flash internal memory the changes done on the audio tuning parameters and is also able to recall the initial factory audio settings.

4.11.2 Design Limitations

The audio tuning parameters can be saved in a single databank.

5 PCM

This chapter addresses the case of the digital audio on PCM bus. The PCM specifications are presented and the dedicated AT commands set are described in the document: **Error! Reference source not found..**

5.1 Specifications

The PCM port available on HL6528x and HiLoV2 M2M modules shares the sample buffers with the internal DAC and ADC. Hence, it is not possible to run simultaneously the PCM and the internal codec at the same time. When PCM port is not enabled by the AT command, the DAC or ADC is by default selected.

The PCM port can be configured independently as master or slave operation for bit clock and word synchronization.

In master mode the bit clock is limited to 1MHz (1000Hz). In slave mode, the bit clock can go up to 1.625MHz.

The clock polarity is programmable.

The PCM port supports 8 and 16 bit data words with programmable bit order (MSB first or LSB first).

The DSP can only source and sink data at 8kS/s. The DSP includes a mechanism to adapt the sample rate if the PCM rate differs slightly. Nevertheless, this mechanism cannot be considered as a sample rate converter so the word synchronization frequency should remain close to 8 kHz. The Linear-Law is always used; A-Law and μ -Law are not managed.

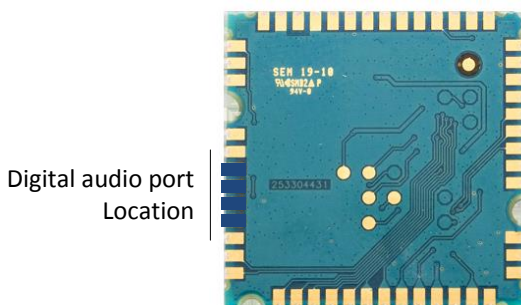

5.2 Timing

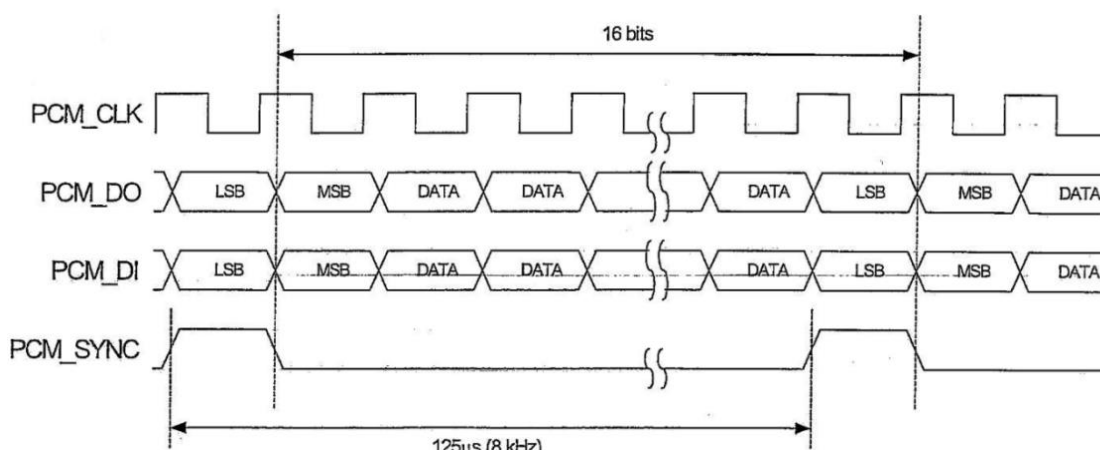

5.3 PCM vs. Analog

Analog audio communication is suitable and sufficient when the floor noise is weak.

In reality it is rare and often the audio systems include amplifier to transport the signal on a long distance, in a noisy environment or even both, in those cases the digital audio helps to get a significant improvement in the results.

The audio signal is sampled at the source and reconstructed at the end point avoiding the effect of the noise during the transmission.

5.4 Use Cases

The PCM can be used to connect the HL6528x and HiLoV2 family modules to either an external processor which may process the digital audio or simply use a chip codec like MAXIM® MAX98XX family to convert the digital audio into an analog.

6 Reference Documents

27.007 3GPP 27.007 (6.0.0) - AT command Set for User Equipment (UE) (Release 6).

URD1 OTL 5635.1 008 AT command Set for SAGEM HILO Module.

URD1 OTL 5665.3 003 72238 HiLoNC V2 Application Note 11 March 2011.pdf

URD1 OTL 5665.3 001 71927 HiLoNC V2 technical specification rev dpt.doc

URD1 OTL 5635.2 013 72398 HiLo V2 technical specification rev dpt.doc

URD1 OTL 5635.2 007 72335 HiLo V2 application note 15 March 2011.pdf

URD1 OTL 5635.1 005 70086 HiLo technical specification base urd.doc

URD1 OTL 5665.1 001 70883 HiLoNC technical specification.doc

URD1 OTL 5665.1 002 70884 HiLoNC application note.doc

URD1 OTL 5635.1 007 70230 HiLo application note.pdf

AirPrime - HL6 and HL8 Series - AT Commands Interface Guide, Reference 4114680

7 Support

For direct clients: contact your Sierra Wireless FAE

For distributor clients: contact your distributor FAE

For distributors: contact your Sierra Wireless FAE

8 Document History

Level	Date	History
1.0	October 14, 2014	Creation

9 Legal Notice

Important Notice

Due to the nature of wireless communications, transmission and reception of data can never be guaranteed. Data may be delayed, corrupted (i.e., have errors) or be totally lost. Although significant delays or losses of data are rare when wireless devices such as the Sierra Wireless modem are used in a normal manner with a well-constructed network, the Sierra Wireless modem should not be used in situations where failure to transmit or receive data could result in damage of any kind to the user or any other party, including but not limited to personal injury, death, or loss of property. Sierra Wireless accepts no responsibility for damages of any kind resulting from delays or errors in data transmitted or received using the Sierra Wireless modem, or for failure of the Sierra Wireless modem to transmit or receive such data.

Safety and Hazards

Do not operate the Sierra Wireless modem in areas where cellular modems are not advised without proper device certifications. These areas include environments where cellular radio can interfere such as explosive atmospheres, medical equipment, or any other equipment which may be susceptible to any form of radio interference. The Sierra Wireless modem can transmit signals that could interfere with this equipment. Do not operate the Sierra Wireless modem in any aircraft, whether the aircraft is on the ground or in flight. In aircraft, the Sierra Wireless modem **MUST BE POWERED OFF**. When operating, the Sierra Wireless modem can transmit signals that could interfere with various onboard systems.

Note: Some airlines may permit the use of cellular phones while the aircraft is on the ground and the door is open. Sierra Wireless modems may be used at this time.

The driver or operator of any vehicle should not operate the Sierra Wireless modem while in control of a vehicle. Doing so will detract from the driver or operator's control and operation of that vehicle. In some states and provinces, operating such communications devices while in control of a vehicle is an offence.

Limitations of Liability

This manual is provided "as is". Sierra Wireless makes no warranties of any kind, either expressed or implied, including any implied warranties of merchantability, fitness for a particular purpose, or noninfringement. The recipient of the manual shall endorse all risks arising from its use.

The information in this manual is subject to change without notice and does not represent a commitment on the part of Sierra Wireless. SIERRA WIRELESS AND ITS AFFILIATES SPECIFICALLY DISCLAIM LIABILITY FOR ANY AND ALL DIRECT, INDIRECT, SPECIAL, GENERAL, INCIDENTAL, CONSEQUENTIAL, PUNITIVE OR EXEMPLARY DAMAGES INCLUDING, BUT NOT LIMITED TO, LOSS OF PROFITS OR REVENUE OR ANTICIPATED PROFITS OR REVENUE ARISING OUT OF THE USE OR INABILITY TO USE ANY SIERRA WIRELESS PRODUCT, EVEN IF SIERRA WIRELESS AND/OR ITS AFFILIATES HAS BEEN ADVISED OF THE POSSIBILITY OF SUCH DAMAGES OR THEY ARE FORESEEABLE OR FOR CLAIMS BY ANY THIRD PARTY.

Notwithstanding the foregoing, in no event shall Sierra Wireless and/or its affiliates aggregate liability arising under or in connection with the Sierra Wireless product, regardless of the number of events, occurrences, or claims giving rise to liability, be in excess of the price paid by the purchaser for the Sierra Wireless product.

Customer understands that Sierra Wireless is not providing cellular or GPS (including A-GPS) services. These services are provided by a third party and should be purchased directly by the Customer.

SPECIFIC DISCLAIMERS OF LIABILITY: CUSTOMER RECOGNIZES AND ACKNOWLEDGES SIERRA WIRELESS IS NOT RESPONSIBLE FOR AND SHALL NOT BE HELD LIABLE FOR ANY DEFECT OR DEFICIENCY OF ANY KIND OF CELLULAR OR GPS (INCLUDING A-GPS) SERVICES.

Patents

This product may contain technology developed by or for Sierra Wireless Inc.

This product includes technology licensed from QUALCOMM®.

This product is manufactured or sold by Sierra Wireless Inc. or its affiliates under one or more patents licensed from InterDigital Group and MMP Portfolio Licensing.

Copyright

© 2014 Sierra Wireless. All rights reserved.

Trademarks

Sierra Wireless®, AirPrime®, AirLink®, AirVantage®, WISMO® and the Sierra Wireless and Open AT logos are registered trademarks of Sierra Wireless, Inc. or one of its subsidiaries.

Watcher® is a registered trademark of Netgear, Inc., used under license.

Windows® and Windows Vista® are registered trademarks of Microsoft Corporation.

Macintosh® and Mac OS X® are registered trademarks of Apple Inc., registered in the U.S. and other countries.

QUALCOMM® is a registered trademark of QUALCOMM Incorporated. Used under license.

Other trademarks are the property of their respective owners.