



AirPrime BC118

Product Technical Specification



SIERRA
WIRELESS®

41110676
Rev 2

Important Notice

Due to the nature of wireless communications, transmission and reception of data can never be guaranteed. Data may be delayed, corrupted (i.e., have errors) or be totally lost. Although significant delays or losses of data are rare when wireless devices such as the Sierra Wireless modem are used in a normal manner with a well-constructed network, the Sierra Wireless modem should not be used in situations where failure to transmit or receive data could result in damage of any kind to the user or any other party, including but not limited to personal injury, death, or loss of property. Sierra Wireless accepts no responsibility for damages of any kind resulting from delays or errors in data transmitted or received using the Sierra Wireless modem, or for failure of the Sierra Wireless modem to transmit or receive such data.

Safety and Hazards

Do not operate the Sierra Wireless modem in areas where blasting is in progress, where explosive atmospheres may be present, near medical equipment, near life support equipment, or any equipment which may be susceptible to any form of radio interference. In such areas, the Sierra Wireless modem **MUST BE POWERED OFF**. The Sierra Wireless modem can transmit signals that could interfere with this equipment.

Do not operate the Sierra Wireless modem in any aircraft, whether the aircraft is on the ground or in flight. In aircraft, the Sierra Wireless modem **MUST BE POWERED OFF**. When operating, the Sierra Wireless modem can transmit signals that could interfere with various onboard systems.

Note: Some airlines may permit the use of cellular phones while the aircraft is on the ground and the door is open. Sierra Wireless modems may be used at this time.

The driver or operator of any vehicle should not operate the Sierra Wireless modem while in control of a vehicle. Doing so will detract from the driver or operator's control and operation of that vehicle. In some states and provinces, operating such communications devices while in control of a vehicle is an offence.

Limitation of Liability

The information in this manual is subject to change without notice and does not represent a commitment on the part of Sierra Wireless. SIERRA WIRELESS AND ITS AFFILIATES SPECIFICALLY DISCLAIM LIABILITY FOR ANY AND ALL DIRECT, INDIRECT, SPECIAL, GENERAL, INCIDENTAL, CONSEQUENTIAL, PUNITIVE OR EXEMPLARY DAMAGES INCLUDING, BUT NOT LIMITED TO, LOSS OF PROFITS OR REVENUE OR ANTICIPATED PROFITS OR REVENUE ARISING OUT OF THE USE OR INABILITY TO USE ANY SIERRA WIRELESS PRODUCT, EVEN IF SIERRA WIRELESS AND/OR ITS AFFILIATES HAS BEEN ADVISED OF THE POSSIBILITY OF SUCH DAMAGES OR THEY ARE FORESEEABLE OR FOR CLAIMS BY ANY THIRD PARTY.

Notwithstanding the foregoing, in no event shall Sierra Wireless and/or its affiliates aggregate liability arising under or in connection with the Sierra Wireless product, regardless of the number of events, occurrences, or claims giving rise to liability, be in excess of the price paid by the purchaser for the Sierra Wireless product.

Patents

This product may contain technology developed by or for Sierra Wireless Inc. This product includes technology licensed from QUALCOMM®. This product is manufactured or sold by Sierra Wireless Inc. or its affiliates under one or more patents licensed from InterDigital Group and MMP Portfolio Licensing.

Copyright

© 2018 Sierra Wireless. All rights reserved.

Trademarks

Sierra Wireless®, AirPrime®, AirLink®, AirVantage® and the Sierra Wireless logo are registered trademarks of Sierra Wireless, Inc.

Windows® and Windows Vista® are registered trademarks of Microsoft Corporation.

QUALCOMM® is a registered trademark of QUALCOMM Incorporated. Used under license.

Other trademarks are the property of their respective owners.

Contact Information

Sales information and technical support, including warranty and returns	Web: sierrawireless.com/company/contact-us/ Global toll-free number: 1-877-687-7795 6:00 am to 5:00 pm PST
Corporate and product information	Web: sierrawireless.com

Revision History

Revision number	Release date	Changes
1	March 27, 2017	Initial conversion to SWI template.
2	August 2018	Updated PIO_8 description

>> Contents

Introduction	5
Applications	6
Key Specifications	6
General Specifications	6
RF Specifications	6
Electric Specifications	7
Power Measurements with Melody	8
Physical Characteristics	9
Module Drawing	9
Module Footprint	10
Placement Considerations	11
PIN Descriptions	11
Notes	13
Hardware Design Guidelines	14
BC118 with Battery and Host	14
BC118 with Fixed Supply and Host	14
BC118 with Battery and No Host	15
BC118 with Fixed Supply and No Host	15
Notes	15
Solder Reflow Profile	16
Regulatory Certifications	17
United States	17
Canada	18
Bluetooth Qualification Program (BQP)	18

>> 1: Introduction

BC118 is a highly flexible, ultra low power, small form factor Bluetooth Version 4.1 Certified module. It comes preloaded with Sierra Wireless Melody Smart software, and is ideal for developers who want to quickly and cost effectively integrate Bluetooth Low Energy functionality into their products or develop standalone sensors or accessories.



Figure 1-1: BC118

Note: This is an example image and does not represent the label used on commercial shipments.

BC118

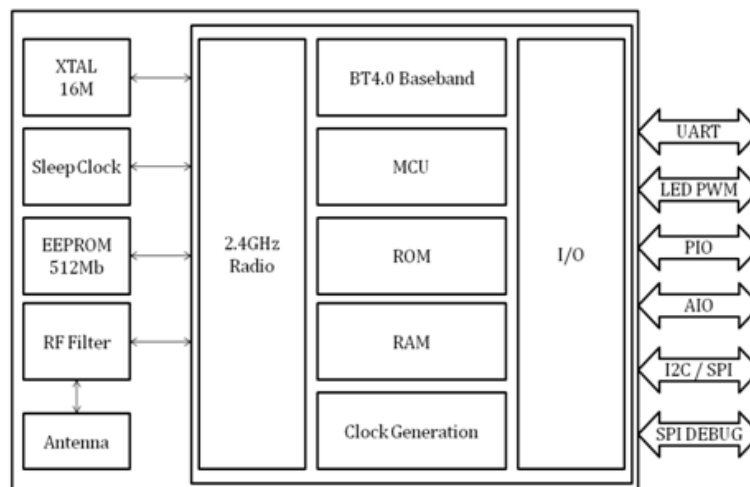

Figure 1-2: BC118 Flow Diagram

Applications

- Industrial Automation
- Lighting
- Automotive
- Medical Devices
- Wearable Devices
- Sensors, Actuators

Key Specifications

- Bluetooth Certified 4.1 Audio module
- Single Mode: Bluetooth Low Energy (BLE)
- Embedded Bluetooth Protocol Stack
- Supports GATT Profile, Audio, Proximity, and iBeacon
- Supports I2C and UART transparent Data Modes
- Simple UART, GPIO, APP interface for command and control
- Small form factor (19.3mm x 14.4mm x 2.8mm)

General Specifications

Table 1-1: General Specifications

Specification	Description
Bluetooth Standard	Bluetooth 4.1
Interfaces	UART, AIO, GPIO, USB, I2C
Size	19.3mm x 14.4mm x 2.8mm
Weight	0.9g

RF Specifications

Table 1-2: RF Specifications

Specification	Description
Frequency Band	2,402 MHz to 2,480 MHz
Modulation	8 DPSK, PI/4 DQPSK, GFSK
Maximum Data Rate	270kbps (typical 60kbps)
Operating Range	Up to 50m
RF Sensitivity	0.1% BER at -92.5dBm
Transmit Power	7.5dBm

Electric Specifications

Table 1-3: Electrical Specifications

Specification	Description
Supply Voltage	1.8V to 3.6V DC (Supports Lithium battery voltage range) ^a
Typical Current Tx	16mA (Only on Tx/Rx)
Typical Deep Sleep	<8 μ A (Connected)
Typical Hibernate	<1.9 μ A (Not Connected)
Typical Dormant	<900nA
Operating Temperature	-40°C to 85°C
Storage Temperature	-40°C to 105°C

a. For using SLEEP MODE (for low power consumption), the maximum voltage is 3.8V.

2: Power Measurements with Melody

Table 2-1 describes BC118 module power measurements made under the following conditions:

- Melody Smart configuration:
 - SLEEP=ON
 - TRSE=ON
 - TRSM=1
 - WAKE=OFF
- For additional details, refer to Melody Smart User Guide (Doc #41110706).
- UART disconnected to remove leakage, and RX pin pulled high via a 5k6 resistor (resistor leakage current included in current measurement values).
- For Send/Receive tests, wired loopback used on UART interface connecting TX to RX pins on device measured.
- Measurements performed using analogue integration across a 1Ω 1% resistor measured with an Agilent 5½ digit Digital Multimeter at 100 mA precision.

Table 2-1: Reference Power Measurements

Set Up	Idle [mA]	Fast Advertising ^a [mA]	Slow Advertising [mA]	Scanning ^b [mA]	Connected Idle ^c [mA]	Connected Send+Recv ^d [mA]
Melody Smart Default^e	0.008	0.478	0.043	4.650	0.430	0.5.00 ^f
Lowest Power^g	0.008	NA	0.032	0.100	0.010	0.045 ^h

- a. Applicable to Melody Smart in Peripheral mode only.
- b. Applicable to Melody Smart in Central mode only.
- c. Tested with Slave latency equal to zero. Peripheral consumption can be lower with a larger a slave latency.
- d. Applicable to Melody Smart in Central mode only.
- e. Measurements done using the default Melody Smart Advertisement, Connection and Scan parameters;
- f. Send and receive of one 20 byte packet/s at 9600 baud UART.
- g. Measurements done using Melody Smart configured to: ADVP=2800 2800, SCNP=009C400 000009C4, CONP=0C80 0C80 0006 0C80.
- h. Send and receive of one 20 byte packet/connection interval at 9600 baud UART.

>> 3: Physical Characteristics

Module Drawing

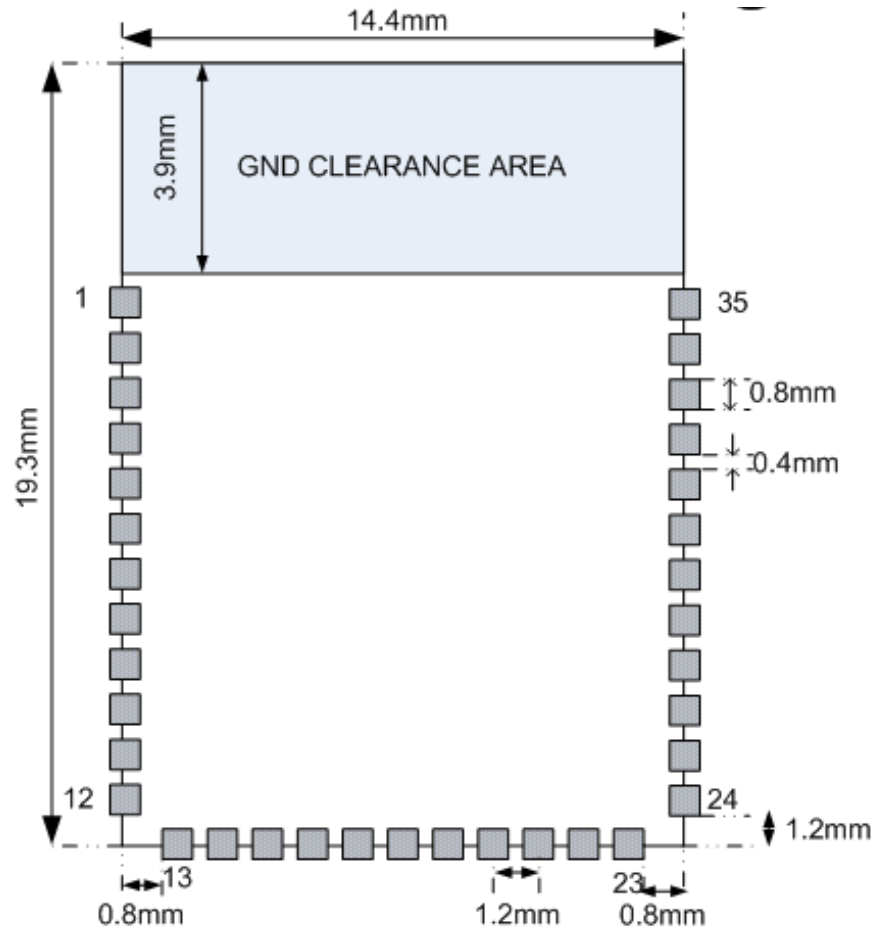

Figure 3-1: Module Drawing (Top view)

Placement Considerations

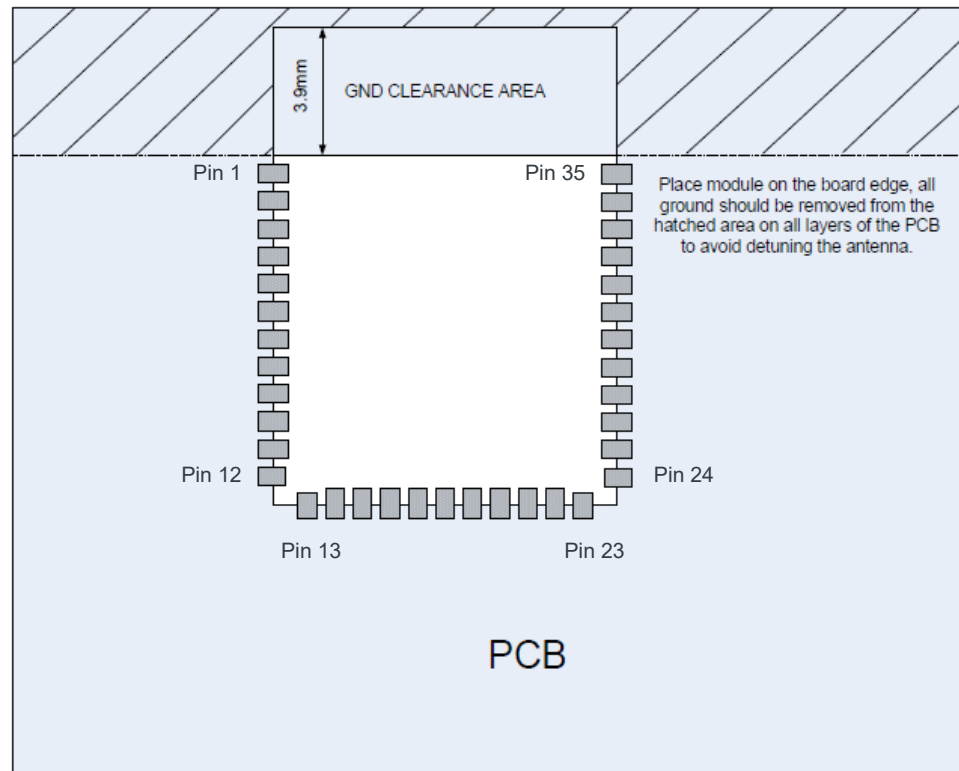

Figure 3-3: Placement Considerations

PIN DESCRIPTIONS

Note: As shown in [Figure 3-3](#), pin 1 is located at the top left of the module, with remaining pins numbered counter-clockwise from pin 1.

Table 3-1: Pin Descriptions

Pin #	Pin Name	Pin Type	Pin Description
1	GND	GND	Common Ground
2	GND	GND	Common Ground
3	AIO_2	Bi-Directional	Analog programmable input/output line
4	AIO_1	Bi-Directional	Analog programmable input/output line
5	AIO_0	Bi-Directional	Analog programmable input/output line
6	UART_TX	Bi-Directional	UART TX Data
7	UART_RX	Bi-Directional	UART TX Data

Table 3-1: Pin Descriptions

Pin #	Pin Name	Pin Type	Pin Description
8	PIO_3	Bi-Directional	Programmable input/output line
9	PIO_4	Bi-Directional	Programmable input/output line
10	PIO_5/ SPI_CLK	Bi-Directional	Programmable input/output line
11	PIO_6/ SPI_CSB	Bi-Directional	Programmable input/output line
12	GND	GND	Common Ground
13	GND	GND	Common Ground
14	PIO_7/ SPI_MOSI	Bi-Directional	Programmable input/output line
15	GND	GND	Common Ground
16	GND	GND	Common Ground
17	VDD_PADS	Supply	Positive Supply Input
18	GND	GND	Common Ground
19	PIO_8/ SPI_MISO	Bi-Directional	<p>Programmable input/output line</p> <p>Module control functions include:</p> <ul style="list-style-type: none"> Exit BLE transparent data mode—If GPIO control is enabled and the module has been placed in BLE transparent data mode (via a software command), use PIO_8 to exit data mode. Pull PIO_8 high via an external control (e.g. SW1 on BC118 Discovery Board) and then release. Factory restore the module to default configuration settings—Hold PIO_8 high at boot until the welcome prompt appears. Exit beacon mode—Pull PIO_8 high. <p>For details, refer to the Melody Smart User Guide (Doc #41110706), available at source.sierrawireless.com.</p> <p><i>Note: The customer design should expose and control PIO_8 in their application.</i></p>
20	SPI_PIO#	Input	Select SPI/PIO
21	PIO_2	Bi-Directional	Programmable input/output line
22	I2C_SCL	Bi-Directional	Programmable input/output line
23	GND	GND	Common Ground
24	GND	GND	Common Ground
25	I2C_SDA	Bi-Directional	Programmable input/output line
26	PIO_9	Bi-Directional	Programmable input/output line
27	VBAT	Battery terminal +ve	Battery Positive
28	PIO_10	Bi-Directional	Programmable input/output line

Table 3-1: Pin Descriptions

Pin #	Pin Name	Pin Type	Pin Description
29	PIO_11	Bi-Directional	Programmable input/output line
30	WAKE	Wake Pin	Wake Pin
31	GND	GND	Common Ground
32	GND	GND	Common Ground
33	GND	GND	Common Ground
34	GND	GND	Common Ground
35	GND	GND	Common Ground

Notes

- PIO_X are bidirectional with weak pull down
- Reset Input is with strong pull-up
- UART are Bidirectional with weak pull up

4: Hardware Design Guidelines

BC118 with Battery and Host

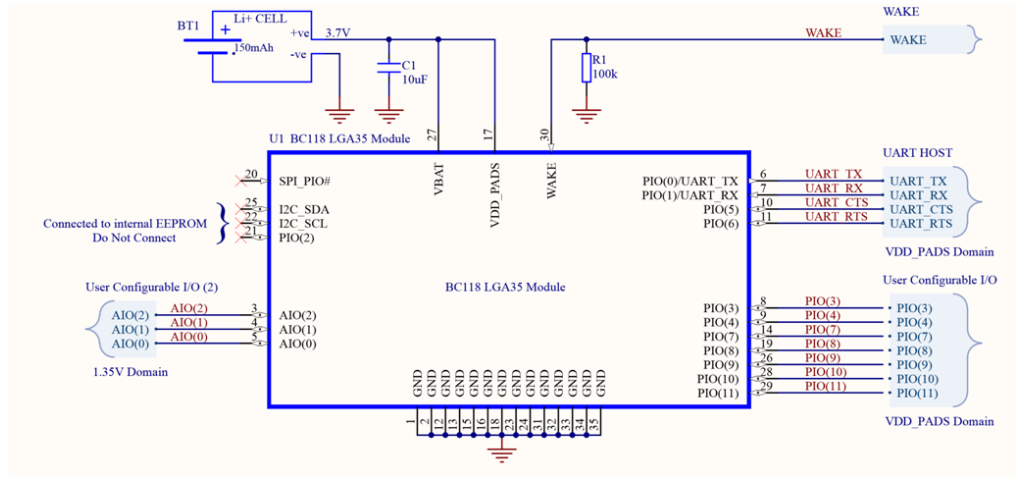

Figure 4-1: Hardware Design with Battery and Host

BC118 with Fixed Supply and Host

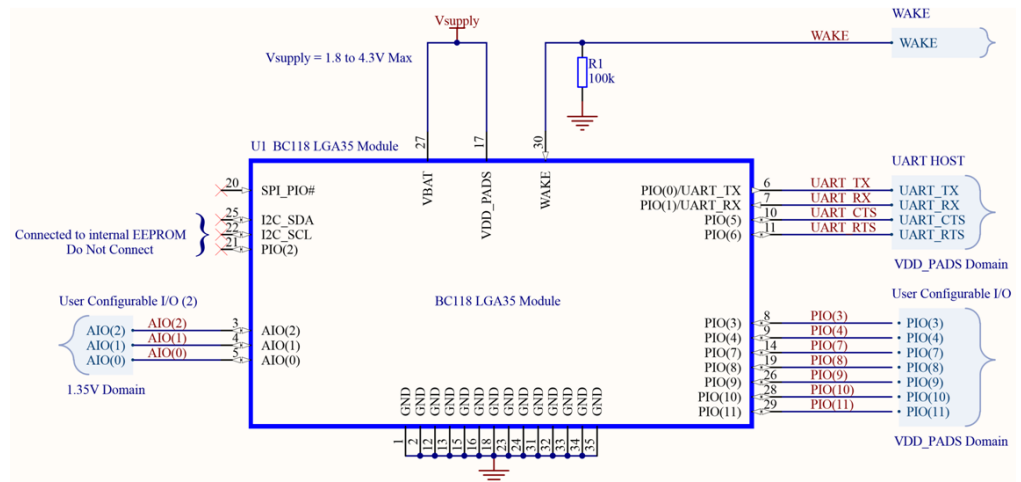

Figure 4-2: Hardware Design with Fixed Supply and Host

BC118 with Battery and No Host

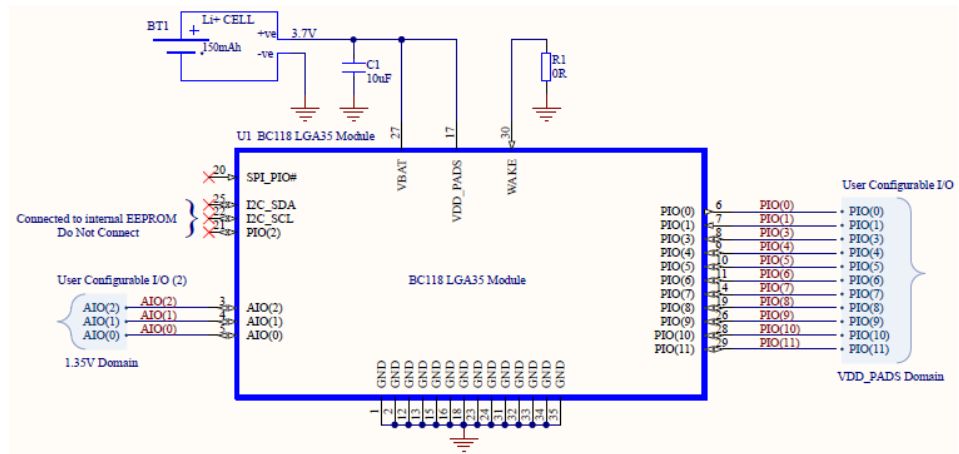

Figure 4-3: Hardware Design with Battery and No Host

BC118 with Fixed Supply and No Host

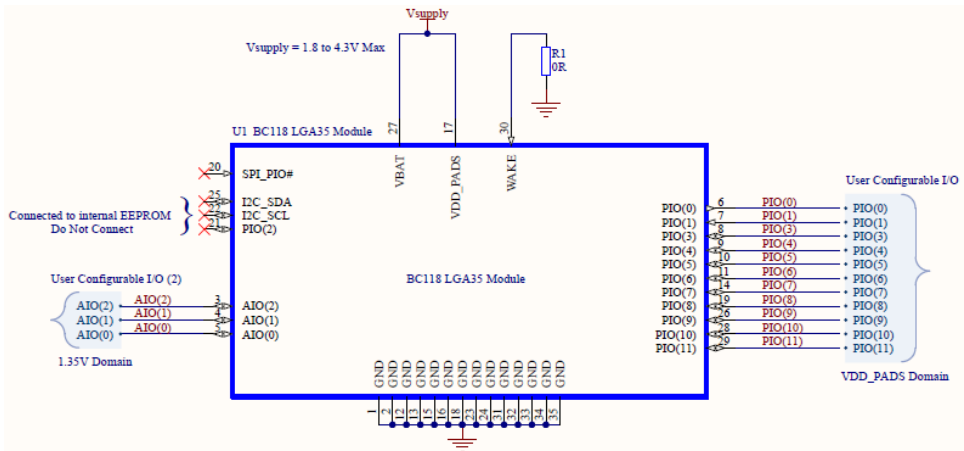

Figure 4-4: Hardware Design with Fixed Supply and No Host

Notes

- The voltage applied to VBAT should meet a maximum rise time (VBAT = 0V to VBAT = 1.8V) of 5ms under all circumstances.

>> 5: Solder Reflow Profile

The solder profile is described below.

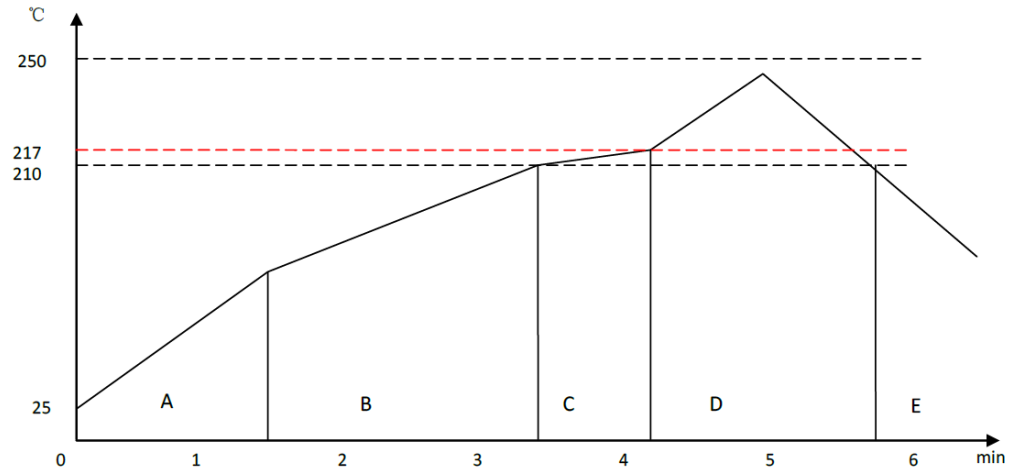

Figure 5-1: Solder Profile

Zone A: Preheat: This raises the temperature at a controlled rate, typically 0.5–2°C/s. This will preheat the component to 120–150°C to distribute the heat uniformly to the PCB.

Zone B: Equilibrium1: In this zone, the flux becomes soft and uniformly spreads solder particles over the PCB board, preventing re-oxidization. The recommended temperature for this zone is 150–200°C for 60–120 seconds.

Zone C: Equilibrium2: This is optional and in order to resolve the upright component issue. Temperature is 210–217°C for 20–30 seconds.

Zone D: Reflow zone: The temperature should be high enough to avoid wetting but low enough to avoid component deterioration. The recommended peak temperature is 230–250°C. The soldering time should be 30–90 seconds when the temperature is above 217°C.

Zone E: Cooling: The cooling rate should be fast to keep the solder grains small, which will give a longer lasting joint. A typical cooling rate is 4°C/s.

>> | A: Regulatory Certifications

Caution: *Unauthorized modifications or changes not expressly approved by Sierra Wireless could void compliance with regulatory rules, and thereby your authority to use this equipment.*

The BC118 module is designed to meet the requirements of the following regulatory bodies and regulations, where applicable:

- Federal Communications Commission (FCC) of the United States
- Innovation, Science and Economic Development Canada (ISED)
- Ministry of Internal Affairs and Communications (MIC) of Japan
- Radio Equipment Directive of the European Union

The following industry certification has been obtained:

- Bluetooth SIG

Additional certifications and details on specific country approvals may be obtained upon customer request — contact your Sierra Wireless account representative for details.

Additional testing and certification may be required for the end product with an embedded BC118 module and are the responsibility of the OEM. Sierra Wireless offers professional services-based assistance to OEMs with the testing and certification process, if required.

United States

The BC118 module has been granted modular approval by the FCC. Integrators may use the BC118 module in their end products without additional FCC certification if the following conditions are met.

- At least 20 cm separation distance between the antenna and the user's body must be maintained at all times.
- The BC118 module must not be collocated with any other transmitter within a host device.
- The regulatory label on the end product must include the text "Contains FCC ID: SSS-BC11X" and the following compliance statement:

This device complies with Part 15 of the FCC Rules. Operation is subject to the following two conditions: (1) This device may not cause harmful interference, and (2) this device must accept any interference received, including interference that may cause undesired operation.

A user manual with the end product must clearly indicate the operating requirements and conditions to ensure compliance with current FCC RF exposure guidelines.

The end product with an embedded BC118 module may also need to meet the FCC Part 15 unintentional emission requirements and be properly authorized per FCC Part 15 Subpart B.

Canada

The BC118 module has been granted modular approval by IC. Integrators may use the BC118 module in their end products without additional IC certification if the following conditions are met.

- At least 20 cm separation distance between the antenna and the user's body must be maintained at all times.
- The BC118 module must not be collocated with any other transmitter within a host device.
- The regulatory label on the end product must include the text "Contains IC : 11012A-BC11X" and the following compliance statement:

This device complies with Industry Canada license-exempt RSS standard(s). Operation is subject to the following two conditions: (1) this device may not cause interference, and (2) this device must accept any interference, including interference that may cause undesired operation of the device.

Le présent appareil est conforme aux CNR d'Industrie Canada applicables aux appareils radio exempts de licence. L'exploitation est autorisée aux deux conditions suivantes: (1) l'appareil ne doit pas produire de brouillage, et (2) l'utilisateur de l'appareil doit accepter tout brouillage radioélectrique subi, même si le brouillage est susceptible d'en compromettre le fonctionnement.

Bluetooth Qualification Program (BQP)

- In case no other non-certified Bluetooth components are incorporated, the BC118's BQP marking certification allows users to integrate the module into products without the need to obtain subsequent and separate approval. 
- The BC118 has been approved by the Bluetooth Qualification Body (BQB) to use the Bluetooth trademark and to offer official Bluetooth functionality. The approval according to the V4.0B Bluetooth specification confirms that the module complies with the Bluetooth specification and will successfully operate with other products supporting the same profile. BQP certification also ensures that the module has gone through safety assessment. This certification was granted through a combination of product performance testing and interoperability testing. This certification applies globally.

Labeling

- Products complying with all relevant requirements are allowed to bear the official Bluetooth logo

For further information regarding the BQP certification requirements please review the following websites:

- Bluetooth Special Interest Group: <https://www.bluetooth.org/apps/content/>