

## Additional Information

### RAINSCREENS

Note: James Hardie has a capillary break requirement when installing HardiePanel on a Multi-Family/Commercial project. Please visit [Jameshardiepros.com](http://Jameshardiepros.com) for further information.

#### The Optional Use of Rain Screen Systems:

James Hardie will support the use of its exterior siding products with rainscreen systems, but does not take responsibility for the entire wall assembly or system.

James Hardie expects the designer or builder using our components as part of the rainscreen system to:

- Adhere to all the installation requirements listed in the relevant product installation instructions.
- Provide adequate details for water management.
- Make the decision about the use of rainscreen.
- James Hardie products does not recommend “drainage mats” or “drainage boards” to provide the necessary capillary break behind our siding. These products can compress during the installation process, impairing the drainage channels and further causing a “wavy” appearance in the plank or panel products.
- Understand the interaction between system components and how each of the components in the system interacts.
- Design of the building envelope accounting for both interior and exterior moisture control.

#### Installation Over Furring:

When installing James Hardie Siding products over furring the question arises what thickness of furring can be used as an alternate to normal metal or wood studs specified in the ESR 1844 & 2290 Report. General rule of thumb is, the specific ESR 1844 & 2290 fastener must be installed into a material that has the same or better holding power than that specified in the ESR 1844 & 2290 and with the same penetration as the ESR 1844 & 2290 fastener.

Note: The ESR 1844 & 2290 is the primary code compliance document James Hardie utilizes, but for other common applications and/or products, additional code compliance documentation and/or fastener specifications may exist. For special circumstances out side the scope of the ESR 1844 & 2290, please contact James Hardie's Technical Services.

When reviewing the following details for attaching to wood furring or framing, an important consideration is that the fastener chosen must be fully encompassed by a wood substrate - the furring may count as all or part of the necessary penetration if it has been proven that the furring and/or wood substrate has the same or better holding power as a timber stud.

#### Design responsibility

In all cases it is the sole responsibility of the architect, envelope engineer or specifier to identify moisture related risks associated with any particular building design and to make any appropriate adjustments or modifications to the installation guidelines given by manufacturers. Wall construction and design must effectively manage moisture, considering both the interior and exterior environment of the building.

#### Attaching lap siding to wood furring:

When attaching lap siding products over wood furring, the typical fastener used is the 1-1/4 in. long No. 11 ga. roofing nail, blind nailed. This fastener is going to be the shortest fastener approved for fastening lap siding products, therefore the furring must be a minimum of 0.75 in thick to achieve the same values as ESR 2290 Table 4 states for the 11 ga. 1-1/4 in roofing nail given plank reveal, stud spacing, building height and exposure category.

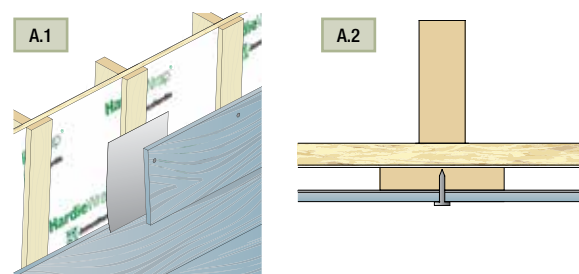

# Appendix A (cont.)

## RAIN SCREENS

### Attaching lap siding to steel furring:

When attaching lap siding products to metal furring, the steel furring must be 20 gauge (33 mils) minimum to 16 gauge (54 mils) maximum. A fastener should be chosen out of the ESR 2290, Table 4, which is approved for attaching to steel framing. Two general rules that should be considered when choosing a fastener is that a nail (pin) must penetrate steel furring  $\frac{1}{4}$  in., and screws must penetrate steel furring 3 full threads. Therefore, if the rules for steel fastening are followed – given plank reveal, stud spacing, building height, and exposure category – the values are the same as ESR 2290, Table 4 states for the chosen fastener.

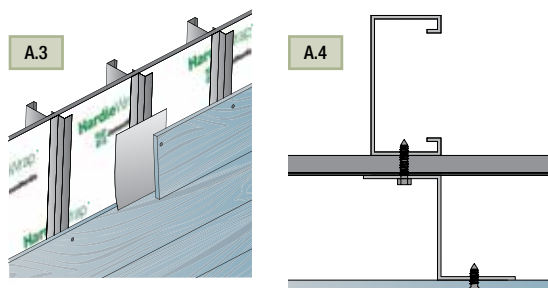

### Attaching panel siding to wood furring:

When attaching panel siding products over wood furring, the typical fastener used is the 6d common 2 in. long nail. This fastener is going to be the shortest fastener approved for fastening panel siding products into wood, therefore the furring must be a minimum of 1-11/16 in. thick to achieve the same values as ESR 1844, Table 4, given stud spacing, building height, and exposure category.

It is deemed an acceptable practice to not fasten along the top and bottom plates for the 5/16 in HardiePanel configurations listed in the ESR 1844, Table 4 using the following fastener type:

- 0.091 in. shank X 0.225 in. HD X 1.5 in. long ring shank nail
- Min No. 8 X 0.311 HD X 1 in. ribbed bugle head screw
- 0.10 X 0.25 in. HD X 1.5 in. long ET&F pin or equivalent
- 6d common 2 in. long nail

### Conditions of use:

- This practice is acceptable for transverse load only.
- This practice is not acceptable for racking shear values or in-plane forces other than perpendicular/normal wind forces.
- All vertical joints shall occur over framing.
- All other James Hardie Installation Requirements shall be followed.

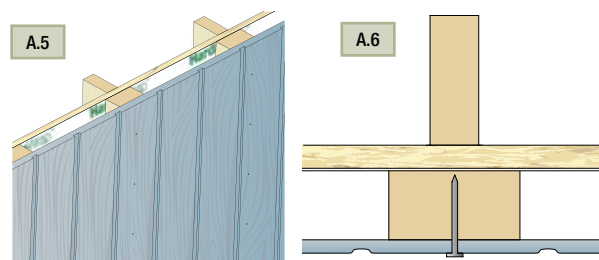

### Attaching panel siding to steel furring:

When attaching panel siding products to metal furring, the steel furring must be 20 gauge (33 mils) minimum to 16 gauge (54 mils) maximum. A fastener should be chosen out of the ESR 1844, Table 4, which is approved for attaching to steel framing. Two general rules that should be considered when choosing a fastener is that a nail (pin) must penetrate steel furring  $\frac{1}{4}$  in., and screws must penetrate steel furring 3 full threads. Therefore, if the rules for steel fastening are followed – given stud spacing, building height, and exposure category – the values are the same as ESR 1844, Table 4 states for the chosen fastener.

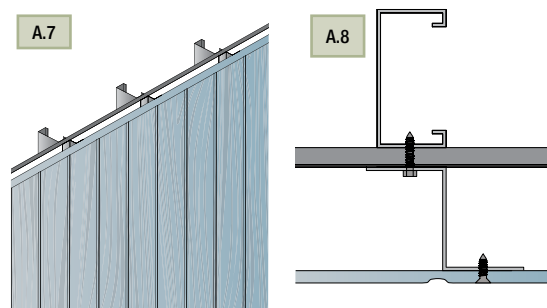

## ATTACHING JAMES HARDIE PRODUCTS TO INSULATED CONCRETE FORMS (ICF)

Considering the proprietary nature of Insulated Concrete Forms (ICF) and the number of ICF manufacturers currently selling product in the US and Canada, James Hardie Building Products cannot calculate or determine the proper fastener for each type of plastic or metal cross-tie flange being used in the field. James Hardie offers the following as a guide to determine the correct siding fastening to be used with the respective ICF system chosen for the project in question.

1. Determine the projects basic wind design, including basic wind speed, wind exposure category, and mean roof height. Find the fastener and frame type within James Hardie's ICC-ES Product Evaluation Report (e.g. ESR 1844 & 2290) that will meet the project's basic wind design.
  - a. Take note of the head diameter, shank diameter, and fastener length for the fastener.
  - b. Take note of the frame type and frame spacing.

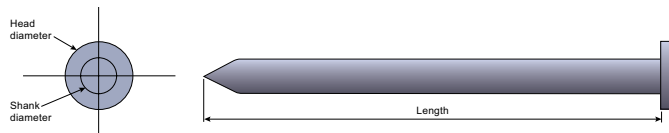

Note: Fastener bearing area is equal to the head area less the shank area.

3. Go to the ICF system manufacturer and find a fastener that is similar in dimension to the fastener from step 2.1 above.
  - a. Basically, the bearing area under the ICF fastener head shall be the same as or greater than the bearing area under the James Hardie fastener head from step 2.
4. Since the James Hardie siding product has to be attached to a structural member, in this case the ICF cross-tie flange, the steps below shall be followed.
  - a. The onus is on the ICF system manufacturer to demonstrate that their ICF cross-tie flange holds fasteners, screws or nails, the same as wood or steel framing hold screws or nails.
  - b. ICF fastener allowable withdrawal load capacity (applicable factor of safety applied) may be found in an ICC-ES Product Evaluation for the given ICF manufacturer's products, OR
  - c. The ICF manufacturer may have testing that shows their fastener's allowable withdrawal load capacity (applicable factor of safety applied) from their cross-tie flange.
5. For the fastener from step 2, a registered design professional shall calculate the allowable withdrawal load (factor of safety applied) from the frame type noted in step 2.2.
6. A registered design professional shall then make an equivalency statement comparing the ICF fastener withdrawal (step 4.1.1 or step 4.1.2) versus the fastener withdrawal from step 5.
7. When the ICF cross-tie flange spacing differs from the James Hardie frame spacing in step 2.2, a registered design professional shall calculate the maximum siding fastener spacing into the cross-tie flange needed to resist the applicable basic wind speeds published in James Hardie's ESR 1844 & 2290 for the fastener and design from step 2.
8. When required by the code official and once in possession of the information gathered in the steps above it is the responsibility of the property owner, design professional, contractor, or installer to make his or her case to the Building Official<sup>1</sup>.

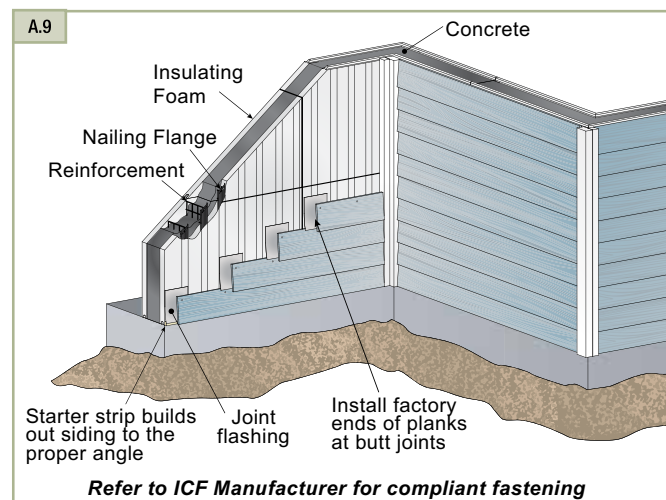

<sup>1</sup>The Building Official reserves the right to approve alternate materials, design and methods of construction, 2006 International Building Code® Section 104.11, 2006 International Residential Code® Section R104.11, and 1997 Uniform Building Code™ Section 104.2.8.

# Appendix A (cont.)

## ATTACHING HARDIEPLANK® LAP SIDING AND HARDIETRIM® PRODUCTS TO CONCRETE MASONRY UNITS (CMU)

The application of HardiePlank® Lap Siding and HardieTrim® boards to masonry construction complying with local building codes using Concrete Masonry Units (CMU) complying to ASTM C 90 can be achieved by using one of the following two methods of attachment. All other product specific installation requirements which are not outlined below must be followed.

### Method 1: Attachment Over Furring

Attach over furring with adequate thickness to allow attachment with approved fastening methods according to local building codes and code compliance documentation. Furring must be attached to ensure it can transfer the wind loads and other necessary forces back to the structure. The mechanical connection of the furring to the structure is the responsibility of the Licensed Design Professional. James Hardie Building Products has no comment on the load carrying capacity of the furring to framing connections.

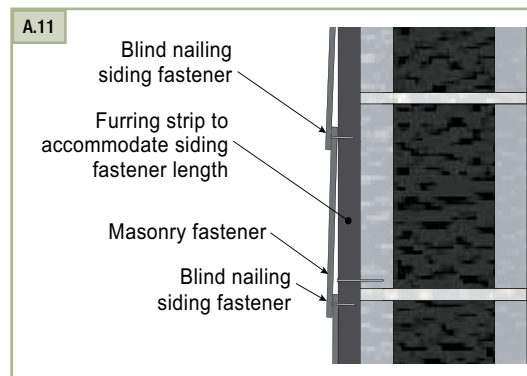
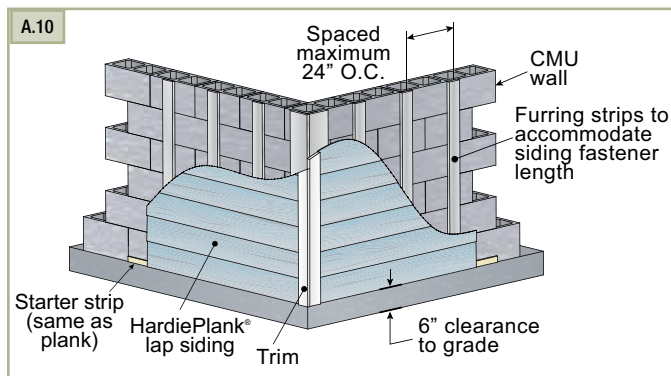

### Method 2: Attachment Directly to CMU

Attach directly to masonry with approved fastening method according to local building codes and code compliance documentation. Refer to and follow local building codes for water resistive barrier requirements.

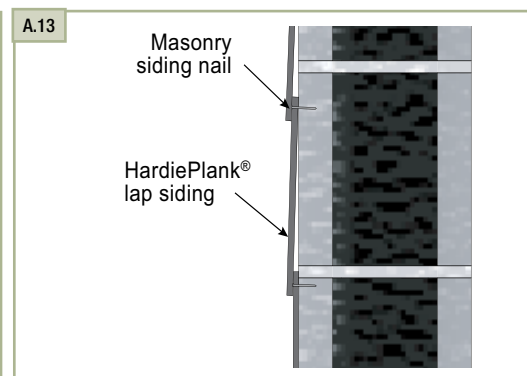
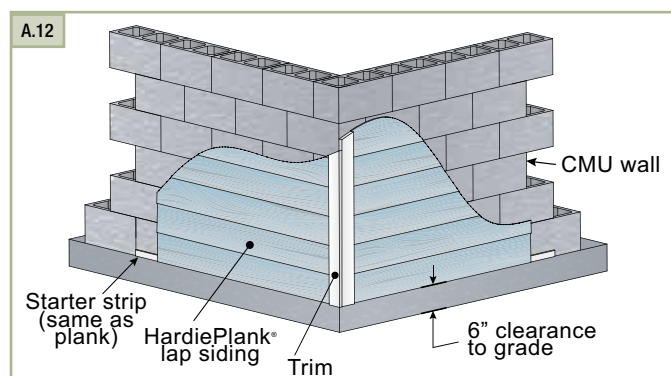

### Fastening to CMU

For information on fastening James Hardie products to CMU refer to ESR 1844 & 2290

### Attachment of HardieTrim® boards

HardieTrim boards can be fastened using hardened finish nails designed for masonry construction. For more information refer to the HardieTrim section of this guide.

## WEATHER BARRIER & RIGID FOAM

- When using a weather resistive barrier (WRB) in conjunction with rigid foam insulation, the WRB can be installed underneath the foam as shown, or over the top if more convenient
- Regardless of where the WRB is placed all flashings must be incorporated into the WRB and drainage plane.
- Some rigid foam insulation products are manufactured with tongue & groove or shiplap joints and can be used as the WRB when properly installed and sealed. When using rigid foam insulation as the WRB refer to manufacturers installation instructions.

### Trim

Depending upon the reveal around windows, doors, and penetrations, thickness of foam and the type and thickness of trim used there will be different techniques to install the siding and trim to ensure the foam is completely concealed.

### Flashings

The Z flashing above all horizontal trim must be incorporated into the WRB regardless of WRB position. If the foam is being used per manufacturers instructions as the WRB, all flashings must be incorporated into the drainage plane such that it allows moisture to drain down and out.

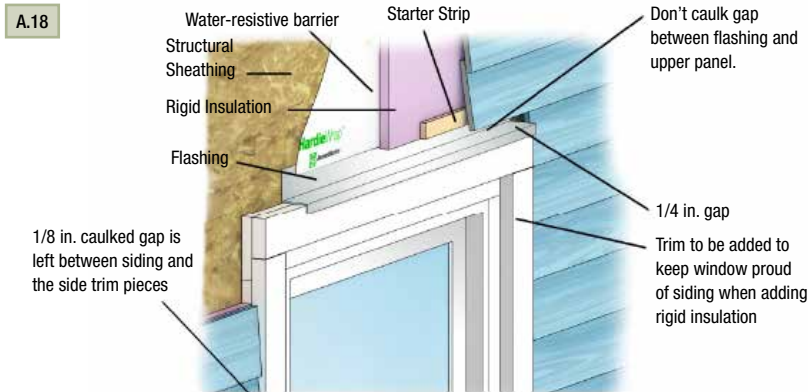

**A.17**

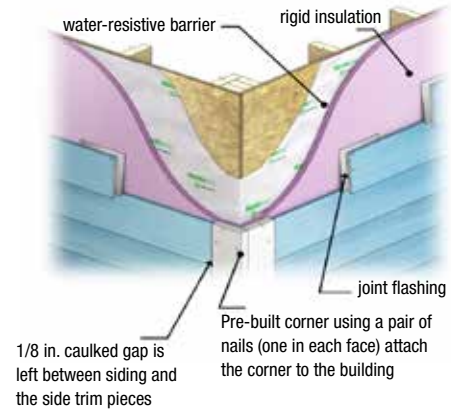

**Note:** It is recommended to layout the rigid foam insulation such that vertical joints do not occur at the corners of window and door openings or overs if possible.

# Appendix A (cont.)

## JOINT FLASHING WITH HARDIEPLANK® LAP SIDING

One or more of the following joint treatment options are required by code (as referenced 2009 IRC R703.10.2)

- Joint Flashing (James Hardie recommended)
- Caulking\* (Caulking is not recommended for ColorPlus for aesthetic reasons as the Caulking and ColorPlus will weather differently. For the same reason, do not caulk nail heads on ColorPlus products.)
- “H” jointer cover Flashing behind butt joints provides an extra level of protection against the entry of water at the joint.

James Hardie recommends 6 in. wide flashing that overlaps the course below by 1 in. Some local building codes may require different size flashing. Joint-flashing material must be durable, waterproof materials that do not react with cement products. Examples of suitable material include finished coil stock and code compliant water-resistive barriers. Other products may also be suitable.

### The reasons for this are:

- The use of joint flashing behind field butt joints is an approved joint treatment method as described in the 2006 International Building Code and is recognized by James Hardie and experts across the building industry to be a superior method.

*“1405.17.2 Horizontal lap siding. Lap siding shall be lapped a minimum of 1 1/4 inches (32 mm) and shall have the ends sealed with caulking, covered with an H section joint cover or located over a strip of flashing.”*

Experts across the industry recognize flashings as an effective and responsible method for draining a wall system:

*“The fundamental principle of water management is to shed water by layering materials in such a way that water is directed downwards and outwards out of the building or away from the building. The key to this fundamental principle is drainage. The most elegant expression of this concept is a flashing. Flashings are the most under-rated building enclosure component and arguably the most important.”*

EEBA (Energy & Environmental Building Association™) Water Management Guide By Joseph W. Lstriburek, Ph.D., P.eng. June 2004.

- Reduced maintenance required by the home owner – It is recognized by James Hardie, several caulking manufacturers, experts across the industry, and experienced home owners that when caulking is used at field butt joints, maintenance will be required. Depending on the specific product and the application, caulked field butt joints will need to be maintained to guarantee continued performance over the life of the building. In addition, several sealant/caulking manufacturers recommend against using their products at butt joints in fiber cement siding for many of the reasons discussed here.

- Improved appearance – When installed properly, flashing at a field butt joint can create a better looking joint. James Hardie recommends butting field joints together in moderate contact which achieves a more continuous looking joint. When utilizing a caulked butt joint, a gap specified by the caulk manufacturer must be left at the joint. Over time as the caulk ages, this joint can become pronounced on the wall and stand out.

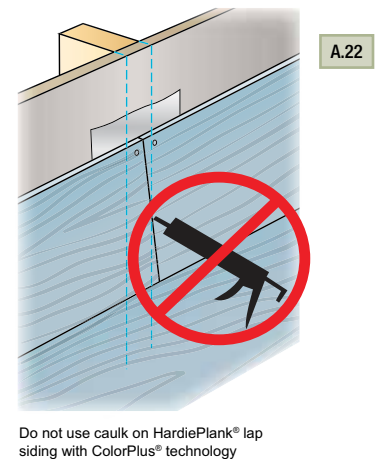
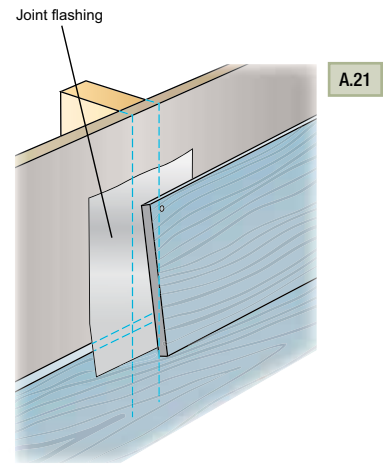

## JAMES HARDIE REQUIREMENTS FOR ALTERNATE FASTENERS AND METHODS OF FASTENING

The fastening requirements for each product are stated in one or more of the following technical documents and in some cases fastener products may be referenced. Below are the steps that can be used to demonstrate an alternate fastener's equivalency to the James Hardie published fastening requirements.

1. It is the responsibility of either the property owner, design professional, contractor, or installer to consult:
  - a. The fastener Manufacturer for a Product Listing Specification or Code Compliance report that covers the installation method in question, or;
  - b. A licensed Architect or Professional Engineer to make an equivalency statement linking the alternate fastener (or fastening method) to the fastening requirements published within the relevant James Hardie technical document;
2. Once in possession of the information gathered in step one it is the responsibility of the property owner, design professional, contractor, or installer to make his or her case to the Building Official<sup>1</sup>

<sup>1</sup>The Building Official reserves the right to approve alternate materials, design and methods of construction, 2006 International Building Code® Section 104.11, 2006 International Residential Code Section R104.11, and 1997 Uniform Building Code Section 104.2.8. All national, state, and local building code requirements must be followed and where they are more stringent than the James Hardie installation requirements, state and local requirements will take precedence.

# Appendix B

## Estimating

### Siding

All houses can be broken down to triangles, rectangles, and squares. Using these simple shapes it is very easy to estimate the amount of siding required.

1. Break down the portions of the house to be sided into the simple shapes (squares, rectangles, triangles) Figures 12.1 - 12.4.
2. Determine the height and width of each shape.
3. Multiply height x width to determine square footage. For triangles divide the total by 2.
4. Add all of the square footage numbers together.
5. Subtract large items such as garage doors, large doors, large windows, and banks of windows from total.  
Do not remove small windows, doors, vents, or other small areas not being sided.
6. Total all numbers. This gives you the total covered area.
7. Use the coverage charts located in this section to determine the number needed.
8. Add a minimum of 5% for waste. If there are multiple (3 or more) gables, chases, bump outs, or dormers add 10%.\*

\* Material for starter strip is included in the calculation for waste.

### Trim

Number of HardieTrim® Boards:

Trim is applied to corners and around doors and windows. Trim is also used for fascia board, rake board, band board, frieze board and other details.

1. Determine which areas are to be trimmed.
2. Measure all openings to be trimmed including doors, windows, vent openings, corners (inside and outside), and other areas.
3. Measure for fascia, rakes, and frieze boards.
4. Add the lengths for corners, fascia, rakes, and frieze and add 5% for waste.
5. Add the lengths for window and door trim and add 10% for waste.
6. Add the total from lines 4 and 5 to determine the amount of trim needed.

Disclaimer: The estimation methods in this section are meant as a guide. James Hardie does not assume responsibility for over or under ordering of product.

B.1 Wall Area

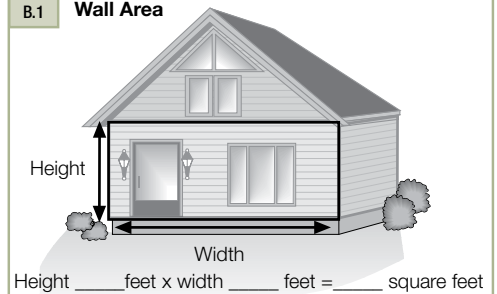

B.2 Gable Area

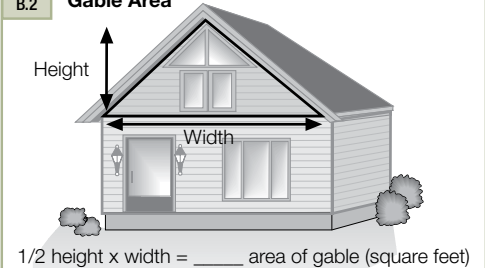

B.3 Gambrel Roof House

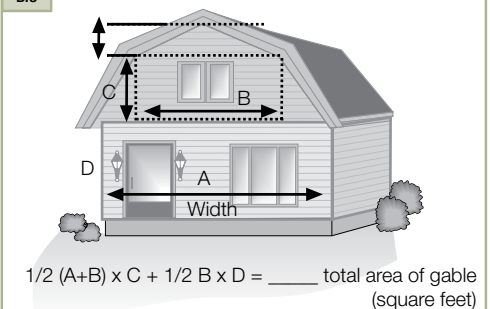

B.4 Dormer Area

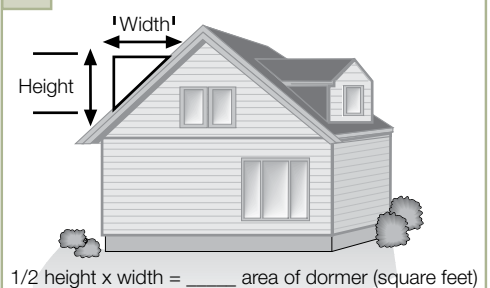

B.5

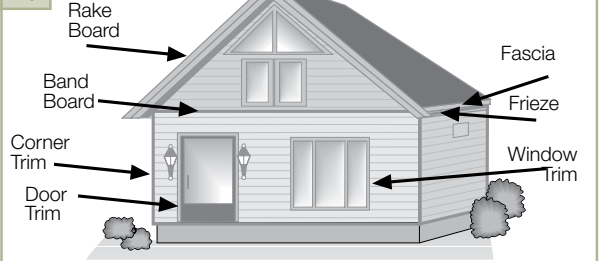

### HardiePlank® Lap Siding Coverage Chart\* (number of planks)

### HardiePanel® Vertical Siding Coverage Chart\* (number of panels)

Coverage Area (square feet)	Plank Width (in)					
	W. (in) 5.25 Exp. (in) 4	6.25 5	7.25 6	8.25 7	9.25 8	12 10.75
100	25	20	17	14	13	9
200	50	40	33	29	25	19
300	75	60	50	43	38	28
400	100	80	67	57	50	37
500	125	100	83	71	63	47
600	150	120	100	86	75	56
700	175	140	117	100	88	65
800	200	160	133	114	100	74
900	225	180	150	129	113	84
1000	250	200	167	143	125	93
1100	275	220	183	157	138	102
1200	300	240	200	171	150	112
1300	325	260	217	186	163	121
1400	350	280	233	200	175	130
1500	375	300	250	214	188	140
1600	400	320	267	229	200	149
1700	425	340	283	243	213	158
1800	450	360	300	257	225	167
1900	475	380	317	271	238	177
2000	500	400	333	286	250	186
2100	525	420	350	300	263	195
2200	550	440	367	314	275	205
2300	575	460	383	329	288	214
2400	600	480	400	343	300	223
2500	625	500	417	357	313	233
2600	650	520	433	371	325	242
2700	675	540	450	386	338	251
2800	700	560	467	400	350	260
2900	725	580	483	414	363	270
3000	750	600	500	429	375	279

Coverage Area (square feet)	Panel Size (ft)		
	4x8 (32SF)	4x9 (36SF)	4x10 (40SF)
100	4	3	3
200	7	6	5
300	10	9	8
400	13	12	10
500	16	14	13
600	19	15	15
700	22	20	18
800	25	23	20
900	29	25	23
1000	32	28	25
1100	35	31	28
1200	38	34	30
1300	41	37	33
1400	44	39	35
1500	47	42	38
1600	50	45	40
1700	54	48	43
1800	57	50	45
1900	60	53	48
2000	63	56	50
2100	66	59	53
2200	69	62	55
2300	72	64	58
2400	75	67	60
2500	79	70	63
2600	82	73	65
2700	85	75	68
2800	88	78	70
2900	91	81	73
3000	94	84	75

### Nail Coverage Chart\*\* (number of nails)

Coverage Area (square feet)	Plank Width (in)					
	Width (in) 5.25 Exposure (in) 4	6.25 5	7.25 6	8.25 7	9.25 8	12 10.75
100	250	200	166	143	125	93
500	1250	1000	830	715	625	465
1000	2500	2000	1660	1430	1250	930

The estimation methods in this section are meant as a guide. James Hardie does not assume responsibility for over or under ordering of product.  
\*Coverage chart does not include waste. \*\* Number of nails given are for building framed 16 in o.c.

# Appendix B (cont.)

## HardieShingle® Siding

### HardieShingle Staggered Edge Notched Panel Coverage

Panels are available in 48 in. lengths. Pieces needed for one square (100 sq. ft) of product coverage = approximately 50, (depending on ratio of length to height of wall) based on maximum exposure of 6 in.

### HardieShingle Straight Edge Notched Panels Coverage

Panels are available in 48 in. lengths. Pieces needed for one square (100 sq. ft) of product coverage = approximately 43, (depending on ratio of length to height of wall) based on maximum exposure of 7 in.

### HardieShingle Half-round Notched Panel Coverage

Panels are available in 48 in. lengths. Pieces needed for one square (100 sq. ft.) of product coverage = approximately 43, based on a maximum exposure of 7 in.

### HardieShingle Individual Shingle Coverage\*

Shingles are available in 4.2 in., 5.5 in., 6.75 in., 7.25 in. and 10 in. widths, Bundles needed for one square (100 sq. ft.) of product coverage:

Shingle Width	# of Bundles (5 in Exp.)	# of Bundles (7 in Exp.)	Pieces per Bundle (5 in Exp.)	Pieces per Bundle (7 in. Exp.)
4.2 in.	3	3	20	15
5.5 in	6	6	20	15
6.75 in	6	3	20	15
7.25 in	6	6	20	15
10 in	3	3	20	15

\* Individual shingles are not available in all areas. Check you local dealer for availability.

### HardieSoffit® Panels

- For 12 in. and 16 in. width soffits: Divide total lineal footage of soffit and/or eaves by 12.
- For 24 in. width soffits: Divide total lineal footage of soffit and/or eaves by 8.

## Glossary of Building Terms

**Back Roll** - To roll over a freshly spray painted surface with a roller.

**Back Sealing/Priming** - Back sealing and back priming are used interchangeably in the field and refer to the act of applying a sealer or primer to the back of a cladding material to minimize the potential for water absorption through the backside of the product.

**Band Board** - A decorative piece of trim placed between two floors along the rim joist.

**Bevel Cut** - See weather cut

**Blind Nailing** - The action of placing a fastener through the top edge of lap siding that will be covered by the next course of siding.

**Bump Out** - A built out protrusion from a building.

**Butt Joint** - To place materials end-to-end or end-to-edge without overlapping. Also known as a field joint.

**Caulk** - A compound used to fill cracks, gaps, seams and joints.

**Chase** - A framed enclosed space around a flue pipe or a channel in a wall, or through a ceiling for something to lie in or pass through.

**Course** - A row of planks, one plank wide running the length of the house.

**Dormer** - A gabled extension built out from a sloping roof to accommodate a vertical window.

**Drip Cap** - A molding or metal flashing placed on the exterior topside of a door or window frame to cause water to drip beyond the outside of the frame.

**Drip Edge** - A metal or vinyl flashing placed on the top edge of the roof sheathing which directs water away from the structure to prevent seepage under or behind the exterior trim or fascia.

**Eave** - The lower part of the roof that projects over the exterior wall assembly.

**Electro-Galvanized** - Covered with zinc using a plating process.

**Face** - The side of the siding, trim, or soffit showing once the product has been installed.

**Face Nailing** - The action of placing a fastener through the overlap of a plank. The fastener will be visible.

**Fascia Board** - A trim board attached to the ends of the rafters.

**Finished Grade** - The level at which the ground surface meets the foundation of a building.

**Flashing** - A thin flat metal positioned under/behind roofing, windows, doors, corner posts, etc. to keep draining water from penetrating the house.

**Frieze Board** - A horizontal member connecting the top of the siding with the soffit

**Furring/Furring Strip** - Furring strips are long, thin strips of wood, metal or Fiber Cement used to make backing surfaces to support the finished surfaces.

**Gable** - The end of a wall that is created when a roof line is pitched and slopes in two directions.

**Galvanized** - Covered with zinc. Either hot-dipped or electro-plated.

**Grade** - The height of the ground on which something stands.

**Horizontal** - Parallel to the horizon; on a level.

**Joint Flashing** - An additional weather resistive barrier placed behind a butt joint.

**Lap** - To over lap a course of siding with another course of siding.

**Level** - A position of measurement truly and exactly horizontal, 90° from a plumb surface.

**Light Block** - Decorative trim item placed under light fixtures and other exterior fixtures.

**Miter** - To make a diagonal cut, beveled to a specific angle 45° and 22 1/2 ° are common.



## Appendix C (cont.)

**Mud Sill** - A building member resting and normally attached to the foundation of a building running around the perimeter of the building. Also known as sill plate.

**OSB** - Oriented Strand Board. A common type of structural panel sheathing.

**PEL** - Permissible Exposure Limit. The maximum daily exposure level to respirable silica. OSHA's Personal Exposure Limit is 0.05 mg/m<sup>3</sup>.

**Plumb** - A position of measurement truly and exactly vertical, 90° from a level surface.

**Plunge Cut** - The act of driving a saw into the body of a material.

**Rafter Tail** - The end of a rafter extending past the wall assembly.

**Rain Screen Wall** - Consists of an exterior cladding, a cavity behind the cladding typically created through the use of furring strips for the purpose of drainage and venting to the outside; an innerwall plane incorporating a weather resistive barrier.

**Rake Board** - Decorative trim placed at an angle.

**Rigid Sheathing** - Plywood or OSB.

**Rim Joist** - The board that the rest of the joists are nailed to. It runs the entire perimeter of the house.

**Rip Cut** - Cut along the grain, usually lengthwise on a board.

**Scroll Work** - Decorative trim work.

**Sheathing** - Sheets of plywood, gypsum board, or other material nailed to the outside face of studs as a base for exterior siding.

**Shim** - A building material, usually wood, used to even a surface.

**Silica** - Mineral that is composed of silicon dioxide, SiO<sub>2</sub>.

**Speed Square** - Triangle shaped measuring device used in a variety of framing and siding applications.

**Stage** - To deliver, stack, or store material in a specific location.

**Starter Strip** - An accessory used under the first course of siding to provide a consistent plank angle.

**Sub-Fascia** - Framing member attached to the rafter tails used to support the fascia or used to pad out the fascia.

**T-Shed** - A shed with a single vertical wall and a roof that hangs off that wall on either side. The cross section of the shed is shaped like a 'T'.

**Vertical** - Being or situated at right angles to the horizon; upright.

**Weather Cut**- 15° to 45° cut used to join two boards.

**Weather-Resistive Barrier**- A building paper that protects building materials from exterior water penetration.

**Z-Flashing**- A piece of flashing bent into the shape of a "z". Used over window trim, band boards, panel intersections, and other vertical surfaces.



## Code References

Note: All building work must be in accordance with the applicable local building codes. The following is a list of the key code clauses. It is provided as a reference tool and not intended to be a substitute for proper design of approved construction. ASTM E1825 also provides guidance on the evaluation of materials, products and systems used in exterior wall construction.

### Site and Foundations

2003,2006,2009,2012, 2015 International Building Code  
Chapter 18 Foundations and Retaining Walls  
1803.3 (03,06) Site grading; 1804.3 (09,12) Site grading;  
1804.4 (15) Site grading

2003 2006, 2009, 2012, 2015 International Residential Code for One- and Two- Family Dwellings  
Chapter 4 Foundations  
R401.3 Drainage

### Ground Clearances

2003, 2006, 2009, 2012, 2015 International Building Code  
Chapter 18 Foundations and Retaining Walls  
1803.3 (03,06) Site grading; 1804.3 (09,12) Site grading;  
1804.4 (15) Site grading  
Chapter 23 Wood  
2304.11.2.2 (03, 06, 09, 12) Wood supported by exterior foundation walls.

2304.12.1.2 (15) Wood supported by exterior foundation walls  
2003, 2006, 2009, 2012, 2015 International Residential Code for One- and Two- Family Dwellings  
Chapter 3 Building Planning  
Chapter 4 Foundations  
R404.1.6 Height above finished grade

### Moisture Management

2003, 2006, 2009, 2012, 2015 International Building Code  
Chapter 14 Exterior Walls  
1404.1 General  
1404.2 Weather-resistive barrier  
1405.1 General  
1405.2 Weather Protection  
1405.3 Flashing (03,06)  
1405.4 Flashing (09,12, 15)  
1405.17 (03,06) Joints  
1405.16 (09,12, 15) Joints

2003, 2006, 2009, 2012, 2015 International Residential Code for One- and Two- Family Dwellings  
Chapter 7 Wall Covering  
R703.2 Weather-resistant barrier  
R703.8 Flashing  
R703.10 Joints

### Wall Construction

2003, 2006, 2009, 2012, 2015 International Building Code  
Chapter 22 Steel  
Chapter 23 Wood

2003, 2006, 2009, 2012, 2015 International Residential Code for One- and Two- Family Dwellings  
Chapter 6 Wall Construction  
R602.10 Wall bracing

### Fastening

2003, 2006, 2009, 2012, 2015 International Building Code  
Chapter 14 Exterior Walls  
1405.15 (03,06) Fiber cement siding  
1405.16 (09,12, 15) Fiber cement siding  
1406.2.2 (03, 06) Architectural trim  
1406.2.2.2( 09) Trim  
1406.2 (12, 15) Combustible exterior wall coverage

2003, 2006, 2009, 2012, 2015 International Residential Code for One- and Two- Family Dwellings  
Chapter 7 Wall Covering  
R703.4 (03, 06, 09, 12) Attachments  
R703.3 (15) Nominal thickness and attachments

To find the most current ESR reports please visit [www.icc-es.org](http://www.icc-es.org) and reference below for the corresponding ESR number for that product.

**HARDIEPLANK® LAP SIDING  
& HARDIESHINGLE® SIDING**

**ESR 2290**

**HARDIEPANEL®  
VERTICAL SIDING**

**ESR 1844**

**HARDIESOFFIT®  
PANELS**

**ESR 2273**

**HARDIEBACKER®  
CEMENT BOARDS**

**ESR 2280**

**HARDIEWRAP®  
WEATHER BARRIER**

**ESR 2658**