

July 13, 2021

## THE FACTS ABOUT THRUST RESTRAINT AND DUCTILE IRON PIPE

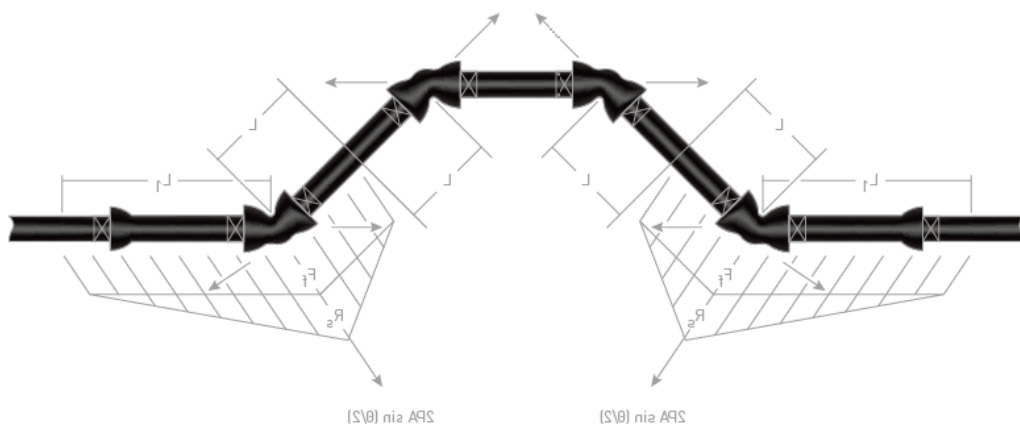

An important aspect of water pipeline design is consideration of thrust forces that are present whenever a pipeline changes direction or changes size through a fitting, such as a bend, reducer, or tee, etc. Unless these thrust forces are addressed, the joints of the pipeline at the fitting can separate.

Thrust restraint in underground pipelines is achieved by transferring the thrust force to the soil structure surrounding the pipe. The most popular methods of doing so are through the use of thrust blocks or restrained joints.

### Thrust Restraint Design for Ductile Iron Pipe | DOWNLOAD NOW

In modern pipeline designs, restrained joints have become a very popular method of handling thrust forces. They work by resisting separation of the joints along a calculated length of pipe, which allows that length of pipe to interact with the soil and counter the thrust forces. The joints of the pipe outside of that length of pipe are no longer at risk of separation. Restrained joints rely on friction between the pipe surface and the soil and, in most fittings, the resistance of the soil to movement of the pipe.



To help in restrained joint design, DIPRA provides a free online thrust restraint calculator that can be used to calculate the required lengths of pipe to determine the unit frictional force, unit bearing resistance, and required restrained length for the most common restrained joint designs.

### TRY OUT OUR THRUST RESTRAINT CALCULATOR

Thank you,  
Patrick Hogan  
President, DIPRA