

INSTALLATION GUIDE - HOW TO CONSTRUCT A STEPOC CORNER (200mm)

Depending on the type of construction it may be necessary to incorporate corners. This can be carried out very simply using standard components from the Stepoc range. Following this simple process will help to speed up the construction of the structure.

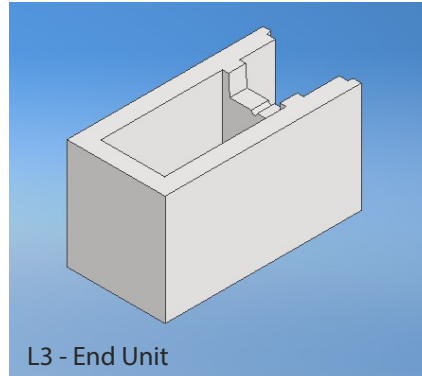
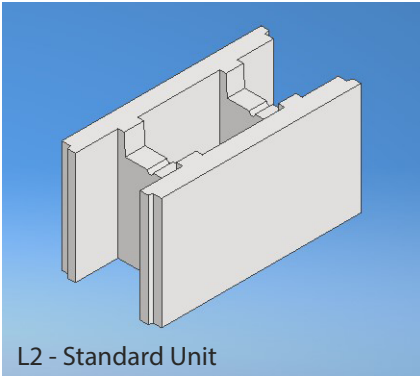

It is always recommended to construct corners and ends first and build away from these points.

Any cuts can then be incorporated into the middle of the wall.

Ensure vertical starter bars are in the correct position and at the correct centres (multiples of 200mm).

Stepoc Corner Construction

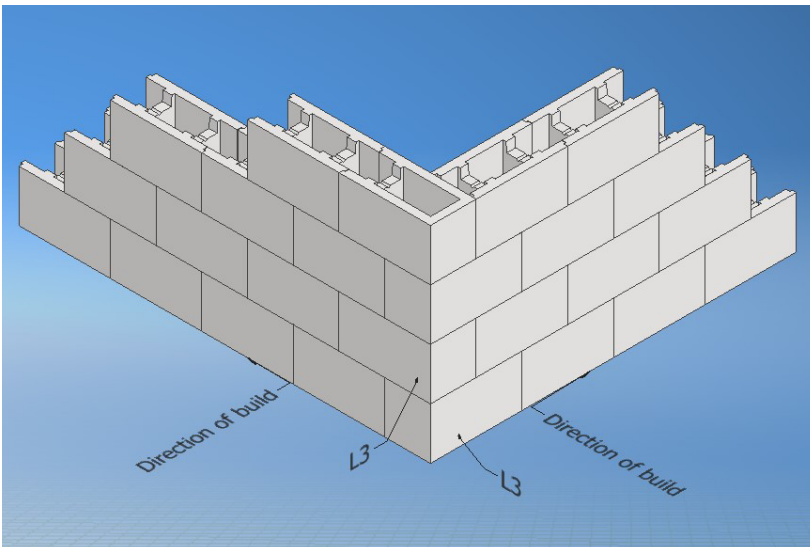

1. Place L3 End Unit at corner and build away using L2's.
2. Place L2 Standard Unit up to side of L3 and build away using L2's.
3. Notch out the side wall of L3 to allow horizontal reinforcement to be positioned.
4. Repeat process placing L3 in opposite orientation.

Additional Information

200mm Stepoc can be constructed up to 8 courses high (1800mm) before filling with concrete. It is recommended to use some temporary propping at corners during the concreting process. Pour heights on site will be determined by particular circumstances but it is recommended that where multiple pours are used the concrete is left 75mm down from the top of the block to allow for a key with the subsequent pour.

Concrete Infill – 0.12m³/m²

Concrete specification to Structural Engineers design but no less than C32/40 with a slump category S4 and a maximum aggregate size of 10mm. Cover to vertical reinforcement should be minimum 40mm