

## INSTALLATION GUIDE - HOW TO CONSTRUCT A STEPOC CORNER (256mm)

Depending on the type of construction it may be necessary to incorporate corners. This can be carried out very simply using standard components from the Stepoc range. Following this simple process will help to speed up the construction of the structure.

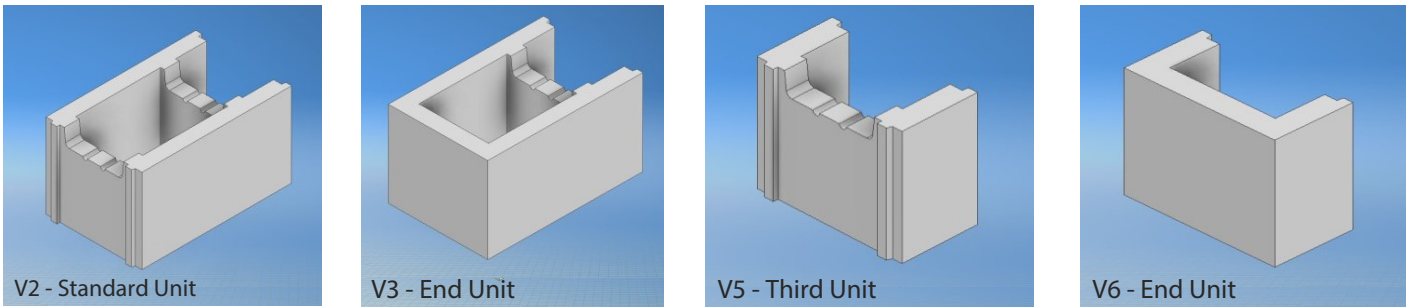

It is always recommended to construct corners and ends first and build away from these points. Any cuts can then be incorporated into the middle of the wall. Ensure vertical starter bars are in the correct position and at the correct centres (multiples of 133mm).

### Stepoc Corner Construction

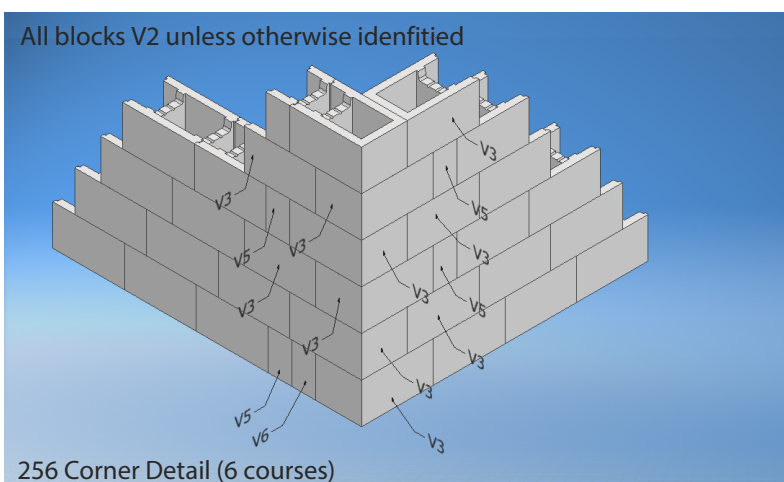
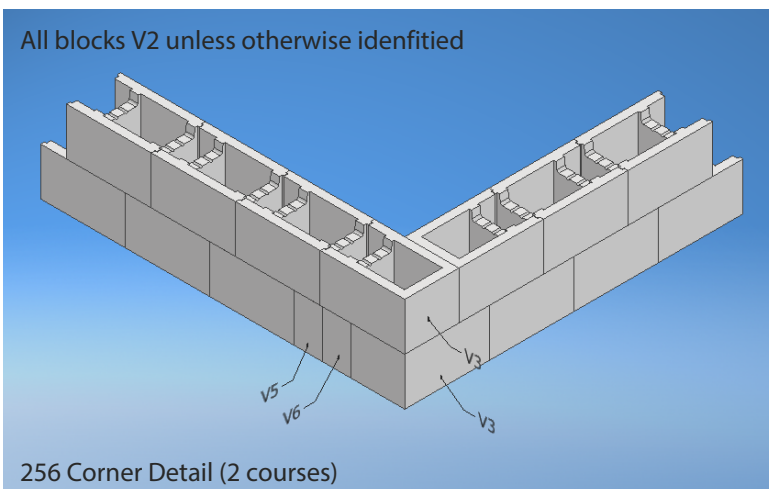

1. Place V3 End Unit at corner and build away following configuration to achieve one third bond. (drawing ST-256-CRN)
2. Place V6 Standard Unit up to side of V3 and then a V5 unit and build away using V2's.
3. Notch out the side/end wall of V3 to allow horizontal reinforcement to be positioned.
4. Start 2nd course with V3 on top of 1st course V3 facing in opposing orientation.
5. Keep constructing corner following sequence as shown in drawing ST-256-CRN.
6. Pattern repeats after 6 courses.

## **INSTALLATION GUIDE - HOW TO CONSTRUCT A STEPOC CORNER (256mm)**

### **Additional Information**

256mm Stepoc can be constructed up to 10 courses high (2250mm) before filling with concrete. It is recommended to use some temporary propping at corners during the concreting process. Pour heights on site will be determined by particular circumstances but it is recommended that where multiple pours are used the concrete is left 75mm down from the top of the block to allow for a key with the subsequent pour.

Concrete Infill – 0.15m<sup>3</sup>/m<sup>2</sup>

Concrete specification to Structural Engineers design but no less than C32/40 with a slump category S4 and a maximum aggregate size of 10mm. Cover to vertical reinforcement should be minimum 40mm