



CAST STONE BAT & SWIFT BOX

ECO HABITATS FOR BATS

In the UK there are 17 species of bat, all of which are protected by law. The Forticrete enclosed Bat Box has been developed to be used in new build construction or renovation work where there is a requirement to provide a habitat for Pipistrelle bats.

- The box is made of a conventional cast stone front face but is backed with high grade plywood which is sawn and roughened internally to provide a haven for bats.
- The Bat Box is maintenance free due to the bottom entrance.
- Bat boxes are available from Forticrete's Stone in Stock range without the motif. Bespoke boxes can be designed and made for any application. Box motifs available as an optional extra.

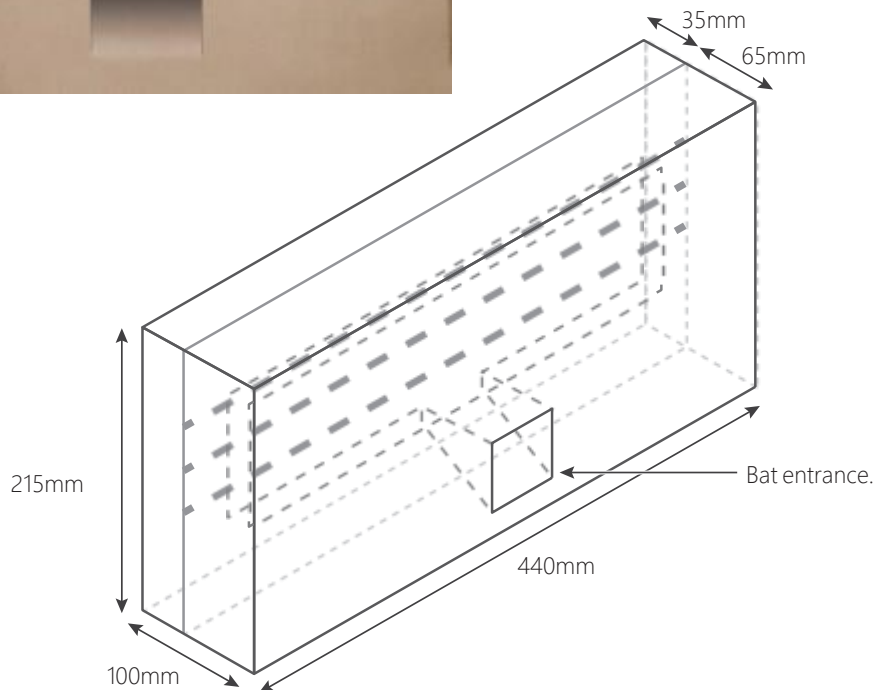



CAST STONE **BAT & SWIFT BOX**

Pipistrelles are crevice dwellers and this design replicates the type of environment they would head for in nature. The dimensions of the Bat Box are designed to course with standard masonry.

The unit is not intended to allow inspection. Opening a bat box is inadvisable in case of inadvertently harming the inhabitants. Bats do not like draughts so the sealed design of the box is ideal. Place 4 or 5 metres from ground level close to trees or hedgerow as bats prefer to enter their nest under relative cover. They can also use these for echo location. However the approach to

the box should be clear of obstacles such as ivy, tree branches etc.

Two to four boxes should be close-by but facing different directions to make the most of different temperatures dependent on time of year. Bats like constant temperature and humidity. Positioning to avoid prevailing wind and rain should be considered.

For further information on encouraging and living alongside these remarkable creatures contact the Bat Conservation Trust.





CAST STONE **BAT & SWIFT BOX**

ECO HABITATS FOR SWIFTS

Swifts come to the UK for just a few months each summer from Central and Southern Africa.

Despite legal protection their numbers are declining.

Since Roman times they have made their homes in man-made buildings however they are finding it increasingly difficult to find nest sites in modern or refurbished buildings due to the effective sealing of the eaves.

Swifts often bond at a year old but only start nesting at four. They pair for life and will return to the same nest site year on year. The oldest recorded swift was 21 years old according to the RSPB.

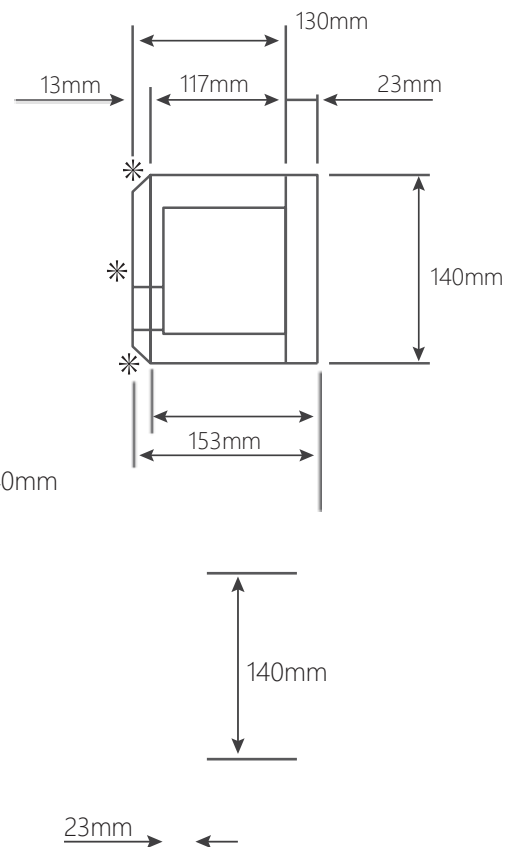
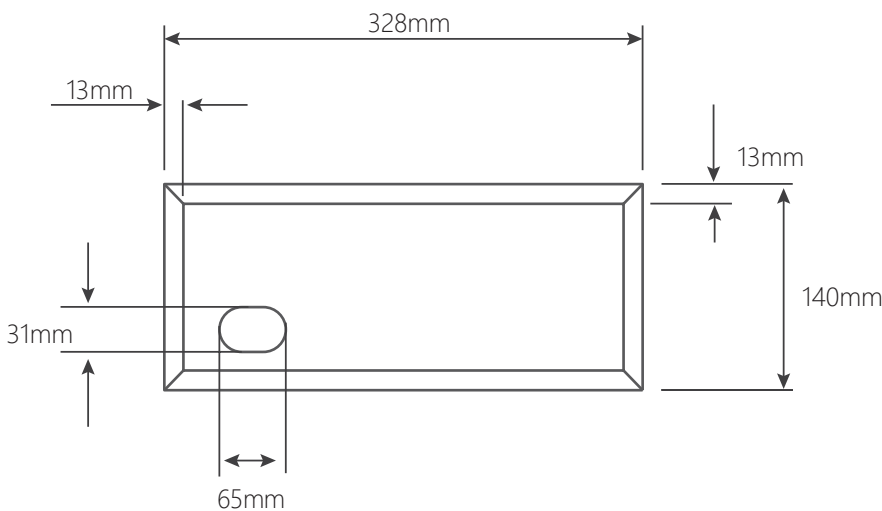

End view of Swift Box back plate SB2.
(Resined to back of SB1 prior to delivery).





CAST STONE **BAT & SWIFT BOX**

- The Forticrete Swift Box has been developed to be used in new build construction or renovation work where there is a requirement to provide a habitat for birds.
- The box is made of cast stone but is hollow in order to provide a haven for birds to nest in.
- The Swift Box illustrated is available from Forticrete's 'Stone in Stock' range without the swift motif, although bespoke boxes can be designed and made for any application. Swift motif and additional hole available as optional extras.

The Forticrete Swift box is not intended to open for inspection. There is no need to maintain or clean the nest boxes. Historically swifts use the same place for years and the cleaning of their nests by humans is not required. Other creatures such as moths will eat insects or detritus from the nest. Faecal matter is disposed of by the parents during their care of the chicks.

Never disturb the birds while nesting as it will encourage them to desert the nest and chicks. Swifts like company so a few boxes clustered together is ideal for them. They need to be at least 5 m from the ground just under adequately overhanging eaves so they are never in direct, strong sunlight. It is also not advisable to have the flight path obstructed by trees or have anything growing up the house near the boxes as predators can use it as a climbing frame.

Swifts drop into the air on leaving the nest box so placing it on a single storey building is inadvisable.

Ideal positions are North, North East or North West. Southerly facing walls can heat up too much in the summer even with the protection of the eaves.

The aperture for the swift box must always

be positioned near the bottom. Chicks will congregate around the aperture close to fledging, stretching their wings in readiness.

The unit can be mortared into the external leaf of a cavity wall and is sized at 327.5 x 140mm, a brick and a half long and two bricks high for bonding with the rest of the brickwork. The box is 137mm in depth plus a 13mm projecting chamfered face, and will extend into the cavity by 37mm. A cavity tray may be required if there is brickwork between box and eaves.

Refer to Technical Information Sheet 3 for

guidance on mortar. Generally mortar strength for Cast Stone Dressings should not exceed

designation (iii) proportional mix or strength class M4. Cracking can occur if mortar of a higher designation or strength is used.

Refer to Technical Information Sheet 5 for recommended associated materials and the Forticrete Sitework Guide.

Forticrete Swift Boxes are not classified as Non-Combustible and consequently cannot be used above 11m in the UK

Although the instructions contained in this publication and any other information published by Forticrete Ltd are believed to be accurate at the date of publication, they are strictly for guidance only and Forticrete Ltd accepts no liability in relation to their use or for any losses, howsoever caused. You are responsible for taking all reasonable steps to ensure your use of the product conforms to all applicable health and safety requirements from time to time. In doubt, please consult appropriately qualified persons. All products sold by Forticrete are sold subject to Forticrete Terms and Conditions of Sale, a copy of which is available on request.

