

## INSTALLATION GUIDE - HOW TO CONSTRUCT A STEPOC MOVEMENT JOINT (256mm)

Depending on the type of construction and wall lengths it may be necessary to incorporate movement joints to prevent potential cracking. Movement Joints are normally placed at maximum centres of 20m but at the structural engineer's discretion. This can be carried out very simply using standard components from the Stepoc range. Following this simple process will help to speed up the construction of the structure.

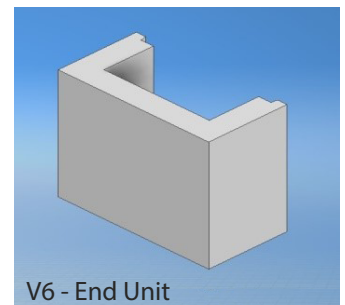
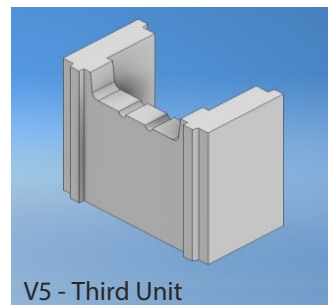
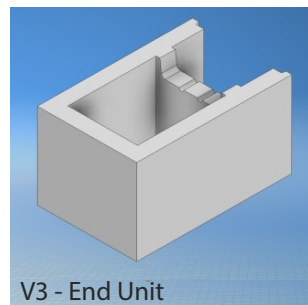
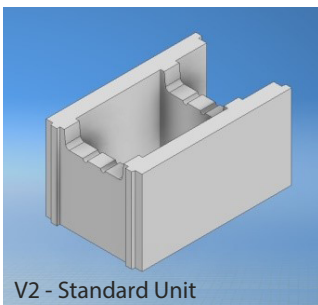

It is always recommended to construct corners and ends first and build away from these points. Any cuts can then be incorporated into the middle of the wall. Ensure vertical starter bars are in the correct position and at the correct centres (multiples of 133mm).

### Stepoc Movement Joint Construction

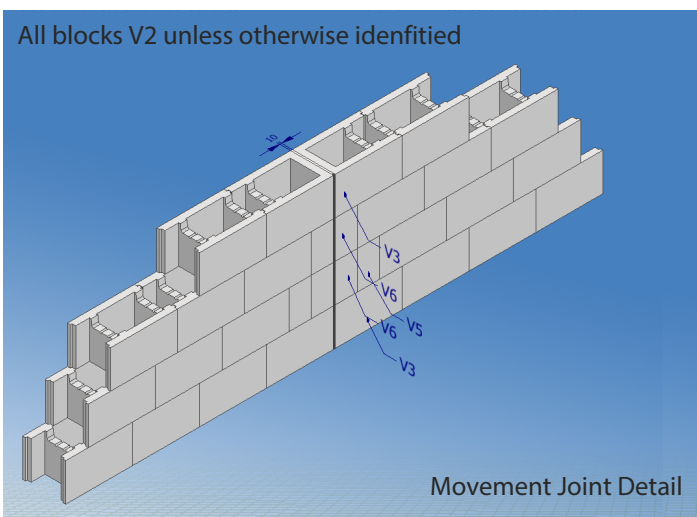

1. Movement Joints are created by constructing two Free Ends (IG5) back to back with a typical 10mm space.
2. The engineer's design will determine if the horizontal reinforcement should be continued across the joint.
3. The 10mm joint should be filled with flexible filler.
4. A mastic sealant is typically used at the front face.

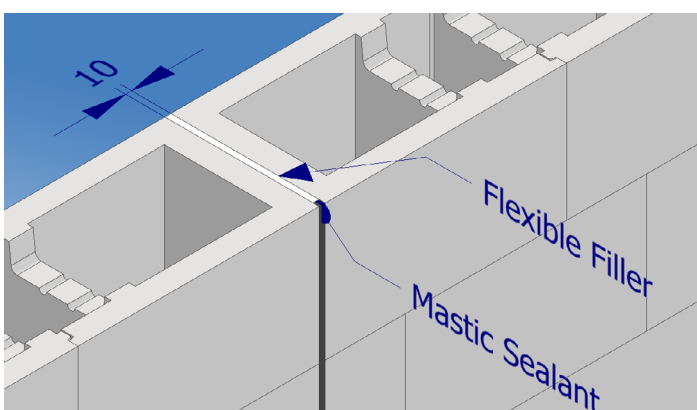

Mastic Sealant and Flexible filler to meet the specification of the Engineer and be determined by the individual use.

## **INSTALLATION GUIDE - HOW TO CONSTRUCT A STEPOC MOVEMENT JOINT (256mm)**

### **Additional Information**

256mm Stepoc can be constructed up to 10 courses high (2250mm) before filling with concrete. It is recommended to use some temporary propping at corners during the concreting process. Pour heights on site will be determined by particular circumstances but it is recommended that where multiple pours are used the concrete is left 75mm down from the top of the block to allow for a key with the subsequent pour.

Concrete Infill – 0.15m<sup>3</sup>/m<sup>2</sup>

Concrete specification to Structural Engineers design but no less than C32/40 with a slump category S4 and a maximum aggregate size of 10mm. Cover to vertical reinforcement should be minimum 40mm.