

WE ARE
Roofing and more



Ibstock
At the heart of building

SL8[®] ROOF TILES
THE INNOVATIVE LARGE FORMAT,
THIN LEADING EDGE ROOF TILE
WITH SUPERIOR COVERAGE

SL8
ROOF TILES

WE ARE at the heart of building.

We offer a diverse range of building products, solutions and expert technical and design services that enable our customers to create inspirational spaces and places.

Everything we do revolves around our valued customers and we continuously strive to exceed their expectations. We pride ourselves on leading for new, innovative and sustainable products and solutions, both for today and for a new era of building.

WE ARE at the heart of building. WE ARE Istock.



Bricks and Masonry

Our bricks and masonry range is truly comprehensive. Take the widest brick range in the UK and add in walling stone, architectural masonry, cast stone products and specials and you are sure to find a product for your project.

Facade Systems

With the establishment of Istock Futures, Istock is demonstrating a clear ambition to grow into the Facades sector. With Istock Telling GRC, Mechslip, Nexus and Genbrix we already have some fantastic solutions for this space.

Roofing

Our wide range of concrete roof tiles for the new build housing market, including the innovative SL8® and Gemini products, added to our high quality chimney options from Istock Kevington mean we've really got roofing covered.

Flooring and Lintels

A comprehensive range of flooring solutions and lintel products, including high fire rated options – with nationwide coverage delivered through our Supreme and Longley brands.

Staircases and Lift Shafts

Our bespoke high quality, Longley precast staircases and lift shafts are designed to meet your projects exact requirements.

Fencing and Landscaping

Istock offers a wide range of products for the fencing and landscaping sector – including high quality concrete fence posts from our Supreme brand or beautiful cast stone balustrades and pier caps from our Forticrete brand.

Retaining Walls

Whether it is a retaining wall solution to prepare a new site or for a major infrastructure scheme – our Anderton brand gives us the products and technical expertise to deliver.

Rail and Infrastructure

Istock Rail and Infrastructure combines rail troughs, signal bases, platform copers and other products for infrastructure from our Anderton range – all harnessing the latest in concrete technology to minimise embodied carbon without compromising performance.

Design and Technical Services

We are committed to providing the best possible design and technical support to our customers. From expert advice to a sector-leading training and CPD provision, Istock's range of design and technical services are especially configured to give architects and specifiers the access to the support they need at every stage on their project journey – from concept to build.



The next generation SL8[®] roof tile

Introducing the improved SL8 roof tile. Our large format roof tile that's up to 30% more sustainable* with a thin leading edge for impressive aesthetics.

A key element of the Istock ethos is looking at how we can improve our sustainability credentials without impacting the high-performance delivery of our portfolio of products.

Customer feedback is really important to us and we've listened to you! We appreciate how hard you strive to not only meet, but surpass sustainability standards.

Every product we manufacture is stringently trialled and tested within our purpose-built labs and is only introduced to the market after successfully completing our comprehensive evaluation process.

*Compared to the original SL8 tile figure calculated using industry average eCO₂

“

SL8 is a great product to work with. Its larger size tile means you don't have to transport as many to site and, with fewer tiles needed to cover the surface area of a roof, it helps save time and money.

Russel Whitney – Roof Plus

”

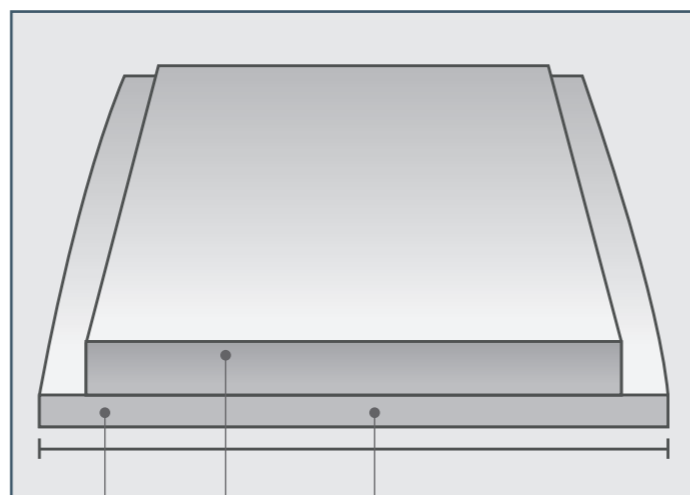

SL8[®]

STANDARD

SL8[®] TILES ARE 20% BIGGER IN WIDTH AND ALSO THINNER IN TERMS OF LEADING EDGE.

10 LARGE FORMAT TILES VS. 8 SL8[®] TILES

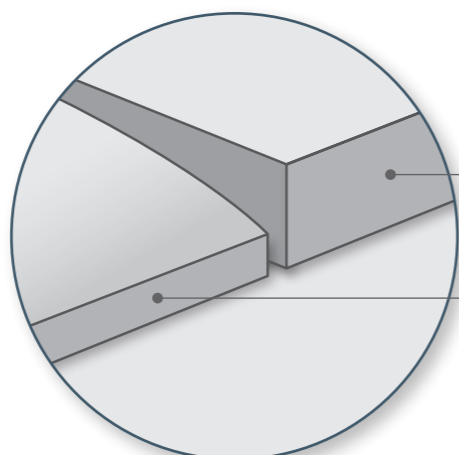
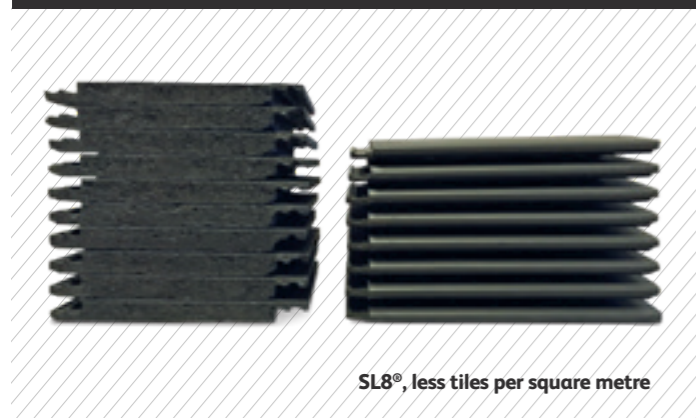

TYPICAL LEADING EDGE THICKNESS OF AN ALTERNATIVE LARGE FORMAT TILE

SL8[®] LEADING EDGE IS UP TO 50% THINNER THAN ALTERNATIVE LARGE FORMAT TILES

DID YOU KNOW.?

THIS TILE CONTAINS A **30% REDUCTION IN MATERIALS ECO₂** COMPARED TO ORIGINAL TILE MIX.

SL8®

The visual characteristics of natural slate with benefits that no other interlocking tile can match.

- Istock designed and manufactured fixings and fittings
- Full fixing specifications available from ibstock.co.uk
- A full range of maintenance free, mechanically fixed accessories and concrete fittings are available
- A thin leading edge for impressive aesthetics
- A wider format for a more traditional slate appearance
- Superior coverage at just 8 tiles per square metre
- 20% Reduction in the number of tiles used resulting in fewer tiles to handle and lay
- Easy to lay, with two nail holes for better fixing flexibility
- Packaging has been specifically designed to reduce damage and waste on-site
- Latest manufacturing technology ensures consistent quality

SL8® COLOUR RANGE:



RED

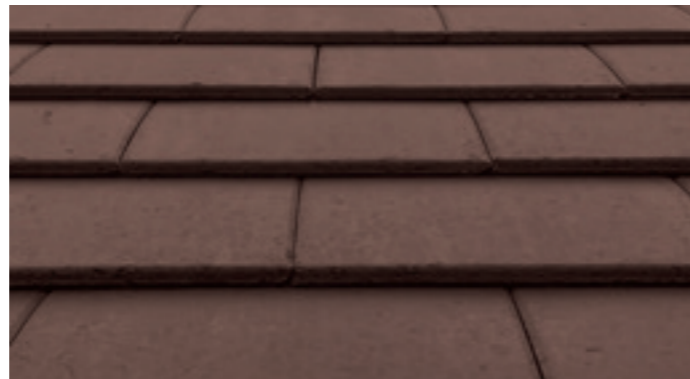

BROWN



SLATE GREY

*NOTE: Where an exact colour match is critical, you are advised to view actual tile samples.



Tile specifications

Reduce a buildings overall CO₂ emissions with the SL8[®] roof tile.

SL8[®] ROOF TILES

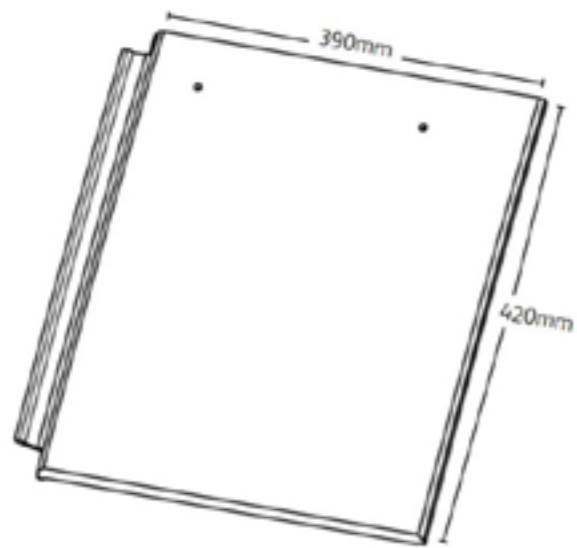

	Original SL8 [®]	Improved SL8 [®]
OVERALL LENGTH	420mm	420mm
HANGING LENGTH	396mm	396mm
OVERALL WIDTH	390mm	390mm
COVER WIDTH	362mm	362mm
MASS	5.4kg	5.4kg
PITCH	17.5° – 75°	17.5° – 75°
NAIL SIZE	45mm x 3.35mm	45mm x 3.35mm
17.5° – 22.5°		
HEADLAP	90mm min – 100mm max	100mm
BATTEN SPACING	330mm max – 320mm min	320mm
TILES PER M ²	8.37/m ² – 8.63/m ²	8.63/m ²
BATTERNS PER M ²	3.03lm – 3.13lm	3.13lm
MASS PER M ²	45.20kg – 46.62kg	46.62kg
22.5° – 75°		
HEADLAP	75mm min – 100mm max	75mm min – 100mm max
BATTEN SPACING	345mm max – 320mm min	345mm max – 320mm min
TILES PER M ²	8.01/m ² – 8.63/m ²	8.01/m ² – 8.63/m ²
BATTERNS PER M ²	2.90lm – 3.13lm	2.90lm – 3.13lm
MASS PER M ²	43.24kg – 46.62kg	43.24kg – 46.62kg
eCO ₂ PER TILE	1.03kg	0.77kg
eCO ₂ PER M ²	8.25kg	6.17kg

ASSOCIATED PRODUCTS

- Comprehensive range of mechanically fixed accessories
- Comprehensive range of ventilation systems to comply with BS 5250
- Tile clips

FIXING SPECIFICATIONS

- The exposure, location, and roof design will determine the tile fixing specification
- Fixing specifications in line with BS 5534 should be obtained prior to installation on-site from www.ibstock.co.uk/fixing-specification

WORKING PROCEDURES, SAFETY AND GENERAL PRECAUTIONS

Tiles should be fixed in accordance with BS 5534. Istock recommend that operatives installing all types of slates and tiles regard the products as being fragile as stated in BS 8000 Part 6.

During installation of the products, the correct setting out and working procedures should be employed to avoid walking directly on to products which have been fixed or on any completed area of a roof.

Should it be necessary to gain access via the roof where battens of adequate strength cannot be used as footholds, this should not be attempted without the use of adequate protection to the tiles or slates including the required number of crawling boards, ladders and cat ladders.

Please note that where there is a change of roof pitch, packing may be required between crawling boards, cat ladders, and the surface of the tiles or slates to avoid damage to the product.

Installers should note that Istock do not recommend the cutting of roof tiles or slates in-situ.

Other information can be obtained from the Health and Safety in Roof Work publication HSG33 and in the Working on Roofs publication INDG284.

Reference should also be made to the Istock technical literature and site specific Fixing Specification.



IBSTOCK

Leicester Road, Ibstock,
Leicestershire, LE67 6HS

www.ibstock.co.uk/roofing/sl8

T: 01530 261 999

E: roofing@ibstock.co.uk



Ibstock
At the heart of building