

Leviat®
A CRH COMPANY



Ibstock
At the heart of building

REACHING NEW HEIGHTS
WITH **NEXUS XI®**
BRICK-FACED SUPPORT SYSTEMS

Brick, the UK's favourite cladding material, is increasingly being used to deliver visually stunning buildings, with design elements that can sometimes appear to challenge normal structural principles.

Among these, and rising in popularity, are deep reveals and soffits where the main façade extends seamlessly to large areas of exposed brickwork forming overhangs and recesses.

These aesthetically pleasing features pose complex engineering challenges, as these areas of brick must be held in place ensuring the necessary supporting steelwork remains unseen.

To answer this challenge, Ibstock and Leviat, two of the UK's foremost innovators in brickwork manufacture and support, created **NEXUS XI**, a range of advanced lightweight solutions that make modern brick-faced soffits and lintels achievable and easy to install.

CONTENTS

A PARTNERSHIP IN PRECISION LEVIAT AND IBSTOCK

04

NEXUS XI BRICK-FACED SOFFIT AND LINTEL SYSTEMS

06

NEXUS XI BRICK-FACED SOFFIT SUPPORT SYSTEMS

08

NEXUS XI BRICK-FACED LINTELS

10

HOW TO SPECIFY NEXUS XI

12

NEXUS XI BRICK-FACED SOFFIT SYSTEMS – INSTALLATION GUIDE

14

NEXUS XI BRICK-FACED LINTELS – INSTALLATION GUIDE

15

PRODUCT REFERENCES CASE STUDIES

16

IBSTOCK AT THE HEART OF BUILDING

30

LEVIAT INNOVATIVE CONSTRUCTION SOLUTIONS

32

One of the major issues facing our industry today is fire safety, and companies such as ours, industry organisations and legislators are continually looking to develop new, innovative solutions to make buildings safer.

At Ibstock and Leviat we want to do 'the right thing' – our sense of responsibility stretches not just to our customers but to all those who encounter our work.

So when faced with challenges such as major changes in legislation, we see this not as an obstacle to overcome but as an opportunity to improve our product offering.

Recent changes to building regulations in UK home nations require all residential buildings over 11m to use façade materials that are either A1 non-combustible, or A2 limited combustibility. Consultation with the current regulations in the relevant country is essential. **NEXUS XI** has a reaction to fire classification of A2-s1, d0.

It was these changes that led us to develop our world leading mechanically-fixed **NEXUS XI** soffit and lintel solutions.

Illustration of Approved Document B update

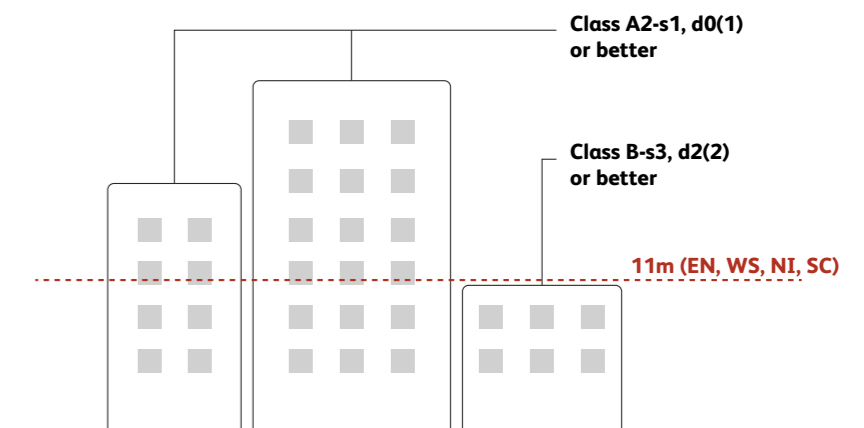

EN – England, WS – Wales, NI – Northern Ireland, SC – Scotland

A PARTNERSHIP IN PRECISION

The range of **NEXUS XI** brick-faced support systems is a joint venture from Leviat and Ibstock. **LEVIAT** is a world leader in connecting, fixing, lifting and anchoring technology whilst **IBSTOCK** manufactures the largest brick range in the UK.

Together, we bring our technical and manufacturing expertise to provide you with lintels and soffit systems that realise your architectural vision, by helping to bring depth and dynamism to your project.

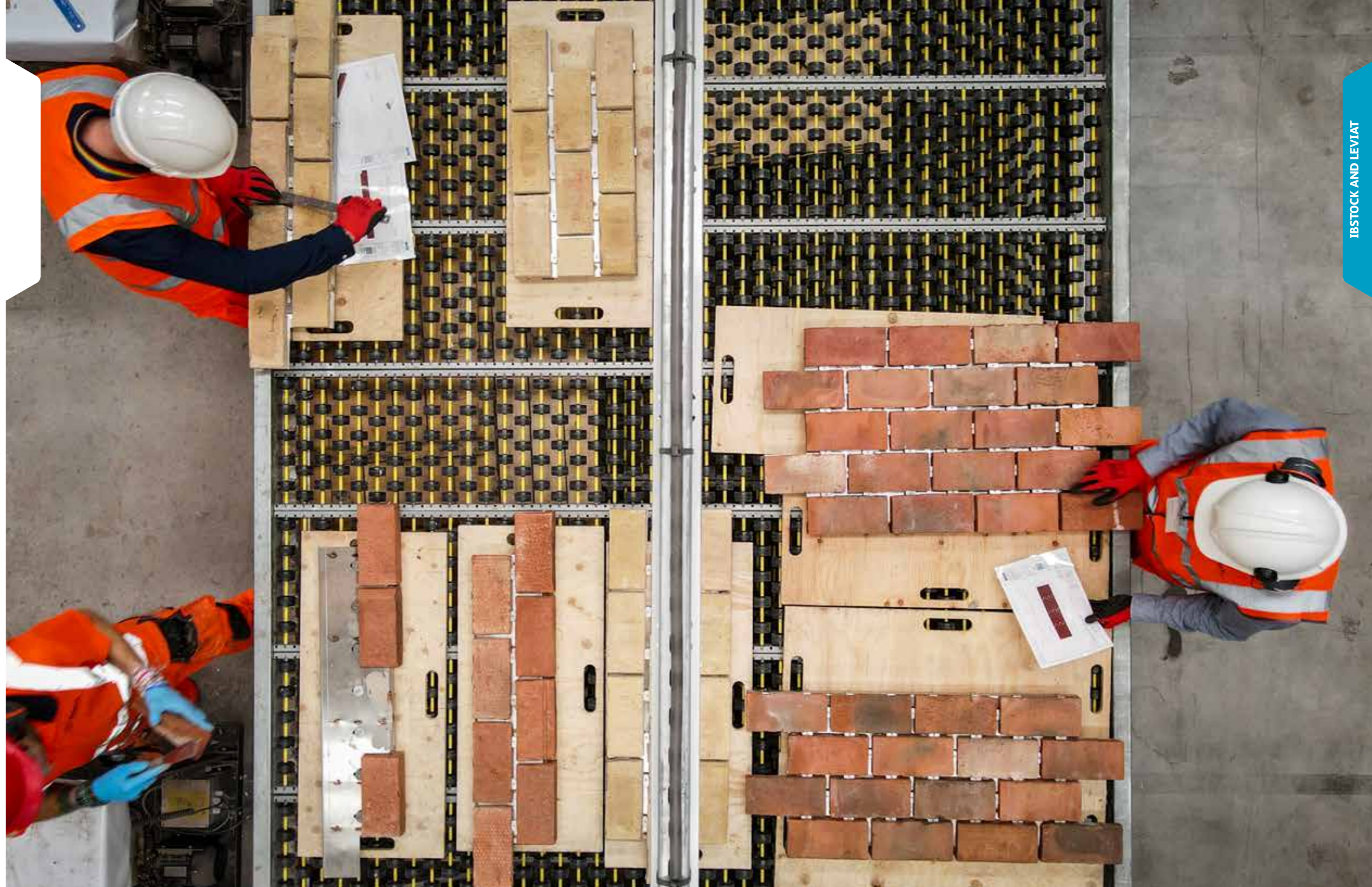

WITH **NEXUS XI**[®] YOU GET DOUBLE



Double the expertise – combining the expertise of two of the UK's leading construction specialists



Double the technical support – technical experts in both fields



Double the knowledge – more than 150 years' experience in high integrity brickwork support and brick engineering



Double the commitment – two companies with a history of innovation, quality and excellent customer support

NEXUS XI® BRICK-FACED SOFFIT AND LINTEL SYSTEMS

NEXUS XI provides an innovative, mechanically fixed suspended brickwork soffit and lintel solution.

NEXUS XI has a Reaction to Fire classification of A2-s-1,d0 as stated in the BBA certificate, meaning it can be specified and installed with confidence on high-rise buildings over 11 meters, in compliance with building regulations in all UK home nations.

The system comprises a stainless steel soffit tray or lintel with an A2 rated chemical bond to reduce vibrational forces between the brick slip and stainless steel.

Alongside its key safety credentials, **NEXUS XI** packs a number of other primary benefits, including:

- ✓ Quicker to install – no mechanical lifting
- ✓ Lighter than precast alternatives
- ✓ Simply lift into position
- ✓ Designed and prefabricated to fit any size or shape soffit
- ✓ Any brick type and bond pattern can be accommodated
- ✓ Increase your project's pre-manufactured value with this offsite solution
- ✓ Suitable for buildings over 11m high
- ✓ Two part system allows full adjustment for perfect alignment
- ✓ BBA Certified for any building height



For ultimate durability, **NEXUS XI** has been engineered as a mechanical fix solution. This means that each individual brick on the suspended brickwork system is held in place using a combination of innovative fixing methods.



MECHANICAL FIX SOLUTION

100% stainless steel mechanical fix solution, fixes straight into stainless steel tray. Proven durability and maximum corrosion resistance.

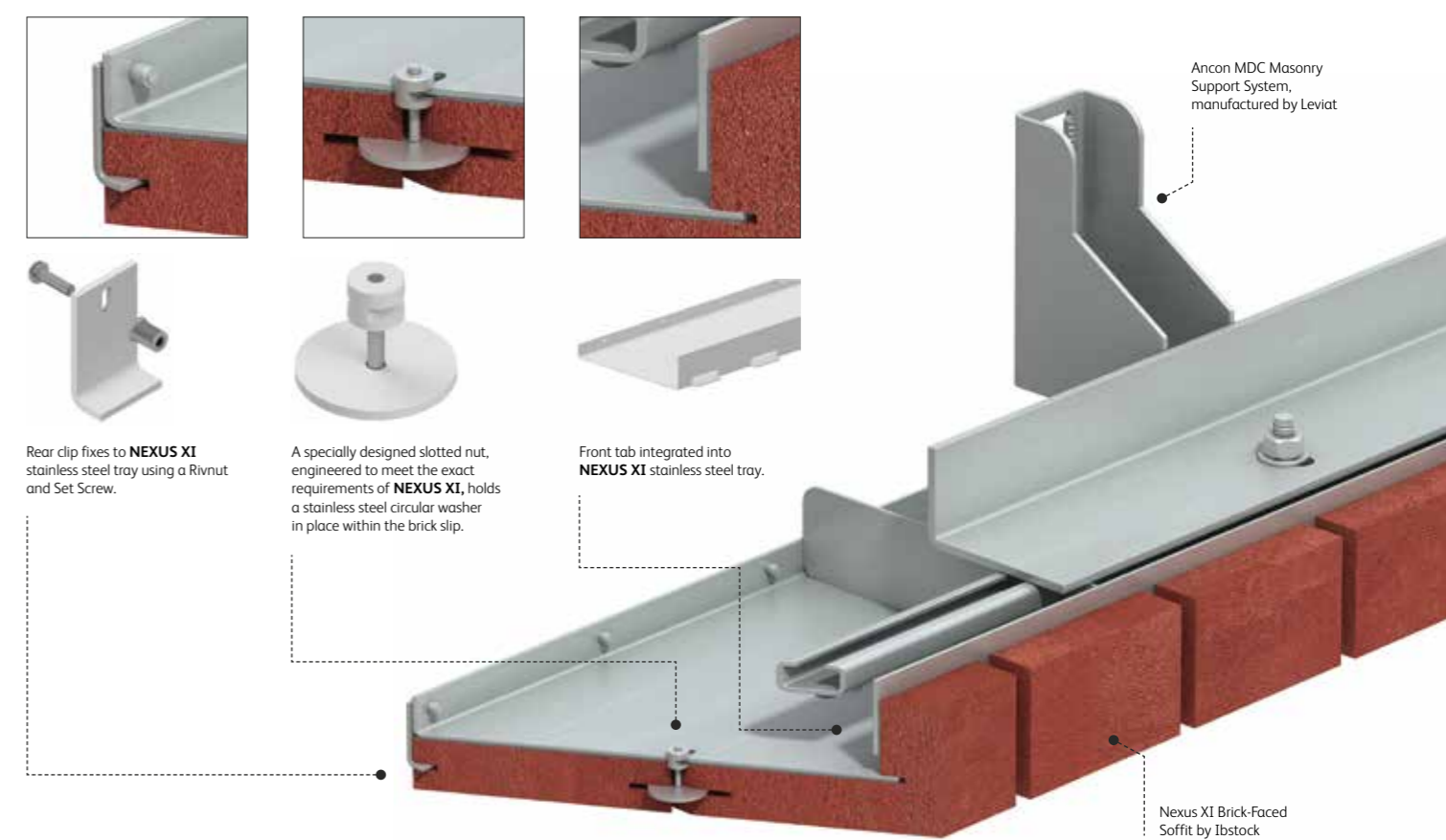

NEXUS XI® BRICK-FACED SOFFIT SUPPORT SYSTEMS

The **NEXUS XI** range of brick-faced soffit systems comprises both standard and bespoke solutions to enable the creation of deep reveals and soffits. Typical solutions are shown below. Bespoke solutions including other brick arrangements can be designed to suit project requirements. Please contact us for more information.



- ✓ Two-part system allows full adjustment for perfect alignment
- ✓ Lightweight design – simply bolt into position
- ✓ Designed and prefabricated to fit any size or shape soffit
- ✓ Any brick type and bond pattern can be accommodated

65 x 215mm WITH HEADER BOND

A simple, effective means of creating feature header details and reveals, with the header bond differentiating the soffit from the main façade.

Brick slip facings can be manufactured from the same batch as the main brickwork to present a perfect colour and texture match.

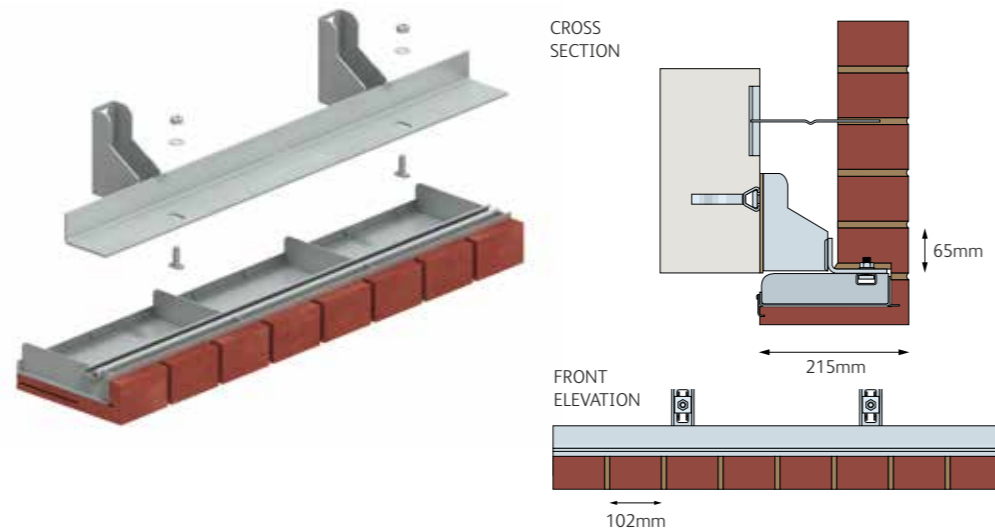

65 x 440 x 65mm WITH STRETCHER BOND

Used to create double-faced soffit details providing continuity to the main brickwork façade.

Each soffit unit is designed to interlock with the adjacent unit providing a flawless transition once the brickwork is pointed.

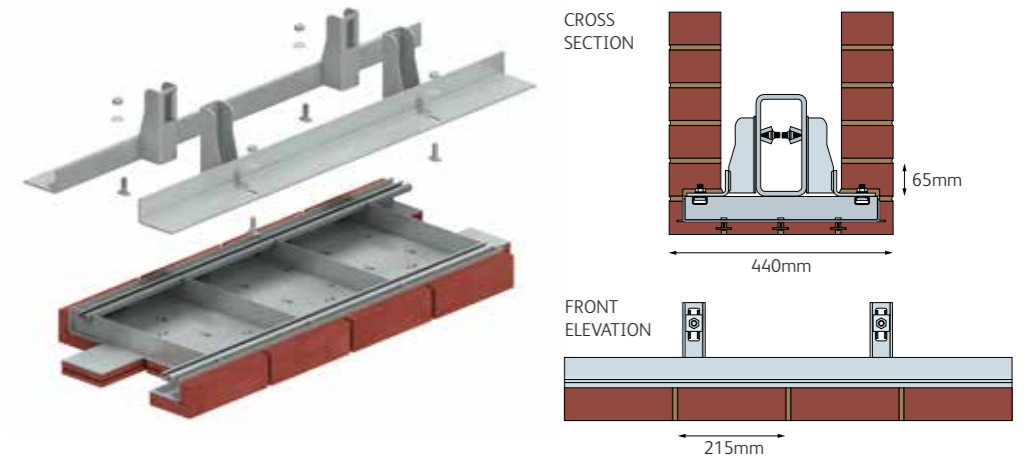

215 x 102mm WITH SOLDIER BOND

A simple, effective means of creating feature soldier course details above door and window openings.

Brick slip facings can be manufactured from the same batch as the main brickwork to present a perfect colour and texture match for a flawless transition.

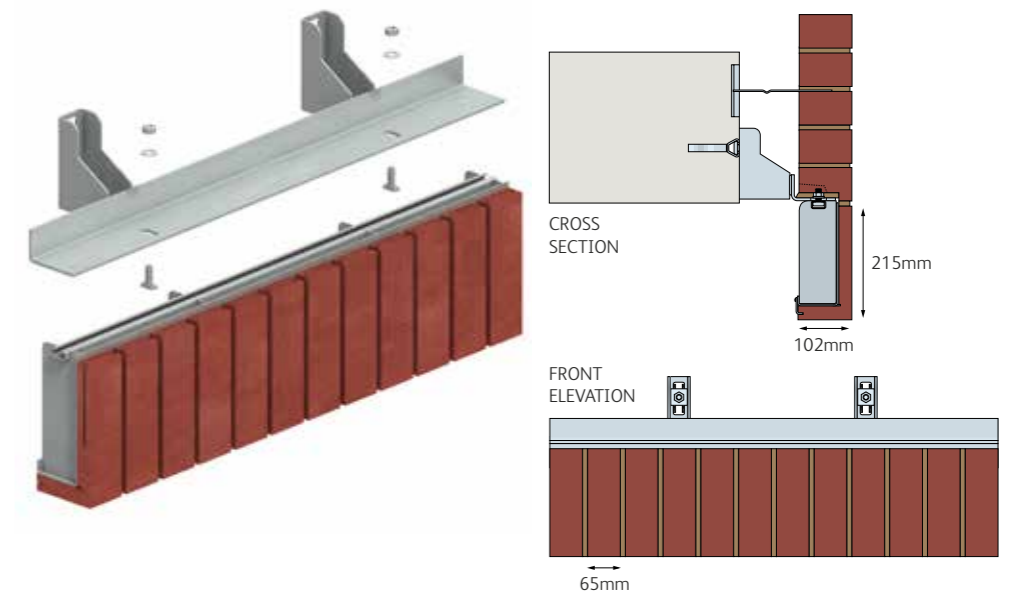

65 x 665 x 65mm WITH STRETCHER BOND

Used to create double-sided soffit details providing continuity to the main brickwork façade.

Each soffit unit is designed to interlock with the adjacent unit providing a flawless transition once the brickwork is pointed.

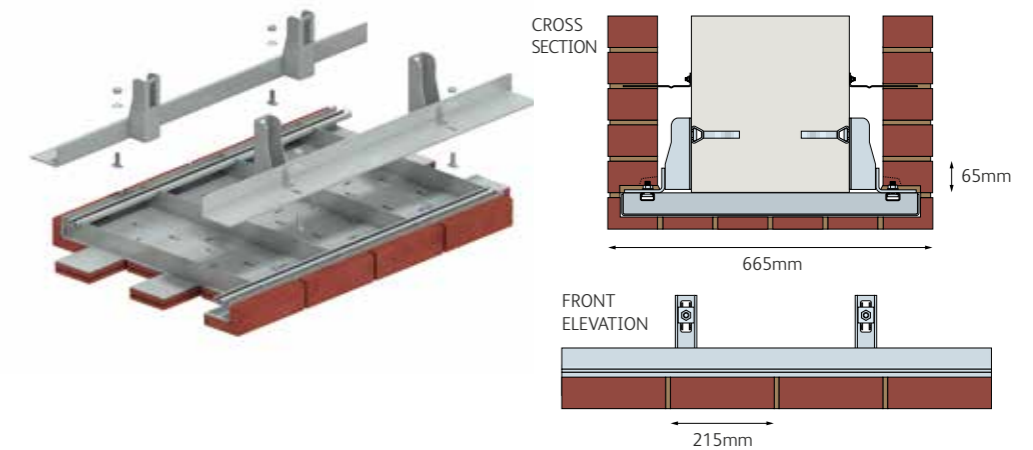



65 x 215mm
WITH STRETCHER BOND

Used to create stretcher bond header details and maintain the brickwork bond over openings.

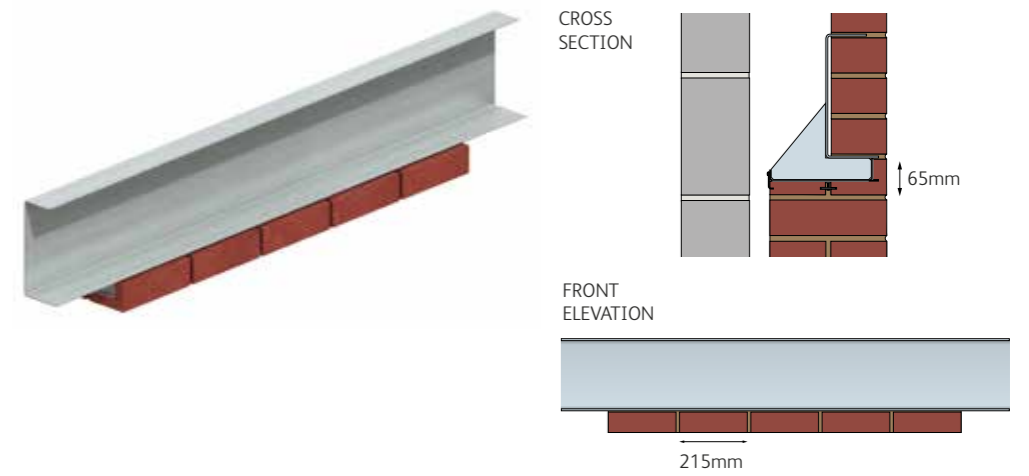

215 x 215mm
WITH SOLDIER BOND

Used to create soldier course header details providing a simple, effective brickwork feature.

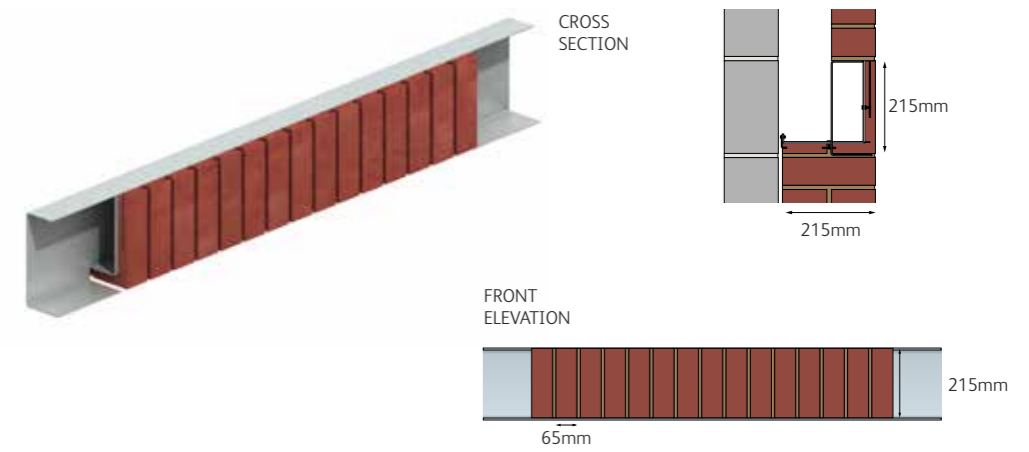

NEXUS XI®
BRICK-FACED LINTELS

NEXUS XI brick-faced lintels are designed to carry a single leaf of a cavity wall. Prefabricated from stainless steel for maximum corrosion protection, they offer a quick and simple way of creating deep soffits above window and door openings.

They are ideal where speed is important – the permanently bonded brick slips, applied offsite, are manufactured from the same batch as the main brickwork providing a seamless blend meaning no compromise on quality or appearance. The lightweight design means shorter lengths can be lifted into place by hand, saving time on site.

- ✓ Manufactured offsite
- ✓ Lightweight, one-piece design – simply lift into place
- ✓ Designed to suit a variety of spans and loads
- ✓ Variable face and soffit depths available

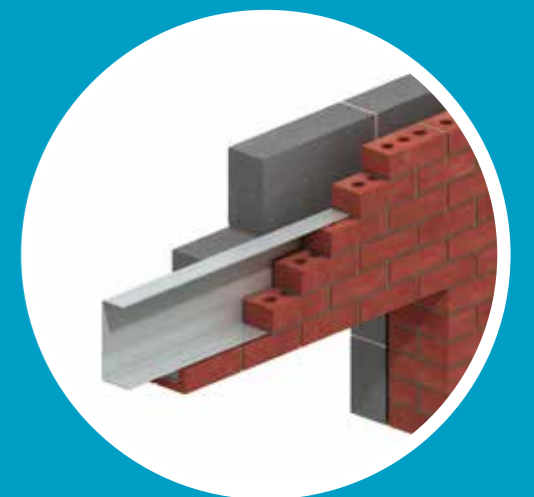

HOW TO SPECIFY NEXUS XI®

To discuss your **Nexus XI®** requirements, simply call us on **0800 634 5500** or email **nexus@ibstock.co.uk**

Technical and Design Support



DESIGN ADVICE

An integral part of Ibstock's service is a full 3D CAD design and structural engineering service. This ensures that we can turn your design concepts into quality, cost effective, easy to build structural elements. Contact us with your requirements.



NBS SPECIFICATION CLAUSES

Product information is listed within NBS Chorus, the industry standard specification software used by architects, building surveyors and other construction industry professionals. This means that technical information for our products is available to NBS subscribers, in NBS format, at the relevant point in the specification.



CPD SEMINARS

The Nexus XI CPD seminar is delivered by Leviat technical representatives and Ibstock design advisors who have considerable experience of these systems and in answering questions from both specifiers and contractors.

In addition, Leviat offers a number of other CPD seminars covering Facade Support & Restraint solutions. Call 0114 275 5224 or email cpd.uk@leviat.com for more information.



PROJECT MANAGEMENT

We will work closely with you to coordinate the design, manufacture and delivery of the complete system to suit site progress.



CONTRACT SUPPORT

Both Leviat and Ibstock technical and design staff are available to attend office and site meetings to provide assistance at any stage in the process including pre-tender and pre-contract.



MASONRY SUPPORT

For technical and design advice on Masonry Support Systems please contact the Leviat Technical Team on 0114 275 5224 or email tech.ancon.uk@leviat.com.

Specification Clauses



ANCON MDC/NX BRACKET/ANGLE SUPPORT SYSTEM

Ancon MDC systems are tailored to suit each project. Each system is based on the cavity size at the support and the unfactored masonry load to be carried. An economical configuration of channel, bracket and angle will be designed.

Specify Ancon MDC/cavity/unfactored masonry load/NX e.g. MDC/200/12/NX.

Against this a system will be designed to suit a 200mm cavity and carry 12.0kN/m of masonry (unfactored), and would be complete with fixing points to suit an underslung NEXUS XI unit below the angle.

IBSTOCK NEXUS XI SOFFIT UNIT

Engineered brick or masonry slips mechanically fixed to a grade 1.4301 stainless steel unit. The size of the unit and bond pattern of the engineered brick slips are tailored to suit project requirements. Specify face and soffit dimensions and bond pattern to be included on the NEXUS XI unit.

IBSTOCK NEXUS XI LINTEL

NEXUS XI Lintels are designed to carry a single leaf of a cavity wall. Tailored to suit each project, specification is based on the span of the opening and load to be supported. Engineered brick or masonry slips are mechanically fixed to the grade 1.4301 stainless steel lintel. Specify opening size, face and soffit dimensions and load to be supported.

Product Specifications



STEELWORK

Stainless steel grade 1.4301, manufactured in a BS EN 1090-1 approved factory and UKCA / CE marked.

FIXINGS

Stainless steel grade 1.4301 slotted nuts, set screws, circular washers and Rivnuts.

BRICK SLIPS

25mm thick and manufactured in accordance with BS 4729 and cut from a full brick that is manufactured to BS EN 771-1 and UKCA marked.

BEDDING AGENT

Brick-Fix 31 A2 Firebond is retained in the system to reduce vibration between the stainless steel and brick slip only and does not hold a structural function in connecting the brick slips to the units. The overall units holds a fire rating of A2-s1,d0.

NEXUS XI has been tested by Lucideon for long term durability, certified as fit for purpose across multiple factors in a BBA Agreement certificate and accepted by NHBC for use on projects.

NEXUS XI® BRICK-FACED SOFFIT AND LINTEL SYSTEMS INSTALLATION GUIDE

Brick-Faced Soffit Systems

NEXUS XI soffit units are designed to be simply lifted and bolted to pre-installed Ancon MDC brick support angles. Each soffit unit comprises a stainless steel carrier with integrated Ancon channel to simplify installation to the brick support angle.



SOFFIT INSTALLATION GUIDE

This video highlights the benefits of the system and demonstrates how quick and easy it is to install. [Scan the QR code to watch the video.](#)



LINTEL INSTALLATION GUIDE

This video highlights the benefits of the system and demonstrates how quick and easy it is to install. [Scan the QR code to watch the video.](#)



STEP 1

Install MDC **NEXUS XI** masonry support system in line with Ancon MDC Masonry Support Systems Installation Guide to the point where the fixing bolts are fully torqued.



STEP 3

Add washer and nut to bolts and finger tighten onto angle. Ensure the T-head bolt is fully turned and engaged in the channel.

If the angle is correctly levelled there should be no need to add shims between the soffit unit and the angle. If however shimming is required then they should be added now. Horseshoe shims must 'surround' the bolt and extend for the full contact area between soffit unit and angle. They must NOT be placed in any other location other than around the bolt as this will lead to deformation of the angle when the bolts are torqued.

NOTE: The bolt should have a minimum of two threads visible above the nut, if shimming has reduced this clearance, longer bolts will be required.



STEP 2

Place the **NEXUS XI** soffit unit's T-head bolts in the 28/15 channel to align with the slots in the angle and lift the soffit unit to the underside of the masonry support angle.

The soffit unit should continue to be supported through steps 3 and 4.



STEP 4

Once satisfied with the line and level of the soffit unit, the bolts should be torqued to 20Nm.

The support to the soffit unit can now be removed.



STEP 5

Brickwork should then continue on the masonry support system in line with normal bricklaying practice and the Ancon MDC Masonry Support Systems Installation Guide.

NOTE: The movement joint in soffit hung details is below the soffit unit. Compressible material should be placed below the soffit unit and NOT between the angle and soffit unit.

STEP 6

Point soffit unit to match main brickwork.

STEP 1

Raise the inner and outer leaves simultaneously to avoid excessive eccentricity of loading, with a maximum height difference of 225mm. Masonry should be laid on a full mortar bed and all perpendicular joints should be fully filled.

Allow the mortar to cure before applying floor or roof loads.



STEP 2

Lintels must be suitably propped during construction at approximately 1 metre centres. On small openings, a central prop can be used. A board should be used between lintel and prop to protect the finished surface and spread the load evenly.



STEP 3

Lintels should be installed with at least 150mm end bearing and be fully bedded on bricklaying mortar.

Ensure lintel is level along the length and width.



STEP 4

The NHBC, PD6697 recommends a damp-proof course (DPC) or cavity tray is installed over all openings in external cavity walls.



STEP 5

Weep-holes should be provided in the outer leaf above the lintel to drain moisture from the cavity. A minimum of two weep-holes should be provided per lintel. For fair-faced masonry, weep-holes should be provided at centres not greater than 450mm.



STEP 6

Precautions must be taken to prevent mortar dropping through the cavity onto the lintel and obstructing the weep-holes.

STEP 7

Brick slips should be pointed using the same mortar as the rest of the brickwork, but only after the full load has been applied to the lintel.



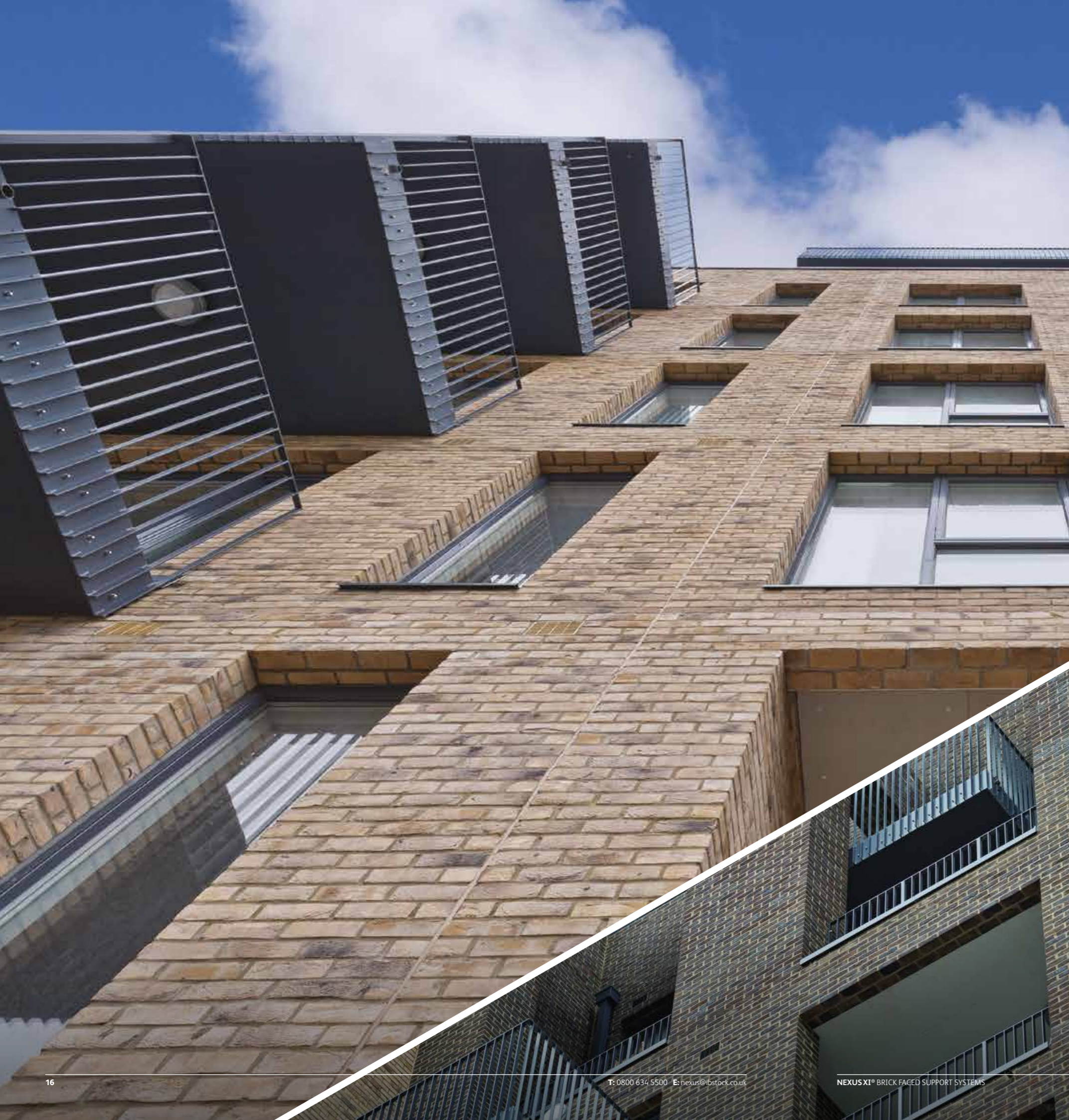

CASE STUDY

BOW RIVER VILLAGE, LONDON

PRODUCTS

NEXUS XI® brick-faced soffit units and lintels used at door and window heads.



CASE STUDY

SILCHESTER ESTATE, KENSINGTON, LONDON

PRODUCTS

NEXUS XI® brick-faced soffit units and lintels supplied to window heads and entrance.

CASE STUDY





CASE STUDY

MUIRFIELD COMMUNITY CENTRE, SCOTLAND

PRODUCTS

235 custom-designed **NEXUS XI**® window head and colonnade soffits and lintel units.



CASE STUDY

CASE STUDY

GREAT EASTERN QUAYS, LONDON

PRODUCTS

2,300 linear metres of NEXUS XI® lightweight brick-faced soffit units.





CASE STUDY

BEAK STREET, LONDON

PRODUCTS

Bespoke glazed brick-clad soffit units.

CASE STUDY

STONEBRIDGE

PRODUCTS

A combination of brick-faced lintels and underslung soffits.





CASE STUDY

PALL MALL, LIVERPOOL

PRODUCTS

NEXUS XI® 215mm soldier course and 665mm deep soffits.



WE ARE at the heart of building.

We offer a diverse range of building products, solutions and expert technical and design services that enable our customers to create inspirational spaces and places.

Everything we do revolves around our valued customers and we continuously strive to exceed their expectations. We pride ourselves on leading for new, innovative and sustainable products and solutions, both for today and for a new era of building.

WE ARE at the heart of building. WE ARE Ibstock.



Bricks and Masonry

Our bricks and masonry range is truly comprehensive. Take the widest brick range in the UK and add in walling stone, architectural masonry, cast stone products and specials and you are sure to find a product for your project.

Facade Systems

With the establishment of Ibstock Futures, Ibstock is demonstrating a clear ambition to grow into the Facades sector. With Ibstock Telling GRC, Mechslip, Nexus and Genbrix we already have some fantastic solutions for this space.

Roofing

Our wide range of concrete roof tiles for the new build housing market, including the innovative SL8 and Gemini products, are backed up by a comprehensive range of compatible detailing and ventilation accessories.

Flooring and Lintels

A comprehensive range of flooring solutions and lintel products, including high fire rated options – with nationwide coverage delivered through our Supreme, Longley and Coltman brands.

Staircases and Lift Shafts

Our bespoke high quality, Longley precast staircases and lift shafts are designed to meet your projects exact requirements.

Fencing and Landscaping

Ibstock offers a wide range of products for the fencing and landscaping sector – including high quality concrete fence posts from our Supreme brand or beautiful cast stone balustrades and pier caps from our Forticrete brand.

Retaining Walls

Whether it is a retaining wall solution to prepare a new site or for a major infrastructure scheme – our Anderton brand gives us the products and technical expertise to deliver.

Rail and Infrastructure

Ibstock Rail and Infrastructure combines rail troughs, signal bases, platform copers and other products for infrastructure from our Anderton range – all harnessing the latest in concrete technology to minimise embodied carbon without compromising performance.

Design and Technical Services

We are committed to providing the best possible design and technical support to our customers. From expert advice to a sector-leading training and CPD provision, Ibstock's range of design and technical services are especially configured to give architects and specifiers the access to the support they need at every stage on their project journey – from concept to build.



We imagine, model and make engineered products and innovative construction solutions that help turn architectural visions into reality and enable our construction partners to build better, safer, stronger and faster.

Leviat is a world leader in connecting, fixing, lifting and anchoring technology.

From the build of new schools, hospitals, homes and infrastructure, to the repair and maintenance of heritage structures, our engineering skills are making a difference around the world.

We provide technical design assistance at every stage of a project, from initial planning to installation and beyond.

Our technical support services range from simple product selection through to the development of a fully customised project-specific design solution.

Every promise we make locally, has the commitment and dedication of our global team behind it. We employ almost 3,000 people at 60 locations across North America, Europe and Asia-Pacific, providing an agile and responsive service worldwide.

Leviat, a CRH company, is part of the world's leading building materials business.

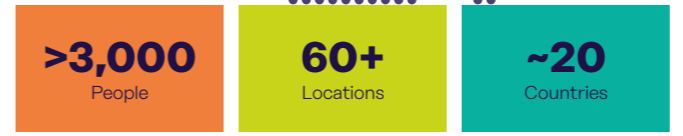
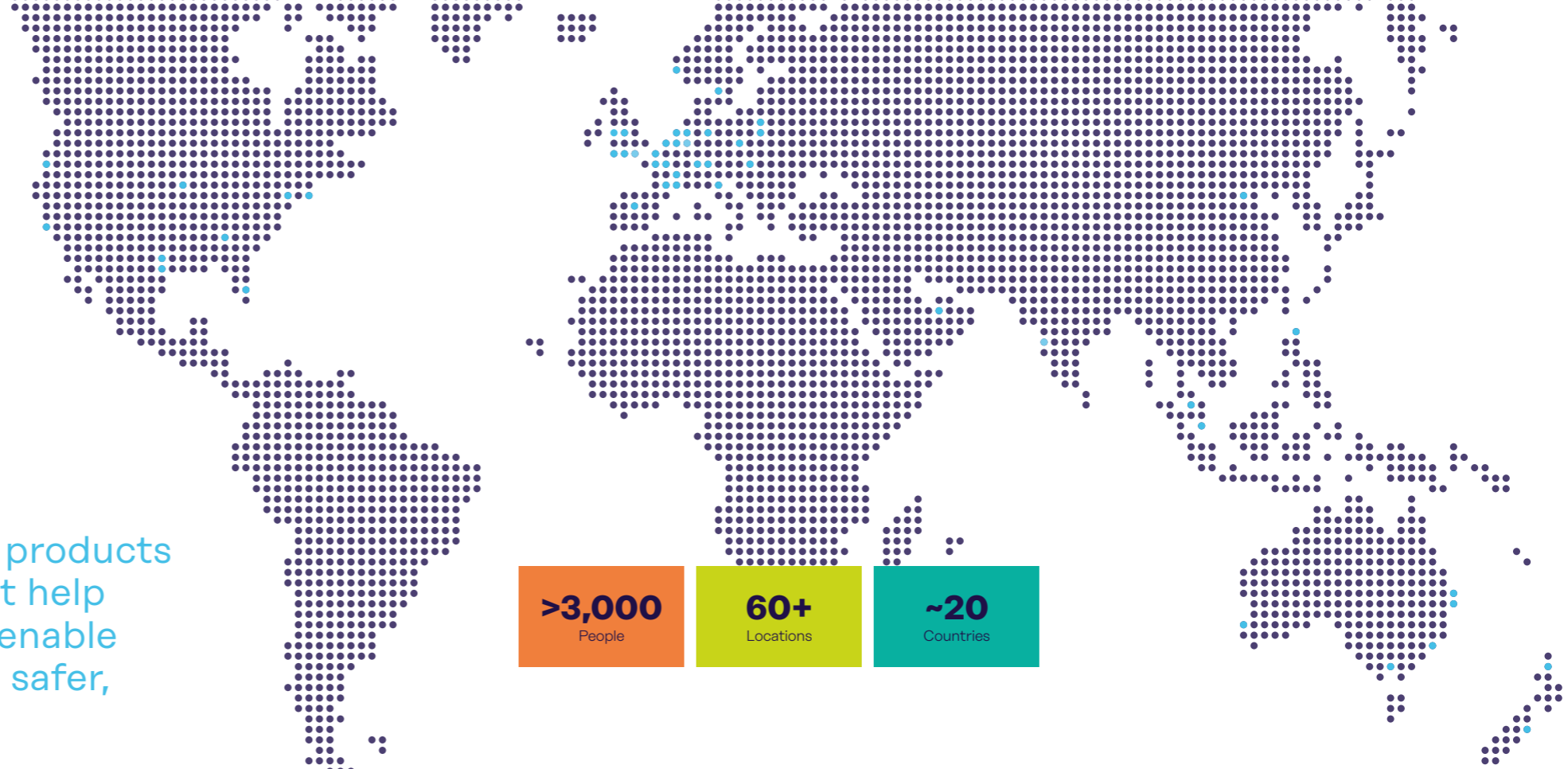

Our areas of expertise:

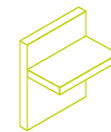

Structural Connections

Systems to form robust, efficient connections, and continuity of concrete reinforcement as necessary, between walls, slabs, columns, beams and balconies, providing structural integrity as well as enhanced thermal and acoustic performance.



Lifting & Bracing

Systems for the safe and efficient transportation, lifting and temporary bracing of cast concrete elements and tilt-up panels before permanent structural connections are made.

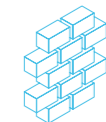

Façade Support & Restraint

Systems for the safe and thermally-efficient fixing of the external building envelope, including brick and natural stone, insulated sandwich panels, curtain walling and suspended concrete façades, and also the repair and strengthening of existing masonry installations.

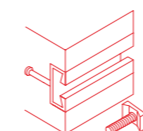

Anchoring & Fixing

Systems for fixing secondary fixtures to concrete, including anchor channels, bolts and inserts; also tension rod systems for roofs and canopies.



Formwork & Site Accessories

Non-structural accessories that complement our engineered solutions and help keep your construction environment operating safely and efficiently, including moulds for casting standard and special concrete elements and construction essentials such as reinforcing bar spacers.

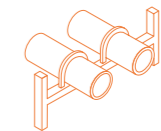

Industrial Technology

Mounting channels, pipe clamps and other versatile framing systems that provide safe fixing in a wide range of industrial applications.

Leviat product ranges:

Ancon | Ashwanden | Connolly | Halfen | Helifix | Isedio | Meadow Burke | Modersohn | Moment | Plaka | Scaldex | Thermomass

To discuss your **Nexus XI**[®] requirements,
simply call us on **0800 634 5500** or email
nexus@ibstock.co.uk

Ibstock

T: 0800 634 5500

www.ibstock.co.uk/nexus

Leviat Masonry Support Products

T: 0114 275 5224

www.ancon.co.uk/nexus

