

**WE ARE**  
Masonry and more.



**Ibstock**  
At the heart of building

ARCHITECTURAL  
MASONRY RANGE



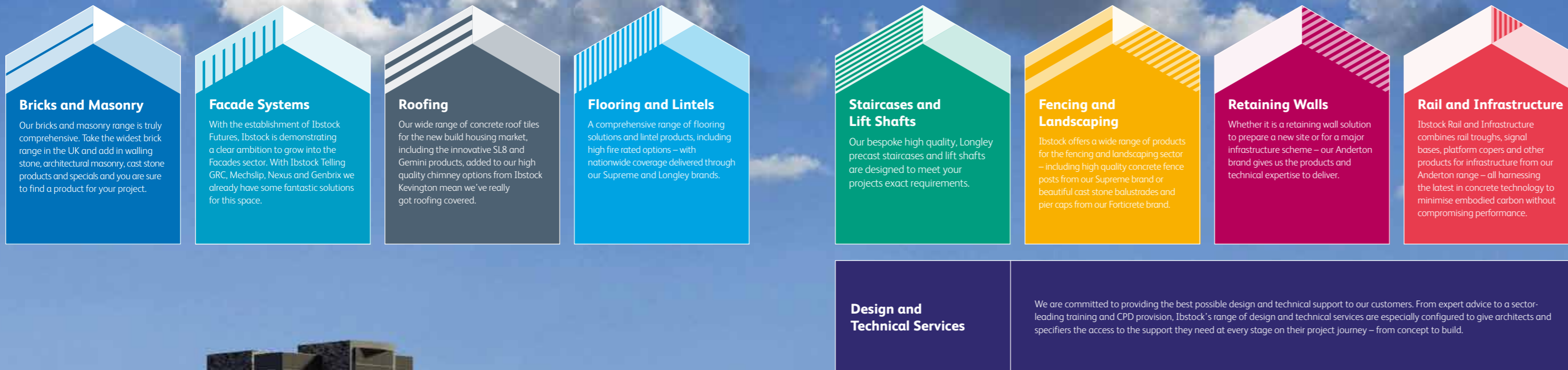

**WE ARE**  
at the heart of building.

We offer a diverse range of building products, solutions and expert technical and design services that enable our customers to create inspirational spaces and places.

Everything we do revolves around our valued customers and we continuously strive to exceed their expectations. We pride ourselves on leading for new, innovative and sustainable products and solutions, both for today and for a new era of building.

**WE ARE at the heart of building. WE ARE Ibstock.**

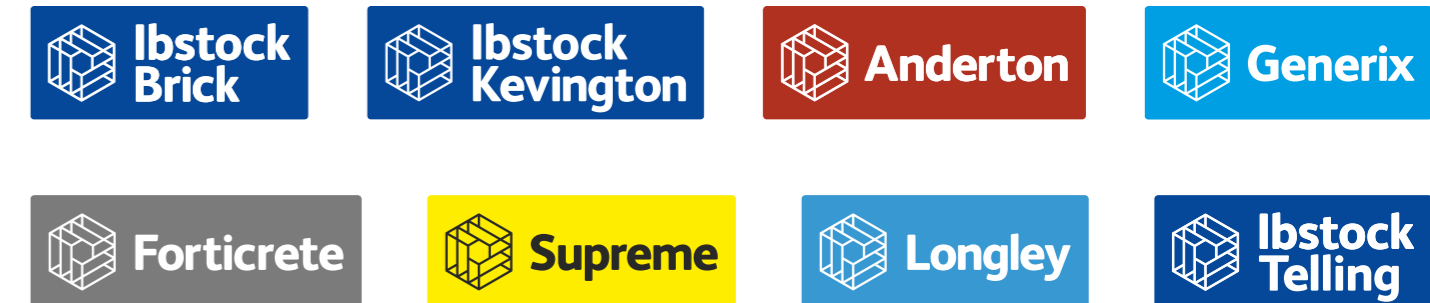

[www.ibstock.co.uk](http://www.ibstock.co.uk)



# OUR SUSTAINABILITY COMMITMENT

Our guiding purpose is to build a better world by being at the heart of building. To achieve this, we have developed an Environmental, Social and Governance Strategy, our ESG Strategy 2030, simplifying the way we articulate our goals and ambitions.

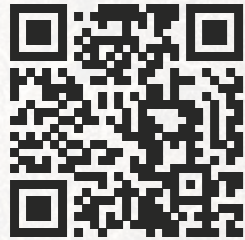

Please scan the QR code to find out more.

- Carbon reduction**  
Reduce absolute Carbon (Scope 1 and 2) by 40 % against 2019 baseline.
- Water efficiency**  
Reduce mains water use by 25 % per tonne of production against a 2019 baseline.
- Biodiversity net gain**  
Achieve Biodiversity Net Gain across our estate using Biodiversity Metric 2.0.
- Product innovation**  
Achieve 20 % sales turnover from new products and solutions that deliver customer value and improved sustainability.
- Dematerialisation**  
Reduce raw materials consumption with a focus on plastics, secondary aggregate and cementitious replacements.
- Circular economy**  
Embed circular economy principles into the business, prioritising zero waste and driving demand for secondary materials markets.



- Health, safety & wellbeing**  
Ensure all our employees can be at their best more of the time through our health, safety and wellbeing strategies.
- Inspiring futures**  
Provide development and growth for all, with every employee developing their skills annually and 10 % in Earn and Learn positions.
- Employee experience**  
Increase female senior leadership representation to 40 % by 2027 as part of our proactive approach to diversity and inclusion.

**2022** Accelerating change

**2030** Scaling solutions

**2040**

**2050**

SCOPE 1 AND 2

- Energy from alternative sources
- 100% of Mobile Plant and company cars hybrid and/or electric
- Biodiversity Net Gain
- Commissioning of Atlas factory
- Commissioning of Nostell Brick slips systems factory
- Major capital investments

- Energy from alternative sources
- Expansion of diversified product portfolio
- Core products = low carbon products
- Circularity embedded
- Carbon capture use and storage scaled
- Balance any remaining emissions that cannot be eliminated with natural or technical solutions

## NET ZERO FOR SCOPE 1 AND 2 EMISSIONS BY 2040



SCOPE 3

Accurate and transparent data reporting

40 Working with our top 40 suppliers

Continuous engagement and collaboration

Partnership projects

## NET ZERO SCOPE 3 EMISSIONS BEFORE 2050

\* Continued operational efficiency & estate renewal



# WE ARE

Masonry and more.

With over 30 years of manufacturing expertise in Architectural Masonry, our range provides decorative concrete facing blocks and specials, which provide a modern, cost effective building solution.

The decorative concrete facing blocks are maintenance free and are available in a wide selection of colours and textures, with up to 40% recycled materials used across the range.

**We are proud to design a range of Architectural Masonry which delivers up to a 25% reduction in embodied carbon per tonne vs traditional concrete mixes\***

\* This figure was calculated and verified by our concrete materials team.

### Just some of the benefits to specifying Ibstock Architectural Masonry include:

- The products are suitable for internal and external use
- Less wet trades are required on site
- The range can be used below DPC and up to DS-3 conditions
- Excellent fire resistance
- One block per 6 bricks is needed, therefore less mortar is required

### Recycled material content by range

PRODUCT RANGE	COLOUR	SECONDARY AND RECYCLED CONTENTS
DCM	Autumn	15%
DCM	Bathstone	20%
DCM	Damson	15%
DCM	Hallmark Diamond White	0%
DCM	Flint	20%
DCM	Hamstone	20%
DCM	Ivory	10%
DCM	Pewter	15%
DCM	Sandstone	20%
DCM	Sports Green	20%
DCM	Sports Blue	20%
DCM	Spruce	15%
DCM	Straw	20%
DCM	Steel Grey	20%
DCM	Terracotta	20%
DCM	Yorkstone	20%
Novastone	White	40%

AR Residence  
Linear Ivory Shot-blasted







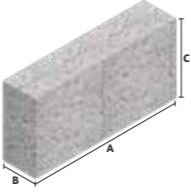
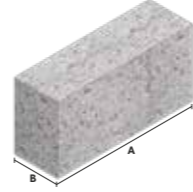
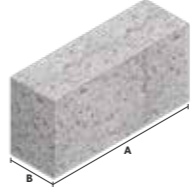
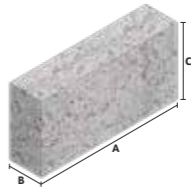
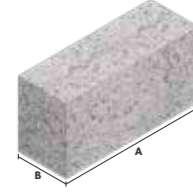

Royal Russell School, Croydon  
Polished Venezia in Bathstone

COLOURS	FAIRFACE	SHOT-BLASTED	SPLITFACE	POLISHED VENEZIA™	POLISHED FLORENTINE®
<b>Pewter</b> Recycled content: 15%					
<b>Steel Grey</b> Recycled content: 20%					
<b>Flint</b> Recycled content: 20%					
<b>Ivory</b> Recycled content: 10%					
<b>Bathstone</b> Recycled content: 20%					
<b>Sandstone</b> Recycled content: 20%					

STANDARD BLOCKS

					
<b>D1</b>	<b>H1</b>	<b>H2 - Hi-Light</b>	<b>K1</b>	<b>P1</b>	<b>B1</b>
A B C WEIGHT	A B C WEIGHT	A B C WEIGHT	A B C WEIGHT	A B C WEIGHT	A B C WEIGHT
440mm 100mm 215mm 19.8KG	440mm 140mm 215mm 28.0KG	440mm 140mm 215mm 19.0KG <small>Not available in Novastone</small>	390mm 90mm 190mm 14.0KG	390mm 140mm 190mm 21.8KG	440mm 100mm 65mm 6.26KG <small>Linear not available in Novastone or Fairface</small>

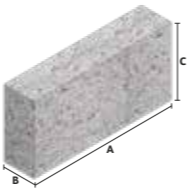
SPLITFACE BLOCKS

	
<b>S4</b>	<b>S1</b>
A B C WEIGHT	A B C WEIGHT
440mm 95mm 215mm 18.9KG	440mm 107.5mm 65mm 6.9KG

RIBLOC

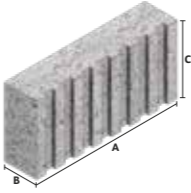
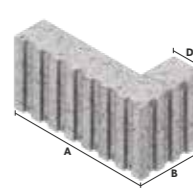
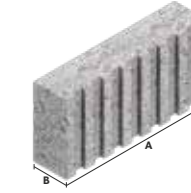
		
<b>E57</b>	<b>E58</b>	<b>E51</b>
A B C WEIGHT	A B+C D WEIGHT	A B C WEIGHT
440mm 100mm 215mm 18.7KG <small>Not available in Novastone</small>	440mm 215mm 100mm 23.7KG <small>Not available in Novastone</small>	390mm 90mm 190mm 13KG <small>Not available in Novastone</small>

THE CLASSIC RANGE

Tradition defined. Our most popular sizes and finishes, for that timeless look.

\*Not recommended for large expanses of block work



# THE PREMIER RANGE

Available in a range of sizes and finishes for guaranteed kerb appeal, every time.

COLOURS	FAIRFACE	SHOT-BLASTED	SPLITFACE	POLISHED VENEZIA™	POLISHED FLORENTINE®
<b>Yorkstone</b> Recycled content: 20%					
<b>Hamstone</b> Recycled content: 20%					
<b>Straw</b> Recycled content: 20%					
<b>Terracotta</b> Recycled content: 20%					
<b>Damson</b> Recycled content: 15% *					
<b>Autumn</b> Recycled content: 15% *					
<b>Spruce</b> Recycled content: 15% *					
<b>Sports Green</b> Recycled content: 20%					

## STANDARD BLOCKS

<b>D1</b>	<b>H1</b>	<b>H2 - Hi-Light</b>	<b>K1</b>	<b>P1</b>	<b>B1</b>
A B C WEIGHT	A B C WEIGHT	A B C WEIGHT	A B C WEIGHT	A B C WEIGHT	A B C WEIGHT
440mm 100mm 215mm 19.8KG	440mm 140mm 215mm 28.0KG	440mm 140mm 215mm 19.0KG <small>Not available in Novastone</small>	390mm 90mm 190mm 14.0KG	390mm 140mm 190mm 21.8KG	440mm 100mm 65mm 6.26KG <small>Linear not available in Novastone or Fairface</small>

## SPLITFACE BLOCKS

<b>S4</b>	<b>S1</b>
A B C WEIGHT	A B C WEIGHT
440mm 95mm 215mm 18.9KG	440mm 107.5mm 65mm 6.9KG

## RIBLOC

<b>E57</b>	<b>E58</b>	<b>E51</b>
A B C WEIGHT	A B+C D WEIGHT	A B C WEIGHT
440mm 100mm 215mm 18.7KG <small>Not available in Novastone</small>	440mm 215mm 100mm 23.7KG <small>Not available in Novastone</small>	390mm 90mm 190mm 13KG <small>Not available in Novastone</small>

\*Not recommended for large expanses of block work



Bromley South Central  
Splitface in Hallmark  
Diamond White and Pewter

COLOURS	FAIRFACE	SHOT-BLASTED	SPLITFACE	POLISHED VENEZIA™	POLISHED FLORENTINE®
<b>Hallmark Diamond White</b> Recycled content: 0%					
<b>Sports Blue</b> Recycled content: 20%					
<b>Novastone White</b> Recycled content: 40%					

STANDARD BLOCKS

<b>D1</b>	<b>H1</b>	<b>H2 - Hi-Light</b>	<b>K1</b>	<b>P1</b>	<b>B1</b>
A B C WEIGHT	A B C WEIGHT	A B C WEIGHT	A B C WEIGHT	A B C WEIGHT	A B C WEIGHT
440mm 100mm 215mm 19.8KG	440mm 140mm 215mm 28.0KG	440mm 140mm 215mm 19.0KG <small>Not available in Novastone</small>	390mm 90mm 190mm 14.0KG	390mm 140mm 190mm 21.8KG	440mm 100mm 65mm 6.26KG <small>Linear not available in Novastone or Fairface</small>

SPLITFACE BLOCKS

<b>S4</b>	<b>S1</b>
A B C WEIGHT	A B C WEIGHT
440mm 95mm 215mm 18.9KG	440mm 107.5mm 65mm 6.9KG

RIBLOC

<b>E57</b>	<b>E58</b>	<b>E51</b>
A B C WEIGHT	A B+C D WEIGHT	A B C WEIGHT
440mm 100mm 215mm 18.7KG <small>Not available in Novastone</small>	440mm 215mm 100mm 23.7KG <small>Not available in Novastone</small>	390mm 90mm 190mm 13KG <small>Not available in Novastone</small>

# THE EXCLUSIVE RANGE

For those extra special projects, where aesthetics and innovation are key.



# WE ARE Linear bricks and more.

You won't believe the lengths we go to...

## ELEGANT, COLOURFUL AND WONDERFULLY LONG CONCRETE BRICKS

Available in lengths up to 440mm in 65mm height, Linear allows you to accentuate the linearity of the façade to create a range of dramatic new effects that take architecture to a new level.

Many different textures and colours means no compromises when it comes to choosing exactly the appearance you want.

## DESIGNING WITH LINEAR BRICKS

Linear opens up a completely new aesthetic for buildings, whilst still maintaining the durability and low maintenance attributes associated with one of our most enduring building materials.

The different dimensions can be easily accommodated with just a little extra thought, yet give you additional flexibility to create a unique canvas for your building.



# SPECIALS AVAILABLE

## 90-DEGREE QUOINS

D16	D16BN	H16	S16
A	A	A	A
B	B	B	B
C	C	C	C
D	D	D	D
WEIGHT	WEIGHT	WEIGHT	WEIGHT
440 215 215 100 25.2KG	440 215 215 100 25.0KG	440 215 215 140 32.5KG	440 215 215 100 24.1KG
Measurements in mm	Measurements in mm Half quoin available ref D15BN	Measurements in mm	Measurements in mm Available as cut and bond only

## CILL BLOCKS

D21	D28	H28
A	A	A
B	B	B
C	C	C
D	D	D
E	E	E
WEIGHT	WEIGHT	WEIGHT
440 40 60 100 115 17.1KG	440 40 100 100 115 23.2KG	35 100 440 215 40 13.2KG
Measurements in mm	Measurements in mm	Measurements in mm Not available in Novastone, Florentine or Venezia
		H28
		A
		B
		C
		D
		E
		WEIGHT
		43 140 440 215 68 17.0KG
		Measurements in mm Not available in Novastone, Florentine or Venezia

## TROUGH LINTELS

Splitface quoins cut & bond only.  
Trough lintels not available in Florentine, Venezia, Novastone or Splitface finish.

Other specials either cut from a standard block or in a cut and bonded format are available upon request.

# WE ARE Hi-Light® blocks and more.

The revolutionary Hi-Light® block has been designed to provide all the benefits associated with dense masonry, yet is up to 25% lighter than an equivalent solid masonry unit.

With a cellular underside but a solid top surface to provide a full bed for mortar, Hi-Light® complies with Health and Safety recommendations and provides complete cover under CDM regulations.



Southern General  
Hospital, Glasgow  
Novastone White

Telephone 03332 343 434



# FINISHES

## FAIRFACE

The original and still the leader in the field.

Fairface masonry offers the benefits of a structural product and finish in one. Its quality finish, dimensional stability, range of subtle, natural colours and economy against competitive materials maintain its position as the leader in its field.



Example:  
Fairfaced Yorkstone

## SPLITFACE

Emulating the rugged appeal of natural hewn stone.

Cost-effective and offering flexibility, Splitface adds a prestigious appearance to any building, whether creating complete, imposing structures or in combination with other Istock products, in feature panels and bands.



Example:  
Splitface Autumn

## POLISHED FLORENTINE®

Affordable prestige inside or out.

Use this to create broad expanses of reflective, decorative walling or in combination with other products to provide impressive highlights - glass finish. Please note, the overall size of a polished block may vary to that stated. Polishing blocks can take up to 2mm off the overall size of a block. This needs to be allowed for in the setting out.



Example:  
Polished Florentine® Straw

## SHOT-BLASTED

Provides a weathered appeal.

Shot-blasted masonry adds a natural weathered appeal. With a broad selection of 'special' shapes and sizes as standard, Shot-blasted offers an almost limitless variety of options.



Example:  
Shot-blasted Sports Green

## BURNISHED VENEZIA™

The subtle beauty of burnished natural aggregates.

A subtly burnished finish brings out all the deeply embedded beauty of the natural aggregates. For projects where reduced glare is a consideration this finish offers an understated beauty for internal or external walls.



Example:  
Burnished Venezia™ Steel Grey

## NOVASTONE

A fine textured masonry finish with time-weathered appeal.

Novastone is a range of components which will give you that natural, weathered appeal from the day they are laid, enabling brand new buildings to blend into established surroundings with impressive ease.



Example:  
Novastone White

# PROFILES

## STANDARD

The most popular profile.

This versatile profile provides a multitude of design possibilities through the range of size and finish options available.



Example:  
Sandstone Standard  
in Shot-blasted finish

## LINEAR

Elegant, colourful and wonderfully long concrete bricks.

The Linear range has been created to give architects the flexibility to create ever more distinctive exteriors, whilst still retaining its beauty, longevity and traditional feel.



Example:  
Sandstone Linear  
in Shot-blasted finish

## RIBLOC®

Bold geometric planes create light and shade.

Ribloc masonry, with its eight ribbed appeal, creates clean lines and a geometric uniformity which will give an imposing appearance to any building. Its ribs provide controlled weathering characteristics.



Example:  
Sandstone Ribloc®  
in Shot-blasted finish

## TWINBLOC™

A 'stack-bonded' appearance with structural integrity.

Twinbloc masonry is the fast, sure, economical way to create the impressive appeal of 'stack bonding'. Created to standard block proportions, Twinbloc incorporates a carefully gauged central groove to give the appearance of two half blocks when laid and yet, as it is laid stretcher-bond, it provides the inherent strength of any DCM wall removing the need for bed-joint reinforcement to stabilise the wall in the majority of situations.



Example:  
Sandstone Twinbloc™  
in Fairface finish

## AIRBLOC

A discrete ventilation block.

Innovations in the manufacturing process of our DCM allows us to offer a product that solves the issue of incorporating adequate ventilation into a cavity wall. The purpose made air block is available in all finishes allowing the same external façade to be maintained.



Example:  
Sandstone Airbloc  
in Shot-blasted finish

## BULLNOSE

Standard 100mm thick block with a 50mm radius bullnose on one end.



Example:  
Yorkshire Bullnose  
in Shot-blasted finish

## BULLNOSE QUOIN

Standard 100mm thick Quoin with a 50mm radius bullnose.



Example:  
Yorkshire Bullnose Quoin  
in Shot-blasted finish

	BULLNOSE	BULLNOSE QUOIN
FAIRFACE	✓	✓
SHOT-BLASTED	✓	✓
SPLITFACE	✓	✓
BURNISHED VENEZIA™	✓	✓
POLISHED FLORENTINE®	✓	✓
NOVASTONE	✓	✓

	STANDARD	LINEAR	RIBLOC®	TWINBLOC™	AIRBLOC
FAIRFACE	✓		✓	✓	✓
SHOT-BLASTED	✓	✓	✓	✓	✓
SPLITFACE	✓	✓	✓	✓	✓
BURNISHED VENEZIA™	✓	✓	✓	✓	✓
POLISHED FLORENTINE®	✓	✓	✓	✓	✓
NOVASTONE	✓		✓	✓	✓





## PROJECT: CONSETT ACADEMY AND LEISURE CENTRE

**LOCATION:**  
Consett Leisure Centre,  
Medomsley Road, Consett DH8 5HU

**PROJECT DESCRIPTION:**  
New Academy and Leisure Centre

**ARCHITECT:**  
Seymour Harris

**PRODUCTS USED:**

- Splitface Yorkstone and specials 428m<sup>2</sup> and 250 specials

- Textured Yorkstone and specials 225m<sup>2</sup> and 1550 specials

- Florentine Pewter and specials 670m<sup>2</sup> and 1100 specials

- Splitface Pewter and specials 330m<sup>2</sup> and 50 specials

- Shot-blasted Pewter 123m<sup>2</sup>

**COLOURS:**



Splitface Florentine and Shot-blasted Pewter

Private residence, London  
Sandstone Fairface



## ARCHITECTURAL MASONRY SPECIFICATION

### MEAN COMPRESSIVE STRENGTH (AIR DRY)

Solid: 17.5N/mm<sup>2</sup>  
Hollow/Cellular: 10.4N/mm<sup>2</sup>

### GROSS DRY DENSITY

Solid: 2100 kg/m<sup>3</sup> Tested to BS EN 772-13  
Cellular & Hollow: Please refer to Masonry Design Guide

\*For gross dry densities, please refer to table 3 in the Forticrete Masonry design guide

### MANUFACTURING TOLERANCE

Please refer to the Masonry Design Guide

### CATEGORY

1

### THERMAL CONDUCTIVITY

Solid: 1.11 W/mK(λ10,dry,unit)  
Based on BS EN 1745:2012 p=50%  
Group 1 Tabulated value, Model S1  
Group 2 Calculated values, Model P4, BS EN ISO 6946 Method (see 'Declaration of Performance' for individual block types)

### DURABILITY AGAINST FREEZE-THAW

PASS (based on PD 6697)

### WATER ABSORPTION

<4g/m<sup>2</sup>.s Tested to BS EN 772-11:2011

### WATER VAPOUR PERMEABILITY

5/15μ based on Table A.3 BS EN 1745:2012

### REACTION TO FIRE

Euroclass A1 based on Commission Decision 2000/605 EC amending 96/603 EC

### SHEAR BOND STRENGTH

0.15 N/mm<sup>2</sup> Shear bond strength (tabulated from EN 998-2:2010 Annex C)

### CONFIGURATION

To EN 1996-1-1  
Solid: Group 1  
Hollow/Cellular: Group 2

### DIMENSIONAL STABILITY

<0.45mm/m Tested to BS EN 772-14:2002

### POLISHED FLORENTINE

The overall size of a polished block may vary to that stated. Polishing blocks can take up to 2mm off the overall size of a block. This needs to be allowed for in the setting out.

Photographer:  
Rob Parish Photography



## PROJECT: INTERNAL OFFICES, LONDON

**LOCATION:**  
Kings Cross, London

**PROJECT DESCRIPTION:**  
Internal offices in Kings Cross

**ARCHITECT:**  
AHMM Architects In London

**PRODUCTS USED:**

- Florentine Ivory

**COLOURS:**



Florentine Ivory



**HEAD OFFICE**

Ibstock plc  
Leicester Road, Ibstock,  
Leicestershire, LE67 6HS

[www.ibstock.co.uk](http://www.ibstock.co.uk)

**T:** 03332 343 434 (Option 2, then option 1)

**E:** [masonry@ibstock.co.uk](mailto:masonry@ibstock.co.uk)



**Ibstock**  
At the heart of building