

WOLF PUP LOOM™ & WOLF PUP LT LOOM™

FL3000
FL3006
FL3009

ASSEMBLY INSTRUCTIONS



WOLF PUP



WOLF PUP LT



Find out more at schachtspindle.com
Schacht Spindle Company 6101 Ben Place Boulder, CO 80301
p. 303.442.3212 f. 303.447.9273

© 2019 Schacht Spindle Company, Inc.

WOLF PUP & WOLF PUP LT

ASSEMBLY INSTRUCTIONS

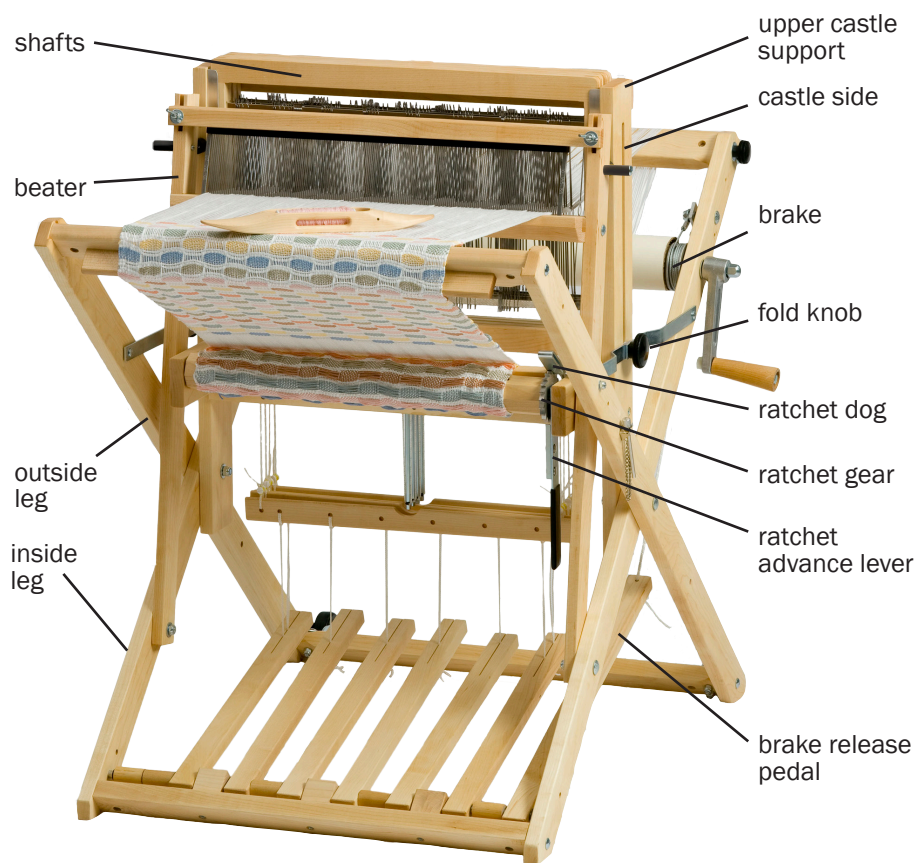

BEFORE YOU BEGIN

- All Wolf looms assemble in a similar way. Watch the Baby Wolf assembly video on our Youtube channel (www.youtube.com/user/schachtspindle).
- You'll find a complete labelled diagram of the Wolf loom in your Maintenance and Warranty manual and at schachtspindle.com.
- Wolf loom legs are called out by where they cross each other. The legs that touch the ground at the front of the loom are called "inside" legs because they are covered by the "outside" legs when they cross at the loom center.
- The beater is at the front of the loom.
- The brake is on the right side of loom.

PARTS

Wrapped onto warp beam:

- 3X apron bars
- 2X lease sticks (with holes)
- 1X front beam extension
- 2X 18" apron cord dowels (cherry looms only)
- 8X heddle bars

Accessory pack:

- 1X brass reed hook
- 1X warp beam crank handle
- 8X 29" apron cords (or 2X 144" apron cords for cherry looms)
- 2X caster & wheel sets
- 1X Treadle Tracker
- 24X tie-up cords (Pup LT only)
- 4X arrow pegs (Pup only)
- 300X heddles
- Maintenance and Warranty Manual

Hardware bag 1:

- 4X 1/4-20 x 1-1/2" Phillips truss head machine screws
- 4X 1/4-20 lock nuts
- 3X 8-15 x 1-1/2" Phillips flat head sheet metal screws

Hardware bag 2:

- 1X 3/8" cap nut
- 1X 3/8" washer
- 2X #12 SAE washers
- 2X 1/4-20 slim lock nuts
- 2X 1/4-20 x 2" Phillips truss head machine screws
- 2X 1" plastic beater pegs

TOOLS

- #2 Phillips screwdriver
- 5/8" and 7/16" or adjustable wrenches
- string
- masking tape (optional)

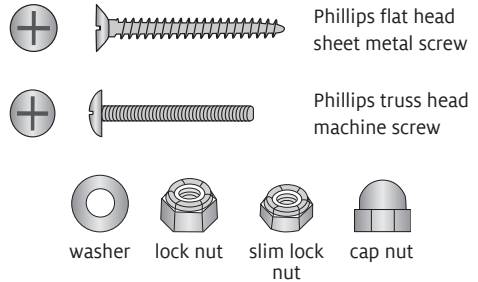

UNFOLDING THE LOOM

1. Remove all plastic wrap from the loom. Remove both shipping braces by slightly loosening the back beam knobs and front beam screws holding them in place. Discard the braces and tighten the knobs and screws. Do not remove the string attaching the beater to the castle.

2. Slightly loosen the black fold knobs on each side of the loom (Figure 1). Generally, a single turn will do.

Loosening the knobs all the way or removing them can cause the loom to collapse, which could result in injury.

3. Stand at the side of the loom. Hold the front and rear beams as you allow the loom to unfold all the way. Push the fold knobs to the bottom of the slots and tighten them.

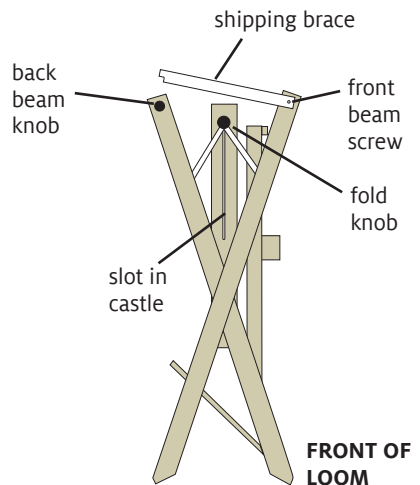

FIGURE 1: UNFOLDING THE LOOM

INSTALLING THE BEATER PEGS

- Loosen the wing nuts holding the top of the beater and remove the beater top. Remove the reed from the beater.
- Insert a 1/4-20 x 2" Phillips truss head machine screw through a 1" plastic beater peg, then through the beater side from its outer side (Figure 2).
- From the inside of the beater, secure the screw with a #12 washer and a 1/4-20 slim lock nut. You may find it helpful to hold the lock nut in place with a wrench.
- Repeat on the other side of the beater. After both pegs are installed, remove the string tying the beater to the castle.

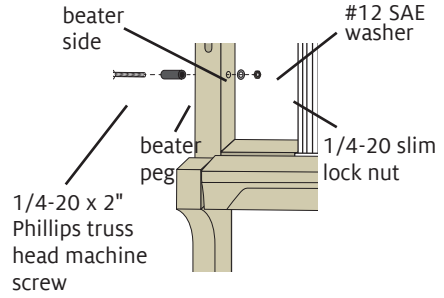

FIGURE 2: INSTALLING BEATER PEGS

ATTACHING THE FRONT BEAM EXTENSION

- Use three 8-15 x 1-1/2" Phillips flat head sheet metal screws to attach the front beam extension to the outside of the front beam (Figure 3). It helps to lubricate the screws with bar soap or paste wax.

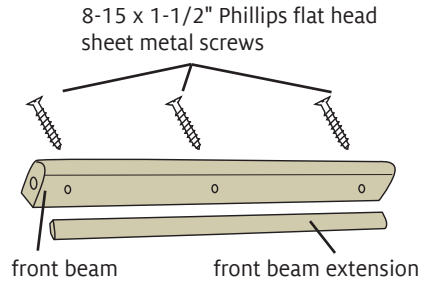

FIGURE 3: ATTACHING FRONT BEAM EXTENSION

ATTACHING THE WARP BEAM CRANK HANDLE

- The warp beam crank handle attaches to a threaded rod on the inside right leg (Figure 4). Locate the washer, cap nut, and the warp beam crank handle in the accessory pack. Place the 3/8" washer and then the metal handle on the rod, with the wooden handle facing out. Secure with the 3/8" cap nut.

When you're weaving, the crank should be pushed off of the cap nut. To engage the crank for turning the warp beam, pull the hexagonal hole in the crank onto the cap nut.

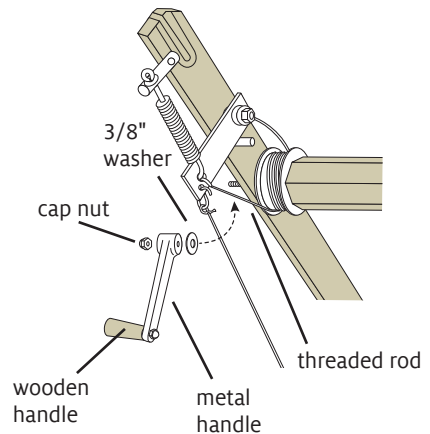

FIGURE 4: ATTACHING WARP BEAM CRANK HANDLE

ATTACHING THE APRON BARS

For cherry Wolf looms, see the special instructions for attaching the apron bars.

10. There is one cord for each hole in the cloth and warp beams. Insert one end of a cord through a hole in the beam and pull the cord through. Then insert the other end through the second hole in the end of the cord that you just put through the beam. Pull firmly on the cord to tighten (Figure 5A). Repeat across the cloth beam and the warp beam.

11. To attach the apron bar to the apron cords, take a pinch of the cord about 4" from the end (Figure 5B). Insert the pinched cord through the second hole in the cord. Pull on the pinched cord until a new loop forms that is large enough for the apron bar to slip through (Figure 5C). Slide the apron bar through the loop (Figure 5D) and pull tight. Repeat until all cords are attached to the apron bar. Attach the other apron bar to its beam in the same way.

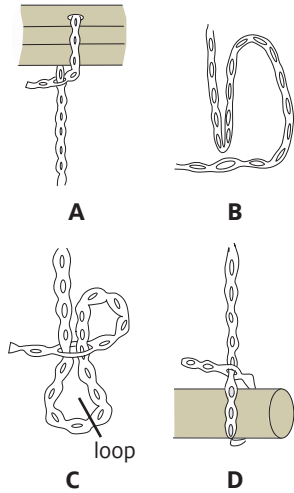

FIGURE 5: INSTALLING APRON CORDS

Visit [youtube.com/user/schachtspindle](https://www.youtube.com/user/schachtspindle) for an apron cord installation video.

INSTALLING THE HEDDLES

12. Determine how many heddles you want on each shaft. Count out the desired number, then thread a string through the holes at each end of the heddles and tie them (Figure 6). String a group of heddles for each shaft.

13. Slide each group of heddles onto a pair of heddle bars (Figure 7). To make threading easier, it is important to orient the heddles in the same direction on each pair of heddle bars.

On inserted eye heddles, the red end of the heddles goes at the bottom for left-handed threading or at the top for right-handed threading.

14. Optional: To keep the heddles from sliding around during the next steps, tape each group of heddles to their heddle bars with masking tape.

15. Lift the shaft frame closest to the front of the loom and prop it up using a book

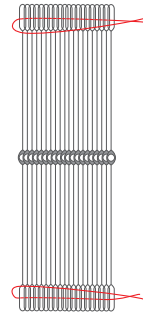

FIGURE 6: THREADING HEDDLES ONTO STRING

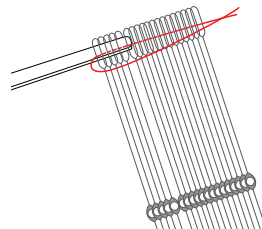

FIGURE 7: SLIDING HEDDLES ONTO HEDDLE BAR

or small block of wood. The bottom of the shaft frame should be raised 3 to 4 inches (Figure 8).

16. Working from the rear of the loom, lower a pair of heddle bars with heddles into the castle in front of the raised shaft frame.

17. Insert the heddle bars into the slots on one side of the shaft frame. Bend the heddle bars and insert the other ends into the other sides of the shaft frame. Remove the string ties and any tape you used.

18. Repeat Steps 16 and 17 on the remaining shafts, working from the rear of the loom and adding heddles to shafts from the front to back of the loom.

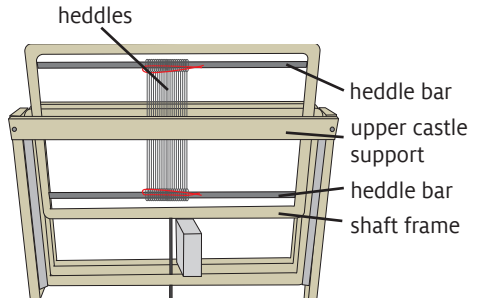

FIGURE 8: INSTALLING HEDDLE BARS

**WOLF PUP LT:
INSTALLING TIE-UP CORDS**

19. There is one tie-up cord for each hole in the lamms. Put the loop end of a tie-up cord through each hole and pull the button end through the loop until the cord is secure against the lamm (Figure 9).

Tie the lamms to treadles by slipping a tie-up cord into the slot in the treadle (Figure 9). Work from the front lamm to the rear lamm for each treadle. After you have completed your tie-up, check each treadle by pushing it all the way to the floor and releasing it, making sure that the knob of each tie-up cord is up against the treadle and that each cord hangs straight down to the treadle.

There is a 1/2" round depression on the underside of each treadle end to prevent the tie-ups from slipping off when the loom is folded.

**WOLF PUP:
ATTACHING TREADLE CORDS**

20. Untie the treadle cords from the castle and remove the arrow pegs from their loose ends. Thread each cord through the hole in its corresponding treadle. Fasten the cord by inserting an anchor peg through a hole in the cord under the treadle. Adjust the placement of the anchor pegs so that the ends of the treadles are all at the same height, approximately 6" from the floor.

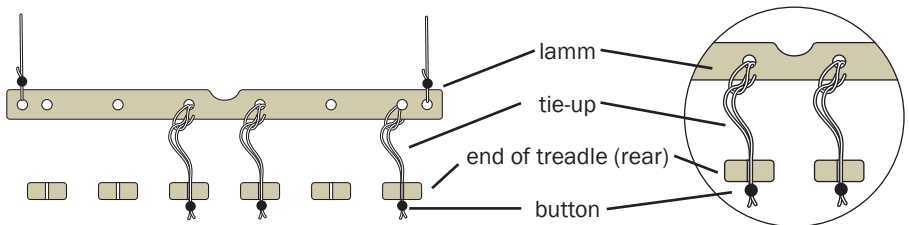

FIGURE 9: INSTALLING TIE-UP CORDS

INSTALLING THE WHEELS

21. Skip this step if you will install a stroller on your loom. With the loom unfolded, install the wheels. Use two 1/4-20 x 1-1/2" Phillips truss head machine screws and two 1/4-20 lock nuts to attach each wheel to the rear leg brace (Figure 10).

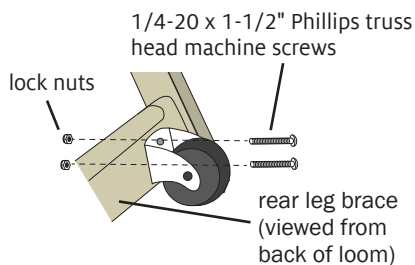

FIGURE 10: INSTALLING THE WHEELS

INSTALLING THE TREADLE TRACKER

TRACKER

22. With the clip on the treadle tracker facing the front of the loom, insert the treadle tracker into the slot in the top of the upper castle support (Figure 11).

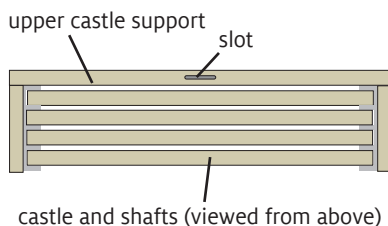

FIGURE 11: TREADLE TRACKER

USING THE BEATER PIN

23. The small metal pin attached to the right outside leg holds the beater upright during warping. Leave the beater pin in its holder when you're weaving or folding the loom (Figure 12A). To engage the pin for warping, align the hole in the right outside leg with the slot in the beater side. Insert the pin through the hole and into the slot (Figure 12B).

REMOVING THE BACK BEAM

24. The back beam can be removed for better access to the heddles when you thread the loom. Loosen the back beam knobs on each side of the back beam and lift the beam out (Figure 13). To replace the back beam, slide the beam back into the legs and tighten the knobs.

When you move the loom, be sure to lift it using the cloth and warp beams, not the front and back beams.

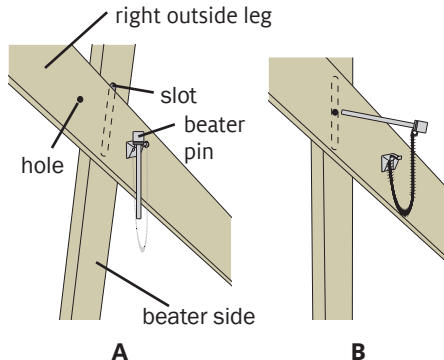

FIGURE 12: USING THE BEATER PIN

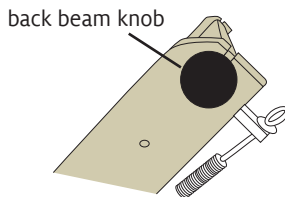

FIGURE 13: BACK BEAM

ADJUSTING THE FRICTION BRAKE

25. The friction brake can be adjusted by tightening or loosening the eye bolt (Figure 14). This will increase or decrease the tension on the spring, which will in turn increase or decrease the tension on the brake bar and the brake cable.

Always press down on the brake pedal while you are winding on the warp or advancing the warp on the cloth beam.

FOLDING THE LOOM

26. To prevent treadles from dragging on the floor when the loom is folded, attach every treadle to at least one tie-up cord.

27. Start folding the loom: Loosen the fold knobs one full turn and pull them up in their slots (Figure 1, page 3).

28. With one hand on the rear beam and one hand on the front beam, push the loom together as far as it will go. Tighten the fold knobs. ■

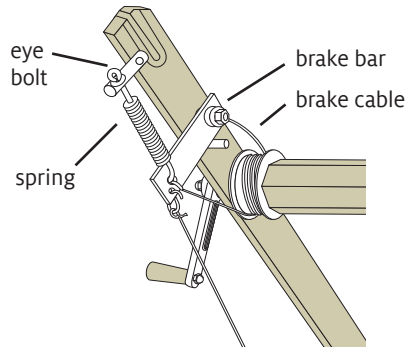

FIGURE 14: FRICTION BRAKE

WOLF PUP & PUP LT ACCESSORIES



WOLF STROLLER



LOOM BENCH



WOLF TRAP



HIGH CASTLE TRAY



DOUBLE BACK BEAM



SECTIONAL BEAM