

FLENDER COUPLINGS

FASTEX

Compact assembly and operating instructions 3907en

Edition 05/2022

FASTEX IC240

FLENDER

FLENDER

FLENDER COUPLINGS

FASTEX IC240 Clamping elements 3907en

Compact assembly and
operating instructions

Introduction	1
Description	2
Application planning	3
Assembly	4
Disassembly	5
Disposal	6
Services and support	7
Technical data	A

Legal information

Warning notice system

This manual contains notices you have to observe in order to ensure your personal safety, as well as to prevent damage to property. The notices referring to your personal safety are highlighted in the manual by a safety alert symbol, notices referring only to property damage have no safety alert symbol. These notices shown below are graded according to the degree of danger.

 DANGER
indicates that death or severe personal injury will result if proper precautions are not taken

 WARNING
indicates that death or severe personal injury may result if proper precautions are not taken.

 CAUTION
indicates that minor personal injury can result if proper precautions are not taken.

NOTICE
indicates that property damage can result if proper precautions are not taken.

If more than one degree of danger is present, the warning notice representing the highest degree of danger will be used. A notice warning of injury to persons with a safety alert symbol may also include a warning relating to property damage.

Qualified Personnel

The product/system described in this documentation may be operated only by **personnel qualified** for the specific task in accordance with the relevant documentation, in particular its warning notices and safety instructions. Qualified personnel are those who, based on their training and experience, are capable of identifying risks and avoiding potential hazards when working with these products/systems.

Proper use of Flender products

Note the following:

 WARNING
Flender products may only be used for the applications described in the catalog and in the relevant technical documentation. If products and components from other manufacturers are used, these must be recommended or approved by Flender. Proper transport, storage, installation, assembly, commissioning, operation and maintenance are required to ensure that the products operate safely and without any problems. The permissible ambient conditions must be complied with. The information in the relevant documentation must be observed.

Trademarks

All names identified by ® are registered trademarks of Flender GmbH. The remaining trademarks in this publication may be trademarks whose use by third parties for their own purposes could violate the rights of the owner.

Disclaimer of Liability

We have reviewed the contents of this publication to ensure consistency with the hardware and software described. Since variance cannot be precluded entirely, we cannot guarantee full consistency. However, the information in this publication is reviewed regularly and any necessary corrections are included in subsequent editions.

Table of contents

1	Introduction	5
1.1	Main operation instructions	5
1.2	General information	5
1.3	Intended use	6
1.4	Safety instructions for a clamping element for use in potentially explosive atmospheres	6
2	Description	7
3	Application planning	8
3.1	Transport of the clamping element	8
3.1	Storage of the clamping element	8
4	Assembly	9
4.1	Assembling the clamping element	10
5	Disassembly	11
6	Disposal	12
7	Service und support	12
A	Technical data	13
A.1	Geometry data and tightening torques	13

Tables

Table 1-1	General warnings	5
Table 4-1	Recommended assigned fits	9
Table 7-1	Geometry data, weights, tightening torques	14

Figures

Figure 2-1	Construction of the clamping element FASTEX IC240	7
Figure 4-1	Fit assignment	9
Figure 4-2	Alignment clamping element	10
Figure 7-1	Parts overview FASTEX IC240	13

1 Introduction

1.1 Main operation instructions

These instructions are only valid in conjunction with the associated operating instructions from the component supplier.

1.2 General information

Instructions











Notice the information and regulations in these installation instructions and in the main operating instructions from the component supplier.

Please make sure that every person who is commissioned to work on the clamping element has read and understood these instructions prior to handling the clamping element and observes all of the points.

Only the knowledge of these instructions can avoid faults on the clamping element and ensure fault-free and safe operation. Non-adherence to the instructions can cause product or property damage or personal injury. Flender does not accept any liability for damage or operating failures that are due to non-adherence to these instructions.

Symbols

Table 1-1 General warnings

ISO	ANSI	Warning
		Warning - hazardous electrical voltage
		Warning - explosive substances
	---	Warning - entanglement hazard
	---	Warning - hot surfaces
	---	Warning - substances that are harmful to health or are irritants
	---	Warning - corrosive substances
	---	Warning - suspended load
	---	Warning - hand injuries
		ATEX certification

Explanation regarding Machinery Directive 2006/42/EG

The clamping elements described here are components in accordance with the Machinery Directive and do not require a declaration of incorporation.

Work on the clamping element

Only carry out work on the clamping element when it is not in operation and is not under load. Secure the drive unit against being switched on accidentally. Attach a notice to the switch stating clearly that work is being carried out on the clamping element. Ensure that the entire unit is not under load..

1.3 Intended use

Only use the clamping element according to the conditions specified in the service and delivery contract and the technical data in the annex. Deviating operating conditions are considered improper use. The user or owner of the machine or plant is solely liable for any resulting damage.

When using the clamping element please specifically observe the following:

- Do not make any modifications to the clamping element that go beyond the permissible machining described in these instructions. This also applies to touch protection facilities.
- Do not use the clamping element as a torque-limiting safety element.

If you have any queries, please contact our customer service (see Service and support (Page 12)).

1.4 Safety instructions for a clamping element for use in potentially explosive atmospheres



The assembly supplier is responsible for the guideline-compliant design of the system clamping element with all associated components. In potentially explosive areas, it must be ensured that the design torque T_{Cl} according to Table 7-1 is not exceeded at any operating point. The identification and information on the conditions of use can be found in the main operating instructions of the assembly supplier.

2 Description

The clamping elements described here are universally applicable, self-centering clamping elements whose function is the tensionally locked transmission of torque between shaft and hub.

The installation and operation of the specified clamping elements in combination with cylindrically bored hubs is described in these instructions.

Design

Detailed information on the dimensions can be found in Appendix A Technical data (Page 13).

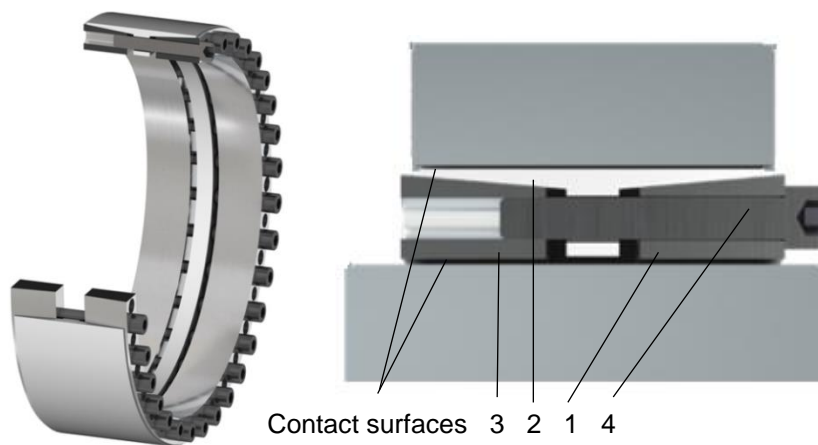

- 1 Frontal pressur ring
- 2 Outer ring
- 3 Rear pressure ring
- 4 Cylinder-head screw

Figure 2-1 Construction of the clamping element FASTEX IC240

3 Application planning

Check the delivery for damage and for completeness. Report any damage and/or missing parts to Flender immediately.

The coupling is delivered in preassembled groups. These may be dismantled.

3.1 Transport of the clamping element



WARNING

Severe personal injury due to improper transport

Severe personal injury due to falling components or due to crushing. Damage to clamping element parts possible due to use of unsuitable transport means.

- Only use lifting gear and load suspension devices with sufficient load bearing capacity for transport.
- Please observe the symbols applied on the packaging.

3.1 Storage of the clamping element

The clamping element, unless not specifically ordered otherwise, is supplied with preservation and can be stored for up to 12 months in a dry and dust-free storage room.

4 Assembly



DANGER

Danger due to bursting of the assembly group

If not used as intended, the assembly can burst. There is a risk of fatal injury from flying fragments. Bursting of the assembly can lead to an explosion in potentially explosive atmospheres.

- Use the clamping element as intended

Note

Information about the assembly of the clamping element

- Only use undamaged components for the assembly of the clamping element.
- Follow the assembly sequence.
- Please ensure that there is sufficient space at the assembly location and that the location is tidy and clean in order to be able to assemble and maintain the clamping element without any risk.
- If a dimension drawing has been created for the clamping element, please observe the information it contains as a matter of priority

Recommended assigned fits

In the following table you will find the permissible fits of the clamping element and the shaft.

Table 4-1 Recommended assigned fits

component	tolerance	surface quality
Shaft tolerance	h8	$R_a \leq 3,2 \mu\text{m}$
Bore tolerance	H8	$R_a \leq 3,2 \mu\text{m}$

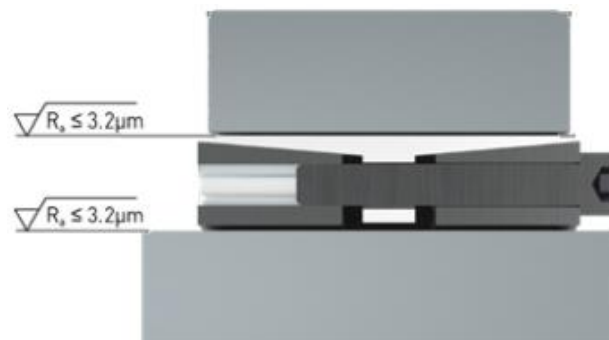

Figure 4-1 Fit assignment

4.1 Assembling the clamping element



WARNING

The design torque T_{C1} must not be exceeded at any operating point. It must be ensured that the cylinder head bolts are tightened with the tightening torques according to Table 7-1

Preparatory work

1. Make sure the surfaces to be joined are in perfect condition.
2. Clean the contact surfaces as well as the shaft and hub.
3. Slightly oil the contact surfaces. Do not use any grease or oil that contains molybdenum disulfide or other additives that significantly reduce the coefficient of friction.
4. Insert the frontal pressure ring (1) and the rear pressure ring (3) into the outer ring (2). Place the rear pressure ring (3), the frontal pressure ring (1) and outer ring (2) that the slots are aligned with each other and offset to the forcing threads.
5. Screw the frontal pressure ring (1) and the rear pressure ring (3) without tightening the cylinder-head screws (4).

Assemble

1. Position the pre-assembled clamping element in the hub bore and then place both parts on the shaft.
2. Slightly tighten the cylinder-head screws (4) so that the clamping element can still be moved.
3. Align the Clamping element on the shaft.
4. The shaft must fill the entire length of the clamping element.
5. Tighten the cylinder-head screws (4) crosswise in several turns. The specified tightening torque can be found in the Tightening torques and widths A/F section.

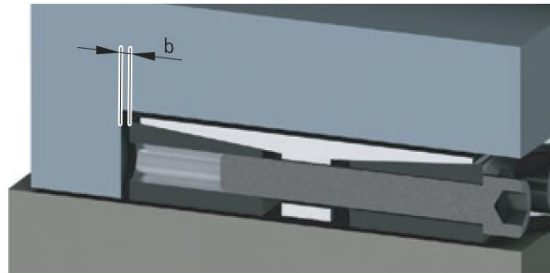

Formula for calculating the clearance during disassembly

$$b = \frac{L1 - L2}{2}$$

Figure 4-2 Alignment clamping element

5 Disassembly

Procedure

1. Loosen and remove all cylinder-head screws (4) one after the other.
2. Screw the cylinder-head screws (4) into the existing release threads of the frontal pressure ring (1).
3. Remove the clamping element. Use suitable lifting gear when doing this.
4. Check the hub bore and the shaft for damage and protect them against corrosion.

When reinstalling the clamping element please observe the information in the chapter Assembly (Page 10).

6 Disposal

Dispose of the clamping element parts according to applicable national regulations or recycle them.

7 Service und support

When ordering spare parts, requesting a customer service technician or in the case of technical queries, please contact our factory or one of our customer service addresses:

Flender GmbH

Schlavenhorst 100

46395 Bocholt

Deutschland

Tel.: +49 (0)2871/92-0

Fax.: +49 (0)2871/92-2596

Flender GmbH (<http://www.flender.com>)

A Technical data

A.1 Geometry data and tightening torques

In this section you can find dimension drawings and technical data for the Flender clamping elements.:

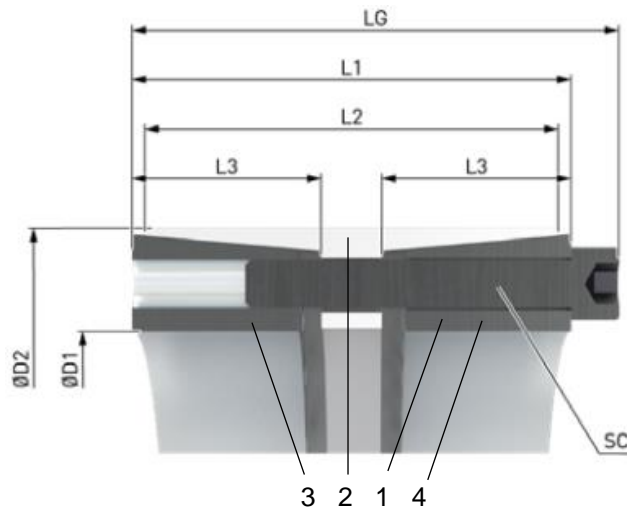

- 1 Frontal pressur ring
- 2 Outer ring
- 3 Reat pressure ring
- 4 Cylinder-head screw

Figure 7-1 Parts overview FASTEX IC240

Table 7-1 Geometry data, weights, tightening torques

Size	Dimensions				Limit Torque	Hexagon socket-head screws acc. to DIN EN ISO 4762 - 12.9					Weight
						Screw size	Tightening torque	Quantity	Screwlength	widht A/F	
D ₁ x D ₂	L _G	L ₁	L ₂	L ₃	T _{Cl}	SC	T _A		L _s	SW	m
mm	mm	mm	mm	mm	Nm	mm	Nm		mm	mm	kg
24 x 50	51	45	41	16	700	M6	17	6	35	5	0,54
25 x 50	51	45	41	16	730	M6	17	6	35	5	0,53
28 x 55	51	45	41	16	1100	M6	17	8	35	5	0,50
30 x 55	51	45	41	16	1180	M6	17	8	35	5	0,47
32 x 60	51	45	41	16	1270	M6	17	8	35	5	0,77
35 x 60	51	45	41	16	1390	M6	17	8	35	5	0,71
38 x 65	51	45	41	16	1880	M6	17	10	35	5	1,10
40 x 65	51	45	41	16	1980	M6	17	10	35	5	1,06
40 x 75	51	45	41	16	2880	M8	41	8	35	6	1,10
42 x 75	51	45	41	16	3000	M8	41	8	35	6	1,16
45 x 75	51	45	41	16	3250	M8	41	8	35	6	1,08
48 x 80	70	62	58	23	3450	M8	41	8	55	6	1,45
50 x 80	70	62	58	23	3600	M8	41	8	55	6	1,38
55 x 85	70	62	58	23	3950	M8	41	8	55	6	1,49
60 x 90	70	62	58	23	5400	M8	41	10	55	6	1,60
65 x 95	70	62	58	23	5850	M8	41	10	55	6	1,70
70 x 110	86	76	70	28	10200	M10	83	10	60	8	3,10
75 x 115	86	76	70	28	10950	M10	83	10	60	8	3,29
80 x 120	86	76	70	28	14000	M10	83	12	60	8	3,46
85 x 125	86	76	70	28	15000	M10	83	12	60	8	3,64
90 x 130	86	76	70	28	15800	M10	83	12	60	8	3,80
95 x 135	86	76	70	28	16800	M10	83	12	60	8	4,00
100 x 145	110	98	92	35	26000	M12	145	12	80	10	6,10
110 x 155	110	98	92	35	28600	M12	145	12	80	10	6,60
120 x 165	110	98	92	35	36300	M12	145	14	80	10	7,10
130 x 180	128	114	108	41	46000	M14	230	12	90	12	10,00
140 x 190	128	114	108	41	57800	M14	230	14	90	12	10,60
150 x 200	128	114	108	41	70800	M14	230	16	90	12	11,20
160 x 210	128	114	108	41	75500	M14	230	16	90	12	11,90
170 x 225	162	146	136	52	95900	M16	355	14	110	14	17,60
180 x 235	162	146	136	52	108800	M16	355	15	110	14	18,50
190 x 250	162	146	136	52	122500	M16	355	16	110	14	21,40
200 x 260	162	146	136	52	128900	M16	355	16	110	14	22,40
220 x 285	162	146	136	52	171800	M16	355	18	110	14	26,60
240 x 305	162	146	136	52	208000	M16	355	20	110	14	28,70
260 x 325	166	150	134	55	237000	M16	355	21	110	14	31,23
280 x 355	197	177	165	66	340000	M20	690	18	130	17	46,77
300 x 375	197	177	165	66	405000	M20	690	20	130	17	69,72
320 x 405	197	177	165	66	453000	M20	690	21	130	17	60,52
340 x 425	197	177	165	66	504900	M20	690	22	130	17	63,86
360 x 455	224	203	190	76	626000	M22	930	21	150	17	86,78
380 x 475	224	203	190	76	692000	M22	930	22	150	17	91,04
400 x 495	224	203	190	76	795000	M22	930	24	150	17	95,30
420 x 515	224	203	190	76	835000	M22	930	24	150	17	100,00
440 x 535	224	203	190	76	875000	M22	930	24	150	17	105,00
460 x 555	224	203	190	76	914000	M22	930	24	150	17	109,00
480 x 575	224	203	190	76	1113000	M22	930	28	150	17	114,00
500 x 595	224	203	190	76	1160000	M22	930	28	150	17	119,00
520 x 615	224	203	190	76	1292000	M22	930	30	150	17	122,50
540 x 635	224	203	190	76	1342000	M22	930	30	150	17	128,00
560 x 655	224	203	190	76	1484000	M22	930	32	150	17	131,00
580 x 675	224	203	190	76	1537000	M22	930	32	150	17	136,00
600 x 695	224	203	190	76	1640000	M22	930	33	150	17	139,00

FASTEX IC240
Compact assembly and operating instructions 3907de
Edition 05/2022

[Flender GmbH](#)
Alfred-Flender-Straße 77
46395 Bocholt
Germany

flender.com

FLENDER