

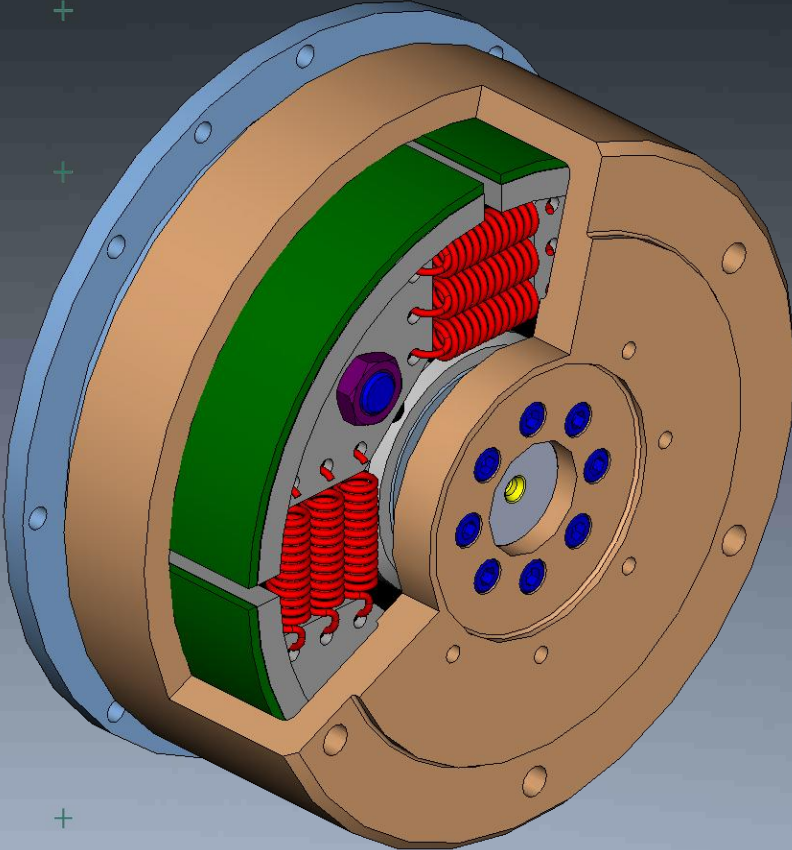

# CENTASTART

Assembly and operating instructions  
0060-00080...02500-VF/-CO/-SP/-G./-CL  
M006-00001-EN  
Rev. 1



Power Transmission  
Leading by innovation



## Contents

<b>1</b>	<b>General remarks .....</b>	<b>5</b>
<b>2</b>	<b>Safety .....</b>	<b>6</b>
2.1	Safety remarks .....	6
2.1.1	Signal words .....	6
2.1.2	Pictograms .....	7
2.2	Qualification of deployed personnel .....	7
2.3	Intended application.....	7
2.4	Application not in compliance with the intended use .....	9
<b>3</b>	<b>Delivery, transport, storage and disposal .....</b>	<b>10</b>
3.1	Delivery .....	10
3.2	Transport.....	10
3.3	Storage .....	10
3.3.1	Storage location.....	11
3.3.2	Storage of couplings / flexible elements .....	11
3.4	Disposal.....	11
<b>4</b>	<b>Technical description .....</b>	<b>12</b>
4.1	Characteristics.....	12
4.2	Specifications .....	12
<b>5</b>	<b>Mounting .....</b>	<b>13</b>
5.1	General assembly instructions .....	13
5.2	Mounting the coupling .....	15
5.3	Mounting the pre-mounted coupling to the flywheel .....	16
5.4	Mounting the coupling in single parts .....	17
5.4.1	Dismantling the pot.....	17
5.4.2	Mounting the assembly to the flywheel .....	18
5.4.3	Mounting the pot .....	19
5.5	Mounting the output drive to the coupling .....	20
5.5.1	Mounting the output drive to couplings of type VFCL/VFSP .....	20
5.5.2	Mounting the output drive to couplings of type VFG.....	21
5.5.3	Mounting the output drive to couplings of type VFCL .....	21
5.6	After completed mounting.....	21
<b>6</b>	<b>Operation.....</b>	<b>22</b>
6.1	Operating faults, root causes and remedy .....	22



<b>7</b>	<b>Care and maintenance .....</b>	<b>23</b>
7.1	Work to be performed .....	23
7.1.1	Cleaning the coupling .....	23
7.1.2	Visual inspection of the coupling .....	23
7.1.3	Checking thickness of friction linings .....	24
7.1.4	Check diameter of outer part.....	25
7.1.5	Inspection of the screw connections .....	26
7.2	Replacing defective parts .....	26
<b>8</b>	<b>Dismantling .....</b>	<b>27</b>
8.1	General dismantling instructions .....	27
8.2	Dismantling the output drive from the coupling .....	28
8.2.1	Dismantling the output drive from the couplings type VFCO/VFSP .....	28
8.2.2	Dismantling the output drive from the couplings type VFG. ....	28
8.2.3	Dismantling the output drive from the couplings type VFCL .....	28
8.3	Dismantling the pot (if necessary) .....	28
8.4	Dismantling the pre-mounted coupling/assembly from the flywheel .....	28
8.5	Dismantling the assembly inner part from the adapter (if necessary) .....	29
8.5.1	Mounting the pre-mounted assembly inner part to the adapter.....	29
8.6	Reassembling the coupling.....	29
<b>9</b>	<b>Wearing and spare parts.....</b>	<b>30</b>
<b>10</b>	<b>Annex .....</b>	<b>31</b>
10.1	CENTA data sheet D013-016 (unlubricated screw connections) .....	31
10.2	CENTA data sheet D006-900 Declaration of incorporation according to the EC Machinery Directive 2006/42/EC, Appendix II B.....	32



## **Index of illustrations**

Fig. 5-1 Bores accessible / Bores not accessible .....	15
Fig. 5-2 Mounting the pre-mounted coupling to the flywheel .....	16
Fig. 5-3 Dismantling the pot.....	17
Fig. 5-4 Mounting the assembly to the flywheel .....	18
Fig. 5-5 Mounting the pot .....	19
Fig. 5-6 Mounting the output drive to couplings of type VFCO/VFSP .....	20
Fig. 7-1 Checking thickness of friction linings (example CS-400).....	24
Fig. 7-2 Check diameter of the outer part (example CS-400) .....	25
Fig. 8-1 Dismantling the assembly inner part from the adapter.....	29

## **Index of tables**

Table 2-1 Shape and size of ventilation holes .....	8
Table 6-1 Troubleshooting table .....	22
Table 7-1 Thickness of friction linings and diameter of outer part.....	26



## **1 General remarks**

These assembly and operating instructions form a constituent part of the coupling delivery and must be kept in an easily accessible place at all times.

CENTA products are developed and produced to quality standard DIN EN ISO 9001:2000.

In the interests of further development, CENTA reserves the right to make technical changes.



### **IMPORTANT**

CENTA is unable to accept liability for damage and operating faults caused by failure to observe the operating instructions.

These operating instructions are protected under copyright to CENTA Antriebe Kirschey GmbH.

In case of technical questions, please enquire with our head office:

**CENTA Antriebe  
Kirschey GmbH**  
Bergische Strasse 7  
42781 Haan  
GERMANY  
Phone +49-2129-912-0  
Fax +49-2129-2790  
centa@centa.de  
www.centa.info

## 2 Safety

The purpose of these operating instructions is to enable users to:

- use the coupling safely and correctly
- maximize efficiency
- ensure that care and maintenance are carried out correctly

For this reason, these operating instructions must be thoroughly read and understood prior to work on and with the coupling.

<b>WARNING</b>	
	<p><b>Injury and material damage can occur as a result of:</b></p> <ul style="list-style-type: none"><li>▪ Failure to adhere to the safety and accident prevention regulations valid at the relevant installation site</li></ul> <p>The safety and accident prevention regulations valid at the installation site in question must be adhered to when performing any of the tasks described in these operating instructions.</p>

### 2.1 Safety remarks

In these operating instructions, safety remarks are indicated by a pictogram and a signal word.

#### 2.1.1 Signal words

The following signal words are used in the safety remarks:

**DANGER** Denotes the immediate threat of danger.  
If not prevented, fatal or extremely serious injuries can result.

**WARNING** Denotes a potentially dangerous situation.  
If not prevented, fatal or extremely serious injuries can result.

**CAUTION** Denotes a potentially dangerous situation.  
If not prevented, minor injuries and/damage to property may result.

**IMPORTANT** Denotes application tips and particularly useful information. This is not a signal word denoting a dangerous or damaging situation.

### 2.1.2 Pictograms

Possible pictograms in the safety precautions:



Warning of a hazardous area



Do not switch



Use protective gloves



Use protective goggles

### 2.2 Qualification of deployed personnel

All the work described in these operating instructions may only be performed by authorized persons with adequate training and instruction.

<b>WARNING</b>	
	<p><b>Injury and material damage can occur as a result of:</b></p> <ul style="list-style-type: none"> <li>▪ Work at the coupling which is not described in these instructions</li> </ul> <p>Only carry out work which is described in these operating instructions.</p>

### 2.3 Intended application

<b>WARNING</b>	
	<p><b>Injury and material damage can occur as a result of:</b></p> <ul style="list-style-type: none"> <li>▪ Application not in compliance with the intended use</li> </ul> <p>The couplings are intended exclusively for use in accordance with the relevant design. They may only be used under the specified conditions.</p>

## WARNING



**Injuries can occur as a result of:**

- Contact with rotating parts

Shield the coupling in accordance with the applicable accident prevention regulations with an enclosure.

**Exception:**

The coupling is encased by the driving and driven units.

**The scope of delivery provided by CENTA does not include a protective enclosure.**

This enclosure must fulfil the following criteria:

- Provide protection against persons gaining access to rotating parts
- Restrain any rotating parts which may be work loose
- Guarantee sufficient ventilation for the coupling

This enclosure must be made of stable steel components. In order to ensure adequate ventilation for the coupling, the enclosure must be fitted with regular openings. For safety reasons, these openings must not exceed the dimensions outlined in table 2-1.

Component	Circular openings [mm]	Rectangular openings [mm]
Top of the enclosure	Ø 8	□ 8
Side elements of the enclosure	Ø 8	□ 8

*Table 2-1 Shape and size of ventilation holes*

The enclosures must be positioned a minimum of 15 mm distant from rotating parts. The enclosure must be electrically conductive and be included in the equipotential bonding.

Before commencing long-term operation, the plant must successfully complete a test run.



## 2.4 Application not in compliance with the intended use

<b>WARNING</b>	
	<p><b>Injury and material damage can occur as a result of:</b></p> <ul style="list-style-type: none"><li>▪ Inadmissibly high torque</li><li>▪ Inadmissibly high or low speeds</li><li>▪ Exceeding the specified ambient temperature</li><li>▪ Inadmissible ambient medium</li><li>▪ Inadmissible coupling enclosure</li><li>▪ Exceeding the admissible overall misalignment values</li></ul> <p>Only use the coupling for the specified application.</p>

CENTA bears no liability for damage resulting from application not in compliance with the intended use of the equipment.  
Should there be a change of plant parameters, the coupling design must be reviewed by CENTA (address see chapter 1).



### 3 Delivery, transport, storage and disposal

#### 3.1 Delivery

After delivery, the coupling:

- must be checked for completeness and correctness of the delivery.
- must be examined for possible transport damage (which must be reported immediately to the carrier).



#### 3.2 Transport

<b>CAUTION</b>	
	<p><b>Injury and material damage can occur as a result of:</b></p> <ul style="list-style-type: none"> <li>▪ Incorrect transportation of couplings</li> </ul> <p>Ensure that the coupling is correctly transported.</p>
<b>CAUTION</b>	
	<p><b>Material damage to coupling components can occur as a result of:</b></p> <ul style="list-style-type: none"> <li>▪ Contact with sharp-edged objects</li> </ul> <p>Protect coupling components for transportation. Only hoist coupling components with nylon belts or ropes. Always cushion parts when supporting them from below.</p>

Following transportation damage:

- Check the coupling carefully for damage.
- Consult the manufacturer (Address see chapter 1).

#### 3.3 Storage

<b>CAUTION</b>	
	<p><b>Material damage to elastic elements and rubber parts can occur as a result of:</b></p> <ul style="list-style-type: none"> <li>▪ Incorrect storage</li> </ul> <p>These parts must be stored laid flat and so they cannot distort, and protected from ozone, heat, light, moisture and solvents.</p>
 <b>IMPORTANT</b>	
<p>Rubber parts are marked where possible with their production date. From this date, they may only be stored for a maximum of 5 years.</p>	

### 3.3.1 Storage location

Requirements imposed on the storage location:

- Moderately ventilated and low in dust
- Dry (max. 65% humidity)
- Temperature stabilized (-10°C to +25°C)
- Free of ozone-producing devices such as light sources and electric motors
- Free of UV light sources and direct sunlight
- Do not store solvents and disinfectants, fuels or lubricants, acids, chemicals etc. in the same location

For more details, refer to DIN 7716.

### 3.3.2 Storage of couplings / flexible elements

- Unpack the parts.
- Check the packaging for damage. Replace if necessary.
- Check that the wax protection on steel components is intact. If necessary, patch or renew.
- Package the parts (for prolonged periods of storage, enclose desiccant and weld into film).
- Place the parts into storage.

## 3.4 Disposal

<b>RECYCLING</b>	
	Ensure safe, environmentally responsible disposal of operating supplies and exchange parts. For this, locally provided recycling facilities and regulations must be utilized.

For disposal, the coupling parts must be separated where possible and sorted according to material type.



## **4 Technical description**

### **4.1 Characteristics**

- Proved and successful, simple design principle, safe dimensioning of all components.
- Idling speed is exactly determined by sufficiently dimensioned springs and can be varied as required.
- The coupling is compact, has a short design, is smooth, accident proof and maintenance low.
- The friction linings are sufficiently dimensioned of wear resistant and temperature resistant material and consequently have a very long life span.
- High thermic rating by intensive inner cooling.
- The design is cost effective, since it is easily adaptable to any applicational condition.





### **4.2 Specifications**

The specifications can be found in the catalogue and the dimensions in the installation drawing.

## 5 Mounting

### 5.1 General assembly instructions

Any work method which impairs the safety of the coupling is prohibited.  
The user undertakes to notify the manufacturer immediately of any changes occurring at the coupling which could impair safety (address see chapter 1).

<b>WARNING</b>	
	<p><b>Injuries can occur as a result of:</b></p> <ul style="list-style-type: none"> <li>▪ Contact with rotating parts</li> </ul> <p>Before starting work at the coupling, switch off the plant and secure against unintentional start-up.</p>
<b>WARNING</b>	
	<p><b>Injury and material damage can occur as a result of:</b></p> <ul style="list-style-type: none"> <li>▪ Assembly of the coupling in the wrong sequence</li> </ul> <p>Only ever assemble the coupling in the described sequence.</p>
<b>WARNING</b>	
	<p><b>Injury and material damage can occur as a result of:</b></p> <ul style="list-style-type: none"> <li>▪ Falling coupling components</li> </ul> <p>Secure coupling components against falling to the floor.</p>
<b>CAUTION</b>	
	<p><b>Material damage to coupling components can occur as a result of:</b></p> <ul style="list-style-type: none"> <li>▪ Contact with sharp-edged objects</li> </ul> <p>Protect coupling components for transportation. Only hoist coupling components with nylon belts or ropes. Always cushion parts when supporting them from below.</p>
<b>CAUTION</b>	
	<p><b>Material damage can occur as a result of:</b></p> <ul style="list-style-type: none"> <li>▪ Soiled joint surfaces</li> </ul> <p>The surfaces that are to be joined must be free of dirt, preservatives and lubricants.</p>

## CAUTION



**Material damage to coupling components can occur as a result of:**

- Anaerobic adhesives (e.g. Loctite) used for screw locking

This type of screw locking medium may not be in contact with rubber parts.



## IMPORTANT

- Screw preparation and tightening torque levels in accordance with CENTA data sheet D013-016 (see chapter 10.1).
- Use suitable lifting devices for assembly.
- The following assembly stages are described for coupling 0060-01400-VFCO.
- Part illustration and marking may differ slightly from installation drawing and delivery state.

## 5.2 Mounting the coupling

- Mount the coupling as appropriate for the type supplied.
  - Mounting the pre-assembled coupling when the bores (a) are accessible (see chapter 5.3).
  - Mounting the coupling in single parts when the bores (a) are not accessible (see chapter 5.4).

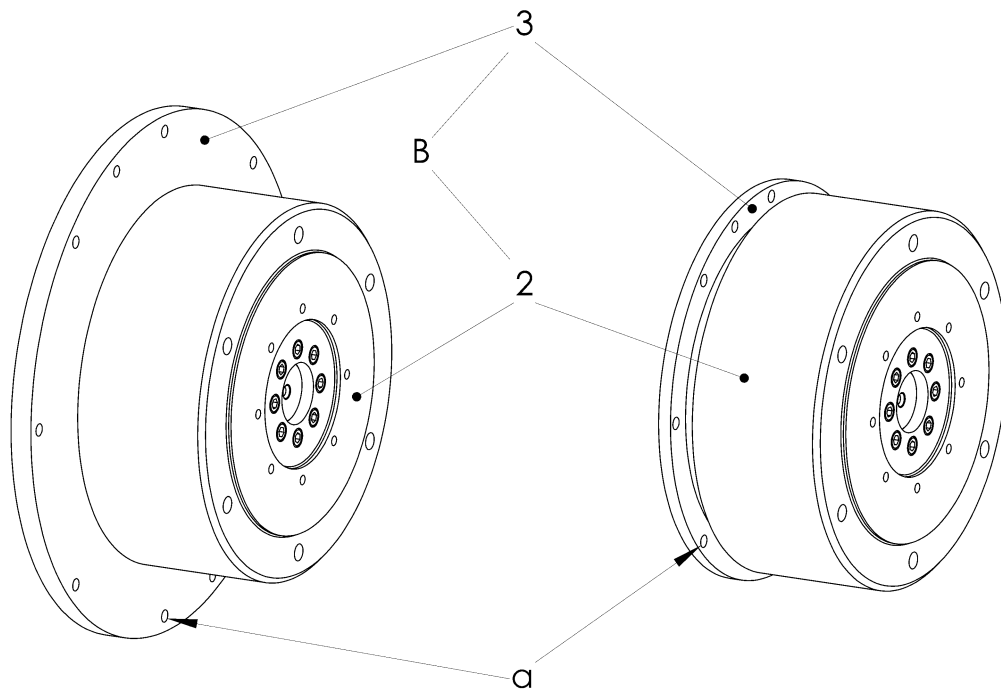

*Fig. 5-1 Bores accessible*

*Bores not accessible*

Item	Info	Designation	Remark
2		Pot	
3		Adapter	
B		Pre-mounted coupling	Pre-mounted by CENTA, see installation drawing
	a	Bore	In adapter (3)

### 5.3 Mounting the pre-mounted coupling to the flywheel

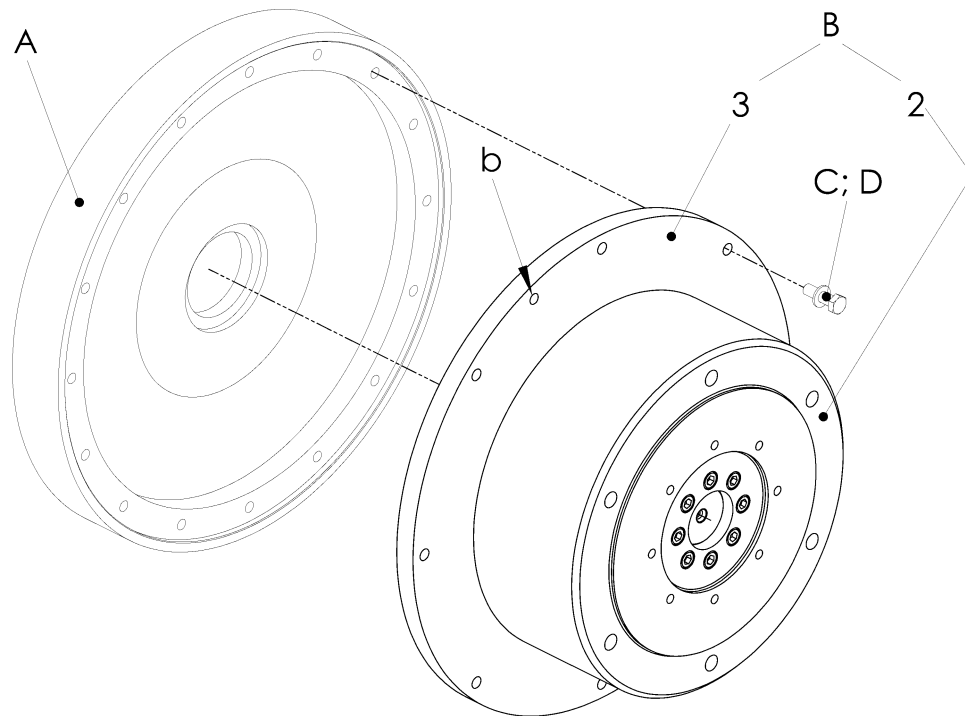

Fig. 5-2 Mounting the pre-mounted coupling to the flywheel

Item	Info	Designation	Remark
A		Flywheel	Customer part
B		Pre-mounted coupling	Pre-mounted by CENTA
C		Screw	Customer part
D		Washer	Customer part
	b	Forcing thread	(2x180°) for dismantling

- Push the pre-mounted coupling (B) into the centring of the flywheel (A).
- Screw the pre-mounted coupling (B) to the flywheel (A) using the screws (C) and the washers (D).

 **IMPORTANT**

Tightening torques for elements to connect couplings with customer parts could deviate from CENTA data sheet D013-016.  
 Consider specifications on installation drawing.



## 5.4 Mounting the coupling in single parts

### 5.4.1 Dismantling the pot

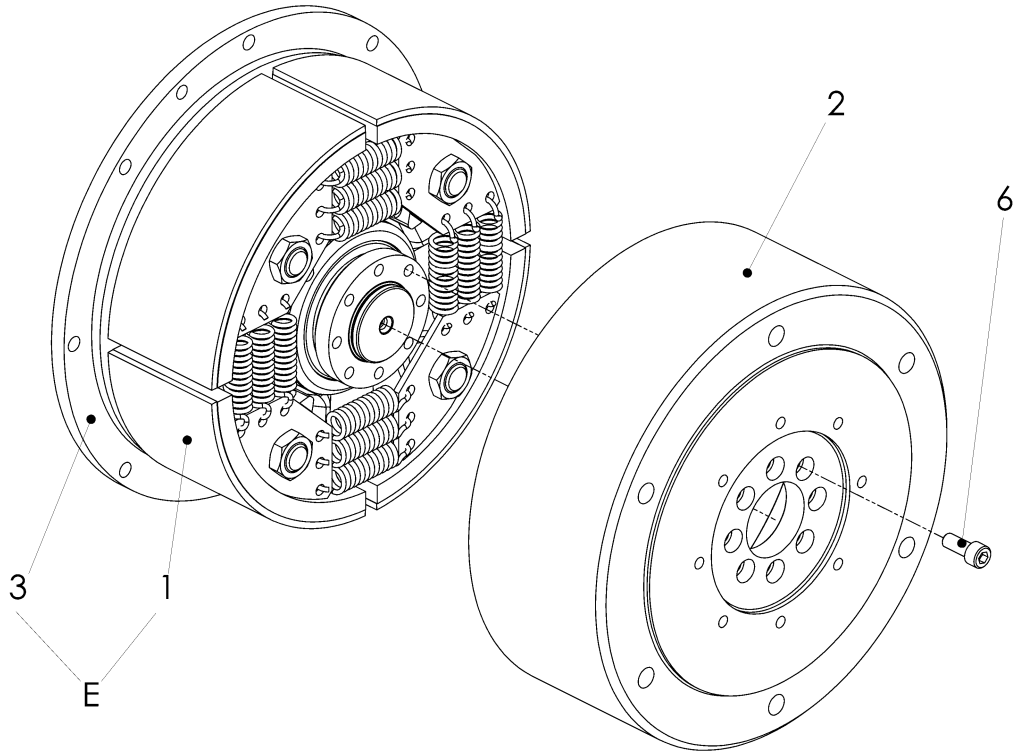

*Fig. 5-3 Dismantling the pot*

Item	Info	Designation	Remark
1		Assembly inner part	
2		Pot	
3		Adapter	
E		Pre-mounted assembly	Pre-mounted by CENTA
6		Screw ISO4762-10.9	

- Loosen and remove the screws (6) of the connection pot (2) and assembly inner part (1) and store temporarily for remounting.
- Pull the pot (2) off the centring of the assembly inner part (1) and store temporarily for remounting.

### 5.4.2 Mounting the assembly to the flywheel

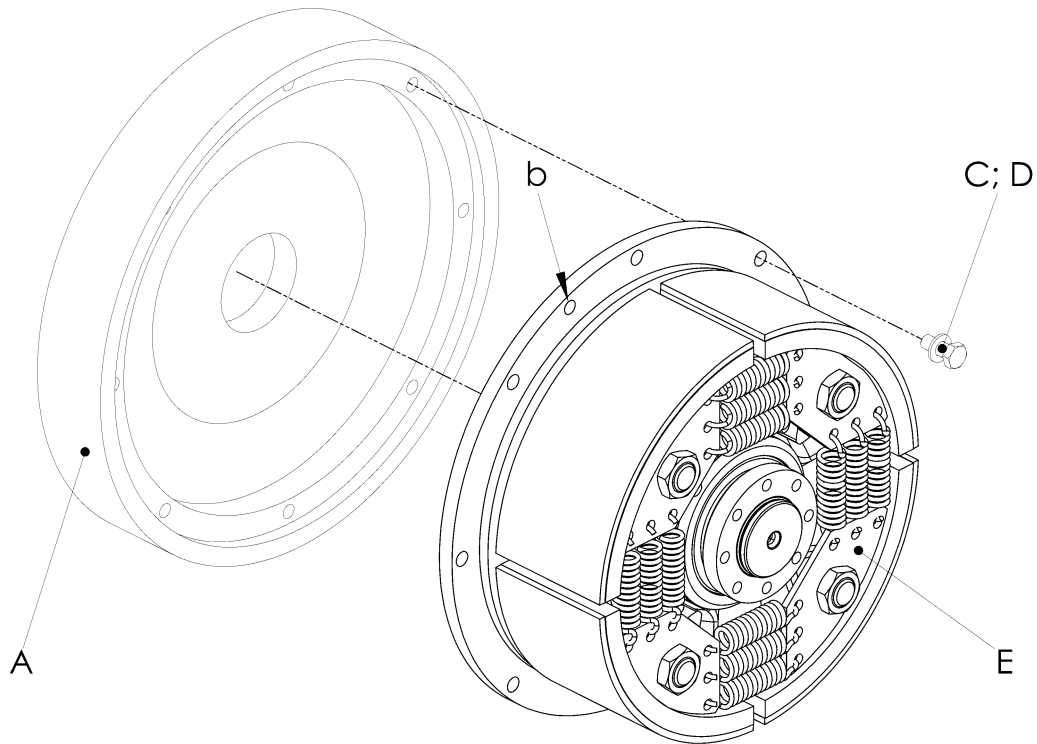

Fig. 5-4 Mounting the assembly to the flywheel

Item	Info	Designation	Remark
A		Flywheel	Customer part
C		Screw	Customer part
D		Washer	Customer part
E		Pre-mounted assembly	Pre-mounted by CENTA
	b	Forcing thread	(2x180°) for dismantling

- Push the pre-mounted assembly (E) into the centring of the flywheel (A).
- Screw the pre-mounted assembly (E) to the flywheel (A) using the screws (C) and the washers (D).

** IMPORTANT**

Tightening torques for elements to connect couplings with customer parts could deviate from CENTA data sheet D013-016.  
 Consider specifications on installation drawing.

### 5.4.3 Mounting the pot

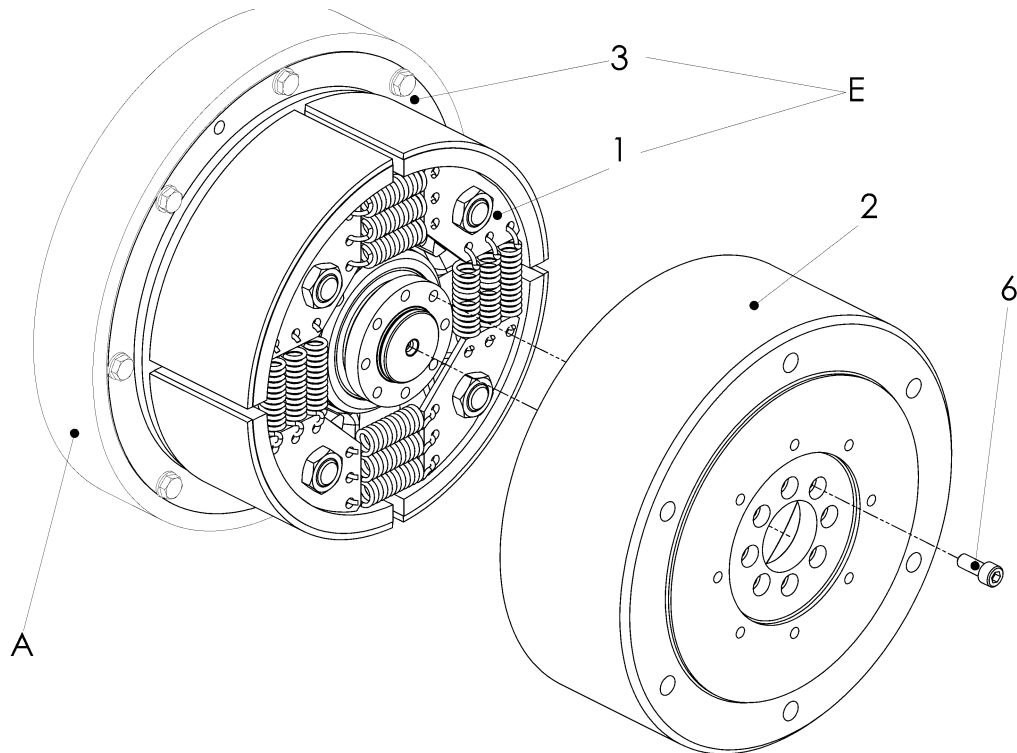

*Fig. 5-5 Mounting the pot*

Item	Info	Designation	Remark
1		Assembly inner part	
2		Pot	
3		Adapter	
6		Screw ISO4762-10.9	
A		Flywheel	Customer part
E		Pre-mounted assembly	Pre-mounted by CENTA

- Push the pot (2) onto the centring of the assembly inner part (1).
- Screw the pot (2) to the assembly inner part (1) using the screws (6).

## 5.5 Mounting the output drive to the coupling

- Mount the output drive as appropriate for the type supplied.
  - Mounting the output drive to couplings of type VFCO/VFSP, see chapter 5.5.1
  - Mounting the output drive to couplings of type VFG., see chapter 5.5.2
  - Mounting the output drive to couplings of type VFCL, see chapter 5.5.3

### 5.5.1 Mounting the output drive to couplings of type VFCO/VFSP

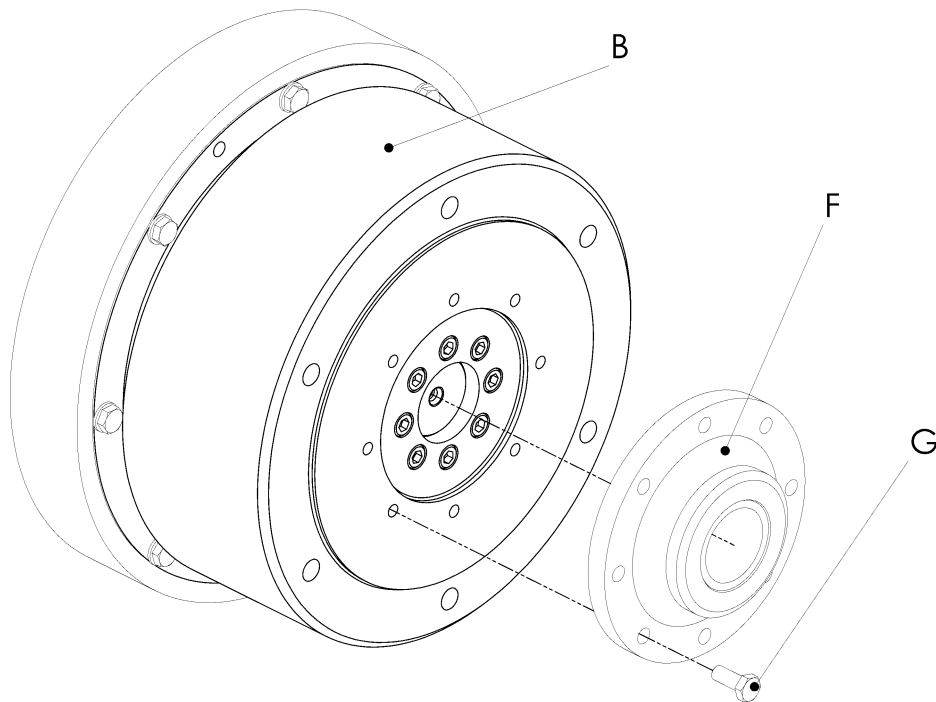

*Fig. 5-6 Mounting the output drive to couplings of type VFCO/VFSP*

Item	Info	Designation	Remark
B		Pre-mounted coupling	
F		Cardan shaft	
G		Screw	

- Push the cardan shaft (F) onto/into the centring of the pre-mounted coupling (B).
- Screw the cardan shaft (F) to the pre-mounted coupling (B) using the screws (G).

 **IMPORTANT**

Tightening torques for elements to connect couplings with customer parts could deviate from CENTA data sheet D013-016.  
Consider specifications on installation drawing.

**5.5.2 Mounting the output drive to couplings of type VFG.**

- Mount the driven side as described in the assembling instructions of the supplied coupling CENTAFLEX-A.

**5.5.3 Mounting the output drive to couplings of type VFCL**

- Mount the driven side as described in the assembling instructions of the supplied coupling CENTALINK.

**5.6 After completed mounting**

**WARNING**



**Injury and material damage can occur as a result of:**

- Loose screw connections

Before commissioning, the tightening torque levels of all screws must be checked and corrected if necessary.

Before commencing long-term operation, the plant must successfully complete a test run.

## 6 Operation

<b>WARNING</b>	
	<p><b>Injury and material damage can occur as a result of:</b></p> <ul style="list-style-type: none"> <li>▪ Worn coupling components</li> </ul> <p>If the running noises change and/or vibrations occur turn the plant off immediately.</p>

Determine the fault and its root cause, and remedy. The troubleshooting process is simplified by the table in the next chapter. On principle in case of a fault, an analysis of the entire plant should be performed.

### 6.1 Operating faults, root causes and remedy

<b>Prior to all kinds of remedies:</b>		<ul style="list-style-type: none"> <li>• Switch off the plant</li> <li>• Disconnect the driving and the driven units</li> </ul>
Faults	Possible root causes	Remedy
Running noises or vibrations in the unit	Loose screw connections	<ul style="list-style-type: none"> <li>• Check screw torque levels and correct if necessary</li> </ul>
	Damage of bearing	<ul style="list-style-type: none"> <li>• Replace the bearing</li> </ul>
Too high engaging speed due to wear	Friction linings of centrifugal weights or pot worn	<ul style="list-style-type: none"> <li>• Check the friction linings of the centrifugal weights</li> <li>• Check the pot</li> <li>• Replace worn parts</li> </ul>
The coupling does not produce the nominal torque	Friction surfaces are soiled with oil or grease	<ul style="list-style-type: none"> <li>• Clean the friction linings of the centrifugal weights</li> <li>• Clean the pot</li> </ul>
	Friction linings of centrifugal weights or pot worn	<ul style="list-style-type: none"> <li>• Check the friction linings of the centrifugal weights</li> <li>• Check the pot</li> <li>• Replace worn parts</li> </ul>
Coupling does not switch off	Springs are broken	<ul style="list-style-type: none"> <li>• Replace defective parts</li> </ul>
<b>After all remedies:</b>		<ul style="list-style-type: none"> <li>• Connect the driving and the driven units</li> <li>• Trial run</li> </ul>

*Table 6-1 Troubleshooting table*

In case of uncertainty or if you have questions, please contact our head office (address see chapter 1).

## 7 Care and maintenance

### WARNING



**Injuries can occur as a result of:**

- Contact with rotating parts

Before starting work at the coupling, switch off the plant and secure against unintentional start-up.

The coupling requires low maintenance. We recommend a visual inspection at the regular scheduled maintenance intervals for the whole unit.

### 7.1 Work to be performed

#### 7.1.1 Cleaning the coupling

- Remove any loose dirt from the coupling.

#### 7.1.2 Visual inspection of the coupling

- Inspect the coupling for cracks, chips or missing parts.
- Replace faulty and missing parts.

### 7.1.3 Checking thickness of friction linings

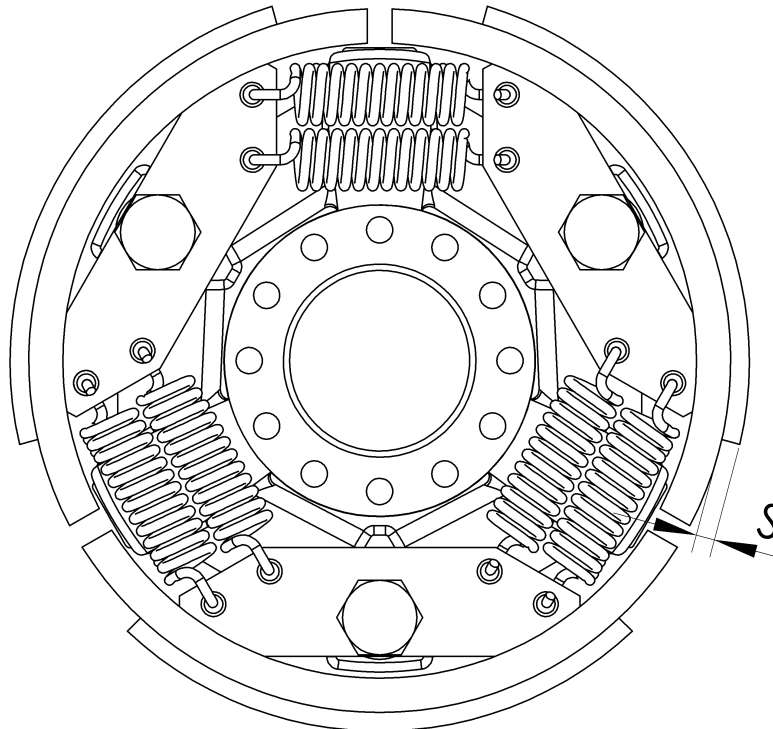

Fig. 7-1 Checking thickness of friction linings (example CS-400)

- Dismantling the driven unit (see chapter 8).
- Dismantling the pot (see chapter 8).
- Check the thickness (s) of the friction linings of the centrifugal weights at several spots.  
The centrifugal weights have to be replaced if the thickness of the friction linings is lower than the limit  $s_{min}$  (see table below).



#### **IMPORTANT**

Change of the centrifugal weights by service partner, if the thickness (s) of the friction linings is below the limit ( $s_{min}$ , see table below).  
Rubber element, friction linings of centrifugal weights, bolt springs and the hub are delivered pre-assembled as subassembly inner part.



#### 7.1.4 Check diameter of outer part

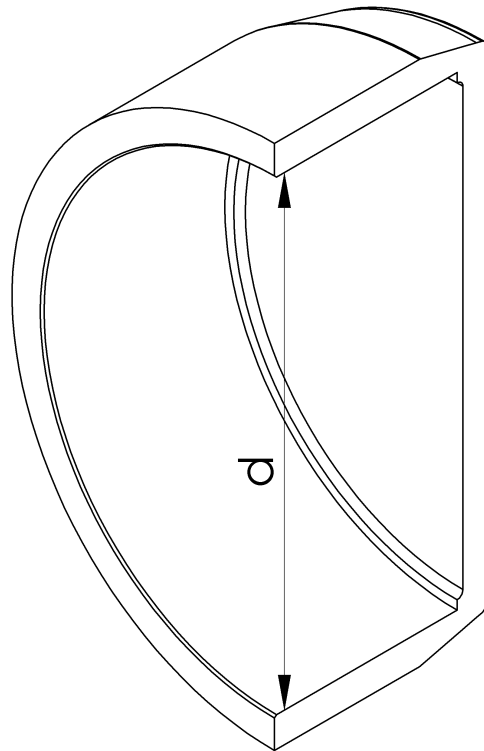

*Fig. 7-2 Check diameter of the outer part (example CS-400)*

- Check diameter (d) of the outer part at several spots.  
Exceeds the diameter (d) the value ( $d_{\min}$ , see table below), the outer part has to be replaced.



### **IMPORTANT**

Change of the outer part by service partner, if diameter is over limit ( $d_{\max}$ , see table below).



<b>CENTASTART Size</b>	<b>Thickness of friction linings <math>s_{min}</math> [mm]</b>	<b>Diameter of outer part <math>d_{max}</math> [mm]</b>
80	2,5	155 <sup>+1</sup>
180	2,5	182 <sup>+1</sup>
400	3,5	240 <sup>+1</sup>
600	3,5	240 <sup>+1</sup>
900	5,5	304 <sup>+1</sup>
1400	2,5	304 <sup>+1</sup>
2000	3,5	357 <sup>+1</sup>
2500	3,5	392 <sup>+1</sup>
5000	4,5	428 <sup>+1</sup>

Table 7-1 Thickness of friction linings and diameter of outer part

### 7.1.5 Inspection of the screw connections

- Check the tightening torque levels of all screws and if necessary, correct.

### 7.2 Replacing defective parts

- Remove the coupling as described in chapter 8.
- Replace wearing parts by service partner.
- Mount the coupling as described in chapter 5.

## 8 Dismantling

### 8.1 General dismantling instructions

Any work method which impairs the safety of the coupling is prohibited.  
The user undertakes to notify the manufacturer immediately of any changes occurring at the coupling which could impair safety (address see chapter 1).

#### **WICHTIG**

The coupling is dismantled in reverse order to the assembly process.  
Please refer to the illustrations in chapter 5.

#### **WARNING**



##### **Injuries can occur as a result of:**

- Contact with rotating parts

Before starting work at the coupling, switch off the plant and secure against unintentional start-up.

#### **WARNING**



##### **Injury and material damage can occur as a result of:**

- Dismantling of the coupling in the wrong sequence

Only ever dismantle the coupling in the described sequence.

#### **WARNING**



##### **Injury and material damage can occur as a result of:**

- Falling coupling components

Secure coupling components against falling to the floor.

#### **CAUTION**



##### **Material damage to coupling components can occur as a result of:**

- Contact with sharp-edged objects

Protect coupling components for transportation.

Only hoist coupling components with nylon belts or ropes.

Always cushion parts when supporting them from below.

#### **IMPORTANT**

Use suitable lifting devices for dismantling.

## **8.2 Dismantling the output drive from the coupling**

- Dismantling the output drive from the couplings type VFCO/VFSP see chapter 8.2.1
- Dismantling the output drive from the couplings type VFG. see chapter 8.2.2
- Dismantling the output drive from the couplings type VFCL see chapter 8.2.3

### **8.2.1 Dismantling the output drive from the couplings type VFCO/VFSP**

**See Fig. 5-7:**

- Loosen the screws (G) of the connection cardan shaft (F) and pre-mounted coupling (B) and remove.
- Pull the cardan shaft (F) out of/off the centring of the pre-mounted coupling (B) and remove.

### **8.2.2 Dismantling the output drive from the couplings type VFG.**

- Dismantle the output drive as described in the assembling instructions of the supplied coupling CENTAFLEX-A.

### **8.2.3 Dismantling the output drive from the couplings type VFCL**

- Dismantle the output drive as described in the assembling instructions of the supplied coupling CENTALINK.

## **8.3 Dismantling the pot (if necessary)**

**See Fig. 5-6:**

- Loosen the screws (6) of the connection pot (2) and assembly inner part (1) of the pre-mounted assembly (E) and remove.
- Pull the pot (2) off the centring of the assembly inner part (1) and remove.

## **8.4 Dismantling the pre-mounted coupling/assembly from the flywheel**

**See Fig. 5-3 or 5-5:**

- Loosen the screws (C) of the connection pre-mounted coupling/pre-mounted assembly (B/E) and flywheel (A) and remove with the washers (D).
- Insert one screw into each forcing thread (b; 2x180°).
- By the aid of the screws in the forcing threads (b) press out the pre-mounted coupling/pre-mounted assembly (B/E) of the centring of the flywheel (A) and remove.
- Remove the screws from the forcing threads (b).

## 8.5 Dismantling the assembly inner part from the adapter (if necessary)

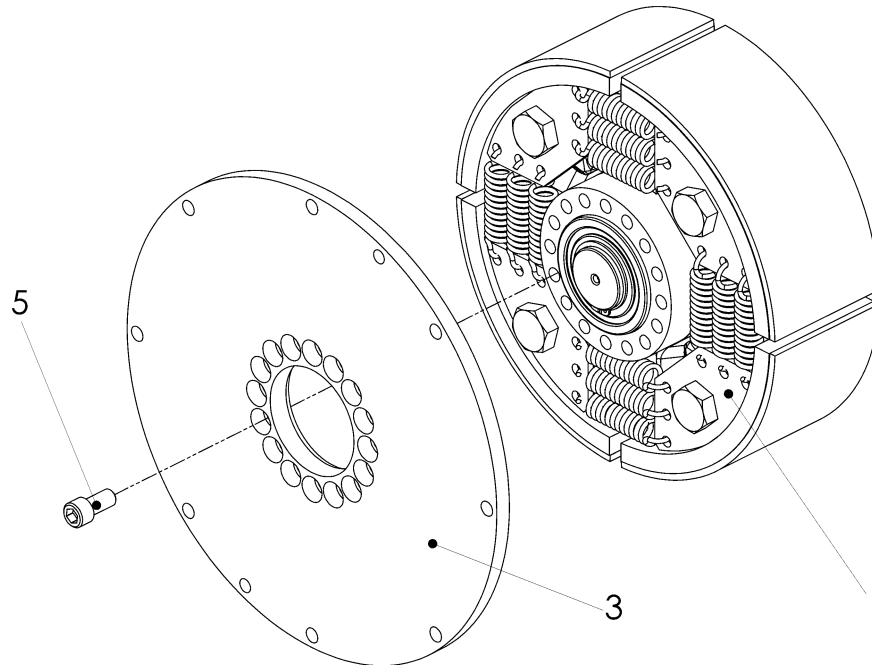

Fig. 8-1 Dismantling the assembly inner part from the adapter

Item	Info	Designation	Remark
1		Assembly inner part	
3		Adapter	
5		Screw ISO4762-10.9	<b>T<sub>A</sub></b> see installation drawing

- Loosen the screws (5) of the connection adapter (3) and assembly inner part (1) and remove.
- Pull the adapter (3) off the centring of the assembly inner part (1) and remove.

### 8.5.1 Mounting the pre-mounted assembly inner part to the adapter

**See Fig. 8-1:**

- Push the adapter (3) onto the centring of the assembly inner part (1).
- Screw the adapter (3) to the assembly inner part (1) using the screws (5). Specified tightening torque **T<sub>A</sub>** see installation drawing.

## 8.6 Reassembling the coupling

- Reassemble the coupling as described in chapter 5.

## 9 Wearing and spare parts

### WARNING



**Injury and material damage can occur as a result of:**

- Mounting and/or utilization of non-original CENTA parts  
Never use parts from other manufacturers.

A stock of the most important wearing and spare parts is the most important condition to ensure that the coupling is functional and ready for operation at all times.

We only provide a warranty for CENTA original parts.

Wearing parts of this coupling:

- Rubber element, bearing, friction linings of centrifugal weights and bolt springs. These are delivered pre-mounted as assembly inner part.
- Pot

When exchanging, all screw connections must be renewed. These must be ordered separately.

When ordering a spare, specify:

- Order no.
- Coupling order no.
- Drawing no.



## 10 Annex

### 10.1 CENTA data sheet D013-016 (unlubricated screw connections)

**Validity:**

For all non-dynamically stressed screw connections with **not lubricated** shank bolts in accordance with ISO 4014, ISO 4017 and ISO 4762 (DIN 912) with metric standard thread in accordance with DIN ISO 262, unless other specifications are given on CENTA documents.

**Preparation of parts that are to be screwed together:**

The joining areas must be free of dirt, preservatives and lubricants.

**Preparation of screws that ARE NOT secured with liquid screw locking medium:**

Use screws as delivered.

**Preparation of screws that ARE secured with liquid screw locking medium:**

Remove all grease from the thread.

**Screw tightening method:**

Screw in (by hand with torque wrench).

d	Thread size			d	Thread size		
	Strength class	Tightening torques			Strength class	Tightening torques	
		[Nm] ±5%	[in lbs] ±5%			[Nm] ±5%	[in lbs] ±5%
M6	8.8	10	90	M22	8.8	470	4160
	10.9	14	125		10.9	670	5930
	12.9	17	150		12.9	780	6900
M8	8.8	23	205	M24	8.8	600	5310
	10.9	34	300		10.9	850	7520
	12.9	40	350		12.9	1000	8850
M10	8.8	46	410	M27	8.8	750	6640
	10.9	68	600		10.9	1070	9470
	12.9	79	700		12.9	1250	11060
M12	8.8	79	700	M30	8.8	1000	8850
	10.9	117	1050		10.9	1450	12830
	12.9	135	1200		12.9	1700	15050
M14	8.8	125	1100	M33	8.8	1400	12400
	10.9	185	1650		10.9	1950	17250
	12.9	215	1900		12.9	2300	20350
M16	8.8	195	1725	M36	8.8	1750	15500
	10.9	280	2500		10.9	2500	22150
	12.9	330	2900		12.9	3000	26550
M18	8.8	245	2200	M39	8.8	2300	20350
	10.9	350	3100		10.9	3300	29200
	12.9	410	3600		12.9	3800	33650
M20	8.8	350	3100				
	10.9	490	4350				
	12.9	580	5150				



**10.2 CENTA data sheet D006-900**  
**Declaration of incorporation according to the EC Machinery Directive 2006/42/EC, Appendix II B**

Manufacturer:

**CENTA Antriebe**  
**Kirschey GmbH**  
Bergische Strasse 7  
42781 Haan / GERMANY

Contact:

Phone +49-2129-912-0  
Fax +49-2129-2790  
centa@centa.de  
www.centa.info

We herewith declare that the **incomplete** machine

Product: CENTASTART-Coupling

Model / series code: CS / 0060

Installation size: 80...5000

Design: all

Serial number: according to shipping documents, if applicable

- provided this is possible as far as the scope of supply is concerned - complies with the following basic requirements of the **Machinery Directive 2006/42/EC** Appendix I, subchapters 1.1.2, 1.1.3, 1.1.5, 1.3.2, 1.3.3, 1.3.4 und 1.5.4.

In addition, we declare that the special technical documents for this incomplete machine were compiled according to Appendix VII Part B and undertake to forward these to the market monitoring authorities by request via our "Documentation Department".

Commissioning of the incomplete machine is interdicted until the incomplete machine has been incorporated in a machine and the latter complies with the provisions of the EC Machinery Directive and the EC Declaration of Conformity according to Appendix II A is on hand.

The declaration is invalidated by every modification to the delivered parts.

Authorised representative for the compilation of the relevant technical documents:

*i.A. G. Anderseck*

by order of Gunnar Anderseck  
(Authorised Person Documentation)

Declaration of incorporation was issued:

*i.v. J. Exner*

by proxy Dipl.-Ing. Jochen Exner  
(Design Management)

Haan, 11.12.2009