

VULKARDAN L&P

TECHNISCHE DATEN TECHNICAL DATA





SCAN →



Bitte benutzen Sie Ihr Smartphone mit der entsprechenden Software, scannen Sie den QR-Code ein.

Please use your smartphone with the relevant software, scan the QR-Code.

GET INFO →



Sie erhalten die Information, ob dies die aktuellste Version ist.
You will get the information whether you have got the latest version.



07/2019

Das Handsymbol kennzeichnet Seiten, auf denen es eine Veränderung zur Vorgängerversion gibt.
The hand symbol appears on pages which differ from the previous catalogue version.

INHALT CONTENTS

Eigenschaften VULKARDAN L	04	Characteristics VULKARDAN L	04
Baureihenübersicht VULKARDAN L	06	Summary of Series VULKARDAN L	06
Technische Daten VULKARDAN L	08	Technical Data VULKARDAN L	08
Leistungsdaten	08	Performance Data	08
Geometrische Daten	10	Geometric Data	10
Baureihe 1640/1, 1640/2	10	Series 1640/1, 1640/2	10
Baureihe 1660/1, 1660/2	12	Series 1660/1, 1660/2	12
Baureihe 1680/1, 1680/2	14	Series 1680/1, 1680/2	14
Baureihe 1690/1, 1690/2	16	Series 1690/1, 1690/2	16
Eigenschaften VULKARDAN P	18	Characteristics VULKARDAN P	18
Benötigte Gelenkwellendaten zur Überprüfung des zulässigen Beugungswinkels	20	Cardan shaft data required for the permissible deflection angle	20
Erläuterungen des Productcodes	21	Explanations of the Product Code	21
Online-Service	22	Online-Service	22
Gültigkeitsklausel	23	Validity Clause	23



VULKARDAN L

EIGENSCHAFTEN CHARACTERISTICS

DREHMOMENT TORQUE

0.16 kNm – 12.50 kNm

EINSATZGEBIETE

Elastisch aufgestellte Anlagen.

Die hochelastischen Kupplungen VULKARDAN L wurden speziell als Vorschaltkupplungen für Gelenkwellen entwickelt. Die Hauptkonstruktionsteile der Elastomerkupplungen sind die hochelastischen Elemente und die gegeneinander abgestützten Innen- und Aussenteile der hochelastischen Kupplung. Die Elemente weisen eine hohe Drehelastizität und eine gute Dämpfung auf. Zusätzliche Dämpfung wird aus der Lagerung gewonnen.

Wenn angetriebene Anlagen nicht zum Motor ausgerichtet sind oder lange Distanzen überbrückt werden müssen, werden üblicherweise Gelenkwellen eingesetzt. Ist das antreibende Aggregat ein Dieselmotor dient zusätzlich eine hochelastische Kupplung dazu, Resonanzpunkte aus dem Arbeitsbereich des Systems herauszuhalten. Die Kupplung schützt damit den Antriebsstrang und angeschlossene Aggregate vor unzulässigen Wechsellmomenten.

PRODUKTVORTEILE

- ⊕ Maßgeschneidert für den Einsatz als Vorschaltkupplung bei Gelenkwellen
- ⊕ Die Lagerung nimmt die Gewichte der Gelenkwelle und die von ihr erzeugten Kräfte auf
- ⊕ Niedrige Betriebskosten durch wartungsfreie Komponenten wie Gleitlager

AREAS OF APPLICATION

Flexibly mounted engines.

The highly flexible VULKARDAN L couplings have been specifically developed for application in conjunction with Cardan shafts. The main components of the VULKARDAN L coupling are the highly flexible element and the inner and outer couplings parts supported against each other. The elements have a high torsional flexibility and good damping properties. On to the support additional damping is achieved.

When the driven machine is not in line with the prime mover or when long distances have to be bridged, Cardan shafts are used. With a diesel engine as the prime mover, a highly flexible coupling will be required for shifting resonances and damping of torsional vibration. This coupling protects the Cardan shaft and the driven machinery from inadmissible vibratory loads.

PRODUCT BENEFITS

- ⊕ Customised for use as a clutch in Cardan shafts
- ⊕ The bearing absorbs the weights of the Cardan shaft and the forces generated by it
- ⊕ Lower operating costs as a result of maintenance-free components such as the sliding bearing

VULKARDAN L

BAUREIHENÜBERSICHT SUMMARY OF SERIES

1640/1, 1640/2

BAUREIHE SERIES

Seite 10 Page 10

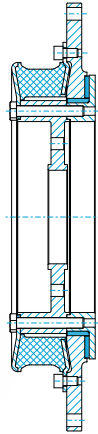

Zur Verbindung eines Schwungrades oder Ähnlichem mit einer Gelenkwelle.
Kurze Einbaulänge mit zwei verschiedenen Gelenkwellenanschlüssen (1./2). Gelenkwelle und Kupplung sollen zusammengebaut montiert werden.

For connecting a flywheel or similar to a Cardan shaft.
Short installation length with two different Cardan shaft connection diameters (1./2). The Cardan shaft and coupling must be installed as a unit.

Baugruppe Dimension Group	K 1710 – K 5010
Nennmoment Nominal Torque	0.16 kNm – 6.30 kNm

1660/1, 1660/2

BAUREIHE SERIES

Seite 12 Page 12

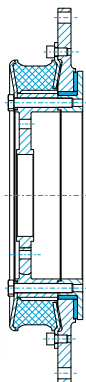

Zur Verbindung eines Schwungrades oder Ähnlichem mit einer Gelenkwelle.
Außenliegender Gelenkwellenanschluss in zwei verschiedenen Durchmessern (1./2). Gelenkwelle und Kupplung können getrennt eingebaut werden.

For connecting a flywheel or similar to a Cardan shaft.
External Cardan shaft connection with two different diameters (1./2). The Cardan shaft and coupling can be installed individually.

Baugruppe Dimension Group	K 1710 – K 5810
Nennmoment Nominal Torque	0.16 kNm – 12.50 kNm

1680/1, 1680/2 BAUREIHE SERIES

Seite 14 Page 14

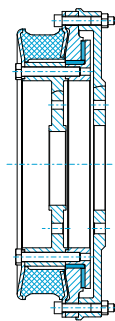

Zur Verbindung eines Flansches mit einer Gelenkwelle.

Kurze Einbaulänge mit zwei verschiedenen Gelenkwellenanschlüssen ($\sqrt{1,2}$). Gelenkwelle und Kupplung sollen innenteilseitig montiert werden.

For connecting a flywheel with a Cardan shaft.

Short installation length with two different Cardan shaft connection diameters ($\sqrt{1,2}$). The Cardan shaft and coupling should at innerpartside be installed as a unit.

Baugruppe Dimension Group	K 1710 – K 5010
Nenn Drehmoment Nominal Torque	0.16 kNm – 6.30 kNm

1690/1, 1690/2 BAUREIHE SERIES

Seite 16 Page 16

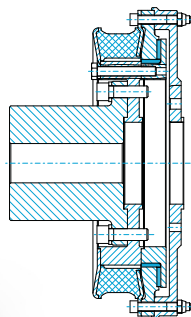
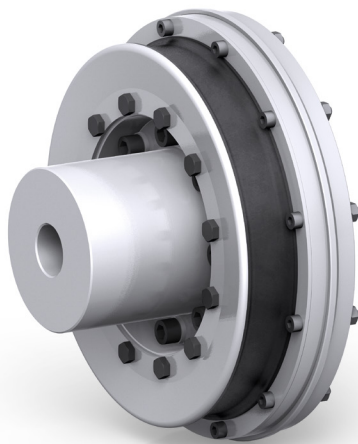

Zur Verbindung einer Welle mit einer Gelenkwelle.

Gelenkwelle und Kupplung können getrennt eingebaut werden.

For connecting a shaft with a Cardan shaft.

Cardan shaft and coupling can be installed individually.

Baugruppe Dimension Group	K 1710 – K 5010
Nenn Drehmoment Nominal Torque	0.16 kNm – 6.30 kNm

VULKARDAN L

LEISTUNGSDATEN PERFORMANCE DATA

Kupplungstyp Type of Coupling		T_{KN}	T_{Kmax1}	T_{Kmax2}	T_{KW}	P_{KV30}	n_{Kmax}	$C_{Tdyn}^{1)2)}$	$\psi^{1)2)}$
		[kNm]	[kNm]	[kNm]	[kNm]	[kW]	[1/min]	[kNm/rad] nominal	nominal
Größe Size	Baugruppe Dimension Group	Nenn Drehmoment Nominal Torque	Max. Drehmoment ₁ Max. Torque ₁	Max. Drehmoment ₂ Max. Torque ₂	Wechsel- drehmoment Vibratory Torque	Verlustleistung Power Loss	Drehzahl Rotational Speed	Dynamische Drehfedersteife Dynamic Torsional Stiffness	Verhältnismäßige Dämpfung Relative Damping
K 1714	K1710	0,16	0,24	0,58	0,06	0,15	6350	0,7	1,60
K 1711	K1710	0,16	0,24	0,58	0,06	0,15	6350	0,9	1,60
K 1715	K1710	0,20	0,30	0,72	0,06	0,15	6350	1,5	1,60
K 1712	K1710	0,20	0,30	0,72	0,06	0,15	6350	2,0	1,60
K 1914	K1910	0,25	0,38	0,90	0,10	0,17	5550	1,1	1,60
K 1911	K1910	0,25	0,38	0,90	0,10	0,17	5550	1,4	1,60
K 1915	K1910	0,31	0,47	1,12	0,10	0,17	5550	2,4	1,60
K 1912	K1910	0,31	0,47	1,12	0,10	0,17	5550	3,2	1,60
K 2114	K2110	0,40	0,60	1,44	0,16	0,20	4900	1,7	1,60
K 2111	K2110	0,40	0,60	1,44	0,16	0,20	4900	2,2	1,60
K 2115	K2110	0,50	0,75	1,80	0,16	0,20	4900	3,8	1,60
K 2112	K2110	0,50	0,75	1,80	0,16	0,20	4900	5,2	1,60
K 2514	K2510	0,63	0,95	2,27	0,25	0,23	4200	2,6	1,60
K 2511	K2510	0,63	0,95	2,27	0,25	0,23	4200	3,5	1,60
K 2515	K2510	0,80	1,20	2,88	0,25	0,23	4200	6,0	1,60
K 2512	K2510	0,80	1,20	2,88	0,25	0,23	4200	8,2	1,60
K 2914	K2910	1,00	1,50	3,60	0,40	0,29	3550	4,1	1,60
K 2911	K2910	1,00	1,50	3,60	0,40	0,29	3550	5,5	1,60
K 2915	K2910	1,25	1,88	4,50	0,40	0,29	3550	9,4	1,60
K 2912	K2910	1,25	1,88	4,50	0,40	0,29	3550	13,0	1,60
K 3414	K3410	1,60	2,40	5,76	0,64	0,33	3000	6,6	1,60
K 3411	K3410	1,60	2,40	5,76	0,64	0,33	3000	8,8	1,60
K 3415	K3410	2,00	3,00	7,20	0,64	0,33	3000	15,0	1,60
K 3412	K3410	2,00	3,00	7,20	0,64	0,33	3000	21,0	1,60
K 4114	K4110	2,50	3,75	9,00	1,00	0,43	2500	10,0	1,60
K 4111	K4110	2,50	3,75	9,00	1,00	0,43	2500	13,5	1,60
K 4115	K4110	3,10	4,65	11,16	1,00	0,43	2500	23,0	1,60
K 4112	K4110	3,10	4,65	11,16	1,00	0,43	2500	32,0	1,60

Siehe Erläuterung der Technischen Daten

Für eine genaue Überprüfung der zulässigen Beugwinkel benötigt VULKAN die technischen Daten der Gelenkwelle. Siehe Seite 20.

- VULKAN empfiehlt die zusätzliche Berücksichtigung von $C_{Tdyn\ warm}$ (0,7), $C_{Tdyn\ la}$ (1,35) und ψ_{warm} (0,7) für die Berechnung der Drehschwingungen in der Anlage.
- Der Betriebszustand der Anlage kann eine Korrektur der gegebenen Werte notwendig machen. Durch die Eigenschaft des Werkstoffs Gummi sind Toleranzen der aufgeführten Daten für C_{Tdyn} von 0% bis 30% für 4-Elemente bzw. von -20% bis 10% für 1-, 5-, und 2-Elemente möglich. Für ψ sind Toleranzen von -20% bis 10% möglich.

See Explanation of the Technical Data

For a validation of the permissible bending angle the technical data of the joint shaft are necessary. See page 20.

- VULKAN recommends additionally taking into account $C_{Tdyn\ warm}$ (0,7), $C_{Tdyn\ la}$ (1,35) and ψ_{warm} (0,7) for calculating the torsional vibration in the system.
- The operating state of the system can make it necessary to correct the values given. Due to the properties of rubber tolerances in the technical data of 0% up to 30% for 4-elements, -20% up to 10% for 1-, 5- and 2-elements for C_{Tdyn} are possible. For ψ tolerances of -20% up to 10% are possible.

LEISTUNGSDATEN PERFORMANCE DATA

Kupplungstyp Type of Coupling		T_{KN}	T_{Kmax1}	T_{Kmax2}	T_{KW}	P_{KV30}	n_{Kmax}	$C_{Tdyn}^{1)}$	$\psi^{2)}$
		[kNm]	[kNm]	[kNm]	[kNm]	[kW]	[1/min]	[kNm/rad] nominal	nominal
Größe Size	Baugruppe Dimension Group	Nenn Drehmoment Nominal Torque	Max. Drehmoment ₁ Max. Torque ₁	Max. Drehmoment ₂ Max. Torque ₂	Wechsel- drehmoment Vibratory Torque	Verlustleistung Power Loss	Drehzahl Rotational Speed	Dynamische Drehfedersteife Dynamic Torsional Stiffness	Verhältnismäßige Dämpfung Relative Damping
K 4514	K4510	3,15	4,73	11,34	1,26	0,47	2300	13,0	1,60
K 4511	K4510	3,15	4,73	11,34	1,26	0,47	2300	17,0	1,60
K 4515	K4510	4,00	6,00	14,40	1,26	0,47	2300	29,0	1,60
K 4512	K4510	4,00	6,00	14,40	1,26	0,47	2300	41,0	1,60
K 4814	K4810	4,00	6,00	14,40	1,60	0,47	2300	16,5	1,60
K 4811	K4810	4,00	6,00	14,40	1,60	0,47	2300	22,0	1,60
K 4815	K4810	5,00	7,50	18,00	1,60	0,47	2300	37,5	1,60
K 4812	K4810	5,00	7,50	18,00	1,60	0,47	2300	52,0	1,60
K 5014	K5010	5,00	7,50	18,00	2,00	0,57	2000	20,0	1,60
K 5011	K5010	5,00	7,50	18,00	2,00	0,57	2000	27,0	1,60
K 5015	K5010	6,30	9,45	22,68	2,00	0,57	2000	46,0	1,60
K 5012	K5010	6,30	9,45	22,68	2,00	0,57	2000	64,0	1,60
K 5814	K5810	10,00	15,00	36,00	4,00	0,49	1800	29,9	1,60
K 5811	K5810	10,00	15,00	36,00	4,00	0,49	1800	38,2	1,60
K 5815	K5810	12,50	18,75	45,00	4,00	0,49	1800	62,0	1,60
K 5812	K5810	12,50	18,75	45,00	4,00	0,49	1800	74,4	1,60

Siehe Erläuterung der Technischen Daten

Für eine genaue Überprüfung der zulässigen Beugewinkel benötigt VULKAN die technischen Daten der Gelenkwelle. Siehe Seite 20.

- VULKAN empfiehlt die zusätzliche Berücksichtigung von $C_{Tdyn\ warm}$ (0,7), $C_{Tdyn\ la}$ (1,35) und ψ_{warm} (0,7) für die Berechnung der Drehschwingungen in der Anlage.
- Der Betriebszustand der Anlage kann eine Korrektur der gegebenen Werte notwendig machen. Durch die Eigenschaft des Werkstoffs Gummi sind Toleranzen der aufgeführten Daten für C_{Tdyn} von 0% bis 30% für 4-Elemente bzw. von -20% bis 10% für 1-, 5-, und 2-Elemente möglich. Für ψ sind Toleranzen von -20% bis 10% möglich.

See Explanation of the Technical Data

For a validation of the permissible bending angle the technical data of the joint shaft are necessary. See page 20.

- VULKAN recommends additionally taking into account $C_{Tdyn\ warm}$ (0,7), $C_{Tdyn\ la}$ (1,35) and ψ_{warm} (0,7) for calculating the torsional vibration in the system.
- The operating state of the system can make it necessary to correct the values given. Due to the properties of rubber tolerances in the technical data of 0% up to 30% for 4-elements, -20% up to 10% for 1-, 5- and 2-elements for C_{Tdyn} are possible. For ψ tolerances of -20% up to 10% are possible.



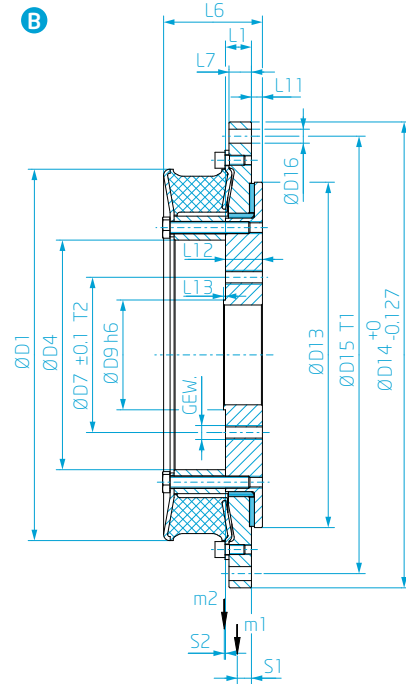
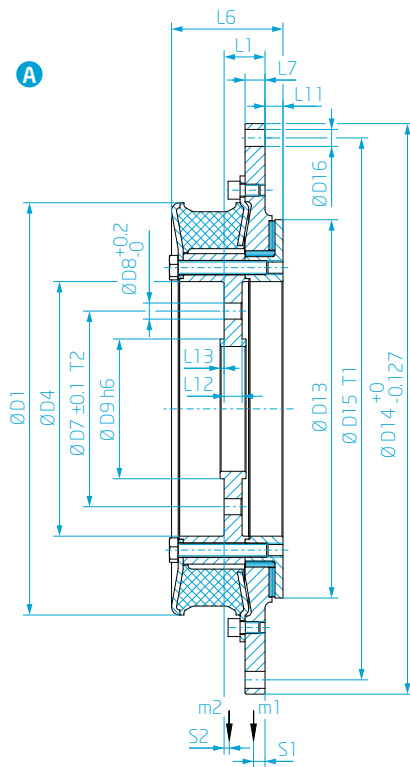

GEOMETRISCHE DATEN GEOMETRIC DATA

Baugruppe Dimension Group	Schwungrad Flywheel	Gelenkwellenanschluss Cardan shaft connection	Abbildung Figure	Abmessungen Dimension									
				D_1 [mm]	D_4 [mm]	D_7 [mm]	T_2 [-] Teilung/holes	GEW. [mm]	D_8 [mm]	D_9 [mm]	D_{13} [mm]	D_{14} [mm]	
	SAEJ620												
	[°]												
K 1710	8	1	A	150,0	80,0	52,0	4	-	6,1	35,0	147,0	263,5	
K 1710	8	2	A	150,0	80,0	62,0	6	-	6,1	42,0	147,0	263,5	
K 1910	8	1	A	172,0	95,0	62,0	6	-	6,1	42,0	166,0	263,5	
K 1910	8	2	A	172,0	95,0	74,5	4	-	8,1	47,0	166,0	263,5	
K 2110	8	1	A	195,0	105,0	74,5	4	-	8,1	47,0	192,0	263,5	
K 2110	8	2	A	195,0	105,0	84,0	6	-	8,1	57,0	192,0	263,5	
K 2510	8	1	A	225,0	125,0	84,0	6	-	8,1	57,0	208,0	263,5	
K 2510	8	2	A	225,0	125,0	101,5	8	-	10,1	75,0	208,0	263,5	
K 2510	11½	1	A	225,0	125,0	84,0	6	-	8,1	57,0	208,0	352,4	
K 2510	11½	2	A	225,0	125,0	101,5	8	-	10,1	75,0	208,0	352,4	
K 2910	11½	1	A	269,0	155,0	101,5	8	-	10,1	75,0	262,0	352,4	
K 2910	11½	2	A	269,0	155,0	130,0	8	-	12,1	90,0	262,0	352,4	
K 3410	11½	1	A	313,0	185,0	130,0	8	-	12,1	90,0	290,0	352,4	
K 3410	11½	2	B	313,0	185,0	155,5	8	M14	-	110,0	290,0	352,4	
K 3410	14	1	A	313,0	185,0	130,0	8	-	12,1	90,0	290,0	466,7	
K 3410	14	2	B	313,0	185,0	155,5	8	M14	-	110,0	290,0	466,7	
K 4110	14	1	B	372,0	230,0	155,5	8	M14	-	110,0	346,0	466,7	
K 4110	14	2	B	372,0	230,0	196,0	8	M16	-	140,0	346,0	466,7	
K 4510	14	1	A	413,0	255,0	196,0	8	-	16,1	140,0	379,0	466,7	
K 4510	14	2	A	413,0	255,0	218,0	8	-	18,1	140,0	379,0	466,7	
K 4810	14	1	A	417,0	228,0	155,5	8	-	14,1	110,0	383,0	466,7	
K 4810	14	2	B	417,0	228,0	196,0	8	M16	-	140,0	383,0	466,7	
K 5010	18	1	A	476,0	290,0	218,0	8	-	18,1	140,0	444,0	571,5	
K 5010	18	2	A	476,0	290,0	245,0	8	-	20,1	175,0	444,0	571,5	



Abmessungen Dimension									Massenträgheitsmomente Mass moments of inertia		Masse Mass		Schwerpunktsabstand Distance to center of gravity	
D ₁₅	T ₁	D ₁₆	L ₁	L ₆	L ₇	L ₁₁	L ₁₂	L ₁₃	J ₁	J ₂	m ₁	m ₂	S ₁	S ₂
[mm]	[-] Teilung/holes	[mm]	[mm]	[mm]	[mm]	[mm]	[mm]	[mm]	[kgm ²]	[kgm ²]	[kg]	[kg]	[mm]	[mm]
244,5	6	11,0	15,0	43,7	8,0	10,0	6,0	1,2	0,03	0,01	3,2	1,9	4,1	3,7
244,5	6	11,0	15,0	43,7	8,0	10,0	6,0	1,5	0,03	0,01	3,2	2,0	4,1	3,7
244,5	6	11,0	19,0	51,1	11,0	10,0	8,0	1,5	0,04	0,01	4,0	2,8	-	-
244,5	6	11,0	19,0	51,1	11,0	10,0	8,0	2,0	0,04	0,01	4,0	2,8	-	-
244,5	6	11,0	22,0	56,2	14,0	9,0	8,0	2,0	0,06	0,02	5,8	5,1	10,8	0,1
244,5	6	11,0	22,0	56,2	14,0	9,0	8,0	2,0	0,06	0,02	5,8	5,1	10,8	0,1
244,5	6	11,0	28,0	63,6	20,0	8,0	10,0	2,0	0,06	0,04	5,3	5,9	10,1	6,8
244,5	6	11,0	28,0	63,6	20,0	8,0	10,0	2,0	0,06	0,04	5,3	5,9	10,1	6,8
333,4	8	11,0	28,0	63,6	10,0	8,0	10,0	2,0	0,15	0,04	8,9	5,9	8,3	6,7
333,4	8	11,0	28,0	63,6	10,0	8,0	10,0	2,0	0,15	0,04	8,9	5,9	8,3	6,0
333,4	8	11,0	25,0	76,4	12,0	17,0	12,0	2,0	0,17	0,09	9,0	10,1	6,1	5,1
333,4	8	11,0	25,0	76,4	12,0	17,0	12,0	2,0	0,17	0,09	9,0	10,1	6,1	5,1
333,4	8	11,0	40,0	87,6	28,0	8,0	14,0	2,0	0,23	0,17	10,3	14,3	-	-
333,4	8	11,0	24,0	87,6	25,0	11,0	35,0	2,0	0,23	0,18	10,3	17,6	14,1	0,1
438,2	8	14,0	31,0	87,6	10,0	17,0	14,0	2,0	0,50	0,17	15,7	14,5	8,0	5,6
438,2	8	14,0	24,0	87,6	10,0	11,0	35,0	2,0	0,50	0,19	15,7	18,1	-	-
438,2	8	14,0	26,0	99,0	22,5	11,0	37,0	2,0	0,77	0,42	21,1	28,1	14,2	1,2
438,2	8	14,0	26,0	99,0	22,5	11,0	37,0	4,0	0,77	0,42	21,1	28,1	-	-
438,2	8	14,0	41,0	111,7	25,0	18,0	18,0	4,0	0,77	0,66	19,8	31,6	12,9	5,0
438,2	8	14,0	41,0	111,7	25,0	18,0	18,0	5,0	0,77	0,66	19,8	31,6	12,9	3,7
438,2	8	14,0	46,0	119,1	32,0	18,0	16,0	2,0	1,10	0,70	28,8	32,1	-	-
438,2	8	14,0	34,0	119,1	37,0	13,0	47,0	4,0	1,10	0,70	28,8	40,5	20,5	1,5
542,9	6	17,0	53,0	130,5	34,0	20,0	20,0	5,0	2,42	1,41	40,3	50,7	-	-
542,9	6	17,0	53,0	130,5	34,0	20,0	20,0	6,0	2,42	1,41	43,4	51,4	16,6	9,9

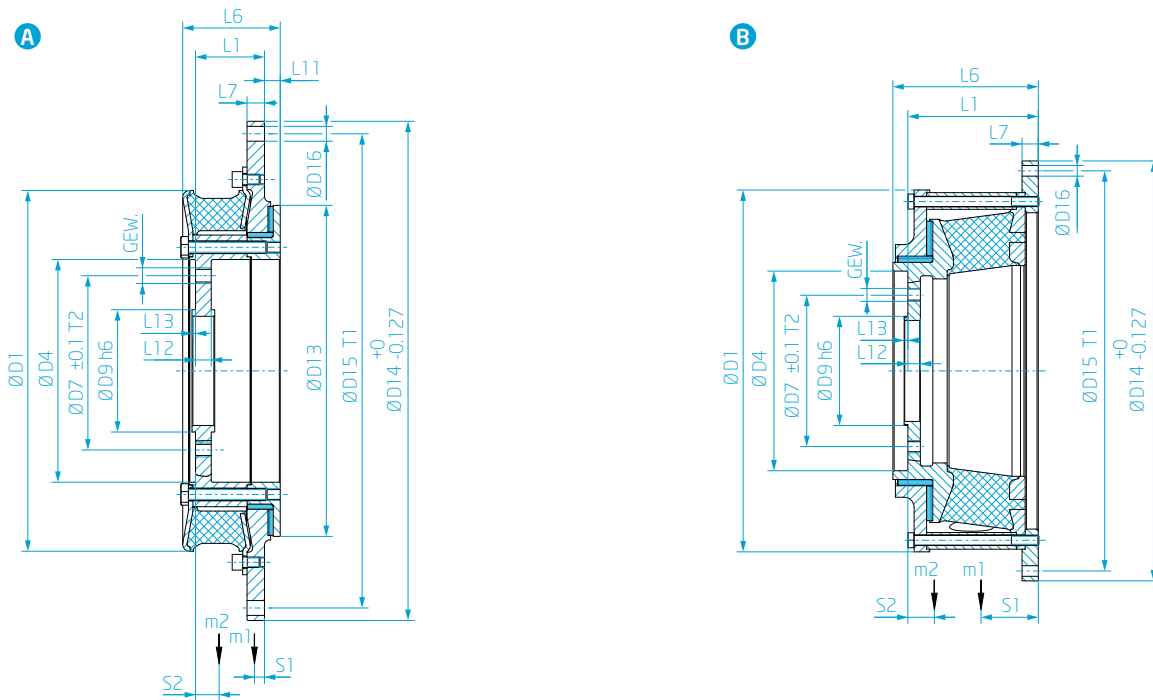

GEOMETRISCHE DATEN GEOMETRIC DATA

Baugruppe Dimension Group Schwungrad Flywheel Gelenkwellenanschluss Cardan shaft connection Abbildung Figure Abmessungen Dimension

	SAEJ620			Abbildung	Abmessungen	D ₁	D ₄	D ₇	T ₂	GEW.	D ₉	D ₁₃	D ₁₄	D ₁₅
	Dimension Group	Flywheel	Cardan shaft connection											
	[°]					[mm]	[mm]	[mm]	Teilung/holes	[mm]	[mm]	[mm]	[mm]	[mm]
K 1710	8	1	A	150,0	80,0	52,0	4	M6	35,0	147,0	263,5	244,5		
K 1710	8	2	A	150,0	80,0	62,0	6	M6	42,0	147,0	263,5	244,5		
K 1910	8	1	A	172,0	95,0	62,0	6	M6	42,0	166,0	263,5	244,5		
K 1910	8	2	A	172,0	95,0	74,5	4	M8	47,0	166,0	263,5	244,5		
K 2110	8	1	A	195,0	105,0	74,5	4	M8	47,0	192,0	263,5	244,5		
K 2110	8	2	A	195,0	105,0	84,0	6	M8	57,0	192,0	263,5	244,5		
K 2510	8	1	A	225,0	125,0	84,0	6	M8	57,0	208,0	263,5	244,5		
K 2510	8	2	A	225,0	125,0	101,5	8	M10	75,0	208,0	263,5	244,5		
K 2510	11½	1	A	225,0	125,0	84,0	6	M8	57,0	208,0	352,4	333,4		
K 2510	11½	2	A	225,0	125,0	101,5	8	M10	75,0	208,0	352,4	333,4		
K 2910	11½	1	A	269,0	155,0	101,5	8	M10	75,0	262,0	352,4	333,4		
K 2910	11½	2	A	269,0	155,0	130,0	8	M12	90,0	262,0	352,4	333,4		
K 3410	11½	1	A	313,0	185,0	130,0	8	M12	90,0	290,0	352,4	333,4		
K 3410	11½	2	A	313,0	185,0	155,5	8	M14	110,0	290,0	352,4	333,4		
K 3410	14	1	A	313,0	185,0	130,0	8	M12	90,0	298,0	466,7	438,2		
K 3410	14	2	A	313,0	185,0	155,5	8	M14	110,0	298,0	466,7	438,2		
K 4110	14	1	A	372,0	230,0	155,5	8	M14	110,0	354,0	466,7	438,2		
K 4110	14	2	A	372,0	230,0	196,0	8	M16	140,0	354,0	466,7	438,2		
K 4510	14	1	A	413,0	255,0	196,0	8	M16	140,0	387,0	466,7	438,2		
K 4510	14	2	A	413,0	255,0	218,0	8	M18	140,0	387,0	466,7	438,2		
K 4810	14	1	A	417,0	228,0	155,5	8	M14	110,0	391,0	466,7	438,2		
K 4810	14	2	A	417,0	228,0	196,0	8	M16	140,0	391,0	466,7	438,2		
K 5010	18	1	A	476,0	290,0	218,0	8	M18	140,0	444,0	571,5	542,9		
K 5010	18	2	A	476,0	290,0	245,0	8	M20	175,0	444,0	571,5	542,9		
K 5810	18	1	B	580,0	320,0	245,0	8	M20	175,0	-	571,5	542,9		
K 5810	18	2	B	580,0	320,0	280,0	8	M22	175,0	-	571,5	542,9		
K 5810	21	1	B	580,0	320,0	245,0	8	M20	175,0	-	673,1	641,4		
K 5810	21	2	B	580,0	320,0	280,0	8	M22	175,0	-	673,1	641,4		



Abmessungen
Dimension

Massenträgheitsmomente
Mass moments of inertia

Masse
Mass

Schwerpunktsabstand
Distance to center of gravity

	T_1	D_{16}	L_1	L_6	L_7	L_{11}	L_{12}	L_{13}	J_1	J_2	m_1	m_2	S_1	S_2
	[-] Teilung/holes	[mm]	[mm]	[mm]	[mm]	[mm]	[mm]	[mm]	[kgm ²]	[kgm ²]	[kg]	[kg]	[mm]	[mm]
	6	11,0	27,0	43,7	8,0	10,0	6,0	1,2	0,03	0,01	2,8	1,9	4,1	14,3
	6	11,0	27,0	43,7	8,0	10,0	6,0	1,5	0,03	0,01	3,2	1,9	4,1	14,3
	6	11,0	33,0	51,5	11,0	10,0	8,0	1,5	0,04	0,01	4,0	2,8	-	-
	6	11,0	33,0	51,5	11,0	10,0	8,0	2,0	0,04	0,01	4,0	2,8	-	-
	6	11,0	38,5	56,3	14,0	9,0	8,0	2,0	0,05	0,02	4,6	4,1	-	-
	6	11,0	38,5	56,3	14,0	9,0	8,0	2,0	0,05	0,02	4,6	4,1	-	-
	6	11,0	46,0	63,6	20,0	8,0	10,0	2,0	0,06	0,03	5,2	5,9	10,4	21,5
	6	11,0	46,0	63,6	20,0	8,0	10,0	2,0	0,06	0,03	5,2	5,9	10,4	21,5
	8	11,0	46,0	63,6	10,0	8,0	10,0	2,0	0,13	0,03	8,3	5,6	-	-
	8	11,0	46,0	63,6	10,0	8,0	10,0	2,0	0,13	0,03	8,3	5,6	-	-
	8	11,0	48,5	76,4	12,0	17,0	12,0	2,0	0,17	0,09	9,0	10,2	6,1	25,2
	8	11,0	48,5	76,4	12,0	17,0	12,0	2,0	0,17	0,09	9,0	10,2	6,1	25,2
	8	11,0	67,5	87,6	28,0	8,0	14,0	2,0	0,24	0,17	11,0	14,3	-	-
	8	11,0	67,5	87,6	28,0	8,0	14,0	2,0	0,24	0,16	11,0	14,3	-	-
	8	14,0	58,5	87,6	10,0	17,0	14,0	2,0	0,45	0,17	15,2	14,3	7,9	28,6
	8	14,0	58,5	87,6	10,0	17,0	14,0	2,0	0,45	0,16	15,2	14,3	7,9	28,6
	8	14,0	67,0	99,0	10,0	18,5	16,0	2,0	0,52	0,38	15,5	23,0	8,9	31,6
	8	14,0	67,0	99,0	10,0	18,5	16,0	4,0	0,52	0,38	15,5	23,0	8,9	31,6
	8	14,0	79,0	111,7	25,0	18,0	18,0	4,0	0,79	0,69	20,8	32,9	12,3	37,1
	8	14,0	79,0	111,7	25,0	18,0	18,0	5,0	0,79	0,69	20,8	32,9	12,3	37,1
	8	14,0	82,0	119,1	32,0	18,0	16,0	2,0	1,00	0,64	26,9	32,5	16,8	37,2
	8	14,0	82,0	119,1	32,0	18,0	16,0	4,0	1,00	0,64	26,9	32,5	18,8	37,2
	6	17,0	91,5	130,5	34,0	20,0	20,0	5,0	2,42	1,41	43,4	51,4	16,6	41,9
	6	17,0	91,5	130,5	34,0	20,0	20,0	6,0	2,42	1,41	43,4	51,4	16,6	41,9
	12	17,0	188,0	212,0	178,0	-	20,0	6,0	6,59	1,53	106,9	46,6	91,0	42,5
	12	17,0	188,0	212,0	178,0	-	20,0	6,0	6,59	1,53	106,9	46,6	91,0	42,5
	12	17,0	209,0	233,0	26,0	-	20,0	6,0	9,43	1,53	139,2	46,6	91,8	42,5
	12	17,0	209,0	233,0	26,0	-	20,0	6,0	9,43	1,53	139,2	46,6	91,8	42,5

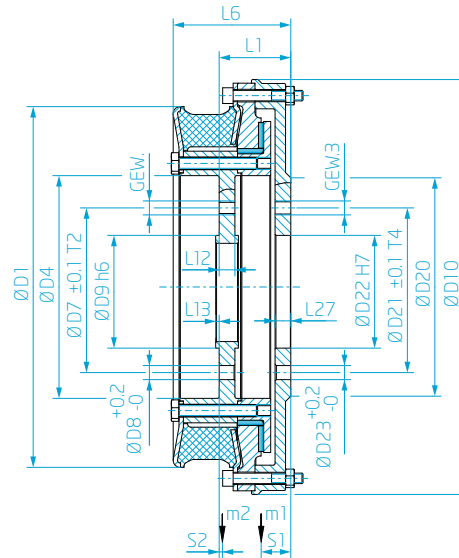

GEOMETRISCHE DATEN GEOMETRIC DATA

Baugruppe Dimension Group	Gelenkwellenanschluss Cardan shaft connection	Abmessungen Dimension										
		D ₁ [mm]	D ₄ [mm]	D ₇ [mm]	T ₂ [-] Teilung/holes	GEW. [mm]	D ₈ [mm]	D ₉ [mm]	D ₁₀ [mm]	D ₂₀ [mm]	D ₂₁ [mm]	T ₄ [-] Teilung/holes
K 1710	1	150,0	80,0	52,0	4	M6	6,1	35,0	182,0	75,0	52,0	4
K 1710	2	150,0	80,0	62,0	6	M6	6,1	42,0	182,0	75,0	62,0	6
K 1910	1	172,0	95,0	62,0	6	M6	6,1	42,0	204,0	90,0	62,0	6
K 1910	2	172,0	95,0	74,5	4	M8	8,1	47,0	204,0	90,0	74,4	4
K 2110	1	195,0	105,0	74,5	4	M8	8,1	47,0	234,0	100,0	74,5	4
K 2110	2	195,0	105,0	84,0	6	M8	8,1	57,0	234,0	100,0	84,0	6
K 2510	1	225,0	125,0	84,0	6	M8	8,1	57,0	270,0	120,0	84,0	6
K 2510	2	225,0	125,0	101,5	8	M10	10,1	75,0	270,0	120,0	101,5	8
K 2910	1	269,0	155,0	101,5	8	M10	10,1	75,0	314,0	150,0	101,5	8
K 2910	2	269,0	155,0	130,0	8	M12	12,1	90,0	314,0	150,0	130,0	8
K 3410	1	313,0	185,0	130,0	8	M12	12,1	90,0	360,0	180,0	130,0	8
K 3410	2	313,0	185,0	155,5	8	M14	14,1	110,0	360,0	180,0	155,5	8
K 4110	1	372,0	230,0	155,5	8	M14	14,1	110,0	420,0	225,0	155,5	8
K 4110	2	372,0	230,0	196,0	8	M16	16,1	140,0	420,0	225,0	196,0	8
K 4510	1	413,0	255,0	196,0	8	M16	16,1	140,0	475,0	250,0	196,0	8
K 4510	2	413,0	255,0	218,0	8	M18	18,1	140,0	475,0	250,0	218,0	8
K 4810	1	417,0	228,0	155,5	8	M14	14,1	110,0	475,0	225,0	155,5	8
K 4810	2	417,0	228,0	196,0	8	M16	16,1	140,0	475,0	225,0	196,0	8
K 5010	1	476,0	290,0	218,0	8	M18	18,1	140,0	580,0	285,0	218,0	8
K 5010	2	476,0	290,0	245,0	8	M20	20,1	175,0	580,0	285,0	245,0	8



Abmessungen Dimension		Massenträgheitsmomente Mass moments of inertia							Masse Mass		Schwerpunktsabstand Distance to center of gravity		
D ₂₂	GEW.3	D ₂₃	L ₁	L ₆	L ₁₂	L ₁₃	L ₂₇	J ₁	J ₂	m ₁	m ₂	S ₁	S ₂
[mm]	[mm]	[mm]	[mm]	[mm]	[mm]	[mm]	[mm]	[kgm ²]	[kgm ²]	[kg]	[kg]	[mm]	[mm]
35,0	M6	6,1	34,0	52,7	6,0	1,2	6,0	0,02	0,01	4,5	2,8	-	-
42,0	M6	6,1	34,0	52,7	6,0	1,5	6,0	0,02	0,01	4,5	2,8	-	-
42,0	M6	6,1	40,0	62,1	8,0	1,5	8,0	0,03	0,01	4,7	2,8	23,0	0,8
47,0	M8	8,1	40,0	62,1	8,0	2,0	8,0	0,03	0,01	4,7	2,8	23,0	0,8
47,0	M8	8,1	42,0	67,3	8,0	2,0	8,0	0,06	0,02	7,6	5,1	21,6	0,1
57,0	M8	8,1	42,0	67,2	8,0	2,0	8,0	0,06	0,02	7,6	5,1	21,6	0,1
57,0	M8	8,1	50,0	77,6	10,0	2,0	10,0	0,12	0,03	10,3	5,9	21,4	6,0
75,0	M10	10,1	50,0	77,6	10,0	2,0	10,0	0,12	0,03	10,3	5,9	21,4	6,0
75,0	M10	10,1	58,0	92,4	12,0	2,0	12,0	0,24	0,09	15,3	10,2	24,6	5,0
90,0	M12	12,1	58,0	92,4	12,0	2,0	12,0	0,24	0,09	15,3	10,2	24,6	5,0
90,0	M12	12,1	66,0	105,6	14,0	2,0	14,0	0,44	0,17	20,8	14,6	28,1	7,4
110,0	M14	14,1	66,0	105,6	14,0	2,0	14,0	0,44	0,17	20,8	14,6	28,1	7,4
110,0	M14	14,1	73,5	119,5	16,0	2,0	16,0	0,82	0,38	29,2	22,6	29,5	5,3
140,0	M16	16,1	73,5	119,5	16,0	4,0	16,0	0,82	0,38	29,2	22,6	29,5	5,3
140,0	M16	16,1	82,0	134,7	18,0	4,0	18,0	1,61	0,66	43,8	31,7	33,9	3,7
140,0	M18	18,1	82,0	134,7	18,0	5,0	18,0	1,61	0,66	43,8	31,7	33,9	3,7
110,0	M14	14,1	85,0	140,1	16,0	2,0	16,0	1,83	0,64	50,1	32,8	37,4	5,7
140,0	M16	16,1	85,0	140,1	16,0	4,0	16,0	1,83	0,64	50,1	32,8	37,4	5,7
140,0	M18	18,1	99,0	156,5	20,0	5,0	20,0	4,46	1,41	83,6	50,6	41,5	9,9
175,0	M20	20,1	99,0	156,5	20,0	6,0	20,0	4,46	1,41	83,6	50,6	41,5	9,9

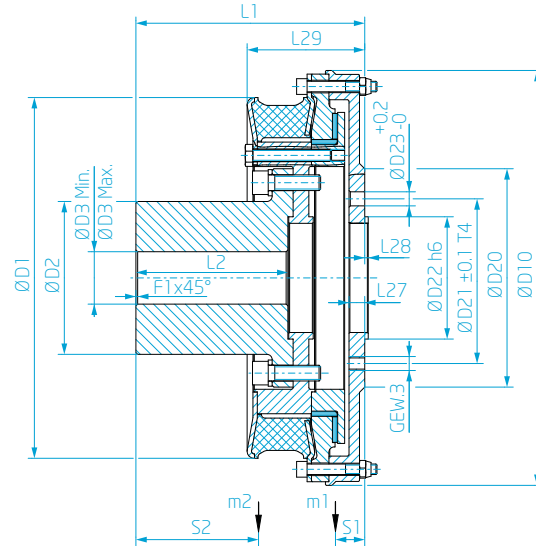

GEOMETRISCHE DATEN GEOMETRIC DATA

Baugruppe Dimension Group Gelenkwellenanschluss Cardan shaft connection Abmessungen Dimension

			D ₁	D ₂	D ₃		D ₁₀	D ₂₀	D ₂₁	T ₄	D ₂₂	GEW.3
			[mm]	[mm]	[mm] Min.	[mm] Max.	[mm]	[mm]	[mm]	[-] Teilung/holes	[mm]	[mm]
K 1710	1	150,0	42,0	12,0	30,0	182,0	75,0	52,0	4	35,0	M6	
K 1710	2	150,0	42,0	12,0	30,0	182,0	75,0	62,0	6	42,0	M6	
K 1910	1	172,0	52,0	15,0	36,0	204,0	90,0	62,0	6	42,0	M6	
K 1910	2	172,0	52,0	15,0	36,0	204,0	90,0	74,5	4	47,0	M8	
K 2110	1	195,0	62,0	20,0	44,0	234,0	100,0	74,5	4	47,0	M8	
K 2110	2	195,0	62,0	20,0	44,0	234,0	100,0	84,0	6	57,0	M8	
K 2510	1	225,0	78,0	25,0	55,0	270,0	120,0	84,0	6	57,0	M8	
K 2510	2	225,0	78,0	25,0	55,0	270,0	120,0	101,5	8	75,0	M10	
K 2910	1	269,0	105,0	30,0	78,0	314,0	150,0	101,5	8	75,0	M10	
K 2910	2	269,0	105,0	30,0	78,0	314,0	150,0	130,0	8	90,0	M12	
K 3410	1	313,0	126,0	40,0	90,0	360,0	180,0	130,0	8	90,0	M12	
K 3410	2	313,0	126,0	40,0	90,0	360,0	180,0	155,5	8	110,0	M14	
K 4110	1	372,0	160,0	50,0	115,0	420,0	225,0	155,5	8	110,0	M14	
K 4110	2	372,0	160,0	50,0	115,0	420,0	225,0	196,0	8	140,0	M16	
K 4510	1	413,0	175,0	60,0	125,0	475,0	250,0	196,0	8	140,0	M16	
K 4510	2	413,0	175,0	60,0	125,0	475,0	250,0	218,0	8	140,0	M18	
K 4810	1	417,0	160,0	50,0	115,0	475,0	225,0	155,5	8	110,0	M14	
K 4810	2	417,0	160,0	50,0	115,0	475,0	225,0	196,0	8	140,0	M16	
K 5010	1	476,0	196,0	70,0	140,0	580,0	285,0	218,0	8	140,0	M18	
K 5010	2	476,0	196,0	70,0	140,0	580,0	285,0	245,0	8	175,0	M20	

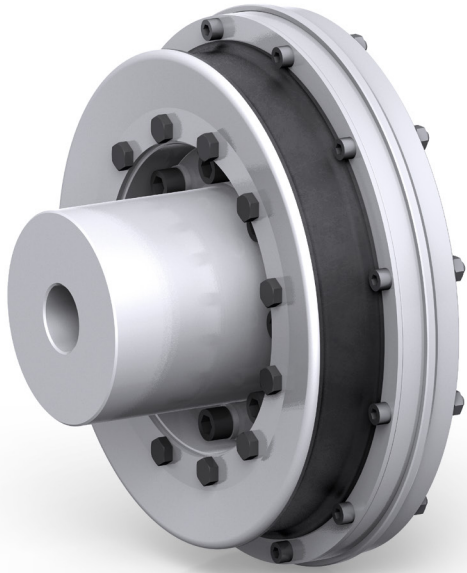

Abmessungen Dimension								Massenträgheitsmomente Mass moments of inertia		Masse Mass		Schwerpunktsabstand Distance to center of gravity	
D_{23}	L_1	L_2	L_{27}	L_{28}	L_{29}	F_1	J_1	J_2	m_1	m_2	S_1	S_2	
[mm]	[mm]	[mm]	[mm]	[mm]	[mm]	[mm]	[kgm ²]	[kgm ²]	[kg]	[kg]	[mm]	[mm]	
6,1	81,0	45,0	6,0	1,2	52,7	1,0	0,02	0,01	4,5	3,4	-	-	
6,1	81,0	45,0	6,0	1,5	52,7	1,0	0,02	0,01	4,5	3,4	-	-	
6,1	100,0	57,0	8,0	1,5	62,1	1,0	0,03	0,01	4,7	4,9	-	-	
8,1	100,0	57,0	8,0	2,0	62,1	1,0	0,03	0,01	4,7	4,9	-	-	
8,1	112,0	67,0	8,0	2,0	67,3	1,0	0,06	0,02	7,6	7,0	-	-	
8,1	112,0	67,0	8,0	2,0	67,3	1,0	0,06	0,02	7,6	7,0	-	-	
8,1	135,0	82,0	10,0	2,0	77,6	1,0	0,12	0,03	10,3	9,5	-	-	
10,1	135,0	82,0	10,0	2,0	77,6	1,0	0,12	0,03	10,3	9,5	-	-	
10,1	173,0	112,0	12,0	2,0	92,4	1,0	0,24	0,10	15,5	18,7	24,5	95,0	
12,1	173,0	112,0	12,0	2,0	92,4	1,0	0,24	0,10	15,5	18,7	24,4	95,0	
12,1	196,0	127,0	14,0	2,0	105,6	1,5	0,44	0,20	21,4	27,9	27,4	105,4	
14,1	196,0	127,0	14,0	2,0	105,6	1,5	0,44	0,20	21,4	27,9	27,5	105,4	
14,1	222,5	160,0	16,0	2,0	119,5	1,5	0,82	0,39	29,5	50,4	29,3	127,8	
16,1	238,5	160,0	16,0	4,0	119,5	1,5	0,75	0,50	27,2	49,1	29,4	127,8	
16,1	262,0	174,0	18,0	4,0	134,7	2,0	1,61	0,85	43,8	66,9	33,9	140,4	
18,1	262,0	174,0	18,0	5,0	134,7	2,0	1,61	0,85	43,8	66,9	33,9	140,4	
14,1	250,0	160,0	16,0	2,0	140,1	1,5	1,83	0,76	50,1	59,8	37,4	135,0	
16,1	250,0	160,0	16,0	4,0	140,1	1,5	1,83	0,76	50,1	59,8	37,4	135,0	
18,1	299,0	193,0	20,0	5,0	156,5	2,0	4,47	1,69	84,3	98,6	41,1	162,6	
20,1	299,0	193,0	20,0	6,0	156,5	2,0	4,47	1,69	84,3	98,6	41,1	162,6	

VULKARDAN P

EIGENSCHAFTEN CHARACTERISTICS

DREHMOMENT TORQUE

0.32 kNm – 31.50 kNm

EINSATZGEBIETE

Elastisch aufgestellte Anlagen.

Die VULKARDAN P ergänzt die VULKARDAN L für einen erweiterten Drehmomentbereich. Die Gummigewebekupplung mit progressiver Steifigkeitscharakteristik ist auch für anspruchsvolle Anwendungen geeignet und zeichnet sich durch eine hohe Resistenz gegenüber Stoßbelastungen aus. Analog zur VULKARDAN L besitzt die VULKARDAN P zwei gegeneinander abgestützte Innen- und Außenteile, sodass eine Gelenkwelle gestützt werden kann.

PRODUKTVORTEILE

- Maßgeschneidert für den Einsatz als Vorschaltkupplung bei Gelenkwellen
- Die kurze, kompakte Bauweise ergibt nur geringe Kurbelwellenbelastungen selbst bei großen Beugungswinkeln der Gelenkwellen
- Die Kupplungselemente weisen eine hohe Drehelastizität und eine gute Dämpfung auf für maximalen Schutz der Anlage
- Robuste Bauweise dank Gummigewebe für hohe Belastungen geeignet

AREAS OF APPLICATION

Flexibly mounted engines.

The VULKARDAN P is the supplement of the VULKARDAN L, covering a wider torque range. The fabric reinforced rubber element with a progressive stiffness characteristic is capable of handling all demanding applications – especially shock loads. Similar to the VULKARDAN L, the inner and outer coupling parts of the VULKARDAN P are connected by a friction bearing to support an attached Cardan shaft.

BENEFITS

- Customised for use as a clutch in Cardan shafts
- The shot and compact design results in only minor loads on the crankshaft even with large bending angles of the Cardan shafts
- The coupling elements have high torsional elasticity and good damping characteristics for maximum protection of the System
- Resilient design due to fabric reinforced rubber element

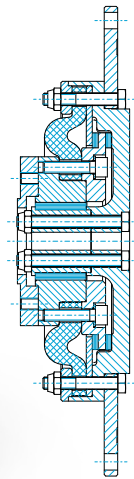

1630/1, 1630/2 BAUREIHE SERIES

**Zur Verbindung eines Schwungrades
oder Ähnlichem mit einer Gelenkwelle.**

Außenliegender Gelenkwellenanschluss in
zwei verschiedenen Durchmessern (1,2).
Gelenkwelle und Kupplung können getrennt
eingebaut werden.

Weitere Informationen auf Anfrage.

**For connecting a flywheel
or similar to a Cardan shaft.**

External Cardan shaft connection with two
different diameters (1,2). The Cardan shaft
and coupling can be installed individually.

Further Informations on request.

Baugruppe	Dimension Group	P 0502 – P 2002
Nenndrehmoment	Nominal Torque	0.32 kNm – 31.50 kNm

VULKARDAN L

BENÖTIGTE GELENKWELLENDATEN ZUR ÜBERPRÜFUNG DES ZULÄSSIGEN BEUGUNGSWINKELS

CARDAN SHAFT DATA REQUIRED FOR THE PERMISSIBLE DEFLECTION ANGLE

VULKARDAN L und VULKARDAN P Kupplungen sind im Allgemeinen bis zu einem Beugungswinkel der Gelenkwellen von 9° einsetzbar. Für eine genaue Überprüfung des zulässigen Beugungswinkels füllen Sie bitte das nachstehende Formular aus und senden Sie es Ihrem VULKAN Vertriebspartner.

VULKARDAN L and VULKARDAN P couplings can generally be used with a deflection angle of the Cardan shaft up to 9°. For an exact investigation of the permissible deflection angle, please fill in the following form and send it to your local VULKAN supplier.

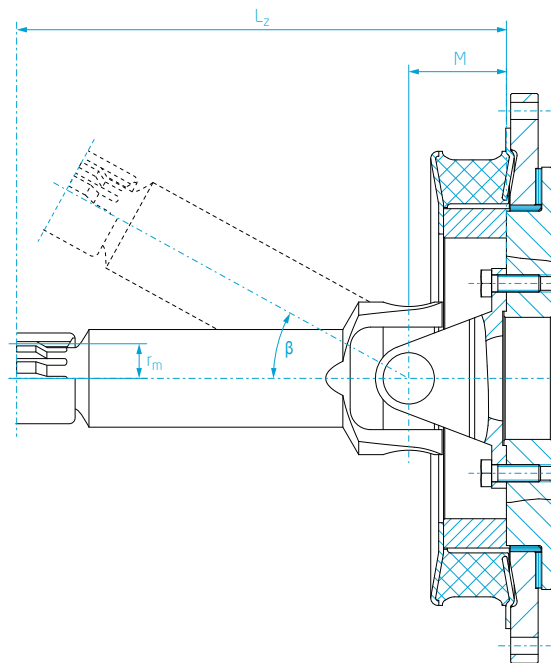

Gelenkwellenlänge

Cardan shaft length

L_z

M

Teilkreisradius der Verzahnung

Pitch circle radius of splines

r_m

Beugungswinkel

Deflection angle

β

Masse der Gelenkwelle

Mass of Cardan shaft

m

kg

Drehzahl

Speed

n_n

min⁻¹

Max. Wechsellmoment in der Anwendung

Max. vibratory torque of application

T_w

kNm

ERLÄUTERUNGEN DES PRODUKT-CODES EXPLANATIONS OF THE PRODUCT CODE

Alle VULKAN Couplings Produkte sind mit einem Produktcode gekennzeichnet. Dieser Code setzt sich aus verschiedenen Parameter-Angaben zusammen und ermöglicht es, unsere Produkte eindeutig zu identifizieren.

All VULKAN Couplings products are identified by a product code. This code consists of several parameters and it enables the clear identification of all products.

PRODUKT-CODE BEISPIEL VULKARDAN L

Hier haben wir den Code am Beispiel einer VULKARDAN L (K 2511), Größe 25, 1-reihig, Elementsteifigkeit 1, Baureihe 1660/2 entschlüsselt dargestellt.

LEISTUNGSDATEN PERFORMANCE DATA		
Kupplungstyp Type of Coupling		T_{KN} [kNm]
Größe Size	Baugruppe Dimension Group	Nenn Drehmoment Nominal Torque
K 2511	K 2510	0,63

Auszug aus den Leistungsdaten. Für vollständige Daten siehe ab Seite 08.
Excerpt from performance data. Complete data see page 08 ff.

PRODUCT CODE EXAMPLE VULKARDAN L

We have decoded here the product code of a VULKARDAN L (K 2511), Size 25, 1 row, Element stiffness 1, Series 1660/2.

Komplettkupplung Complete coupling	Produktfamilie Product family	Größenbezeichnung Size code	Elementreihen Element rows	Elementsteifigkeit Element stiffness	Baureihe Series	Schwungrad SAE Flywheel SAE	Kennzeichen Key
1	K	25	1	1	5	C	A

1	-----	K	-----	17	-----	1	1 Reihe 1 Row	-----	4	-----	0	1640/1	-----	A	8"	-----	A	VULKARDAN L
				19					1		1	1640/2		B	10"			
				21					5		4	1660/1		C	11,5"			
		25		29					2		5	1660/2		D	14"			
				34							6	1670		F	18"			
				41							7	1680/1						
				45							8	1680/2						
				48							9	1690/1						
				50							A	1690/2						
				58														

ONLINE-SERVICE

WEITERE INFORMATIONEN FINDEN SIE AUF WWW.VULKAN.COM FOR FURTHER INFORMATION, PLEASE REFER TO OUR WEBSITE WWW.VULKAN.COM

VULKARDAN L&P

www.vulkan.com/de-de/couplings/produkte/gelenkwellenkupplungen



VULKARDAN L&P

www.vulkan.com/en-us/couplings/products/Cardan-shaft-couplings

KATALOGE & BROSCHÜREN

www.vulkan.com/de-de/couplings/downloads-videos



CATALOGUES & BROCHURES

www.vulkan.com/en-us/couplings/downloads-videos

VULKAN ENGINEERING PORTAL

www.vulkan.com/de-de/couplings/service/vulkan-engineering-portal



VULKAN ENGINEERING PORTAL

www.vulkan.com/en-us/couplings/service/vulkan-engineering-portal

PRODUKTSELEKTOR

www.vulkan.com/de-de/couplings/service/produktselektor



PRODUCT SELECTOR

www.vulkan.com/en-us/couplings/service/product-selector

AUTORISIERTE HÄNDLER

www.vulkan.com/de-de/couplings/kontakt



AUTHORISED DISTRIBUTORS

www.vulkan.com/en-us/couplings/contact

VIDEOS

www.vulkan.com/de-de/couplings/downloads-videos/videos



VIDEOS

www.vulkan.com/en-us/couplings/downloads-videos/videos

GÜLTIGKEITSKLAUSEL

Die enthaltenen technischen Daten sind nur gültig bei Einsatz in definierten Anwendungsgebieten. Diese umfassen:

- ⌚ Haupt- und Nebenantriebe auf Schiffen
- ⌚ Generatorsätze auf Schiffen
- ⌚ Antriebe für stationäre Energieerzeugung mit Diesel- oder Gasmotoren

Abweichende Anwendungen bedürfen einer individuellen Betrachtung. Bitte kontaktieren Sie hierzu ihren lokalen VULKAN Vertreter.

Die vorliegende Broschüre ersetzt alle vorherigen Ausgaben, ältere Drucke verlieren ihre Gültigkeit. VULKAN ist berechtigt, aufgrund neuerer Entwicklungen die in dieser Broschüre enthaltenen Daten entsprechend anzupassen und zu verändern. Die neuen Daten gelten nur für nach der Änderung bestellte Kupplungen. Es liegt im Verantwortungsbereich des Anwenders dafür zu sorgen, dass ausschließlich die aktuelle Katalogversion verwendet wird. Der jeweils aktuelle Stand ist auf der Webseite von VULKAN unter www.vulkan.com jederzeit abrufbar.

Die Angaben in dieser Broschüre beziehen sich auf den technischen Standard gültig im Hause VULKAN und stehen unter den in den Erläuterungen definierten Bedingungen. Es liegt allein im Entscheidungs- und Verantwortungsrahmen des Systemverantwortlichen für die Antriebslinie, entsprechende Rückschlüsse auf das Systemverhalten zu ziehen.

VULKAN Drehschwingungsanalysen berücksichtigen in der Regel nur das rein mechanische Schwingungssystem. Als reiner Komponentenhersteller übernimmt VULKAN mit der Analyse des Drehschwingungssystems (stationär, transient) nicht die Systemverantwortung! Die Genauigkeit der Analyse hängt von der Genauigkeit der verwendeten bzw. der VULKAN zur Verfügung gestellten Daten ab.

Änderungen aufgrund des technischen Fortschritts sind vorbehalten. Bei Unklarheiten bzw. Rückfragen kontaktieren Sie bitte VULKAN.

Stand: 07/2019

Das Recht auf Vervielfältigung, Nachdruck und Übersetzungen behalten wir uns vor. Maß- und Konstruktionsänderungen vorbehalten.

VALIDITY CLAUSE

The containing technical data is valid only for defined areas of applications. These includes:

- ⌚ Main propulsion and auxiliary drives on ships
- ⌚ Generator sets on ships
- ⌚ Drives for stationary energy production with diesel or gas engines

For other than the named applications please contact your local VULKAN supplier for further consideration.

The present catalogue shall replace all previous editions, any previous printings shall no longer be valid. Based on new developments, VULKAN reserves the right to amend and change any details contained in this catalogue respectively. The new data shall only apply with respect to couplings that were ordered after said amendment or change. It shall be the responsibility of the user to ensure that only the latest catalogue issue will be used. The respective latest issue can be seen on the website of VULKAN on www.vulkan.com.

The data contained in this catalogue refer to the technical standard as presently used by VULKAN with defined conditions according to the explanations. It shall be the sole responsibility and decision of the system administrator for the drive line to draw conclusions about the system behaviour.

VULKAN torsional vibration analysis usually only consider the pure mechanical mass-elastic system. Being a component manufacturer exclusively, VULKAN assumes no system responsibility with the analysis of the torsional vibration system (stationary, transiently)! The accuracy of the analysis depends on the exactness of the used data and the data VULKAN is provided with, respectively.

Any changes due to the technological progress are reserved. For questions or queries please contact VULKAN.

Status: 07/2019

All duplication, reprinting and translation rights are reserved. We reserve the right to modify dimensions and constructions without prior notice.

PUBLISHER:

VULKAN Couplings

CONCEPT AND DESIGN:

Hackforth Holding GmbH & Co. KG
VULKAN Marketing
Heerstraße 66, 44653 Herne / Germany
E-mail: marketing@vulkan.com

STATUS: 07/2019

All duplication, reprinting and translation rights are reserved. Any changes due to the technological progress are reserved. For questions or queries please contact VULKAN.