



2IN1 SOLUTIONS
THE COMPACT COUPLING/
CLUTCH COMBINATION



Stromag

Founded in 1932, Stromag has grown to become a globally recognized leader in the development and manufacture of innovative power transmission components for industrial drivetrain applications. Stromag engineers utilize the latest design technologies and materials to provide creative, energy-efficient solutions that meet their customer's most challenging requirements.

Stromag's extensive product range includes flexible couplings, disc brakes, limit switches, an array of hydraulically, pneumatically, and electrically actuated brakes, and a complete line of electric, hydraulic and pneumatic clutches.

Stromag engineered solutions improve drivetrain performance in a variety of key markets including energy, off-highway, metals, marine, transportation, printing, textiles, and material handling on applications such as wind turbines, conveyor systems, rolling mills, agriculture and construction machinery, municipal vehicles, forklifts, cranes, presses, deck winches, diesel engines, gensets and stage machinery.



VISIT US ON THE WEB AT **STROMAG.COM**

VISIT US ON THE WEB AT **REGALREXNORD.COM**



AT A GLANCE

	Product range	4
	Benefits include / Classifications / The torsional vibration analysis	6
	Construction kit	8
1) ENCLOSED 2in1 SOLUTION		
	Example 01 Enclosed 2in1 Solution for pump drives	10
	Example 02 Enclosed 2in1 Solution for cardan shaft connection	12
	Example 03 Enclosed 2in1 Solution for pulley connection	14
2) NON-ENCLOSED 2in1 SOLUTION FOR RIGID MOUNTED ENGINES (PERIFLEX®VN)		
	Example Non-enclosed 2in1 Solution for pump drives	16
3) NON-ENCLOSED 2in1 SOLUTION FOR FLEXIBLE MOUNTED ENGINES (TEF)		
	Example 01 Non-enclosed 2in1 Solution for PTO/PTI drives	18
	Example 02 Non-enclosed 2in1 Solution for hybrid drives	20
4) NON-ENCLOSED 2in1 SOLUTION FOR AUXILIARY DRIVES		
	Example Simple 2in1 Solution for PTO/PTI drives	22

2in1 – COUPLING/CLUTCH SOLUTIONS

ELECTRIC

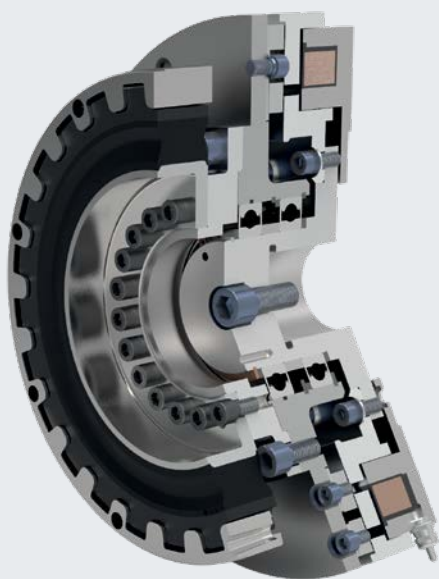

2in1 – Periflex®VN/MWU Combination



2in1 – SSC/MWU Combination

Regal Rexnord is the only company worldwide that manufactures elastic couplings as well as a wide range of switchable clutches.

Stromag's "2in1 solutions" enable the unique possibility to take this big advantage for nearly every drivetrain application. We simply combine the elastic coupling and the switchable clutch in a compact and smart design. The calculation and selection of both parts from Stromag's well proven product portfolio is done by our support according to the needed specification.

HYDRAULIC

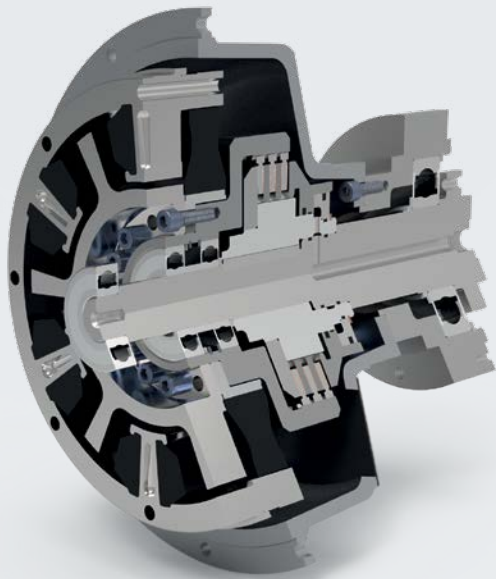

2in1 – Periflex®VN/KHA Combination

PNEUMATIC

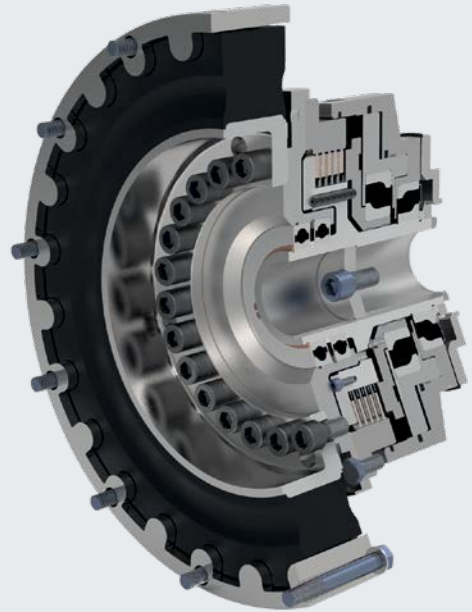

2in1 – Periflex®VN/KPR Combination

- No time-consuming interface clarification meetings between elastic coupling and clutch supplier
- Space and cost saving design
- Plug and play solutions lead to reduced assembly times on site
- Suitable 2in1 solutions for nearly every combination between M/E, E-motor, pumps, generators and belt drives are available

Stromag – Clutches and Brakes

AT A GLANCE

2in1– COUPLING/CLUTCH COMBINATION

BENEFITS INCLUDE

- Electromagnetic, hydraulic or pneumatic clutch actuations
- Optional bell housings
- Drivetrain torsional vibration analysis for OEM applications
- Additional bearing supports
- Tailormade or standardized (SAE, etc.) interfaces



CLASSIFICATIONS



For survey of the coupling by a classification society, the regulations of the society have to be adhered to. The coupling characteristics may differ from the definitions given in this catalogue. Accordingly prepared data sheets are available on request. A number of classification societies prescribe fail-safe devices on ships main drives.

THE TORSIONAL VIBRATION ANALYSIS

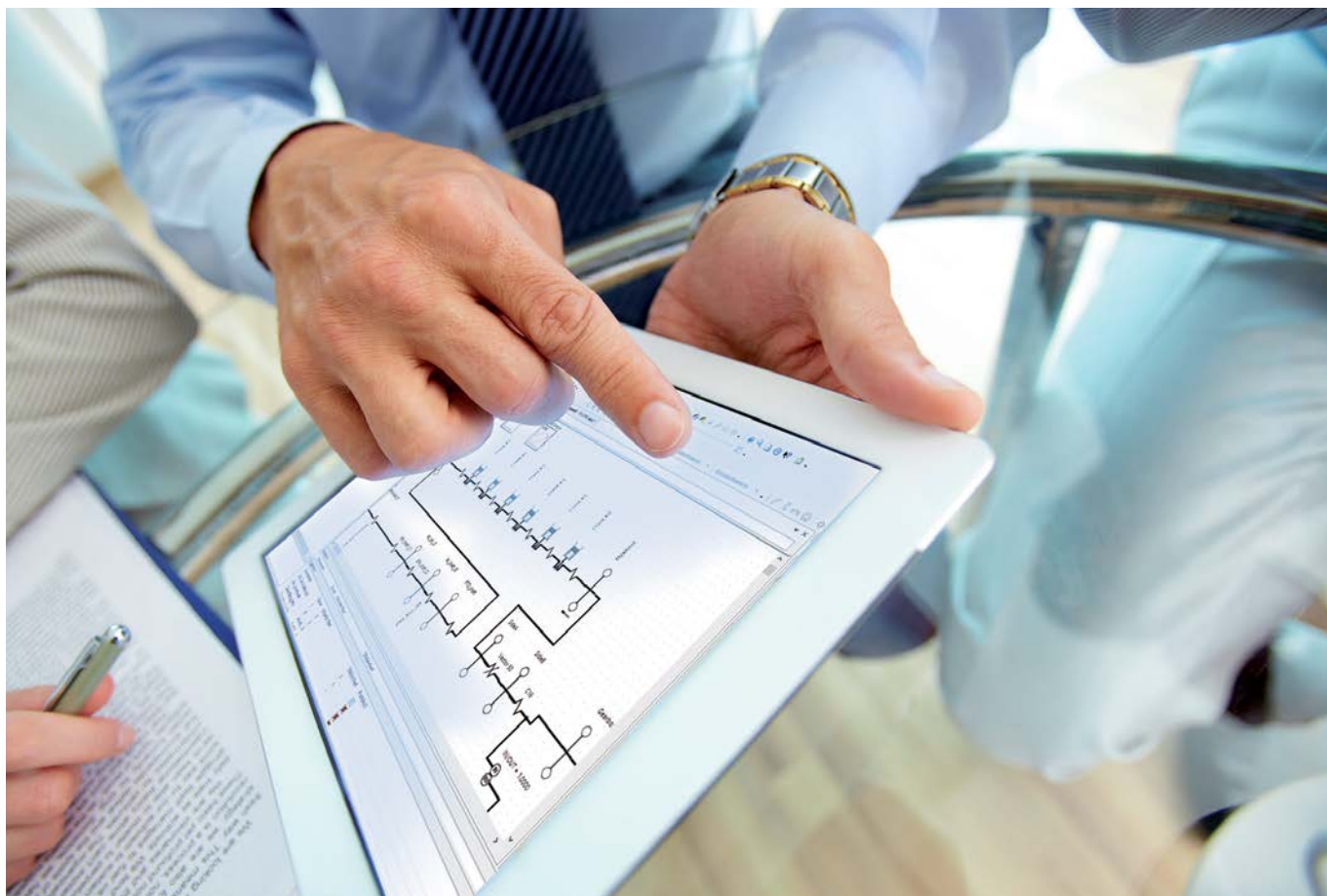

Stromag's know-how in Torsional Vibration Analysis (TVA) constitutes the core of each coupling design. It provides a comprehensive analysis of loads in the crankshaft, coupling and driven side to ensure that critical speeds can be moved per application requirements.

Unevenly rotating systems can severely degrade product quality and cause great harm to the powertrain. On a daily basis, the TVA experts at Stromag work on the challenge of detecting such deviations by measuring them and protecting the entire powertrain with ideal product selection. Stromag is capable of calculating stationary and transient operating conditions considering the stiffness and damping of the elastomers.

Stromag – Clutches and Brakes

2in1 – Clutch and Coupling Combination

Electric MWU

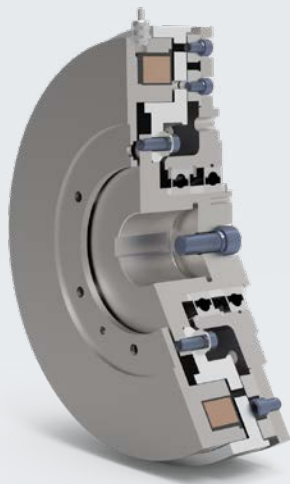

Size	20 – 1600
Torque [Nm]	400 – 20800
Outer diameter [mm]	192 – 690

Hydraulic KHA

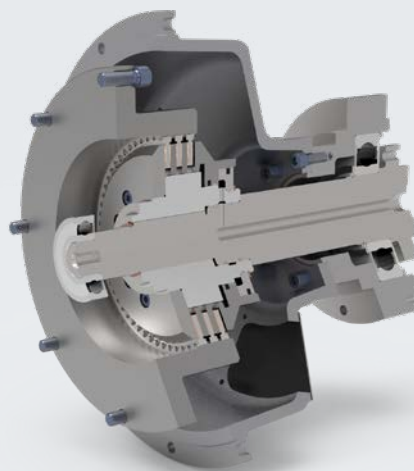

Size	70 – 500
Torque [Nm]	690 – 6100
Outer diameter [mm]	220 – 370

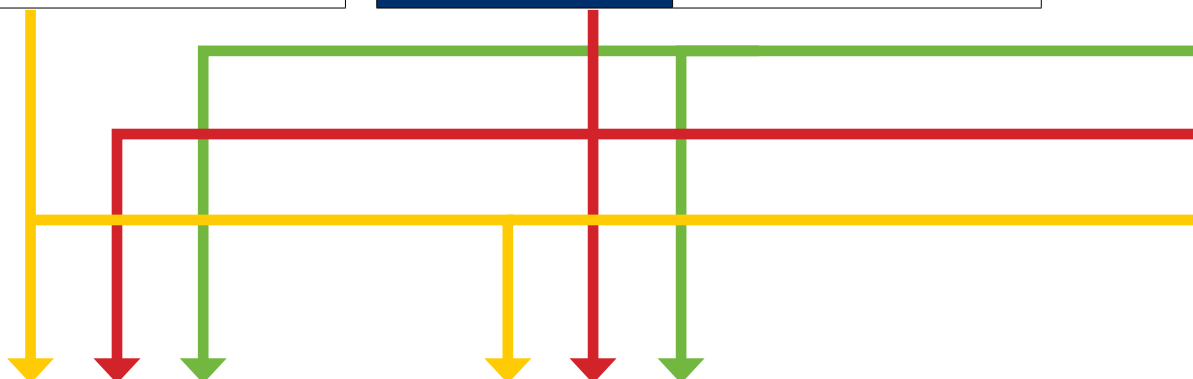

PERIFLEX® VN COUPLINGS



Size	183 – 726
Torque [Nm]	200 – 31500
Outer diameter [mm]	6,5" – 24"

SSC –
STEEL SPRING COUPLING



Size	11,5 – 14
Torque [Nm]	2550 – 4170
Outer diameter [mm]	11,5" – 14"

Stromag – Clutches and Brakes

2in1 – Clutch and Coupling Combination



Size	20 – 900
Torque [Nm]	20 – 9200
Outer diameter [mm]	116 – 435

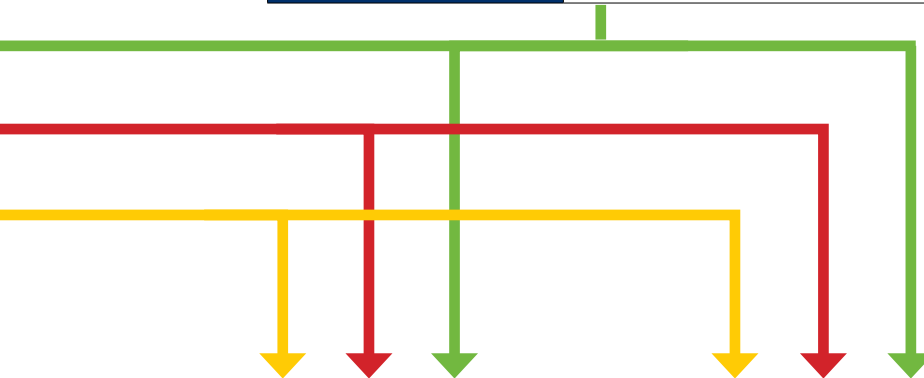

Size	31 – 124
Torque [Nm]	2000 – 63000
Outer diameter [mm]	11,5" – 24"



Size	201 R – 1832 R
Torque [Nm]	25 – 15000
Outer diameter [mm]	86 – 700

Additional options for your 2in1 Solution



Bell housing



Stand



Internet of Things

Other sizes upon request

Stromag – Clutches and Brakes

2in1 – Clutch and Coupling Combination

1 Enclosed 2in1 Solution for pump drives

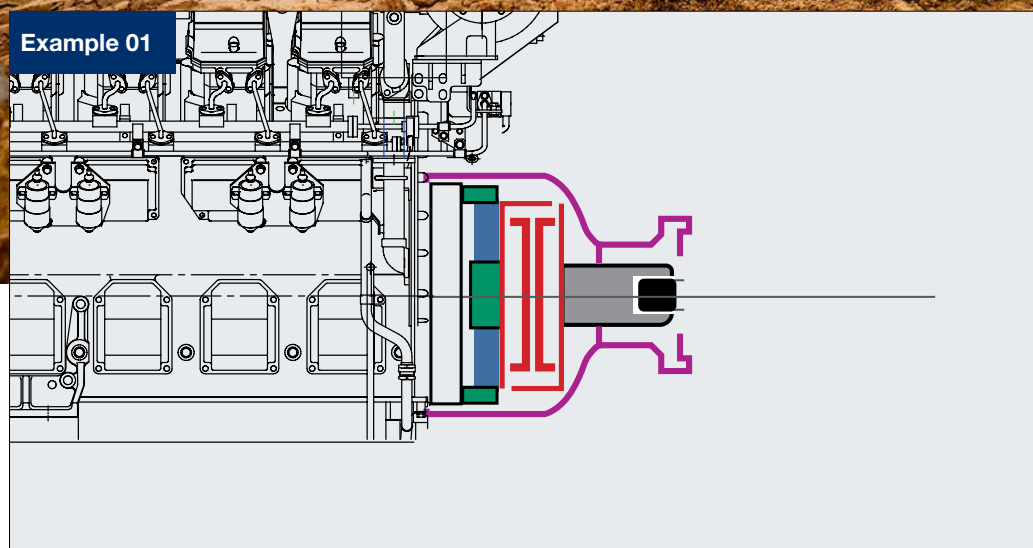

The standards includes:

- Enclosed unit for direct mounting on internal combustion engines according to the SAE standard
- Output-side preparation for connecting work machines
- “Plug and Play” Solution

Stromag – Clutches and Brakes

2in1 – Clutch and Coupling Combination

Example application: Compact 2in1 solution, consisting of our flexible coupling, Periflex® VN and electromagnetic pole-face friction clutch, MWU for connecting and disconnecting various pumps and compressors, for example in construction machinery.

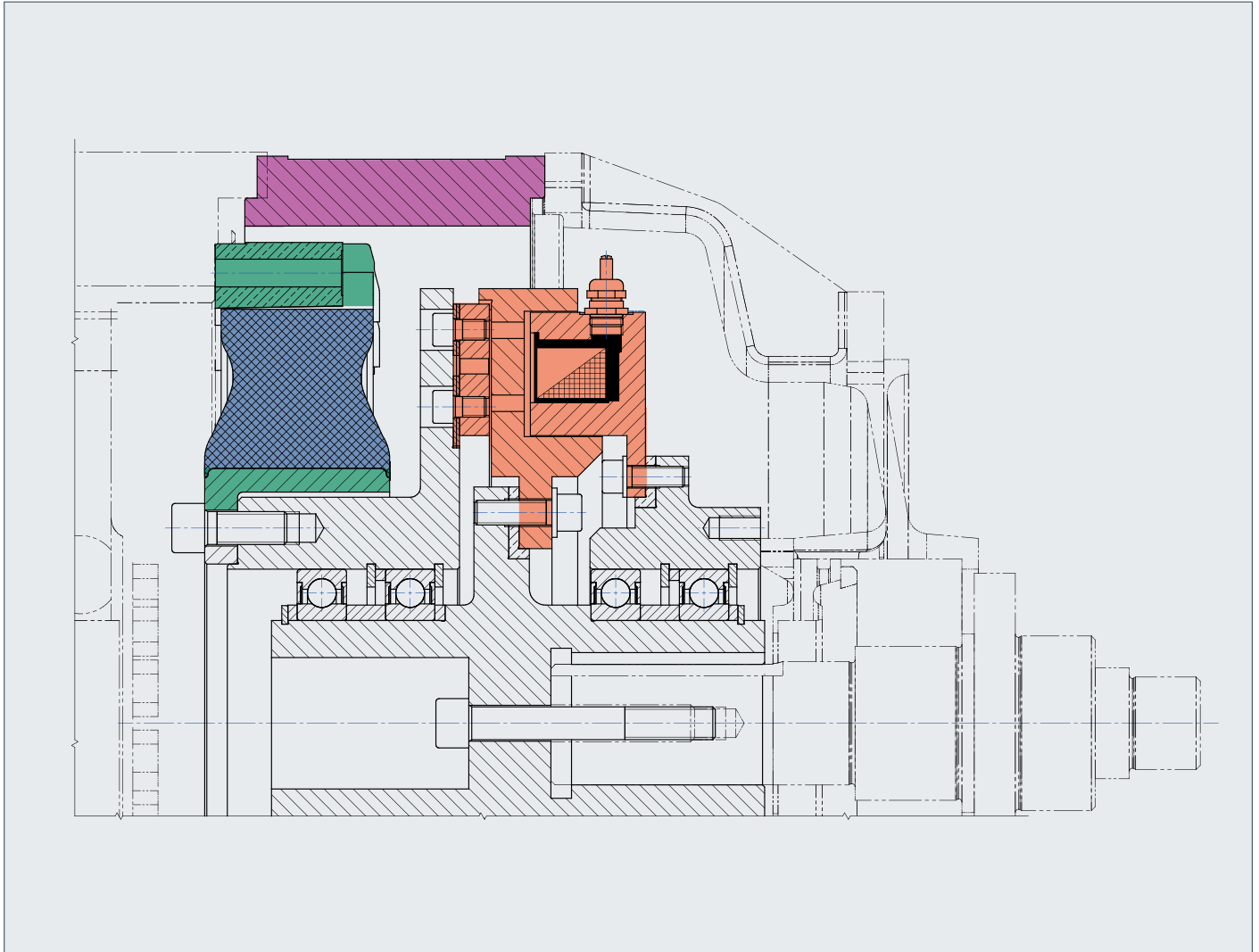

Technical data		
2in1 combination	MWU 160-400 Periflex®VN 43611	
Static torque	[Nm]	5600
max. admissible speed	[1/min]	1800
Torsional stiffness	[Nm/rad]	25400
Connection drive side	engine housing connection	SAE 1
	flywheel connection	SAE 14"
Connection driven side	Shaft-Ø 60mm / Key	
Outer diameter	[mm]	552
Length	[mm]	288,5
Weight	[kg]	171
Actuation method	engaged by electrical current	

Customer specific features:

- Integration into existing drive system
- Bell housing adapted to expand the existing installation space
- Customer adjustment unnecessary due to internal bearings
- Deactivation of the output with almost no residual torque

Stromag – Clutches and Brakes

2in1 – Clutch and Coupling Combination

1 Enclosed 2in1 Solution for cardan shaft connection

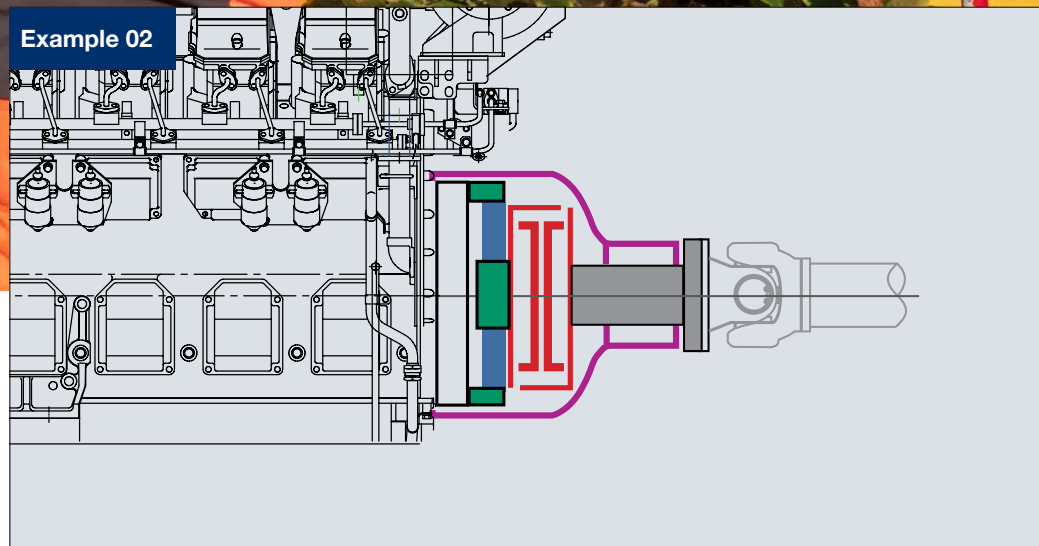

The standards includes:

- Enclosed unit for direct mounting on internal combustion engines according to the SAE standard
- Output-side preparation for connecting cardan shafts
- “Plug and Play” Solution

Stromag – Clutches and Brakes

2in1 – Clutch and Coupling Combination

Example application: Compact 2in1 solution, consisting of our flexible coupling, Periflex® VN and electromagnetic pole-face friction clutch, MWU for connecting and disconnecting various work equipment, for example on municipal vehicles.

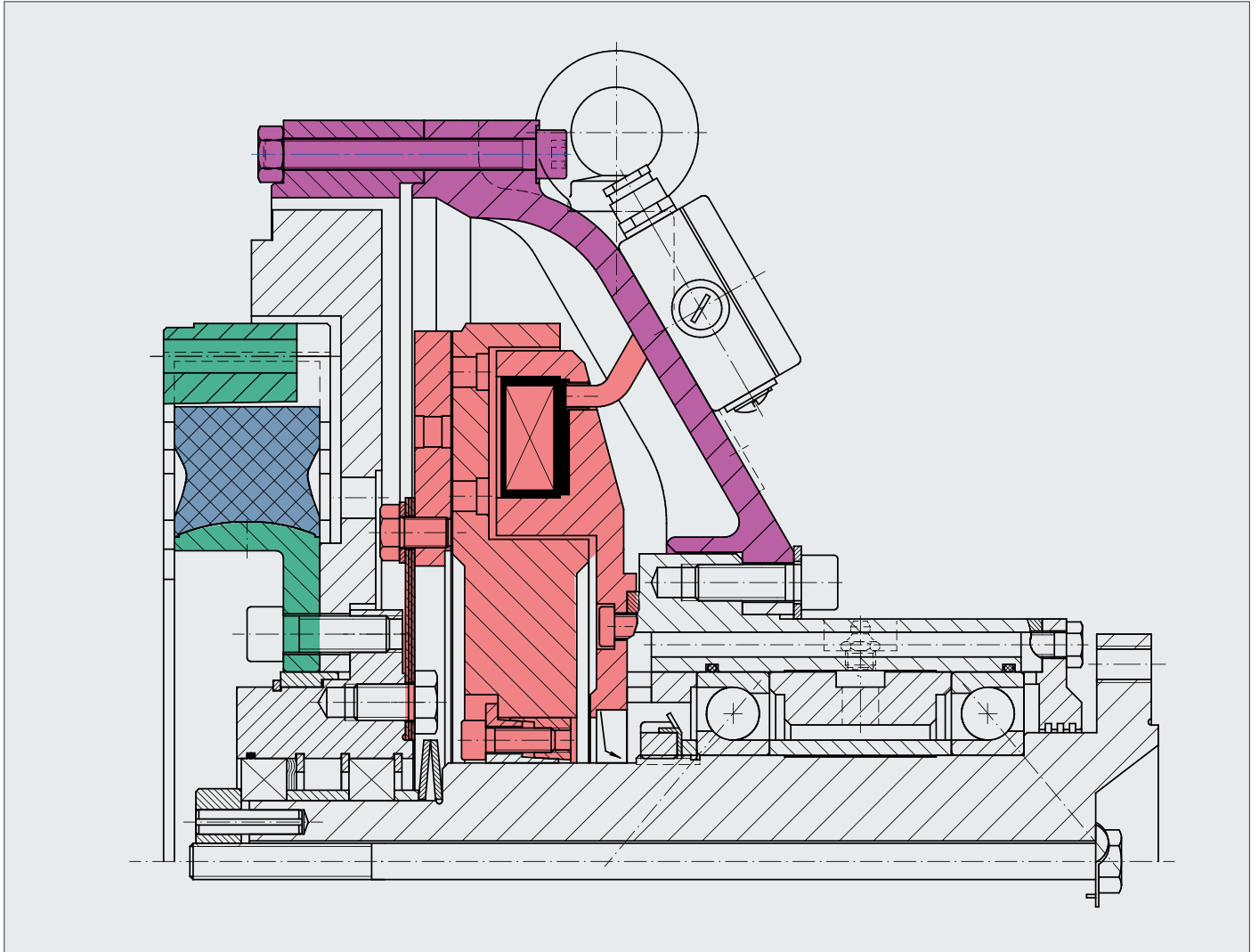

Technical data		
2in1 combination	MWU 60-150 Periflex®VN 358	
Static torque	[Nm]	2100
max. admissible speed	[1/min]	1800
Torsional stiffness	[Nm/rad]	16700
Connection drive side	engine housing connection	SAE 2
	flywheel connection	SAE 11,5"
Connection driven side	Flange / pitch circle diameter 130 mm	
Outer diameter	[mm]	489
Length	[mm]	326
Weight	[kg]	120
Actuation method	engaged by electrical current	

Customer specific features:

- Easy installation in drivetrain
- Central wear adjustment
- Integrated additional mass for vibration damping
- Robust cardan shaft bearing

Stromag – Clutches and Brakes

2in1 – Clutch and Coupling Combination

1 Enclosed 2in1 Solution for pulley connection

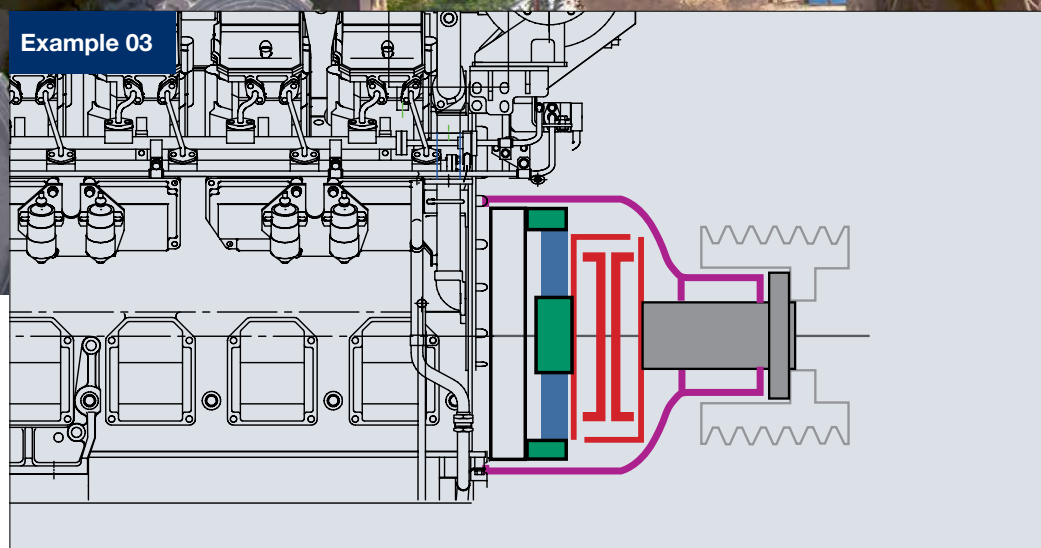

The standards includes:

- Enclosed unit for direct mounting on internal combustion engines according to the SAE standard
- Preparation on the output side for connecting belt drives
- “Plug and Play” solution

Stromag – Clutches and Brakes

2in1 – Clutch and Coupling Combination

Example application: Compact 2in1 solution, consisting of our flexible coupling, Periflex® VN and hydraulic multi-disc clutch, KHA for connecting and disconnecting various tools via belt drives, e.g. in asphalt milling machines.

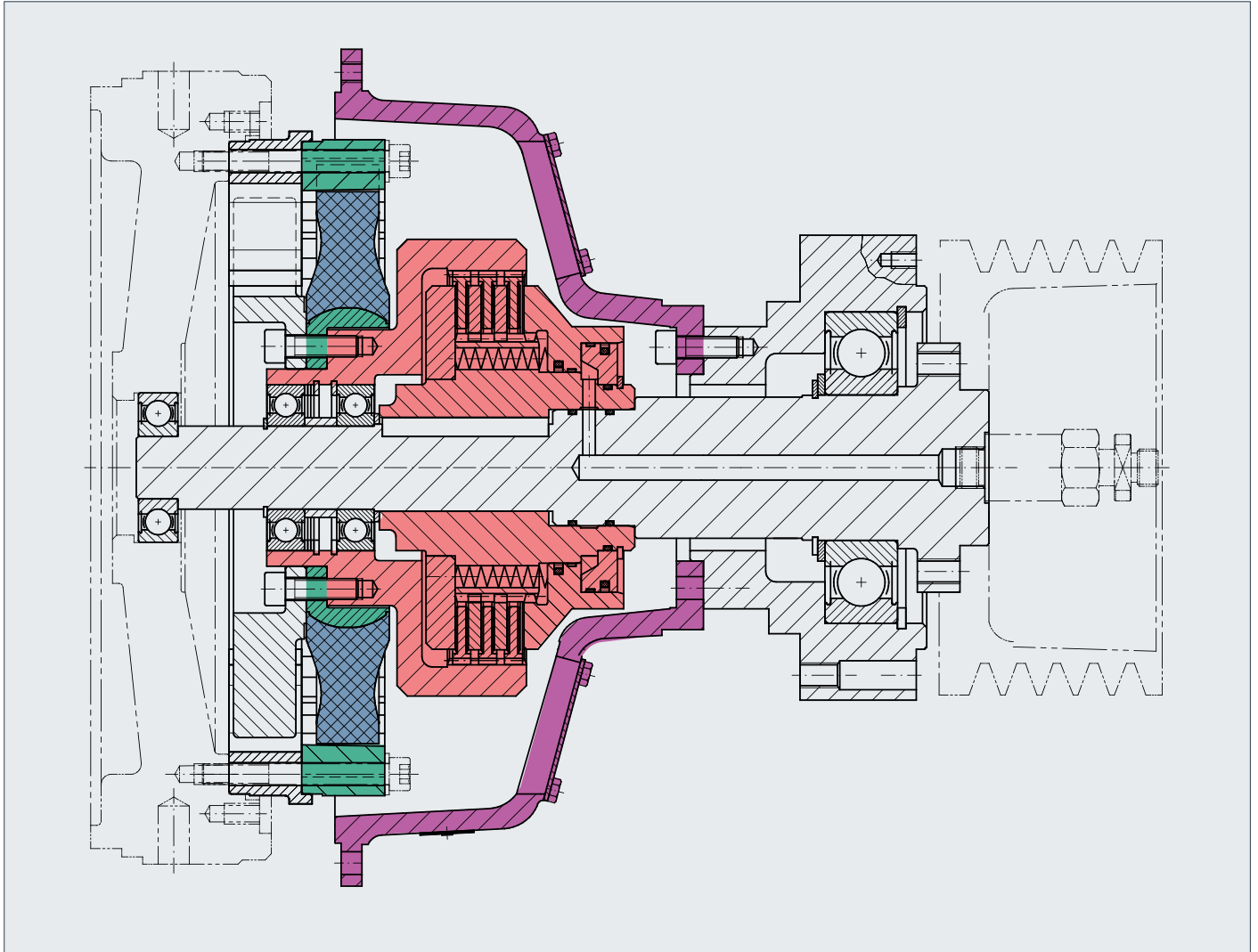

Technical data		
2in1 combination	KHA 130 Periflex®VN/Periflex®IC	
Static torque	[Nm]	1100
max. admissible speed	[1/min]	2250
Torsional stiffness	[Nm/rad]	3760
Connection drive side	engine housing connection	SAE 4
	flywheel connection	SAE 10"
Connection driven side	Flange / pitch circle diameter	100 mm
Outer diameter	[mm]	403,2
Length	[mm]	410,6
Weight	[kg]	78,3
Actuation method	hydraulic	

Customer specific features:

- High power density due to compact disk design
- Integrated pilot bearing
- Central and easily accessible pressurized oil supply
- Robust pulley bearing

Stromag – Clutches and Brakes

2in1 – Clutch and Coupling Combination

2 Non-enclosed 2in1 Solution for pump drives

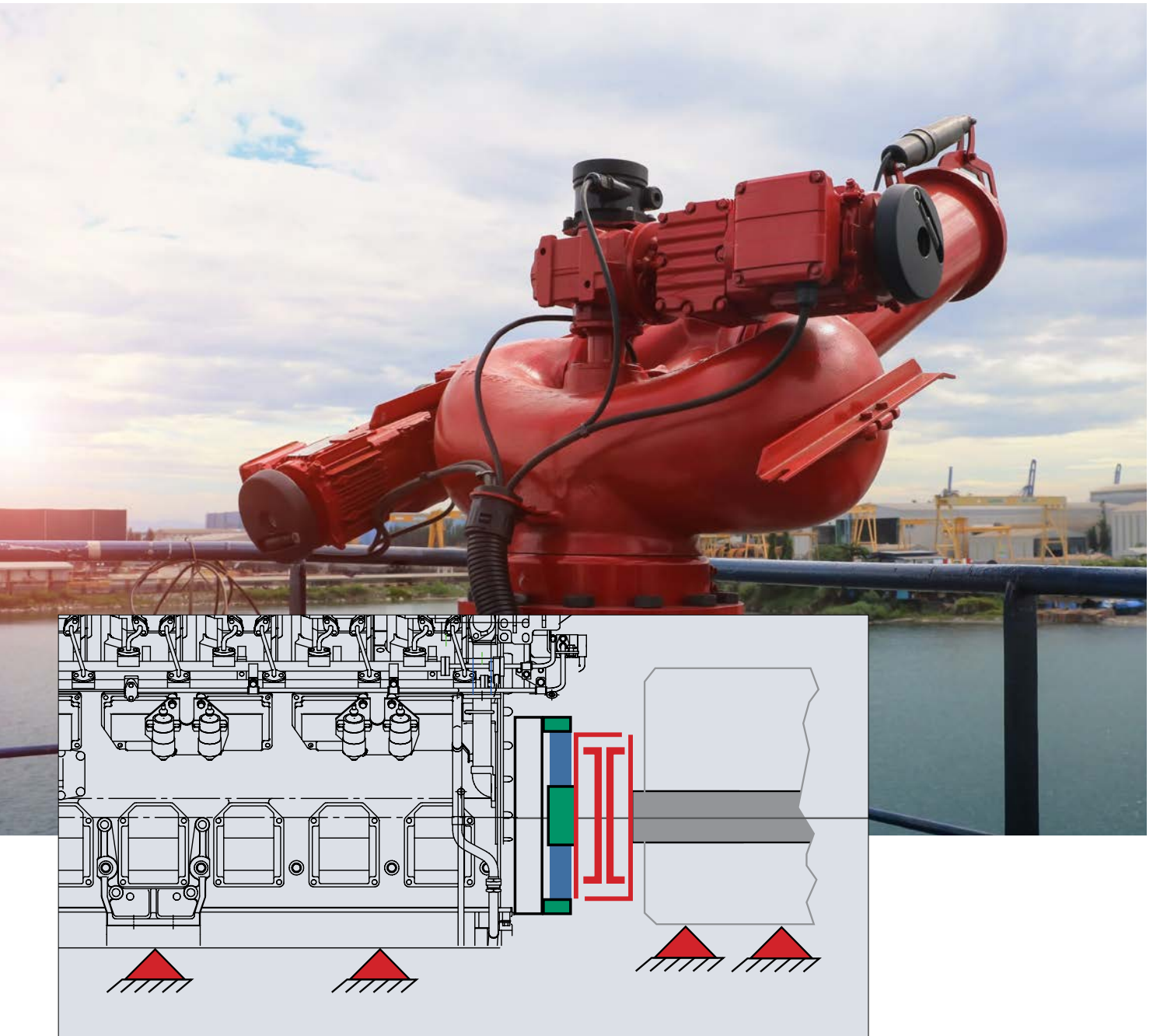

The standards includes:

- Engine and work machine fixed installation
- Compact design
- “Plug and Play” solution

Stromag – Clutches and Brakes

2in1 – Clutch and Coupling Combination

Example application: Compact 2in1 solution, consisting of our flexible coupling, Periflex® VN and pneumatic multi-disc clutch, KPR for connecting and disconnecting various pumps and compressors, e.g. fire pumps.

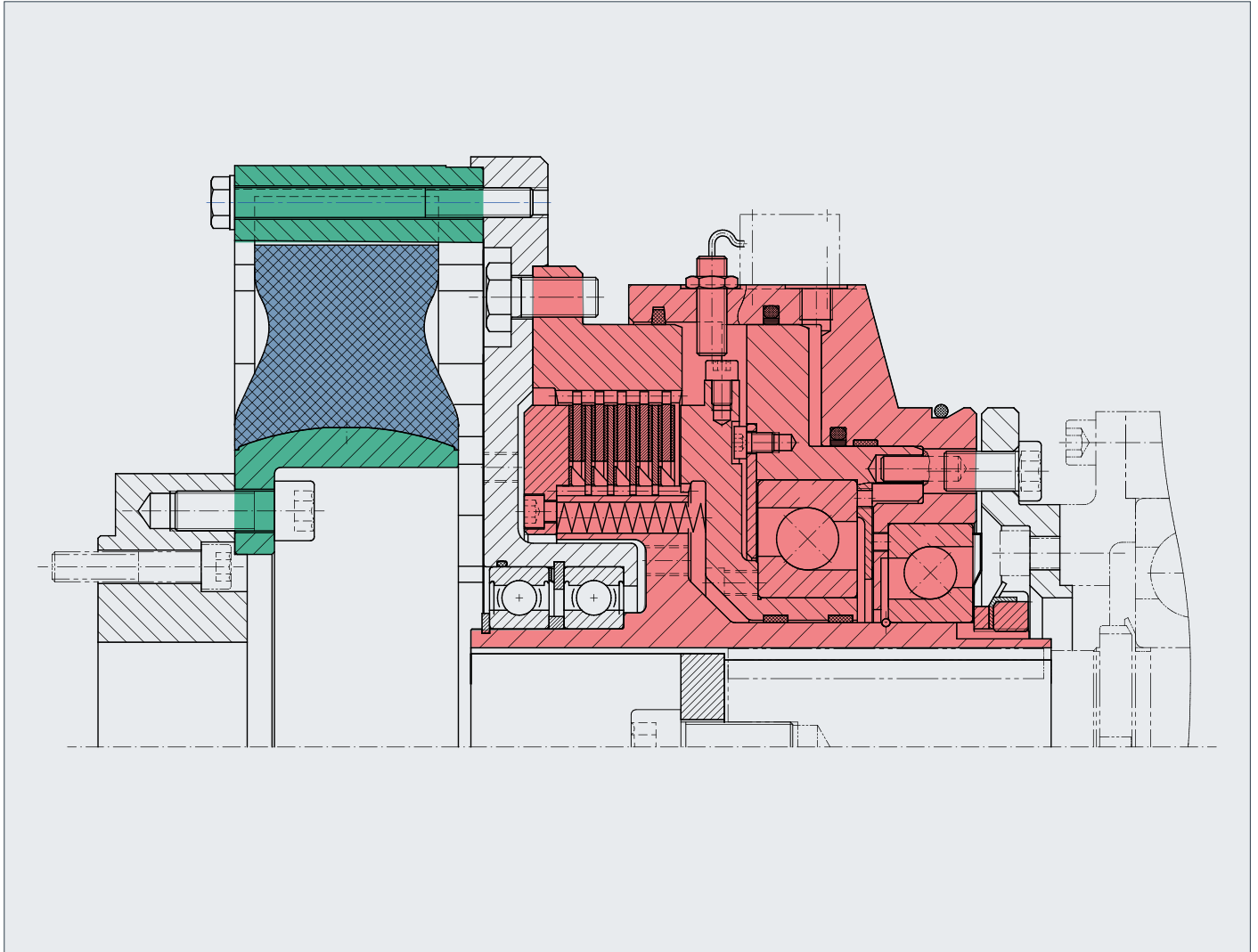

Technical data		
2in1 combination	KPR 800 Periflex®VN 43611	
Static torque	[Nm]	7000
max. admissible speed	[1/min]	1800
Torsional stiffness	[Nm/rad]	25400
Connection drive side	engine housing connection	D170 h6
	flywheel connection	D145 6x60°
Connection driven side	Shaft-Ø 70mm / Key	
Outer diameter	[mm]	475
Length	[mm]	380
Weight	[kg]	185
Actuation method	pneumatic	

Customer specific features:

- Radial compressed air supply
- High power density due to compact disk design
- Integrated sensor for RPM detection

Stromag – Clutches and Brakes

2in1 – Clutch and Coupling Combination

3 Non-Enclosed 2in1 Solution for PTO/PTI drives

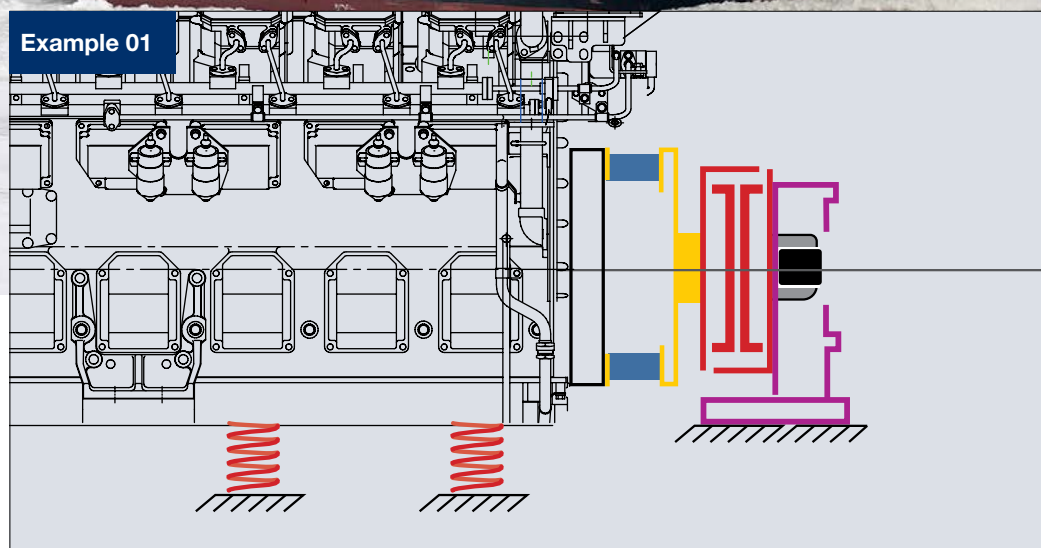

The standards includes:

- Internal engine, flexible installation
- Stand-alone design
- Integrated stand for mounting the work machine, stand-alone version

Stromag – Clutches and Brakes

2in1 – Clutch and Coupling Combination

Example application: Compact 2in1 solution, consisting of our flexible coupling, TEF and electromagnetic pole-face friction clutch, MWU for connecting and disconnecting PTO/PTI units, e.g. hydraulic pump.

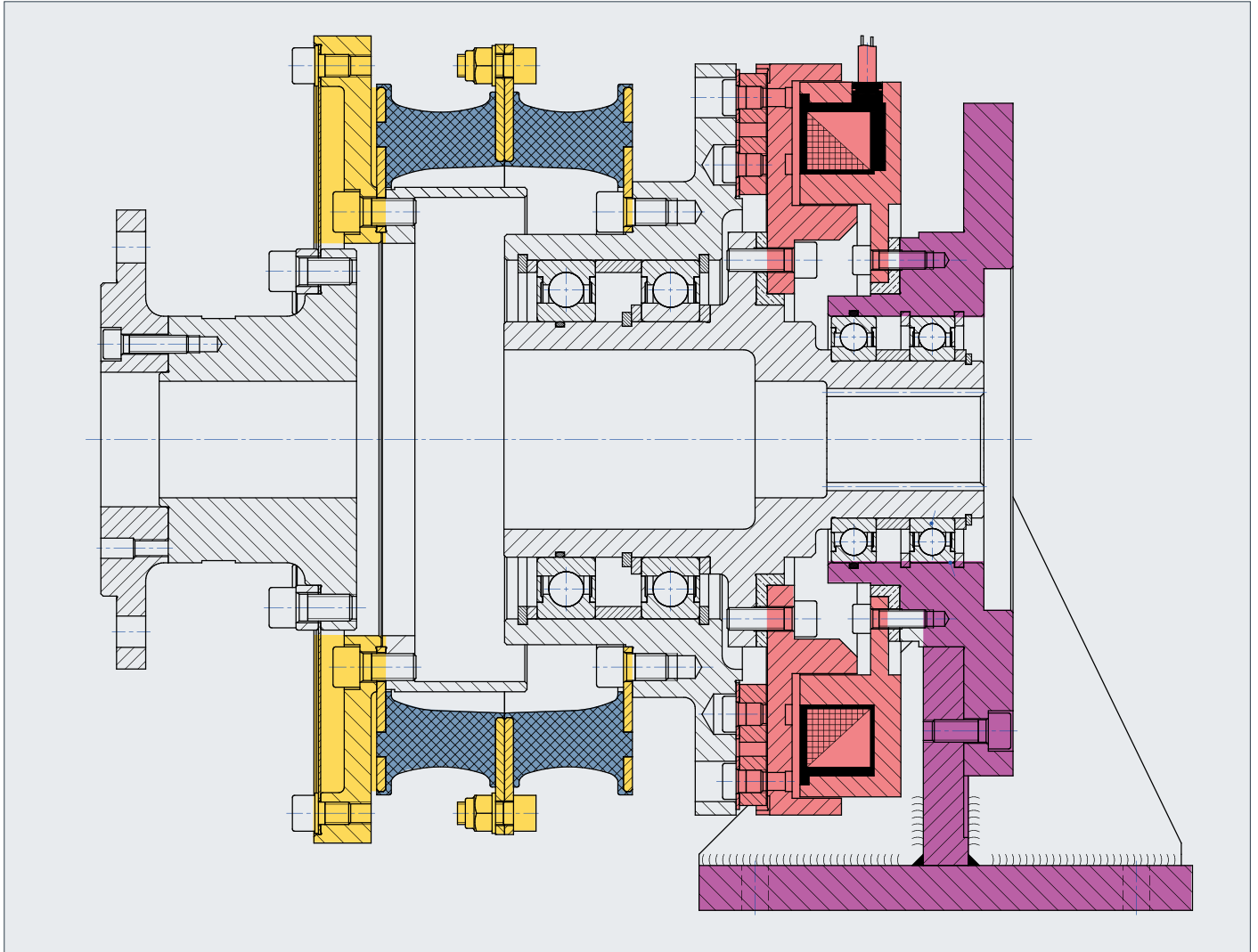

Technical data		
2in1 combination	MWU 80-200 TEF 311	
Static torque	[Nm]	2600
max. admissible speed	[1/min]	2000
Torsional stiffness	[Nm/rad]	6900
Connection drive side	engine housing connection	Flange / pitch circle diameter 171,45 mm
	flywheel connection	
Connection driven side	Shaft-Ø 38,25mm / gearing ANSI B92.1 DP8/16 13 teeth	
Outer diameter	[mm]	335
Length	[mm]	406,7
Weight	[kg]	131,6
Actuation method	engaged by electrical	

Customer specific features:

- Adapted pump connection on the stand
- In addition to torsional vibration damping, radial, axial and angular displacement permitted
- Deactivation of the output with almost no residual torque
- Easy installation in drivetrain

Stromag – Clutches and Brakes

2in1 – Clutch and Coupling Combination

3 Non-enclosed 2in1 Solution for hybrid drives

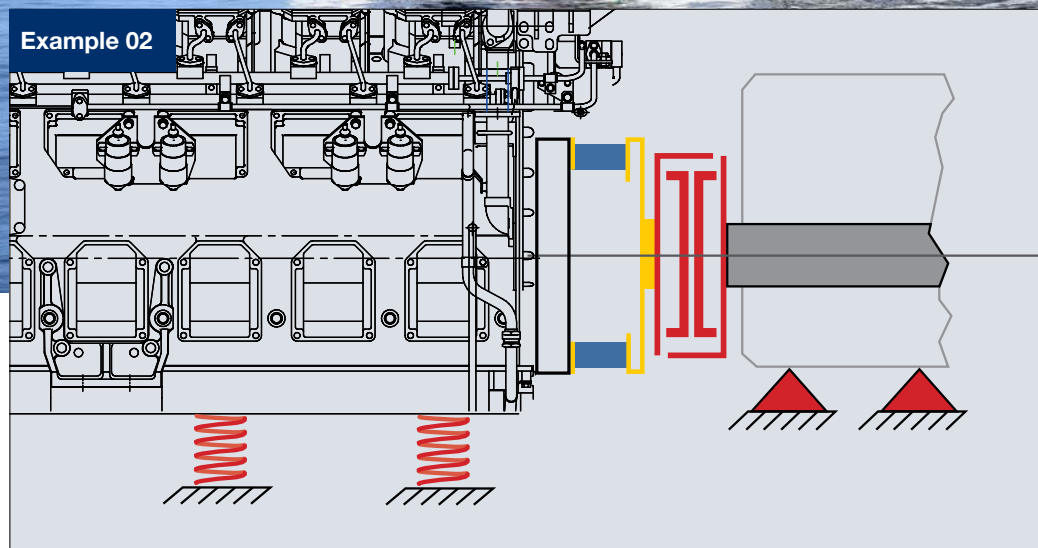

The standards includes:

- Internal combustion engine, flexible installation
- Flexible adaptation options
- Easy accessibility

Stromag – Clutches and Brakes

2in1 – Clutch and Coupling Combination

Example application: Compact 2in1 solution consisting of our flexible coupling, TRI and electromagnetic pole-face friction clutch, MWU for connecting and disconnecting hybrid drives, such as electric motors and generators.

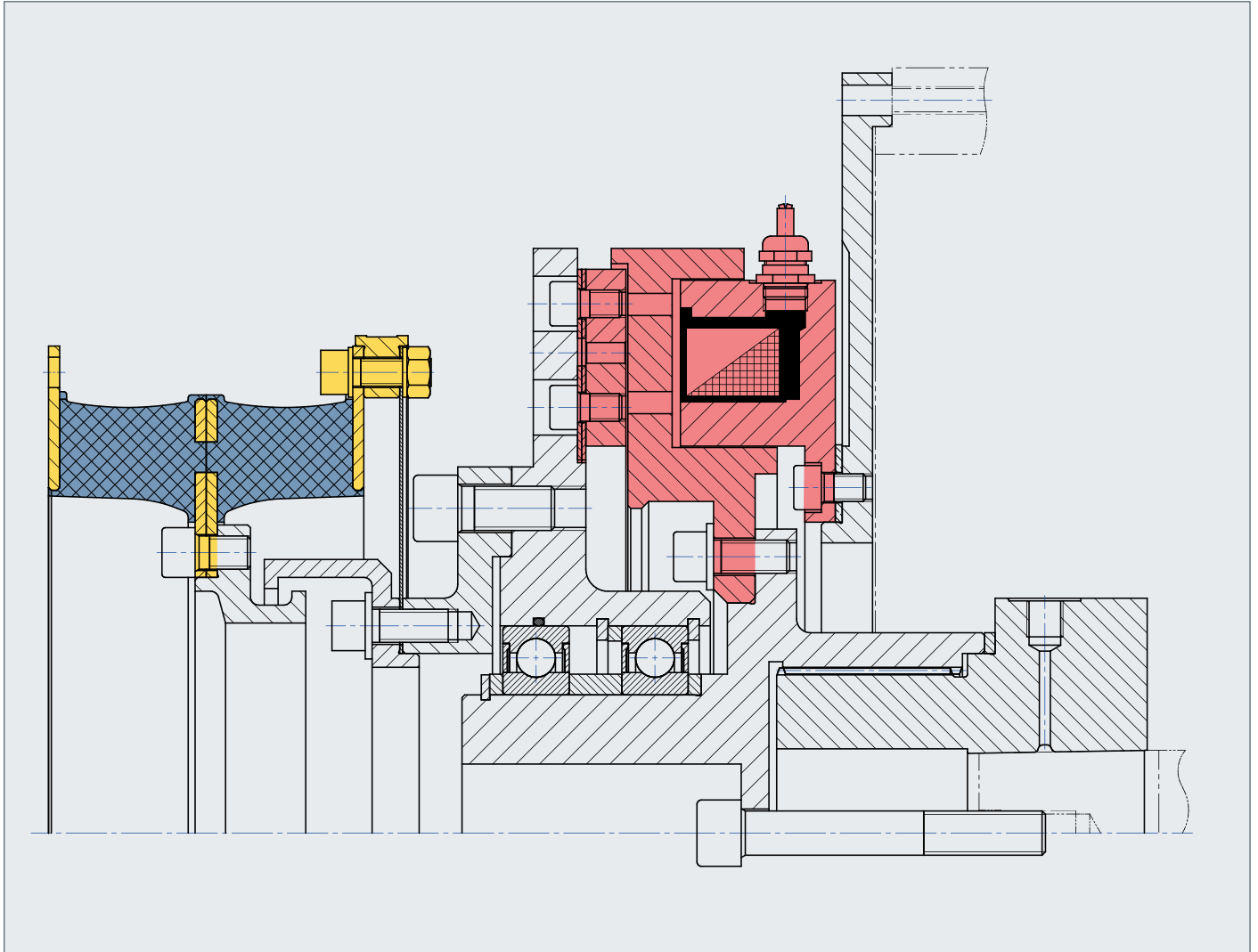

Technical data		
2in1 combination	MWU 160-400 TEF 322	
Static torque	[Nm]	5200
max. admissible speed	[1/min]	2600
Torsional stiffness	[Nm/rad]	14500
Connection drive side	engine housing connection	SAE 1
	flywheel connection	SAE 11,5"
Connection driven side	Shaft-Ø 60mm / Tapered connection	
Outer diameter	[mm]	550
Length	[mm]	397,3
Weight	[kg]	152,6
Actuation method	engaged by electrical current	

Customer specific features:

- In addition to torsional vibration damping, radial, axial and angular displacement permitted.
- Deactivation of the output with almost no residual torque

Stromag – Clutches and Brakes

2in1 – Clutch and Coupling Combination

4 Simple 2in1 Solution for PTO/PTI drives



The standards includes:

- Flexible coupling for compensating radial, axial and angular displacements between drive and work machine
- Shaft-shaft variant
- Integrated stand for mounting the work machine, stand-alone version

Stromag – Clutches and Brakes

2in1 – Clutch and Coupling Combination

Example application: Compact 2in1 solution, consisting of our flexible coupling, Periflex® NA and electromagnetic pole-face friction clutch, MWU for connecting and disconnecting PTO/PTI units, e.g. compressor.

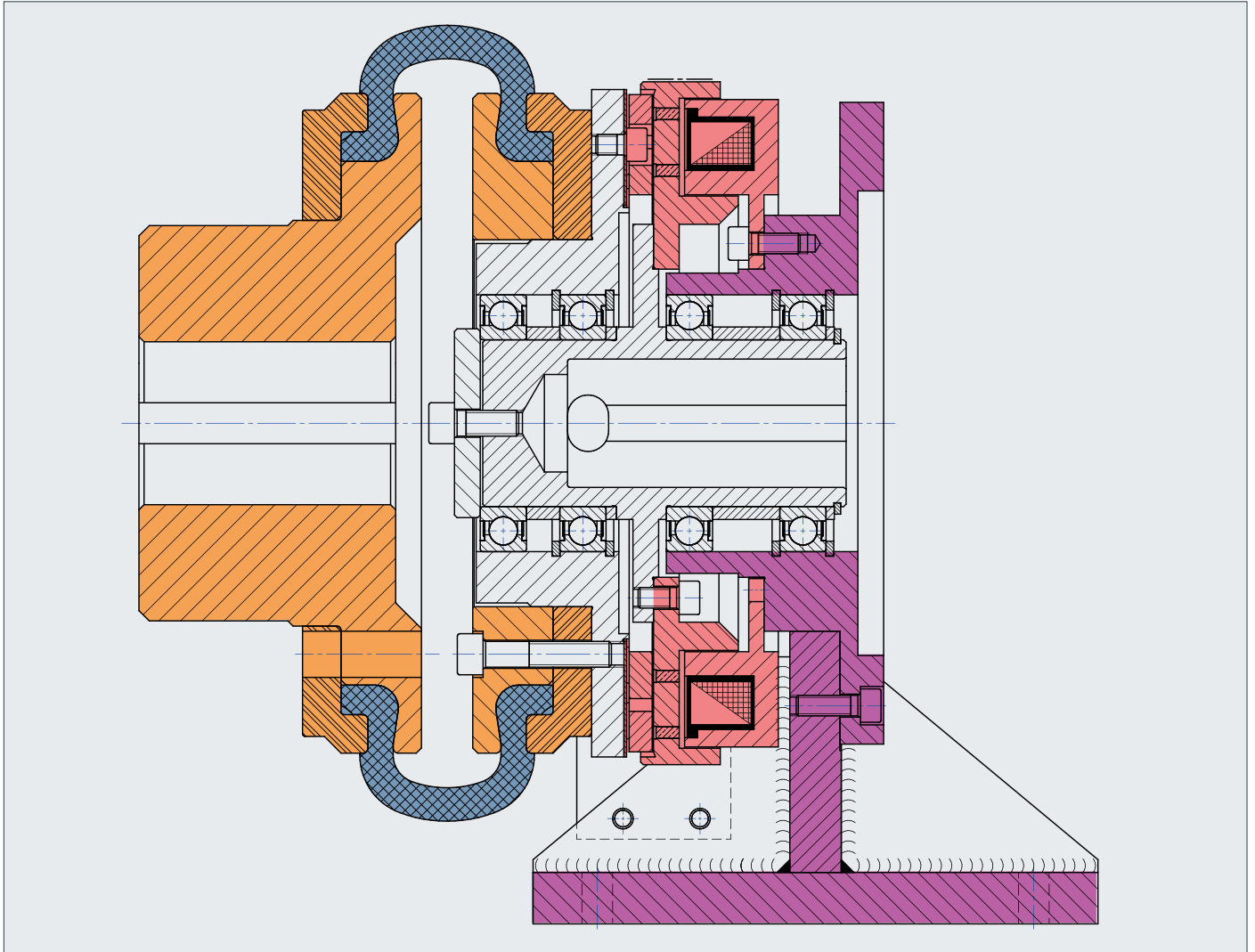

Technical data		
2in1 combination	MWU 40-100 Periflex®TT 310 R	
Static torque	[Nm]	1300
max. admissible speed	[1/min]	1800
Torsional stiffness	[Nm/rad]	18500 - 25500
Connection drive side	engine housing connection	Shaft Ø 63,475 H7 / Key
	flywheel connection	
Connection driven side	Shaft-Ø 50mm / Key	
Outer diameter	[mm]	310
Length	[mm]	290
Weight	[kg]	84,1
Actuation method	engaged by electrical current	

Customer specific features:

- Adapted pump connection on the stand
- Radial, axial and angular displacement permitted.
- Deactivation of the output with almost no residual torque
- Easy installation in drivetrain

STROMAG FACILITIES

EUROPE

Germany

Hansastraße 120
59425 Unna - Germany
+49 (0) 23 03 102 0

Clutches & Brakes, Couplings,
Geared Cam Limit Switches,
Discs

France

Avenue de l'Europe
18150 La Guerche sur L'Aubois
- France
+33 (0)2 48 80 72 72

Disc Brakes & Drum Brakes

Great Britain

Amphill Road
Bedford, MK42 9RD - UK
+44 (0)1234 324347

Electromagnetic Clutches
& Brakes, Industrial Caliper
Brakes

NORTH AMERICA

USA

31 Industrial Park Road
New Hartford, CT 06057 - USA
860-238-4783

Electromagnetic Clutches &
Brakes

300 Indiana Highway 212
Michigan City, IN 46360 - USA
219-874-5248

Couplings

2800 Fisher Rd.
Wichita Falls, TX 76302 - USA
940-723-3400

Geared Cam Limit Switches,
Industrial Caliper & Drum Brakes

SOUTH AMERICA

Brasil

Avenida João Paulo Ablas,
2970 Jardim da Glória, Cotia - SP,
06711-250 - Brasil
+55 (11) 4615-6300

Flexible Couplings, Bearing
Isolators, and Coupling Guards

ASIA PACIFIC

China

T40B -5, No. 1765
Chuan Qiao Road
Pudong 201206, Shanghai - China
Tel +86 21-60580600

Clutches & Brakes, Electro-
magnetic Clutches & Brakes,
Couplings, Industrial Caliper &
Drum Brakes, Discs, Geared Cam
Limit Switches

India

Gat No.: 448/14, Shinde Vasti,
Nighoje Tal Khed, Pune- 410 501
+91 2135 622100

Clutches & Brakes, Electromag-
netic Clutches & Brakes, Cou-
plings, Industrial Caliper & Drum
Brakes, Discs, Geared Cam Limit
Switches, Wind Brakes

RENEWABLE ENERGY

Denmark

Jernbanevej 9
5882 Vejstrup
+45 63 255 255
Wind Brakes

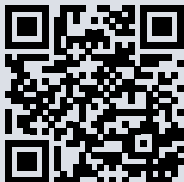

Scan to
see all the
brands
of Regal
Rexnord

Neither the accuracy nor completeness of the information contained in this publication is guaranteed by the company and may be subject to change in its sole discretion. The operating and performance characteristics of these products may vary depending on the application, installation, operating conditions and environmental factors. The company's terms and conditions of sale can be viewed at <http://www.altramotion.com/terms-and-conditions/sales-terms-and-conditions>. These terms and conditions apply to any person who may buy, acquire or use a product referred to herein, including any person who buys from a licensed distributor of these branded products.

©2023 by Stromag LLC. All rights reserved. All trademarks in this publication are the sole and exclusive property of Stromag LLC or one of its affiliated companies.

