



**VECTOR® COUPLINGS**





# DECADES OF EXPERIENCE

Across Industries and Applications



**Founded in 1932, Stromag™ has grown to become a globally recognized leader in the development and manufacture of innovative power transmission components for industrial drivetrain applications.**

Stromag engineers utilize the latest design technologies and materials to provide creative, energy-efficient solutions that meet their customer's most challenging requirements.

Stromag's extensive product range includes flexible couplings, disc brakes, limit switches, an array of hydraulically, pneumatically, and electrically actuated brakes, and a complete line of electric, hydraulic and pneumatic clutches.

Stromag engineered solutions improve drivetrain performance in a variety of key markets including energy, off-highway, metals, marine, transportation, printing, textiles, and material handling on applications such as wind turbines, conveyor systems, rolling mills, agriculture and construction machinery, municipal vehicles, forklifts, cranes, presses, deck winches, diesel engines, gensets and stage machinery.

VISIT US ON THE WEB AT **STROMAG.COM**



# CONTENT

VECTOR® COUPLINGS: IV

<b>COUPLING AT A GLANCE</b>	<b>4</b>
Product range	
Torque Range	
Classifications	
Instruction for the designer	
Benefits include	
The torsional vibration analysis	
Stromag Vector® technical data	<b>6</b>
Series: VMF...W-K	<b>8</b>
Series: VMF...W-L	<b>9</b>
Series: VMF...W	<b>10</b>
Custom-built model	<b>11</b>

# FLEXIBLE COUPLINGS

## COUPLING AT A GLANCE

### VECTOR® COUPLINGS PRODUCT RANGE

#### VMF...W-K SERIES

Nominal torque range 6600 – 22,500 Nm



Front perspective



Back perspective

#### VMW...W SERIES

Nominal torque range 6600 – 22,500 Nm



Front perspective



Back perspective

### CLASSIFICATIONS



For survey of the coupling by a classification society, the regulations of the society have to be adhered to. The coupling characteristics may differ from the definitions given in this catalogue. Accordingly prepared data sheets are available on request. A number of classification societies prescribe fail-safe devices on ships main drives.

### TORQUE RANGE

- 6600 up to 22,500 Nm

### INSTRUCTION FOR THE DESIGNER

All metal parts of the Stromag Vector® Coupling are made of steel or GGG.

The individual rubber elements can be mounted radially and can be connected to the coupling parts by bolted joints. The transmitted torque causes a tensile strain in the elements which is absorbed by the vulcanized nylon fabric inserts. Smooth running by coupling operation and less rotating radial forces are obtained by selection and arrangement of the single rubber elements according to their tensile characteristic curve.

Suitably stored, rubber flexible elements maintain their characteristics for several years without change. The parts need to be stored against oxygen, ozone, heat, light, moisture and solvents. The temperature in the store should be between +10°C und +25°C.

The relative humidity should not exceed 65%. Further details can be taken from DIN 7716 and ISO 2230.

# FLEXIBLE COUPLINGS

## COUPLING AT A GLANCE

The new Stromag Vector® coupling represents the next logical and consistent step in the evolution of our tried and tested GE rubber fabric coupling – a flexible coupling that has become successfully established on the market.

The new Vector® coupling concept is based on the experience we have gained from the most diverse application fields.

The result is a coupling that connects two shafts free of backlash. The coupling features a radial arrangement of segments in a compact design. This facilitates installation

and removal without the need to displace the drive units.

The capability of the highly flexible Stromag Vector® coupling to displace in all directions makes it ideal for applications on engines mounted on both rigid and flexible bearings. The coupling also exhibits progressive characteristics for the optimal configuration of the drive unit's vibration behaviour.

Our experts will support you by TVA torsional vibrations analysis for your drivetrain.

### What can the Stromag Vector® do for you?

**It is very compact** because its rubber-fabric elements exhibit a high power density

**It minimizes your costs** because the special rubber-fabric elements enhance the service life of the Vector® coupling

**It saves valuable working time** because the elastomer elements radial mounting facilitates installation and removal without the need to displace the machine

**It adjusts to your needs** because it can displace in all directions and can be installed easily on engines mounted on both rigid and flexible bearings

**Add on features** compact design - outstanding ventilation - zero backlash - reduced installation times - low reactive forces



### Technical data

Vector coupling size	Nominal torque	Maximum torque		Adm. alternating torque	Adm. Speed	Adm. axial displacement	Axial stiffness	Adm. radial displacement
	$T_{KN}$ Nm	$T_{Kmax1}$ Nm 1)	$T_{Kmax2}$ Nm 2)	$T_{Kw}$ Nm	$n_{max}$ min <sup>-1</sup>	$\Delta K_a$ mm	$C_a$ kN/mm 3) 4)	$\Delta K_r$ mm 7)
V...20	6600	13200	19800	3300	2300	8	0,56	4
V...30	9900	19800	29700	4950	2300	8	0,84	4
V...40	15000	30000	45000	7500	1800	9	0,85	5
V...50	22500	45000	67500	11300	1800	9	1,3	5

1) for transient repetitive vibrations during start / stop, clutching etc.

2) for rare occasional peak loads, e. g. short circuits in generators

3) Tolerances until  $\pm 15\%$  related to the material are possible.

4) At torque  $T_{KN}$

5) For:  $T_w = 0.2 \cdot T_{KN}$ ;  $f = 10 \text{ Hz}$ ;  $\vartheta = 30^\circ\text{C}$

### THE TORSIONAL VIBRATION ANALYSIS



Stromag's Know-how in Torsional Vibration Analysis (TVA) constitutes the core of each coupling design. It provides a comprehensive analysis of loads in the crankshaft, coupling and driven side to ensure that no critical speeds occur during operation.

Unevenly rotating systems can severely degrade product quality and cause great harm to the powertrain. On a daily basis, the TVA experts at Stromag work on the challenge of detecting such deviations by measuring them and protecting the entire powertrain with ideal product selection. Stromag is capable of calculating stationary and transient operating conditions considering the stiffness and damping of the elastomers.

Adm. radial displacement	Radial stiffness	Torsional stiffness, depending on the preload					Relative damping	Adm. dumping power
$\Delta K_{r \max}$ mm	$C_r$ kN/mm 3) 4)	$C_{t \text{ dyn}}$ kNm/rad 3) 5)					$\Psi$ 3) 5)	$P_{KV60}$ 8)
		$T_{KN} \leq 0$ 6)	$0,2 \times T_{KN}$	$0,4 \times T_{KN}$	$0,8 \times T_{KN}$	$1,0 \times T_{KN}$		
8	1,6	24	62	144	206	234	0,8	840
8	2,4	36	93	216	310	352	0,8	1260
10	2,6	48	138	364	527	610	0,8	1000
10	3,9	72	207	546	790	915	0,8	1500

6) This value is constant for the torque range from 0 to  $-0,3 \cdot T_{KN}$

7) At  $n_{\max} = 600 \text{ rpm}$ , for higher speed ratings:

$$\Delta K_r(n) = \sqrt{\frac{600 \text{ min}^{-1}}{n}} \cdot \Delta K_r$$

8) The value  $P_{KV60}$  describes the damping power to be absorbed over 60 minutes. Permanently absorbed damping power  $P_{KV\infty} = 0,5 \cdot P_{KV60}$ .

# FLEXIBLE COUPLINGS

## Stromag Vector® Couplings

Series: VMF..W-K

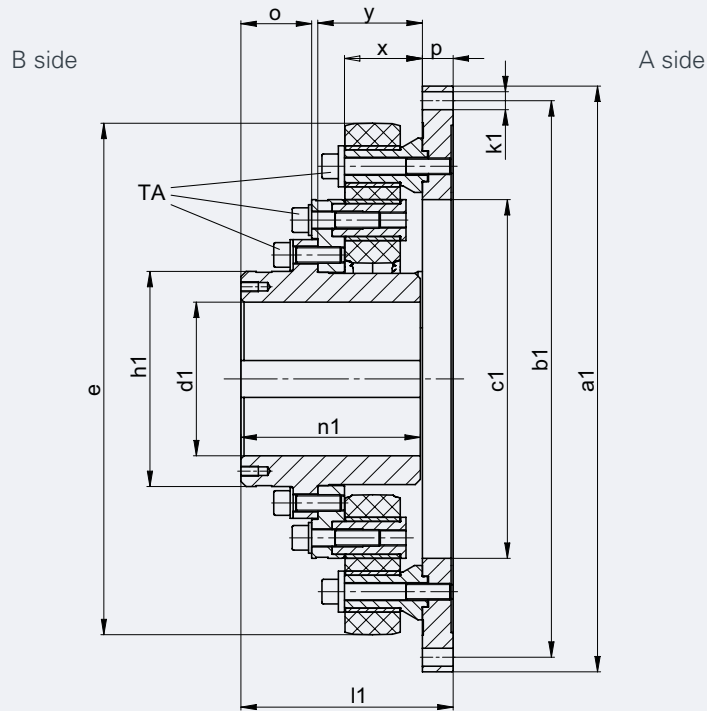

Coupling size	VMF 20 W 14"-K	VMF 20 W 18"-K	VMF 30 W 14"-K	VMF 30 W 18"-K	VMF 40 W 21"-K	VMF 40 W 24"-K	VMF 50 W 21"-K	VMF 50 W 24"-K
<b>Diameter</b>								
a1	466,7	571,5	466,7	571,5	673,1	733,4	673,1	733,4
b1	438,2	542,9	438,2	542,9	641,4	692,2	641,4	692,2
c1	350	350	350	350	480	480	480	480
e	499	499	499	499	660	660	660	660
h1	210	210	210	210	270	270	270	270
d1 <sub>max</sub>	150	150	150	150	190	190	190	190
k1	8x 13,5	6x 17,5	8x 13,5	6x 17,5	12x 17,5	12x 20	12x 17,5	12x 20
<b>Lengths: mm</b>								
l1	207	207	207	207	262	262	262	262
n1	175	175	175	175	220	220	220	220
o	69	69	69	69	88	88	88	88
p	30	30	30	30	42	42	42	42
x	76	76	76	76	94	94	94	94
y	102	102	102	102	126	126	126	126
<b>Mass: kg</b>								
m *	67,4	84,8	71,9	89,3	160	172	168	180
<b>Mass mom.of inertia: kgm<sup>2</sup></b>								
JA side	1,001	2,225	1,109	2,333	5,133	6,683	5,497	7,047
JB side*	0,627	0,627	0,677	0,677	2,550	2,550	2,712	2,712

\*) At max. bore dia.

Other coupling sizes on request



# FLEXIBLE COUPLINGS

## Stromag Vector® Couplings

Series: VMF...W-L

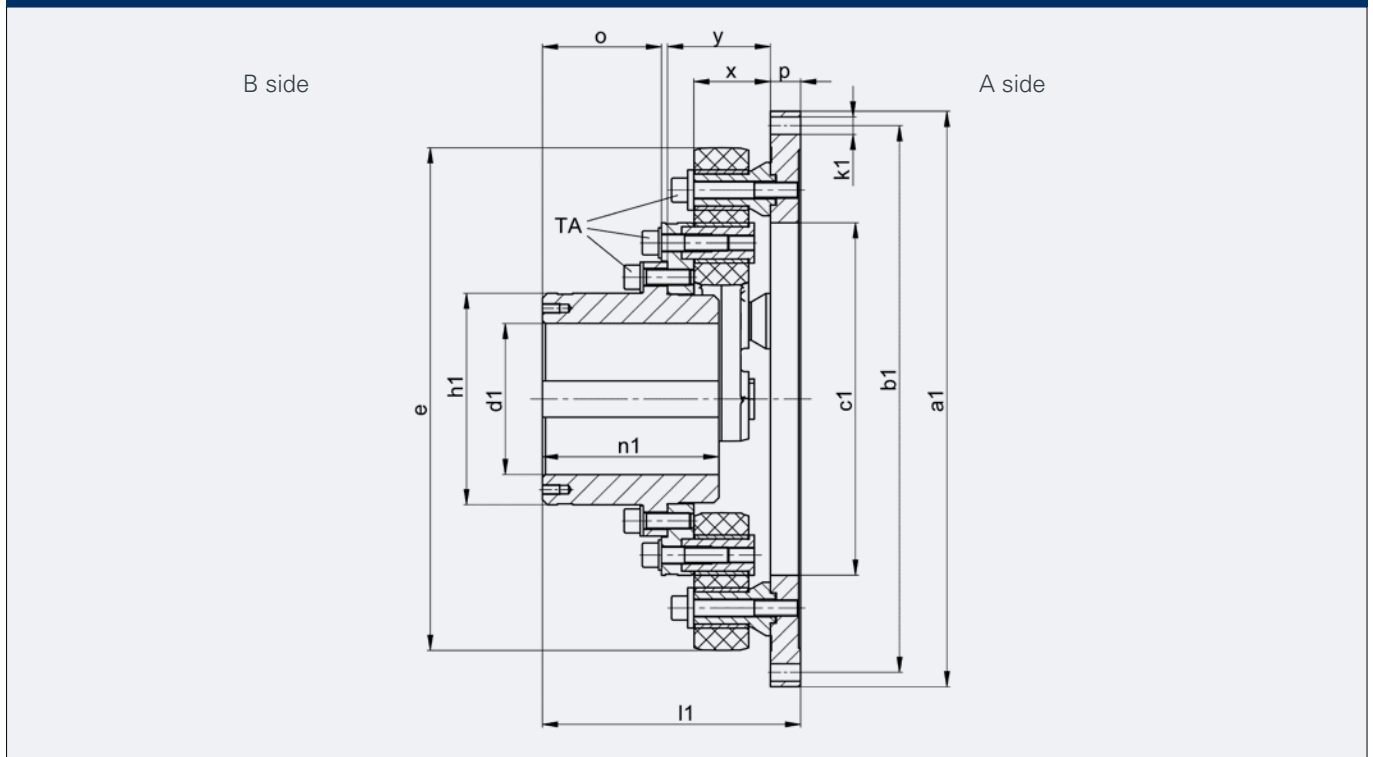

Coupling size	VMF 20 W 14"-L	VMF 20 W 18"-L	VMF 30 W 14"-L	VMF 30 W 18"-L	VMF 40 W 21"-L	VMF 40 W 24"-L	VMF 50 W 21"-L	VMF 50 W 24"-L
<b>Diameter: mm</b>								
a1	466,7	571,5	466,7	571,5	673,1	733,4	673,1	733,4
b1	438,2	542,9	438,2	542,9	641,4	692,2	641,4	692,2
c1	350	350	350	350	480	480	480	480
e	499	499	499	499	660	660	660	660
h1	210	210	210	210	270	270	270	270
d1 <sub>max</sub>	150	150	150	150	190	190	190	190
k1	8x 13,5	6x 17,5	8x 13,5	6x 17,5	12x 17,5	12x 20	12x 17,5	12x 20
<b>Lengths: mm</b>								
l1	256	256	256	256	324	324	324	324
n1	175	175	175	175	220	220	220	220
o	118	118	118	118	150	150	150	150
p	30	30	30	30	42	42	42	42
x	76	76	76	76	94	94	94	94
y	102	102	102	102	126	126	126	126
<b>Mass: kg</b>								
m *	67,9	85,3	72,4	89,8	161	173	169	181
<b>Mass mom.of inertia: kgm<sup>2</sup></b>								
JA side	1,001	2,225	1,109	2,333	5,133	6,683	5,497	7,047
JB side *	0,632	0,632	0,682	0,682	2,565	2,565	2,727	2,727

\*) at max. bore dia.

Other coupling sizes on request

# FLEXIBLE COUPLINGS

## Stromag Vector® Couplings

Series: VMW...W

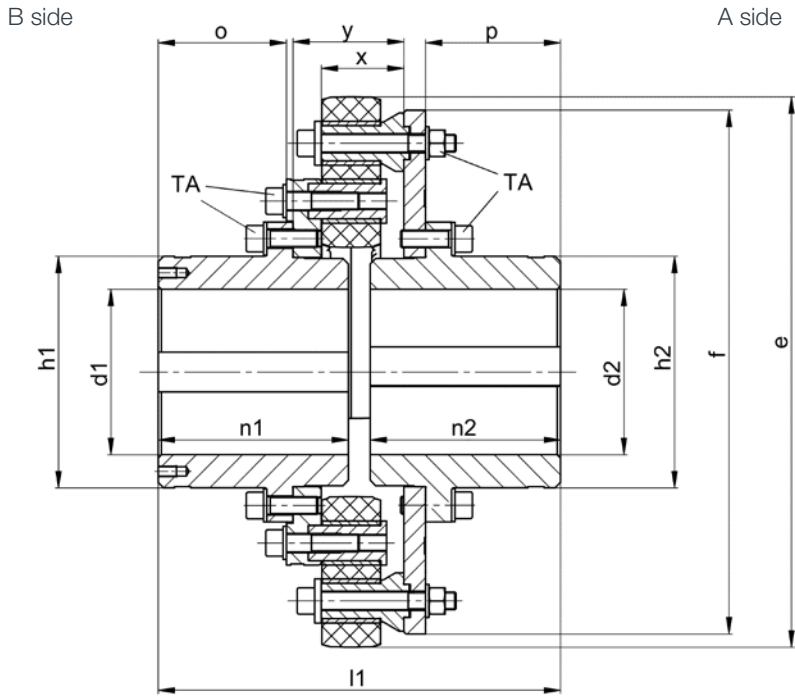

Coupling size	VMW 20 W	VMW 30 W	VMW 40 W	VMW 50 W
<b>Diameter: mm</b>				
e	499	499	660	660
f	475	475	654	654
h1	210	210	270	270
h2	210	210	270	270
d1 max	150	150	190	190
d2 max	150	150	190	190
<b>Lengths: mm</b>				
l1	370	370	464	464
n1	175	175	220	220
n2	175	175	220	220
o	118	118	158	150
p	124	124	172	156
x	76	76	94	94
y	102	102	126	126
<b>Mass: kg</b>				
m*	100	105	226	234
<b>Mass mom. of inertia: kgm<sup>2</sup></b>				
JA side*	1,245	1,359	5,240	5,626
JB side*	0,632	0,682	2,565	2,727

\*) at max. bore dia.

# FLEXIBLE COUPLINGS

## Stromag Vector® Couplings

### custom-built model

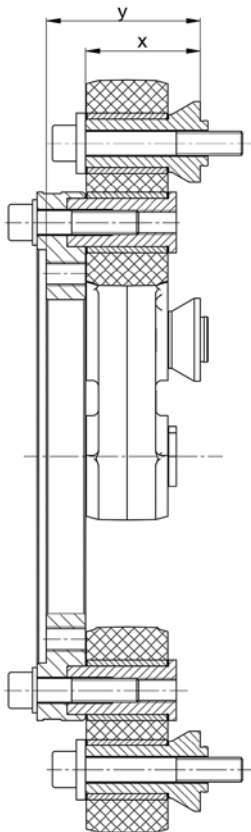
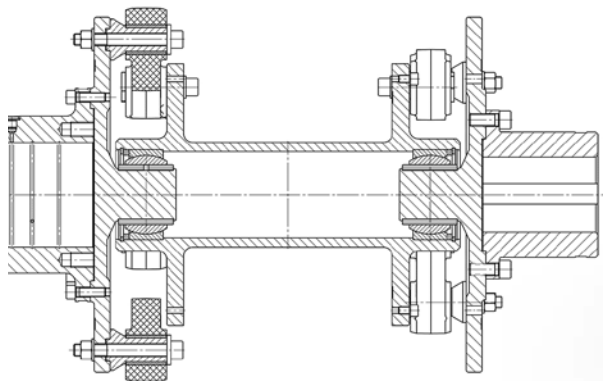



## **Regal Rexnord**

[regalrexnord.com](https://www.regalrexnord.com)

### **Stromag GmbH**

Hansatraße 120

59425 Unna - Germany

+49 2303 102 - 0

[Stromag.com](https://www.stromag.com)

The proper selection and application of products and components, including assuring that the product is safe for its intended use, are the responsibility of the customer. To view our Application Considerations, please visit <https://www.regalrexnord.com/Application-Considerations>.

To view our Standard Terms and Conditions of Sale, please visit <https://www.regalrexnord.com/Terms-and-Conditions-of-Sale>.

"Regal Rexnord" is not indicative of legal entity. Refer to product purchase documentation for the applicable legal entity.

Regal Rexnord and Stromag are trademarks of Regal Rexnord Corporation or one of its affiliated companies.

©2024 Regal Rexnord Corporation, All Rights Reserved.  
MCC-P-8363-SG A4-EN 08/24

The Regal Rexnord logo, featuring a stylized icon to the left of the words "Regal Rexnord" in a bold, sans-serif font with a trademark symbol.