

# CENTAX-SEC Series L 100

Assembly and operating instructions

CX-176...184-LFS2-200

M39-002-EN

Rev. 1

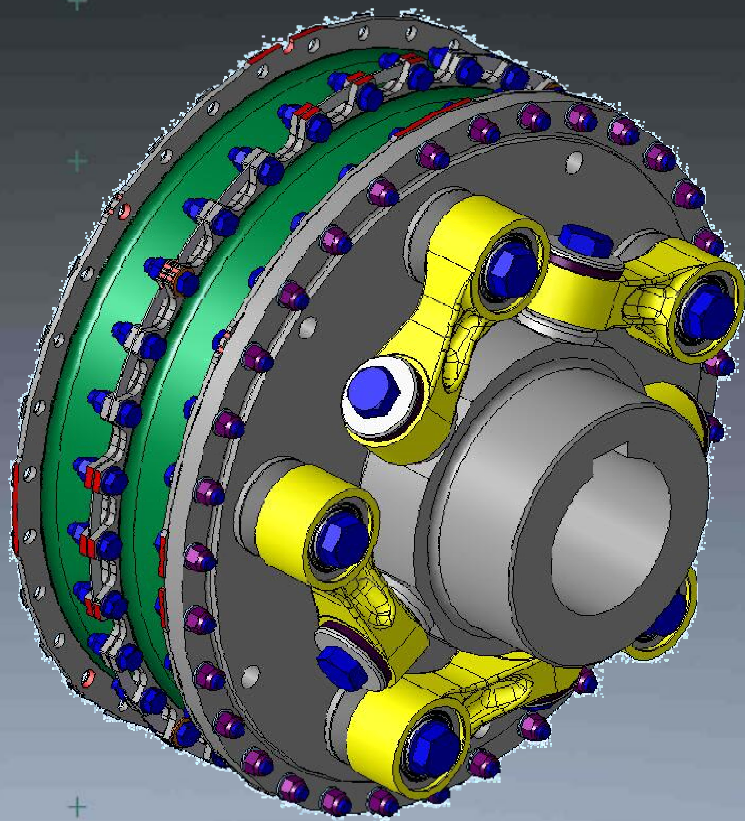

Power Transmission  
Leading by innovation



**Contents**

- 1 General remarks ..... 5**
- 2 Safety ..... 6**
  - 2.1 Safety remarks..... 6
    - 2.1.1 Signal words..... 6
    - 2.1.2 Pictograms ..... 7
  - 2.2 Qualification of deployed personnel ..... 7
  - 2.3 Intended application..... 7
  - 2.4 Application not in compliance with the intended use..... 9
- 3 Delivery, transport, storage and disposal ..... 10**
  - 3.1 Delivery..... 10
  - 3.2 Transport..... 10
  - 3.3 Storage ..... 10
    - 3.3.1 Storage location..... 11
    - 3.3.2 Storage of couplings / flexible elements..... 11
  - 3.4 Disposal ..... 11
- 4 Technical description ..... 12**
  - 4.1 Characteristics..... 12
  - 4.2 Specifications ..... 12
- 5 Alignment of the units being connected..... 13**
  - 5.1 Axial alignment..... 13
  - 5.2 Radial alignment..... 14
  - 5.3 Angular alignment..... 16
- 6 Mounting ..... 18**
  - 6.1 General assembly instructions ..... 18
  - 6.2 Mounting the hub..... 20
    - 6.2.1 Mounting the hub with feather key..... 20
    - 6.2.2 Mounting the hub with oil interference fit ..... 22
  - 6.3 Aligning the units..... 24
  - 6.4 Positioning the flange onto the hub..... 25
  - 6.5 Positioning the rubber element assembly and the ventilation plate ..... 26
  - 6.6 Mounting the rubber element assembly to the flywheel ..... 27
  - 6.7 Mounting the rubber element assembly to the flange ..... 28
  - 6.8 Mounting size 3 and 4 links ("ccw" / "cw" rotation) ..... 30
  - 6.9 After completed mounting..... 33
- 7 Operation..... 34**
  - 7.1 Operating faults, root causes and remedy..... 34
  - 7.2 Admissible overall misalignment of the coupling ..... 35



<b>8</b>	<b>Care and maintenance .....</b>	<b>36</b>
8.1	Work to be performed .....	36
8.1.1	Cleaning the coupling.....	36
8.1.2	Visual inspection of the coupling.....	36
8.1.3	Visual inspection of links .....	36
8.1.4	Visual inspection of the rubber elements / rubber segments .....	37
8.1.5	Inspection of the screw connections.....	37
8.2	Replacing defective parts .....	37
<b>9</b>	<b>Dismantling .....</b>	<b>38</b>
9.1	General dismantling instructions .....	38
9.2	Dismantling the links.....	39
9.3	Dismantling the rubber element assembly from the flange.....	39
9.4	Dismantling the rubber element assembly and the ventilation plate from the flywheel.....	39
9.4.1	Removing the mounting supports .....	39
9.5	Dismantling the flange.....	39
9.6	Dismantling the hub.....	39
9.6.1	Dismantling the hub with feather key .....	40
9.6.2	Dismantling the hub with oil interference fit .....	40
9.7	Reassembling the coupling .....	41
<b>10</b>	<b>Wearing and spare parts.....</b>	<b>42</b>
<b>11</b>	<b>Annex .....</b>	<b>43</b>
11.1	CENTA data sheet D13-013 (lubricated screw connections) .....	43



**Index of illustrations**

Fig. 5-1 Axial misalignment..... 13  
Fig. 5-2 Radial misalignment ..... 14  
Fig. 5-3 Angular misalignment..... 16  
Fig. 6-1 Mounting the hub with feather key ..... 21  
Fig. 6-2 Mounting the hub with oil interference fit..... 22  
Fig. 6-3 Positioning the flange onto the hub..... 25  
Fig. 6-4 Positioning the rubber element assembly and the ventilation plate ..... 26  
Fig. 6-5 Mounting the rubber element assembly to the flywheel..... 27  
Fig. 6-6 Mounting the rubber element assembly to the flange ..... 28  
Fig. 6-7 Mounting size 3 and 4 links ("ccw" counterclockwise rotation) ..... 31  
Fig. 6-8 Mounting size 3 and 4 links ("cw" clockwise rotation) ..... 31

**Index of tables**

Table 2-1 Shape and size of ventilation holes..... 8  
Table 5-1 Permissible radial alignment tolerance ..... 15  
Table 5-2 Permissible angular alignment tolerance ..... 17  
Table 6-1 Guide to links Size 3 and 4..... 30  
Table 7-1 Troubleshooting table..... 34



## **1 General remarks**

These assembly and operating instructions form a constituent part of the coupling delivery and must be kept in an easily accessible place at all times.

CENTA products are developed and produced to quality standard DIN EN ISO 9001:2000.

In the interests of further development, CENTA reserves the right to make technical changes.



### **IMPORTANT**

CENTA is unable to accept liability for damage and operating faults caused by failure to observe the operating instructions.

These operating instructions are protected under copyright to CENTA Antriebe Kirschey GmbH.

In case of technical questions, please enquire with our head office:

**CENTA Antriebe  
Kirschey GmbH**  
Bergische Strasse 7  
42781 Haan  
GERMANY  
Phone +49-2129-912-0  
Fax +49-2129-2790  
centa@centa.de  
www.centa.info

## 2 Safety

The purpose of these operating instructions is to enable users to:

- use the coupling safely and correctly
- maximize efficiency
- ensure that care and maintenance are carried out correctly

For this reason, these operating instructions must be thoroughly read and understood prior to work on and with the coupling.

### WARNING



#### **Injury and material damage can occur as a result of:**

- Failure to adhere to the safety and accident prevention regulations valid at the relevant installation site

The safety and accident prevention regulations valid at the installation site in question must be adhered to when performing any of the tasks described in these operating instructions.

### 2.1 Safety remarks

In these operating instructions, safety remarks are indicated by a pictogram and a signal word.

#### 2.1.1 Signal words

The following signal words are used in the safety remarks:

**DANGER**

Denotes the immediate threat of danger.

If not prevented, fatal or extremely serious injuries can result.

**WARNING**

Denotes a potentially dangerous situation.

If not prevented, fatal or extremely serious injuries can result.

**CAUTION**

Denotes a potentially dangerous situation.

If not prevented, minor injuries and/damage to property may result.

**IMPORTANT**

Denotes application tips and particularly useful information. This is not a signal word denoting a dangerous or damaging situation.

### 2.1.2 Pictograms

Possible pictograms in the safety precautions:



Warning of a hazardous area



Do not switch



Use protective gloves



Use protective goggles

### 2.2 Qualification of deployed personnel

All the work described in these operating instructions may only be performed by authorized persons with adequate training and instruction.

<b>WARNING</b>	
	<p><b>Injury and material damage can occur as a result of:</b></p> <ul style="list-style-type: none"> <li>▪ Work at the coupling which is not described in these instructions</li> </ul> <p>Only carry out work which is described in these operating instructions.</p>

### 2.3 Intended application

<b>WARNING</b>	
	<p><b>Injury and material damage can occur as a result of:</b></p> <ul style="list-style-type: none"> <li>▪ Application not in compliance with the intended use</li> </ul> <p>The couplings are intended exclusively for use in accordance with the relevant design. They may only be used under the specified conditions.</p>

**WARNING**



**Injuries can occur as a result of:**

- Contact with rotating parts

Shield the coupling in accordance with the applicable accident prevention regulations with an enclosure.

**Exception:**

The coupling is encased by the driving and driven units.

**The scope of delivery provided by CENTA does not include a protective enclosure.**

This enclosure must fulfil the following criteria:

- Provide protection against persons gaining access to rotating parts
- Restrain any rotating parts which may be work loose
- Guarantee sufficient ventilation for the coupling

This enclosure must be made of stable steel components. In order to ensure adequate ventilation for the coupling, the enclosure must be fitted with regular openings. For safety reasons, these openings must not exceed the dimensions outlined in table 2-1.

<b>Component</b>	<b>Circular openings [mm]</b>	<b>Rectangular openings [mm]</b>
Top of the enclosure	Ø 8	□ 8
Side elements of the enclosure	Ø 8	□ 8

*Table 2-1 Shape and size of ventilation holes*

The enclosures must be positioned a minimum of 15 mm distant from rotating parts. The enclosure must be electrically conductive and be included in the equipotential bonding.

Before commencing long-term operation, the plant must successfully complete a test run.



**2.4 Application not in compliance with the intended use**

<b>WARNING</b>	
	<p><b>Injury and material damage can occur as a result of:</b></p> <ul style="list-style-type: none"><li>▪ Inadmissibly high torque</li><li>▪ Inadmissibly high or low speeds</li><li>▪ Exceeding the specified ambient temperature</li><li>▪ Inadmissible ambient medium</li><li>▪ Inadmissible coupling enclosure</li><li>▪ Exceeding the admissible overall misalignment values</li></ul> <p>Only use the coupling for the specified application.</p>

CENTA bears no liability for damage resulting from application not in compliance with the intended use of the equipment.

Should there be a change of plant parameters, the coupling design must be reviewed by CENTA (address see chapter 1).

### 3 Delivery, transport, storage and disposal

#### 3.1 Delivery

After delivery, the coupling:

- must be checked for completeness and correctness of the delivery.
- must be examined for possible transport damage (which must be reported immediately to the carrier).

#### 3.2 Transport

<b>CAUTION</b>	
	<p><b>Injury and material damage can occur as a result of:</b></p> <ul style="list-style-type: none"><li>▪ Incorrect transportation of couplings</li></ul> <p>Ensure that the coupling is correctly transported.</p>

<b>CAUTION</b>	
	<p><b>Material damage to coupling components can occur as a result of:</b></p> <ul style="list-style-type: none"><li>▪ Contact with sharp-edged objects</li></ul> <p>Protect coupling components for transportation. Only hoist coupling components with nylon belts or ropes. Always cushion parts when supporting them from below.</p>

Following transportation damage:

- Check the coupling carefully for damage.
- Consult the manufacturer (Address see chapter 1).

#### 3.3 Storage

<b>CAUTION</b>	
	<p><b>Material damage to elastic elements and rubber parts can occur as a result of:</b></p> <ul style="list-style-type: none"><li>▪ Incorrect storage</li></ul> <p>These parts must be stored laid flat and so they cannot distort, and protected from ozone, heat, light, moisture and solvents.</p>

 <b>IMPORTANT</b>	
Rubber parts are marked where possible with their production date. From this date, they may only be stored for a maximum of 5 years.	

**3.3.1 Storage location**

Requirements imposed on the storage location:

- Moderately ventilated and low in dust
- Dry (max. 65% humidity)
- Temperature stabilized (-10°C to +25°C)
- Free of ozone-producing devices such as light sources and electric motors
- Free of UV light sources and direct sunlight
- Do not store solvents and disinfectants, fuels or lubricants, acids, chemicals etc. in the same location

For more details, refer to DIN 7716.

**3.3.2 Storage of couplings / flexible elements**

- Unpack the parts.
- Check the packaging for damage. Replace if necessary.
- Check that the wax protection on steel components is intact. If necessary, patch or renew.
- Package the parts (for prolonged periods of storage, enclose desiccant and weld into film).
- Place the parts into storage.

**3.4 Disposal**

<b>RECYCLING</b>	
	Ensure safe, environmentally responsible disposal of operating supplies and exchange parts. For this, locally provided recycling facilities and regulations must be utilized.

For disposal, the coupling parts must be separated where possible and sorted according to material type.



## **4 Technical description**

### **4.1 Characteristics**

The CENTAX-SEC series L coupling have the following excellent characteristics, due to the combination of a torsionally flexible CENTAX element and the CENTA link coupling with axial angular movement:

- Compensation of torsional vibrations and impacts without wear.
- Compensation of major axial, radial and angular displacement with minimal restoring forces.
- Silent operation and noise damping.
- Backlash free, torsionally rigid and radially rigid.
- Low-maintenance, free of wear.
- Easy visual inspection.
- Fast exchange of components.
- No special tools required.
- The design is protected by international patents.
- Type approval from leading classification agencies.
- Tried and tested thousands of times over in tough daily operation since 1992.

### **4.2 Specifications**

The specifications can be found in the catalogue and the dimensions in the installation drawing.

## 5 Alignment of the units being connected

### IMPORTANT

- Align the units during the assembly.
- Align the units that are to be connected as accurately as possible. In this way, a long service life for the coupling and maximum operating misalignment values can be achieved.  
The overall misalignment is composed of the misalignment and the operating misalignment. The permissible overall misalignment values can be found in the corresponding catalogue and must not be exceeded.
- All permissible alignment tolerances apply to arrangements at operating temperatures.  
If the arrangement would be aligned at a different temperature, there would be additional deviations in the arrangement, which were produced by the difference between the aligning and operating temperature.  
For alignment, this has to be taken into account.
- After completion of assembly, check the alignment of the coupling again and if necessary correct.

### 5.1 Axial alignment

Determine the axial misalignment (see Fig. 5-1).

- Take installation length **L** from the installation drawing.
- Align the units (installation dimension =  **$L \pm \Delta K_A \text{ max}$** ).

Permissible axial alignment tolerance:

**$\Delta K_A \text{ max} = 0.5 \text{ mm}$**

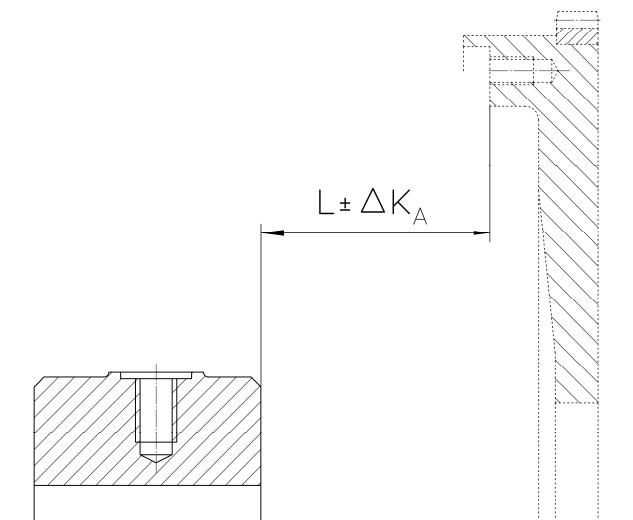

Fig. 5-1 Axial misalignment

## 5.2 Radial alignment

### CAUTION



**Material damage to elastically installed motors can occur as a result of:**

- Disregard during alignment of the extent by which the motor bearing settles

During vertical alignment, take into account the extent by which the motor bearing settles. Please enquire about specifications for the degree of settling from the motor manufacturer or motor bearing manufacturer.

Measure the radial misalignment with a dial gauge (see Fig. 5-2).

- Attach the dial gauge to the hub.
- Set the sensor of the dial gauge radially against the centering.
- Turn the hub with dial gauge and flywheel slowly by 360°.
- Align the units (calculated deviation  $\leq \Delta K_{R \max}$ ).

The permissible radial alignment tolerance  $\Delta K_{R \max}$  can be found in the following table.

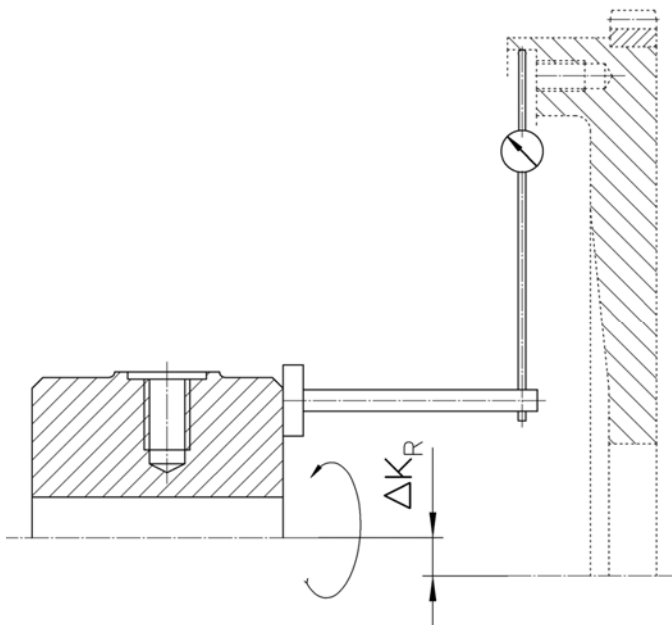

Fig. 5-2 Radial misalignment



Size	Shore hardness [Shore A]	$\Delta K_{R \max}$ [mm]
176	50 / 60	$\pm 1.65$
	70	$\pm 0.51$
177	50 / 60	$\pm 1.8$
	70	$\pm 0.6$
179	50 / 60	$\pm 2.1$
	70	$\pm 0,75$
181	50 / 60	$\pm 2.1$
	70	$\pm 0.75$
183	50 / 60	$\pm 2.25$
	70	$\pm 0.75$
184	50 / 60	$\pm 2.4$
	70	$\pm 0.75$
186	50 / 60	$\pm 2.4$
	70	$\pm 0.75$

Table 5-1 Permissible radial alignment tolerance

### 5.3 Angular alignment

Measure the angular misalignment with a dial gauge (see Fig. 5-3).

- Attach the dial gauge to the hub.
- Position the sensor of the dial gauge radially against flat surface at a distance  $R$ .
- Turn the hub with dial gauge and flywheel slowly by  $360^\circ$ .

The maximum dial gauge deflection must not exceed the value  $2xS_w$  at any point. The permissible tolerance  $S_{w \max}$  should be taken from the table below.

- Align the units (calculated deviation  $\leq \Delta K_w \max$ ).

Permissible angular alignment tolerance:

$$\Delta K_w \max = 0.2^\circ$$

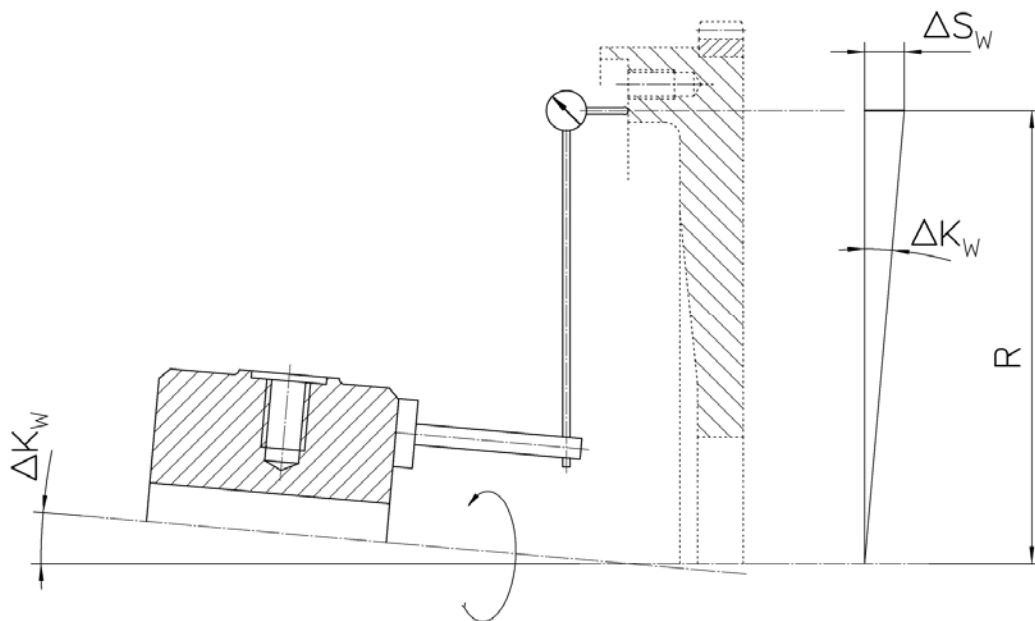

Fig. 5-3 Angular misalignment





<b>Size</b>	<b>R [mm]</b>	<b>S<sub>w</sub> max [mm]</b>
176/276	340	1.19
177/277	365	1.27
179/279	395	1.38
181/281	425	1.48
183/283	460	1.61
184/284	495	1.73

*Table 5-2 Permissible angular alignment tolerance*

## 6 Mounting

### 6.1 General assembly instructions

Any work method which impairs the safety of the coupling is prohibited.  
The user undertakes to notify the manufacturer immediately of any changes occurring at the coupling which could impair safety (address see chapter 1).

#### WARNING

**Injuries can occur as a result of:**

- Contact with rotating parts

Before starting work at the coupling, switch off the plant and secure against unintentional start-up.

#### WARNING

**Injury and material damage can occur as a result of:**

- Assembly of the coupling in the wrong sequence

Only ever assemble the coupling in the described sequence.

#### WARNING

**Injury and material damage can occur as a result of:**

- Falling coupling components

Secure coupling components against falling to the floor.

#### CAUTION

**Material damage to coupling components can occur as a result of:**

- Contact with sharp-edged objects

Protect coupling components for transportation.

Only hoist coupling components with nylon belts or ropes.

Always cushion parts when supporting them from below.

#### CAUTION

**Material damage can occur as a result of:**

- Soiled joint surfaces

The surfaces that are to be joined must be free of dirt, preservatives and lubricants.

**CAUTION**

**Material damage to coupling components can occur as a result of:**

- Anaerobic adhesives (e.g. Loctite) used for screw locking

This type of screw locking medium may not be in contact with rubber parts.





**IMPORTANT**

- Screw preparation and tightening torque levels in accordance with CENTA data sheet D13-013 (see chapter 11.1).
- Use suitable lifting devices for assembly.
- The following assembly stages are described for coupling CX-181-LFS2.
- Part illustration and marking may differ slightly from installation drawing and delivery state.

## 6.2 Mounting the hub

- Mount the hub as appropriate for the type supplied (see installation drawing).
  - Mounting the hub with feather key, see chapter 6.2.1 .
  - Mounting the hub with oil interference fit, see chapter 6.2.2 .

### 6.2.1 Mounting the hub with feather key

 <b>IMPORTANT</b>	
<p>For easier mounting of hubs and flange hubs, first heat them to a temperature of 170° - 200°C.</p>	
<b>CAUTION</b>	
	<p><b>Material damage can occur as a result of:</b></p> <ul style="list-style-type: none"> <li>▪ Incorrect heating of the hubs/flange hubs</li> </ul> <p>Heat the hubs/flange hubs steadily in an oil bath, a fan oven, on an electric hot plate, either inductive or with a flame (ring burner).</p>
<b>CAUTION</b>	
	<p><b>Injuries can occur as a result of:</b></p> <ul style="list-style-type: none"> <li>▪ Hot coupling components</li> </ul> <p>Use suitable protective gloves.</p>
<b>CAUTION</b>	
	<p><b>Material damage can occur as a result of:</b></p> <ul style="list-style-type: none"> <li>▪ Hot hubs/flange hubs</li> </ul> <p>Before further mounting of hubs/flange hubs, allow them to cool to ambient temperature.</p>

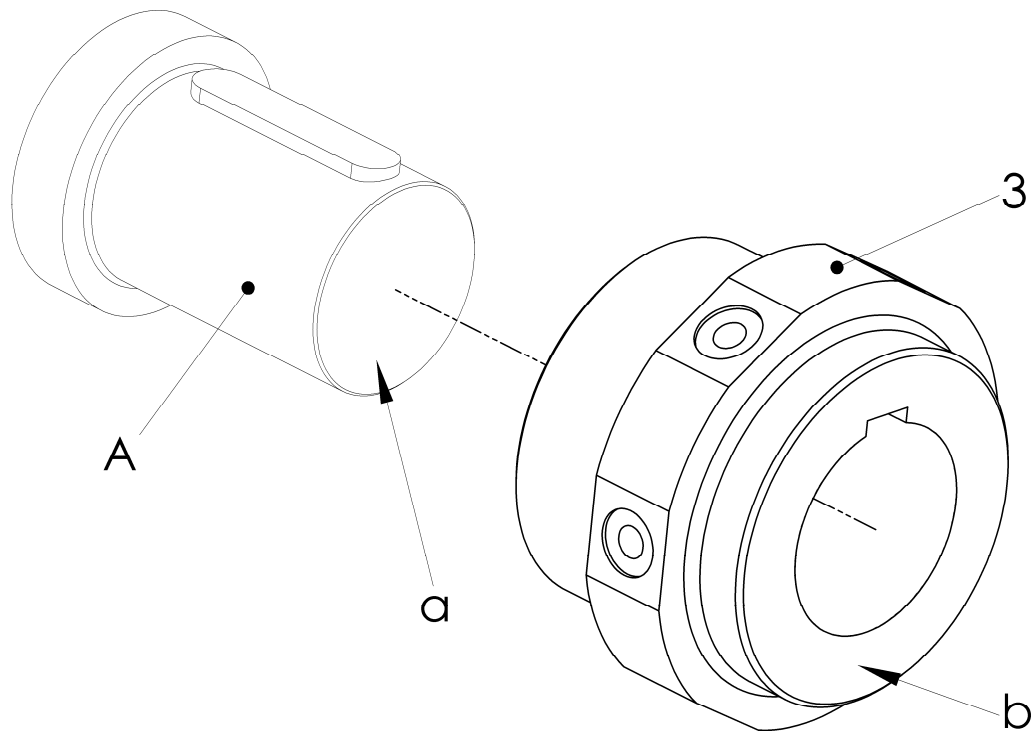

*Fig. 6-1 Mounting the hub with feather key*

Item	Info	Designation	Remark
3		Hub	
A		Shaft	Customer part
	a	Face of shaft	
	b	Face of hub	

- Push the hub (3) onto the shaft (A).



### IMPORTANT

Face of shaft must not protrude to face of hub. Otherwise radial replacement of other coupling parts is not guaranteed.

**6.2.2 Mounting the hub with oil interference fit****WARNING****Injury and material damage can occur as a result of:**

- Non-compliance with the operating instructions for the hydraulic pumps

Before carrying out work with the hydraulic pumps, do not fail to read their operating instructions. Only ever work with hydraulic pumps as described in their operating instructions.

**WARNING****Injury and material damage can occur as a result of:**

- Hydraulic fluid spraying out
- Use protective goggles.

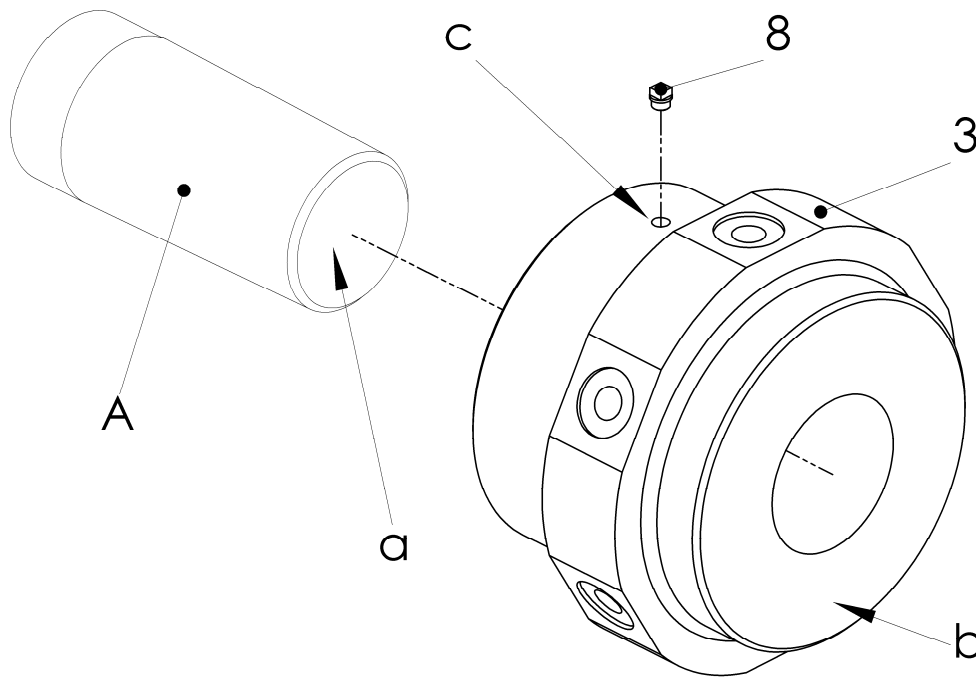

*Fig. 6-2 Mounting the hub with oil interference fit*

Item	Info	Designation	Remark
3		Hub	
8		Screw plug G¼	
A		Shaft	Customer part
	a	Face of shaft	
	b	Face of hub	
	c	Thread G¼	

**IMPORTANT**

We recommend the following mounting fluids:

- For mounting:  
Oil with a viscosity 300 mm<sup>2</sup>/s at 20°C, e.g. SKF LHM300
- For dismantling:  
Oil with a viscosity 900 mm<sup>2</sup>/s at 20°C, e.g. SKF LHDF900

- Lightly oil the cone of the shaft (A).
- Push the hub (3) onto the shaft (A).
- Remove the screw plug (8) from the hub (3).
- Connect the pump for expanding the hub (3) to the thread G¼ (c).
- Screw the pump for pushing on the hub to the shaft.
- Build up the oil pressure to push on the hub.

**WARNING**

**Material damage can occur as a result of:**

- Too fast increase of the expanding pressure in the hub
- The increase of the expanding pressure may not exceed **35 bar/minute**.

**WARNING**

**Material damage can occur as a result of:**

- Insufficient expanding pressure in the hub
- If the expanding pressure is too low, the necessary pushing pressure is too high.

- Slowly build up the oil pressure for expanding the hub.
- Build up the oil pressure alternately until the lift path (p up) of the hub (3) is reached (for p up refer to the installation drawing).
- Decrease the oil pressure for expanding the hub.
- Remove the pump for expanding the hub from the hub (3).
- Maintain the oil pressure for pushing on the hub for one hour.
- Decrease the oil pressure for pushing on the hub.
- Remove the pump for pushing on the hub from the shaft.
- Turn the hub (3), allow the oil to run out of the thread G $\frac{1}{4}$  (c) and dispose of it correctly.
- Screw the screw plug (8) into the hub (3).

 <b>IMPORTANT</b>
--

Do not place a load on the hub for 24 hours.
--

 <b>IMPORTANT</b>
--

Face of shaft must not protrude to face of hub. Otherwise radial replacement of other coupling parts is not guaranteed.
---

### 6.3 Aligning the units

- Align the units to be connected (see chapter 5).



#### 6.4 Positioning the flange onto the hub

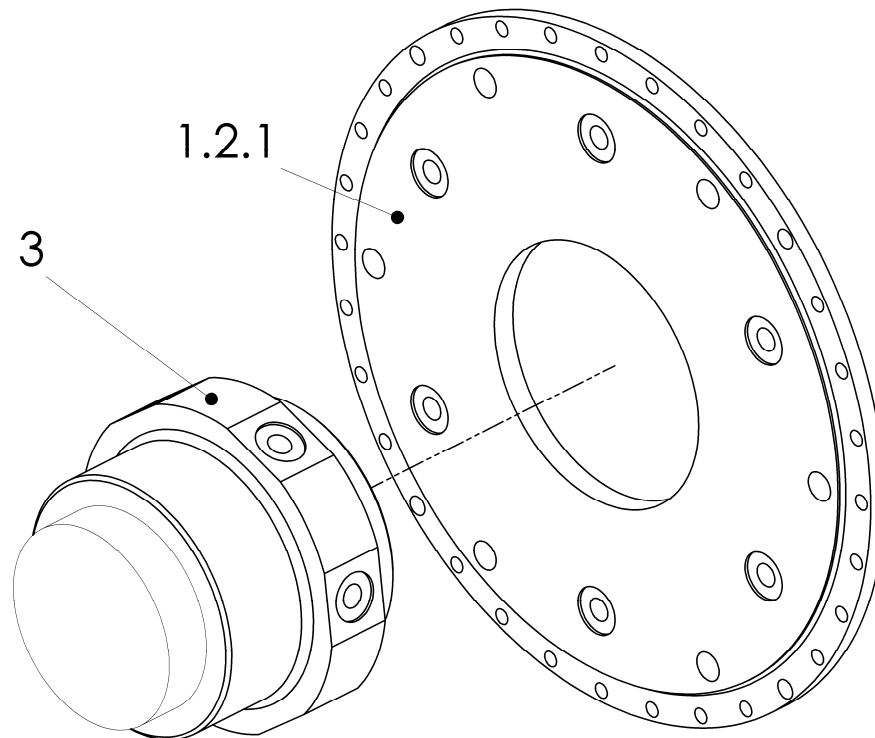
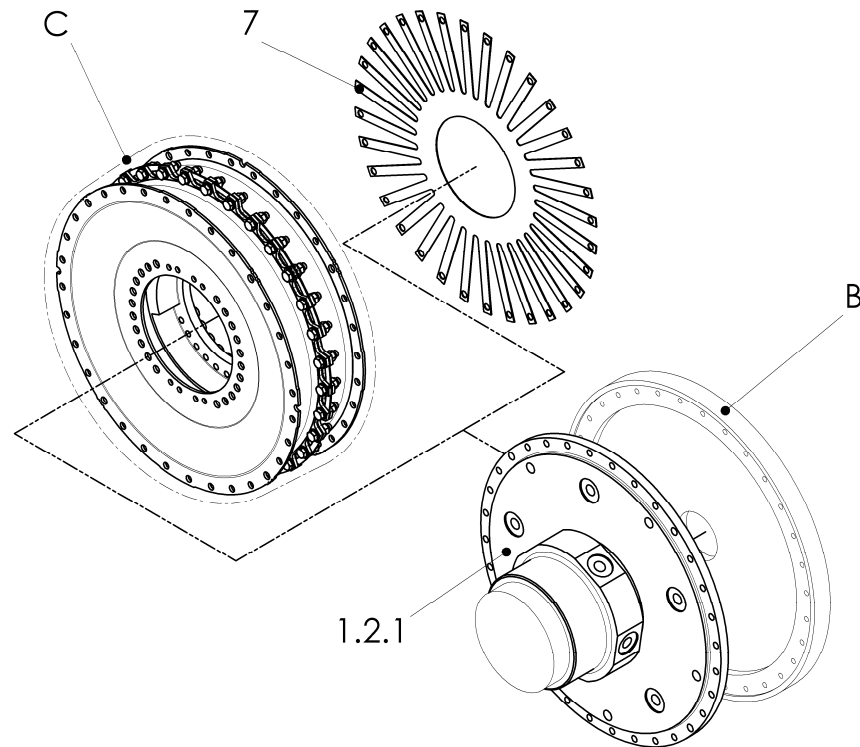

*Fig. 6-3 Positioning the flange onto the hub*

Item	Info	Designation	Remark
1.2.1		Flange	
3		Hub	

- Position the flange (1.2.1) onto the hub (3).

## 6.5 Positioning the rubber element assembly and the ventilation plate



*Fig. 6-4 Positioning the rubber element assembly and the ventilation plate*

Item	Info	Designation	Remark
1.2.1		Flange	
7		Ventilation plate	
B		Flywheel	Customer part
C		Rubber element assembly	Pre-mounted by CENTA

- Position the rubber element assembly (C) between the flange (1.2.1) and the flywheel (B) in the installation space and support.
- Push the ventilation plate (7) into the centring of the flywheel (B).

## 6.6 Mounting the rubber element assembly to the flywheel

### **IMPORTANT**

Tightening torques for elements to connect couplings with customer parts could deviate from CENTA data sheet D13-013.  
Consider datas on installation drawing.

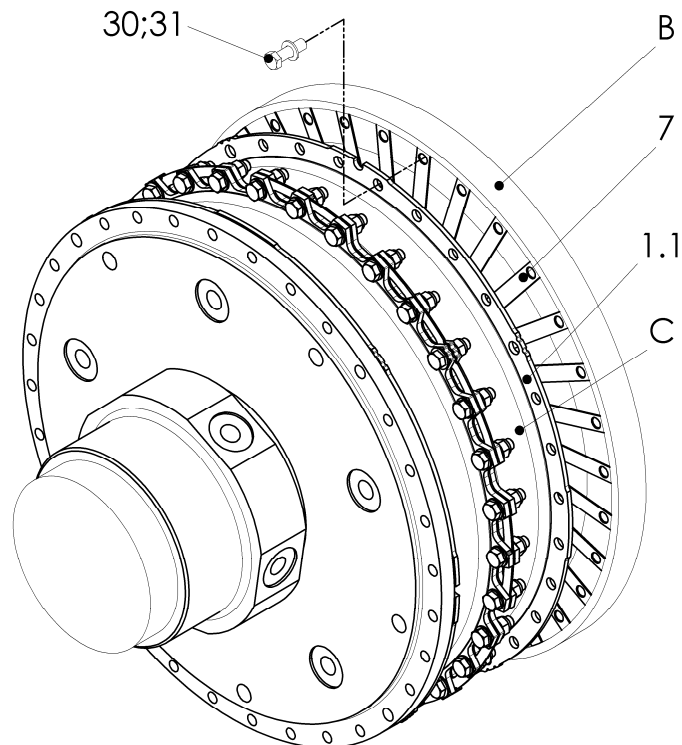

*Fig. 6-5 Mounting the rubber element assembly to the flywheel*

Item	Info	Designation	Remark
1.1		Rubber element	
7		Ventilation plate	
30		Screw	If ordered
31		Washer	If ordered
B		Flywheel	Customer part
C		Rubber element assembly	Pre-mounted by CENTA

- Push the rubber element assembly (C) into the centring of the flywheel (B).
- Screw the rubber element (1.1) of the rubber element assembly (C) and the ventilation plate (7) to the flywheel (B) using the screws (30) and the washers (31).

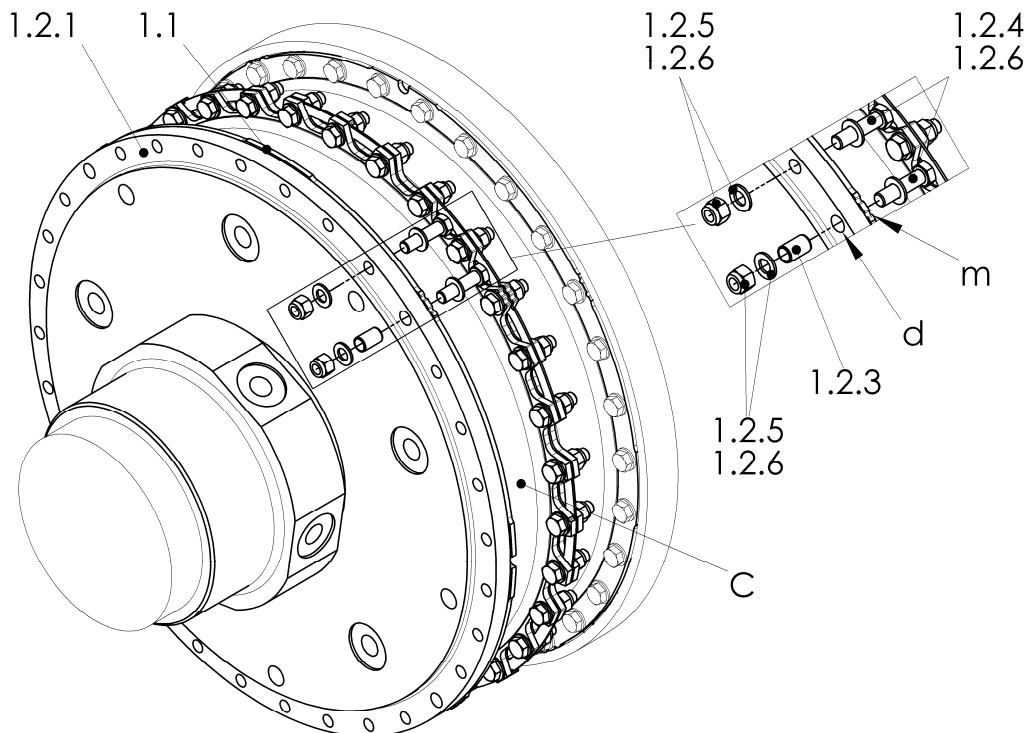
**6.7 Mounting the rubber element assembly to the flange**

*Fig. 6-6 Mounting the rubber element assembly to the flange*

Item	Info	Designation	Remark
1.1		Rubber element	
1.2.1		Flange	
1.2.3		Centring sleeve	4x90°
1.2.4		Screw ISO4762-10.9	
1.2.5		Nut ISO7040-10	
1.2.6		Washer ISO7089-300HV	
C		Rubber element assembly	
	d	Drilling (position of the centring sleeve)	
	m	Marking (position of the centring sleeve)	4x90°

 **IMPORTANT**

Ensure during installation that the centring sleeves are in the right position.  
Consider following table.

<b>Size</b>	<b>Drilling diameter [mm]</b>	<b>Centring diameter H7 [mm]</b>
176	16	20
177	18	22
179	20	24
181	19	22
183	22	26
184	24	28
186	26	30

- Turn the flange (1.2.1) towards the rubber element assembly (C) until the drillings (d) for the centring sleeves (1.2.3) and the markings (m) are aligned.  
(see table above).
- Press the centring sleeves (1.2.3; 4x90°) through the drillings (d) of the flange (1.2.1) into the drillings of the rubber element (1.1) of the rubber element assembly (C).
- Screw the rubber element assembly (C), and the centring sleeves (1.2.3) (4x90°) to the flange (1.2.1) using the screws (1.2.4), the washers (1.2.6) and the nuts (1.2.5).
- Screw the rubber element assembly (C) to the flange (1.2.1) using the screws (1.2.4), the washers (1.2.6) and the nuts (1.2.5).

### 6.8 Mounting size 3 and 4 links ("ccw" / "cw" rotation)

 **IMPORTANT**

- The links must be mounted in such a way that they are subjected to tensile load. A differentiation is made between the direction of rotation left (**ccw**) and right (**cw**), looking towards the driving end.
- Links are packaged in sets.
- All links of a link set are the same weight.
- Only mount links in complete sets "crosswise".
- Instructions on how to mount **one** link are provided following. Item numbers and the part illustrations may differ slightly from the delivery state.

The following table gives an overview of the number of size of the links used.

CENTALINK Size	CENTAX Size	Size	Link Quantity
70	69/70/71	3	4
72	72		5
75	75 176/276		6
76	-		7
77	-		8
78	78 177/277	4	4
80/81	80/81 179/181/279/281		5
82/84/85	82/84/85 183/184/283/284		6
88	88		8
90	90		9

*Table 6-1 Guide to links Size 3 and 4*

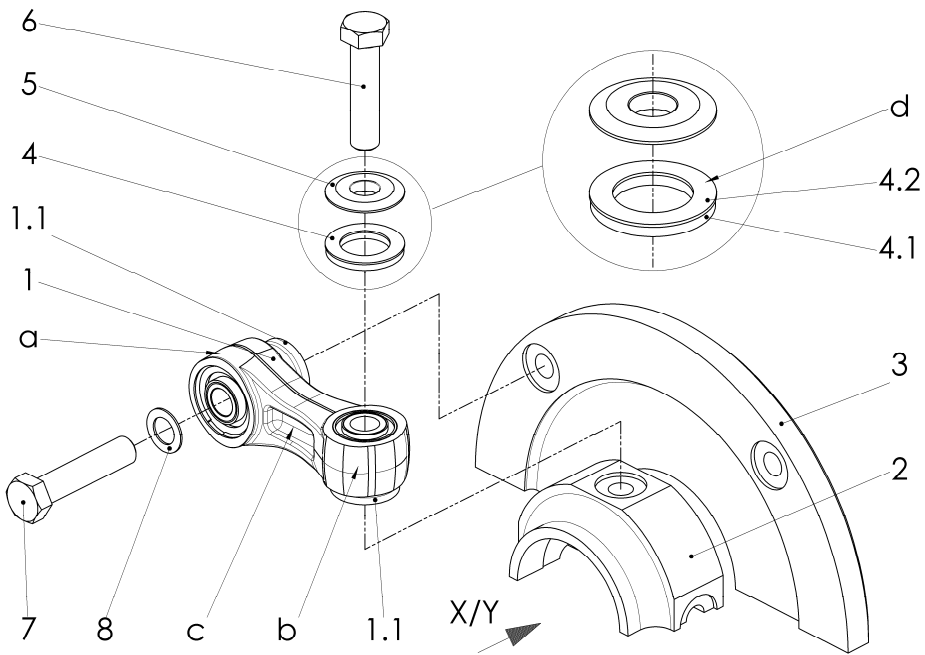

*Fig. 6-7 Mounting size 3 and 4 links ("ccw" counterclockwise rotation)*

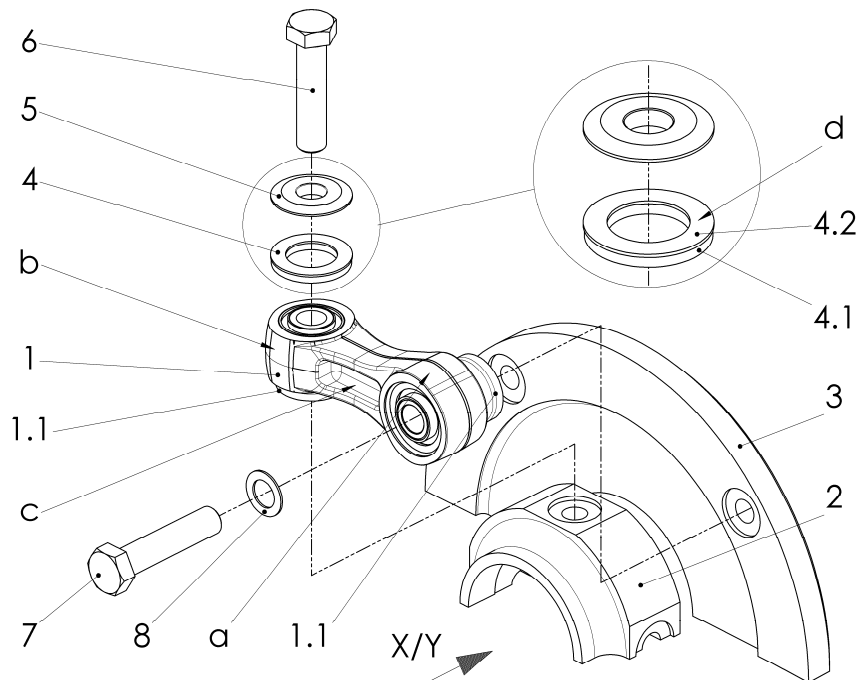

*Fig. 6-8 Mounting size 3 and 4 links ("cw" clockwise rotation)*



Item	Info	Designation	Remark
	X/Y	Looking	at the flange
1		Link unit	
	a	Label "Flange"	
	b	Label "Hub"	
	c	The recess must be pointing towards the flange	
1.1		Collar sleeve	
2		Hub/tube	
3		Flange	
4		Bearing unit comprising:	
4.1		PU bearing	
4.2		Sliding bearing	
	d	PTFE coating must be at the top	
5		Washer for centrifugal bearing	
6		Screw ISO4014-10.9	Dimensions as shown in parts list
7		Screw ISO4014-10.9	Dimensions as shown in parts list
8		Washer	

- Set the link unit (1) marked "Flange" on the centring fixture of the flange (3).
- Position the link side with the inscription "Hub" against the centring fixture of the hub/tube (2).
- Tighten the screw (7; "Flange") with the washer (8) and the screw (6; "Hub"), washer for centrifugal bearing (5) and the bearing unit (4; PTFE coating must be at the top) alternately by hand until the centring fixtures of the collar sleeves (1.1) are seated in the centring fixtures of the hub/tube (2) / flange (3).
- Repeat the mounting section above until all links are mounted (for quantity of the links, please see the table guide to links).
- Fasten the screws (6 and 7) of the link unit (1) by required tightening torque "crosswise".



**6.9 After completed mounting****WARNING****Injury and material damage can occur as a result of:**

- Loose screw connections

Before commissioning, the tightening torque levels of all screws must be checked and corrected if necessary.

Before commencing long-term operation, the plant must successfully complete a test run.

## 7 Operation

### WARNING



**Injury and material damage can occur as a result of:**

- Worn coupling components

If the running noises change and/or vibrations occur turn the plant off immediately.

Determine the fault and its root cause, and remedy.  
The troubleshooting process is simplified by the table in the next chapter.  
On principle in case of a fault, an analysis of the entire plant should be performed.

### 7.1 Operating faults, root causes and remedy

Faults	Possible root causes	Remedy
Running noises or vibrations in the plant	Alignment error	<ol style="list-style-type: none"> <li>1. Switch off the plant</li> <li>2. Check alignment, correct if applicable</li> <li>3. Trial run</li> </ol>
	Loose bolts	<ol style="list-style-type: none"> <li>1. Switch off the plant</li> <li>2. Check alignment, correct if applicable</li> <li>3. Check screw torque levels and correct if necessary</li> <li>4. Trial run</li> </ol>
	Defective rubber bushes of the links	<ol style="list-style-type: none"> <li>1. Switch off the plant</li> <li>2. Replace the links</li> <li>3. Check alignment, correct if applicable</li> <li>4. Trial run</li> </ol>
Breakage of the rubber element/ rubber segment	Alignment error or inadmissibly high torque	<ol style="list-style-type: none"> <li>1. Switch off the plant</li> <li>2. Exchange defective parts</li> <li>3. Check alignment, correct if applicable</li> <li>4. Trial run</li> </ol>

*Table 7-1 Troubleshooting table*

In case of uncertainty or if you have questions, please contact our head office (address see chapter 1).



## **7.2 Admissible overall misalignment of the coupling**

The overall misalignment values can be found in the catalogue.

## 8 Care and maintenance

### WARNING

**Injuries can occur as a result of:**

- Contact with rotating parts

Before starting work at the coupling, switch off the plant and secure against unintentional start-up.

The coupling requires low maintenance. We recommend a visual inspection at the regular scheduled maintenance intervals for the whole unit.

### 8.1 Work to be performed

#### 8.1.1 Cleaning the coupling

- Remove any loose dirt from the coupling.

#### 8.1.2 Visual inspection of the coupling

- Inspect the coupling for cracks, chips or missing parts.
- Replace faulty and missing parts.

#### 8.1.3 Visual inspection of links

- Make a visual inspection of the links every **12** months.

Pay particular attention to the rubber bushes of the links. Squash folds and small cracks of up to 1 mm may be considered normal.

In the case of crack depths in excess of 1 mm, or detachment of the rubber-to-metal bond, the links must be exchanged.

### **IMPORTANT**

Exchange the links:

- In the event of damage
- When replacing the rubber elements

### **IMPORTANT**

- Links are packaged in sets.
- All links of a link set are the same weight.
- Only mount or replace links in complete sets.

---

**8.1.4 Visual inspection of the rubber elements / rubber segments****IMPORTANT**

Exchange the rubber elements / rubber segments in the event that:

- The wear specifications given in W00-002 are exceeded

- Assess the rubber elements / rubber segments as described in CENTA guidelines W00-002.

**8.1.5 Inspection of the screw connections**

- Check the tightening torque levels of all screws and if necessary, correct.







**8.2 Replacing defective parts**

- Remove the coupling as described in chapter 9.
- Replace wearing parts.
- Mount the coupling as described in chapter 6.

## 9 Dismantling

### 9.1 General dismantling instructions

Any work method which impairs the safety of the coupling is prohibited.  
The user undertakes to notify the manufacturer immediately of any changes occurring at the coupling which could impair safety (address see chapter 1).

 <b>IMPORTANT</b>	
The coupling is dismantled in reverse order to the assembly process. Please refer to the illustrations in chapter 6.	
<b>WARNING</b>	
	<p><b>Injuries can occur as a result of:</b></p> <ul style="list-style-type: none"> <li>▪ Contact with rotating parts</li> </ul> <p>Before starting work at the coupling, switch off the plant and secure against unintentional start-up.</p>
<b>WARNING</b>	
	<p><b>Injury and material damage can occur as a result of:</b></p> <ul style="list-style-type: none"> <li>▪ Dismantling of the coupling in the wrong sequence</li> </ul> <p>Only ever dismantle the coupling in the described sequence.</p>
<b>WARNING</b>	
	<p><b>Injury and material damage can occur as a result of:</b></p> <ul style="list-style-type: none"> <li>▪ Falling coupling components</li> </ul> <p>Secure coupling components against falling to the floor.</p>
<b>CAUTION</b>	
	<p><b>Material damage to coupling components can occur as a result of:</b></p> <ul style="list-style-type: none"> <li>▪ Contact with sharp-edged objects</li> </ul> <p>Protect coupling components for transportation. Only hoist coupling components with nylon belts or ropes. Always cushion parts when supporting them from below.</p>
 <b>IMPORTANT</b>	
Use suitable lifting devices for dismantling.	

## **9.2 Dismantling the links**

### **See Fig. 6-7 and 6-8:**

- Loosen the screws (6 and 7) of the links (1) alternately ("Flange"/"Hub") and remove with the bearing unit (4) and the washers (5 and 8).
- Remove the links (1).

## **9.3 Dismantling the rubber element assembly from the flange**

### **See Fig. 6-6:**

- Loosen the screws (1.2.4) of the connection rubber element assembly (C) and flange (1.2.1) and remove with the washers (1.2.6) and the nuts (1.2.5).
- Pull the flange (1.2.1) away from the rubber element assembly (C) and place it on the hub.
- Press the centring sleeves (1.2.3; 4x90°) out of the drillings (d) of the flange (1.2.1) and remove.

## **9.4 Dismantling the rubber element assembly and the ventilation plate from the flywheel**

### **See Fig. 6-5 and 6-4:**

- Support the rubber element assembly (C).
- Loosen the screws (30) of the connection rubber element assembly (C), ventilation plate (7) and flywheel (B) and remove with the washers (31; if present).
- Pull the rubber element assembly (C) off the centring of the flywheel (B).
- Pull the ventilation plate (7) off the centring of the flywheel (B) and remove.
- Remove the rubber element assembly (C) out of the installation space.

### **9.4.1 Removing the mounting supports**

- Remove all mounting supports.

## **9.5 Dismantling the flange**

### **See Fig. 6-3:**

- Remove the flange (1.2.1) out of the installation space.

## **9.6 Dismantling the hub**





### **If necessary (see Fig. 6-1 and 6-2):**

- Dismantle the hub as appropriate for the type supplied.
  - Dismantling the hub with feather key, see chapter 9.6.1 .
  - Dismantling the hub with oil interference fit, see chapter 9.6.2 .

**9.6.1 Dismantling the hub with feather key**
**See Fig. 6-1:**

- Remove the hub (3) from the shaft (A).

**9.6.2 Dismantling the hub with oil interference fit**
**See Fig. 6-2:**

<b>WARNING</b>	
	<p><b>Injury and material damage can occur as a result of:</b></p> <ul style="list-style-type: none"> <li>▪ Non-compliance with the operating instructions for the hydraulic pumps</li> </ul> <p>Before carrying out work with the hydraulic pumps, do not fail to read their operating instructions. Only ever work with hydraulic pumps as described in their operating instructions.</p>
<b>WARNING</b>	
	<p><b>Injury and material damage can occur as a result of:</b></p> <ul style="list-style-type: none"> <li>▪ Hydraulic fluid spraying out</li> </ul> <p>Use protective goggles.</p>
<b>WARNING</b>	
	<p><b>Injuries and material damages can occur by:</b></p> <ul style="list-style-type: none"> <li>▪ Suddenly loosening hubs</li> </ul> <p>Secure the hub with a hydraulic tool against sudden axial loosening.</p>
 <b>IMPORTANT</b>	
<p>We recommend the following mounting fluids:</p> <ul style="list-style-type: none"> <li>• For mounting: Oil with a viscosity 300 mm<sup>2</sup>/s at 20°C, e.g. SKF LHMF300</li> <li>• For dismantling: Oil with a viscosity 900 mm<sup>2</sup>/s at 20°C, e.g. SKF LHDF900</li> </ul>	

- Remove the screw plug (8) from the hub (3).
- Connect the pump for expanding the hub to the thread (c) of the hub (3).
- Screw the pump for holding the hub to the shaft (A).
- Build up the oil pressure in order to hold the hub.



**WARNING****Material damage can occur as a result of:**

- Too fast increase of the expanding pressure in the hub
- The increase of the expanding pressure may not exceed **35 bar/minute**.

- Slowly build up the oil pressure to expand the hub ( **$p_{\max} = 1500 \text{ bar}$** ).
- Slowly reduce the oil pressure for holding the hub.
- Slowly reduce the oil pressure for expanding the hub.
- Repeat the above mounting section, until the hub (3) is completely released from the shaft (A).
- Remove the pump for holding the hub from the shaft (A).
- Remove the pump for expanding the hub from the hub (3).
- Turn the hub (3), allow the oil to run out of the thread G $\frac{1}{4}$  (c) and dispose of it correctly.
- Screw the screw plug (8) into the hub (3).

**9.7 Reassembling the coupling**

- Reassemble the coupling as described in chapter 6.

**10 Wearing and spare parts****WARNING****Injury and material damage can occur as a result of:**

- Mounting and/or utilization of non-original CENTA parts
- Never use parts from other manufacturers.

A stock of the most important wearing and spare parts is the most important condition to ensure that the coupling is functional and ready for operation at all times.

We only provide a warranty for CENTA original parts.

Wearing parts of this coupling:

- The link kits (BS). These contain all screws, washers and bearing units. In the event that links or rubber bushes of the link are faulty, they must be replaced as a complete set.
- The rubber elements. These are delivered pre-assembled as BG rubber elements. When exchanging the rubber elements, all screw connections must be renewed. These must be ordered separately.

**IMPORTANT**

- Links are packaged in sets.
- All links of a link set are the same weight.
- Only mount or replace links in complete sets.

When ordering a spare, specify:

- Order no.
- Coupling order no.
- Drawing no.



## 11 Annex

### 11.1 CENTA data sheet D13-013 (lubricated screw connections)

**Validity:**

For all non-dynamically stressed screw connections with **lubricated** shank bolts in accordance with ISO 4014, ISO 4017 and ISO 4762 (DIN 912) with metric standard thread in accordance with DIN ISO 262, unless other specifications are given on CENTA documents.

**Preparation of parts that are to be screwed together:**

The joining areas must be free of dirt, preservatives and lubricants.

**Preparation of screws that ARE NOT secured with liquid screw locking medium:**

Give the screws extra lubrication with motor oil under the screw head and in the thread.

**Preparation of screws that ARE secured with liquid screw locking medium:**

Give the screws extra lubrication with motor oil under the screw head. Remove all grease from the thread.

**Screw tightening method:**

Screw in (by hand with torque wrench).

d	Thread size			d	Thread size		
	Strength class	Tightening torques			Strength class	Tightening torques	
		[Nm] ±5%	[in lbs] ±5%			[Nm] ±5%	[in lbs] ±5%
<b>M6</b>	8.8	9	80	<b>M22</b>	8.8	470	4160
	10.9	13	115		10.9	670	5930
	12.9	15	135		12.9	780	6900
<b>M8</b>	8.8	21	185	<b>M24</b>	8.8	600	5310
	10.9	30	265		10.9	850	7520
	12.9	35	310		12.9	1000	8850
<b>M10</b>	8.8	41	360	<b>M27</b>	8.8	750	6640
	10.9	60	530		10.9	1070	9470
	12.9	71	630		12.9	1250	11060
<b>M12</b>	8.8	71	630	<b>M30</b>	8.8	1000	8850
	10.9	104	920		10.9	1450	12830
	12.9	121	1070		12.9	1700	15050
<b>M14</b>	8.8	113	1000	<b>M33</b>	8.8	1400	12400
	10.9	165	1460		10.9	1950	17250
	12.9	195	1725		12.9	2300	20350
<b>M16</b>	8.8	170	1500	<b>M36</b>	8.8	1750	15500
	10.9	250	2210		10.9	2500	22150
	12.9	300	2660		12.9	3000	26550
<b>M18</b>	8.8	245	2170	<b>M39</b>	8.8	2300	20350
	10.9	350	3100		10.9	3300	29200
	12.9	410	3630		12.9	3800	33650
<b>M20</b>	8.8	350	3100				
	10.9	490	4340				
	12.9	580	5130				