

+ + +

+ + +

+ + +

+ + +

+ + +

+ + +

+ + +

+ + +

+ + +

+ + +

+ + +

# CENTAFLEX-H

Assembly and operating instructions

008H-00400-1000/3000

M008-00084-EN

Rev. 1

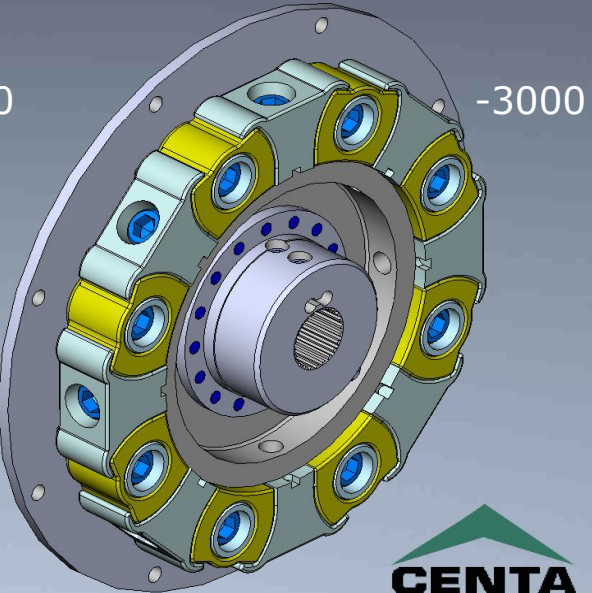
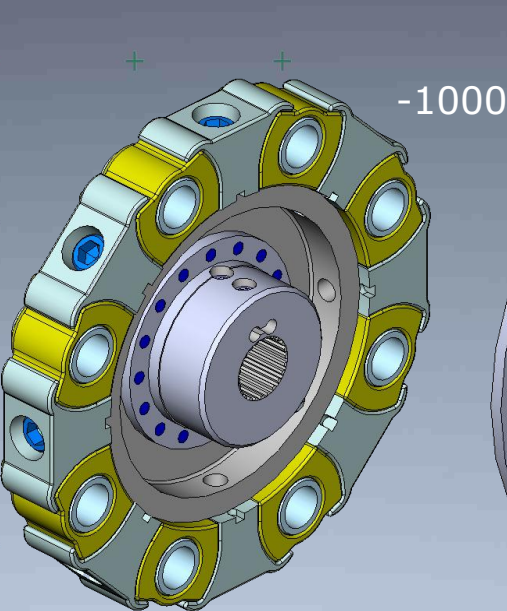
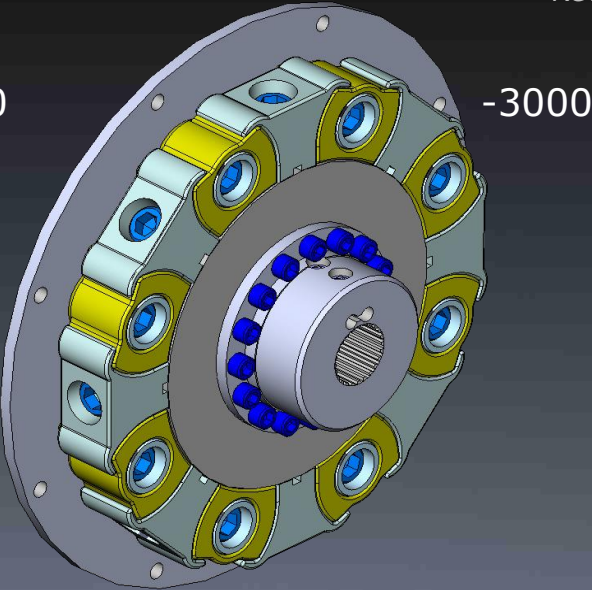
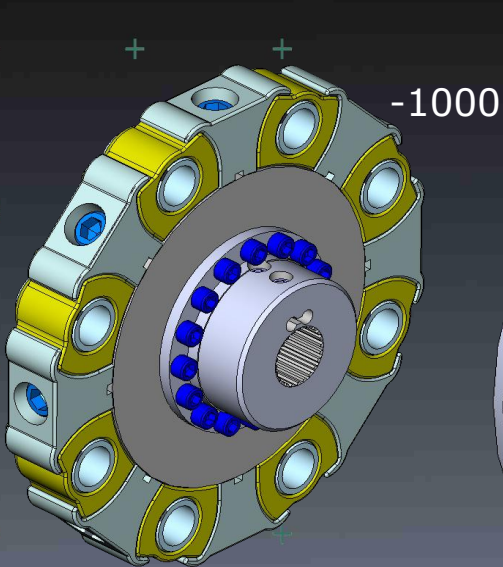

Power Transmission  
Leading by innovation



## Contents

<b>1</b>	<b>General remarks .....</b>	<b>5</b>
<b>2</b>	<b>Safety .....</b>	<b>6</b>
2.1	Safety remarks .....	6
2.1.1	Signal words .....	6
2.1.2	Pictograms .....	7
2.2	Qualification of deployed personnel .....	7
2.3	Intended application.....	7
2.4	Application not in compliance with the intended use .....	9
<b>3</b>	<b>Delivery, transport, storage and disposal .....</b>	<b>10</b>
3.1	Delivery .....	10
3.2	Transport.....	10
3.3	Storage .....	10
3.3.1	Storage location.....	11
3.3.2	Storage of couplings / flexible elements .....	11
3.4	Disposal.....	11
<b>4</b>	<b>Technical description .....</b>	<b>12</b>
4.1	Characteristics.....	12
4.2	Specifications .....	12
<b>5</b>	<b>Mounting .....</b>	<b>13</b>
5.1	General assembly instructions .....	13
5.2	Mounting overview .....	15
5.3	Mounting the adapter (9; design -3000) .....	17
5.4	Preparing the pre-mounted assembly (C) for initial assembly .....	18
5.5	Mounting the bushes (3) .....	19
5.6	Mounting the hub (2) .....	20
5.6.1	Mounting the hub (2) with cylindrical bore and keyway .....	20
5.6.2	Mounting the hub (2) with CENTALOC clamping .....	22
5.7	Mounting the pre-mounted assembly (C) .....	24
5.8	Connecting the driving and the driven units .....	26
5.9	After completed mounting.....	27
<b>6</b>	<b>Operation.....</b>	<b>28</b>
6.1	Operating faults, root causes and remedy .....	28



<b>7</b>	<b>Care and maintenance .....</b>	<b>29</b>
7.1	Work to be performed .....	29
7.1.1	Cleaning the coupling .....	29
7.1.2	Visual inspection of the coupling .....	29
7.1.3	Visual inspection of the elastic element/-s.....	29
7.1.4	Inspection of the screw connections .....	29
7.2	Replacing defective parts .....	29
<b>8</b>	<b>Dismantling .....</b>	<b>30</b>
8.1	General dismantling instructions .....	30
8.2	Separating the driving and the driven units.....	31
8.3	Dismantling the elastic elements.....	31
8.4	Dismantling the pre-mounted assembly (C) from the hub (2).....	32
8.5	Dismantling the hub (2; if necessary).....	32
8.5.1	Dismantling the hub (2) with cylindrical bore and keyway .....	32
8.5.2	Dismantling the hub (2) with CENTALOC clamping .....	32
8.6	Dismantling the bushes (3; if necessary) .....	32
8.7	Dismantling the adapter (9; design -3000; if necessary).....	32
8.8	Reassembling the coupling.....	32
<b>9</b>	<b>Annex .....</b>	<b>33</b>
9.1	CENTA data sheet D013-016 (unlubricated screw connections) .....	33
9.2	CENTA data sheet D13-019 (IP-screw connections).....	34
9.3	CENTA data sheet D008-902 Declaration of incorporation according to the EC Machinery Directive 2006/42/EC, Appendix II B.....	35



**Index of illustrations**

Fig. 5-1 Detail of the installation drawing title block .....15

Fig. 5-2 Mounting the adapter (9; design -3000) .....17

Fig. 5-3 Preparing the pre-mounted assembly (C) for initial assembly .....18

Fig. 5-4 Mounting the bushes (3) .....19

Fig. 5-5 Mounting the hub (2) with cylindrical bore and keyway .....20

Fig. 5-6 Mounting the hub (2) with CENTALOC clamping .....22

Fig. 5-7 Mounting the pre-mounted assembly (C) with drillings (v) to the hub (2)...24

Fig. 5-8 Mounting the hub (2) to the pre-mounted assembly (C) with threads (s) ...24

Fig. 5-9 Connecting the driving and the driven units .....26

Fig. 8-1 Dismantling the elastic elements.....31

**Index of tables**

Table 2-1 Shape and size of ventilation holes ..... 8

Table 5-1 Scope of supply of the design and chapters of mounting.....16

Table 5-2 Tightening torques for threaded pins.....21

Table 6-1 Troubleshooting table .....28



## **1 General remarks**

These assembly and operating instructions form a constituent part of the coupling delivery and must be kept in an easily accessible place at all times.

CENTA products are developed and produced to quality standard DIN EN ISO 9001:2000.

In the interests of further development, CENTA reserves the right to make technical changes.



### **IMPORTANT**

CENTA is unable to accept liability for damage and operating faults caused by failure to observe the operating instructions.

These operating instructions are protected under copyright to CENTA Antriebe Kirschey GmbH.

In case of technical questions, please enquire with our head office:

**CENTA Antriebe  
Kirschey GmbH**  
Bergische Strasse 7  
42781 Haan  
GERMANY  
Phone +49-2129-912-0  
Fax +49-2129-2790  
centa@centa.de  
www.centa.info

## 2 Safety

The purpose of these operating instructions is to enable users to:

- use the coupling safely and correctly
- maximize efficiency
- ensure that care and maintenance are carried out correctly

For this reason, these operating instructions must be thoroughly read and understood prior to work on and with the coupling.

### WARNING



#### **Injury and material damage can occur as a result of:**

- Failure to adhere to the safety and accident prevention regulations valid at the relevant installation site

The safety and accident prevention regulations valid at the installation site in question must be adhered to when performing any of the tasks described in these operating instructions.

### 2.1 Safety remarks

In these operating instructions, safety remarks are indicated by a pictogram and a signal word.

#### 2.1.1 Signal words

The following signal words are used in the safety remarks:

**DANGER**

Denotes the immediate threat of danger.  
If not prevented, fatal or extremely serious injuries can result.

**WARNING**

Denotes a potentially dangerous situation.  
If not prevented, fatal or extremely serious injuries can result.

**CAUTION**

Denotes a potentially dangerous situation.  
If not prevented, minor injuries and/damage to property may result.

**IMPORTANT**

Denotes application tips and particularly useful information. This is not a signal word denoting a dangerous or damaging situation.

### 2.1.2 Pictograms

Possible pictograms in the safety precautions:



Warning of a hazardous area



Do not switch



Use protective gloves



Use protective goggles

### 2.2 Qualification of deployed personnel

All the work described in these operating instructions may only be performed by authorized persons with adequate training and instruction.

<b>WARNING</b>	
	<p><b>Injury and material damage can occur as a result of:</b></p> <ul style="list-style-type: none"> <li>▪ Work at the coupling which is not described in these instructions</li> </ul> <p>Only carry out work which is described in these operating instructions.</p>

### 2.3 Intended application

<b>WARNING</b>	
	<p><b>Injury and material damage can occur as a result of:</b></p> <ul style="list-style-type: none"> <li>▪ Application not in compliance with the intended use</li> </ul> <p>The couplings are intended exclusively for use in accordance with the relevant design. They may only be used under the specified conditions.</p>

**WARNING**



**Injuries can occur as a result of:**

- Contact with rotating parts

Shield the coupling in accordance with the applicable accident prevention regulations with an enclosure.

**Exception:**

The coupling is encased by the driving and driven units.

**The scope of delivery provided by CENTA does not include a protective enclosure.**

This enclosure must fulfil the following criteria:

- Provide protection against persons gaining access to rotating parts
- Restrain any rotating parts which may be work loose
- Guarantee sufficient ventilation for the coupling

This enclosure must be made of stable steel components. In order to ensure adequate ventilation for the coupling, the enclosure must be fitted with regular openings. For safety reasons, these openings must not exceed the dimensions outlined in table 2-1.

<b>Component</b>	<b>Circular openings [mm]</b>	<b>Rectangular openings [mm]</b>
Top of the enclosure	Ø 8	□ 8
Side elements of the enclosure	Ø 8	□ 8

*Table 2-1 Shape and size of ventilation holes*

The enclosures must be positioned a minimum of 15 mm distant from rotating parts. The enclosure must be electrically conductive and be included in the equipotential bonding.

Before commencing long-term operation, the plant must successfully complete a test run.



**2.4 Application not in compliance with the intended use****WARNING****Injury and material damage can occur as a result of:**

- Inadmissibly high torque
- Inadmissibly high or low speeds
- Exceeding the specified ambient temperature
- Inadmissible ambient medium
- Inadmissible coupling enclosure
- Exceeding the admissible overall misalignment values

Only use the coupling for the specified application.

CENTA bears no liability for damage resulting from application not in compliance with the intended use of the equipment.

Should there be a change of plant parameters, the coupling design must be reviewed by CENTA (address see chapter 1).



### 3 Delivery, transport, storage and disposal

#### 3.1 Delivery

After delivery, the coupling:

- must be checked for completeness and correctness of the delivery.
- must be examined for possible transport damage (which must be reported immediately to the carrier).



#### 3.2 Transport

<b>CAUTION</b>	
	<p><b>Injury and material damage can occur as a result of:</b></p> <ul style="list-style-type: none"><li>▪ Incorrect transportation of couplings</li></ul> <p>Ensure that the coupling is correctly transported.</p>
<b>CAUTION</b>	
	<p><b>Material damage to coupling components can occur as a result of:</b></p> <ul style="list-style-type: none"><li>▪ Contact with sharp-edged objects</li></ul> <p>Protect coupling components for transportation. Only hoist coupling components with nylon belts or ropes. Always cushion parts when supporting them from below.</p>

Following transportation damage:

- Check the coupling carefully for damage.
- Consult the manufacturer (Address see chapter 1).

#### 3.3 Storage

<b>CAUTION</b>	
	<p><b>Material damage to elastic elements and rubber parts can occur as a result of:</b></p> <ul style="list-style-type: none"><li>▪ Incorrect storage</li></ul> <p>These parts must be stored laid flat and so they cannot distort, and protected from ozone, heat, light, moisture and solvents.</p>
 <b>IMPORTANT</b>	
Rubber parts are marked where possible with their production date. From this date, they may only be stored for a maximum of 5 years.	

**3.3.1 Storage location**

Requirements imposed on the storage location:

- Moderately ventilated and low in dust
- Dry (max. 65% humidity)
- Temperature stabilized (-10°C to +25°C)
- Free of ozone-producing devices such as light sources and electric motors
- Free of UV light sources and direct sunlight
- Do not store solvents and disinfectants, fuels or lubricants, acids, chemicals etc. in the same location

For more details, refer to DIN 7716.

**3.3.2 Storage of couplings / flexible elements**

- Unpack the parts.
- Check the packaging for damage. Replace if necessary.
- Check that the wax protection on steel components is intact. If necessary, patch or renew.
- Package the parts (for prolonged periods of storage, enclose desiccant and weld into film).
- Place the parts into storage.

**3.4 Disposal**

<b>RECYCLING</b>	
	Ensure safe, environmentally responsible disposal of operating supplies and exchange parts. For this, locally provided recycling facilities and regulations must be utilized.

For disposal, the coupling parts must be separated where possible and sorted according to material type.



## **4 Technical description**

### **4.1 Characteristics**

The CENTAFLEX-H coupling series offers the following advantages:

- High performance with compact dimensions.
- High torsional stiffness, yet accommodation of minor misalignments and dampening of vibrations.
- High permissible rotational speeds.
- Extremely high thermal stability -50° to +150°C (-58° to +300°F)
- Oil resistant.
- Easy push in assembling.
- Free of axial forces.
- Free of wear hub-shaft screw clamping.
- Low maintenance.
- Noiseless.
- Cost efficient.





### **4.2 Specifications**

The specifications can be found in the catalogue and the dimensions in the installation drawing.

## 5 Mounting

### 5.1 General assembly instructions

Any work method which impairs the safety of the coupling is prohibited.  
The user undertakes to notify the manufacturer immediately of any changes occurring at the coupling which could impair safety (address see chapter 1).

<b>WARNING</b>	
	<p><b>Injuries can occur as a result of:</b></p> <ul style="list-style-type: none"> <li>▪ Contact with rotating parts</li> </ul> <p>Before starting work at the coupling, switch off the plant and secure against unintentional start-up.</p>
<b>WARNING</b>	
	<p><b>Injury and material damage can occur as a result of:</b></p> <ul style="list-style-type: none"> <li>▪ Assembly of the coupling in the wrong sequence</li> </ul> <p>Only ever assemble the coupling in the described sequence.</p>
<b>WARNING</b>	
	<p><b>Injury and material damage can occur as a result of:</b></p> <ul style="list-style-type: none"> <li>▪ Falling coupling components</li> </ul> <p>Secure coupling components against falling to the floor.</p>
<b>CAUTION</b>	
	<p><b>Material damage to coupling components can occur as a result of:</b></p> <ul style="list-style-type: none"> <li>▪ Contact with sharp-edged objects</li> </ul> <p>Protect coupling components for transportation. Only hoist coupling components with nylon belts or ropes. Always cushion parts when supporting them from below.</p>
<b>CAUTION</b>	
	<p><b>Material damage can occur as a result of:</b></p> <ul style="list-style-type: none"> <li>▪ Soiled joint surfaces</li> </ul> <p>The surfaces that are to be joined must be free of dirt, preservatives and lubricants.</p>

 **IMPORTANT**

- Screw preparation and tightening torque levels for screws item(s) 8 in accordance with CENTA data sheet D013-016 (see chapter 9.1).
- Screw preparation and tightening torque levels for screws item(s) 4 in accordance with CENTA data sheet D013-019 (see chapter 9.2)
- The tightening torques for the threaded pins of hubs/flange hubs according to table 5-2 (see chapter 5.6.1).
- Use suitable lifting devices for assembly.
- Elements for connection of the coupling to customer components do not form part of the delivery.
- The following assembly stages are described for coupling 008H-00400-....
- Part illustration and marking may differ slightly from installation drawing and delivery state.

 **IMPORTANT**

Use exclusively **new** screws supplied by CENTA. These are coated with microencapsulated adhesive INBUS PLUS **IP** which serves as a screw locking medium.

 **IMPORTANT**

To ensure optimum screw locking, after tightening the curing time for the microencapsulated adhesive must be observed:

- Appr. 4-5 hours at room temperature (20°C)
- Higher temperatures will accelerate the curing time (e.g. 15 minutes at 70°C created by a hot air blower)

After 24 hours, the adhesive is completely cured.

**CAUTION**



**Injuries can occur as a result of:**

- Hot coupling components
- Use suitable protective gloves.

**WARNING**



**Injuries and material damages can occur by:**

- Loosening adjustment screws (For fastening the hub/flange hubs)
- Lock adjustment screw with Loctite.

## 5.2 Mounting overview

Mount the coupling as appropriate for the supplied design.  
 These informations can be found in the title block of the installation drawing.  
 They are explained below.

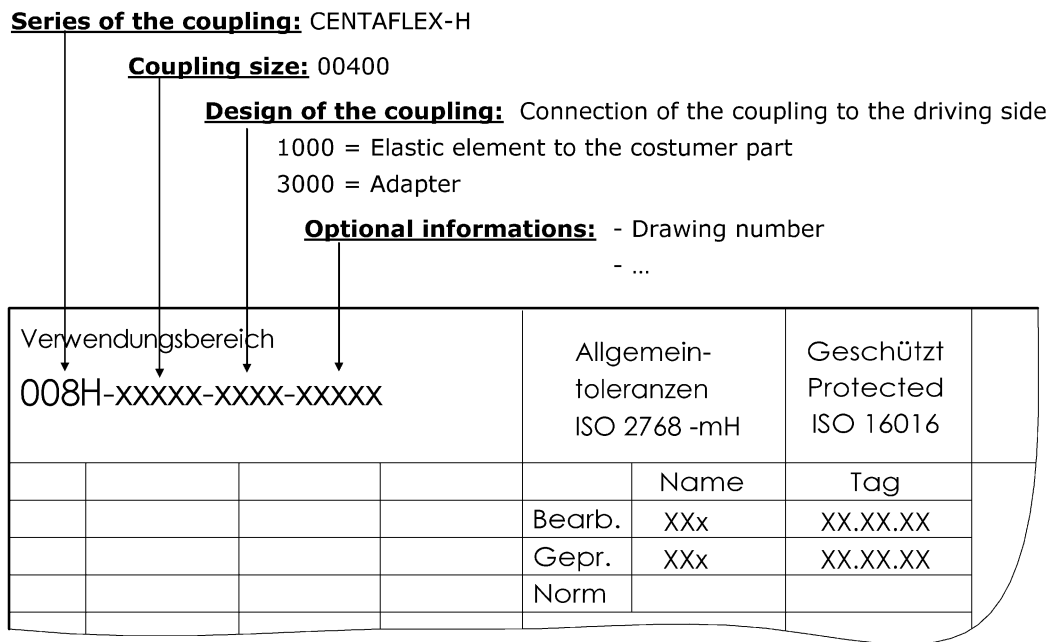

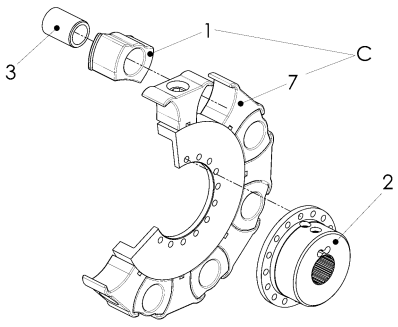
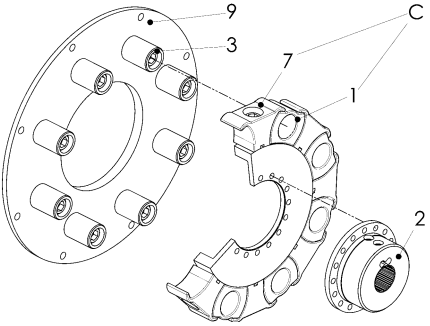

Fig. 5-1 Detail of the installation drawing title block

 <b>IMPORTANT</b>
<p>This assembly instruction describes the mounting of several design.          Mount the coupling as appropriate for the supplied design (see installation drawing).</p>

- Mount the coupling as appropriate for the supplied design. Take the supplied design as well as the built-in parts from the installation drawing. Scope of supply of the possible design, see following table.

Design	Scope of supply	Mounting see chapter
 <p><b>-1000</b></p>	<ul style="list-style-type: none"> <li>• Pre-mounted assembly (C)</li> <li>• Elastic element (1)</li> <li>• Hub (2)</li> <li>• Bush (3)</li> <li>• Adapter assembly (7)</li> </ul>	<p>5.4 – 5.9</p>
 <p><b>-3000</b></p>	<ul style="list-style-type: none"> <li>• Pre-mounted assembly (C)</li> <li>• Elastic element (1)</li> <li>• Hub (2)</li> <li>• Bush (3)</li> <li>• Hub (6)</li> <li>• Adapter assembly (7)</li> <li>• Adapter (9)</li> </ul>	<p>5.3 – 5.9</p>

*Table 5-1 Scope of supply of the design and chapters of mounting*



### 5.3 Mounting the adapter (9; design -3000)

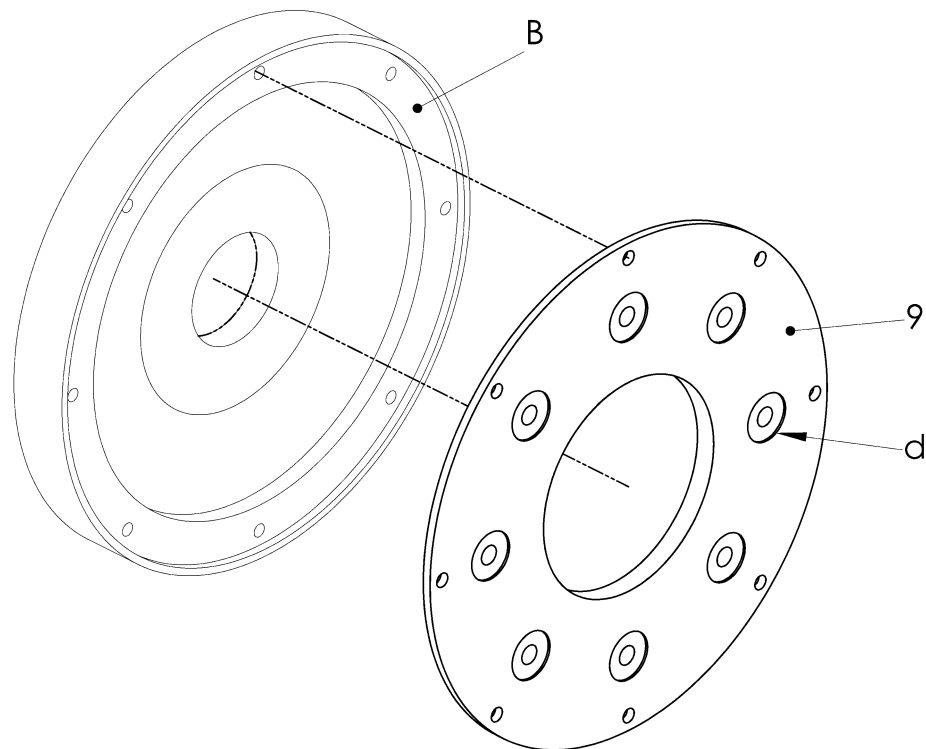

Fig. 5-2 Mounting the adapter (9; design -3000)

Item	Info	Designation	Remark
9		Adapter	
B		Flywheel	Customer part
	d	Centring	for bush

- Push the adapter (9) onto/into the centring of the flywheel (B). The centring for the bushes (d) must point towards the elastic elements.
- Screw the adapter (9) to the flywheel (B).

### 5.4 Preparing the pre-mounted assembly (C) for initial assembly

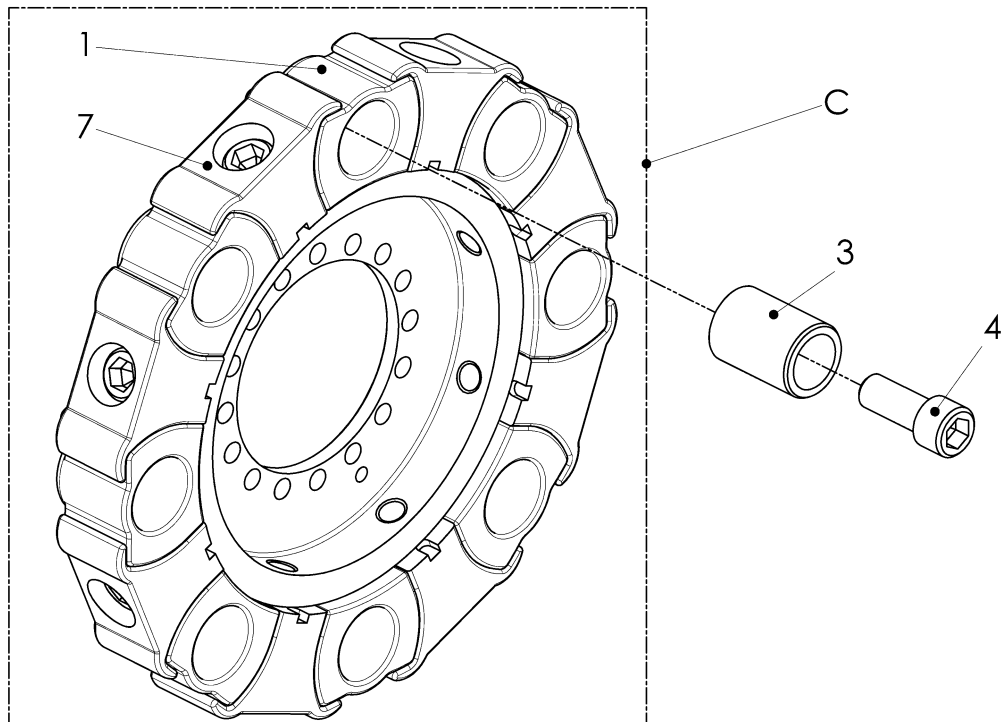

Fig. 5-3 Preparing the pre-mounted assembly (C) for initial assembly

Item	Info	Designation	Remark
1		Elastic element	
3		Bush	
4		Screw ISO4762-10.9 IP M..	If ordered
7		Adapter assembly	Pre-mounted by CENTA
C		Pre-mounted assembly	

** IMPORTANT**

The adapter assembly is delivered ready for installation. Do not dismantle any part.

- Push the bushes (3) and the screws (4; if ordered) out of the elastic element (1) and store temporarily.

### 5.5 Mounting the bushes (3)

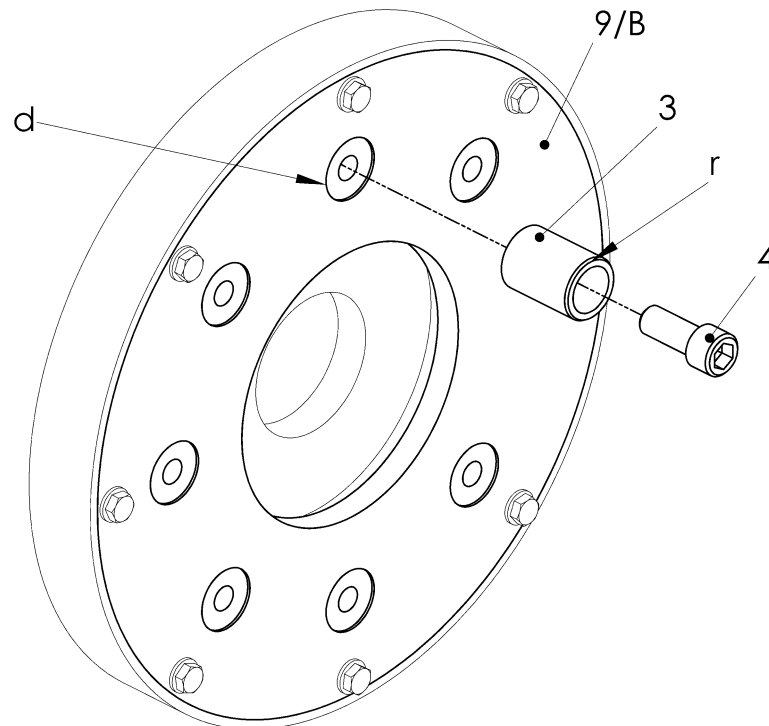

Fig. 5-4 Mounting the bushes (3)

Item	Info	Designation	Remark
3		Bush	
4		Screw ISO4762-10.9 IP M..	
9		Adapter	
B		Flywheel	Customer part
	d	Centring	for bush
	r	Radius	

- Push the bushes (3) into the centring for the bushes (d).
- Screw the bushes (3) to the adapter/flywheel (9/B; see installation drawing) using the screws (4). The radius (r) must point towards the elastic element (1). Screw preparation and tightening torque for the screws (4) see data sheet D013-019, chapter 9.2 .

## 5.6 Mounting the hub (2)

- Mount the hub (2) as appropriate for the supplied design (see installation drawing):
  - Mounting the hub (2) with cylindrical bore and keyway, see chapter 5.6.1 .
  - Mounting the hub (2) with CENTALOC clamping, see chapter 5.6.2 .

### 5.6.1 Mounting the hub (2) with cylindrical bore and keyway

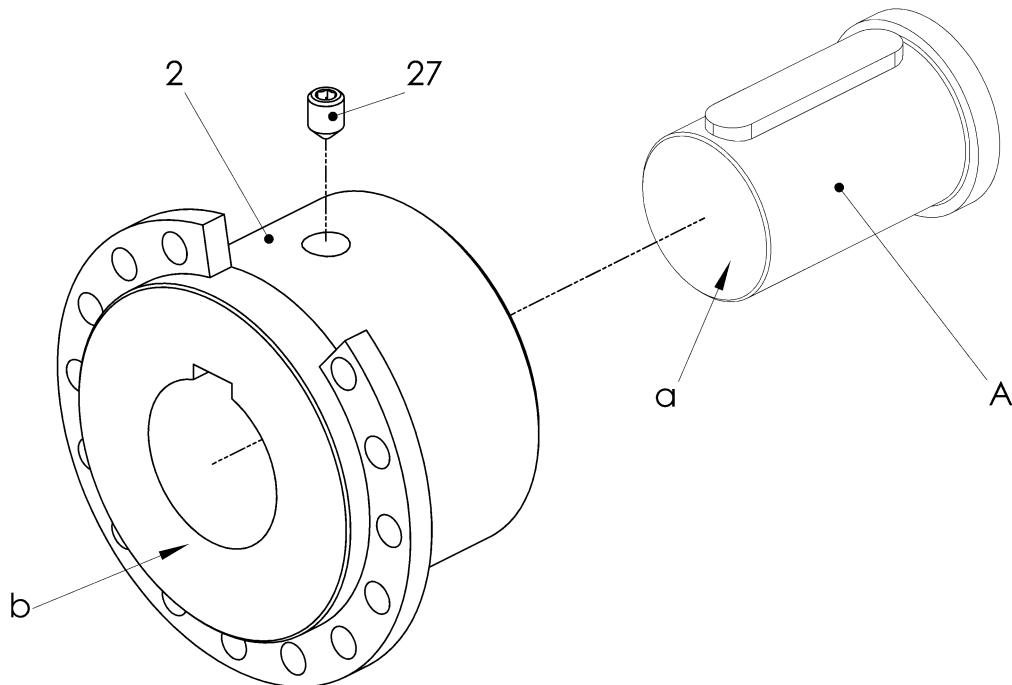



Fig. 5-5 Mounting the hub (2) with cylindrical bore and keyway

Item	Info	Designation	Remark
2		Hub	
27		Threaded pin	See installation drawing
A		Shaft	Customer part
	a	Face of shaft	
	b	Face of hub	

- Unscrew the threaded pin/-s (27; if existing) out of the hub (2) and store temporarily.

<b>CAUTION</b>	
	<p><b>Material damage can occur as a result of:</b></p> <ul style="list-style-type: none"> <li>▪ Incorrect heating of the hubs/flange hubs</li> </ul> <p>Heat the hubs/flange hubs steadily in an oil bath, a fan oven, on an electric hot plate, either inductive or with a flame (ring burner).</p>

<b>CAUTION</b>	
	<p><b>Injuries can occur as a result of:</b></p> <ul style="list-style-type: none"> <li>▪ Hot coupling components</li> </ul> <p>Use suitable protective gloves.</p>

- Heat the hub (2) to a temperature of 170° - 200°C.
- Push the hub (2) onto the shaft (A) with feather key.

 <b>IMPORTANT</b>
<p>The face of the shaft must not protrude to the face of the hub / flange hub. Otherwise the operation of the coupling is not guaranteed.</p>

- Secure the hub (2) with the threaded pin/-s (27; if necessary).  
 Threaded pin: size acc. the installation drawing  
 tightening torque see table below.

Threaded pin	M6	M8	M10	M12	M14	M16	M20
<b>Tightening torque [Nm]</b>	7	16	30	50	70	120	200

*Table 5-2 Tightening torques for threaded pins*

**5.6.2 Mounting the hub (2) with CENTALOC clamping**

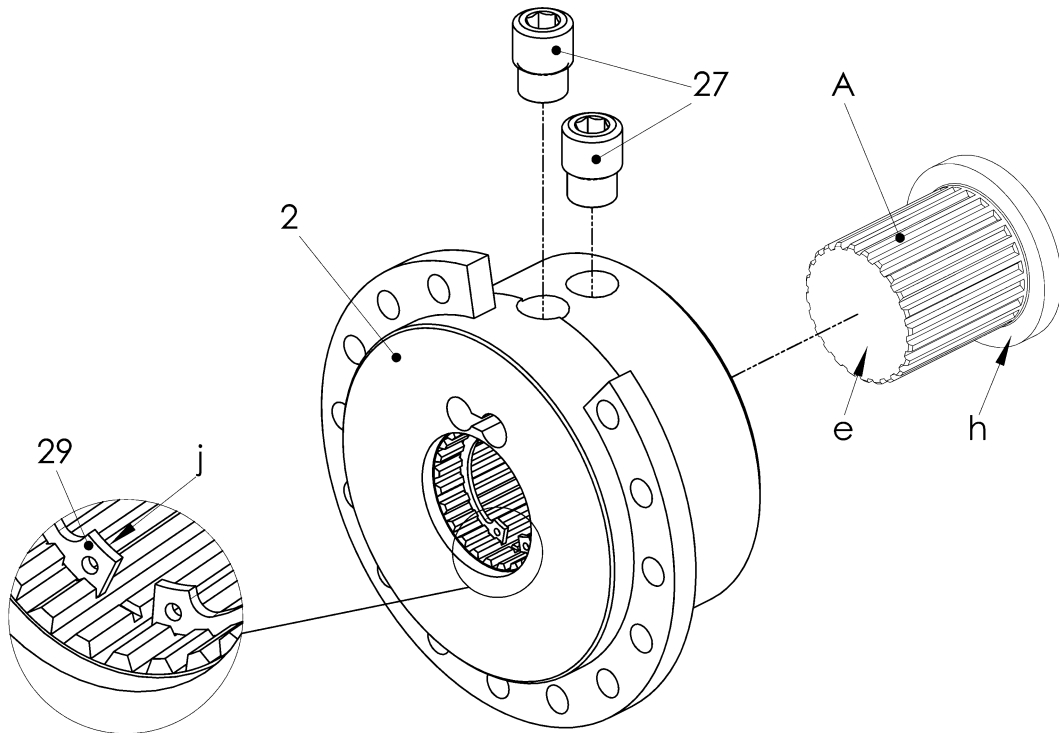

*Fig. 5-6 Mounting the hub (2) with CENTALOC clamping*

Item	Info	Designation	Remark
2		Hub	
27		Threaded pin	
29		Circlip DIN472	See installation drawing
A		Shaft	Customer part
	e	Shaft end	
	h	Shaft shoulder	
	j	Back side of circlip	

- Loosen the threaded pins (27).
- Push the hub (2) as appropriate for the supplied design **with/without** circlip (29; see installation drawing) onto the shaft (A):
  - **with** circlip (29):  
Push the hub (2) onto the shaft (A), until the shaft end (e) touches the back side of the circlip (j).

**IMPORTANT**

Ensure that the hub/flange hub is correctly positioned on the shaft (against shaft end).  
If necessary brace hub with washer against the shaft.

- **without** circlip (29):  
Push the hub (2) onto the shaft (A) against the shaft shoulder (h).

**IMPORTANT**

Ensure that the hub/flange hub is correctly positioned on the shaft (against shaft shoulder).  
If necessary brace hub with washer against the shaft.

- Secure the hub (2) with the threaded pins (27).  
Threaded pin: size acc. the installation drawing  
tightening torque see table 5-2, chapter 5.6.1 .

### 5.7 Mounting the pre-mounted assembly (C)

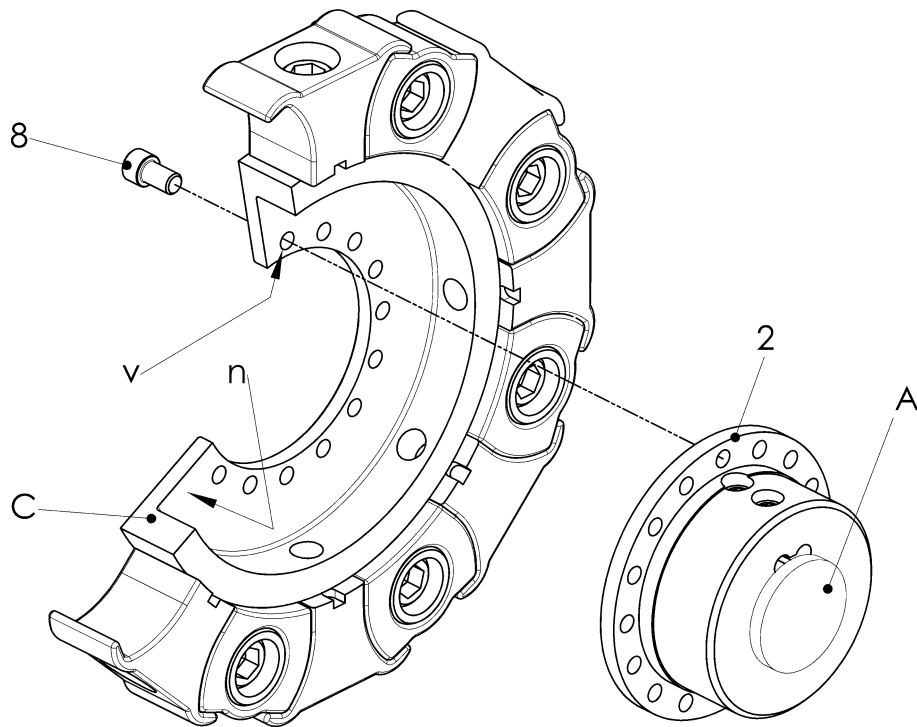

Fig. 5-7 Mounting the pre-mounted assembly (C) with drillings (v) to the hub (2)

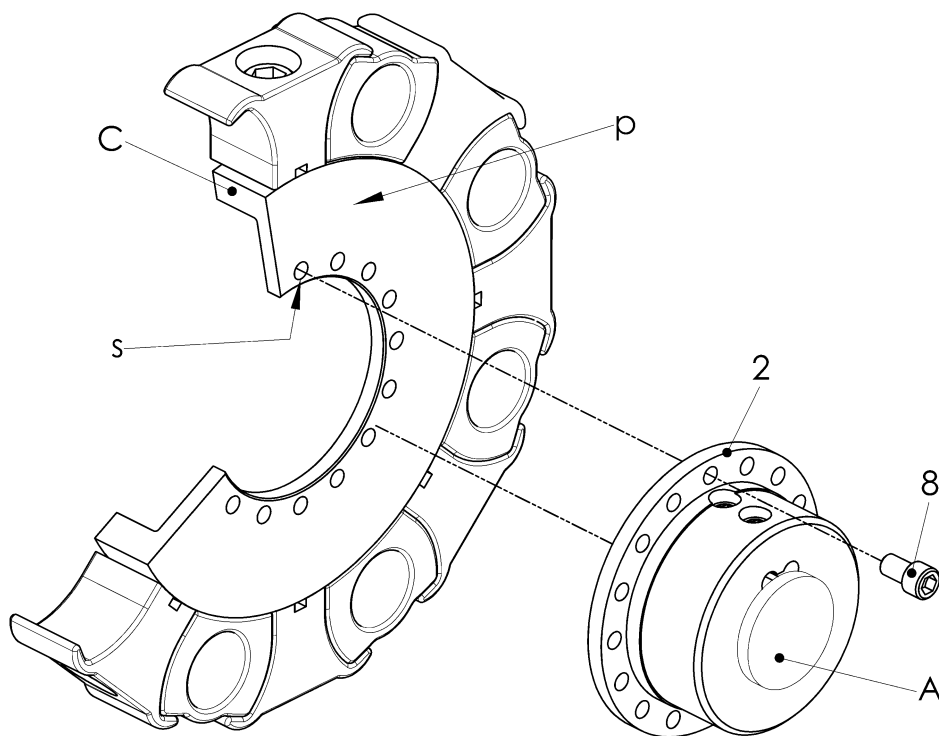

Fig. 5-8 Mounting the hub (2) to the pre-mounted assembly (C) with threads (s)



Item	Info	Designation	Remark
2		Hub	
8		Screw	
A		Shaft	Customer part
C		Pre-mounted assembly	
	n	Contact surface inside	
	p	Contact surface outside	
	s	Thread	See installation drawing
	v	Drilling	See installation drawing

**IMPORTANT**

Ensure during installation that the pre-mounted assembly is in the right position. The right position can be found in the installation drawing. Otherwise, correct assembling of the coupling is not guaranteed.

- Mount the pre-mounted assembly (C) with drillings/threads (s/v; see installation drawing):
- Pre-mounted assembly (C) **with drillings (v)**, see Fig. 5-7:
  - Push the pre-mounted assembly (C) onto the centring of the hub (2). The contact surface inside (n; see installation drawing) must point towards the hub (2).
  - Screw the pre-mounted assembly (C) to the hub (2) using the screws (8). Screw preparation and tightening torque for the screws (8) see data sheet D013-016, chapter 9.1 .
- Pre-mounted assembly (C) **with threads (s)**, see Fig. 5-8:
  - Push the pre-mounted assembly (C) onto the centring of the hub (2). The contact surface outside (p; see installation drawing) must point towards the hub (2).
  - Screw the hub (2) to the pre-mounted assembly (C) using the screws (8). Screw preparation and tightening torque for the screws (8) see data sheet D013-016, chapter 9.1 .

## 5.8 Connecting the driving and the driven units

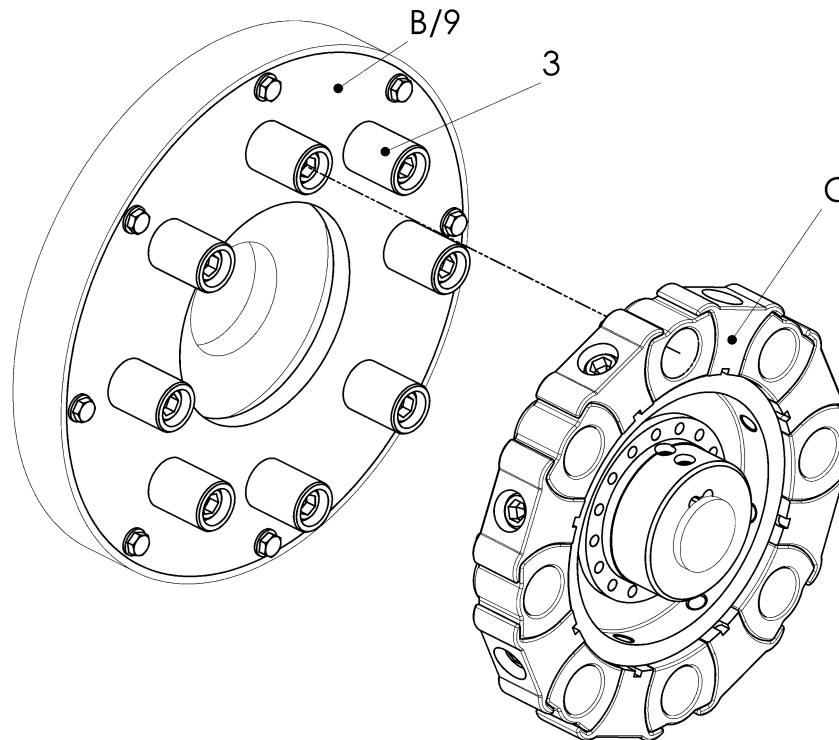

Fig. 5-9 Connecting the driving and the driven units

Item	Info	Designation	Remark
3		Bush	
9		Adapter	See installation drawing
B		Flywheel	Customer part
C		Pre-mounted assembly	

- Turn the driving unit with the bushes (3) towards the driven unit with the pre-mounted assembly (C) until it is possible to push the bushes (3) into the pre-mounted assembly (C).
- Push together the driving unit with the bushes (3) and the driven unit with the pre-mounted assembly (C).
- Screw the driving and the driven unit according to the manufacturer's instructions.

### CAUTION



**Motor damage can occur as a result of:**

- High axial forces at the axial bearings of the crank shaft
- Prior to commissioning the system, ensure that the crank shaft has axial play.

**5.9 After completed mounting****WARNING****Injury and material damage can occur as a result of:**

- Loose screw connections

Before commissioning, the tightening torque levels of all screws must be checked and corrected if necessary.

Before commencing long-term operation, the plant must successfully complete a test run.

## 6 Operation

### WARNING



**Injury and material damage can occur as a result of:**

- Worn coupling components

If the running noises change and/or vibrations occur turn the plant off immediately.

Determine the fault and its root cause, and remedy.  
The troubleshooting process is simplified by the table in the next chapter.  
On principle in case of a fault, an analysis of the entire plant should be performed.

### 6.1 Operating faults, root causes and remedy

In case of uncertainty or if you have questions, please contact our head office (address see chapter 1).

Faults	Possible root causes	Remedy
Running noises or vibrations in the plant	Tolerance error	<ol style="list-style-type: none"> <li>1. Switch off the plant</li> <li>2. Check the concentricity tolerances of the connections on the driving and driven units</li> <li>3. Trial run</li> </ol>
	Loose bolts	<ol style="list-style-type: none"> <li>1. Switch off the plant</li> <li>2. Check the tightening torques of the screws, correct if necessary</li> <li>3. Trial run</li> </ol>
Breakage of the elastic element/-s	Tolerance error	<ol style="list-style-type: none"> <li>1. Switch off the plant</li> <li>2. Replace the elastic element/-s</li> <li>3. Check the concentricity tolerances of the connections on the driving and driven units</li> <li>4. Trial run</li> </ol>
	Damage due to rotary oscillation: <ul style="list-style-type: none"> <li>• Cylinder failure</li> </ul>	<ol style="list-style-type: none"> <li>1. Switch off the plant</li> <li>2. Replace the elastic element/-s</li> <li>3. Trial run</li> </ol>
	Inadmissibly high torque	

Table 6-1 Troubleshooting table

## 7 Care and maintenance

### WARNING

**Injuries can occur as a result of:**

- Contact with rotating parts

Before starting work at the coupling, switch off the plant and secure against unintentional start-up.

The coupling requires low maintenance. We recommend a visual inspection at the regular scheduled maintenance intervals for the whole unit.

### 7.1 Work to be performed

#### 7.1.1 Cleaning the coupling

- Remove any loose dirt from the coupling.

#### 7.1.2 Visual inspection of the coupling

- Inspect the coupling for cracks, chips or missing parts.
- Replace faulty and missing parts.

#### 7.1.3 Visual inspection of the elastic element/-s

**IMPORTANT**

Exchange the elastic element/-s in the event of damage.

- Check the elastic element/-s for cracks.

#### 7.1.4 Inspection of the screw connections

- Check the tightening torque levels of all screws and if necessary, correct.

### 7.2 Replacing defective parts

- Remove the coupling as described in chapter 8.
- Replace wearing parts.
- Mount the coupling as described in chapter 5.

## 8 Dismantling

### 8.1 General dismantling instructions

Any work method which impairs the safety of the coupling is prohibited.  
The user undertakes to notify the manufacturer immediately of any changes occurring at the coupling which could impair safety (address see chapter 1).



#### IMPORTANT

- This assembly instruction describes the dismantling of several design. Dismantle the coupling as appropriate for the supplied design (see installation drawing).
- The coupling is dismantled in reverse order to the assembly process. Please refer to the illustrations in chapter 5.
- Use suitable lifting devices for dismantling.

#### WARNING

**Injuries can occur as a result of:**

- Contact with rotating parts

Before starting work at the coupling, switch off the plant and secure against unintentional start-up.

#### WARNING

**Injury and material damage can occur as a result of:**

- Dismantling of the coupling in the wrong sequence
- Only ever dismantle the coupling in the described sequence.

#### WARNING

**Injury and material damage can occur as a result of:**

- Falling coupling components

Secure coupling components against falling to the floor.

#### CAUTION

**Material damage to coupling components can occur as a result of:**

- Contact with sharp-edged objects

Protect coupling components for transportation.

Only hoist coupling components with nylon belts or ropes.

Always cushion parts when supporting them from below.

## 8.2 Separating the driving and the driven units

See Fig. 5-9:

- Loosen and remove the screws of the connection of the driving and driven units.
- Pull the driving and driven units apart.

## 8.3 Dismantling the elastic elements

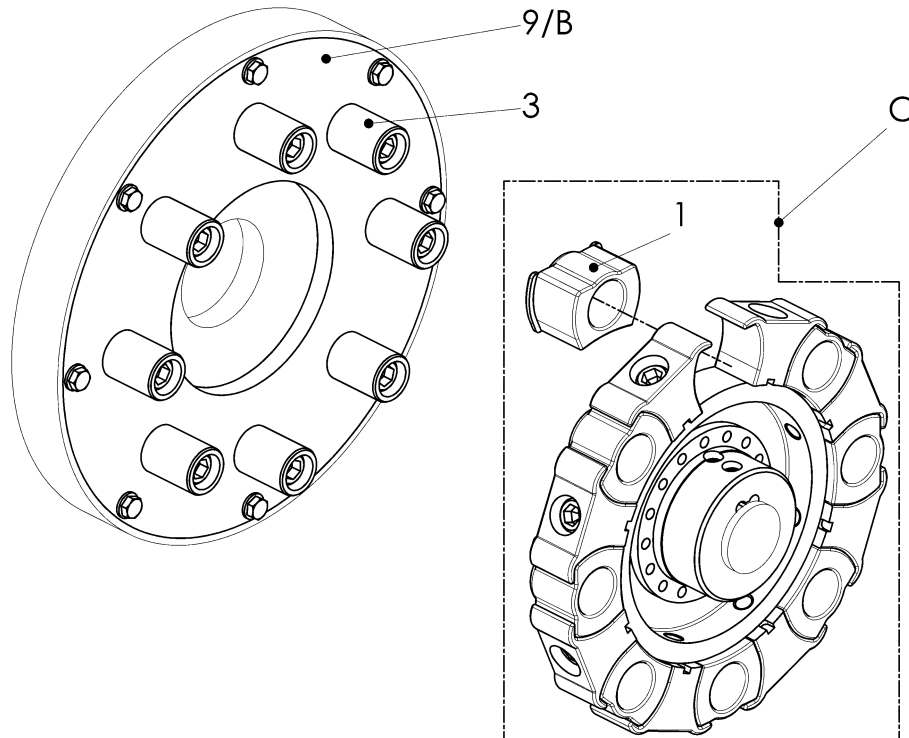

Fig. 8-1 Dismantling the elastic elements

Item	Info	Designation	Remark
1		Elastic element	
3		Bush	
9		Adapter	
B		Flywheel	Customer part
C		Pre-mounted assembly	

- Remove the elastic elements (1) out of the pre-mounted assembly (C).

## 8.4 Dismantling the pre-mounted assembly (C) from the hub (2)

See Fig. 5-7 or 5-8:

- Loosen and remove the screws (8) of the connection pre-mounted assembly (C) and hub (2).
- Pull the pre-mounted assembly (C) off the centring of the hub (2) and remove.

## 8.5 Dismantling the hub (2; if necessary)

- Dismantle the hub (2) as appropriate for the supplied design (see installation drawing):
  - Dismantling the hub (2) with cylindrical bore and keyway, see chapter 8.5.1 .
  - Dismantling the hub (2) with CENTALOC clamping, see chapter 8.5.2 .

### 8.5.1 Dismantling the hub (2) with cylindrical bore and keyway

See Fig. 5-5:

- Loosen the threaded pin/-s (27; if existing) and remove off the hub (2).
- Remove the hub (2) from the shaft (A).

### 8.5.2 Dismantling the hub (2) with CENTALOC clamping

See Fig. 5-6:

- Loosen the threaded pins (27).
- Remove the hub (2) from the shaft (A).

## 8.6 Dismantling the bushes (3; if necessary)

See Fig. 5-4:

- Loosen the screws (4) and remove with the bushes (3).

## 8.7 Dismantling the adapter (9; design -3000; if necessary)

See Fig. 5-2:

- Loosen and remove the screws of the connection adapter (9) and flywheel (B).
- Pull the adapter (9) out of/off the centring of the flywheel (B) and remove.

## 8.8 Reassembling the coupling

- Reassemble the coupling as described in chapter 5.





## 9 Annex

### 9.1 CENTA data sheet D013-016 (unlubricated screw connections)

**Validity:**

For all non-dynamically stressed screw connections with **not lubricated** shank bolts in accordance with ISO 4014, ISO 4017 and ISO 4762 (DIN 912) with metric standard thread in accordance with DIN ISO 262, unless other specifications are given on CENTA documents.

**Preparation of parts that are to be screwed together:**

The joining areas must be free of dirt, preservatives and lubricants.

**Preparation of screws that ARE NOT secured with liquid screw locking medium:**

Use screws as delivered.

**Preparation of screws that ARE secured with liquid screw locking medium:**

Remove all grease from the thread.

**Screw tightening method:**

Screw in (by hand with torque wrench).

d	Thread size			d	Thread size		
	Strength class	Tightening torques			Strength class	Tightening torques	
		[Nm] ±5%	[in lbs] ±5%			[Nm] ±5%	[in lbs] ±5%
M6	8.8	10	90	M22	8.8	470	4160
	10.9	14	125		10.9	670	5930
	12.9	17	150		12.9	780	6900
M8	8.8	23	205	M24	8.8	600	5310
	10.9	34	300		10.9	850	7520
	12.9	40	350		12.9	1000	8850
M10	8.8	46	410	M27	8.8	750	6640
	10.9	68	600		10.9	1070	9470
	12.9	79	700		12.9	1250	11060
M12	8.8	79	700	M30	8.8	1000	8850
	10.9	117	1050		10.9	1450	12830
	12.9	135	1200		12.9	1700	15050
M14	8.8	125	1100	M33	8.8	1400	12400
	10.9	185	1650		10.9	1950	17250
	12.9	215	1900		12.9	2300	20350
M16	8.8	195	1725	M36	8.8	1750	15500
	10.9	280	2500		10.9	2500	22150
	12.9	330	2900		12.9	3000	26550
M18	8.8	245	2200	M39	8.8	2300	20350
	10.9	350	3100		10.9	3300	29200
	12.9	410	3600		12.9	3800	33650
M20	8.8	350	3100				
	10.9	490	4350				
	12.9	580	5150				



## 9.2 CENTA data sheet D13-019 (IP-screw connections)

### Validity:

For all non-dynamically stressed screw connections with **IP\*-screws** in accordance with ISO 4014, ISO 4017 and ISO 4762 (DIN 912) with metric standard thread in accordance with DIN ISO 262 and **IP\*-socket bolts** with metric standard thread in accordance with DIN ISO 262, unless other specifications are given on CENTA documents.

\* The threads are coated with microencapsulated adhesive INBUS-PLUS (**IP**) which serves as a screw locking medium.

### Preparation of parts that are to be screwed together:

The joining areas must be free of dirt, preservatives and lubricants.

### Preparation of IP-screws:

Give the IP-screws extra lubrication with grease under the screw head.

### Screw tightening method:

Screw in (by hand with torque wrench).

### Curing time for the microencapsulated adhesive:

To ensure optimum screw locking, after tightening the curing time for the microencapsulated adhesive must be observed:

- Appr. 4-5 hours at room temperature (20°C)
- Higher temperatures will accelerate the curing time (e.g. 15 minutes at 70°C created by a hot air blower)

After 24 hours, the adhesive is completely cured.

CENTAFLEX			Thread size d	Strength class	Tightening torques	
A Size	H Size	X Size			[Nm] ±5%	[in lbs] ±5%
1	--	1	M6	8.8	10	90
2/4	--	2/4	M8		25	220
8/12	8	8	M10		50	440
16/22	16	16	M12		85	750
25/28	25	25	M14		140	1250
30/50/80	30/50/90	30/90	M16		220	1950
--	110	--	M18	10.9	300	2650
90/140/ 200/250	140/160/ 250/400	--	M20		500	4450
400	--	--	M20		610	5400
	--	--	M24		1050	9300
600	--	--	M24		1050	9300
	--	--	M27		1550	13700
800	--	--	M22	820	7250	



**9.3 CENTA data sheet D008-902  
Declaration of incorporation according to the EC Machinery  
Directive 2006/42/EC, Appendix II B**

Manufacturer:

**CENTA Antriebe  
Kirschey GmbH**  
Bergische Strasse 7  
42781 Haan / GERMANY

Contact:

Phone +49-2129-912-0  
Fax +49-2129-2790  
centa@centa.de  
www.centa.info

We herewith declare that the **incomplete** machine

Product: Torsionally stiff coupling CENTAFLEX-H

Model / series code: CF-H / 008H

Installation size: 8...400

Design: all

Serial number: according to shipping documents, if applicable

- provided this is possible as far as the scope of supply is concerned - complies with the following basic requirements of the **Machinery Directive 2006/42/EC** Appendix I, subchapters 1.1.2, 1.1.3, 1.1.5, 1.3.2, 1.3.3, 1.3.4 and 1.5.4.

In addition, we declare that the special technical documents for this incomplete machine were compiled according to Appendix VII Part B and undertake to forward these to the market monitoring authorities by request via our "Documentation Department".

Commissioning of the incomplete machine is interdicted until the incomplete machine has been incorporated in a machine and the latter complies with the provisions of the EC Machinery Directive and the EC Declaration of Conformity according to Appendix II A is on hand.

The declaration is invalidated by every modification to the delivered parts.

Authorised representative for the compilation of the relevant technical documents:

*i.A. G. Anderseck*

by order of Gunnar Anderseck  
(Authorised Person Documentation)

Declaration of incorporation was issued:

*i.v. J. Exner*

by proxy Dipl.-Ing. Jochen Exner  
(Design Management)

Haan, 11.12.2009